

SURFACE WATER PRODUCTION

CONTINUING EDUCATION PROFESSIONAL DEVELOPMENT COURSE

16 PDHs, 16 Training Hours or 1.6 CEUs upon completion



Printing and Saving Instructions

The best thing to do is to download this pdf document to your computer desktop and open it with Adobe Acrobat reader.

Abode Acrobat reader is a free computer software program and you can find it at Abode Acrobat's website.

You can complete the course by viewing the course materials on your computer or you can print it out. We give you permission to print this document.

Printing Instructions: If you are going to print this document, this document is designed to be printed double-sided or duplexed but can be single-sided.

This course booklet does not have the assignment. Please visit our website and download the assignment also.

Internet Link to Assignment...

<http://www.abctlc.com/PDF/SurfaceWaterProductionASS.pdf>

State Approval Listing Link, check to see if your State accepts or has pre-approved this course. Not all States are listed. Not all courses are listed. If the course is not accepted for CEU credit, we will give you the course free if you ask your State to accept it for credit.

Professional Engineers: Most states will accept our courses for credit but we do not officially list the States or Agencies acceptance or approvals.

State Approval Listing URL...

<http://www.tlch2o.com/PDF/CEU%20State%20Approvals.pdf>

You can obtain a printed version from TLC for an additional \$79.95 plus shipping charges.



Copyright Notice

©2005 Technical Learning College (TLC). No part of this work may be reproduced or distributed in any form or by any means without TLC's prior written approval. Permission has been sought for all images and text where we believe copyright exists and where the copyright holder is traceable and contactable. All material not credited or acknowledged is the copyright of TLC. The information in this manual is intended for educational purposes only. Most unaccredited photographs have been taken by TLC instructors or TLC students. We would be pleased to hear from any copyright holder and will make good on your work if any unintentional copyright infringements were made upon these issues being brought to our attention.

Every possible effort is made to ensure all information provided in this course is accurate. All written, graphic, photographic or other material is provided for information only. Therefore, TLC accepts no responsibility or liability whatsoever for the application or misuse of any information included herein. Requests for permission to make copies should be made to the following address:

TLC
PO Box 420
Payson, AZ 85547-0420

Information in this document is subject to change without notice. TLC is not liable for errors or omissions appearing in this document.

Technical Learning College's Scope and Function

Technical Learning College (TLC) offers affordable continuing education for today's working professionals who need to maintain licenses or certifications. TLC holds approximately eighty different governmental approvals for granting of continuing education credit.

TLC's delivery method of continuing education can include traditional types of classroom lectures and distance-based courses or independent study. Most TLC's distance based or independent study courses are offered in a print based format and you are welcome to examine this material on your computer with no obligation. Our courses are designed to be flexible and for you do finish the material on your leisure. Students can also receive course materials through the mail. The CEU course or e-manual will contain all your lessons, activities and assignments. Most CEU courses allow students to submit lessons using e-mail or fax; however some courses require students to submit lessons by postal mail. (See the course description for more information.) Students have direct contact with their instructor—primarily by e-mail. TLC's CEU courses may use such technologies as the World Wide Web, e-mail, CD-ROMs, videotapes and hard copies. (See the course description.) Make sure you have access to the necessary equipment before enrolling, i.e., printer, Microsoft Word and/or Adobe Acrobat Reader. Some courses may require proctored exams depending upon your state requirements.

Flexible Learning

At TLC, there are no scheduled online sessions you need contend with, nor are you required to participate in learning teams or groups designed for the "typical" younger campus based student. You will work at your own pace, completing assignments in time frames that work best for you. TLC's method of flexible individualized instruction is designed to provide each student the guidance and support needed for successful course completion.

We will beat any other training competitor's price for the same CEU material or classroom training. Student satisfaction is guaranteed.

Course Structure

TLC's online courses combine the best of online delivery and traditional university textbooks. Online you will find the course syllabus, course content, assignments, and online open book exams. This student friendly course design allows you the most flexibility in choosing when and where you will study.

Classroom of One

TLC Online offers you the best of both worlds. You learn on your own terms, on your own time, but you are never on your own. Once enrolled, you will be assigned a personal Student Service Representative who works with you on an individualized basis throughout your program of study. Course specific faculty members are assigned at the beginning of each course providing the academic support you need to successfully complete each course.

Satisfaction Guaranteed

Our Iron-Clad, Risk-Free Guarantee ensures you will be another satisfied TLC student.

We have many years of experience, dealing with thousands of students. We assure you, our customer satisfaction is second to none. This is one reason we have taught more than 20,000 students.

Our administrative staff is trained to provide the best customer service in town. Part of that training is knowing how to solve most problems on the spot with an exchange or refund.

TLC Continuing Education Course Material Development

Technical Learning College's (TLC's) continuing education course material development was based upon several factors; extensive academic research, advice from subject matter experts, data analysis, task analysis and training needs assessment process information gathered from other states.



Rush Grading Service

If you need this assignment graded and the results mailed to you within a 48-hour period, prepare to pay an additional rush service handling fee of \$50.00. This fee may not cover postage costs. If you need this service, simply write RUSH on the top of your Registration Form. We will place you in the front of the grading and processing line.

For security purposes, please fax or e-mail a copy of your driver's license and always call us to confirm we've received your assignment and to confirm your identity.

Thank you...

Please fax or e-mail the answer key to TLC
Western Campus Fax (928) 272-0747 Back-up Fax (928) 468-0675.

Surface Water Production CEU Training Course Description

This CEU training course will cover various and commonly found in surface water treatment processes, methods and chemistry fundamentals starting at the source of water and ending with disinfection to delivery through distribution. We as Operators need to make sure that our finished water meets federal compliance and minimum standards.

Water Distribution, Well Drillers, Pump Installers, Water Treatment Operators, Water Treatment Specialists and Customer Service Personnel are welcomed to take this course. The target audience for this course is the person interested in working in a water treatment or distribution facility and/or wishing to maintain CEUs for a certification license or to learn how to do the job safely and effectively and/or to meet education needs for promotion.

Task Analysis and Training Needs Assessments have been conducted to determine or set Needs-To-Know for this CEU course. The following is a listing of some of those who have conducted extensive valid studies from which TLC has based this program upon: the Environmental Protection Agency (EPA), the Arizona Department of Environmental Quality (ADEQ), the Texas Commission of Environmental Quality (TCEQ) and the American Boards of Certification (ABC).



Final Examination for Credit

Opportunity to pass the final comprehensive examination is limited to three attempts per course enrollment.

Course Procedures for Registration and Support

All of TLC's correspondence courses have complete registration and support service offered. Delivery of service will include, e-mail, web site, telephone, fax and mail support. TLC will attempt immediate and prompt service.

When a student registers for a distance or correspondence course, he or she is assigned a start date and an end date. It is the student's responsibility to note dates for assignments and keep up with the course work. If a student falls behind, he/she must contact TLC and request an end date extension in order to complete the course. It is the prerogative of TLC to decide whether to grant the request. All students will be tracked by a unique assigned number.

Instructions for Written Assignments

The Surface Water Production CEU training course uses a multiple-choice and fill-in-the-blank answer key. You can find the Microsoft Word version on the Assignment page. We would prefer the answers are typed and faxed or e-mailed to info@tlch2o.com. If you are unable to do so, please write inside the assignment booklet, make a copy for yourself and mail us the completed manual. Please feel free to call us if you need assistance.

Other Student Information

Feedback Mechanism (Examination procedures)

Each student will receive a feedback form as part of their study packet. You will be able to find this form in the rear of the course or lesson. By completing this form, you can help us improve our course and serve your need better in the future.

Security and Integrity

All students are required to do their own work. All lesson sheets and final exams are not returned to the student to discourage sharing of answers. Any fraud or deceit will result in the student forfeiting all fees, and the appropriate agency will be notified.

Grading Criteria

TLC offers the student either pass/fail or a standard letter grading assignment if we are notified by the student. If we are not notified, you will only receive a certificate for passing the test.

Recordkeeping and Reporting Practices

TLC will keep all student records for a minimum of seven years. It is the student's responsibility to give the completion certificate to the appropriate agencies. TLC will not release any records to any party, except to the student self.

ADA Compliance

TLC will make reasonable accommodations for persons with documented disabilities. Students should notify TLC and their instructors of any special needs. Course content may vary from this outline to meet the needs of this particular group.

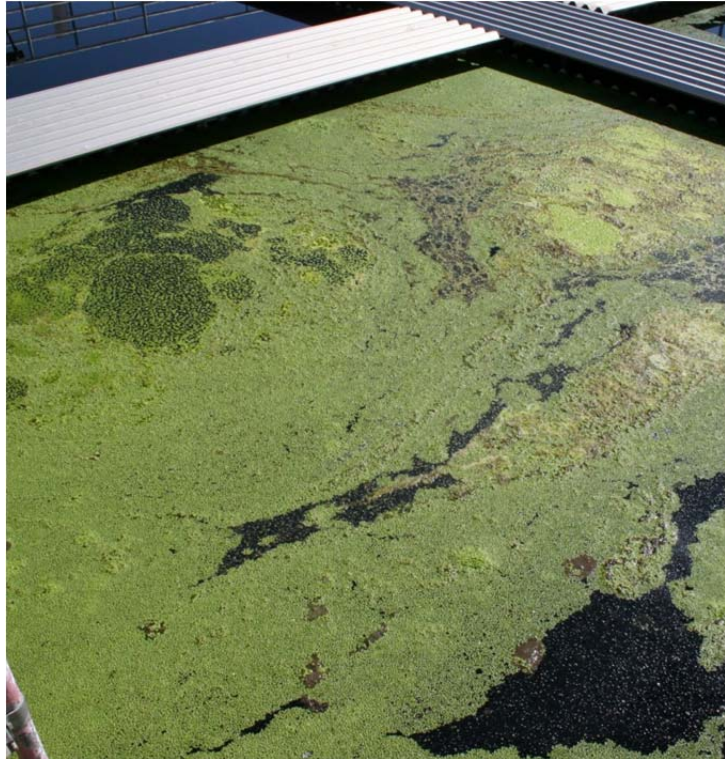

Mission Statement

Our only product is educational service. Our goal is to provide you with the best education service possible. TLC attempts to make your learning experience an enjoyable educational opportunity.



Tools of the Trade. Bac-T sample bottle and notice the Quanti-trays in background. The yellow color indicates the water sample is positive for coliform bacteria. The positive sample will fluoresce under a black light; this will indicate the sample is positive for fecal or E. Coli bacteria. Check out the water monitoring section for more information on bacteria and different water sampling information.



TABLE OF CONTENTS

Homeland Security	Chapter 1
Threat Conditions	19
Bio-Chemical Terror	27
SDWA	Chapter 2
SDWA Terms	33
Microbes	38
SDWA Elements	39
Water Quality Information	47
New EPA Rules	49
Primary Drinking Water Requirements	53
Secondary Drinking Water Regulations	59
Water Treatment	Chapter 3
Water Treatment	61
Preliminary Treatment	63
Pre-Sedimentation	64
Conventional Treatment	69
Rapid Sand	71
Filter Backwash	79
Hard Water	113
Membrane Filtration	119
Reverse Osmosis	123
GAC/PAC	127
Ozone	129
Water Disinfectants	134
Water Production	Chapter 4
Water Sources	147
Contaminated Wells	149
Groundwater Section	153
Surging or Backwashing	161
Pumping Rates	163
Water Quality	Chapter 5
Key Words	173
Types of Algae	185
Jar Test	187
Measure Turbidity	189
KMnO ₄ Jar Test	193
Alkalinity Test	197
Oxygen	202
TDS	203
Turbidity	204

TOC	205
Arsenic Treatment	211
Periodic Table	219
pH Scale	221
Bacteriological Section	225
Positive Samples	228
HPC	230
Total Coliforms	232

Chlorine	Chapter 6
Chlorine Gas	263
Cl ₂ Chemistry	271
CT Value	273
DPD Method	274
DDBP	275
Chlorinator Parts	278
Equipment Requirement	279
Alternative Disinfectants	285
Amperometric Titration	286
Cl ₂ Dioxide	288
Hypochlorite Solutions	289
Fluoride	295

Glossary	298
Common Chemicals	337
Microorganisms Appendix	339
Math Conversions	393
References	397

Contributing Editors

Joseph Camerata has a BS in Management with honors (magna cum laude). He retired as a Chemist in 2006 having worked in the field of chemical, environmental, and industrial hygiene sampling and analysis for 40 years. He has been a professional presenter at an EPA analytical conference at the Biosphere in Arizona and a presenter at an AWWA conference in Mesa, Arizona. He also taught safety classes at the Honeywell and City of Phoenix, and is a motivational/inspirational speaker nationally and internationally.

Eric Pearce S.M.E., chemistry and biological review.

Pete Greer S.M.E., retired biology instructor.

Jack White, Environmental, Health, Safety Expert, City of Phoenix. Art Credits.

Common Water Treatment Acronyms

AA Activated alumina
AC Activated carbon
ASR Annual Status Report
As(III) Trivalent arsenic, common inorganic form in water is arsenite, H_3AsO_3
As(V) Pentavalent arsenic, common inorganic form in water is arsenate, H_2AsO_4
BDAT best demonstrated available technology
BTEX Benzene, toluene, ethylbenzene, and xylene
CCA Chromated copper arsenate
CERCLA Comprehensive Environmental Response, Compensation, and Liability Act
CERCLIS 3 CERCLA Information System
CLU-IN EPA's CLeanUp INformation system
CWS Community Water System
cy Cubic yard
DDT Dichloro-diphenyl-trichloroethane
DI De-ionized
DOC Dissolved organic carbon
DoD Department of Defense
DOE Department of Energy
EDTA Ethylenediaminetetraacetic acid
EPA U.S. Environmental Protection Agency
EPT Extraction Procedure Toxicity Test
FRTR Federal Remediation Technologies Roundtable
ft feet
GJO DOE's Grand Junction Office
gpd gallons per day
gpm gallons per minute
HTMR High temperature metals recovery
MCL Maximum Contaminant Level (enforceable drinking water standard)
MF Microfiltration
MHO Metallurgie-Hoboken-Overpelt
mgd million gallons per day
mg/kg milligrams per kilogram
mg/L milligrams per Liter
NF Nanofiltration
NPL National Priorities List
OCLC Online Computer Library Center
ORD EPA Office of Research and Development
OU Operable Unit
PAH Polycyclic aromatic hydrocarbons
PCB Polychlorinated biphenyls
POTW Publicly owned treatment works
PRB Permeable reactive barrier
RCRA Resource Conservation and Recovery Act
Redox Reduction/oxidation
RO Reverse osmosis
ROD Record of Decision
SDWA Safe Drinking Water Act
SMZ surfactant modified zeolite

SNAP Superfund NPL Assessment Program
S/S Solidification/Stabilization
SVOC Semi-volatile organic compounds
TCLP Toxicity Characteristic Leaching
Procedure
TNT 2,3,6-trinitrotoluene
TWA Total Waste Analysis
UF Ultrafiltration
VOC Volatile organic compounds
WET Waste Extraction Test
ZVI Zero valent iron



The inspector is using a pH meter to check a grab sample.

Purpose

The Nation requires a Homeland Security Advisory System to provide a comprehensive and effective means to disseminate information regarding the risk of terrorist acts to Federal, State, and local authorities and to the American people.

Such a system would provide warnings in the form of a set of graduated "**Threat Conditions**" that would increase as the risk of the threat increases. At each Threat Condition, Federal departments and agencies would implement a corresponding set of "**Protective Measures**" to further reduce vulnerability or increase response capability during a period of heightened alert.

This system is intended to create a common vocabulary, context, and structure for an ongoing national discussion about the nature of the threats that confront the homeland and the appropriate measures that should be taken in response. It seeks to inform and facilitate decisions appropriate to different levels of government and to private citizens at home and at work.

Homeland Security Advisory System *Old System out dated 4/20/2011*

The Homeland Security Advisory System shall be binding on the executive branch and suggested, although voluntary, to other levels of government and the private sector. There are five Threat Conditions, each identified by a description and corresponding color. From lowest to highest, the levels and colors are:

Low = Green;
Guarded = Blue;
Elevated = Yellow;
High = Orange;
Severe = Red.

The higher the Threat Condition, the greater the risk of a terrorist attack. Risk includes both the probability of an attack occurring and its potential gravity. Threat Conditions shall be assigned by the Attorney General in consultation with the Assistant to the President for Homeland Security.

Except in exigent circumstances, the Attorney General shall seek the views of the appropriate Homeland Security Principals or their subordinates, and other parties as appropriate, on the Threat Condition to be assigned.

Threat Conditions may be assigned for the entire Nation, or they may be set for a particular geographic area or industrial sector. Assigned Threat Conditions shall be reviewed at regular intervals to determine whether adjustments are warranted.

For facilities, personnel, and operations inside the territorial United States, all Federal departments, agencies, and offices other than military facilities shall conform their existing threat advisory systems to this system and henceforth administer their systems consistent with the determination of the Attorney General with regard to the Threat Condition in effect.

Over the last year, you probably have grown tired or used to these warnings.

Threat Condition

The assignment of a Threat Condition shall prompt the implementation of an appropriate set of Protective Measures. Protective Measures are the specific steps an organization shall take to reduce its vulnerability or increase its ability to respond during a period of heightened alert. The authority to craft and implement Protective Measures rests with the Federal departments and agencies. It is recognized that departments and agencies may have several preplanned sets of responses to a particular Threat Condition to facilitate a rapid, appropriate, and tailored response.

Department and agency heads are responsible for developing their own Protective Measures and other antiterrorism or self-protection and continuity plans, and resourcing, rehearsing, documenting, and maintaining these plans. Likewise, they retain the authority to respond, as necessary, to risks, threats, incidents, or events at facilities within the specific jurisdiction of their department or agency, and, as authorized by law, to direct agencies and industries to implement their own Protective Measures.

Protective Measures

They shall continue to be responsible for taking all appropriate proactive steps to reduce the vulnerability of their personnel and facilities to terrorist attack. Federal department and agency heads shall submit an annual written report to the President, through the Assistant to the President for Homeland Security, describing the steps they have taken to develop and implement appropriate Protective Measures for each Threat Condition. Governors, mayors, and the leaders of other organizations are encouraged to conduct a similar review of their organizations' Protective Measures.

The decision whether to publicly announce Threat Conditions shall be made on a case-by-case basis by the Attorney General in consultation with the Assistant to the President for Homeland Security. Every effort shall be made to share as much information regarding the threat as possible, consistent with the safety of the Nation. The Attorney General shall ensure, consistent with the safety of the Nation, that State and local government officials and law enforcement authorities are provided the most relevant and timely information.

The Attorney General shall be responsible for identifying any other information developed in the threat assessment process that would be useful to State and local officials and others and conveying it to them as permitted consistent with the constraints of classification. The Attorney General shall establish a process and a system for conveying relevant information to Federal, State, and local government officials, law enforcement authorities, and the private sector expeditiously.

The Director of Central Intelligence and the Attorney General shall ensure that a continuous and timely flow of integrated threat assessments and reports is provided to the President, the Vice President, Assistant to the President and Chief of Staff, the Assistant to the President for Homeland Security, and the Assistant to the President for National Security Affairs. Whenever possible and practicable, these integrated threat assessments and reports shall be reviewed and commented upon by the wider interagency community.

A decision on which Threat Condition to assign shall integrate a variety of considerations. This integration will rely on qualitative assessment, not quantitative calculation.

NTAS GUIDE

National Terrorism Advisory System Public Guide

April 2011

The National Terrorism Advisory System

The National Terrorism Advisory System, or NTAS, replaces the color-coded Homeland Security Advisory System (HSAS). This new system will more effectively communicate information about terrorist threats by providing timely, detailed information to the public, government agencies, first responders, airports and other transportation hubs, and the private sector.

It recognizes that Americans all share responsibility for the nation's security, and should always be aware of the heightened risk of terrorist attack in the United States and what they should do.

"The terrorist threat facing our country has evolved significantly over the past ten years, and in today's environment – more than ever – we know that the best security strategy is one that counts on the American public as a key partner in securing our country," said Secretary Napolitano. "The National Terrorism Advisory System, which was developed in close collaboration with our federal, state, local, tribal and private sector partners, will provide the American public with information about credible threats so that they can better protect themselves, their families, and their communities."

Under NTAS, DHS will coordinate with other federal entities to issue detailed alerts to the public when the federal government receives information about a credible terrorist threat.

NTAS alerts provide a concise summary of the potential threat including geographic region, mode of transportation, or critical infrastructure potentially affected by the threat, actions being taken to ensure public safety, as well as recommended steps that individuals, communities, business and governments can take to help prevent, mitigate or respond to a threat. NTAS Alerts will include a clear statement on the nature of the threat, which will be defined in one of two ways:

"Elevated Threat": Warns of a credible terrorist threat against the United States

"Imminent Threat": Warns of a credible, specific, and impending terrorist threat against the United States

NTAS Alerts

After reviewing the available information, the Secretary of Homeland Security will decide, in coordination with other Federal entities, whether an NTAS Alert should be issued.

Imminent Threat Alert

Warns of a credible, specific, and impending terrorist threat against the United States.

Elevated Threat Alert

Warns of a credible terrorist threat against the United States.

NTAS Alerts will only be issued when credible information is available.

These alerts will include a clear statement that there is an imminent threat or elevated threat. Using available information, the alerts will provide a concise summary of the potential threat, information about actions being taken to ensure public safety, and recommended steps that individuals, communities, businesses and governments can take to help prevent, mitigate or respond to the threat.

The NTAS Alerts will be based on the nature of the threat: in some cases, alerts will be sent directly to law enforcement or affected areas of the private sector, while in others, alerts will be issued more broadly to the American people through both official and media channels.

Sunset Provision

An individual threat alert is issued for a specific time period and then automatically expires. It may be extended if new information becomes available or the threat evolves.

NTAS Alerts contain a sunset provision indicating a specific date when the alert expires - there will not be a constant NTAS Alert or blanket warning that there is an overarching threat. If threat information changes for an alert, the Secretary of Homeland Security may announce an updated NTAS Alert. All changes, including the announcement that cancels an NTAS Alert, will be distributed the same way as the original alert.

The NTAS Alert – How can you help?

Each alert provides information to the public about the threat, including, if available, the geographic region, mode of transportation, or critical infrastructure potentially affected by the threat; protective actions being taken by authorities, and steps that individuals and communities can take to protect themselves and their families, and help prevent, mitigate or respond to the threat.

Terrorism Information

Terrorism information and intelligence is based on the collection, analysis and reporting of a range of sources and methods. While intelligence may indicate that a

threat is credible, specific details may still not be known. As such, Americans should continue to stay informed and vigilant throughout the duration of an NTAS Alert.

Citizens should report suspicious activity to their local law enforcement authorities. The “If You See Something, Say Something” campaign across the United States encourages all citizens to be vigilant for indicators of potential terrorist activity, and to follow NTAS Alerts for information about threats in specific places or for individuals exhibiting certain types of suspicious activity.

Visit www.dhs.gov/ifyouseesomethingsaysomething to learn more about the campaign.

Alert Announcements

NTAS Alerts will be issued through state, local and tribal partners, the news media and directly to the public via the following channels:

- Via the official DHS NTAS webpage – <http://www.dhs.gov/alerts>
- Via email signup at – <http://www.dhs.gov/alerts>
- Via social media
 - o Facebook – <http://facebook.com/NTASAlerts>
 - o Twitter – <http://www.twitter.com/NTASAlerts>

- Via data feeds, web widgets and graphics o <http://www.dhs.gov/alerts>

The public can also expect to see alerts in places, both public and private, such as transit hubs, airports and government buildings.

Frequently Asked Questions

Q – What will happen to the color-coded advisory system?

A - The new National Terrorism Advisory System replaces the Homeland Security Advisory System that has been in place since 2002. The National Terrorism Advisory System, or NTAS, will include information specific to the particular credible threat, and will not use a color-coded scale.

Q – How does the new system work?

A – When there is credible information about a threat, an NTAS Alert will be shared with the American public. It may include specific information, if available, about the nature of the threat, including the geographic region, mode of transportation, or critical infrastructure potentially affected by the threat, as well as steps that individuals and communities can take to protect themselves and help prevent, mitigate or respond to the threat.

The advisory will clearly indicate whether the threat is Elevated, if we have no specific information about the timing or location, or Imminent, if we believe the threat is impending or very soon.

Q – As a citizen, how will I find out that an NTAS Alert has been announced?

A – The Secretary of Homeland Security will announce the alerts publically. Alerts will simultaneously be posted at DHS.gov/alerts and released to the news media for distribution. The Department of Homeland Security will also distribute alerts across its social media channels, including the Department’s blog, Twitter stream, Facebook page, and RSS feed.

Q - What should Americans do when an NTAS Alert is announced?

A – The NTAS Alert informs the American public about credible terrorism threats, and encourages citizens to report suspicious activity. Where possible and applicable, NTAS Alerts will include steps that individuals and communities can take to protect themselves to help prevent, mitigate or respond to the threat. Individuals should review the information contained in the alert, and based upon the circumstances, take the recommended precautionary or preparedness measures for themselves and their families.

Q – How should I report suspicious activity?

A – Citizens should report suspicious activity to their local law enforcement authorities. The “If You See Something, Say Something” campaign across the United States encourages all citizens to be vigilant for indicators of potential terrorist activity, and to follow NTAS Alerts for information about threats in specific places or for individuals exhibiting certain types of suspicious activity.

Q - I get my news online, so how will I find out about an NTAS Alert?

A – Americans can go to DHS.gov/alerts to see the most recent advisories. Additionally, advisories will be sent out widely through social and mainstream media.

7. Q - How will NTAS Alerts be cancelled or updated?

A – The NTAS Alerts carry an expiration date and will be automatically cancelled on that date. If the threat information changes for an alert, the Secretary of Homeland Security may announce an updated NTAS Alert. All changes, including the announcement that cancels an NTAS Alert, will be distributed the same way as the original alert.

8. Q - Do these alerts apply to Americans in other countries?

A – NTAS Alerts apply only to threats in the United States and its possessions. The Department of State issues security advisory information for U.S. citizens overseas or traveling in foreign countries.

If You See Something, Say Something Report suspicious activity to local law enforcement or call 911. The National Terrorism Advisory System provides Americans with alert information on homeland security threats. It is distributed by the Department of Homeland Security. More information is available at: www.dhs.gov/alerts. To receive mobile updates: www.twitter.com/NTASAlerts

STAY INFORMED

- This section notifies the public about where to get more information.
- It encourages citizens to stay informed about updates from local public safety and community leaders.
- It includes a link to the DHS NTAS website <http://www.dhs.gov/alerts> and <http://twitter.com/NTASAlerts>

AFFECTED AREAS

This section includes visual depictions (such as maps or other graphics) showing the affected location(s), sector(s), or other illustrative detail about the threat itself.

DURATION

An individual threat alert is issued for a specific time period and then automatically expires. It may be extended if new information becomes available or the threat evolves.

DETAILS

- This section provides more detail about the threat and what the public and sectors need to know.
- It may include specific information, if available, about the nature and credibility of the threat, including the critical infrastructure sector(s) or location(s) that may be affected.
- It includes as much information as can be released publicly about actions being taken or planned by authorities to ensure public safety, such as increased protective actions and what the public may expect to see.

SUMMARY

The Secretary of Homeland Security informs the public and relevant government and private sector partners about a potential or actual threat with this alert, indicating whether there is an “imminent” or “elevated” threat. If You See Something Say Something used with permission of the NY Metropolitan Transportation Authority.
DATE & TIME ISSUED: XXXX

Homeland Security Defined (Older Policy, new policy is still being refined)

In the aftermath of September 11, “**homeland security**” has come to mean many things to many people. It is a new mission and a new term. The federal government defines homeland security as follows:

Each phrase in the definition has meaning.

Concerted national effort. The federal government has a critical role to play in homeland security. Yet the nature of American society and the structure of American governance make it impossible to achieve the goal of a secure homeland through federal executive branch action alone.

The Administration’s approach to homeland security is based on the principles of shared responsibility and partnership with the Congress, state and local governments, the private sector, and the American people.

The ***National Strategy for Homeland Security*** belongs and applies to the Nation as a whole, not just to the President’s proposed Department of Homeland Security or the federal government.

Prevent. The first priority of homeland security is to prevent terrorist attacks. The United States aims to deter all potential terrorists from attacking America through our uncompromising commitment to defeating terrorism wherever it appears. We also strive to detect terrorists before they strike, to prevent them and their instruments of terror from entering our country, and to take decisive action to eliminate the threat they pose. These efforts—which will be described in both the ***National Strategy for Homeland Security*** and the ***National Strategy for Combating Terrorism***—take place both at home and abroad. The nature of modern terrorism requires a global approach to prevention.

The ***National Strategy for Homeland Security*** attaches special emphasis to preventing, protecting against, and preparing for catastrophic threats. The greatest risk of mass casualties, massive property loss, and immense social disruption comes from weapons of mass destruction, strategic information warfare, attacks on critical infrastructure, and attacks on the highest leadership of government.

Terrorist attacks. Homeland security is focused on terrorism in the United States. The ***National Strategy for Homeland Security*** characterizes terrorism as any premeditated, unlawful act dangerous to human life or public welfare that is intended to intimidate or coerce civilian populations or governments.

This description captures the core concepts shared by the various definition of terrorism contained in the U.S. Code, each crafted to achieve a legal standard of specificity and clarity.

This description covers kidnappings; hijackings; shootings; conventional bombings; attacks involving chemical, biological, radiological, or nuclear weapons; cyber-attacks; and any number of other forms of malicious violence. Terrorists can be U.S. citizens or foreigners, acting in concert with others, on their own, or on behalf of a hostile state.

Reduce America's vulnerability. Homeland security involves a systematic, comprehensive, and strategic effort to reduce America's vulnerability to terrorist attack. We must recognize that as a vibrant and prosperous free society, we present an ever-evolving, ever-changing target.

As we shore up our defenses in one area, the terrorists may exploit vulnerabilities in others. The **National Strategy for Homeland Security**, therefore, outlines a way for the government to work with the private sector to identify and protect our critical infrastructure and key assets, detect terrorist threats, and augment our defenses.

Because we must not permit the threat of terrorism to alter the American way of life, we have to accept some level of terrorist risk as a permanent condition. We must constantly balance the benefits of mitigating this risk against both the economic costs and infringements on individual liberty that this mitigation entails. No mathematical formula can reveal the appropriate balance; it must be determined by politically accountable leaders exercising sound, considered judgment informed by top-notch scientists, medical experts, and engineers.

Homeland security. Is a concerted national effort to prevent terrorist attacks within the United States, reduce America's vulnerability to terrorism, and minimize the damage and recover from attacks that do occur.

Minimize the damage. The United States will prepare to manage the consequences of any future terrorist attacks that may occur despite our best efforts at prevention.

Therefore, homeland security seeks to improve the systems and prepare the individuals that will respond to acts of terror. The **National Strategy for Homeland Security** recognizes that after an attack occurs, our greatest chance to minimize loss of life and property lies with our local first responders—police officers, firefighters, emergency medical providers, public works personnel, and emergency management officials. Many of our efforts to minimize the damage focus on these brave and dedicated public servants.

Recover. As an essential component of homeland security, the United States will build and maintain various financial, legal, and social systems to recover from all forms of terrorism.

We must, therefore, be prepared to protect and restore institutions needed to sustain economic growth and confidence, rebuild destroyed property, assist victims and their families, heal psychological wounds, and demonstrate compassion, recognizing that we cannot automatically return to the pre-attack norm.



How easy is it to tap into your water, sewer or gas lines? Very easy...

For facilities, personnel, and operations inside the territorial United States, all Federal departments, agencies, and offices other than military facilities shall conform their existing threat advisory systems to this system, and henceforth administer their systems consistent with the determination of the Attorney General with regard to the Threat Condition in effect.

Every utility should have a security system in place including a waste-water treatment plant. Two security “keys” are *hardening* and *surveillance* of your facility. Video and sound surveillance are only as good as your equipment and the operator.



If you choose a video, I'll suggest you to use a digital format. It leaves a “watermark” to insure authentication.

Digital cameras can see 50 miles and record only whenever there is an “activity”. This recording can be placed on a DVD. There are now infrared cameras for areas with low lighting or no lighting. Don't expect to see cameras any longer. Technology has allowed camera to be completely hidden from view. By 2014, you will no longer see any cameras at all.

The water system is the easiest target to harm the large amount of people and cause fear. The CIA has found plans for terrorism, but we also have to think about the homegrown nutcase that wants to get even with the world.

Bio-Chemical Terror

The threat of bio-chemical terror has initiated a revolution in security thinking.

Until new portable sensor technology is available, security forces and water treatment plants have very little control - beyond intelligence sources - of the transfer of lethal materials. Only small quantities are required for great effect. These can be contained in plastic or glass and thus pass freely through metal -detectors or x-ray devices. Their proximity in appearance to pharmaceuticals, perfumeries, cosmetics is such that a primitive labeling would not give unbraided security personnel cause for suspicion. Many of these agents can be designed in aerosol form and can be silently distributed through unguarded air-condition systems.

Anthrax and Biological Agents

In its crude form anthrax can be manufactured in-house using widely-available biological skills and materials. An extremely infectious disease found in livestock, inhalation causes flu-like symptoms followed for a number of days followed by a brief respite while the disease lies dormant, then the onset of respiratory failure, shock and death. Vaccinations are presently being upgraded in the US to include the full range of anthrax types. American special units and general emergency personnel are to receive vaccinations in addition to soldiers.

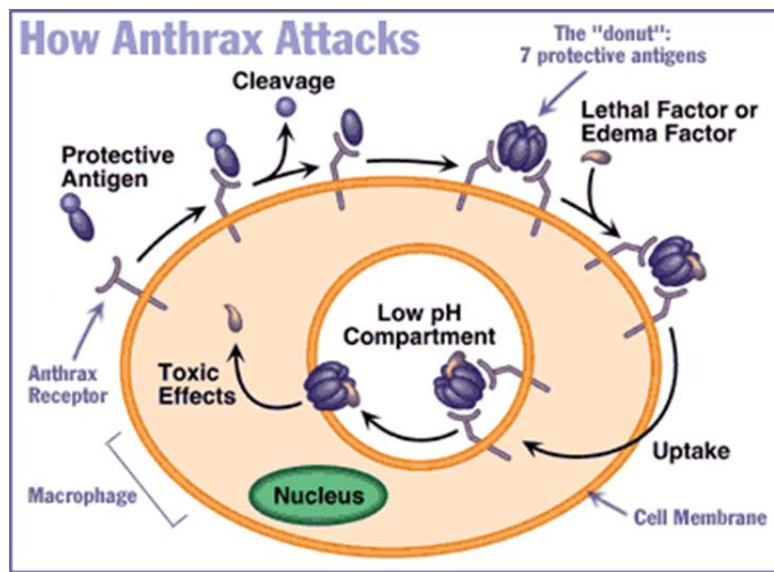

Certain antibiotics together with antidote are to some degree effective in treating although how far is still highly uncertain (tests for strains have been done only on animals). Treating effectively, for the very old and very young (the vulnerable heart of the civilian frontier) is extremely doubtful. Moreover, treatment should begin immediately- creating problems in the event of an undeclared attack (90 percent fatality). Like many other biological killers anthrax spores can be contained in plastic aerosol form.

Most of America's enemies have anthrax stockpiles. Terrorist groups in the Middle East and their supporters have shown a keen interest in the virus that has claimed the spotlight of the American media. Other Biological agents cultivated for terrorist use include: Botulism, plague, Ricin and Aflatoxin. Where Americans have reason to fear a large scale (mass casualty) attack - a single crop sprayer over a major city could kill 3 million.

Biological weapons can be used in many different ways in a variety of scenarios: for example, Ricin is a deadly toxin that could be used for assassinations; insects could be used to spread deadly diseases; food or water supplies could be contaminated.

Biological Agents

Undoubtedly, however, rapid, large-scale anti- personnel use of biological agents requires their dissemination through the air and inhalation into the lungs. When used effectively in this way biological weapons have an area coverage which makes them equivalent to nuclear weapons as weapons of mass destruction. There are many estimates in the open literature that confirm this conclusion.

For example, the Office of Technology Assessment of the United States Congress has calculated that a mere 100 kg of anthrax spores, spread as a line source and allowed to drift on the wind on a clear, calm night over Washington DC, could kill between 1 and 3 million people. The difference between nuclear and biological weapons of mass destruction, as the Iraqi example clearly demonstrates, is that it is much easier and cheaper to produce a biological weapons arsenal. The ease with which such agents can be produced means that they could also be available to rogue states or even sub-state terrorist groups. It is known that the Japanese sect which used Sarin nerve gas against commuters on the Tokyo underground were also interested in the use of anthrax.

Anthrax

Anthrax is one of a group of so-called '*classical*' biological warfare agents. It was weaponized in the US offensive biological weapons program, which ran from 1942 to 1969. Anthrax is an obvious agent of choice because it forms a spore which is resistant to environmental damage. Also, as the Joint CB Technical Data Source Book pointed out (6): "**...The mortality rate for respiratory anthrax is essentially 100 per cent. Since early diagnosis of inhalation anthrax is unlikely, treatment with antibiotics is ineffective...**"

Nevertheless, there was doubt about the utility of biological weapons during the Cold War period when biological weapons were often seen as unpredictable and uncontrollable. Yet a senior UK official specifically rejected this view in an article in the Journal of the Royal United Services Institute in 1992. He argued that by 1969 (7): "**...The utility of BW had been demonstrated by all means, short of use in war, and the established feasibility could clearly not become disestablished with time...**"

Moreover, the threat from biological weapons has continued to develop since 1969. Infectious diseases caused by microbial agents - bubonic plague, cholera, influenza, leprosy, measles, smallpox, tuberculosis, typhoid fever, typhus, yellow fever etc. - have long created misery for human populations in both peace and war. And sporadic attempts have been made in the past to deliberately use disease as a weapon of war: the British, for example, gave Native American Indians blankets contaminated with smallpox. Yet, it was only towards the end of the last century that scientific understanding of these diseases and their agents began to develop. Inevitably, perhaps, this precise new knowledge was applied in warfare, an example being the attempts by both sides in the First World War to infect vital stocks of horses with the disease glanders.



The large-scale Japanese, British, and American offensive biological weapons programs then followed in the 1930s, '40s, '50s, and '60s. Knowledge of bacteria developed faster than that of viruses and it seems probable that the Soviet/Russian program, which was only officially terminated in the 1990s, would have benefited from the growing knowledge of viral agents and diseases. Only in the early 1970s did genetic engineering - the effective transfer of functional genes across species - become possible and the growth of modern biotechnology began.

Genetic engineering, as is well recognized, allows the easier production of militarily significant quantities of toxins. Essentially, it has become possible to produce strategic weapons, using very limited physical and financial resources, with a relatively small number of trained personnel. It also allows the possibility of enhancing the characteristics of biological warfare agents in order to improve their environmental stability, their infectivity, and their resistance to antibiotics. Humans have long been involved in modifying others species by deliberate, selective breeding, for example to produce the vast range of modern dog varieties.

But the difference between this traditional activity and modern capabilities, like making a human gene function in a bacterium, can hardly be overstated. These dangers are clearly set out in the background scientific papers produced for the Fourth Review Conference of the Biological Weapons Convention in 1996. It was also recognized at the Review Conference that the Human Genome Project, which will deliver a complete account of the structure of our genetic material by the early years of the next century, could pose new dangers. A number of analysts have argued that knowledge of the human genome at this level, combined with the obvious diversity of human groups, and the current advances in gene therapy, could perhaps allow the development of '*ethnic*' biological weapons targeted at specific groups.

There is, additionally, an obvious danger that our growing knowledge of bioregulatory peptides will allow the development of a new range of anti-personnel agents. Such misuse of biological knowledge could happen if the international community is unable to enforce the disarmament norm embodied in the Biological Weapons Convention. Also, our over-confidence (as a species) that we have beaten microbial pathogens has been severely dented. The phenomenon of drug-resistant tuberculosis has epitomized the threat that could affect any of us even in the developed world. Microbial pathogens can evolve very quickly to evade the defenses we erect. Alongside this renewed threat from '*old*' diseases, there are new threats from diseases with frightening characteristics, such as Ebola, as the human population expands and moves in large numbers into different ecosystems.

The analysis of the threats we face today is much more complex than a decade ago, and potential errors that could lead to worst-case analyses abound, but as two naval analysts recently pointed out: "***Functional distortion in intelligence analysis amounts to de-emphasis of security threats that may be acknowledged and real, but which existing forces can do little about, or that cannot be countered without significant investment in capabilities that differ from those in hand...***"

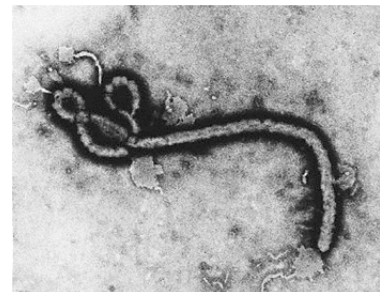

Ebola

Ignoring the very real dangers in the evolving threat from biological agents would appear to fit into this precise category of distortion, and the consequences of that mistake could be extremely dangerous. Yet, if the problem is recognized and properly prioritized, a great deal can be done to reinforce the norm of international behavior embodied in the Biological and Toxin Weapons Convention.

At a scientific level, for example, our ability to detect and identify agents and toxins has increased considerably in recent years. Alongside rapid increases in specific knowledge about individual disease agents, broader generalizations about the mechanisms of pathogenicity are becoming possible. This should increasingly allow a more generic approach to be taken in dealing with emerging threats.

An interesting example of what might become possible is the Unconventional Pathogen Countermeasures Program in the Defense Sciences Office of the US Defense Advanced Research Projects Agency (**DARPA**). This program is seeking novel and unconventional methods of providing protection against pathogens used adversarially.

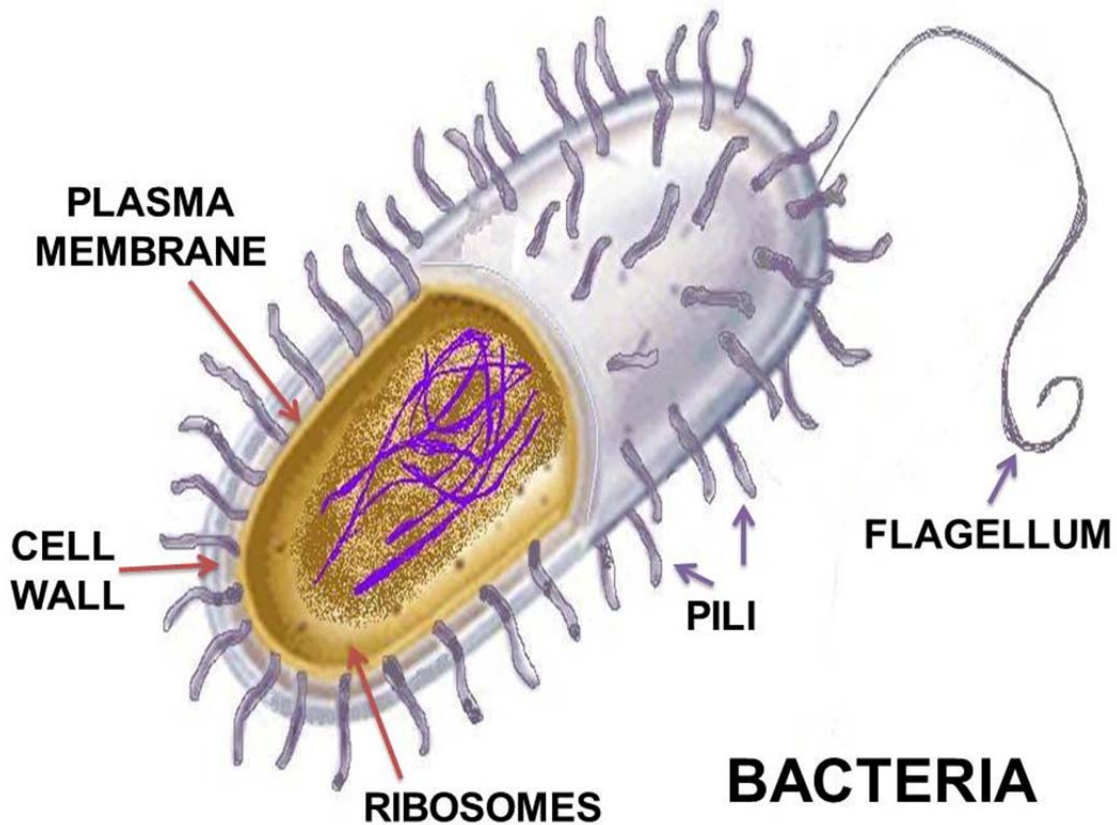

Table 1. Critical Biological Agent Categories for Public Health Preparedness

Biological agent(s)	Disease
Category A	
<i>Variola major</i>	Smallpox
<i>Bacillus anthracis</i>	Anthrax
<i>Yersinia pestis</i>	Plague
<i>Clostridium botulinum</i> (botulinum toxins)	Botulism
<i>Francisella tularensis</i>	Tularemia
Filoviruses and Arenaviruses (e.g., <i>Ebola virus</i> , <i>Lassa virus</i>)	Viral hemorrhagic fevers
Category B	
<i>Coxiella burnetii</i>	Q fever
<i>Brucella</i> spp.	Brucellosis
<i>Burkholderia mallei</i>	Glanders
<i>Burkholderia pseudomallei</i>	Melioidosis
Alphaviruses (VEE, EEE, WEE ^a)	Encephalitis
<i>Rickettsia prowazekii</i>	Typhus fever
Toxins (e.g., Ricin, Staphylococcal enterotoxin B)	Toxic syndromes
<i>Chlamydia psittaci</i>	Psittacosis
Food safety threats (e.g., <i>Salmonella</i> spp., <i>Escherichia coli</i> O157:H7)	
Water safety threats (e.g., <i>Vibrio cholerae</i> , <i>Cryptosporidium parvum</i>)	
Category C	
Emerging threat agents (e.g., <i>Nipah virus</i> , hantavirus)	

^aVenezuelan equine (VEE), eastern equine (EEE), and western equine encephalomyelitis (WEE) viruses

Table 2. Criteria and weighting^a used to evaluate potential biological threat agents

Disease	Public health impact		Dissemination potential		Public perception	Special preparation	Category
	Disease	Death	P-D ^b	P - P ^c			
Smallpox	+	++	+	+++	+++	+++	A
Anthrax	++	+++	+++	0	+++	+++	A
Plague ^d	++	+++	++	++	++	+++	A
Botulism	++	+++	++	0	++	+++	A
Tularemia	++	++	++	0	+	+++	A
VHF ^e	++	+++	+	+	+++	++	A
VE ^f	++	+	+	0	++	++	B
Q Fever	+	+	++	0	+	++	B
Brucellosis	+	+	++	0	+	++	B
Glanders	++	+++	++	0	0	++	B
Melioidosis	+	+	++	0	0	++	B
Psittacosis	+	+	++	0	0	+	B
Ricin toxin	++	++	++	0	0	++	B
Typhus	+	+	++	0	0	+	B
Cholera ^g	+	+	++	+/-	+++	+	B
Shigellosis ^g	+	+	++	+	+	+	B

^aAgents were ranked from highest threat (+++) to lowest (0).

^bPotential for production and dissemination in quantities that would affect a large population, based on availability, BSL requirements, most effective route of infection, and environmental stability.

^cPerson-to-person transmissibility.

^dPneumonic plague.

^eViral hemorrhagic fevers due to Filoviruses (*Ebola*, *Marburg*) or Arenaviruses (e.g., *Lassa*, *Machupo*).

^fViral encephalitis.

^gExamples of food- and waterborne diseases.

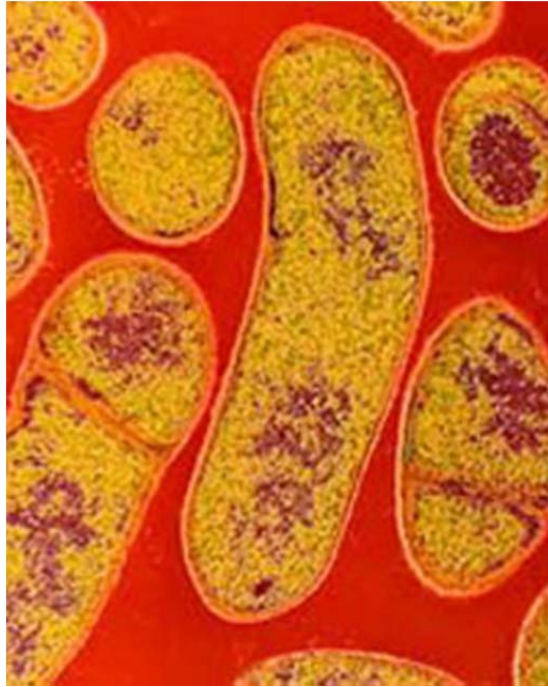

Botulism, wrinkle remover and general people remover too.



Plague, it is black and back. We will see all these old diseases coming back in the next couple of years.

Safe Drinking Water Act Terms Chapter 2

Community Water System (CWS). A public water system that serves at least 15 service connections used by year-round residents of the area served by the system or regularly serves at least 25 year-round residents.

Class V Underground Injection Control (UIC). Rule A rule under development covering wells not included in Class I, II, III or IV in which nonhazardous fluids are injected into or above underground sources of drinking water.

Contamination Source Inventory. The process of identifying and inventorying contaminant sources within delineated source water protection areas through recording existing data, describing sources within the source water protection area, targeting likely sources for further investigation, collecting and interpreting new information on existing or potential sources through surveys, and verifying accuracy and reliability of the information gathered.

Cryptosporidium. A protozoan associated with the disease cryptosporidiosis in humans. The disease can be transmitted through ingestion of drinking water, person-to-person contact, or other exposure routes. Cryptosporidiosis may cause acute diarrhea, abdominal pain, vomiting, and fever that last 1-2 weeks in healthy adults, but may be chronic or fatal in immuno-compromised people.

Drinking Water State Revolving Fund (DWSRF). Under section 1452 of the SDWA, the EPA awards capitalization grants to states to develop drinking water revolving loan funds to help finance drinking water system infrastructure improvements, source water protection, to enhance operations and management of drinking water systems, and other activities to encourage public water system compliance and protection of public health.

Exposure. Contact between a person and a chemical. Exposures are calculated as the amount of chemical available for absorption by a person.

Giardia lamblia. A protozoan, which can survive in water for 1 to 3 months, associated with the disease giardiasis. Ingestion of this protozoan in contaminated drinking water, exposure from person-to-person contact, and other exposure routes may cause giardiasis. The symptoms of this gastrointestinal disease may persist for weeks or months and include diarrhea, fatigue, and cramps.

Ground Water Disinfection Rule (GWDR). Under section 107 of the SDWA Amendments of 1996, the statute reads, ". . . the Administrator shall also promulgate national primary drinking water regulations requiring disinfection as a treatment technique for all public water systems, including surface water systems, and as necessary, ground water systems."

Maximum Contaminant Level (MCL). In the SDWA, an MCL is defined as "*the maximum permissible level of a contaminant in water which is delivered to any user of a public water system.*" MCLs are enforceable standards.

Maximum Contaminant Level Goal (MCLG). The maximum level of a contaminant in drinking water at which no known or anticipated adverse effect on the health effect of persons would occur, and which allows for an adequate margin of safety. MCLGs are non-enforceable public health goals.

Nephelometric Turbidity Units (NTU). A unit of measure used to describe the turbidity of water. Turbidity is the cloudiness in water.

Nitrates. Inorganic compounds that can enter water supplies from fertilizer runoff and sanitary wastewater discharges. Nitrates in drinking water are associated with methemoglobinemia, or blue baby syndrome, which results from interferences in the blood's ability to carry oxygen.

Non-Community Water System (NCWS). A public water system that is not a community water system. There are two types of NCWSs: transient and non-transient.

Organics. Chemical molecules contain carbon and other elements such as hydrogen. Organic contaminants of concern to drinking water include chlorohydrocarbons, pesticides, and others.

Phase I Contaminants. The Phase I Rule became effective on January 9, 1989. This rule, also called the Volatile Organic Chemical Rule, or VOC Rule, set water quality standards for 8 VOCs and required all community and Non-Transient, Non-Community water systems to monitor for, and if necessary, treat their supplies for these chemicals. The 8 VOCs regulated under this rule are: Benzene, Carbon Tetrachloride, para-dichlorobenzene, trichloroethylene, vinyl chloride, 1,1,2-trichloroethane, 1,1-dichloroethylene, and 1,2-dichloroethane.

Per capita. Per person; generally used in expressions of water use, gallons per capita per day (gpcd).

Point-of-Use Water Treatment. Refers to devices used in the home or office on a specific tap to provide additional drinking water treatment.

Point-of-Entry Water Treatment. Refers to devices used in the home where water pipes enter to provide additional treatment of drinking water used throughout the home.

Primacy State State that has the responsibility for ensuring a law is implemented, and has the authority to enforce the law and related regulations. State has adopted rules at least as stringent as federal regulations and has been granted primary enforcement responsibility.

Radionuclides. Elements that undergo a process of natural decay. As radionuclides decay, they emit radiation in the form of alpha or beta particles and gamma photons. Radiation can cause adverse health effects, such as cancer, so limits are placed on radionuclide concentrations in drinking water.

Risk. The potential for harm to people exposed to chemicals. In order for there to be risk, there must be hazard and there must be exposure.

SDWA - The Safe Drinking Water Act. The Safe Drinking Water Act was first passed in 1974 and established the basic requirements under which the nation's public water supplies were regulated. The US Environmental Protection Agency (**EPA**) is responsible for setting the national drinking water regulations, while individual states are responsible for ensuring that public water systems under their jurisdiction are complying with the regulations. The SDWA was amended in 1986 and again in 1996.

Significant Potential Source of Contamination. A facility or activity that stores, uses, or produces chemicals or elements, and that has the potential to release contaminants identified in a state program (contaminants with MCLs plus any others a state considers a health threat) within a source water protection area in an amount which could contribute significantly to the concentration of the contaminants in the source waters of the public water supply.

Sole Source Aquifer (SSA) Designation. The surface area above a sole source aquifer and its recharge area.

Source Water Protection Area (SWPA). The area delineated by the state for a PWS or including numerous PWSs, whether the source is ground water or surface water or both, as part of the state SWAP approved by the EPA under section 1453 of the SDWA.

Sub-watershed. A topographic boundary that is the perimeter of the catchment area of a tributary of a stream.

State Source Water Petition Program. A state program implemented in accordance with the statutory language at section 1454 of the SDWA to establish local voluntary incentive-based partnerships for SWP and remediation.

State Management Plan (SMP) Program. A state management plan under FIFRA required by the EPA to allow states (e.g. states, tribes and U.S. territories) the flexibility to design and implement approaches to manage the use of certain pesticides to protect ground water.

Surface Water Treatment Rule (SWTR). The rule specifies maximum contaminant level goals for *Giardia lamblia*, viruses and *Legionella*, and promulgated filtration and disinfection requirements for public water systems using surface water sources, or by ground water sources under the direct influence of surface water. The regulations also specify water quality, treatment, and watershed protection criteria under which filtration may be avoided.

Susceptibility Analysis. An analysis to determine, with a clear understanding of where the significant potential sources of contamination are located, the susceptibility of the public water systems in the source water protection area to contamination from these sources. This analysis will assist the state in determining which potential sources of contamination are "significant."

To the Extent Practical. States must inventory sources of contamination to the extent they have the technology and resources to complete an inventory for a Source Water Protection Area delineated as described in the guidance. All information sources may be used, particularly previous Federal and state inventories of sources.

Transient/Non-Transient, Non-Community Water Systems (T/NT, NCWS). Water systems that are non-community systems: transient systems serve 25 non-resident persons per day for 6 months or less per year. Transient non-community systems typically are restaurants, hotels, large stores, etc. Non-transient systems regularly serve at least 25 of the same non-resident persons per day for more than 6 months per year. These systems typically are schools, offices, churches, factories, etc.

Treatment Technique. A specific treatment method required by the EPA to be used to control the level of a contaminant in drinking water. In specific cases where the EPA has determined it is not technically or economically feasible to establish an MCL, the EPA can

instead specify a treatment technique. A treatment technique is an enforceable procedure or level of technical performance which public water systems must follow to ensure control of a contaminant.

Total Coliform. Bacteria that are used as indicators of fecal contaminants in drinking water.

Toxicity. The property of a chemical to harm people who come into contact with it.

Underground Injection Control (UIC) Program. The program is designed to prevent underground injection which endangers drinking water sources. The program applies to injection well owners and operators on Federal facilities, Native American lands, and on all U.S. land and territories.

Watershed. A topographic boundary area that is the perimeter of the catchment area of a stream.

Watershed Approach. A watershed approach is a coordinating framework for environmental management that focuses public and private sector efforts to address the highest priority problems within hydrologically-defined geographic areas, taking into consideration both ground and surface water flow.

Watershed Area. A topographic area that is within a line drawn connecting the highest points uphill of a drinking water intake, from which overland flow drains to the intake.

Wellhead Protection Area (WHPA). The surface and subsurface area surrounding a well or well field, supplying a PWS, through which contaminants are reasonably likely to move toward and reach such water well or well field.

More SDWA Information

Any federal agency having jurisdiction over federally owned and maintained public water systems must comply with all federal, state, and local drinking water requirements as well as any underground injection control programs (Section 1447). The Act provides for waivers in the interest of national security.

Procedures for judicial review are outlined (Section 1448), and provision for citizens' civil actions is made (Section 1449). Citizen suits may be brought against any person or agency allegedly in violation of provisions of the Act, or against the Administrator for alleged failure to perform any action or duty which is not discretionary.

EPA may use the new estrogenic substances screening program created in the Food Quality Protection Act of 1996 (P.L. 104-170) to provide for testing of substances that may be found in drinking water if the Administrator determines that a substantial population may be exposed to such substances (Section 1457).

EPA is directed to conduct drinking water studies involving subpopulations at greater risk and biological mechanisms, and studies to support several rules including those addressing D/DBPs and **Cryptosporidium**. The Centers for Disease Control and Prevention and EPA must conduct pilot waterborne disease occurrence studies by August 1998. (Section 1458).

The Act includes a provision amending the Federal Food, Drug, and Cosmetic Act, generally requiring the Secretary of Health and Human Services to issue bottled drinking water standards for contaminants regulated under the Safe Drinking Water Act.

Other provisions of P.L. 104-182 authorize water and wastewater grants for *colonias* and Alaska rural and native villages, and authorize the transfer of the Washington (D.C.) Aqueduct to a regional authority.

The 1996 Amendments also authorize a \$50 million per year grant program for additional infrastructure and watershed protection projects; the conference report lists, and directs EPA to give priority consideration to, 24 such projects.



IDEXX's SimPlate for HPC method is used for the quantification of heterotrophic plate count (HPC) in water. It is based on the Multiple Enzyme Technology which detects viable bacteria in water by testing for the presence of key enzymes known to be present in these little organisms. This technique uses enzyme substrates that produce a blue fluorescence when metabolized by waterborne bacteria. The sample and media are added to a SimPlate Plate, incubated and then examined for fluorescing wells. The number of wells corresponds to a Most Probable Number (MPN) of total bacteria in the original sample. The MPN values generated by the SimPlate for HPC method correlate with the Pour Plate method using the Total Plate Count Agar, incubated at 35°C for 48 hours as described in *Standard Methods for the Examination of Water and Wastewater, 19th Edition*.

We will be more into detail in the Water Monitoring Section.

Microbes

Coliform bacteria are common in the environment and are generally not harmful. However, the presence of these bacteria in drinking water are usually a result of a problem with the treatment system or the pipes which distribute water, and indicates that the water may be contaminated with germs that can cause disease.

Fecal Coliform and E. coli are bacteria whose presence indicates that the water may be contaminated with human or animal wastes. Microbes in these wastes can cause short-term effects, such as diarrhea, cramps, nausea, headaches, or other symptoms.

Cryptosporidium is a parasite that enters lakes and rivers through sewage and animal waste. It causes cryptosporidiosis, a mild gastrointestinal disease. However, the disease can be severe or fatal for people with severely weakened immune systems. The EPA and CDC have prepared advice for those with severely compromised immune systems who are concerned about **Cryptosporidium**.

Giardia lamblia is a parasite that enters lakes and rivers through sewage and animal waste. It causes gastrointestinal illness (e.g. diarrhea, vomiting, and cramps).



Counting water fleas is just one daily task for many water treatment operators. Water Fleas or *Daphnia* are small crustaceans and great bio-indicators. Changes in heart rate might suggest a chemical compound has a physiological effect, and more importantly-*Daphnia Magna* is used to measure the toxicity of a chemical compound in water (LD50 measurements).

Safe Drinking Water Act (SDWA)

On August 6, 1996, President Clinton signed the Reauthorization of the Safe Drinking Water Act, bringing to a successful conclusion to years of work on the part of water professionals and a broad range of public interest groups throughout the nation. This law strikes a balance among federal, state, local, urban, rural, large and small water systems in a manner that improves the protection of public health and brings reason and good science to the regulatory process.



The major elements of this law include:

- The law updates the standard-setting process by focusing regulations on contaminants known to pose greater public health risks.
- It replaces the current law's demand for 25 new standards every three years with a new process based on occurrence, relative risk and cost-benefit considerations.
- It also requires the EPA to select at least five new candidate contaminants to consider for regulation every five years.
- The EPA is directed to require public water systems to provide customers with annual "**Consumer Confidence Reports**" in newspapers and by direct mail.
- The reports must list levels of regulated contaminants along with Maximum Contaminant Levels (**MCLs**) and Maximum Contaminant Level Goals (**MCLGs**), along with plainly worded definitions of both.
- The reports must also include a plainly worded statement of the health concerns for any contaminants for which there has been a violation, describe the utility's sources of

drinking water and provide data on unregulated contaminants for which monitoring is required, including *Cryptosporidium* and radon.

- The EPA must establish a toll-free hot line customers can call to get additional information.
- The EPA is required to publish guidelines for states to develop water source assessment programs that delineate protection areas and assess contamination risks.
- The EPA is required to identify technologies that are affordable for small systems to comply with drinking water regulations.
- Technical assistance funds and Small System Technical Assistance Centers are authorized to meet the training and technical needs of small systems.
- States are authorized to grant variances for compliance with drinking water regulations for systems serving 3,300 or fewer persons.
- The EPA is required to publish certification guidelines for operators of community and nontransient noncommunity public water systems.
- States that do not have operator certification programs that meet the requirements of the guidelines will lose 20 percent of their SRLF grant.
- A source water petition program for voluntary, incentive-based partnerships among public water systems and others to reduce contamination in source water is authorized.
- The law establishes a new State Revolving Loan Fund (**SRLF**) of \$1 billion per year to provide loans to public water systems to comply with the new SDWA.
- It also requires states to allocate 15 percent of the SRLF to systems serving 10,000 or fewer people unless no eligible projects are available for loans.
- It also allows states to jointly administer SDWA and Clean Water Act loan programs and transfer up to 33 percent between the two accounts.
- States must ensure that all new systems have compliance capacity and that all current systems maintain capacity, or lose 20 percent of their SRLF grant.

Although the EPA will continue to provide policy, regulations and guidance, state governments will now have more regulatory flexibility allowing for improved communication between water providers and their local regulators. Increased collaboration will result in solutions that work better and are more fully supported by the regulated community. States that have a source water assessment program may adopt alternative monitoring requirements to provide permanent monitoring relief for public water systems in accordance with EPA guidance.

Safe Drinking Water Act of 1974

(PL 93-523) as amended by:

- The Safe Drinking Water Act Amendments of 1986
- National Primary Drinking Water Regulations, 40 CFR 141
- National Interim Primary Drinking Water Regulations Implementation, 40 CFR 142
- National Secondary Drinking Water Regulations, 40 CFR 143

This is the primary Federal legislation protecting drinking water supplied by public water systems (those serving more than 25 people). The Environmental Protection Agency (**EPA**) is the lead agency and is mandated to set standards for drinking water. The EPA establishes national standards of which the states are responsible for enforcing.

The act provides for the establishment of primary regulations for the protection of the public health and secondary regulations relating to the taste, odor, and appearance of drinking water. Primary drinking water regulations, by definition, include either a maximum contaminant level (**MCL**) or, when a MCL is not economically or technologically feasible, a prescribed treatment technique which would prevent adverse health effects to humans.

An MCL is the permissible level of a contaminant in water that is delivered to any user of a public water system. Primary and secondary drinking water regulations are stated in 40 CFR 141 and 143, respectively. As amended in 1986, the EPA is required to set maximum contaminant levels for 83 contaminants deemed harmful to humans (with specific deadlines). It also has authority over groundwater. Water agencies are required to monitor water to ensure it meets standards.

National Drinking Water Regulations

The Act instructs the EPA on how to select contaminants for regulation and specifies how the EPA must establish national primary drinking water regulations once a contaminant has been selected (Section 1412). As of late 1996, the EPA had promulgated 84 drinking water regulations.

Contaminant Selection

P.L. 104-182 establishes a new process for the EPA to select contaminants for regulatory consideration based on occurrence, health effects, and meaningful opportunity for health risk reduction. By February 1998 and every 5 years thereafter, the EPA must publish a list of contaminants that may warrant regulation. Every 5 years thereafter, the EPA must determine whether or not to regulate at least 5 of the listed contaminants. The Act directs the EPA to evaluate contaminants that present the greatest health concern and to regulate contaminants that occur at concentration levels and frequencies of public health concern. The law also includes a schedule for the EPA to complete regulations for disinfectants and disinfection byproducts (**D/DBPs**) and *Cryptosporidium* (a waterborne pathogen).

Standard Setting

Developing national drinking water regulations is a two-part process. For each contaminant that the EPA has determined merits regulation, the EPA must set a non-enforceable maximum contaminant level goal (**MCLG**) at a level at which no known or anticipated adverse health effects occur, and which allows an adequate margin of safety. The EPA must then set an enforceable standard, a maximum contaminant level (**MCL**), as close to the MCLG as is "**feasible**" using the best technology, treatment techniques, or other means available (taking costs into consideration).

Standards are generally based on technologies that are affordable for large communities; however, under P.L. 104-182, each regulation establishing an MCL must list any technologies, treatment techniques, or other means that comply with the MCL and that are affordable for three categories of small public water systems. The 1996 Amendments authorize the EPA to set a standard at other than the feasible level if the feasible level would lead to an increase in health risks by increasing the concentration of other contaminants or by interfering with the treatment processes used to comply with other SDWA regulations. In such cases, the standard or treatment techniques must minimize the overall health risk.

Also, when proposing a regulation, the EPA must now publish a determination as to whether or not the benefits of the standard justify the costs. If the EPA determines that the benefits do not justify the costs, the EPA may, with certain exceptions, promulgate a standard that maximizes health risk reduction benefits at a cost that is justified by the benefits.

Risk Assessment

P.L. 104-182 adds risk assessment and communication provisions to SDWA. When developing regulations, the EPA is now required to: (1) use the best available, peer-reviewed science and supporting studies and data; and (2) make publicly available a risk assessment document that discusses estimated risks, uncertainties, and studies used in the assessment. When proposing drinking water regulations, the EPA must publish a health risk reduction and cost analysis. The law permits the EPA to promulgate an interim standard without first preparing a benefit-cost analysis or making a determination as to whether the benefits of a regulation would justify the costs if the EPA determines that a contaminant presents an urgent threat to public health.

New regulations generally become effective 3 years after promulgation. Up to 2 additional years may be allowed if the EPA (or a state in the case of an individual system) determines the time is needed for capital improvements. Section 1412 includes specific provisions for arsenic, sulfate, and radon. The law authorizes states to grant Systems variances from a regulation if raw water quality prevents meeting the standards despite application of the best technology (Section 1415). A new provision authorizes small system variances based on best affordable technology. States may grant these variances to systems serving 3,300 or fewer persons if the system cannot afford to comply (through treatment, an alternative water source, or restructuring) and the variance ensures adequate protection of public health; states may grant variances to systems serving between 3,300 and 10,000 persons with EPA approval. To receive a small system variance, the system must install a variance technology identified by the EPA. The variance technology need not meet the MCL, but must protect public health. The EPA must identify variance technologies for existing regulations. Variances are not available for microbial contaminants. The Act also provides for exemptions if a regulation cannot be met for other compelling reasons (including costs) and if the system was in operation before the effective date of a standard or treatment requirement (Section 1416). An exemption is intended to give a public water system more time to comply with a regulation and can be issued only if it will not result in an unreasonable health risk. Small systems may receive exemptions for up to 9 years.

State Primacy

The primary enforcement responsibility for public water systems lies with the states, provided they adopt regulations as stringent as the national requirements, adopt authority for administrative penalties, develop adequate procedures for enforcement, maintain records, and create a plan for providing emergency water supplies (Section 1413). Currently, 55 of 57 states and territories have primacy authority. P.L. 104-182 authorizes \$100 million annually for EPA to make grants to states to carry out the public water system supervision program. States may also use a portion of their SRF grant for this purpose (Section 1443).

Whenever the EPA finds that a public water system in a state with primary enforcement authority does not comply with regulations, the Agency must notify the state and the system and provide assistance to bring the system into compliance. If the state fails to commence enforcement action within 30 days after the notification, the EPA is authorized to issue an administrative order or commence a civil action.

Nonprimacy State

In a non-primacy state, the EPA must notify an elected local official (if any has jurisdiction over the water system) before commencing an enforcement action against the system (Section 1414). Primacy states may establish alternative monitoring requirements to provide interim monitoring relief for systems serving 10,000 or fewer persons for most contaminants, if a contaminant is not detected in the first quarterly sample. States with approved source water protection programs may adopt alternative monitoring requirements to provide permanent monitoring relief to qualified systems for chemical contaminants (Section 1418).

P.L. 104-182 requires states to adopt programs for training and certifying operators of community and nontransient noncommunity systems. The EPA must publish guidelines specifying minimum standards for operator certification by February 1999. Two years thereafter, the EPA must withhold 20% of a state's SRF grant unless the state has an operator certification program (Section 1419). States are also required to establish capacity development programs based on EPA guidance.

State programs must include: 1) legal authority to ensure that new systems have the technical, financial, and managerial capacity to meet SDWA requirements; and 2) a strategy to assist existing systems that are experiencing difficulties to come into compliance. Beginning in 2001, the EPA is required to withhold a portion of SRF grants from states that do not have compliance development strategies (Section 1420).

Underground Injection Control

Another provision of the Act requires the EPA to promulgate regulations for state underground injection control (**UIC**) programs to protect underground sources of drinking water. These regulations contain minimum requirements for the underground injection of wastes in five well classes to protect underground sources of drinking water and to require that a state prohibit, by December 1977, any underground injection that was not authorized by state permit (Section 1421).

Ground Water Protection Grant Programs

The Act contains three additional ground water protection programs. Added in 1986, Section 1427 established procedures for demonstration programs to develop, implement, and assess critical aquifer protection areas already designated by the Administrator as sole source aquifers. Section 1428, also added in 1986, and established an elective state program for protecting wellhead areas around public water system wells.

If a state established a wellhead protection program by 1989, and the EPA approved the state's program, then the EPA may award grants covering between 50% and 90% of the costs of implementing the program. Section 1429, added by P.L. 104-182, authorizes the EPA to make 50% grants to states to develop programs to ensure coordinated and comprehensive protection of ground water within the states. Appropriations for these three programs and for LYIC state program grants are authorized starting back in FY2003.

Source Water Protection Programs

P.L. 104-182 broadens the pollution prevention focus of the Act to embrace surface water as well as ground water protection. New Section 1453 directs the EPA to publish guidance for states to implement source water assessment programs that delineate boundaries of assessment areas from which systems receive their water, and identify the origins of contaminants in delineated areas to determine systems' susceptibility to contamination.

States with approved assessment programs may adopt alternative monitoring requirements to provide systems with monitoring relief under Section 1418.

New Section 1454 authorizes a source water petition program based on voluntary partnerships between state and local governments. States may establish a program under which a community water system or local government may submit a source water quality partnership petition to the state requesting assistance in developing a voluntary partnership to: (1) reduce the presence of contaminants in drinking water; (2) receive financial or technical assistance; and (3) develop a long-term source water protection strategy. This section authorizes \$5 million each year for grants to states to support petition programs. Also, states may use up to 10% of their annual SRF capitalization grant for the source water assessment activities or for the petition program.

State Revolving Funds

Section 1452, added by P.L. 104-182 authorizes a State Revolving Loan Fund (SRF) program to help systems finance improvements needed to comply with drinking water regulations. The law authorizes the EPA to make grants to states to capitalize SDWA SRFs, which states then use to make loans to public water systems. States must match 20% of the federal grant.

Grants will be allotted to states using the formula for distributing state PWSS grants through FY1997; then, grants will be allotted based on a needs survey. Each state will receive at least 1% of funds. The District of Columbia will receive 1% of funds as well. A state may transfer up to 33% of the grant to the Clean Water Act (CWA) SRF, or an equivalent amount from the CWA SRF to the SDWA SRF.

Drinking water SRFs may be used to provide loan and grant assistance for expenditures that the EPA has determined will facilitate compliance or significantly further the Act's health protection objectives. States must make available 15% of their annual allotment for loan assistance to systems that serve 10,000 or fewer persons. States may use up to 30% of their SRF grant to provide grants or forgive loan principle to help economically disadvantaged communities. Also, states may use a portion of funds for technical assistance, source water protection and capacity development programs, and for operator certification.



Other Provisions

Public water systems must notify customers of violations with potential for serious health effects within 24 hours. Systems must also issue to customers annual reports on contaminants detected in their drinking water (Section 1414). Section 1417 requires any pipe, solder, or flux used in the installation or repair of public water systems or of plumbing in residential or nonresidential facilities providing drinking water to be "**lead free**" (as defined in the Act). As of August 1998, it will be unlawful to sell pipes, plumbing fittings or fixtures that are not "**lead free**" or to sell solder or flux that is not lead free (unless it is properly labeled); with the exception of pipes used in manufacturing or industrial processing. P.L. 104-182 sets limits on the amount of lead that may leach from new plumbing fixtures, and allows one year for a voluntary standard to be established before requiring EPA to take regulatory action.

The Administrator has emergency powers to issue orders and commence civil action if a contaminant likely to enter a public drinking water supply system poses a substantial threat to public health and state or local officials have not taken adequate action(Section 1431).

If a chemical necessary for water treatment is not reasonably available, the Administrator can issue a "**certification of need**," in which case the President can order an allocation of the chemical to those needing it (Section 1441).

EPA is provided authority to conduct research, studies, and demonstrations related to the causes, treatment, control, and prevention of diseases resulting from contaminants in water. The Agency is directed to provide technical assistance to the states and municipalities in administering their public water system regulatory responsibilities. The law authorizes annually, \$15 million for technical assistance to small systems and Indian Tribes, and \$25 million for health effects research (Section 1442). P.L. 104-182 authorizes additional appropriations for drinking water research, not to exceed \$26.6 million annually.

The Administrator may make grants to develop and demonstrate new technologies for providing safe drinking water and to investigate health implications involved in the reclamation/reuse of waste waters (Section 1444).

Also, suppliers of water who may be subject to regulation under the Act are required to establish and maintain records, monitor, and provide any information that the Administrator requires to carry out the requirements of the Act (Section 1445).

The Administrator may also enter and inspect the property of water suppliers to enable him/her to carry out the purposes of the Act. Failure to comply with these provisions may result in criminal penalties.

The Act established a National Drinking Water Advisory Council, composed of 15 members (with at least 2 representing rural systems), to advise, consult, and make recommendations to the Administrator on activities and policies derived from the Act (Section 1446).

National Security

Any federal agency having jurisdiction over federally owned and maintained public water systems must comply with all federal, state, and local drinking water requirements, as well as any underground injection control programs (Section 1447). The Act provides for waivers in the interest of national security. Procedures for judicial review are outlined (Section 1448), and provision for citizens' civil actions is made (Section 1449).

Water Quality Key Word

Activated alumina: It is manufactured from aluminum hydroxide by dehydroxylating it in a way that produces a highly porous material; this material can have a surface area significantly over 200 square meters/g. The compound is used as a desiccant (to keep things dry by absorbing water from the air) and as a filter of fluoride, arsenic and selenium in drinking water. It is made of aluminum oxide (alumina; Al_2O_3), the same chemical substance as sapphire and rubies (but without the impurities that give those gems their color). It has a very high surface-area-to-weight ratio. That means it has a lot of very small pores, almost like tunnels, that run throughout it.

Activated carbon: It is also called activated charcoal or activated coal, is a form of carbon that has been processed to make it extremely porous and thus to have a very large surface area available for adsorption or chemical reactions. The word activated in the name is sometimes substituted by active. Due to its high degree of microporosity, just one gram of activated carbon has a surface area of approximately 500 m^2 , as determined typically by nitrogen gas adsorption. Sufficient activation for useful applications may come solely from the high surface area, though further chemical treatment often enhances the adsorbing properties of the material. Activated carbon is usually derived from charcoal.

De-ionized: Water with the ions removed.

Dissolved organic carbon: Dissolved organic carbon (DOC) is a broad classification for organic molecules of varied origin and composition within aquatic systems. The "dissolved" fraction of organic carbon is an operational classification. Many researchers place the dissolved/colloidal cutoff at 0.45 micrometers, but 0.22 micrometers is also typical.

Ethylenediaminetetraacetic acid (EDTA): EDTA is a widely used abbreviation for the chemical compound ethylenediaminetetraacetic acid (and many other names, see table). EDTA refers to the chelating agent with the formula $(\text{HO}_2\text{CCH}_2)_2\text{NCH}_2\text{CH}_2\text{N}(\text{CH}_2\text{CO}_2\text{H})_2$. This amino acid is widely used to sequester di- and trivalent metal ions (Ca^{2+} and Mg^{2+} for example). EDTA binds to metals via four carboxylate and two amine groups. EDTA forms especially strong complexes with Mn(II), Cu(II), Fe(III), Pb (II) and Co(III).

High temperature metals recovery: An improved method and apparatus for recovering metal values from Electric Arc Furnace dust, particularly zinc and iron values, by mixing EAF dust and carbonaceous fines to form a particulate mixture; heating the mixture at a sufficient temperature and for a sufficient time to reduce and release volatile metals and alkali metals in a flue gas; collecting the released metals, and removing the metal values from the process as product.

Microfiltration: A low pressure membrane filtration process that removes suspended solids and colloids generally larger than 0.1 micron diameter.

Nanofiltration: It is a relatively recent membrane process used most often with low total dissolved solids water such as surface water and fresh groundwater, with the purpose of softening (polyvalent cation removal) and removal of disinfection by-product precursors such as natural organic matter and synthetic organic matter.

SDWA Water Quality Chapter 2 Information and MCLs

Radionuclides

Alpha Emitters Certain minerals are radioactive and may emit a form of radiation known as alpha radiation. Some people who drink water containing alpha emitters in excess of EPA standards over many years may have an increased risk of getting cancer.

Beta/photon Emitters Certain minerals are radioactive and may emit forms of radiation known as photons and beta radiation. Some people who drink water containing beta and photon emitters in excess of EPA standards over many years may have an increased risk of getting cancer.

Combined Radium 226/228 Some people who drink water containing radium 226 or 228 in excess of EPA standards over many years may have an increased risk of getting cancer.

Radon gas can dissolve and accumulate in underground water sources, such as wells, and in the air in your home. Breathing radon can cause lung cancer. Drinking water containing radon presents a risk of developing cancer. Radon in air is more dangerous than radon in water.



These are commonly found examples of various water sampling bottles. VOC and THM bottles are in the front. You have to make sure there is absolutely no air inside these tiny bottles. Any air bubble can ruin the sample. There are several ways to get the air out. The best one is slowly overfill the bottle to get a reverse meniscus. Second, is to fill the cap with water before screwing it onto the bottle. The third one is to use a thin copper tube and slowly fill the bottle.

Inorganic Contaminants

Antimony	Cadmium	Cyanide	Nitrite
Asbestos	Chromium	Mercury	Selenium
Barium	Copper	Nitrate	Thallium
Beryllium			

Inorganic Contaminants

Arsenic. Some people who drink water containing arsenic in excess of EPA standards over many years could experience skin damage or problems with their circulatory system, and may have an increased risk of getting cancer.

Fluoride. Many communities add fluoride to their drinking water to promote dental health. Each community makes its own decision about whether or not to add fluoride. The EPA has set an enforceable drinking water standard for fluoride of 4 mg/L (some people who drink water containing fluoride in excess of this level over many years could get bone disease, including pain and tenderness of the bones). The EPA has also set a secondary fluoride standard of 2 mg/L to protect against dental fluorosis.

Dental fluorosis, in its moderate or severe forms, may result in a brown staining and/or pitting of the permanent teeth. This problem occurs only in developing teeth, before they erupt from the gums. Children under nine should not drink water that has more than 2 mg/L of fluoride.

Lead. Typically leaches into water from plumbing in older buildings. Lead pipes and plumbing fittings have been banned since August 1998. Children and pregnant women are most susceptible to lead health risks. For advice on avoiding lead, see the EPA's "**Lead in Your Drinking Water**" fact sheet.

Synthetic Organic Contaminants, including Pesticides & Herbicides

2,4-D	Dibromochloropropane	Hexachlorobenzene
2,4,5-TP (Silvex)	Dinoseb	Hexachlorocyclopentadiene
Acrylamide	Dioxin (2,3,7,8-TCDD)	Lindane
Alachlor	Diquat	Methoxychlor
Atrazine	Endothall	Oxamyl [Vydate]
Benzoapyrene	Endrin	PCBs [Polychlorinated biphenyls]
Carbofuran	Epichlorohydrin	Pentachlorophenol
Chlordane	Ethylene dibromide	Picloram
Dalapon	Glyphosate	Simazine
Di 2-ethylhexyl adipate	Heptachlor	Toxaphene
Di 2-ethylhexyl phthalate	Heptachlor epoxide	

Volatile Organic Contaminants

Benzene	trans-1,2-Dichloroethylene	1,2,4-Trichlorobenzene
Carbon Tetrachloride	Dichloromethane	1,1,1,-Trichloroethane
Chlorobenzene	1,2-Dichloroethane	1,1,2-Trichloroethane
o-Dichlorobenzene	1,2-Dichloropropane	Trichloroethylene
p-Dichlorobenzene	Ethylbenzene	Toluene
1,1-Dichloroethylene	Styrene	Vinyl Chloride
cis-1,2-Dichloroethylene	Tetrachloroethylene	Xylenes

New EPA Water Rules

Arsenic

Arsenic is a chemical that occurs naturally in the earth's crust. When rocks, minerals, and soil erode, they release arsenic into water supplies. When people either drink this water or eat animals and plants that drink it, they are exposed to arsenic. In the U.S., eating and drinking are the most common ways that people are exposed to arsenic, although it can also come from industrial sources. Studies have linked long-term exposure of arsenic in drinking water to a variety of cancers in humans.

To protect human health, an EPA standard limits the amount of arsenic in drinking water. Back in January 2001, the EPA revised the standard from 50 parts per billion (**ppb**), ordering that it fall to 10 ppb back in 2006. After adopting 10ppb as the new standard for arsenic in drinking water, the EPA decided to review the decision to ensure that the final standard was based on sound science and accurate estimates of costs and benefits. In October 2001, the EPA decided to move forward with implementing the 10ppb standard for arsenic in drinking water.

More information on the rulemaking process and the costs and benefits of setting the arsenic limit in drinking water at 10ppb can be found at www.epa.gov/safewater/arsenic.html or in the Water Quality Chapter in the Arsenic information section.

ICR Information Collection Rule

The EPA has collected data required by the Information Collection Rule (**ICR**) to support future regulation of microbial contaminants, disinfectants, and disinfection byproducts. The rule is intended to provide the EPA with information on chemical byproducts that form when disinfectants used for microbial control react with chemicals already present in source water (disinfection byproducts (**DBPs**)); disease-causing microorganisms (pathogens), including *Cryptosporidium*; and engineering data to control these contaminants.

Drinking water microbial and disinfection byproduct information collected for the ICR is now available in the EPA's **Envirofacts Warehouse**.



Gas Chromatograph

Disinfection Byproduct Regulations

In December 1998, the EPA established the Stage 1 Disinfectants/Disinfection Byproducts Rule that requires public water systems to use treatment measures to reduce the formation of disinfection byproducts and to meet the following specific standards:

Total trihalomethanes (TTHM)	80 parts per billion (ppb)
Haloacetic acids (HAA5)	60 ppb
Bromate	10 ppb
Chlorite	1.0 parts per million (ppm)

Currently trihalomethanes are regulated at a maximum allowable annual average level of 100 parts per billion for water systems serving over 10,000 people under the Total Trihalomethane Rule finalized by the EPA in 1979. The Stage 1 Disinfectant/Disinfection Byproduct Rule standards became effective for trihalomethanes and other disinfection byproducts listed above in December 2001 for large surface water public water systems. These new standards became effective in December 2003 for small surface water and all ground water public water systems.

Disinfection byproducts are formed when disinfectants used in water treatment plants react with bromide and/or natural organic matter (i.e., decaying vegetation) present in the source water. Different disinfectants produce different types or amounts of disinfection byproducts. Disinfection byproducts for which regulations have been established have been identified in drinking water, including trihalomethanes, haloacetic acids, bromate, and chlorite.

Trihalomethanes (THM) are a group of four chemicals that are formed along with other disinfection byproducts when chlorine or other disinfectants used to control microbial contaminants in drinking water react with naturally occurring organic and inorganic matter in water. The trihalomethanes are chloroform, bromodichloromethane, dibromochloromethane, and bromoform. The EPA has published the **Stage 1 Disinfectants/Disinfection Byproducts Rule** to regulate total trihalomethanes (**TTHM**) at a maximum allowable annual average level of **80 parts per billion**.

Haloacetic Acids (HAA5) are a group of chemicals that are formed along with other disinfection byproducts when chlorine or other disinfectants used to control microbial contaminants in drinking water react with naturally occurring organic and inorganic matter in water. The regulated haloacetic acids, known as HAA5, are: monochloroacetic acid, dichloroacetic acid, trichloroacetic acid, monobromoacetic acid, and dibromoacetic acid. The EPA has published the **Stage 1 Disinfectants/Disinfection Byproducts Rule** to regulate HAA5 at **60 parts per billion** annual average.

Bromate is a chemical that is formed when ozone used to disinfect drinking water reacts with naturally occurring bromide found in source water. The EPA has established the **Stage 1 Disinfectants/**

Disinfection Byproducts Rule to regulate bromate at annual average of **10 parts per billion** in drinking water.

Chlorite is a byproduct formed when chlorine dioxide is used to disinfect water. The EPA has published the **Stage 1 Disinfectants/Disinfection Byproducts Rule** to regulate chlorite at a monthly average level of **1 part per million** in drinking water.

Microbial Regulations

One of the key regulations developed and implemented by the United States Environmental Protection Agency (**USEPA**) to counter pathogens in drinking water is the **Surface Water Treatment Rule**. Among its provisions, the rule requires that a public water system, using surface water (or ground water under the direct influence of surface water) as its source, have sufficient treatment to reduce the source water concentration of **Giardia** and viruses by at least 99.9% and 99.99%, respectively.

The Surface Water Treatment Rule specifies treatment criteria to assure that these performance requirements are met; they include turbidity limits, disinfectant residual, and disinfectant contact time conditions.

The **Interim Enhanced Surface Water Treatment Rule** was established in December 1998 to control **Cryptosporidium**, and to maintain control of pathogens while systems lower disinfection byproduct levels to comply with the **Stage 1 Disinfectants/Disinfection Byproducts Rule**. The EPA established a Maximum Contaminant Level Goal (**MCLG**) of zero for all public water systems and a 99% removal requirement for **Cryptosporidium** in filtered public water systems that serve at least 10,000 people.

The new rule tightened turbidity standards back in December 2001. Turbidity is an indicator of the physical removal of particulates, including pathogens.

The EPA is also planning to develop other rules to further control pathogens. The EPA has promulgated a Long Term 1 Enhanced Surface Water Treatment Rule, for systems serving fewer than 10,000 people, to improve physical removal of **Cryptosporidium**, and to maintain control of pathogens while systems comply with **Stage 1 Disinfectants/Disinfection Byproducts Rule**.





Here is one of TLC's professors Marcos Aparecido Silva Bueno showing microscopic views of commonly found MO's in a classroom setting. Professor Marcos Aparecido Silva Bueno is a world renowned microbiological expert.



National Primary Drinking Water Regulations

Inorganic Chemicals	MCLG ¹ (mg/L) ⁴	MCL ² or TT ³ (mg/L) ⁴	Potential Health Effects from Ingestion of Water	Sources of Contaminant in Drinking Water
Antimony	0.006	0.006	Increase in blood cholesterol; decrease in blood glucose	Discharge from petroleum refineries; fire retardants; ceramics; electronics; solder
Arsenic	none ⁵	0.010	Skin damage; circulatory system problems; increased risk of cancer	Discharge from semiconductor manufacturing; petroleum refining; wood preservatives; animal feed additives; herbicides; erosion of natural deposits
Asbestos (fiber >10 micrometers)	7 million fibers per Liter	7 MFL	Increased risk of developing benign intestinal polyps	Decay of asbestos cement in water mains; erosion of natural deposits
Barium	2	2	Increase in blood pressure	Discharge of drilling wastes; discharge from metal refineries; erosion of natural deposits
Beryllium	0.004	0.004	Intestinal lesions	Discharge from metal refineries and coal-burning factories; discharge from electrical, aerospace, and defense industries
Cadmium	0.005	0.005	Kidney damage	Corrosion of galvanized pipes; erosion of natural deposits; discharge from metal refineries; runoff from waste batteries and paints
Chromium (total)	0.1	0.1	Some people who use water containing chromium well in excess of the MCL over many years could experience allergic dermatitis	Discharge from steel and pulp mills; erosion of natural deposits
Copper	1.3	Action Level=1.3; TT ⁶	Short term exposure: Gastrointestinal distress. Long term exposure: Liver or kidney damage. Those with Wilson's Disease should consult their personal doctor if their water systems exceed the copper action level.	Corrosion of household plumbing systems; erosion of natural deposits; leaching from wood preservatives
Cyanide (as free cyanide)	0.2	0.2	Nerve damage or thyroid problems	Discharge from steel/metal factories; discharge from plastic and fertilizer factories
Fluoride	4.0	4.0	Bone disease (pain and tenderness of the bones); Children may get mottled teeth.	Water additive which promotes strong teeth; erosion of natural deposits; discharge from fertilizer and aluminum factories
Lead	zero	Action Level=0.015; TT ⁶	Infants and children: Delays in physical or mental development. Adults: Kidney problems; high blood pressure	Corrosion of household plumbing systems; erosion of natural deposits

Inorganic Mercury	0.002	0.002	Kidney damage	Erosion of natural deposits; discharge from refineries and factories; runoff from landfills and cropland
Nitrate (measured as Nitrogen)	10	10	"Blue baby syndrome" in infants under six months - life threatening without immediate medical attention. Symptoms: Infant looks blue and has shortness of breath.	Runoff from fertilizer use; leaching from septic tanks, sewage; erosion of natural deposits
Nitrite (measured as Nitrogen)	1	1	"Blue baby syndrome" in infants under six months - life threatening without immediate medical attention. Symptoms: Infant looks blue and has shortness of breath.	Runoff from fertilizer use; leaching from septic tanks, sewage; erosion of natural deposits
Selenium	0.05	0.05	Hair or fingernail loss; numbness in fingers or toes; circulatory problems	Discharge from petroleum refineries; erosion of natural deposits; discharge from mines
Thallium	0.0005	0.002	Hair loss; changes in blood; kidney, intestine, or liver problems	Leaching from ore-processing sites; discharge from electronics, glass, and pharmaceutical companies



1-ton chlorine gas container with an automatic leak detection and shut-off device.

Organic Chemicals	MCLG¹ (mg/L)₄	MCL² or TT³ (mg/L)₄	Potential Health Effects from Ingestion of Water	Sources of Contaminant in Drinking Water
Acrylamide	zero	TT ⁴	Nervous system or blood problems; increased risk of cancer	Added to water during sewage/wastewater treatment
Alachlor	zero	0.002	Eye, liver, kidney or spleen problems; anemia; increased risk of cancer	Runoff from herbicide used on row crops
Atrazine	0.003	0.003	Cardiovascular system problems; reproductive difficulties	Runoff from herbicide used on row crops
Benzene	zero	0.005	Anemia; decrease in blood platelets; increased risk of cancer	Discharge from factories; leaching from gas storage tanks and landfills
Benzo(a)pyrene	zero	0.0002	Reproductive difficulties; increased risk of cancer	Leaching from linings of water storage tanks and distribution lines
Carbofuran	0.04	0.04	Problems with blood or nervous system; reproductive difficulties.	Leaching of soil fumigant used on rice and alfalfa
Carbon tetrachloride	zero	.005	Liver problems; increased risk of cancer	Discharge from chemical plants and other industrial activities
Chlordane	zero	0.002	Liver or nervous system problems; increased risk of cancer	Residue of banned termiticide
Chlorobenzene	0.1	0.1	Liver or kidney problems	Discharge from chemical and agricultural chemical factories
2,4-D	0.07	0.07	Kidney, liver, or adrenal gland problems	Runoff from herbicide used on row crops
Dalapon	0.2	0.2	Minor kidney changes	Runoff from herbicide used on rights of way
1,2-Dibromo-3-chloropropane (DBCP)	zero	0.0002	Reproductive difficulties; increased risk of cancer	Runoff/leaching from soil fumigant used on soybeans, cotton, pineapples, and orchards
o-Dichlorobenzene	0.6	0.6	Liver, kidney, or circulatory system problems	Discharge from industrial chemical factories
p-Dichlorobenzene	0.075	0.075	Anemia; liver, kidney or spleen damage; changes in blood	Discharge from industrial chemical factories
1,2-Dichloroethane	zero	0.005	Increased risk of cancer	Discharge from industrial chemical factories
1-1-Dichloroethylene	0.007	0.007	Liver problems	Discharge from industrial chemical factories
cis-1, 2-Dichloroethylene	0.07	0.07	Liver problems	Discharge from industrial chemical factories
trans-1,2-Dichloroethylene	0.1	0.1	Liver problems	Discharge from industrial chemical factories
Dichloromethane	zero	0.005	Liver problems; increased risk of cancer	Discharge from pharmaceutical and chemical factories
1-2-Dichloropropane	zero	0.005	Increased risk of cancer	Discharge from industrial chemical factories
Di(2-ethylhexyl)adipate	0.4	0.4	General toxic effects or reproductive difficulties	Leaching from PVC plumbing systems; discharge from chemical factories
Di(2-ethylhexyl)phthalate	zero	0.006	Reproductive difficulties; liver problems; increased risk of cancer	Discharge from rubber and chemical factories
Dinoseb	0.007	0.007	Reproductive difficulties	Runoff from herbicide used on soybeans and vegetables

Dioxin (2,3,7,8-TCDD)	zero	0.0000003	Reproductive difficulties; increased risk of cancer	Emissions from waste incineration and other combustion; discharge from chemical factories
Diquat	0.02	0.02	Cataracts	Runoff from herbicide use
Endothall	0.1	0.1	Stomach and intestinal problems	Runoff from herbicide use
Endrin	0.002	0.002	Nervous system effects	Residue of banned insecticide
Epichlorohydrin	zero	TT ⁷	Stomach problems; reproductive difficulties; increased risk of cancer	Discharge from industrial chemical factories; added to water during treatment process
Ethylbenzene	0.7	0.7	Liver or kidney problems	Discharge from petroleum refineries
Ethelyne dibromide	zero	0.00005	Stomach problems; reproductive difficulties; increased risk of cancer	Discharge from petroleum refineries
Glyphosate	0.7	0.7	Kidney problems; reproductive difficulties	Runoff from herbicide use
Heptachlor	zero	0.0004	Liver damage; increased risk of cancer	Residue of banned termiticide
Heptachlor epoxide	zero	0.0002	Liver damage; increased risk of cancer	Breakdown of hepatachlor
Hexachlorobenzene	zero	0.001	Liver or kidney problems; reproductive difficulties; increased risk of cancer	Discharge from metal refineries and agricultural chemical factories
Hexachlorocyclopentadiene	0.05	0.05	Kidney or stomach problems	Discharge from chemical factories
Lindane	0.0002	0.0002	Liver or kidney problems	Runoff/leaching from insecticide used on cattle, lumber, gardens
Methoxychlor	0.04	0.04	Reproductive difficulties	Runoff/leaching from insecticide used on fruits, vegetables, alfalfa, livestock
Oxamyl (Vydate)	0.2	0.2	Slight nervous system effects	Runoff/leaching from insecticide used on apples, potatoes, and tomatoes
Polychlorinated biphenyls (PCBs)	zero	0.0005	Skin changes; thymus gland problems; immune deficiencies; reproductive or nervous system difficulties; increased risk of cancer	Runoff from landfills; discharge of waste chemicals
Pentachlorophenol	zero	0.001	Liver or kidney problems; increased risk of cancer	Discharge from wood preserving factories
Picloram	0.5	0.5	Liver problems	Herbicide runoff
Simazine	0.004	0.004	Problems with blood	Herbicide runoff
Styrene	0.1	0.1	Liver, kidney, and circulatory problems	Discharge from rubber and plastic factories; leaching from landfills
Tetrachloroethylene	zero	0.005	Liver problems; increased risk of cancer	Discharge from factories and dry cleaners
Toluene	1	1	Nervous system, kidney, or liver problems	Discharge from petroleum factories
Total Trihalomethanes (TTHMs)	none ⁵	0.10	Liver, kidney or central nervous system problems; increased risk of cancer	Byproduct of drinking water disinfection
Toxaphene	zero	0.003	Kidney, liver, or thyroid problems; increased risk of cancer	Runoff/leaching from insecticide used on cotton and cattle
2,4,5-TP (Silvex)	0.05	0.05	Liver problems	Residue of banned herbicide
1,2,4-Trichlorobenzene	0.07	0.07	Changes in adrenal glands	Discharge from textile finishing factories

1,1,1-Trichloroethane	0.20	0.2	Liver, nervous system, or circulatory problems	Discharge from metal degreasing sites and other factories
1,1,2-Trichloroethane	0.003	0.005	Liver, kidney, or immune system problems	Discharge from industrial chemical factories
Trichloroethylene	zero	0.005	Liver problems; increased risk of cancer	Discharge from petroleum refineries
Vinyl chloride	zero	0.002	Increased risk of cancer	Leaching from PVC pipes; discharge from plastic factories
Xylenes (total)	10	10	Nervous system damage	Discharge from petroleum factories; discharge from chemical factories

Radionuclides	MCLG ¹ (mg/L) ₄	MCL ² or TT ³ (mg/L) ₄	Potential Health Effects from Ingestion of Water	Sources of Contaminant in Drinking Water
Beta particles and photon emitters	none ⁵	4 millirems per year	Increased risk of cancer	Decay of natural and man-made deposits
Gross alpha particle activity	none ⁵	15 picocuries per Liter (pCi/L)	Increased risk of cancer	Erosion of natural deposits
Radium 226 and Radium 228 (combined)	none ⁵	5 pCi/L	Increased risk of cancer	Erosion of natural deposits

Microorganisms	MCLG ¹ (mg/L) ₄	MCL ² or TT ³ (mg/L) ₄	Potential Health Effects from Ingestion of Water	Sources of Contaminant in Drinking Water
<i>Giardia lamblia</i>	zero	TT ⁸	Giardiasis, a gastroenteric disease	Human and animal fecal waste
Heterotrophic plate count	N/A	TT ⁸	HPC has no health effects, but can indicate how effective treatment is at controlling microorganisms.	n/a
<i>Legionella</i>	zero	TT ⁸	Legionnaire's Disease, commonly known as pneumonia	Found naturally in water; multiplies in heating systems
Total Coliforms (including fecal coliform and <i>E. Coli</i>)	zero	5.0% ⁹	Used as an indicator that other potentially harmful bacteria may be present ¹⁰	Human and animal fecal waste
Turbidity	N/A	TT ⁸	Turbidity has no health effects but can interfere with disinfection and provide a medium for microbial growth. It may indicate the presence of microbes.	Soil runoff
Viruses (enteric)	zero	TT ⁸	Gastroenteric disease	Human and animal fecal waste

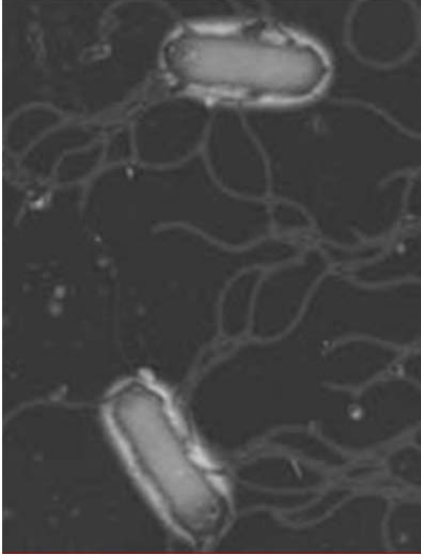

E. coli HO-157



Legionella



Cryptosporidium

Unbelievably, I've met lab personnel who couldn't tell these 3 bugs apart.

National Secondary Drinking Water Regulations

National Secondary Drinking Water Regulations (NSDWRs or secondary standards are non-enforceable guidelines regulating contaminants that may cause cosmetic effects (such as skin or tooth discoloration) or aesthetic effects (such as taste, odor, or color) in drinking water.

The EPA recommends secondary standards to water systems but does not require systems to comply. However, states may choose to adopt them as enforceable standards.

Contaminant	Secondary Standard
Aluminum	0.05 to 0.2 mg/L
Chloride	250 mg/L
Color	15 (color units)
Copper	1.0 mg/L
Corrosivity	noncorrosive
Fluoride	2.0 mg/L
Foaming Agents	0.5 mg/L
Iron	0.3 mg/L
Manganese	0.05 mg/L
Odor	3 threshold odor number
pH	6.5-8.5
Silver	0.10 mg/L
Sulfate	250 mg/L
Total Dissolved Solids	500 mg/L
Zinc	5 mg/L

Notes

¹ Maximum Contaminant Level Goal (**MCLG**) - The maximum level of a contaminant in drinking water at which no known or anticipated adverse effect on the health effect of persons would occur, and which allows for an proper margin of safety. MCLGs are non-enforceable public health goals.

² Maximum Contaminant Level (**MCL**) - The maximum permissible level of a contaminant in water which is delivered to any user of a public water system. MCLs are enforceable standards. The margins of safety in MCLGs ensure that exceeding the MCL slightly does not pose significant risk to public health.

³ Treatment Technique - An enforceable procedure or level of technical performance which public water systems must follow to ensure control of a contaminant.

⁴ Units are in milligrams per Liter (mg/L) unless otherwise noted.

⁵ MCLGs were not established before the 1986 Amendments to the Safe Drinking Water Act. Therefore, there is no MCLG for this contaminant.

⁶ Lead and copper are regulated in a Treatment Technique which requires systems to take tap water samples at sites with lead pipes or copper pipes that have lead solder and/or are served by lead service lines. The action level, which triggers water systems into taking treatment steps, if exceeded in more than 10% of tap water samples, for copper is 1.3 mg/L, and for lead is 0.015mg/L.

⁷ Each water system must certify, in writing, to the state (using third-party or manufacturer's certification) that when acrylamide and epichlorohydrin are used in drinking water systems, the combination (or product) of dose and monomer level does not exceed the levels specified, as follows:

- **Acrylamide** = 0.05% dosed at 1 mg/L (or equivalent)
- **Epichlorohydrin** = 0.01% dosed at 20 mg/L (or equivalent)

⁸ The Surface Water Treatment Rule requires systems using surface water or ground water under the direct influence of surface water to (1) disinfect their water, and (2) filter their water or meet criteria for avoiding filtration so that the following contaminants are controlled at the following levels:

- **Giardia lamblia**: 99.9% killed/inactivated
Viruses: 99.99% killed/inactivated
- **Legionella**: No limit, but EPA believes that if **Giardia** and viruses are inactivated, **Legionella** will also be controlled.
- **Turbidity**: At no time can turbidity (**cloudiness of water**) go above 5 nephelometric turbidity units (NTU); systems that filter must ensure that the turbidity go no higher than 1 NTU (0.5 NTU for conventional or direct filtration) in at least 95% of the daily samples in any month.
- **HPC**: NO more than 500 bacterial colonies per milliliter.

⁹ No more than 5.0% samples total coliform-positive in a month. (For water systems that collect fewer than 40 routine samples per month, no more than one sample can be total coliform-positive). Every sample that has total coliforms must be analyzed for fecal coliforms. There cannot be any fecal coliforms.

¹⁰ Fecal coliform and *E. coli* are bacteria whose presence indicates that the water may be contaminated with human animal wastes. Microbes in these wastes can cause diarrhea, cramps, nausea, headaches, or other symptoms.

Water Treatment Section Chapter 3

For thousands of years, people have treated water intended for drinking to remove particles of solid matter, reduce health risks, and improve aesthetic qualities such as appearance, odor, color, and taste. As early as 2000 B.C., medical lore of India advised, ***“Impure water should be purified by being boiled over a fire, or being heated in the sun or by dipping a heated iron into it, or it may be purified by filtration through sand and coarse gravel and then allowed to cool.”***

The treatment needs of a water system are likely to differ depending on whether the system uses a groundwater or surface water source. Common surface water contaminants include turbidity, microbiological contaminants (***Giardia, viruses and bacteria***) and low levels of a large number of organic chemicals. Groundwater contaminants include naturally occurring inorganic chemicals (such as arsenic, fluoride, radium, radon and nitrate) and a number of volatile organic chemicals (***VOCs***) that have recently been detected in localized areas.

When selecting among the different treatment options, the water supplier must consider a number of factors. These include regulatory requirements, characteristics of the raw water, configuration of the existing system, cost, operating requirements and future needs of the service area.



Here is a surface water conventional treatment facility next to a river.



Top Photograph - Final Rectangle Sedimentation Basin
Bottom - Clarifier



Preliminary Treatment

Most lakes and reservoirs are not free of logs, tree limbs, sticks, gravel, sand and rocks, weeds, leaves, and trash. If not removed, these will cause problems to the treatment plant's pumps and equipment. The best way to protect the plant is screening.

Bar screens are made of straight steel bars at the intake of the plant. The spacing of the horizontal bars will rank the size. Wire mesh screens are woven stainless steel material and the opening of the fabric is narrow. Both require manual cleaning.

Mechanical bar screens vary in size and use some type of raking mechanism that travels horizontally down the bars to scrap the debris off. The type of screening used depends on the raw water and the size of the intake.



Mechanical bar screen, above photograph.
Non-automated bar screen, below.



Pre-Sedimentation

Once the water passes the bar screens, sand and grit are still present. This will damage plant equipment and pipes, so it must be removed. This is generally done with either rectangular- or round-shaped clarifiers. Sedimentation basins are also used after the flocculation process.



Let's first look at the components of a rectangular clarifier. Most are designed with scrapers on the bottom to move the settled sludge to one or more hoppers at the influent end of the tank. It could have a screw conveyor or traveling bridge used to collect the sludge. The most common is a chain and flight collector. Most designs will have baffles to prevent short circuiting and scum from entering the effluent.

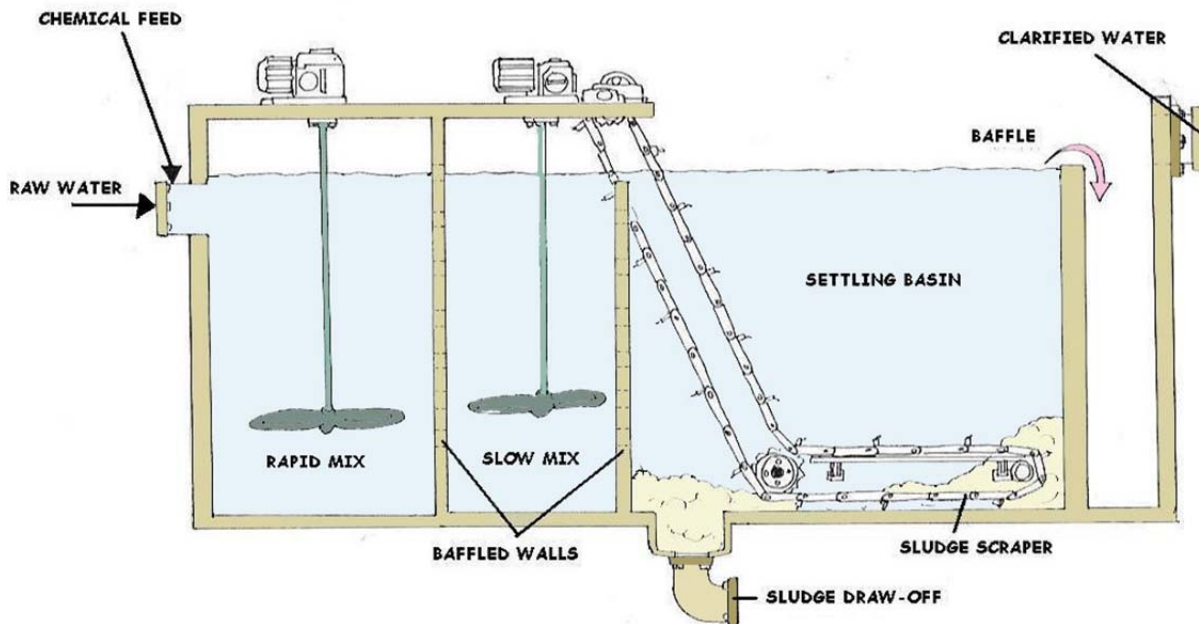

HORIZONTAL BASIN CLARIFIER

Flights and Chains

The most important thing to consider is the sludge and scum collection mechanism known as the “**flights and chains**”. They move the settled sludge to the hopper in the clarifier for return and they also remove the scum from the surface of the clarifier. The flights are usually wood or nonmetallic flights mounted on parallel chains. The motor shaft is connected through a gear reducer to a shaft which turns the drive chain. The drive chain turns the drive sprockets and the head shafts. The shafts can be located overhead or below.

Some clarifiers may not have scum removal equipment, so the configuration of the shaft may vary. As the flights travel across the bottom of the clarifier, wearing shoes are used to protect the flights. The shoes are usually metal and travel across a metal track.

To prevent damage due to overloads, a shear pin is used. The shear pin holds the gear solidly on the shaft so that no slippage occurs. Remember, the gear moves the drive chain. If a heavy load is put on the sludge collector system then the shear pin should break. This means that the gear would simply slide around the shaft and movement of the drive chain would stop.

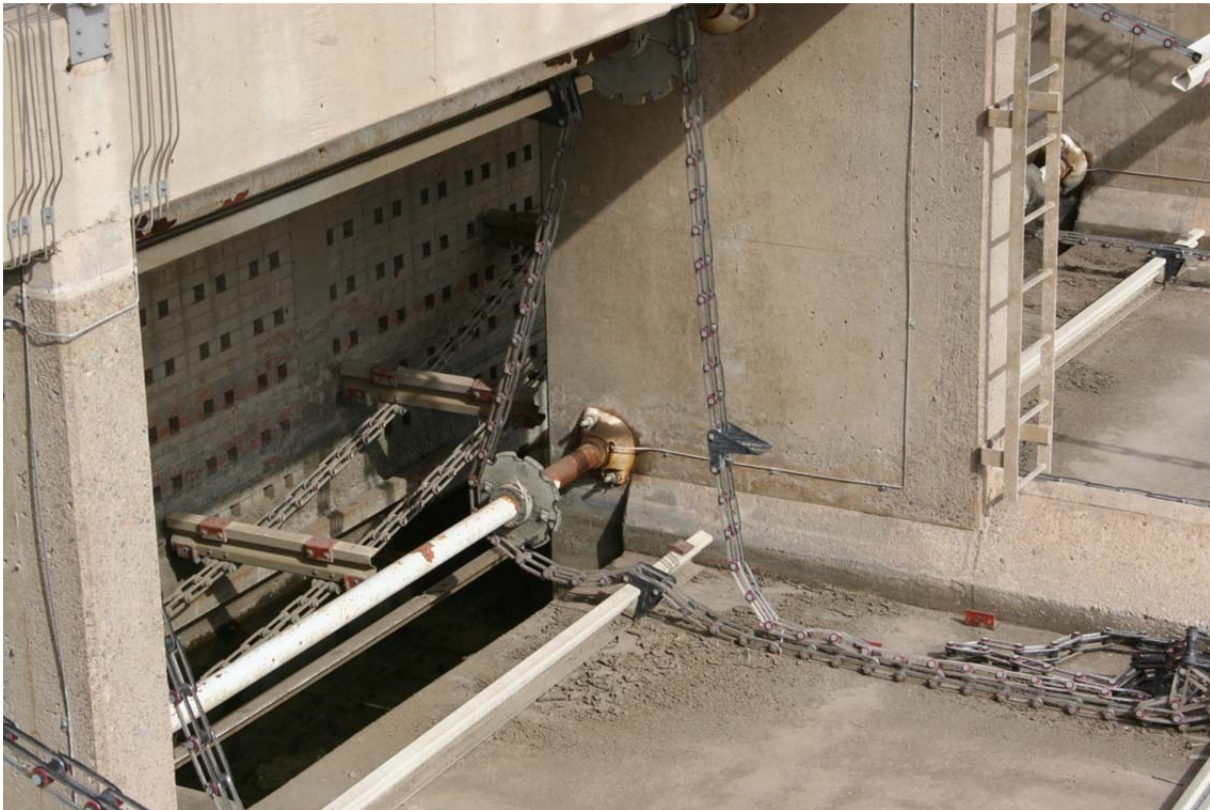

Rectangular basin flights and chains.

Circular Clarifiers

In some circular or square tanks, rotating scrapers are used. The diagram below shows a typical circular clarifier. The most common type has a center pier or column. The major mechanic parts of the clarifier are the drive unit; the sludge collector mechanism, and the scum removal system.

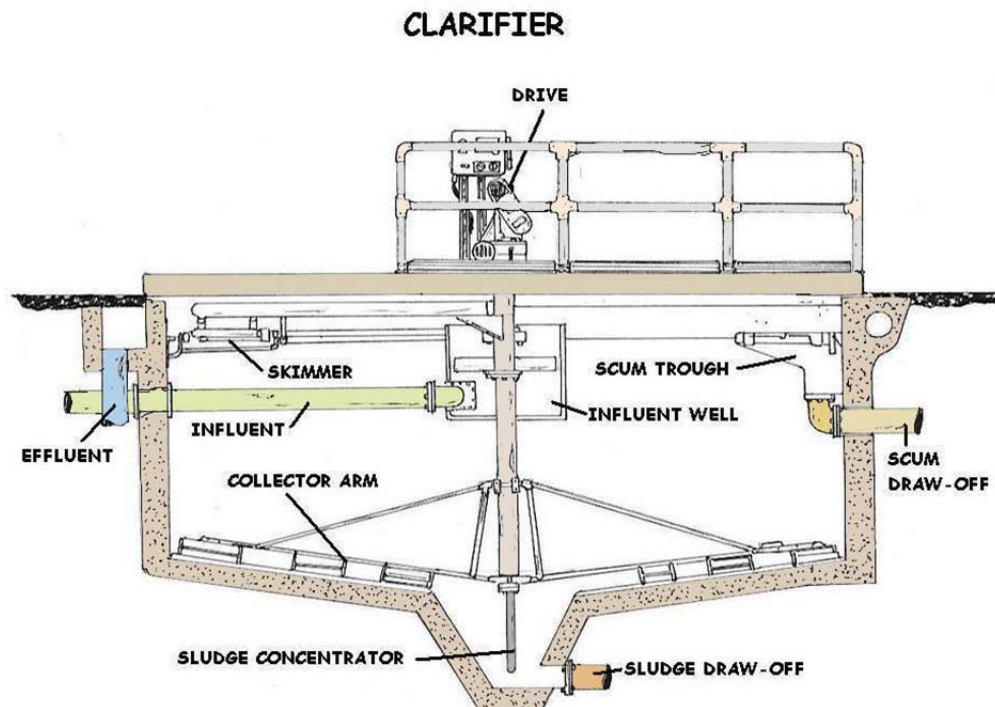

Circular clarifier and collector mechanism.

Pre-Treatment

Once the water passes the bar screens, sand and grit are still present. This will damage plant equipment and pipes, so it must be removed. This is generally done with either rectangular or round shaped clarifiers. Sedimentation basins are also used after the flocculation process.



Clarifiers

Let's first look at the components of a rectangular clarifier. Most are designed with scrapers on the bottom to move the settled sludge to one or more hoppers at the influent end of the tank. It could have a screw conveyor or traveling bridge used to collect the sludge. The most common is a chain and flight collector. Most designs will have baffles to prevent short-circuiting and scum from entering the effluent.

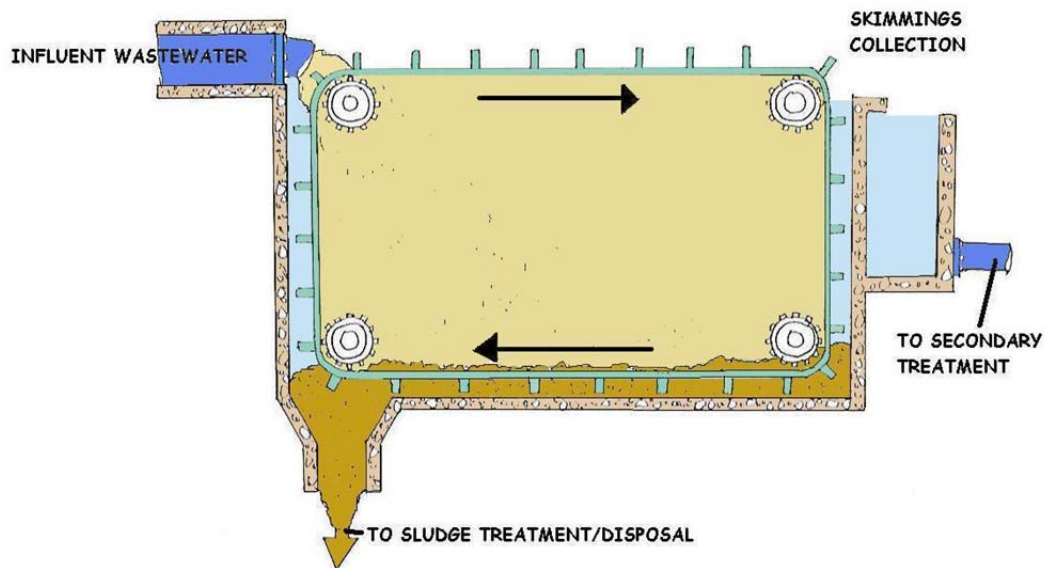

Direct Filtration Plant vs. Conventional Plant

The only difference is that the sedimentation process or step is omitted from the Direct Filtration plant.



Tours of your facility are a wonderful public image tool. I know that many facilities are worried about the public and what could possibly happen, but if you can think positive, you may find more support and funding for your future projects.

Conventional Treatment Overview & Direct Filtration

Improving the clarity of surface water has always presented a challenge because source quality varies. Traditional treatments rely on expensive, construction-intensive processes with lengthy times.

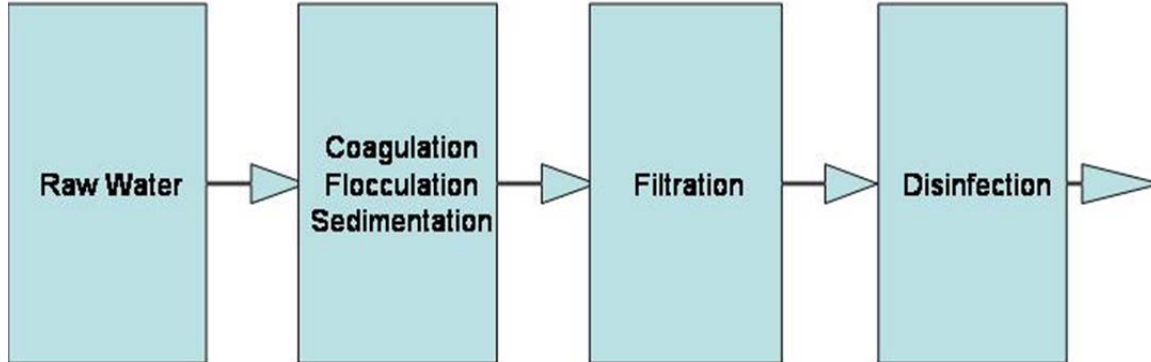

Suspended particles carry an electrical charge which causes them to repel one another. The conventional process uses alum (aluminum sulfate) and cationic polymer to neutralize the charge. That allows suspended particles to clump together to form more easily filtered particles.

Alum combines with alkalinity in the raw water to form a white precipitate that neutralizes suspended particles' electrical charge and forms a base for coagulating those particles. Conventional technology uses a 30 to 50 mg/L alum dosage to form a large **floc** that requires extensive retention time to permit settling. Traditional filter systems use graded silica sand filter media. Since the sand grains all have about the same density, larger grains lay toward the bottom of the filter bed and finer grains lay at the top of the filter bed. As a result, filtration occurs only within the first few inches of the finer grains at the top of the bed.

A depth filter has four layers of filtration media, each of different size and density. Light, coarse material lies at the top of the filter bed. The media become progressively finer and denser in the lower layers. Larger suspended particles are removed by the upper layers while smaller particles are removed in the lower layers. Particles are trapped throughout the bed, not in just the top few inches. That allows a depth filter to run substantially longer and use less backwash water than a traditional sand filter.

As suspended particles accumulate in a filter bed, the pressure drop through the filter increases. When the pressure difference between filter inlet and outlet increases by 5 - 10 psi (34 to 68 kPa) from the beginning of the cycle, the filter should be reconditioned. Operating beyond this pressure drop increases the chance of fouling - called "**mud-balling**" - within the filter.

The reconditioning cycle consists of an up-flow backwash followed by a down-flow rinse. Backwash is an up-flow operation, at about 14 gpm per square foot (34m/hr) of filter bed area that lasts about 10 minutes. Turbidity washes out of the filter bed as the filter media particles scour one another. The down-flow rinse settles the bed before the filter returns to service. Fast rinse lasts about 5 to 10 minutes.

Chemical pretreatment is often used to enhance filter performance, particularly when turbidity includes fine colloidal particles. Suspended particles are usually electrically charged. Feeding chemicals such as alum (aluminum sulfate), ferric chloride, or a cationic polymer neutralizes the charge, allowing the particles to cling to one another and to the filter media.

Chemical pretreatment may increase filtered water clarity, measured in NTU, by 90% compared with filtration alone. If an operator is present to make adjustments for variations in the raw water, filtered water clarity improvements in the range of 93 to 95% are achievable.

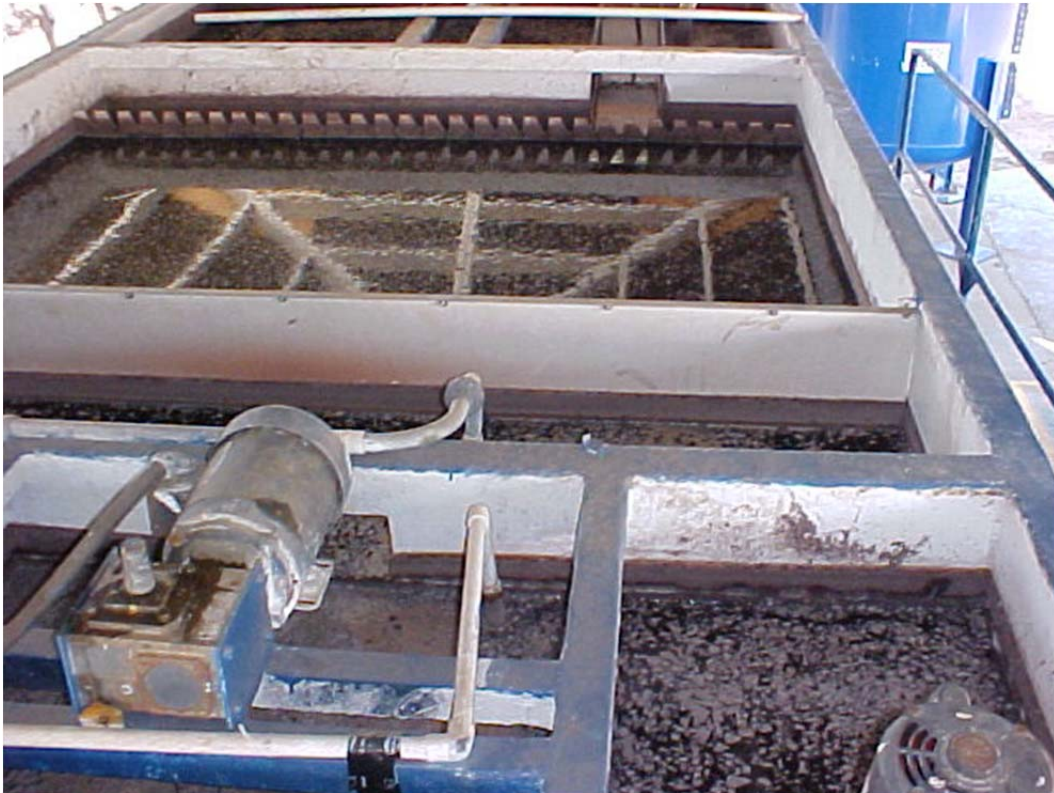

Example of a small water treatment package plant coagulation, flocculation and filtration all within a 20 foot area.

Package Plants

Representing a slight modification of conventional filtration technology, package plants are usually built in a factory, mounted on skids, and transported virtually assembled to the operation site.

These are appropriate for small community systems where full water treatment is desired, but without the construction costs and space requirements associated with separately constructed sedimentation basins, filter beds, clear wells, etc.

In addition to the conventional filtration processes, package plants are found as two types: tube-type clarifiers and adsorption clarifiers.

Rapid Sand Filtration

Also known as rapid-sand filtration, this is the most prevalent form of water treatment technology in use today. This filtration process employs a combination of physical and chemical processes in order to achieve maximum effectiveness, as follows:

Coagulation

At the Water Treatment Plant, aluminum sulfate, commonly called alum, is added to the water in the "**flash mix**" to cause microscopic impurities in the water to clump together. The alum and the water are mixed rapidly by the flash mixer. The resulting larger particles will be removed by filtration.

Coagulation is the process of joining together particles in water to help remove organic matter. When solid matter is too small to be removed by a depth filter, the fine particles must be coagulated, or "**stuck together**" to form larger particles which can be filtered. This is achieved through the use of coagulant chemicals.

Coagulant chemicals are required since colloidal particles by themselves have the tendency to stay suspended in water and not settle out. This is primarily due to a negative charge on the surface of the particles. All matter has a residual surface charge to a certain degree. But since colloidal particles are so small, their charge per volume is significant. Therefore, the like charges on the particles repel each other, and they stay suspended in water.

Coagulant chemicals such as "**alum**" (aluminum Sulfate) work by neutralizing the negative charge, which allows the particles to come together. Other coagulants are called "**cationic polymers**", which can be thought of as positively charged strings that attract the particles to them, and in the process, form a larger particle. Also, new chemicals have been developed which combine the properties of alum-type coagulants and cationic polymers. Which chemical is used depends on the application, and will usually be chosen by the engineer designing the water treatment system.

Aluminum Sulfate is the most widely used coagulant in water treatment. Coagulation is necessary to meet the current regulations for almost all potable water plants using surface water. Aluminum Sulfate is also excellent for removing nutrients such as phosphorous in wastewater treatment. Liquid Aluminum Sulfate is a 48.86% solution.

Large microorganisms, including algae and amoebic cysts, are readily removed by coagulation and filtration. Bacterial removals of 99% are also achievable. More than 98% of poliovirus type 1 was removed by conventional coagulation and filtration. Several recent studies have shown that bacterial and viral agents are attached to organic and inorganic particulates. Hence, removal of these particulates by conventional coagulation and filtration is a major component of effective treatment for the removal of pathogens.

Flocculation

The process of bringing together destabilized or coagulated particles to form larger masses which can be settled and/or filtered out of the water being treated. In this process, which follows the rapid mixing, the chemically treated water is sent into a basin where the suspended particles can collide, agglomerate (stick together), and form heavier particles called "**floc**". Gentle agitation of the water and appropriate detention times (the length of time water remains in the basin) help facilitate this process.

The water is slowly mixed in contact chambers allowing the coagulated particles, now called "floc," to become larger and stronger. As these floc particles mix in the water, bacteria and other microorganisms are caught in the floc structure.

Pre-Sedimentation

Depending on the quality of the source water, some plants have pre-sedimentation.

- A. To allow larger particles time to settle in a reservoir or lake (sand, heavy silt) reducing solid removal loads.
- B. Provides an equalization basin which evens out fluctuations.

Sedimentation Basin Zones

- A. Inlet Zone
- B. Settling Zone
- C. Sludge Zone
- D. Outlet Zone

Shapes for a Sedimentation Basin

- A. Rectangular Basins
- B. Circular Basins
- C. Square Basins
- D. Double deck Basins



Sedimentation

The process of suspended solid particles settling out (going to the bottom of the vessel) in water.

Following flocculation, a sedimentation step may be used. During sedimentation, the velocity of the water is decreased so that the suspended material, including flocculated particles, can settle out by gravity. Once settled, the particles combine to form a sludge that is later removed from the bottom of the basin.

Filtration

A water treatment step used to remove turbidity, dissolved organics, odor, taste and color. The water flows by gravity through large filters of anthracite coal, silica sand, garnet and gravel. The floc particles are removed in these filters. The rate of filtration can be adjusted to meet water consumption needs. Filters for suspended particle removal can also be made of graded sand, granular synthetic material, screens of various materials, and fabrics.

The most widely used are rapid-sand filters in tanks. In these units, gravity holds the material in place and the flow is downward. The filter is periodically cleaned by a reversal of flow and the discharge of back-flushed water into a drain.

Cartridge filters made of fabric, paper, or plastic material are also common and are often much smaller and cheaper, as well as disposable. Filters are available in several ratings, depending on the size of particles to be removed. Activated carbon filters, described earlier, will also remove turbidity, but would not be recommended for that purpose only.



With most of the larger particles settled out, the water now goes to the filtration process. At a rate of between 2 and 10 gpm per square foot, the water is filtered through an approximate 36" depth of graded sand. Anthracite coal or activated carbon may also be included in the sand to improve the filtration process, especially for the removal of organic contaminants and taste and odor problems. The filtration process removes the following types of particles:

- Silts and clay
- Colloids
- Biological forms
- Floc

Four Desirable Characteristics of Filter Media

- Good hydraulic characteristics (permeable)
- Does not react with substances in the water (inert and easy to clean)
- Hard and durable
- Free of impurities and insoluble in water

Evaluation of overall filtration process performance should be conducted on a routine basis, at least once per day. Poor chemical treatment can often result in either early turbidity breakthrough or rapid head loss buildup. The more uniform the media, the slower head loss buildup. All water treatment plants that use surface water are governed by the U.S. EPA's Surface Water Treatment Rules or **SWTR**.

Declining Rate Filters

The flow rate will vary with head loss. Each filter operates at the same rate, but can have a variable water level. This system requires an effluent control structure (weir) to provide adequate media submergence.

Detention Time

The actual time required for a small amount of water to pass through a sedimentation basin at a given rate of flow, or the calculated time required for a small amount of liquid to pass through a tank at a given rate of flow.

$$\text{Detention Time} = \frac{\text{Basin Volume, Gallons} (24 \text{ Hours/day})}{\text{Flow, Gallons/day}}$$

Disinfection

Chlorine is added to the water at the flash mix for pre-disinfection. The chlorine kills or inactivates harmful microorganisms. Chlorine is added again after filtration for post-disinfection.

Jar Testing (*More information later in manual. See the Water Quality Section*)

Jar testing traditionally has been done on a routine basis in most water treatment plants to control the coagulant dose. Much more information, however, can be obtained with only a small modification in the conventional method of jar testing. It is the quickest and most economical way to obtain good reliable data on the many variables which affect the treatment process. These include:

- Determination of most effective coagulant.
- Determination of optimum coagulation pH for the various coagulants.
- Evaluation of most effective polymers.
- Optimum point of application of polymers in the treatment train.
- Optimum sequence of application of coagulants, polymers, and pH adjustment chemicals.
- Best flocculation time.

pH

Expression of a basic or acid condition of a liquid. The range is from 0-14, zero being the most acid and 14 being the most alkaline. A pH of 7 is considered to be neutral. Most natural water has a pH between 6.0 and 8.5.

Caustic

NaOH (also called Sodium Hydroxide) is a strong chemical used in the treatment process to neutralize acidity, increase alkalinity, or raise the pH value.

Polymer

A type of chemical, when combined with other types of coagulants, aids in binding small suspended particles to larger particles to help in the settling and filtering processes.

Post-Chlorine

Where the water is chlorinated to make sure it holds a residual in the distribution system.

Pre-Chlorine

Where the raw water is dosed with a large concentration of chlorine.

Pre-Chlorination

The addition of chlorine before the filtration process will help:

- Control algae and slime growth
- Control mud ball formation
- Improve coagulation
- Precipitate iron



Raw Turbidity

The turbidity of the water coming to the treatment plant from the raw water source.

Settled Solids

Solids that have been removed from the raw water by the coagulation and settling processes.

Hydrofluosilicic Acid

(H₂SiF₆) a clear, fuming corrosive liquid with a pH ranging from 1 to 1.5. Used in water treatment to fluoridate drinking water.

Corrosion Control

The pH of the water is adjusted with sodium carbonate, commonly called soda ash. Soda ash is fed into the water after filtration.

Zinc Orthophosphate

A chemical used to coat the pipes in the distribution system to inhibit corrosion.

Taste and Odor Control

Powdered activated carbon (**PAC**) is occasionally added for taste and odor control. PAC is added to the flash mix.

Water Quality

Water testing is conducted throughout the treatment process. Items like turbidity, pH, and chlorine residual are monitored and recorded continuously. Some items are tested several times per day, some once per quarter and others once per year.

Sampling

Collect the water sample at least 6 inches under the surface by plunging the container mouth down into the water and turning the mouth towards the current by dragging the container slowly horizontal. Care should be taken not to disturb the bottom of the water source or along the sides, so as not to stir up any settled solids. This would create erroneous results.

Chemical feed and rapid mix

Chemicals are added to the water in order to improve the subsequent treatment processes. These may include pH adjusters and coagulants. Coagulants are chemicals, such as alum, that neutralize positive or negative charges on small particles, allowing them to stick together and form larger particles that are more easily removed by sedimentation (**settling**) or filtration.

A variety of devices, such as baffles, static mixers, impellers, and in-line sprays can be used to mix the water and distribute the chemicals evenly.

Short-Circuiting

Short-Circuiting is a condition that occurs in tanks or basins when some of the water travels faster than the rest of the flowing water. This is usually undesirable, since it may result in shorter contact, reaction, or settling times in comparison with the presumed detention times.

Tube Settlers

This modification of the conventional process contains many metal "**tubes**" that are placed in the sedimentation basin, or clarifier. These tubes are approximately 1 inch deep and 36 inches long, split-hexagonal shape, and installed at an angle of 60 degrees or less.

These tubes provide for a very large surface area upon which particles may settle as the water flows upwards. The slope of the tubes facilitates gravity settling of the solids to the bottom of the basin, where they can be collected and removed. The large surface settling area also means that adequate clarification can be obtained with detention times of 15 minutes or less. As with conventional treatment, this sedimentation step is followed by filtration through mixed media.

Adsorption Clarifiers

The concept of the adsorption clarifier package plant was developed in the early 1980's. This technology uses an up-flow clarifier with low-density plastic bead media, usually held in place by a screen. This adsorption media is designed to enhance the sedimentation/clarification process by combining flocculation and sedimentation into one step. In this step, turbidity is reduced by adsorption of the coagulated and flocculated solids onto the adsorption media and onto the solids already adsorbed onto the media.

Air scouring cleans adsorption clarifiers followed by water flushing. Cleaning of this type of clarifier is initiated more often than filter backwashing because the clarifier removes more solids. As with the tube-settler type of package plant, the sedimentation/clarification process is followed by mixed-media filtration and disinfection to complete the water treatment.

Clearwell

The final step in the conventional filtration process, the clearwell provides temporary storage for the treated water. The two main purposes for this storage are to have filtered water available for backwashing the filter, and to provide detention time (or contact time) for the chlorine (or other disinfectant) to kill any microorganisms that may remain in the water.



Dried backwash channels on top of a cleaned filter bed.





Pretreatment sedimentation basin, bottom photograph, sludge drying bed with new grass. Time to turn the sludge over.



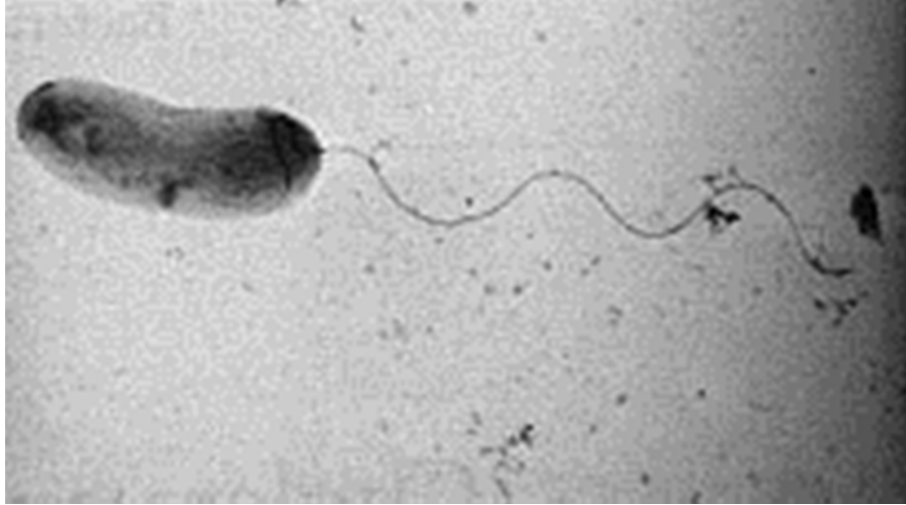

Cholera



EPA Filter Backwash Rule

The U.S. Environmental Protection Agency (**EPA**) has finalized the Long Term 1 Enhanced Surface Water Treatment Rule and Filter Backwash Rule (**LT1FBR**) to increase protection of finished drinking water supplies from contamination by ***Cryptosporidium*** and other microbial pathogens.

This rule will apply to public water systems using surface water or ground water under the direct influence of surface water. This rule will extend protections against ***Cryptosporidium*** and other disease-causing microbes to the 11,500 small water systems which serve fewer than 10,000 people annually.

This rule also establishes filter backwash requirements for certain public water systems of all sizes. The filter backwash requirements will reduce the potential risks associated with recycling contaminants removed during the filtration process.

Background

The Safe Drinking Water Act (**SDWA**) requires the EPA to set enforceable standards to protect public health from contaminants which may occur in drinking water. The EPA has determined that the presence of microbiological contaminants is a health concern. If finished water supplies contain microbiological contaminants, disease outbreaks may result. Disease symptoms may include diarrhea, cramps, nausea, possibly jaundice, and headaches and fatigue. The EPA has set enforceable drinking water treatment requirements to reduce the risk of waterborne disease outbreaks. Treatment technologies such as filtration and disinfection can remove or inactivate microbiological contaminants.

Physical removal is critical to the control of *Cryptosporidium* because it is highly resistant to standard disinfection practice. Cryptosporidiosis may manifest itself as a severe infection that can last several weeks and may cause the death of individuals with compromised immune systems. In 1993, *Cryptosporidium* caused over 400,000 people in Milwaukee to experience intestinal illness. More than 4,000 were hospitalized, and at least 50 deaths were attributed to the cryptosporidiosis outbreak.

The 1996 Amendments to SDWA require the EPA to promulgate an Interim Enhanced Surface Water Treatment Rule (**IESWTR**) and a Stage 1 Disinfection Byproducts Rule (announced in December 1998). The IESWTR set the first drinking water standards to control *Cryptosporidium* in large water systems, by establishing filtration and monitoring requirements for systems serving more than 10,000 people each. The LT1FBR proposal builds on those standards by extending the requirements to small systems.

The 1996 Amendments also required the EPA to promulgate a Long Term 1 Enhanced Surface Water Treatment Rule (for systems serving less than 10,000 people) back in November, 2000 ((1412(b)(2)(C))) and also require the EPA to “**promulgate a regulation to govern the recycling of filter backwash water within the treatment process of a public water system**” back in August, 2000 ((1412(b)(14))). The current rule includes provisions addressing both of these requirements.

What will the LT1FBR require?

The LT1FBR provisions will apply to public water systems using surface water or ground water under the direct influence of surface water systems.

LT1 Provisions - Apply to systems serving fewer than 10,000 people, and fall into the three following categories:

Turbidity

- Conventional and direct filtration systems must comply with specific combined filter effluent turbidity requirements;
- Conventional and direct filtration systems must comply with individual filter turbidity requirements;

Disinfection Benchmarking

- Public water systems will be required to develop a disinfection profile unless they perform applicability monitoring which demonstrates their disinfection byproduct levels are less than 80% of the maximum contaminant levels;
- If a system considers making a significant change to their disinfection practice they must develop a disinfection benchmark and receive State approval for implementing the change.

Other Requirements

- Finished water reservoirs for which construction begins after the effective date of the rule must be covered; and
- Unfiltered systems must comply with updated watershed control requirements that add *Cryptosporidium* as a pathogen of concern.

FBR Provisions - Apply to all systems which recycle regardless of population served:

- Recycle systems will be required to return spent filter backwash water, thickener supernatant, and liquids from the dewatering process prior to the point of primary coagulant addition unless the State specifies an alternative location;
- Direct filtration systems recycling to the treatment process must provide detailed recycle treatment information to the State, which may require that modifications to the recycle practice be made, and;
- Conventional systems that practice direct recycle, employ 20 or fewer filters to meet production requirements during a selected month, and recycle spent filter backwash water, thickener supernatant, and/or liquids from the dewatering process within the treatment process must perform a one month, one-time recycle self-assessment. The self-assessment requires hydraulic flow monitoring and that certain data be reported to the State, which may require that modifications to the recycle practice be made to protect public health.



Often under the filtration basins are work tunnels, complex machinery, gauges and huge water pumps.

The Filtration Process

Removal of suspended solids by filtration plays an important role in the natural treatment of groundwater as it percolates through the soil. It is also a major part of most water treatment. Groundwater that has been softened or treated through iron and manganese removal will require filtration to remove floc created by coagulation or oxidation processes. Since surface water sources are subject to run-off and do not undergo natural filtration, it must be filtered to remove particles and impurities.

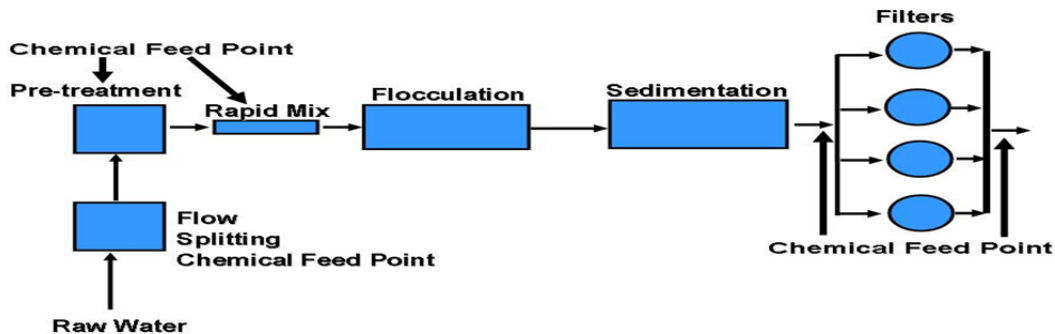

The filter used in the filtration process can be compared to a sieve or microstrainer that traps suspended material between the grains of filter media. However, since most suspended particles can easily pass through the spaces between the grains of the filter media, straining is the least important process in filtration.



The photograph on the right illustrates debris removed during the backwash process. The particles are trapped on top of the filter media and trapped within the media.

Filtration primarily depends on a combination of complex physical and chemical mechanisms, the most important being adsorption. Adsorption is the process of particles sticking onto the surface of the individual filter grains or onto the previously deposited materials. The forces that attract and hold the particles to the grains are the same as those that work in coagulation and flocculation. In fact, some coagulation and flocculation may occur in the filter bed, especially if coagulation and flocculation of the water before filtration was not properly controlled. Incomplete coagulation can cause serious problems in filter operation.



The photo on the right shows small glass beads laid on top of a sieve.



Filtration Methods: The conventional type of water treatment filtration method includes coagulation, flocculation, sedimentation, and filtration. Direct filtration method is similar to conventional except that the sedimentation step is omitted. Slow sand filtration process does not require pretreatment, has a flow of 0.1 gallons per minute per square foot of filter surface area, and is simple to operate and maintain. Diatomaceous earth method uses a thin layer of fine siliceous material on a porous plate. This type of filtration medium is only used for water with low turbidity. Sedimentation, adsorption, and biological action treatment methods are a filtration process that involves a number of interrelated removal mechanisms. Demineralization is primarily used to remove total dissolved solids from industrial wastewater, municipal water, and seawater.

Types of Filters

Several types of filters are used for water treatment. The earliest ones developed were the slow sand filters. They typically have filter rates of around 0.05 gpm/ft² of surface area. This type of filter requires large filter areas. The top several inches of the sand has to be removed regularly, usually by hand due to the mass of growing material ("*schmutzdecke*") that collects in the filter. The sand removed is usually washed and returned to the filter. These filters are still in use in some small plants, especially in the western United States, as well as in many developing countries. They may also be used as a final step in wastewater treatment. Most filters are classified by filtration rate, type of filter media, or type of operation into:

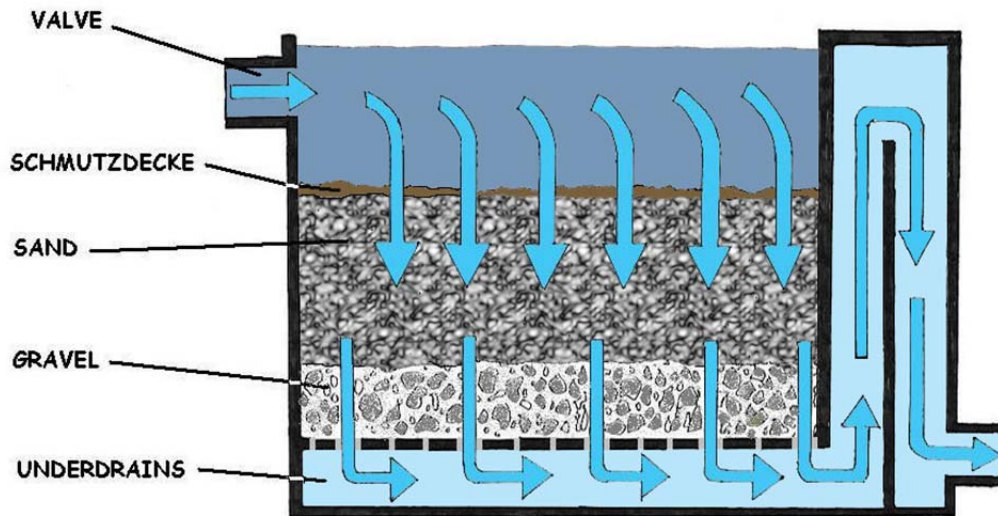

SLOW SAND FILTER

A. Gravity Filters

1. Rapid Sand Filters
2. High Rate Filters
 - Dual media
 - Multi-media

B. Pressure Filters

- Sand or Multi-media

Rapid Sand Filters

Rapid sand filters can accommodate filter rates 40 times those of slow sand filters. The major parts of a rapid sand filter are:

- ◆ Filter tank or filter box
- ◆ Filter sand or mixed-media
- ◆ Gravel support bed
- ◆ Underdrain system
- ◆ Wash water troughs
- ◆ Filter bed agitators

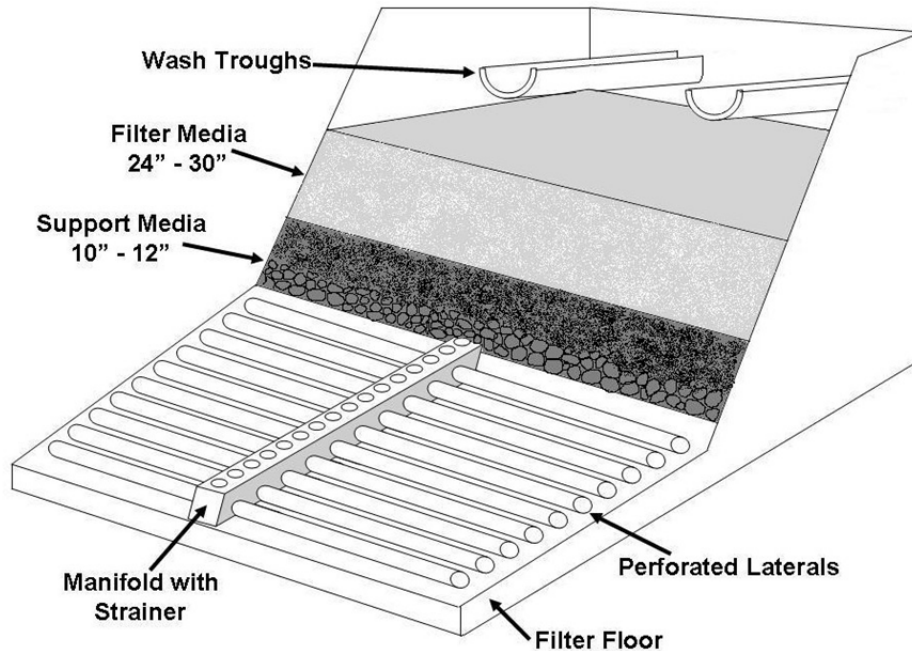

The filter tank is generally constructed of concrete and is most often rectangular. Filters in large plants are usually constructed next to each other in a row, allowing the piping from the sedimentation basins to feed the filters from a central pipe gallery. Some smaller plants are designed with the filters forming a square of four filters with a central pipe gallery feeding the filters from a center well.

Filter Sand

The filter sand used in rapid sand filters is manufactured specifically for the purpose of water filtration. Most rapid sand filters contain 24-30 inches of sand, but some newer filters are deeper. The sand used is generally 0.4 to 0.6 mm in diameter. This is larger than the sand used in slow rate filtration. The coarser sand in the rapid filters has larger voids that do not fill as easily. The gravel installed under the sand layer(s) in the filter prevents the filter sand from being lost during the operation. The under-gravel also distributes the backwash water evenly across the total filter. This under-gravel supports the filter sand and is usually graded in three to five layers, each generally 6-18 inches in thickness, depending on the type of underdrain used.

Underdrain

The filter underdrain can be one of many types, such as:

- ◆ Pipe laterals
- ◆ False floor
- ◆ Leopold system
- ◆ Porous plates or strainer nozzles
- ◆ Pipe laterals

A pipe lateral system uses a control manifold with several perforated laterals on each side. Piping materials include cast iron, asbestos cement, and PVC. The perforations are usually placed on the underside of the laterals to prevent them from plugging with sand. This also allows the backwash to be directed against the floor, which helps keep the gravel and sand beds from being directly disturbed by the high velocity water jets.

False floor

The false floor design of a filter underdrain is used together with a porous plate design or with screens that retain the sand when there is no undergravel layer. This type of underdrain allows the plenum or open space under the floor to act as the collection area for the filtered water and for the distribution of the filter backwash water.

Leopold system

The Leopold system consists of a series of clay or plastic blocks that form the channels to remove the filtered water from the filter and distribute the backwash water. This type of underdrain is generally used with an undergravel layer, although some new designs allow for sand retention without gravel.

Washwater Troughs

Washwater troughs placed above the filter media collect the backwash water and carry it to the drain system. Proper placement of these troughs is very important to ensure that the filter media is not carried into the troughs during the backwash and removed from the filter. The wash troughs must be installed at the same elevation so that they remove the backwash evenly from the filter and so that an even head is maintained across the entire filter. These backwash troughs are constructed from concrete, plastic, fiberglass, or other corrosion-resistant materials.

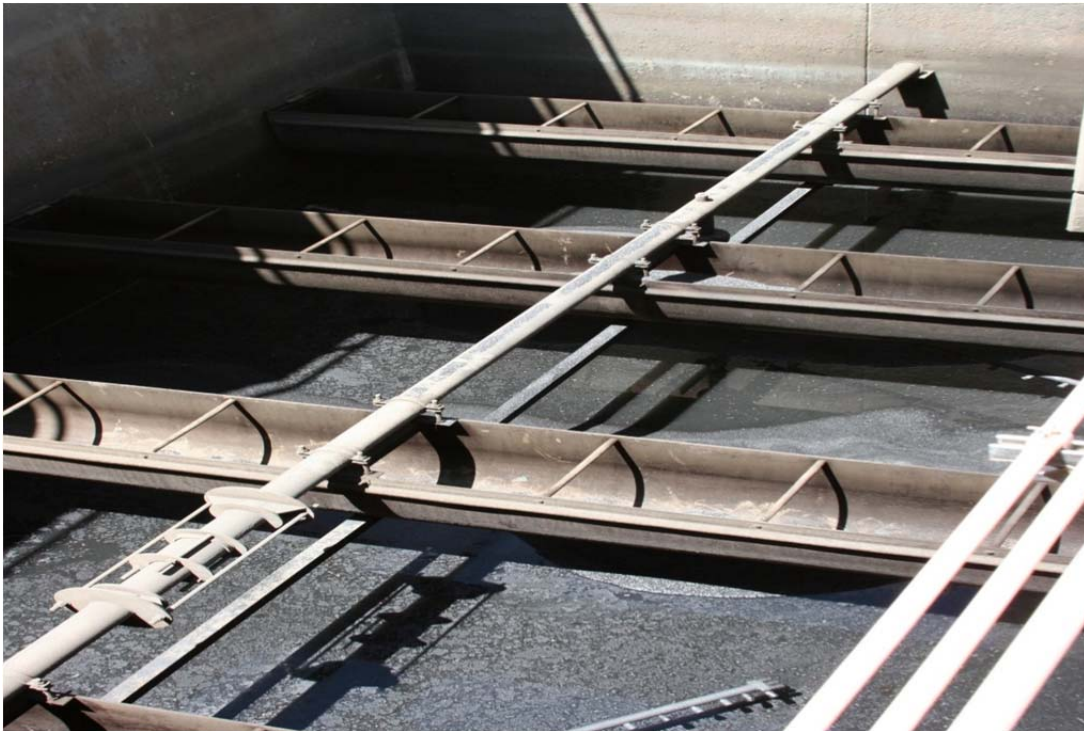

The photograph above shows exposed filter troughs.

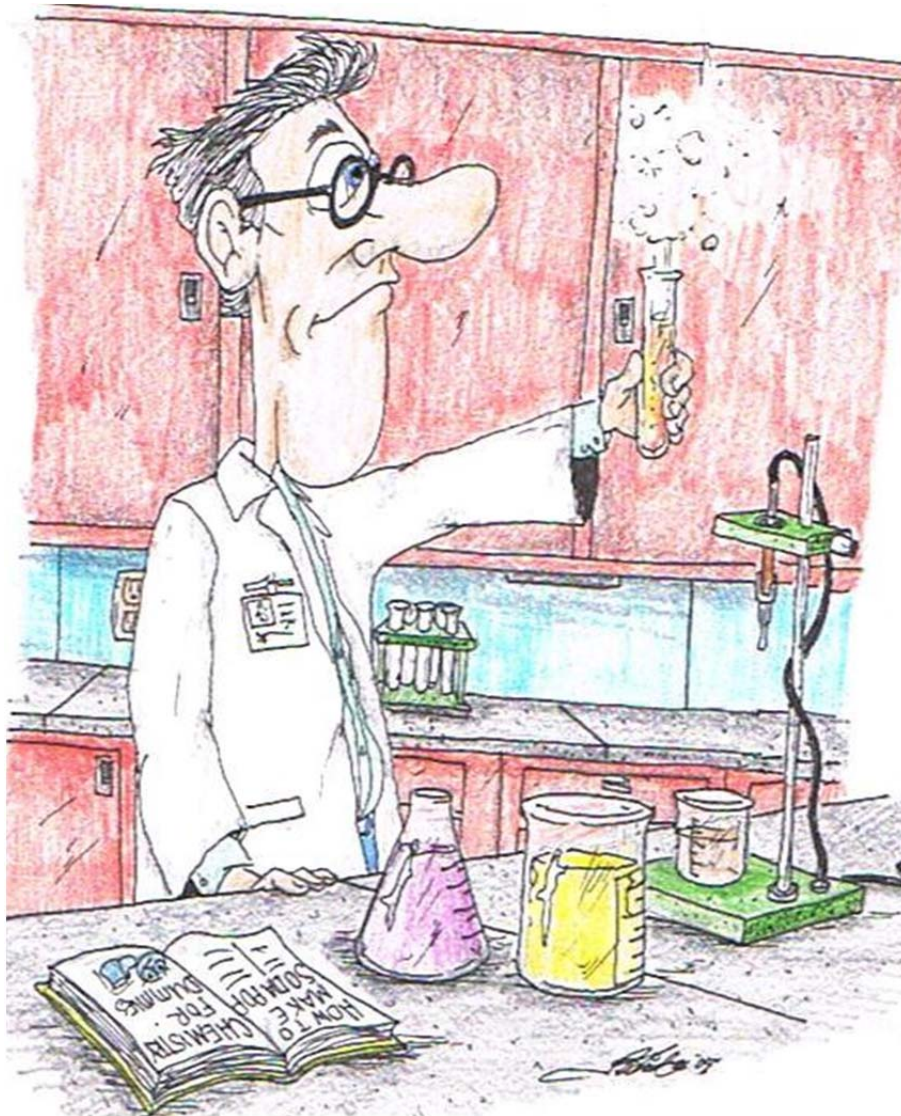

Nature of turbidity: The turbidity in natural surface waters is composed of a large number of sizes of particles. The sizes of particles can be changing constantly, depending on precipitation and manmade factors. When heavy rains occur, runoff into streams, rivers, and reservoirs occurs, causing turbidity levels to increase. In most cases, the particle sizes are relatively large and settle relatively quickly in both the water treatment plant and the source of supply. However, in some instances, fine, colloidal material may be present in the supply, which may cause some difficulty in the coagulation process.

Generally, higher turbidity levels require higher coagulant dosages. However, seldom is the relationship between turbidity level and coagulant dosage linear. Usually, the additional coagulant required is relatively small when turbidities are much higher than normal due to higher collision probabilities of the colloids during high turbidities. Conversely, low turbidity waters can be very difficult to coagulate due to the difficulty in inducing collision between the colloids. In this instance, floc formation is poor, and much of the turbidity is carried directly to the filters. Organic colloids may be present in a water supply due to pollution, and these colloids can be difficult to remove in the coagulation process. In this situation, higher coagulant dosages are generally required.

Surface Wash



The photograph above shows a drained filter with the agitator and nozzles exposed. During operation these will spin, spraying water during the water backwash.

During the operation of a filter, the upper six-to-ten inches of the filter media remove most of the suspended material from the water. It is important that this layer be thoroughly cleaned during the backwash cycle. Normal backwashing does not, in most cases, clean this layer completely; therefore, some method of agitation is needed to break up the top layers of the filter and to help the backwash water remove any material caught there.



The surface wash system consists of a series of pipes installed in the filter that introduce high velocity water or air jet action into the upper layer of the filter. This jet action will generally be supplied by rotating arms that are activated during the backwashing of the filter.

A newer design of surface wash uses compressed air to mix the upper layer and loosen the particles from the sand so that the backwash water can remove the particles more easily. This air wash generally is turned on before the backwash cycle. If both are used at the same time, some sand may be washed away. The compressed air rate can be two-to-five cubic feet per minute per square foot (cfm/ft²) of filter surface, depending on the design of the filter.

High Rate Filters

High rate filters, which operate at a rate three-to-four times that of rapid sand filters, use a combination of different filter media, not just sand. The combinations vary with the application, but generally they are sand and anthracite coal. Multi-media or mixed-media filters use three or four different materials, generally sand, anthracite coal, and garnet.



In this photograph you can see the water lines on the wall of the filter. The deeper the water the more head pressure exerted on the filter media.

In rapid sand filters, finer sand grains are at the top of the sand layer with larger grains farther down into the filter. As a result, the filter removes more suspended material in the first few inches of the filter. In the high rate filter, the media size decreases. The top layers consist of a coarse material with the finer material farther down, allowing the suspended material to penetrate deeper into the filter.

The material in a filter bed forms layers in the filter, depending on their weight and specific gravities. In the coarse layer at the top, the larger suspended particles are removed first, followed by the finer materials. This allows for longer filter runs at higher rates than is possible with rapid sand filters.

The type of filter media used in a high rate filter depends on many factors, including the raw-water quality, raw-water variations, and the chemical treatment used. Pilot studies help the operator evaluate which material, or combination of materials, will give the best result.

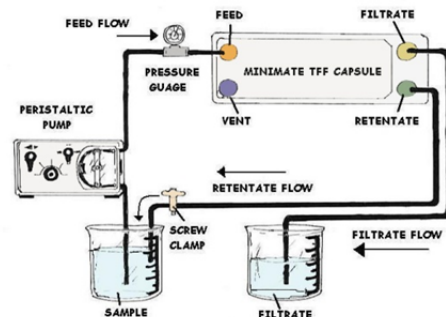

LABORATORY FILTRATION SYSTEM

Pressure Filters

Pressure filters fall into two categories: pressure sand and diatomite filters.

Pressure Sand Filters

This type of filter is used extensively in iron and manganese removal plants.

A pressure sand filter is contained under pressure in a steel tank, which may be vertical or horizontal, depending on the space available. As with gravity filters, the media is usually sand or a combination of media. Filtration rates are similar to gravity filters.

These filters are commonly used for iron and manganese removal from groundwater, which is first aerated to oxidize the iron or manganese present, then pumped through the filter to remove the suspended material.



Filter Media

Because the water is under pressure, air binding will not occur in the filter. However, pressure filters have a major disadvantage in that the backwash cannot be observed; in addition, cracking of the filter bed can occur quite easily, allowing the iron and manganese particles to go straight through the filter. When using pressure filters for iron and manganese removal, the operator must regularly measure the iron and manganese concentration of the filter effluent and backwash the filter before breakthrough occurs. Because of these limitations, pressure filters must not be used to treat surface water.

Diatomaceous Earth Filter

This type of filter is commonly used for the treatment of swimming pools. The process was developed by the military during World War II to remove microorganisms that cause amoebic dysentery from water used in the field.



Filtration Processes

al
ly
es
ed

Surface Water Conventional Treatment: 50 MGD

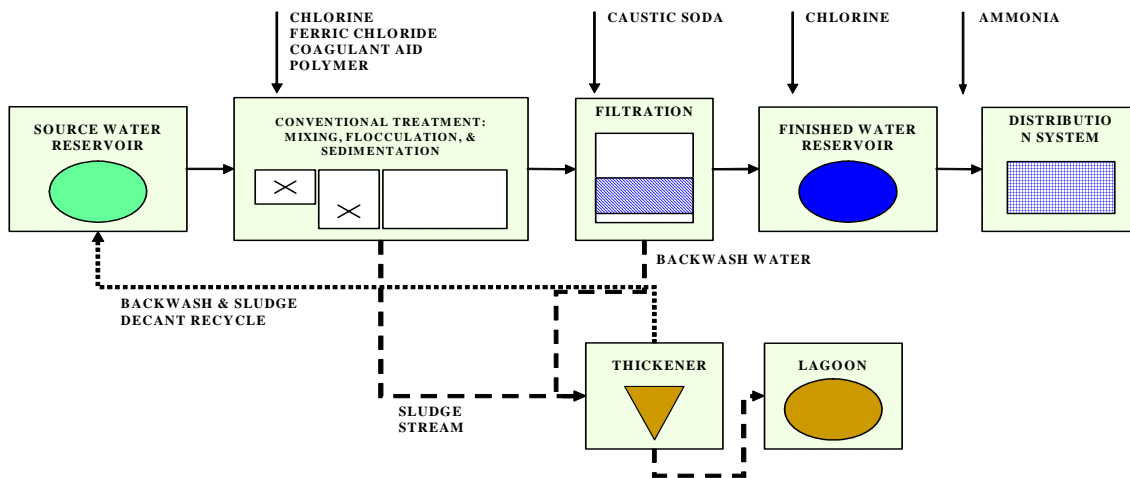

After sedimentation, the water passing through to the filters should not have turbidity higher than 10-to-15 NTU. Rapid sand filters were once used in the conventional process, but many have been converted to multi-media filters in an attempt to increase plant capacity.

In the other type of filtration process--direct filtration--no sedimentation follows the coagulation phase. Direct filtration is designed to filter water with an average turbidity of less than 25 NTU. Dual and multi-media filters are used with direct filtration. They are able to remove more suspended material per cubic foot of filter media than sand filters. Direct filtration plants have a lower capital cost. However, the process cannot handle large variations in raw water turbidity.



Filtration Operation

Filtration operation is divided into three steps: filtering, backwashing, and filtering to waste.

Filter Control of the filter operation requires the following equipment:

- ◆ Rate of flow controller
- ◆ Loss of head indicator
- ◆ On-line turbidimeter

Rate of Flow Controllers

Flow rates through filters are controlled by one of two different methods:

Declining rate

This method of control is used where the head loss through the plant is quite large. It allows the filter head to increase until the filter becomes plugged with particles and the head loss is too great to continue operation of the filter. The rate through the filter is much greater in the beginning of a filter run than at the end when the filter is dirty. This method tends to be the most commonly installed in new filter plants.

The photograph on right shows operators walking through the filter gallery of a plant that uses declining rate filters. This is also showing pipelines to and from the filter boxes.



Constant rate

This type of control monitors the level of water on the top of the filter and attempts to control this level from the start of the operation to the end. This is accomplished by the controller operating a valve on the effluent of the filter. The valve will be nearly closed at the start of the filter run and fully open at the end. This design is used when the head or pressure on the filter is limited.



The photograph above shows the overflow in case the filter level gets too high.

Both controllers consist of a venturi tube or some other type of metering device, as well as a valve to control the flow from the filter. In most cases, the valve is controlled by an automatic control device, often an air-actuated type valve that is controlled by the flow tube controller.

Loss of head indicator

As filtration proceeds, an increasing amount of pressure, called head loss across the filter, is required to force the water through the filter. The head loss should be continuously measured to help determine when the filter should be backwashed.

Usually the difference in the head is measured by a piezometer connected to the filter above the media and the effluent line.

In-line turbidimeter

Turbidity in water is caused by small suspended particles that scatter or reflect light so that the water appears to be cloudy. Turbidity of the filtered water may shelter bacteria, preventing chlorine from reaching it during the final disinfection process. The turbidity of the filtered water is one of the factors that determine the length of a filter run. At some point, the suspended material will start to break through the filter media and increase the turbidity of the filter effluent. At this time, the filter should be backwashed. Continuous turbidity monitors provide information about when the filter is approaching this point so that the operators can start the backwash before the turbidity is too great. Turbidity measurements will also indicate whether the coagulation and other treatment processes are operating properly.



Media	Anthracite coal
Flow rate	10 mgd
Volume	75,000 gal
Depth to media	7.5 ft



Filtration Process

Water from the source or, more commonly, from pre-treatment processes, is applied to the top of the filter; it then flows downward. The water level above the filter bed is usually kept at two-to-six feet. When the filtration is started after being backwashed, there will be little head loss. In filters with a control valve installed on the filter effluent pipe, the filter flow is restricted during this time. The control valve also has the important function of preventing filter surges, which could disturb the media and force floc through the filter.

The rate of flow on a filter depends on the type of filter. A rapid sand filter will have a flow of two-to-three gpm/square foot of filter area. The high rate filter may have four-to-six gpm/square foot applied to the surface. A constant rate flow valve is almost fully closed when a filter is clean so that the desired water level on top of the filter is maintained. As the filter becomes dirty with suspended material, the valve opens gradually until the increase in the water level above the filter indicates that the filter needs backwashing.

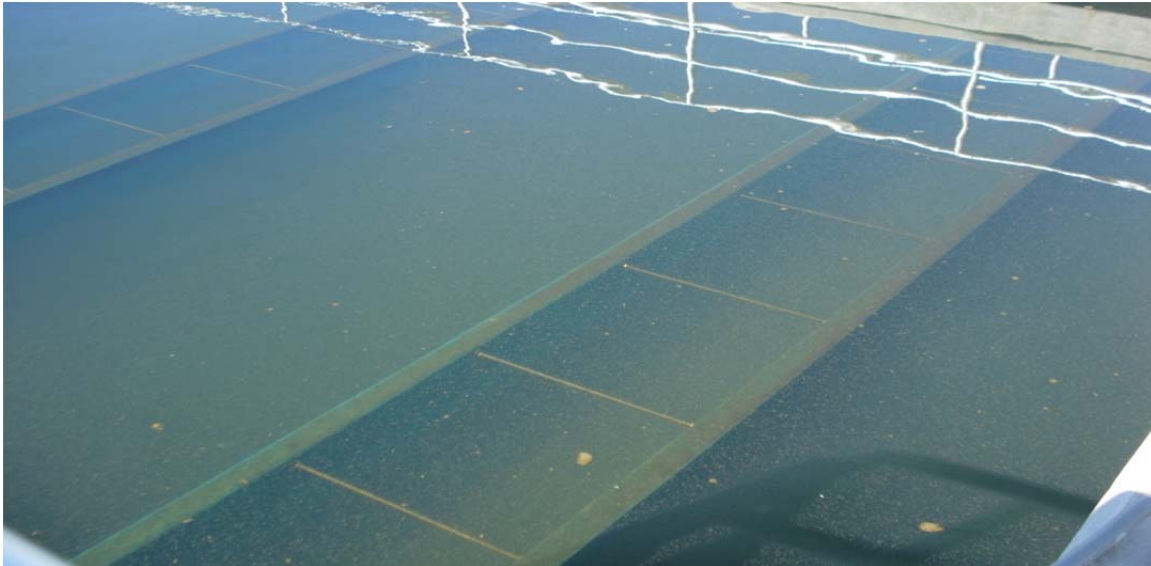

The above photograph is a filter from a direct filtration plant; notice the size of the floc.

In filters with variable declining rate flow control, the filters are allowed to take on as much water as they can handle. As the filters become dirty, both the headloss and the depth of the water on the surface increase until the filters need backwashing. This method is generally preferred because it requires less operator attention. With this method, a filter accepts as much flow as it can handle. As the filter becomes dirty, the flow through the filter becomes less and, if the plant has more than one filter, additional flow redistributes across the other filters. A flow restrictor is placed in the filter effluent pipe to prevent a filter inflow that is too great for the filter.

Regardless of the method of control, the filter eventually fills with suspended material. At some time, usually after 15 to 30 hours, it will need to be backwashed to clean the media.

Back Washing

Proper backwashing is a very important step in the operation of a filter. If the filter is not backwashed completely, it will eventually develop additional operational problems. If a filter is to operate efficiently, it must be cleaned before the next filter run. Treated water from storage is used for the backwash cycle. This treated water is generally taken from elevated storage tanks or pumped in from the clear well.

During filtration, the filter media becomes coated with the floc, which plugs the voids between the filter grains, making the filter difficult to clean. The media must be expanded to clean the filter during the backwash. This expansion causes the filter grains to violently rub against each other, dislodging the floc from the media.

The filter backwash rate has to be great enough to expand and agitate the filter media and suspend the flocs in the water for removal. However, if the filter backwash rate is too high, media will be washed from the filter into the troughs and out of the filter. A normal backwash rate is between 12 to 15 gpm per square foot of filter surface area.

In most cases the filter backwash rate will not break up the mass on the top of the filter. The design engineer will recommend the installation of a surface wash of some type, the most common being a set of rotary arms that are suspended above the media during filtration. During filter backwash, the media expands upwards and around the washing arms. A newer method of surface wash involves using air scour before the water wash. This is a very efficient method, but requires the installation of a large air blower to produce the air. The normal design for the air wash will be two-to-five cubic feet of air per square foot of filter area.



Both photographs are part of the backwash equipment for the water plant.

The filter should be backwashed when the following conditions have been met:

- ◆ The head loss is so high that the filter no longer produces water at the desired rate; and/or
- ◆ Floc starts to break through the filter and the turbidity in the filter effluent increases; and/or
- ◆ A filter run reaches a given hour of operation.
- ◆ If a filter is taken out of service for some reason, it must always be backwashed prior to be putting on line.

The decision to backwash the filter should not be based on only one of the above conditions. If a filter is not backwashed until the headloss exceeds a certain number of feet, the turbidity may break through and cause the filter to exceed the standard of 0.5 NTU of turbidity.

Similarly, depending on filter effluent-turbidity alone can cause high head loss and decreased filter flow rate, which can cause the pressure in the filter to drop below atmospheric pressure and cause the filter to air bind and stop filtering.

If the water applied to a filter is very good quality, the filter runs can be very long. Some filters can operate longer than one week before needing to be backwashed. However, this is not recommended as long filter runs can cause the filter media to pack down so that it is difficult to expand the bed during the backwash.

Backwashing Process

The normal method for backwashing a filter involves draining the water level above the filter to a point six inches above the filter media. The surface wash is then turned on and allowed to operate for several minutes to break up the crust on the filter.

After that, the backwash valve is opened, allowing backwash water to start flowing into the filter and start carrying suspended material away from the filter. For a filter with an air wash instead of a water-surface wash, the filter backwash water and the air wash should not be used together. This would be possible only if some means of controlling the media carryover is installed.





This is a filter control panel.

The time elapsed from when the filter wash is started until full flow is applied to the filter should be greater than one minute. After a few minutes, the filter backwash valve should be fully opened to allow full expansion of the filter media. Generally, this expansion will be from 20 to 40 percent over the normal filter bed volume. The expansion needed will depend on how much agitation is needed to suspend the filter media to remove to suspended material trapped in the filter. With a multi-media filter, the rate must be high enough to scrub the interface between the coal and the sand, where the highest amount of suspended solids will be removed from the media. The filter will be washed for 10 to 15 minutes, depending on the amount of solids that must be removed. The best way to determine how long the filter should be washed is to measure the turbidity of the backwash water leaving the filter. In most cases, a filter is washed too long. This could be costly. Too much backwash water is used, and it must be treated after use. Backwash valves must be opened slowly. Opening the valves too rapidly can cause serious damage to the filter underdrain, filter gravel, and filter media.

Disposal of Filter Backwash Water

Water from the filter backwash cannot be returned directly to the environment. Normally the water is discharged into a backwash tank and allowed to settle. The supernatant, or cleared liquid, is then pumped back to the head of the treatment plant at a rate not exceeding ten percent of the raw water flow entering the plant. The settled material is pumped to a sewer or is treated in the solids-handling process of the plant. This conserves most of the backwash water and eliminates the need to obtain a pollution discharge permit for the disposal of the filter backwash water.



Since backwash is a very high flow operation, the surges that are created from the backwash coming from the filter must not be allowed to enter the head of the plant. Therefore, the spent backwash water must be stored in storage tanks and returned slowly to the treatment process.

Filter to Waste

When filtration is started after backwash, filtered water should be wasted until the turbidity in the effluent meets standards. Depending on the type of filter, this may last from two to 20 minutes. This wasting is needed as some suspended material remains in the filter media following the backwash. The media needs to become somewhat sticky again to start to capture the suspended material.

Also, the filtration rate is higher in a clean filter, causing more material to be swept from the filter during the start-up. Filtration should always be started slowly after a backwash to prevent breakthrough of suspended material.



Filter Aids

Sometimes, when water passes through a filter, the floc is torn apart into smaller particles that will penetrate deeply into the filter media, causing premature turbidity breakthrough. This will require more frequent filter backwashing of the filter and use of large volumes of backwash water to be able to remove the floc that has penetrated deeply into the filter bed. A filter aid is a material that adds strength to the floc and prevents its breakup. Generally, a polymer is used as a filter aid because it creates strong bonds with the floc. Polymers are water-soluble, organic compounds that can be purchased in either wet or dry form.





The photograph on the right is showing dry Polymer and on the left side is liquid.

Polymers have very high molecular weight and cause the floc to coagulate and flocculate quickly. Polymers can have positive or negative charges, depending on the type needed to cause attraction to the specific floc filtered.

When used as a filter aid, the polymer strengthens the bonds and prevents the shearing forces in the filter from breaking the floc apart. For best results, the polymer should be added just ahead of the filter. A normal dose of polymer for filter aiding will be less than 0.1 ppm, but the exact dose will be decided by the result of a jar test and by experimentation in the treatment plant. Too much polymer will cause the bonds to become too strong, which may then cause the filter to plug, especially the top few inches of the filter media.

Filter Operating Problems

There are three major types of filter problems. They can be caused by chemical treatment before the filter, control of filter flow rate, and backwashing of filters.



The above photograph shows clumps formed by Powder Activated Carbon.

Chemical Treatment before the Filter

The coagulation and flocculation stages of the water treatment must be monitored continuously. Adjustments in the amount of coagulant added must be made frequently to prevent the filter from becoming overloaded with suspended material. This overload may cause the filter to prematurely reach its maximum headloss.

If there is early turbidity breakthrough in the filter effluent, more coagulant may have to be added to the coagulation process. There may be a need for better mixing during the coagulation or the addition of more filter aid.

If there is a rapid increase in filter head loss, too much coagulant may be clogging the filter. Less coagulant or less filter aid should be used. The operator needs to learn to recognize these problems and choose the proper corrections.



Filter aid being fed at the weirs of sedimentation.



In the photograph above, overfeeding flocculants to meet federal regulations caused Iron to precipitate on the filter walls.

Control of Filter Flow Rate

When a filter is subjected to rapid changes in flow rate, the turbidity of the effluent may be affected; the dirtier the filter media, the greater the effect.

When a plant flow changes, the filter flow also has to change to produce the water needed. If an increase is necessary, the flow should, if possible, be increased gradually over a ten-minute period to reduce the impact on the filter. Addition of filter aids may also reduce the impact on the filter effluent.

When backwashing a filter and therefore temporarily taking it out of service, the remaining filter(s) must pick up the additional flow. This can cause an abrupt change in flow that will cause turbidity breakthrough. This problem can be avoided by keeping one filter in reserve to accept this additional flow. If the plant has a backwash storage basin, this will also prevent surges to the filters.

Filter No.	DCS	Add	Flow	Turbidity	Flow	Turbidity	Flow	Turbidity	Flow	Turbidity	Flow	Turbidity
Filter No. 9	DCS	Add										
Filter No. 10	DCS	Add										
Filter No. 11	DCS	Add										
Filter No. 12	DCS	Add	Enabled	0.09	0.25	29.5	60.0	5.27	1.00	3.07	6.00	
Filter No. 13	DCS	Add	Enabled	0.09	0.30	9.6	72.0	7.36	1.00	3.98	6.00	
Filter No. 14	DCS	Add	Enabled	0.08	0.25	47.7	60.0	7.30	1.00	6.57	7.00	
Filter No. 15	DCS	Add	Enabled	0.08	0.25	39.5	60.0	7.18	1.00	6.78	6.00	
Filter No. 16	DCS	Add	Enabled	0.08	0.25	14.2	60.0	8.60	1.00	5.83	6.00	
Filter No. 17	DCS	Add	Enabled	0.07	0.25	90.2	60.0	7.84	1.00	5.38	6.00	
Filter No. 18	DCS	Add	Enabled	0.10	0.30	5.2	60.0	7.42	1.00	3.90	6.00	
Filter No. 19	DCS	Add	Enabled	0.08	0.25	15.1	60.0	6.31	1.00	4.87	6.00	

Many plants are not operated continuously, and the start-up at the beginning of the day will cause a surge to the filter(s). The filters should be backwashed before putting them back into operation or operated to waste until the effluent meets the standards.

Backwashing of Filters

Backwashing of the filters is the single most important operation in the maintenance of the filters. If the filter is not backwashed effectively, problems may occur that may be impossible to correct without totally replacing the filter media. These problems could be caused by improper backwashing procedures:

- ◆ Mud balls are formed by the filter media cementing together with the floc that the filter is supposed to remove. If the filter is backwashed effectively, the mud balls are broken apart and removed. As the balls gain weight, they will settle to the bottom of the filter and occupy valuable filter volume. This will cause the flow to increase in the areas of the filter that have not been plugged. Additional problems, such as filter cracking and separation of the media from the filter walls may also be the result of mud-ball formation.
- ◆ Filter bed shrinkage or compaction can result from ineffective backwashing. Media grains in a clean filter rest directly against each other with very little compaction.

- ◆ Filter media in a dirty filter are surrounded by a soft layer which causes it to compact. This causes filter bed cracking and separation of the filter media from the walls of the filter. When the filter is cracked, it is obvious that the filter will short circuit. The flow will seek the crack and go straight through, resulting in excessive turbidity in the effluent.



A photograph of a backwash basin that has media caked on the bottom.

- ◆ Separation of the gravel is caused by the backwash valve opening too quickly; as a result, the supporting gravel is forced to the top of the filter. This could also be caused by the filter underdrain being plugged, causing uneven distribution of the backwash water. When this happens, a boil occurs from the increased velocity in the filter. The filter media will start washing into the filter underdrain system and be removed from the filter. If displacement has occurred, the filter media must be removed from the filter and the filter rebuilt by the placement of each grade of media in its proper place.
- ◆ Air binding of the filter is not common as long as the filter is washed regularly. Air binding is the result of pressure in the filter becoming negative during operation. This causes the air dissolved in the water to come out of the solution and become trapped in the filter, resulting in resistance and short filter runs. This negative head generally occurs in a filter that has less than five feet of head above the unexpanded filter bed. If a filter head of five feet is not possible, filter backwash should be started at a lower head loss than normal.



The photograph on the right shows a filter support bed under construction.

Air binding can also be caused by the water being cold and super-saturated with air. This air bubbles out as the water warms up. It is not possible for the operator to control this situation. If it happens, the filter must be backwashed more frequently to correct the filter air binding.

- ◆ Media loss is normal in any filter. Some are lost each time the filter is backwashed, especially if the filter surface wash is used. If a large amount of media is being lost, the method of washing should be inspected and corrected. The bed should not have to be expanded more than 20 percent during the backwash cycle. It may help to turn off the surface wash approximately two minutes before the end of the backwash. If this does not correct the problem, the filter troughs may have to be raised to prevent the excessive media loss.

Filter On-Line

After a well-operated filter backwash, the filter should be level and smooth with no cracks or mud balls at the surface. A good bed will appear to move laterally during the backwash and there will be no boils at the surface. The filter should clear up evenly cleaning. If some areas are not clean, there could be an under-drain problem.

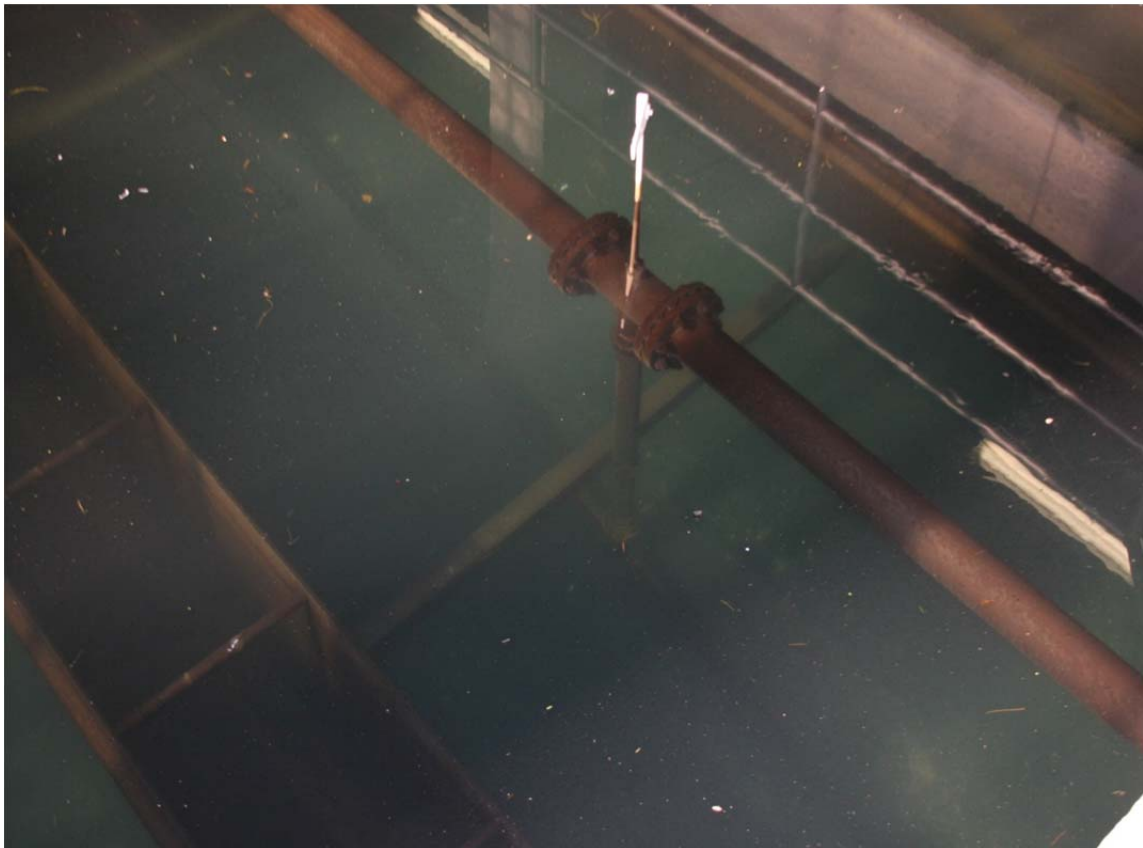

Mudballs can be seen on the top layer of the media bed or during the backwash water cycle. Typically, these will not flow over into the filter troughs.

More on Water Treatment Chemicals

Similar chemicals are used for process control, odor control and sludge conditioning in Water and Wastewater Treatment. Students will learn about the types of chemicals used and how they react in the process. Students will also learn about chemical safety and perform on-site equipment assessment.

The table below is a list of **general** chemicals used in Water and Wastewater. They may vary by the manufacture; a perfect example would be Thioguard®, which is Magnesium Hydroxide. In this class we will discuss the chemical name and compound and leave out manufacture trade names.

Common Water/Wastewater Treatment Chemicals

Chemical Name	Common Name	Chemical Formula	pH (Raise or Lowers)
Aluminum hydroxide		Al(OH) ₃	
Aluminum sulfate	Alum, liquid	Al ₂ (SO ₄) ₃ · 14(H ₂ O)	
Ammonia		NH ₃	
Ammonium		NH ₄	
Bentonitic clay	Bentonite		
Calcium bicarbonate		Ca(HCO ₃) ₂	
Calcium carbonate	Limestone	CaCO ₃	
Calcium chloride		CaCl ₂	
Calcium Hypochlorite	HTH	Ca(OCl) ₂ · 4H ₂ O	
Calcium hydroxide	Slaked Lime	Ca(OH) ₂	
Calcium oxide	Unslaked (Quicklime)	CaO	
Calcium sulfate	Gypsum	CaSO ₄	
Carbon	Activated Carbon	C	
Carbon dioxide		CO ₂	
Carbonic acid		H ₂ CO ₃	
Chlorine gas		Cl ₂	
Chlorine Dioxide		ClO ₂	
Copper sulfate	Blue vitriol	CuSO ₄ · 5H ₂ O	
Dichloramine		NHCl ₂	
Ferric chloride	Iron chloride	FeCl ₃	
Ferric hydroxide		Fe(OH) ₃	
Ferric sulfate	Iron sulfate	Fe ₂ (SO ₄) ₃	
Ferrous bicarbonate		Fe(HCO ₃) ₂	
Ferrous hydroxide		Fe(OH) ₂	
Ferrous sulfate	Copperas	FeSO ₄ · 7H ₂ O	
Hydrofluorosilicic acid		H ₂ SiF ₆	
Hydrochloric acid	Muriatic acid	HCl	
Hydrogen sulfide		H ₂ S	

Chemical Name	Common Name	Chemical Formula	pH (Raise or Lowers)
Hypochlorous acid		HOCL	
Magnesium bicarbonate		Mg(HCO ₃) ₂	
Magnesium carbonate		MgCO ₃	
Magnesium chloride		MgCl ₂	
Magnesium hydroxide		Mg(OH) ₂	
Magnesium dioxide		MgO ₂	
Manganous bicarbonate		Mn(HCO ₃) ₂	
Manganous sulfate		MnSO ₄	
Monochloramine		NH ₂ Cl	
Potassium bicarbonate		KHCO ₃	
Potassium permanganate		KMnO ₄	
Sodium carbonate	Soda ash	Na ₂ CO ₃	
Sodium chloride	Salt	NaCl	
Sodium chlorite		NaClO ₂	
Sodium fluoride		NaF	
Sodium fluorsilicate		Na ₂ SiF ₆	
Sodium hydroxide	Lye	NaOH	
Sodium hypochlorite		NaOCl	
Sodium Metaphosphate	Hexametaphosphate	NaPO ₃	
Sodium phosphate	Disodium phosphate	Na ₃ PO ₄	
Sodium sulfate		Na ₂ SO ₄	
Sulfuric acid		H ₂ SO ₄	



Solubility of Substances in Water

Water is an excellent solvent for many compounds. Some dissolve in it as molecules while others, called electrolytes, dissociate and dissolve not as neutral molecules but as charged species called ions. Compounds which exist as solid ionic crystals dissolve in water as ions, and most of them are highly soluble in water. "Highly soluble" is a somewhat elastic description, but generally means soluble to at least the extent of forming 0.1 to 1.0 molar aqueous solutions. Salts which are less soluble in water than this at room temperature are called slightly soluble salts.

The solubility of an ionic salt depends both upon its cations and its anions, but for simple salts in aqueous solution at room temperature the following general observations are useful. Almost all sodium, potassium, and ammonium salts are highly soluble; the only significant exception is KClO_4 , which is moderately soluble almost without exception. Metal carbonates and phosphates are generally insoluble or slightly soluble, with the exception of those of sodium, potassium, and ammonium which are highly soluble; magnesium ammonium phosphate is used for the precipitation of magnesium ion.

Metal halides are generally highly soluble, with the exception of those of silver, lead, and mercury (I). Lead chloride is slightly soluble while silver and mercury (I) chlorides are much less soluble. Sulfate salts are generally highly soluble as well, with more exceptions; calcium, barium, strontium, lead, and mercury (I) sulfates are almost insoluble while silver sulfate is slightly soluble. Metal sulfides are generally insoluble in water.

Solid-Solution (Solubility) Reactions

When solids dissolve, the solutes are no longer pure substances and their activity can no longer be taken as unity. In dilute solutions, aqueous or otherwise, activities of solutes are often taken as equal to their molar concentrations. These equilibria are called solubility equilibria and are taken up under the following main heading. The example below shows how the form in which they are written compares to other equilibrium constants.

Example. The equilibrium constant for the reaction $\text{AgCl}(s) \rightleftharpoons \text{Ag}^+(aq) + \text{Cl}^-(aq)$ is written as $K = a(\text{Ag}^+)a(\text{Cl}^-)/a(\text{AgCl})$; more commonly, it is written in the form $K_a(\text{AgCl}) = a(\text{Ag}^+)a(\text{Cl}^-) = K_{sp}$. If the molar concentrations are taken as good approximations to the activities, which in dilute solutions they are, then $K_{sp} = [\text{Ag}^+][\text{Cl}^-]$.

Example. Let us write and simplify to the extent possible the equilibrium constant for the equilibrium $\text{Al}^{3+}(aq) + 3\text{OH}^-(aq) \rightleftharpoons \text{Al}(\text{OH})_3(s)$. For this equilibrium $K = 1/[\text{Al}^{3+}][\text{OH}^-]^3 = 1/K_{sp}$, where K has the units $\text{dm}^{12}/\text{mol}^4$, or $(\text{dm}^3)^4/\text{mol}^4$.

The form of equilibrium constant indicated as K_{sp} is called the solubility product constant or, more commonly, the solubility product. This constant therefore must refer to the process of a solid going into solution (solubility) rather than the reverse, precipitation of solid from solution. As a consequence, the ions are products and appear in the numerator.

The value of the solubility product is temperature-dependent and is generally found to increase with increasing temperature. As a consequence, the molar solubility of ionic salts generally increases with increasing temperature. The extent of this increase varies from one salt to another.

It is sometimes possible to take advantage of the difference in the effect of temperature to separate mixtures of different soluble salts. As the chart in the following Figure shows, a solution originally of equal concentration in KClO_3 and KNO_3 should upon heating and evaporation of water precipitate KClO_3 because KNO_3 is by far the more soluble near the boiling point of water.

The solubility of solid salts in water, and in most other solvents, increases with temperature while that of gases decreases. The heat or enthalpy change of the dissolution reaction for most solids is positive so the dissolution reaction is endothermic. For some solids, such as NaCl , the heat of solution is very small and so the effect of temperature is small also. For other salts, such as KNO_3 , the effect of temperature is much larger:

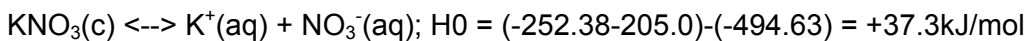
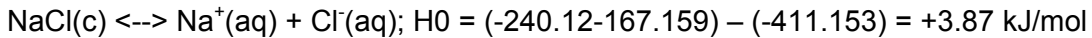

Chemical coagulation in the water/wastewater treatment is the process of bringing suspended matter in untreated water together for the purpose of settling and for the preparation of the water for filtration.

Coagulation involves three specific steps, which are:

- ◆ Coagulation
- ◆ Flocculation
- ◆ Sedimentation



Primary Clarifier

Purpose of Coagulation

Untreated surface waters contain clay, minerals, bacteria, inert solids, microbiological organisms, oxidized metals, organic color producing particles, and other suspended materials. Some of the microbiological organisms can include Giardia cysts, pathogenic bacteria, and viruses. Oxidized metals include iron and manganese. All of these materials can inhibit disinfection, cause problems in the distribution system, and leave the water cloudy rather than clear. The purpose of coagulation is to remove these particles.

The ability of particles to remain suspended in water is a function of both the particle size and specific gravity. Turbidity particles can range in size from molecular to 50 microns. Particles which are greater than one micron in diameter are considered silt, and settle out due to their relatively large size and density without the need to coagulate in a matter of seconds or minutes.

Colloidal material ranges in size from 0.001 to one micron in diameter. These materials require days to months for complete settling. Since detention times in the water treatment process are generally less than twelve hours, the rate of settling of these colloidal particles must be increased in the water treatment process. This is accomplished in the coagulation process when tiny particles agglomerate into larger, denser particles which will settle more quickly as shown in the picture on the right.

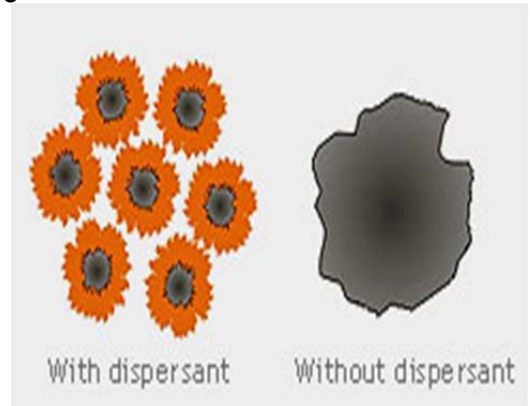

These tiny colloidal particles have a very large surface area to mass ratio, and this factor is important in keeping the particles suspended for long periods of time. In fact, the surface area to mass ratio is so high that electric charges and ionic groups become important in keeping the particles suspended. Two types of colloids exist. These are hydrophobic or water hating colloids, and hydrophilic or water loving colloids. Hydrophilic colloids form suspensions easily, and can be difficult to remove. These colloids can, however, react chemically with the coagulants commonly added to water under proper conditions. Examples of hydrophilic colloids would be organic color forming compounds. Hydrophobic colloids do not easily form suspensions. The reactions between hydrophobic colloids and the coagulants commonly added to water are largely physical rather than chemical. Examples of hydrophobic colloids would be clays and metal oxides.

The Coagulation Process

Coagulation is accomplished by the addition of ions having the opposite charge to that of the colloidal particles. Since the colloidal particles are almost always negatively charged, the ions which are added should be cations or positively charged. The coagulating power of an ion is dependent on its valency or magnitude of charge. A bivalent ion (+2 charge) is 30 to 60 times more effective than a monovalent ion (+1 charge). A trivalent ion (+3 charge) is 700 to 1000 times more effective than a monovalent ion.

Typically, two major types of coagulants are added to water. These are aluminum salts and iron salts. The most common aluminum salt is aluminum sulfate, or alum.

When aluminum sulfate is added to water, the aluminum ions enter into a series of complicated reactions. The aluminum ions become hydrated, meaning that water molecules attach themselves to the aluminum ions. In addition, anions present in the water, such as hydroxide and sulfate ions can attach to the aluminum ions.

These reactions result in large, positively charged molecules having aluminum ions at their center. These particles may have charges as high as +4. Following these reactions, a second type of reaction occurs, called Olation. This reaction involves the bridging of two or more of these large molecules to form even larger, positively charged ions. A typical molecule can contain eight aluminum ions, twenty hydroxide ions, and will have a +4 charge. Iron salts behave in a similar manner when added to water.

Once these large polymeric aluminum or iron compounds are formed, the magnitude of their high positive charge allows these species to rapidly move toward the colloid, where they are adsorbed onto the negatively charged surface of the turbidity particle. The coagulant compounds can penetrate the bound water layer because of their high positive charge.

This rapid adsorption results in the compression of the electrical double layer, and results in the colloid becoming coated with the coagulant compounds. The net result of this process is that the electrical charges on the particle are reduced. The suspension is now considered to be destabilized, and the particles can be brought together through, among other forces, Brownian Movement, and will be held together by the Van der Waals forces.

An additional process occurs which assists this process. As the coagulant continues to undergo the hydrolyzation and olation reactions, progressively larger masses of flocculent material are formed. These compounds can become large enough to settle on their own, and tend to trap turbidity particles as they settle. This is commonly referred to as sweep floc.

As the coagulation reactions and destabilization are occurring, the Zeta Potential at the surface of the colloid is also found to be reducing. Typically, the Zeta Potential for a naturally occurring water may be in the range of -10 to -25 millivolts. As the reactions occur, this Zeta Potential will be reduced to approximately -5 millivolts. These figures are only examples of what might be considered typical waters. Since all waters exhibit a specific set of characteristics, these numbers will vary. It is interesting to note that the Zeta Potential does not have to be reduced to zero in order for coagulation to occur, because the forces of attraction can become predominant before complete destabilization occurs.

Hydrophilic colloids participate in the coagulation process in a slightly different way. These colloids tend to attract water molecules and attach these water molecules to their surfaces. This is also a hydration process, and the water molecules act as a barrier to contact between particles. Also attached to the surfaces are hydroxyl, carboxyl, and phosphate groups, all to which are negatively charged. Coagulant products react chemically with the negatively charged groups attached to the hydrophilic colloids, forming an insoluble product which is electrically neutral and destabilized.

Factors Influencing Coagulation

Effects of pH: The pH range in which a coagulation process occurs may be the single most important factor in proper coagulation. The vast majority of coagulation problems are related to improper pH levels. Whenever possible, coagulation should be conducted in the optimum pH zone. When this is not done, lower coagulation efficiency results, generally resulting in a waste of chemicals and a lowered water quality. Each of the inorganic salt coagulants has its own characteristic optimum pH range. In many plants, it is necessary to adjust the pH level in the coagulation process. In most cases this involves the addition of lime, caustic soda, or soda ash to maintain a minimum pH level. In some cases, however, acids may be necessary to lower the pH level to an optimum range. In some water plants, the acidic reactions of the inorganic salts are taken advantage of when the raw water pH levels are higher than desired. In these instances, overfeed of the coagulant is intentionally induced in order for the coagulation process to occur in the optimum range.

Effects of salts: Since no natural waters are completely pure, each will have various levels of cations and anions such as calcium, sodium, magnesium, iron, manganese, sulfate, chloride, phosphate, and others. Some of these ions may affect the efficiency of the coagulation process. Generally, mono and divalent cations such as sodium, calcium, and magnesium have little or no effect on the coagulation process. Trivalent cations do not have an adverse effect on the process in most instances. In fact, significant concentrations of naturally occurring iron in a water supply has resulted in the ability to feed lower than normal dosages of inorganic salt coagulants.

Some anions can have a more pronounced effect. Generally, monovalent anions such as chloride have little effect on the coagulation process. As the concentration of the divalent anion sulfate in a water supply increases, the optimum pH range of the inorganic salt coagulants tends to broaden, generally toward the lower pH levels. As the concentration of phosphate ions increase, the optimum range of pH tends to shift to lower pH levels, without broadening. These effects could cause a disruption of the coagulation process if abrupt changes in the concentrations of these anions occur in the water supply.

Nature of turbidity: The turbidity in natural surface waters is composed of a large number of sizes of particles. The sizes of particles can be changing constantly, depending on precipitation and manmade factors. When heavy rains occur, runoff into streams, rivers, and reservoirs occurs, causing turbidity levels to increase. In most cases, the particle sizes are relatively large and settle relatively quickly in both the water treatment plant and the source of supply. However, in some instances, fine, colloidal material may be present in the supply, which may cause some difficulty in the coagulation process.

Generally, higher turbidity levels require higher coagulant dosages. However, seldom is the relationship between turbidity level and coagulant dosage linear. Usually, the additional coagulant required is relatively small when turbidities are much higher than normal due to higher collision probabilities of the colloids during high turbidities. Conversely, low turbidity waters can be very difficult to coagulate due to the difficulty in inducing collision between the colloids. In this instance, floc formation is poor, and much of the turbidity is carried directly to the filters. Organic colloids may be present in a water supply due to pollution, and these colloids can be difficult to remove in the coagulation process. In this situation, higher coagulant dosages are generally required.

Water temperature: Cold water temperatures can cause two factors which add to the difficulty of the coagulation process. As water temperatures approach freezing, almost all chemical reactions occur more slowly. It can be more difficult therefore to evenly disperse the coagulants into the water. As a result, the coagulant process becomes less efficient, and higher coagulant dosages are generally used to compensate for these effects. In addition, floc settling characteristics become poor due to the higher density of the water during near freezing temperatures.

Mixing Effects: Poor or inadequate mixing results in an uneven dispersion of the coagulant. Unfortunately, many older plants were designed with mixing facilities which generally do not accomplish mixing in the most efficient manner. As a result, it becomes necessary to use higher than necessary dosages of coagulant to achieve an optimum level of efficiency in the process. The effects of low turbidity and cold water temperatures can tend to aggravate the lack of adequate mixing facilities in some plants.

Effect of the coagulant: The choice of the proper coagulant for the given conditions is of critical importance in maintaining an efficient coagulation scheme under widely varying conditions. The chemicals most commonly used in the coagulation process are Aluminum Sulfate, Ferric Chloride, Ferric Sulfate, and Cationic Polymers.

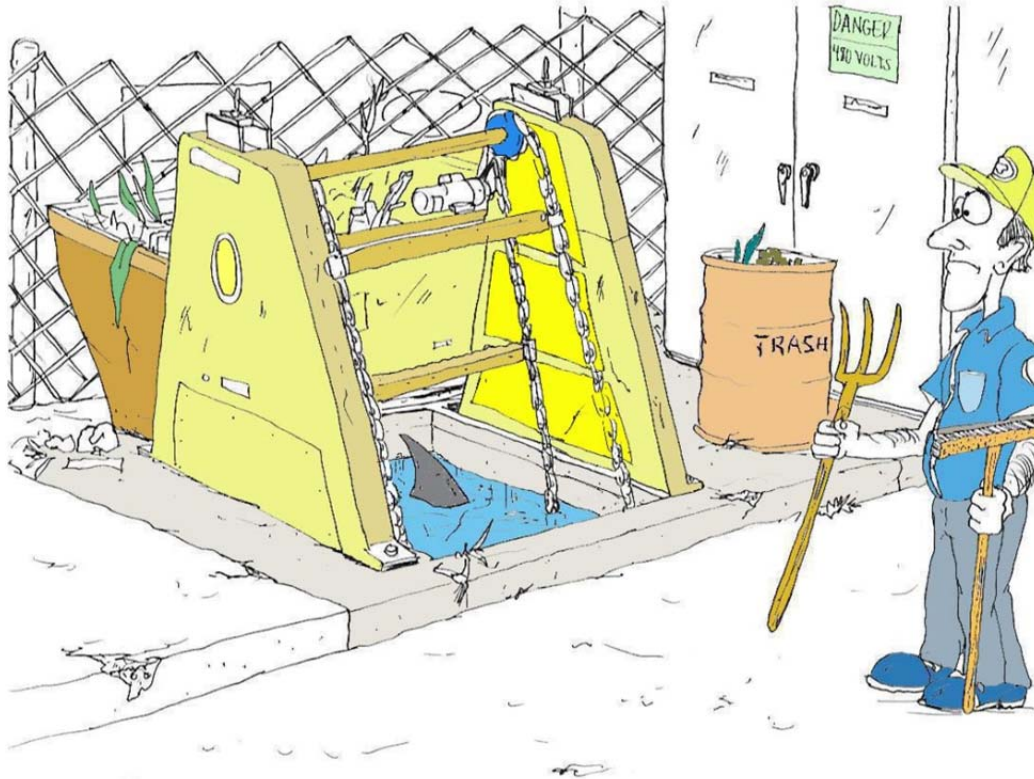

Coagulants

Aluminum Sulfate (Alum): Aluminum Sulfate is also known as alum, filter alum, and alumina sulfate. Alum is the most widely used coagulant. Alum is available in dry form as a powder or in lump form. It can also be purchased and fed as a liquid. Alum has no exact formula due to the varying water molecules of hydration which may be attached to the aluminum sulfate molecule. Once in water, alum can react with hydroxides, carbonates, bicarbonates, and other anions as discussed previously to form large, positively charged molecules. Carbon dioxide and sulfate are generally byproducts of these reactions. During the reactions, alum acts as an acid to reduce the pH and alkalinity of the water supply. It is important that sufficient alkalinity be present in the water supply for the various reactions to occur.

On a theoretical basis, 1.0 mg/l of dry alum will react with:

- 0.50 mg/l of natural alkalinity as calcium carbonate
- 0.33 mg/l of 85% quicklime as calcium oxide
- 0.39 mg/l of 95% hydrated lime as calcium hydroxide
- 0.54 mg/l of soda ash as sodium carbonate

Alum can be effective in the pH range of 5.5 to 7.8, but seems to work best in most water supplies in a pH range of 6.8 to 7.5. Below a pH range of 5.5, alkalinity in the water supply is generally insufficient. The aluminum ions become soluble rather than insoluble and do not participate in the hydration and olation reactions necessary to make the alum effective as a coagulant. In these instances the plant may experience higher than normal filtered water turbidities, and much of the aluminum will pass through the filters.

When the pH level of the water is above 7.8 after the addition of the alum, the aluminum ions again become soluble, and the efficiency of coagulation is decreased. Under these conditions, aluminum ions again penetrate the filters, and post filtration alum coagulation can occur in the clear well and in the distribution system in some cases.

Ferric Chloride (Ferric): Traditionally, ferric chloride has not been used widely as a coagulant, but this trend is not continuing. Ferric chloride is becoming more extensively used as a coagulant due partially to the fact that the material can be purchased as a liquid.

Ferric chloride may also be purchased as an anhydrous solid. Liquid ferric chloride is highly corrosive, and must be isolated from all corrodible metals. Like ferric sulfate, ferric chloride exhibits a wide pH range for coagulation, and the ferric ion does not easily become soluble. As a result, many plants are replacing alum with ferric chloride to eliminate the penetration of aluminum ions through the plant filters. Ferric chloride also reacts as an acid in water to reduce alkalinity.

Other inorganic coagulants are available, such as potash alum, ammonia alum, ferrous sulfate (copperas), and chlorinated copperas. None of these materials are widely used. Typical dosages of the inorganic coagulants range from 50 pounds per million gallons of water treated under ideal conditions to as high as 800 to 1000 pounds per million gallons of water treated under worst case conditions.

H₂S Control – Traditional Wet Scrubbing using Chemicals

The most common method of control of H₂S gas is to pass the smelly gas through a vertical, packed bed wet scrubber. The air passes up the tower as the scrubbing liquid containing caustic (NaOH) and oxidizing agent (most often bleach or NaOCl, sodium hypochlorite) flows down the tower in the counter-current fashion. The high pH provided by the caustic drives the mass transfer from gas to liquid phase by solubilizing H₂S as HS⁻ bisulfide and S⁻² sulfide ions. Once in solution, the reaction between hydrogen sulfide and oxidizing agent is almost instantaneous (assuming sufficient oxidizing agent is present). This reaction converts the sulfide to sulfate (SO₄⁻²) ion. The overall chemical reaction is described by the following equation:

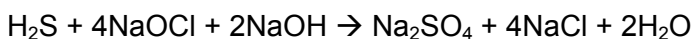

Therefore, theoretically, for each molecule of H₂S destroyed, four molecules of bleach and two molecules of caustic are consumed. However, the chemistry is not quite so simple, as partial oxidation of H₂S also takes place which forms elemental sulfur:

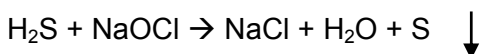

This reaction represents about 1% of the chemistry present in a wet scrubber. The presence of excess bleach helps to minimize the formation of elemental sulfur. But bleach is an expensive chemical. The use of two stage scrubbing is often employed both to minimize chemical consumption as well as to control sulfur deposits when scrubbing H₂S. The first stage operates at 80% efficiency and uses a caustic only scrub at high pH (12.5). The air then passes to the second stage, where the remaining H₂S is scrubbed with caustic / bleach solution at pH 9.5. The H₂S present is destroyed at 99%+ efficiency. The blowdown from the 2nd stage, which will contain some amount of unused NaOCl, is sent to the sump of the 1st stage. In this way additional H₂S is destroyed and maximum consumption of expensive oxidizing agent is assured.

Never the less, there are losses of chemicals which cannot be prevented, which of course raise the cost of odor scrubbing. These losses are due to the facts that bleach, NaOCl, slowly decomposes in storage as well as the fact that some amount of caustic is constantly lost to CO₂ absorption in both scrubbing stages.

Emissions

Volatile organic compounds (VOCs) are the primary air pollutants emitted from rendering operations. The major constituents that have been qualitatively identified as potential emissions include organic sulfides, disulfides, C-4 to C-7 aldehydes, trimethylamine, C-4 amines, quinoline, dimethyl pyrazine, other pyrazines, and C-3 to C-6 organic acids. In addition, lesser amounts of C-4 to C-7 alcohols, ketones, aliphatic hydrocarbons, and aromatic compounds are potentially emitted. No quantitative emission data were presented. Historically, the VOCs are considered an odor nuisance in residential areas in close proximity to rendering plants, and emission controls are directed toward odor elimination. The odor detection threshold for many of these compounds is low; some as low as 1 part per billion (ppb). Of the specific constituents listed, only quinoline is classified as a hazardous air pollutant (HAP). In addition to emissions from rendering operations, VOCs may be emitted from the boilers used to generate steam for the operation.

Hard Water Section

Water contains various amounts of dissolved minerals, some of which impart a quality known as hardness. Consumers frequently complain about problems attributed to hard water, such as the formation of scale on cooking utensils and hot water heaters. In this document we will examine the occurrence, and effects, of hard water and the hard water treatment or softening process that removes the hardness-causing minerals. The precipitation process most frequently used is generally known as the lime process or lime soda process. Because of the special facilities required and the complexity of the process, it is generally applicable only to medium- or large-size water systems where all treatment can be accomplished at a central location. This process will provide softened water at the lowest cost. Lime softening can be used for treatment of either groundwater or surface water sources.

The other commonly used method of softening involves the ion exchange process. This process has the advantages of a considerably lower initial cost and ease of use by small systems or by large systems at multiple locations. The principal disadvantage is that operating costs are considerably higher. Ion exchange processes can typically be used for direct treatment of groundwater, so long as turbidity and iron levels are not excessive. For treatment of surface water, the process normally must be preceded by conventional treatment. Softening can also be accomplished using membrane technology, electrodialysis, distillation, and freezing. Of these, membrane methods seem to have the greatest potential.



Distillers

Various sizes of distillers are available for home use. They all work on the principle of vaporizing water and then condensing the vapor. In the process, dissolved solids such as salt, metals, minerals, asbestos fibers, and other particles are removed. Some organic chemicals are also removed, but those that are more volatile are often vaporized and condensed with the product water. Distillers are effective in killing all microorganisms.

The principal problem with a distiller is that a small unit can produce only 2-3 gal (7.5 -11 Lt) a day, and that the power cost for operation will be substantially higher than the operating cost of other types of treatment devices.

Water Distillers have a high energy cost (approximately 20-30 cents per gallon). They must be carbon filtered before and/or after to remove volatile chemicals. It is considered "**dead**" water because the process removes all extra oxygen and energy. It has no taste. It is still second only to reverse osmosis water for health. Diet should be rich in electrolytes, as the aggressive nature of distilled water can "**leach**" electrolytes from the body.



Occurrence of Hard Water

Hard water is caused by soluble, divalent, metallic cations, (positive ions having valence of 2). The principal chemicals that cause water hardness are calcium (**Ca**) and magnesium (**Mg**). Strontium, aluminum, barium, and iron are usually present in large enough concentrations to contribute significantly to the total hardness.

Water hardness varies considerably in different geographic areas of the contiguous 48 states. This is due to different geologic formations, and is also a function of the contact time between water and limestone deposits. Magnesium is dissolved as water passes over and through dolomite and other magnesium-bearing minerals. Because groundwater is in contact with these formations for a longer period of time than surface water, groundwater is normally harder than surface water.

Expressing Water Hardness Concentration

Water hardness is generally expressed as a concentration of calcium carbonate, in terms of milligrams per liter as CaCO_3 . The degree of hardness that consumers consider objectionable will vary, depending on other qualities of the water and on the hardness to which they have become accustomed. We will show two different classifications of the relative hardness of water:

Comparative classifications of water for softness and hardness

Classification	mg/L as CaCO_3 *	mg/L as CaCO_3 +
Soft	0 – 75	0 – 60
Moderately hard	75 – 150	61 – 120
Hard	150 – 300	121 – 180
Very hard	Over 300	Over 180

Source: Adapted from Sawyer 1960 and Briggs and Ficke 1977.

* Per Sawyer (1960)

+ Per Briggs and Ficke (1977)

Types of Water Hardness

Hardness can be categorized by either of two methods: calcium versus magnesium hardness and carbonate versus non-carbonate hardness. The calcium-magnesium distinction is based on the minerals involved. Hardness caused by calcium is called calcium hardness, regardless of the salts associated with it, which include calcium sulfate (**CaSO₄**), calcium chloride (**CaCl₂**), and others. Likewise, hardness caused by magnesium is called magnesium hardness. Calcium and magnesium are normally the only significant minerals that cause hardness, so it is generally assumed that

$$\text{Total hardness} = \text{calcium hardness} + \text{magnesium hardness}$$

The carbonate-noncarbonate distinction, however, is based on hardness from either the bicarbonate salts of calcium or the normal salts of calcium and magnesium involved in causing water hardness. Carbonate hardness is caused primarily by the bicarbonate salts of calcium and magnesium, which are calcium bicarbonate, $\text{Ca}(\text{HCO}_3)_2$, and magnesium bicarbonate $\text{Mg}(\text{HCO}_3)_2$. Calcium and magnesium combined with carbonate (CO_3) also contribute to carbonate hardness.

Noncarbonate hardness is a measure of calcium and magnesium salts other than carbonate and bicarbonate salts. These salts are calcium sulfate, calcium chloride, magnesium sulfate (MgSO_4), and magnesium chloride (MgCl_2). Calcium and magnesium combined with nitrate may also contribute to noncarbonate hardness, although it is a very rare condition. For carbonate and noncarbonate hardness,

$$\text{Total hardness} = \text{carbonate hardness} + \text{noncarbonate hardness}$$

When hard water is boiled, carbon dioxide (CO_2) is driven off, and Bicarbonate salts of calcium and magnesium then settle out of the water to form calcium and magnesium carbonate precipitates. These precipitates form the familiar chalky deposits on teapots. Because it can be removed by heating, carbonate hardness is sometimes called "**Temporary hardness.**" Because noncarbonated hardness cannot be removed or precipitated by prolonged boiling, it is sometimes called "**permanent hardness.**"

Objections to Hard Water

Scale Formation

Hard water forms scale, usually calcium carbonate, which causes a variety of problems. Left to dry on the surface of glassware and plumbing fixtures, including showers doors, faucets, and sink tops; hard water leaves unsightly white scale known as water spots. Scale that forms on the inside of water pipes will eventually reduce the flow capacity or possibly block it entirely. Scale that forms within appliances and water meters causes wear on moving parts.

When hard water is heated, scale forms much faster. In particular, when the magnesium hardness is more than about 40 mg/l (as CaCO_3), magnesium hydroxide scale will deposit in hot water heaters that are operated at normal temperatures of 140-150°F (60-66°C). A coating of only 0.04 in. (1 mm) of scale on the heating surfaces of a hot water heater creates an insulation effect that will increase heating costs by about 10 percent.



Effect on Soap

The historical objection to hardness has been its effect on soap. Hardness ions form precipitates with soap, causing unsightly "**curd,**" such as the familiar bathtub ring, as well as reduced efficiency in washing and laundering. To counteract these problems, synthetic detergents have been developed and are now used almost exclusively for washing clothes and dishes.

These detergents have additives known as sequestering agents that "**tie up**" the hardness ions so that they cannot form the troublesome precipitates. Although modern detergents counteract many of the problems of hard water, many customers prefer softer water. These customers can install individual softening units or use water from another source, such as a cistern, for washing.

Water Softening

Water softening is a method of removing from water the minerals that make it hard. Hard water does not dissolve soap readily. It forms scale in pipes, boilers, and other equipment in which it is used. The principal methods of softening water are the lime soda process and the ion exchange process.

In the **lime soda process**, soda ash and lime are added to the water in amounts determined by chemical tests. These chemicals combine with the calcium and magnesium in the water to make insoluble compounds that settle to the bottom of the water tank.

In the **ion exchange process**, the water filters through minerals called **zeolites**. As the water passes through the filter, the sodium ions in the zeolite are exchanged for the calcium and magnesium ions in the water, and the water is softened. After household softeners become exhausted, a strong solution of **sodium chloride** (salt) is passed through the filter to replace the sodium that has been lost.

The use of two exchange materials makes it possible to remove both metal and acid ions from water. Some cities and towns, however, prohibit or restrict the use of ion exchange equipment on drinking water, pending the results of studies on how people are affected by the consumption of the added sodium in softened water. The containers hold the resin for the deionization. Calcium and magnesium in water create hard water, and high levels can clog pipes. The best way to soften water is to use a water softener unit connected into the water supply line. You may want to consider installing a separate faucet for unsoftened water for drinking and cooking. Water softening units also remove iron.



The most common way to soften household water is to use a water softener. Softeners may also be safely used to remove up to about 5 milligrams per liter of dissolved iron if the water softener is rated for that amount of iron removal. Softeners are automatic, semi-automatic, or manual. Each type is available in several sizes and is rated on the amount of hardness it can remove before regeneration is necessary. Using a softener to remove iron in naturally soft water is not advised; a green-sand filter is a better method. When the resin is filled to capacity, it must be recharged. Fully automatic softeners regenerate on a preset schedule and return to service automatically. Regeneration is usually started by a preset time clock; some units are started by water use meters or hardness detectors.

Semi-automatic softeners have automatic controls for everything except for the start of regeneration. Manual units require manual operation of one or more valves to control back washing, brining and rinsing. In many areas, there are companies that provide a water softening service. For a monthly fee the company installs a softener unit and replaces it periodically with a freshly charged unit.



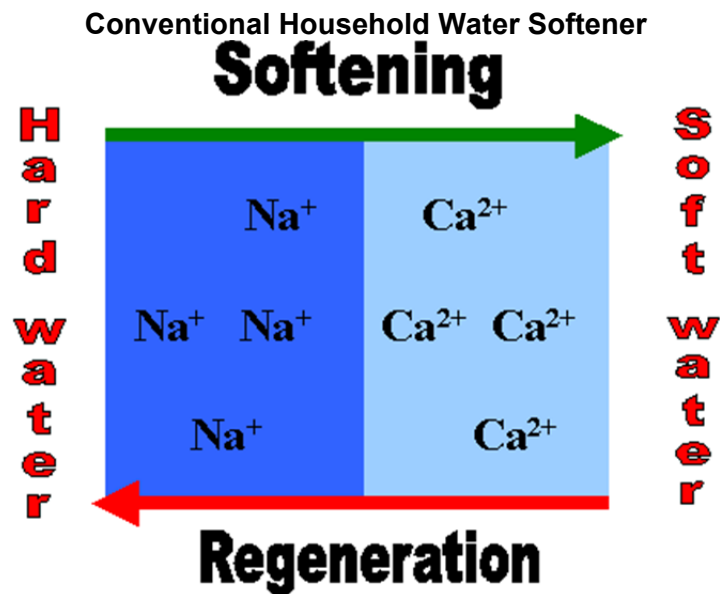
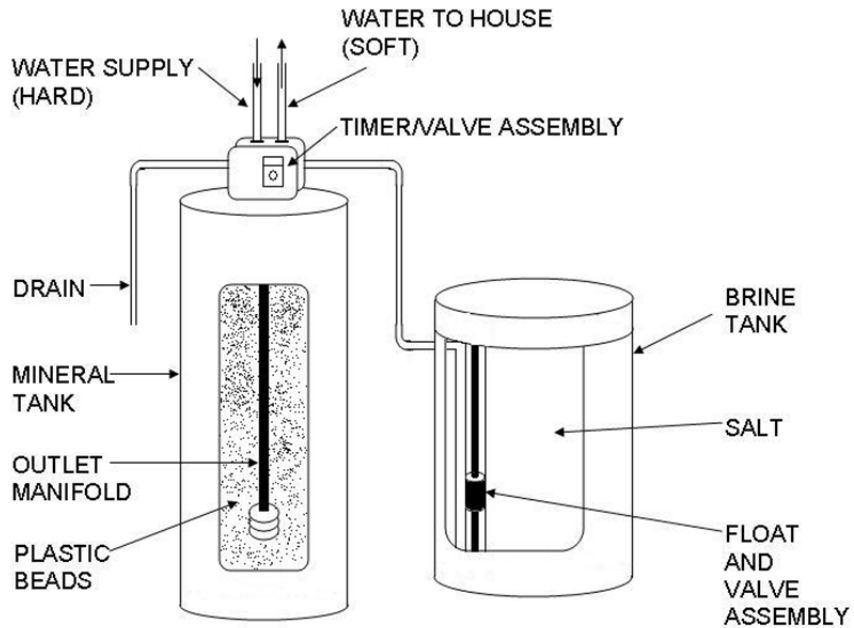

The principle behind water softening is really just simple chemistry. A water softener contains resin beads which hold electrically charged ions. When hard water passes through the softener, calcium and magnesium ions are attracted to the charged resin beads. It's the resulting removal of calcium and magnesium ions that produces "**soft water**."

The diagram shows the exchange that takes place during the water softening process. When the resin beads in your softener become saturated with calcium and magnesium ions, they need to be recharged. Sodium ions from the water softening salt reactivate the resin beads so they can continue to do their job. Without sufficient softening salt, your water softener is less efficient. As a rule, you should check your water softener once a week to be sure the salt level is always at least one quarter full.

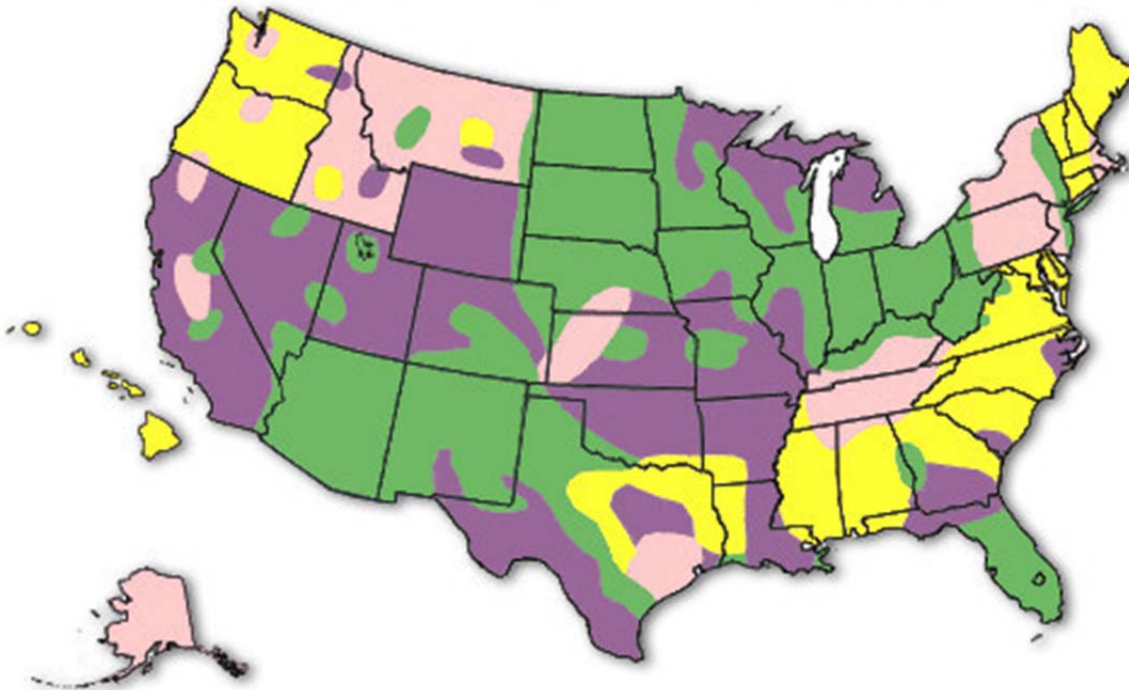

HARD WATER LEVELS THROUGHOUT THE U.S.



LEGEND	
	0 - 3.5 grains per gallon – Soft
	3.5 - 7.0 grains per gallon – Moderately Hard
	7.0 - 10.5 grains per gallon – Hard
	over 10.5 grains per gallon – Very Hard

Due to the nature of the water bed sub-soil structure, water hardness may vary from one source to another within a general area.

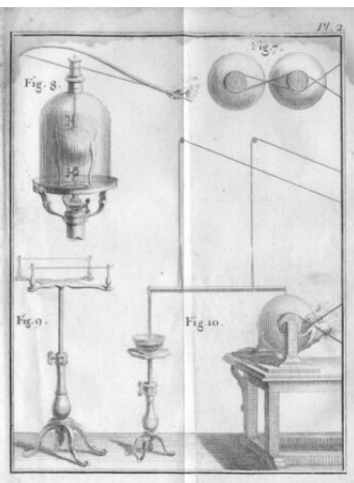

French physicist Nollet and his first RO unit.

Membrane Filtration Processes

In 1748, the French physicist Nollet first noted that water would diffuse through a pig bladder membrane into alcohol. This was the discovery of osmosis, a process in which water from a dilute solution will naturally pass through a porous membrane into a concentrate solution. Over the years, scientists have attempted to develop a membrane that would be useful in industrial processes, but it wasn't until the late 1950s that membranes were produced that could be used for what is known as reverse osmosis. In reverse osmosis, water is forced to move through a membrane from a concentrate solution to a dilute solution.

Since that time, continual improvements and new developments have been made in membrane technology, resulting in ever-increasing uses in many industries. In potable water treatment, membranes have been used for desalinization, removal of dissolved inorganic and organic chemicals, water softening, and removal of the fine solids.

In particular, membrane technology enables some water systems having contaminated water sources to meet new, more stringent regulations. In some cases, it can also allow secondary sources, such as brackish groundwater, to be used. There is great potential for the continuing wide use of membrane filtration processes in potable water treatment, especially as technology is improved and costs are reduced.

Description of Membrane Filtration Processes

In the simplest membrane processes, water is forced through a porous membrane under pressure, while suspended solids, large molecules, or ions are held back or rejected.

Types of Membrane Filtration Processes

The two general classes of membrane processes, based on the driving force used to make the process work, are:

- Pressure-driven processes
- Electric-driven processes

Pressure-Driven Processes

The four general membrane processes that operate by applying pressure to the raw water are:

- Microfiltration
- Ultrafiltration
- Nanofiltration
- Reverse Osmosis



Microfiltration

Microfiltration (**MF**) is a process in which water is forced under pressure through a porous membrane. Membranes with a pore size of 0.45 μm are normally used; this size is relatively large compared with the other membrane filtration processes. This process has not been generally applicable to drinking water treatment because it either does not remove substances that require removal from potable water, or the problem substances can be removed more economically using other processes.

The current primary use of MF is by industries to remove very fine particles from process water, such as in electronic manufacturing. In addition, the process has also been used as a pretreatment for other membrane processes. In particular, Reverse Osmosis (**RO**) membranes are susceptible to clogging or binding unless the water being processed is already quite clean.

However, in recent years, microfiltration has been proposed as a filtering method for particles resulting from the direct filtration process. Traditionally, this direct filtration process has used the injection of coagulants such as alum or polymers into the raw water stream to remove turbidity such as clay or silts. The formed particles were then removed by rapid sand filters. Their suggested use is to improve filtering efficiency, especially for small particles that could contain bacterial and protozoan life.

Ultrafiltration

Ultrafiltration (**UF**) is a process that uses a membrane with a pore size generally below 0.1 μm . The smaller pore size is designed to remove colloids and substances that have larger molecules, which are called high-molecular-weight materials. UF membranes can be designed to pass material that weigh less than or equal to a certain molecular weight. This weight is called the molecular weight cutoff (**MWC**) of the membrane. Although UF does not generally work well for removal of salt or dissolved solids, it can be used effectively for removal of most organic chemicals.

Nanofiltration

Nanofiltration (**NF**) is a process using membrane that will reject even smaller molecules than UF. The process has been used primarily for water softening and reduction of total dissolved solids (**TDS**). NF operates with less pressure than reverse osmosis and is still able to remove a significant proportion of inorganic and organic molecules. This capability will undoubtedly increase the use of NF for potable water treatment.

Reverse Osmosis

Reverse Osmosis (**RO**) is a membrane process that has the highest rejection capability of all the membrane processes. These RO membranes have very low pore size that can reject ions at very high rates, including chloride and sodium. Water from this process is very pure due to the high reject rates. The process has been used primarily in the water industry for desalinization of seawater because the capital and operating costs are competitive with other processes for this service.

The RO also works for most organic chemicals, radionuclides and microorganisms. For industrial water uses such as semiconductor manufacturing, is also an important RO process. RO is discussed in more detail later.

Membrane Configurations

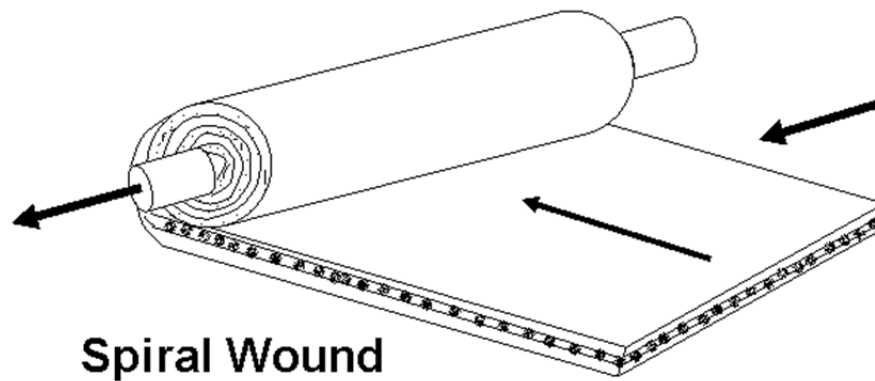
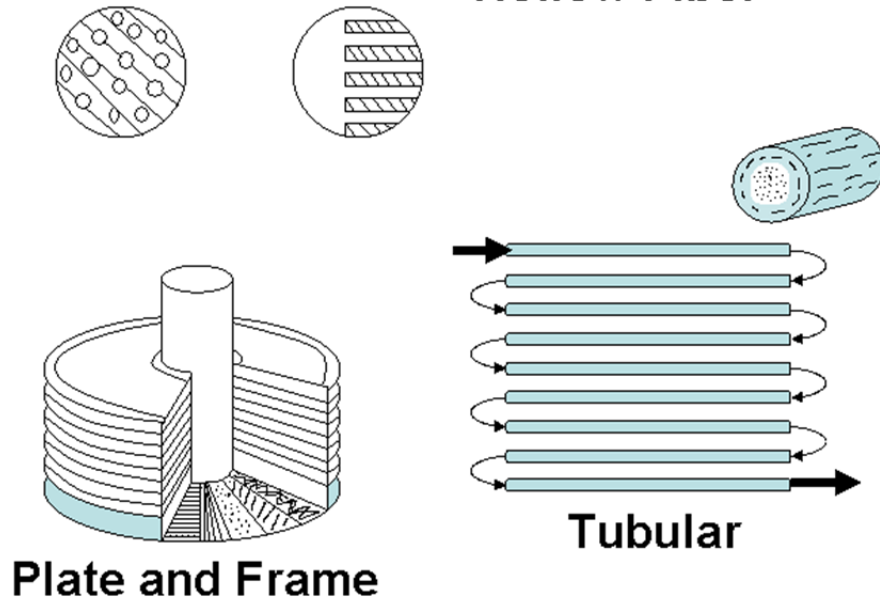
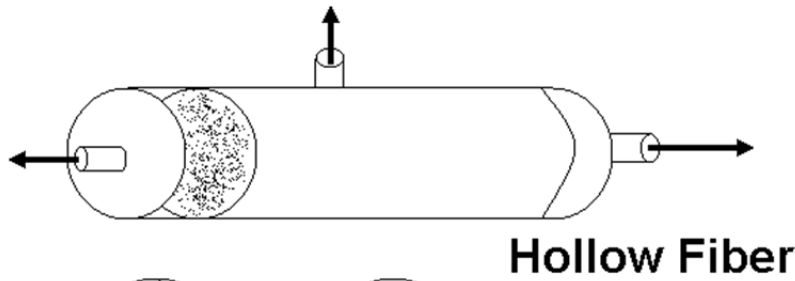

Electric-Driven Processes

There are two membrane processes that purify a water stream by using an electric current to move ions across a membrane.

These processes are

- **Electrodialysis**
- **Electrodialysis Reversal**

Electrodialysis

Electrodialysis (**ED**) is a process in which ions are transferred through a membrane as a result of direct electric current applied to the solution. The current carries the ions through a membrane from the less concentrated solution to the more concentrated one.

Electrodialysis Reversal

Electrodialysis Reversal (**EDR**) is a process similar to ED, except that the polarity of the direct current is periodically reversed. The reversal in polarity reverses the flow of ions between demineralizing compartments, which provides automatic flushing of scale-forming materials from the membrane surface.

As a result, EDR can often be used with little or no pretreatment of feedwater to prevent fouling. So far, ED and EDR have been used at only a few locations for drinking water treatment.



GAC inside Carbon vessels like these are often used for taste and odor control.

Reverse Osmosis

Osmosis is a natural phenomenon in which a liquid - water in this case - passes through a semi-permeable membrane from a relatively dilute solution toward a more concentrated solution. This flow produces a measurable pressure, called osmotic pressure.

If pressure is applied to the more concentrated solution, and if that pressure exceeds the osmotic pressure, water flows through the membrane from the more concentrated solution toward the dilute solution. This process, called reverse osmosis, or RO, removes up to 98% of dissolved minerals, and virtually 100% of colloidal and suspended matter. RO produces high quality water at low cost compared to other purification processes.

The membrane must be physically strong to stand up to high osmotic pressure - in the case of sea water, 2500 kg/m. Most membranes are made of cellulose acetate or polyamide composites cast into a thin film, either as a sheet or fine hollow fibers.

The membrane is constructed into a cartridge called a reverse osmosis module.

RO Skid



After filtration to remove suspended particles, incoming water is pressurized with a pump to 200 - 400 psi (1380 - 2760 kPa) depending on the RO system model.

This exceeds the water's osmotic pressure. A portion of the water (**permeate**) diffuses through the membrane, leaving dissolved salts and other contaminants behind with the remaining water where they are sent to drain as waste (**concentrate**).

RO

Pretreatment is important because it influences permeate quality and quantity. It also affects the module's life because many water-borne contaminants can deposit on the membrane and foul it. Generally, the need for pretreatment increases as systems become larger and operate at higher pressures, and as permeate quality requirements become more demanding. Because reverse osmosis is the principal membrane filtration process used in water treatment, it is described here in greater detail.

To understand Reverse Osmosis, one must begin by understanding the process of osmosis, which occurs in nature. In living things, osmosis is frequently seen. The component parts include a pure or relatively pure water solution and a saline or contaminated water solution, separated by a semi-permeable membrane, and a container or transport mechanism of some type.

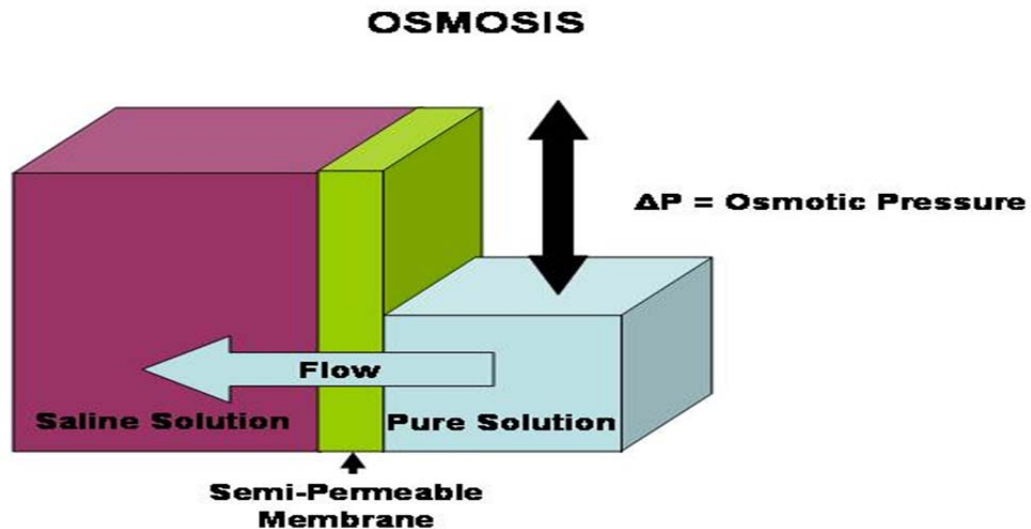

The semi-permeable membrane is so designated because it permits certain elements to pass through, while blocking others. The elements that pass through include water, usually smaller molecules of dissolved solids, and most gases. The dissolved solids are usually further restricted based on their respective electrical charge. In osmosis, naturally occurring in living things, the pure solution passes through the membrane until the osmotic pressure becomes equalized, at which point osmosis ceases. The osmotic pressure is defined as the pressure differential required to stop osmosis from occurring. This pressure differential is determined by the total dissolved solids content of the saline solution, or contaminated solution on one side of the membrane. The higher the content of dissolved solids, the higher the osmotic pressure. Each element that may be dissolved in the solution contributes to the osmotic pressure, in that the molecular weight of the element affects the osmotic pressure.

Generally, higher molecular weights result in higher osmotic pressures. Hence, the formula for calculating osmotic pressure is very complex. However, approximate osmotic pressures are usually sufficient to design a system. Common tap water, as found in most areas, may have an osmotic pressure of about 10 PSI (Pounds per Square Inch), or about 1.68 Bar. Seawater at 36,000 PPM typically has an osmotic pressure of about 376 PSI (26.75 Bar). Thus, to reach the point at which osmosis stops for tap water, a pressure of 10 PSI would have to be applied to the saline solution. To stop osmosis in seawater, a pressure of 376 PSI would have to be applied to the seawater side of the membrane. Several decades ago, U.S. Government scientists had the idea that the principles of osmosis could be harnessed to purify water from various sources, including brackish water and seawater. In order to transform this process into one that purifies water, osmosis would have to be reversed, and suitable synthetic membrane materials would have to be developed. Additionally, ways of configuring the membranes would have to be engineered to handle a continuous flow of raw and processed water without clogging or scaling the membrane material.

These ideas were crystallized and, fueled by U.S. Government funding, usable membrane materials and designs resulted. One of the membrane designs was the spiral wound membrane element. This design enabled the engineers to construct a membrane element that could contain a generous amount of membrane area in a small package, and to permit the flow of raw water to pass along the length of the membrane.

This permits flows and pressures to be developed to the point that ample processed or purified water is produced, while keeping the membrane surface relatively free from particulate, colloidal, bacteriological or mineralogical fouling.

The design features a perforated tube in the center of the element, called the product or permeate tube. Wound around this tube are one or more "**envelopes**" of membrane material, opening at the permeate tube. Each envelope is sealed at the incoming and exiting edge. Thus, when water penetrates or permeates through the membrane, it travels, aided by a fine mesh called the permeate channel, around the spiral and collects in the permeate tube. The permeate or product water is collected from the end of each membrane element, and becomes the product or result of the purification process.

Meanwhile, as the raw water flows along the "**brine channel**" or coarse medium provided to facilitate good flow characteristics, it gets more and more concentrated. This concentrated raw water is called the reject stream or concentrate stream. It may also be called brine if it is coming from a salt water source. The concentrate, when sufficient flows are maintained, serves to carry away the impurities removed by the membrane, thus keeping the membrane surface clean and functional. This is important, as buildup on the membrane surface, called fouling, impedes or even prevents the purification process.

The membrane material itself is a special thin film composite (**TFC**) polyamide material, cast in a microscopically thin layer on another, thicker cast layer of Polysulfone, called the microporous support layer. The microporous support layer is cast on sheets of paper-like material that are made from synthetic fibers such as polyester, and manufactured to the required tolerances.

Each sheet of membrane material is inspected at special light tables to ensure the quality of the membrane coating, before being assembled into the spiral wound element design. To achieve Reverse Osmosis, the osmotic pressure must be exceeded, and to produce a reasonable amount of purified water, the osmotic pressure is generally doubled. Thus with seawater osmotic pressure of 376 PSI, a typical system operating pressure is about 800 PSI.

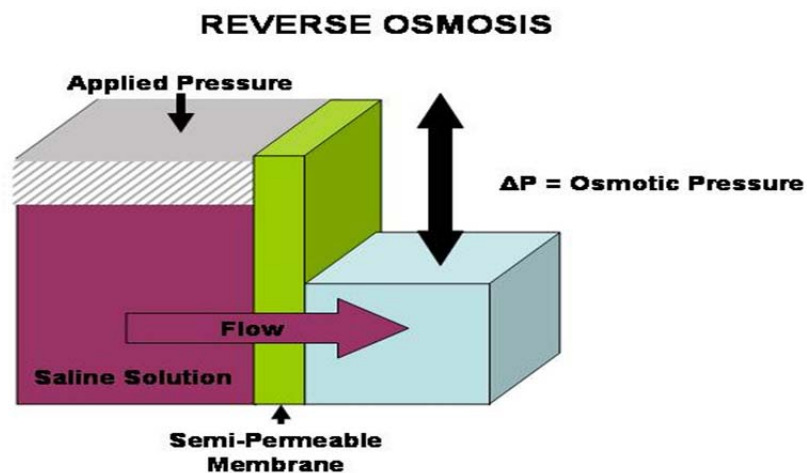

Factors that affect the pressure required include raw water temperature, raw water TDS (**Total Dissolved Solids**), membrane age, and membrane fouling.

The effect of temperature is that with higher temperatures, the salt passage increases, flux (permeate flow) increases, and operating pressure required is lower. With lower temperatures, the inverse occurs, in that salt passage decreases (reducing the TDS in the permeate or product water), while operating pressures increase. Or, if operating pressures do not increase, then the amount of permeate or product water is reduced. In general, Reverse Osmosis (**R/O**) systems are designed for raw water temperatures of 25° C (77° F). Higher temperatures or lower temperatures can be accommodated with appropriate adjustments in the system design.

Membranes are available in "**standard rejection**" or "**high rejection**" models for seawater and brackish water. The rejection rate is the percentage of dissolved solids rejected, or prevented from passing through the membrane. For example, a membrane with a rejection rate of 99% (usually based on Na (**Sodium**)) will allow only 1% of the concentration of dissolved solids to pass through into the permeate. Hence, product water from a source containing 10,000 PPM would have 100 PPM remaining. Of course, as the raw water is processed, the concentrations of TDS increase as it passes along the membrane's length, and usually multiple membranes are employed, with each membrane in the series seeing progressively higher dissolved solids levels.

Typically, starting with seawater of 36,000 PPM, standard rejection membranes produce permeate below 500 PPM, while high rejection membranes under the same conditions produce drinking water TDS of below 300 PPM. There are many considerations when designing R/O systems that competent engineers are aware of. These include optimum flows and pressures, optimum recovery rates (the percentage of permeate from a given stream of raw water), prefiltration and other pretreatment considerations, and so forth. Membrane systems in general cannot handle the typical load of particulate contaminants without prefiltration. Often, well designed systems employ multiple stages of prefiltration, tailored to the application, including multi-media filtration and one or more stages of cartridge filtration. Usually the last stage would be 5m or smaller, to provide sufficient protection for the membranes.

R/O systems typically have the following components:

A supply pump or pressurized raw water supply; prefiltration in one or more stages; chemical injection of one or more pretreatment agents may be added; a pressure pump suited to the application, sized and driven appropriately for the flow and pressure required; a membrane array including one or more membranes installed in one or more pressure tubes (also called pressure vessels, R/O pressure vessels, or similar); various gauges and flow meters; a pressure regulating valve, relief valve(s) and/or safety pressure switches; and possibly some form of post treatment. Post treatment should usually include a form of sterilization such as Chlorine, Bromine, Ultra-Violet (**U-V**), or Ozone. Other types of post treatment may include carbon filters, pH adjustment, or mineral injection for some applications.

Right side-Packaged treatment skid instrumentation, UV, and softening.



Granular Activated Carbon / Powdered Activated Carbon

Along with aeration, granular activated carbon (**GAC**) and powdered activated carbon (**PAC**) are suitable treatments for removal of organic contaminants such as VOCs, solvents, PCBs, herbicides and pesticides. Activated carbon is carbon that has been exposed to a very high temperature, creating a vast network of pores with a very large internal surface area; one gram of activated carbon has a surface area equivalent to that of a football field. It removes contaminants through adsorption, a process in which dissolved contaminants adhere to the surface of the carbon particles.

GAC can be used as a replacement for existing media (such as sand) in a conventional filter or it can be used in a separate contactor such as a vertical steel pressure vessel used to hold the activated carbon bed. After a period of a few months or years, depending on the concentration of the contaminants, the surface of the pores in the GAC can no longer adsorb contaminants and the carbon must be replaced. Several operational and maintenance factors affect the performance of granular activated carbon. Contaminants in the water can occupy adsorption sites, whether or not they are targeted for removal. Also, adsorbed contaminants can be replaced by other contaminants with which GAC has a greater affinity, so their presence might interfere with removal of contaminants of concern.

A significant drop in the contaminant level in influent water can cause a GAC filter to desorb, or slough off adsorbed contaminants, because GAC is essentially an equilibrium process. As a result, raw water with frequently changing contaminant levels can result in treated water of unpredictable quality. Bacterial growth on the carbon is another potential problem. Excessive bacterial growth may cause clogging and higher bacterial counts in the treated water. The disinfection process must be carefully monitored in order to avoid this problem.

Powdered activated carbon consists of finely ground particles and exhibits the same adsorptive properties as the granular form. PAC is normally applied to the water in a slurry and then filtered out. The addition of PAC can improve the organic removal effectiveness of conventional treatment processes and also remove tastes and odors. The advantages of PAC are that it can be used on a short-term or emergency basis with conventional treatment, it creates no headloss, it does not encourage microbial growth, and it has relatively small capital costs. The main disadvantage is that some contaminants require large doses of PAC for removal. It is also somewhat ineffective in removing natural organic matter due to the competition from other contaminants for surface adsorption and the limited contact time between the water and the carbon.

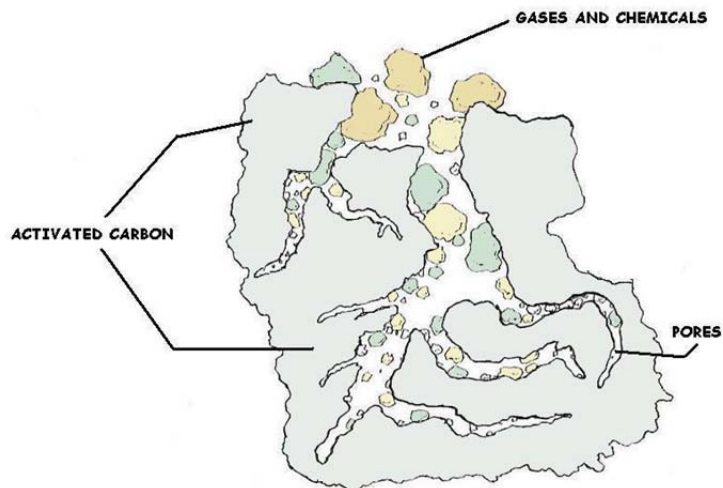

ACTIVATED CARBON ABSORBS GASES AND CHEMICALS

Clean-In-Place

Some very low cost R/O systems may dispense with most of the controls and instruments. However, systems installed in critical applications should be equipped with a permeate or product flow meter, a reject, concentrate or brine flow meter; multiple pressure gauges to indicate the pressure before and after each filtration device, and the system operation pressure in the membrane loop; preferably both before and after the membrane array. Another feature found in better systems is a provision to clean the membranes in place, commonly known as a "**Clean In Place**" (CIP) system. Such a system may be built right into the R/O system or may be provided as an attachment for use as required.

Reverse Osmosis has proven to be the most reliable and cost effective method of desalinating water, and hence its use has become more and more widespread. Energy consumption is usually some 70% less than for comparable evaporation technologies. Advancements have been made in membrane technology, resulting in stable, long-lived membrane elements. Component parts have been improved as well, reducing maintenance and down time. Additional advancements in pretreatment have been made in recent years, further extending membrane life and improving performance.

Reverse Osmosis delivers product water or permeate having essentially the same temperature as the raw water source (an increase of 1° C or 1.8° F may occur due to pumping and friction in the piping). This is more desirable than the hot water produced by evaporation technologies. R/O Systems can be designed to deliver virtually any required product water quality. For these and other reasons, R/O is usually the preferred method of desalination today.

Reverse osmosis, also known as hyperfiltration, is the finest filtration known. This process will allow the removal of particles as small as ions from a solution. Reverse osmosis is used to purify water and remove salts and other impurities in order to improve the color, taste, or properties of the fluid. It can be used to purify fluids such as ethanol and glycol, which will pass through the reverse osmosis membrane, while rejecting other ions and contaminants from passing. The most common use for reverse osmosis is in purifying water. It is used to produce water that meets the most demanding specifications that are currently in place.

Reverse osmosis uses a membrane that is semi-permeable, allowing the fluid that is being purified to pass through it, while rejecting the contaminants that remain. Most reverse osmosis technology uses a process known as cross-flow to allow the membrane to continually clean itself. As some of the fluid passes through the membrane the rest continues downstream, sweeping the rejected species away from the membrane. The process of reverse osmosis requires a driving force to push the fluid through the membrane, and the most common force is pressure from a pump. The higher the pressure, the larger the driving force. As the concentration of the fluid being rejected increases, the driving force required to continue concentrating the fluid increases.

Reverse osmosis is capable of rejecting bacteria, salts, sugars, proteins, particles, dyes, and other constituents that have a molecular weight of greater than 150-250 Daltons. The separation of ions with reverse osmosis is aided by charged particles. This means that dissolved ions that carry a charge, such as salts, are more likely to be rejected by the membrane than those that are not charged, such as organics. The larger the charge and the larger the particle, the more likely it will be rejected.

Reverse Osmosis, when properly configured with sediment, carbon and/or carbon block technology, produces pure water that is clearly the body's choice for optimal health. It is the best tasting because it is oxygen-rich.

A Reverse Osmosis System removes virtually all of the following: bad taste, odor, turbidity, organic compounds, herbicides, insecticides, pesticides, chlorine and THM's, bacteria, virus, cysts, parasites, arsenic, heavy metals, lead, cadmium, aluminum, dissolved solids, sodium, calcium, magnesium, inorganic dead dirt minerals, fluoride, sulfates, nitrates, phosphates, detergents, radioactivity and asbestos.

Ozone

Ozone (O_3) is probably the strongest oxidizing agent available for water treatment. Although it is widely used throughout the world, it has not found much application in the United States. Ozone is obtained by passing a flow of air or oxygen between two electrodes that are subjected to an alternating current in the order of 10,000 to 20,000 volts.



Liquid ozone is very unstable and can readily explode. As a result, it is not shipped and must be manufactured on-site. Ozone is a light blue gas at room temperature. It has a self-policing pungent odor similar to that sometimes noticed during and after heavy electrical storms. In use, ozone breaks down into oxygen and nascent oxygen.



It is the nascent oxygen that produces the high oxidation, disinfections, and even sterilization. Each water has its own ozone demand, in the order of 0.5 ppm to 5.0 ppm. Contact time, temperature, and pH of the water are factors in determining Ozone demand. Ozone acts as a complete disinfectant. It is an excellent aid to the flocculation and coagulation process, and will remove practically all color, taste, odor, iron, and manganese. It does not form chloramines or THMs, and while it may destroy some THMs, it may produce other byproducts when followed by chlorination. Ozone is not practical for complete removal of chlorine or chloramines, or of THM and other inorganics. Further, because of the possibility of formation of other carcinogens (such as aldehydes or phthalates) it falls into the same category as other disinfectants, because it can produce DBPs.



Ozone Generator.

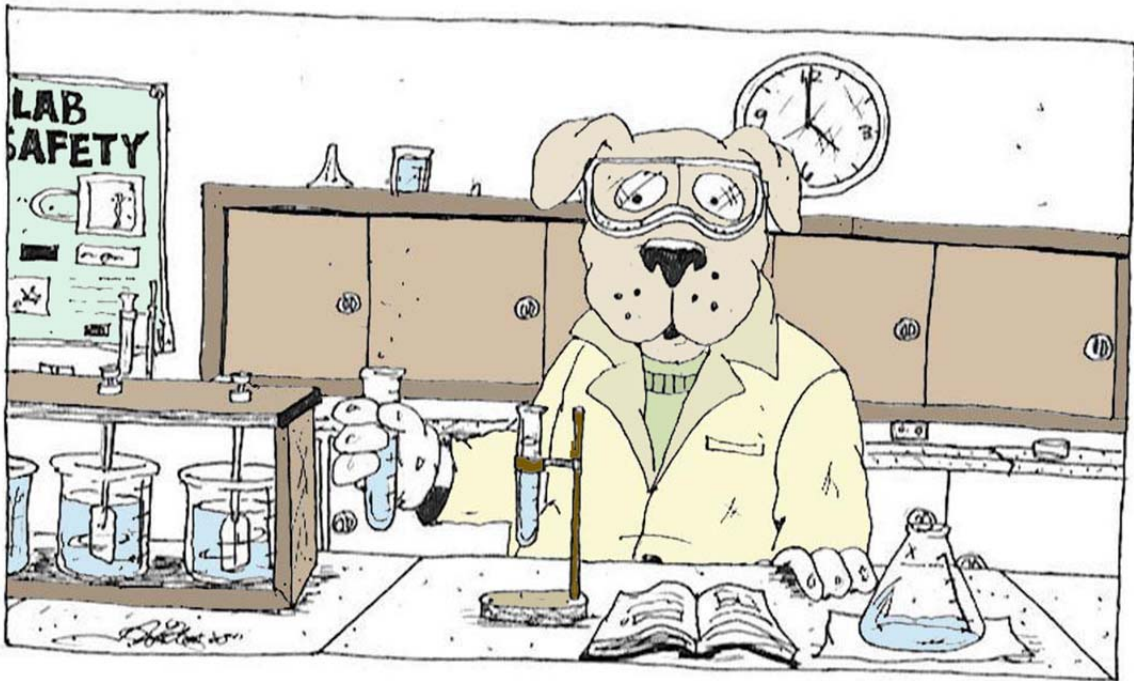

Turbidity

One physical characteristic of water. A measure of the cloudiness of water caused by suspended particles. The cloudy appearance of water caused by the presence of tiny particles. High levels of turbidity may interfere with proper water treatment and monitoring. If high quality raw water is low in turbidity, there will be a reduction in water treatment costs. Turbidity is undesirable because it causes health hazards. An MCL for turbidity established by the EPA because turbidity interferes with disinfection. This characteristic of water changes the most rapidly after a heavy rainfall. The following conditions may cause an inaccurate measure of turbidity; the temperature variation of a sample, a scratched or unclean sample tube in the nephelometer and selecting an incorrect wavelength of a light path.

Ultraviolet Radiation

The enormous temperatures on the sun create ultraviolet (**UV**) rays in great amounts, and this radiation is so powerful that all life on earth would be destroyed if these rays were not scattered by the atmosphere and filtered out by the layers of ozone gas that float some 20 miles above the earth.

This radiation can be artificially produced by sending strong electric currents through various substances. A sun lamp, for example, sends out UV rays that, when properly controlled, result in a suntan. Of course, too much will cause sunburn.



The UV lamp that can be used for the disinfection of water depends upon the low-pressure mercury vapor lamp to produce the ultraviolet energy. A mercury vapor lamp is one in which an electric arc is passed through an inert gas. This, in turn, will vaporize the mercury contained in the lamp resulting in the production of UV rays.



The lamp itself does not come into direct contact with the water. The lamp is placed inside a quartz tube, and the water is in contact with the outside of the quartz tube. Quartz is used in this case since practically none of the UV rays are absorbed by the quartz, allowing all of the rays to reach the water. Ordinary glass cannot be used since it will absorb the UV rays, leaving little for disinfection. The water flows around the quartz tube. The UV sterilizer will consist of a various number of lamps and tubes, depending upon the amount of water to be treated. As water enters the sterilizer, it is given a tangential flow pattern so that the water spins over and around the quartz sleeves. In this way, the microorganisms spend maximum time in contact with the outside of the quartz tube and the source of the UV rays. The basic design flow of water of certain UV units is in the order of 2.0 gpm for each inch of the lamp. Further, the units are designed, so the contact or retention time of the water in the unit is not less than 15 seconds.

Most manufacturers claim UV lamps have a life of about 7,500 hours, which is about 1 year's time. The lamp must be replaced when it loses about 40% to 50% of its UV output; in any installation this is determined by means of a photoelectric cell and a meter that shows the output of the lamp. Each lamp is outfitted with its own photoelectric cell, and an alarm that will be activated when the penetration drops to a preset level.

Ultraviolet radiation is an excellent disinfectant that is highly effective against viruses, molds, and yeasts; and it is safe to use. It adds no chemicals to the water, it leaves no residual, and it does not form THMs. It is used to remove traces of ozone and chloramines from the finished water. Alone, UV radiation will not remove precursors, but in combination with ozone, it is said to be effective in the removal of THM precursors and THMs.

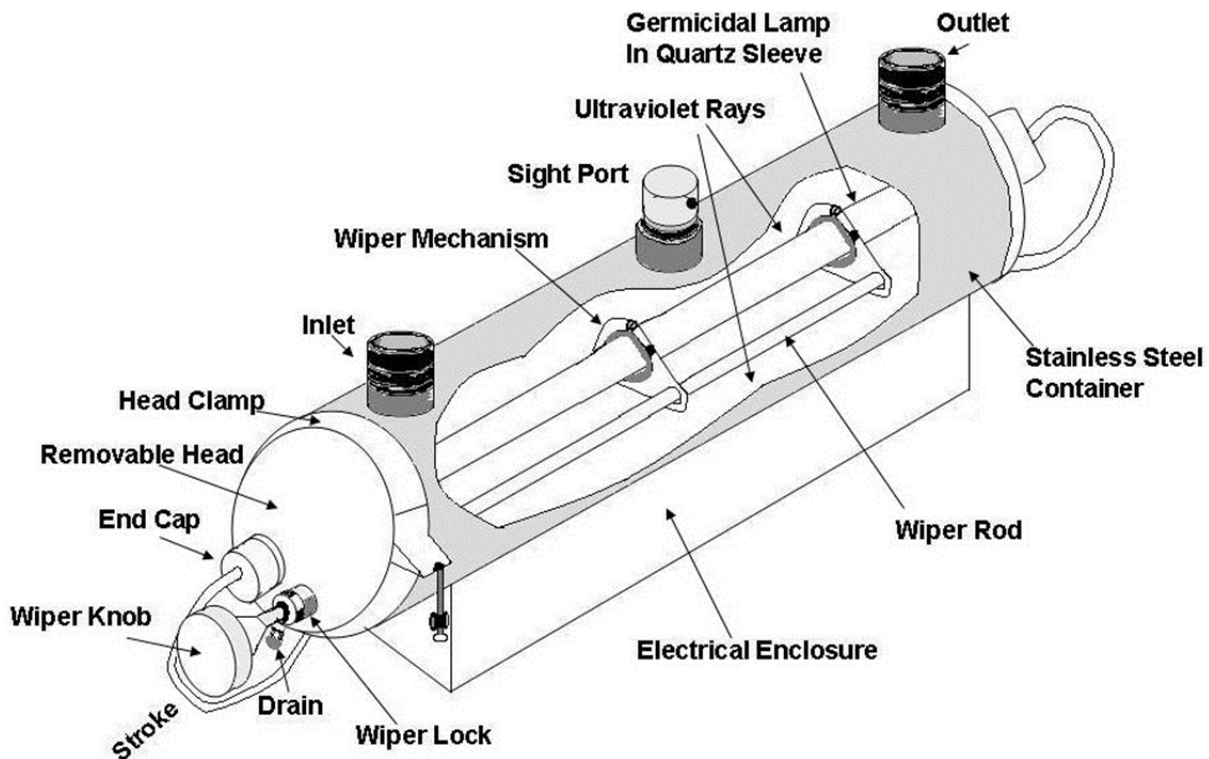

The germicidal effect of UV is thought to be associated with its absorption by various organic components essential to the cell's function. For effective use of ultraviolet, the water to be disinfected must be clean and free of any suspended solids. The water must also be colorless and free of any colloids, iron, manganese, taste, and odor. These are conditions that must be met. Also, although water may appear to be clear, such substances as excesses of chlorides, bicarbonates, and sulfates affect absorption of the ultraviolet rays. These parameters will probably require at least filtration of one type or another. The UV manufacturer will, of course, stipulate which pretreatment may be necessary.

Removal of Disinfection By-Products

<i>Disinfectant</i>	<i>Disinfectant By-product</i>	<i>Disinfectant By-product Removal</i>
Chlorine (HOCl)	Trihalomethane (THM) Chloramine Chlorophenol	Granular Activated Carbon (GAC), resins, controlled coagulation, aeration. GAC-UV GAC
Chloramine (NH _x Cl _y)	Probably no THM Others?	GAC UV?
Chlorine dioxide (ClO ₂)	Chlorites Chlorates	Use of Fe ²⁺ in coagulation, RO, ion- exchange
Permanganate (KMnO ₄)	No THMs	
Ozone (O ₃)	Aldehydes, Carboxylics, Phthalates	GAC
Ultraviolet (UV)	None known	GAC

The table indicates that most of the disinfectants will leave a by-product that is or would possibly be inimical to health. This may aid with a decision as to whether or not precursors should be removed before these disinfectants are added to water.

If it is decided that removal of precursors is needed, research to date indicates that this removal can be attained through the application of controlled chlorination plus coagulation and filtration, aeration, reverse osmosis, nanofiltration, GAC or combinations of other processes.



Modern Water Treatment Disinfectants

Many water suppliers add a disinfectant to drinking water to kill germs such as Giardia and e coli. Especially after heavy rainstorms, your water system may add more disinfectant to guarantee that these germs are killed.

Chlorine. Some people who use drinking water containing chlorine well in excess of EPA standards could experience irritating effects to their eyes and nose. Some people who drink water containing chlorine well in excess of EPA standards could experience stomach discomfort.

Chloramine. Some people who use drinking water containing chloramines well in excess of EPA standards could experience irritating effects to their eyes and nose. Some people who drink water containing chloramines well in excess of EPA standards could experience stomach discomfort or anemia.

Chlorine Dioxide. Some infants and young children who drink water containing chlorine dioxide in excess of EPA standards could experience nervous system effects. Similar effects may occur in fetuses of pregnant women who drink water containing chlorine dioxide in excess of EPA standards. Some people may experience anemia.

Disinfectant alternatives will include Ozone and Ultraviolet light. You will see an increase of these technologies in the near future.

Disinfection Byproducts (DBPS)

Disinfection byproducts form when disinfectants added to drinking water to kill germs react with naturally-occurring organic matter in water.

Total Trihalomethanes. Some people who drink water containing trihalomethanes in excess of EPA standards over many years may experience problems with their liver, kidneys, or central nervous systems, and may have an increased risk of getting cancer.

Haloacetic Acids. Some people who drink water containing haloacetic acids in excess of EPA standards over many years may have an increased risk of getting cancer.

Bromate. Some people who drink water containing bromate in excess of EPA standards over many years may have an increased risk of getting cancer.

Chlorite. Some infants and young children who drink water containing chlorite in excess of EPA standards could experience nervous system effects. Similar effects may occur in fetuses of pregnant women who drink water containing chlorite in excess of EPA standards. Some people may experience anemia.



Corrosion Control

Corrosion is the deterioration of a substance by chemical action. Lead, cadmium, zinc, copper and iron might be found in water when metals in water distribution systems corrode. Drinking water contaminated with certain metals (such as lead and cadmium) can harm human health.

Corrosion also reduces the useful life of water distribution systems and can promote the growth of microorganisms, resulting in disagreeable tastes, odors, slimes and further corrosion. Because it is widespread and highly toxic, lead is the corrosion product of greatest concern. The EPA has banned the use of lead solders, fluxes and pipes in the installation or repair of any public water system. In the past, solder used in plumbing has been 50% tin and 50% lead. Using lead-free solders, such as silver-tin and antimony-tin is a key factor in lead corrosion control.

The highest level of lead in consumers' tap water will be found in water that has been standing in the pipes after periods of nonuse (overnight or longer). This is because standing water tends to leach lead or copper out of the metals in the distribution system more readily than does moving water. Therefore, the simplest short-term or immediate measure that can be taken to reduce exposure to lead in drinking water is to let the water run for two to three minutes before each use. Also, drinking water should not be taken from the hot water tap, as hot water tends to leach lead more readily than cold.

Long-term measures for addressing lead and other corrosion by-products include pH and alkalinity adjustment; corrosion inhibitors; coatings and linings; and Cathodic protection, all discussed below.

Cathodic Protection

Cathodic protection protects steel from corrosion which is the natural electrochemical process that results in the deterioration of a material because of its reaction with its environment.

Metallic structures, components, and equipment exposed to aqueous environments, soil, or seawater can be subject to corrosive attack and accelerated deterioration. Therefore, it is often necessary to utilize either impressed current or sacrificial anode Cathodic protection (CP) in combination with coatings as a means of suppressing the natural degradation phenomenon to provide a long and useful service life. However, if proper considerations are not given, problems can arise which can produce unexpected, premature failure.

There are two types of Cathodic protection:

- Ø Sacrificial Anodes (Galvanic Systems)
- Û Impressed (Induced) Current Systems

How Does Cathodic Protection Work?

Sacrificial anodes are pieces of metal more electrically active than the steel piping system.

Because these anodes are more active, the corrosive current will exit from them rather than the piping system. Thus, the system is protected while the attached anode is "**sacrificed**."

Sacrificial anodes can be attached to the existing piping system or coated steel for a pre-engineered cathodic protection system. An asphalt coating is not considered a suitable dielectric coating. Depleted anodes must be replaced for continued Cathodic protection of the system.

Impressed or Induced Current Systems

An impressed current cathodic protection system consists of anodes, cathodes, a rectifier and the soil. The rectifier converts the alternating current to direct current. The direct current is then sent through an insulated copper wire to anodes that are buried in the soil near the piping system. Typical anode materials are ceramic, high silicon cast iron, or graphite.

Ceramic anodes are not consumed, whereas high silicon cast iron and graphite anodes partially dissolve each year and must be replaced over time. The direct current then flows from the anode through the soil to the piping system, which acts as the cathode, and back to the rectifier through another insulated copper wire.

As a result of the electrochemical properties of the impressed current cathodic protection system, corrosion takes place only at the anodes and not at the piping system. Depleted anodes must be replaced for continued cathodic protection of the piping system.

Sacrificial Anode System

In this system, a metal or alloy reacting more vigorously than the corroding specimen acts as an anode and the corroding structure as a whole is rendered Cathodic. These anodes are made of materials such as magnesium, aluminum or zinc, which are anodic with respect to the protected structure. The sacrificial anodes are connected directly to the structure.

Advantages

1. Needs no external power source.
2. Does not involve maintenance work
3. If carefully designed, it can render protection for anticipated period.
4. Installation is simple.
5. Does not involve expensive accessories like rectifier unit, etc.,
6. Economical for small structures

Disadvantages

1. The driving voltage is small and therefore the anodes have to be fitted close to the structure or on the structure, thereby increasing the weight or load on the structure.
2. The anodes have to be distributed all over the structure (as throwing power is lower) and therefore have design limitations in certain applications.
3. Once designed and installed, protection current cannot be altered or increased as may be needed in case of cathode area extension (unprotected) or foreign structure interference (physical contact).

Impressed Current System

The impressed current anode system, on the other hand, has several advantages over the sacrificial anode systems. In this system the protection current is "**Forced**" through the environment to the structure (cathode) by means of an external D.C. source. Obviously we need some material to function as anodes. It can be high silicon chromium cast iron anodes, graphite anodes, or lead-silver alloy anodes.

Advantages

1. Since the driving voltage is large, this system offers freedom of installation design and location
2. Fewer anodes can protect a large structure
3. Variations in protection current requirements can be adjusted to some extent (to be incorporated at design stage)

Disadvantages

1. Shut down of D.C. supply for a long time allows structure to corrode again.
2. Reversal of anode cathode connection at D.C. source will be harmful as structure will dissolve anodic
3. Needs trained staff for maintenance of units and for monitoring
4. Initial investments are higher and can pay off only in long run and economic only for large structures
5. Power cost must be incorporated in all economic consideration.
6. Possibility of overprotection should be avoided as it will affect the life of the paint.
7. Any foreign structure coming within this field will cause an interference problem.



Raw Water Intake

Alkalinity and pH Adjustment

Adjusting pH and alkalinity is the most common corrosion control method because it is simple and inexpensive. pH is a measure of the concentration of hydrogen ions present in water; alkalinity is a measure of water's ability to neutralize acids.

Generally, water pH less than 6.5 is associated with uniform corrosion, while pH between 6.5 and 8.0 can be associated with pitting corrosion. Some studies have suggested that systems using only pH to control corrosion should maintain a pH of at least 9.0 to reduce the availability of hydrogen ions as electron receptors. However, pH is not the only factor in the corrosion equation; carbonate and alkalinity levels affect corrosion as well.

Generally, an increase in pH and alkalinity can decrease corrosion rates and help form a protective layer of scale on corrodible pipe material. Chemicals commonly used for pH and alkalinity adjustment are hydrated lime (CaOH_2 or calcium hydroxide), caustic soda (NaOH or sodium hydroxide), soda ash (Na_2CO_3 or sodium carbonate), and sodium bicarbonate (NaHCO_3 , essentially baking soda).

Care must be taken, however, to maintain pH at a level that will control corrosion but not conflict with optimum pH levels for disinfection and control of disinfection by-products.

Corrosion Inhibitors

Inhibitors reduce corrosion by forming protective coatings on pipes. The most common corrosion inhibitors are inorganic phosphates, sodium silicates and mixtures of phosphates and silicates. These chemicals have proven successful in reducing corrosion in many water systems.

The phosphates used as corrosion inhibitors include polyphosphates, orthophosphates, glassy phosphates and bimetallic phosphates. In some cases, zinc is added in conjunction with orthophosphates or polyphosphates.

Glassy phosphates, such as sodium hexametaphosphate, effectively reduce iron corrosion at dosages of 20 to 40 mg/l. Glassy phosphate has an appearance of broken glass and can cut the operator. Sodium silicates have been used for over 50 years to inhibit corrosion. The effectiveness depends on the water pH and carbonate concentration.

Sodium silicates are particularly effective for systems with high water velocities, low hardness, low alkalinity and a pH of less than 8.4. Typical coating maintenance doses range from 2 to 12 mg/l. They offer advantages in hot water systems because of their chemical stability. For this reason, they are often used in the boilers of steam heating systems.





Common water sample bottles for distribution systems.

Radiochems, VOCs, (Volatile Organic Compounds), TTHMs, Total Trihalomethanes), Nitrate, Nitrite.

Most of these sample bottles will come with the preservative already inside the bottle.

Some bottles will come with a separate preservative (acid) for the field preservation.

Slowly add the acid or other preservative to the water sample; not water to the acid or preservative.

Surface Water

Some of the water will be immediately impounded in lakes and reservoirs, and some will collect as runoff to form streams and rivers that will then flow into the ocean. Water is known as the universal solvent because most substances that come in contact with it will dissolve. What's the difference between lakes and reservoirs? Reservoirs are lakes with man-made dams. Surface water is usually contaminated and unsafe to drink. Depending on the region, some lakes and rivers receive discharge from sewer facilities or defective septic tanks. Runoff could produce mud, leaves, decayed vegetation, and human and animal refuse. The discharge from industry could increase volatile organic compounds. Some lakes and reservoirs may experience seasonal turnover. Changes in the dissolved oxygen, algae, temperature, suspended solids, turbidity, and carbon dioxide will change because of biological activities.

Quality of Water

If you classified water by its characteristics and could see how water changes as it passes on the surface and below the ground it would be in these four categories:

Physical characteristics such as taste, odor, temperature, and turbidity; this is how the consumer judges how well the provider is treating the water.

Chemical characteristics are the elements found that are considered alkali, metals, and non-metals such as fluoride, sulfides or acids. The consumer relates it to scaling of faucets or staining.

Biological characteristics are the presence of living or dead organisms. This will also interact with the chemical composition of the water. The consumer will become sick or complain about hydrogen sulfide odors--the rotten egg smell.

Radiological characteristics are the result of water coming in contact with radioactive materials. This could be associated with atomic energy.

Managing Water Quality at the Source

Depending on the region, source water may have several restrictions of use as part of a Water Shed Management Plan. In some areas, it may be restricted from recreational use, discharge or runoff from agriculture, or industrial and wastewater discharge. Another aspect of quality control is aquatic plants. The ecological balance in lakes and reservoirs plays a natural part in purifying and sustaining the life of the lake. For example, algae and rooted aquatic plants are essential in the food chain of fish and birds. Algae growth is the result of photosynthesis. Algae growth is supplied by the energy of the sun. As algae absorbs this energy, it converts carbon dioxide to oxygen.



This creates **aerobic** conditions that supply fish with oxygen. Without sun light, the algae would consume oxygen and release carbon dioxide. The lack of dissolved oxygen in water is known as **anaerobic** conditions. Certain vegetation removes the excess nutrients that would promote the growth of algae. Too much algae will imbalance the lake and kill fish.

Most treatment plant upsets such as taste and odor, color, and filter clogging is due to algae. The type of algae determines the problem it will cause, for instance slime, corrosion, color, and toxicity. Algae have been controlled by using chemicals such as copper sulfate. Depending on federal regulations and the amount of copper found natural in water, operators have used potassium permanganate, powdered activated carbon and chlorine. The pH and alkalinity of the water will determine how these chemicals will react. Most systems no longer use Chlorine because it reacts with the organics in the water to form Trihalomethanes.



Examples of different types of chemical storage tanks found in water treatment facilities.



Review Statements

Surface Water

As with Surface water, it is important to remember that activities many miles away from you may affect the quality of ground water. Your annual drinking report or CCR will tell you where your water supplier gets your water. Your water will normally contain chlorine and varying amounts of dissolved minerals including calcium, magnesium, sodium, chlorides, sulfates and bicarbonates, depending on its source. It is also not uncommon to find traces of iron, manganese, copper, aluminum, nitrates, insecticides and herbicides. Although the maximum amounts of all these substances as mentioned above, are strictly limited by the regulations. These are usually referred to as contaminants

Surface water is usually contaminated and unsafe to drink. Depending on the region, some lakes and rivers receive discharge from sewer facilities or defective septic tanks.

Runoff could produce mud, leaves, decayed vegetation, and human and animal refuse. The discharge from industry could increase volatile organic compounds.

Some lakes and reservoirs may experience seasonal turnover.

Changes in the dissolved oxygen, algae, temperature, suspended solids, turbidity, and carbon dioxide will change because of biological activities.

Physical characteristics such as taste, odor, temperature, and turbidity; this is how the consumer judges how well the provider is treating the water. Physical characteristics are the elements found that are considered alkali, metals, and non-metals such as fluoride, sulfides or acids. The consumer relates it to scaling of faucets or staining.

Biological characteristics are the presence of living or dead organisms. Biological characteristics will also interact with the chemical composition of the water. The consumer will become sick or complain about hydrogen sulfide odors, the rotten egg smell.

Radiological characteristics are the result of water coming in contact with radioactive materials. This could be associated with atomic energy.

Most of these substances are of natural origin and are picked up as water passes around the water cycle. Some are present due to the treatment processes which are used make the water suitable for drinking and cooking. The water will also contain a relatively low level of bacteria, which are not generally a risk to health.

Insecticides and herbicides (sometimes referred to as pesticides) are widely used in agriculture, industry, leisure facilities and gardens to control weeds and insect pests and may enter the water cycle in many ways.

Aluminum salts are added during water treatment to remove color and suspended solids.

Lead does not usually occur naturally in water supplies but is derived from lead distribution and domestic pipework and fittings.

Water suppliers have removed most of the original lead piping from the mains distribution system, many older properties still have lead service pipes and internal lead pipework.

The pipework (including the service pipe) within the boundary of the property is the responsibility of the owner of the property, not the water supplier.

Hardness

There are two types of hardness: temporary and permanent. Temporary hardness comes out of the water when it's heated and is deposited as scale and fur on kettles, coffee makers and taps and appears as a scum or film on tea and coffee. Permanent hardness is unaffected by heating.

Cysts

Cysts are associated with the reproductive stages of parasitic micro-organisms (protozoans) which can cause acute diarrhea type illnesses; they come from farm animals, wild animals and people. Cysts are very resistant to normal disinfection processes but can be removed by advanced filtration processes installed in water treatment works. Cysts are rarely present in the public water supply.

Particles and rust come from the gradual breakdown of the lining of concrete or iron mains water pipes or from sediment which has accumulated over the years and is disturbed in some way.



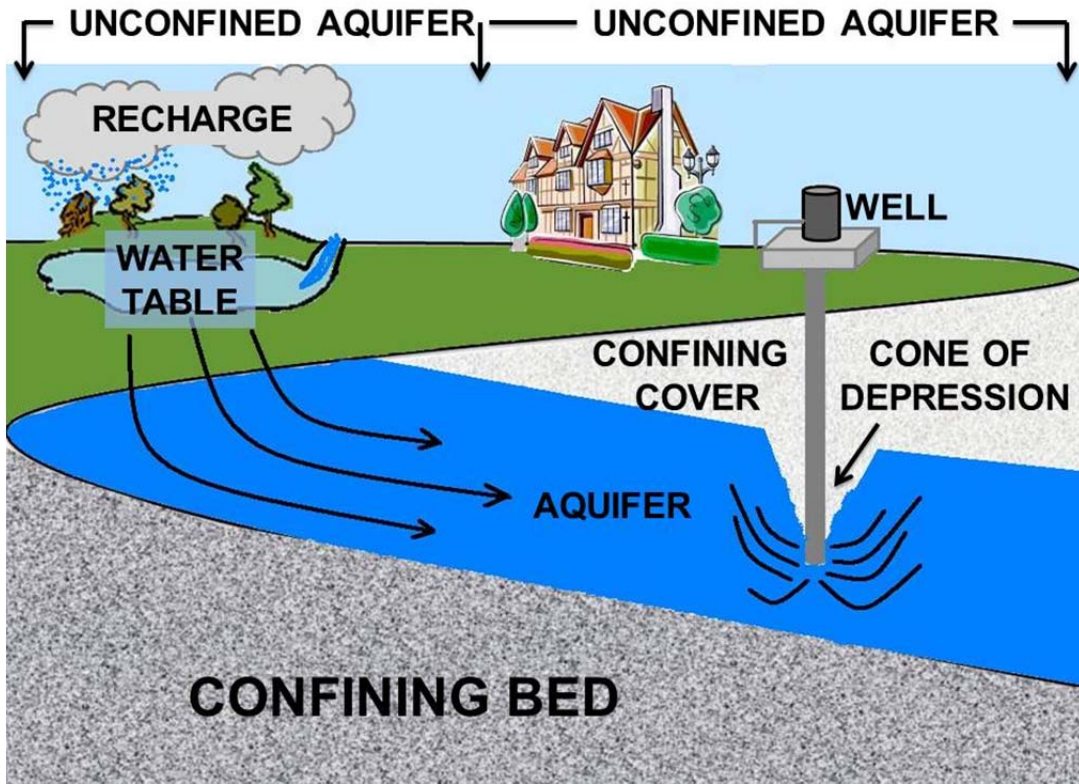

Different types of Aquifers.

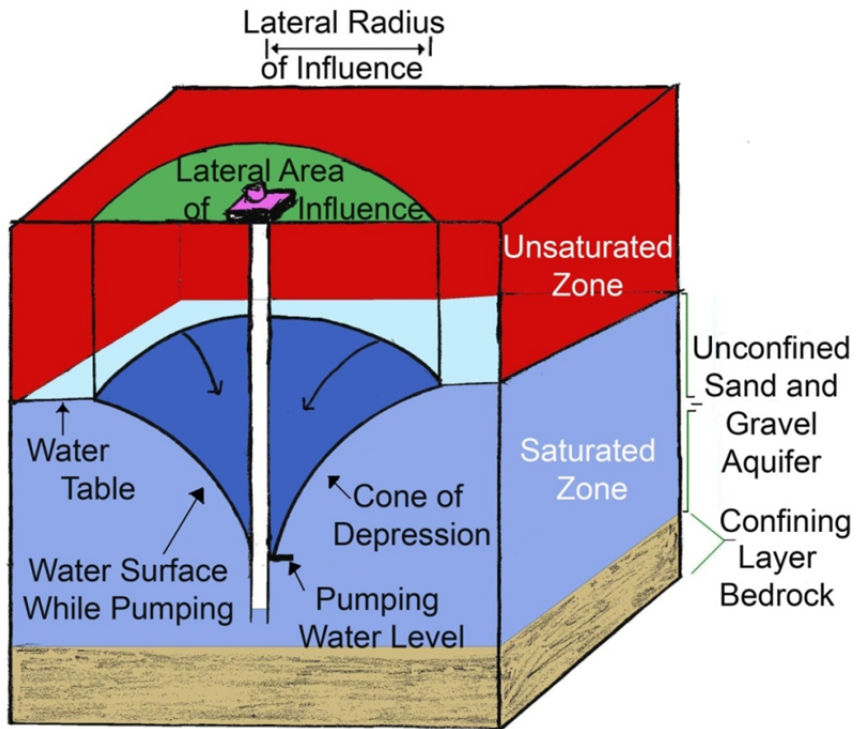

Water Production Section Chapter 4

Groundwater and Wells

A well can be easily contaminated if it is not properly constructed or if toxic materials are released into the well. Toxic material spilled or dumped near a well can leach into the aquifer and contaminate the groundwater drawn from that well. Contaminated wells used for drinking water are especially dangerous. Wells can be tested to see what chemicals may be in the well and if they are present in dangerous quantities.

Groundwater is withdrawn from wells to provide water for everything from drinking water for the home and business to water for irrigating crops. When water is pumped from the ground, the dynamics of groundwater flow change in response to this withdrawal. Groundwater flows slowly through water-bearing formations (aquifers) at different rates. In some places, where groundwater has dissolved limestone to form caverns and large openings, its rate of flow can be relatively fast, but this is exceptional.



Groundwater production well with a mineral oil sealed vertical turbine pump. Sometimes, this mineral oil will get into the distribution system.

Groundwater Resource

Many terms are used to describe the nature and extent of the groundwater resource. The level below which all the spaces are filled with water is called the **water table**. Above the water table lies the **unsaturated zone**. Here the spaces in the rock and soil contain both air and water. Water in this zone is called **soil moisture**. The entire region below the water table is called the **saturated zone** and water in this saturated zone is called **groundwater**.

Fractured aquifers are rocks in which the groundwater moves through cracks, joints or fractures in otherwise solid rock. Examples of fractured aquifers include granite and basalt. Limestones are often fractured aquifers, but here the cracks and fractures may be enlarged by solution, forming large channels or even caverns. Limestone terrain where solution has been very active is termed **karst**. Porous media such as sandstone may become so highly cemented or recrystallized that all of the original space is filled. In this case, the rock is no longer a porous medium. However, if it contains cracks it can still act as a fractured aquifer. Most of the aquifers of importance to us are unconsolidated porous media such as sand and gravel. Some very porous materials are not permeable. Clay, for instance, has many spaces between its grains, but the spaces are not large enough to permit free movement of water.

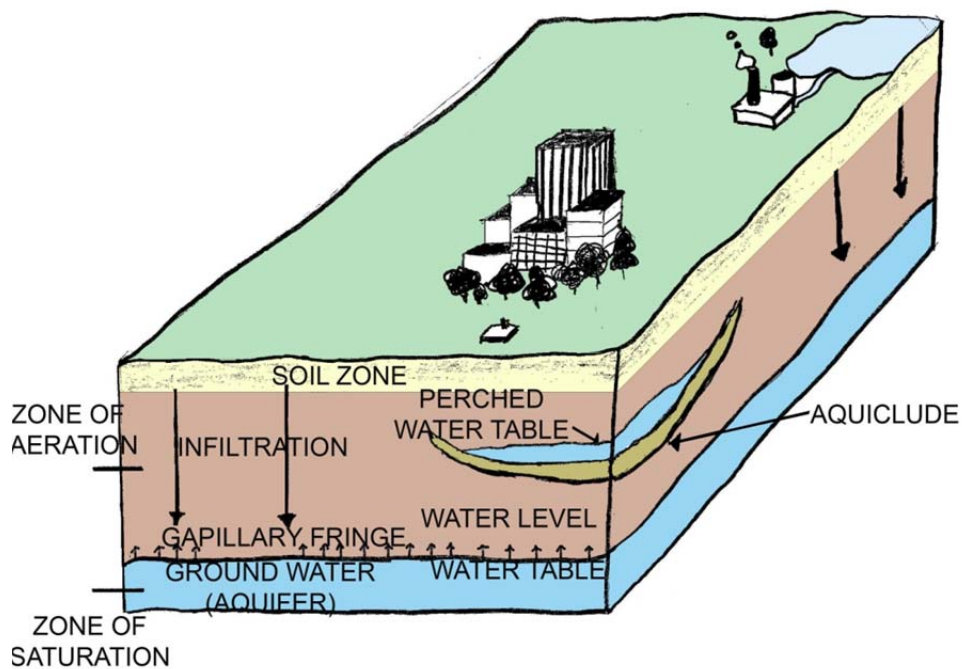

Groundwater usually flows downhill with the slope of the water table. Like surface water, groundwater flows toward, and eventually drains into, streams, rivers, lakes and the oceans. Groundwater flow in the aquifers underlying surface drainage basins, however, does not always mirror the flow of water on the surface. Therefore, groundwater may move in different directions below the ground than the water flowing on the surface.

Unconfined aquifers are those that are bounded by the water table. Some aquifers, however, lie beneath layers of impermeable materials. These are called **confined aquifers**, or sometimes **artesian aquifers**. A well in such an aquifer is called an **artesian well**. The water in these wells rises higher than the top of the aquifer because of confining pressure. If the water level rises above the ground surface, a **flowing artesian well** occurs. The **piezometric surface** is the level to which the water in an artesian aquifer will rise.

Water Sources

Before we discuss the types of treatment it is easier to first understand how the source of water arrives.

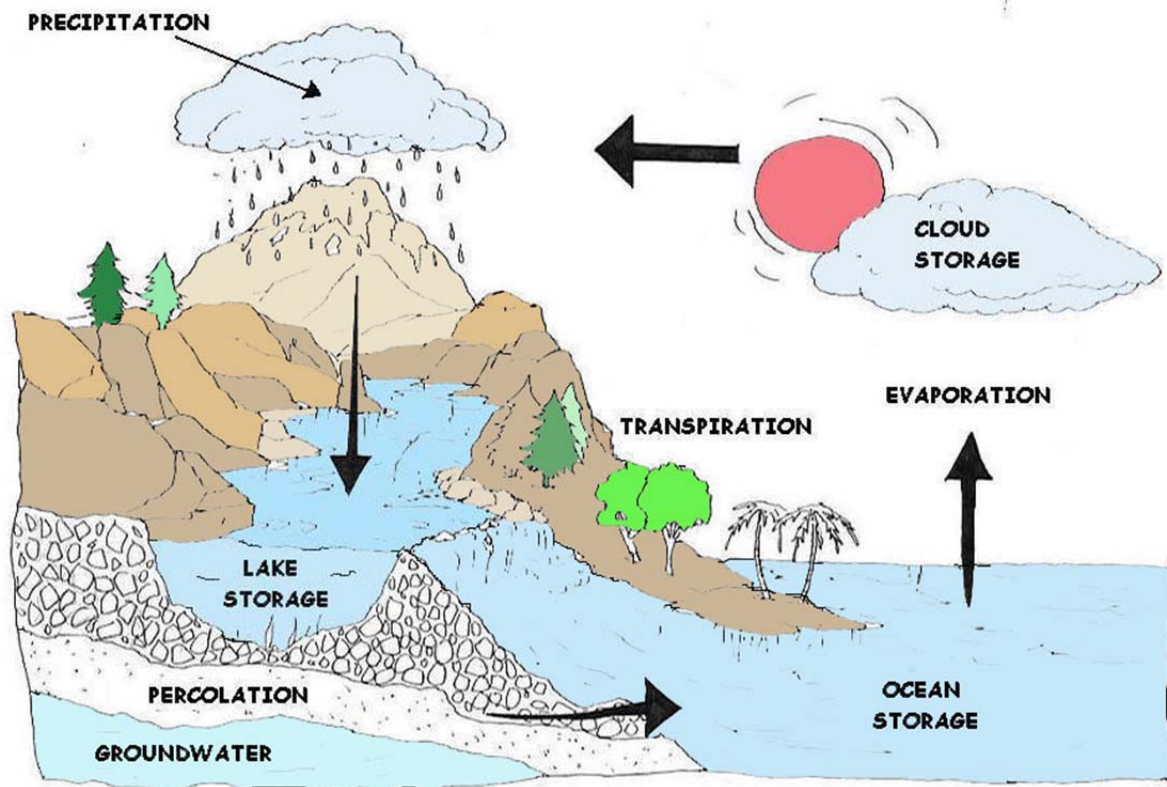

Water Cycle Terms - Good information for your Assignment.

- **Precipitation:** The process by which atmospheric moisture falls onto the land or water surface as rain, snow, hail, or other forms of moisture.
- **Infiltration:** The gradual flow or movement of water into and through the pores of the soil.
- **Evaporation:** The process by which the water or other liquids become a gas.
- **Condensation:** The collection of the evaporated water in the atmosphere.
- **Runoff:** Water that drains from a saturated or impermeable surface into stream channels or other surface water areas. Most lakes and rivers are formed this way.
- **Transpiration:** Moisture that will come from plants as a byproduct of photosynthesis.

Once the precipitation begins, water is no longer in its purest form. Water will be collected as surface supplies or circulate to form in the ground. As it becomes rain or snow it may be polluted with organisms, organic compounds, and inorganic compounds. Because of this, we must treat the water for human consumption.

Source Water Quality

Groundwater

Groundwater contributes most of all of the water that is derived from wells or springs. It occurs in the natural open spaces (i.e., fractures or pore spaces between grains) in sediments and rocks below the surface. Groundwater is distributed fairly evenly throughout the crust of the earth, but it is not readily accessible or extractable everywhere. More than 90 percent of the world's total supply of drinkable water is groundwater.

Groundwater originates as precipitation that sinks into the ground. Some of this water percolates down to the water table (shallowest surface of the groundwater) and recharges the aquifer. For shallow wells (i.e., less than 50-75 feet) the recharge area is often the immediate vicinity around the well or **"wellhead."** Some wells are recharged in areas that may be a great distance from the well itself. If the downward percolating precipitation encounters any source of contamination, at the surface or below it, the water may dissolve some of that contaminant and carry it to the aquifer. Groundwater moves from areas where the water table is high to where the water table is low. Consequently, a contaminant may enter the aquifer some distance upgradient from you and still move towards your well. When a well is pumping, it lowers the water table in the immediate vicinity of the well, increasing the tendency for water to move towards the well. Contaminants can be lumped into three categories: microorganisms (bacteria, viruses, Giardia, etc.), inorganic chemicals (nitrate, arsenic, metals, etc.) and organic chemicals (solvents, fuels, pesticides, etc.).

Although it is common practice to associate contamination with highly visible features such as landfills, gas stations, industry or agriculture, potential contaminants are widespread and often come from common everyday activities as well, such as septic systems, lawn and garden chemicals, pesticides applied to highway right-of-ways, stormwater runoff, auto repair shops, beauty shops, dry cleaners, medical institutions, photo processing labs, etc. Importantly, it takes only a very small amount of some chemicals in drinking water to raise health concerns. For example, one gallon of pure trichloroethylene, a common solvent, will contaminate approximately 292 million gallons of water.

Wellhead Protection

Wellhead protection refers to programs designed to maintain the quality of groundwater used as public drinking water sources by managing the land uses around the wellfield. The theory is that management of land use around the well, and over water moving (underground) toward the well, will help to minimize damage to subsurface water supplies by spills or improper use of chemicals. The concept usually includes several stages.

Wellhead Protection Sequence

- A) Build a community-wide planning team.
- B) Delineate geologically the protection zone.
- C) Perform a contaminant use inventory.
- D) Create a management plan for the protection zone.
- E) Plan for the future.

Water Rights

Appropriative: Acquired water rights for exclusive use.

Prescriptive: Rights based upon legal prescription or long use or custom.

Riparian: Water rights because property is adjacent to a river or surface water.

Contaminated Wells

Contaminated wells used for drinking water are especially dangerous. Wells can be tested to see what chemicals may be in the well and if they are present in dangerous quantities.

Groundwater is withdrawn from wells to provide water for everything from drinking water for the home and business to water to irrigate crops to industrial processing water. When water is pumped from the ground, the dynamics of groundwater flow change in response to this withdrawal. Groundwater flows slowly through water-bearing formations (aquifers) at different rates. In some places, where groundwater has dissolved limestone to form caverns and large openings, its rate of flow can be relatively fast but this is exceptional.



Well with a mineral oil sealed vertical turbine pump.

Aquifer

Many terms are used to describe the nature and extent of the groundwater resource. The level below which all the spaces are filled with water is called the *water table*. Above the water table lies the *unsaturated zone*. Here the spaces in the rock and soil contain both air and water. Water in this zone is called *soil moisture*. The entire region below the water table is called the *saturated zone* and water in this saturated zone is called *groundwater*.

Fractured aquifers are cracks, joints, or fractures in solid rock, through which groundwater moves. Examples of fractured aquifers include granite and basalt. Limestones are often fractured aquifers, but here the cracks and fractures may be enlarged by solution, forming large channels or even caverns. Limestone terrain where solution has been very active is termed *karst*.

Porous media such as sandstone may become so highly cemented or recrystallized that all of the original space is filled. In this case, the rock is no longer a porous medium. However, if it contains cracks it can still act as a fractured aquifer. Most of the aquifers of importance to us are unconsolidated porous media such as sand and gravel. Some very porous materials are not permeable. Clay, for instance, has many spaces between its grains, but the spaces are not large enough to permit free movement of water.

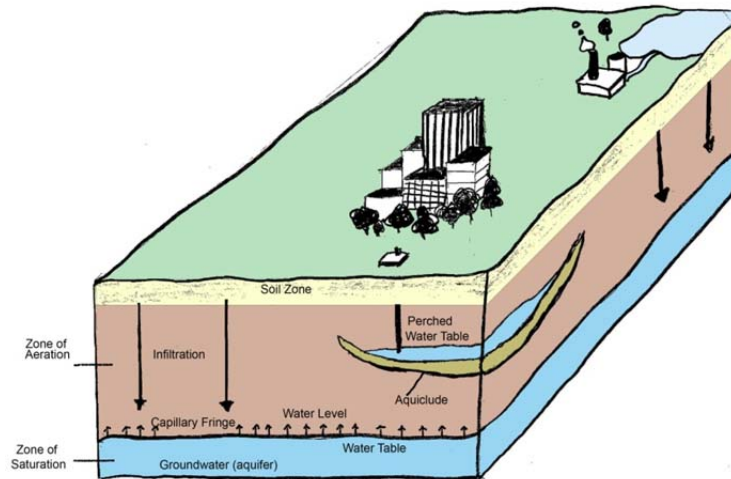

Groundwater usually flows downhill with the slope of the water table. Like surface water, groundwater flows toward, and eventually drains into, streams, rivers, lakes and the oceans.

Groundwater flow in the aquifers underlying springs or surface drainage basins, however, does not always mirror the flow of water on the surface.

Therefore, groundwater may move in different directions below the ground than the water flowing on the surface.



Vertical Turbine Well

Unconfined aquifers are those that are bounded by the water table. Some aquifers, however, lie beneath layers of impermeable materials. These are called *confined aquifers*, or some-times *artesian aquifers*. A well in such an aquifer is called an *artesian well*. The water in these wells rises higher than the top of the aquifer because of confining pressure. If the water level rises above the ground surface a *flowing artesian well* occurs.

The *piezometric surface* is the level to which the water in an artesian aquifer will rise.

Cone of Depression

When pumping begins, water begins to flow towards the well in contrast to the natural direction of groundwater movement. The water level in the well falls below the water table in the surrounding aquifer.

As a result, water begins to move from the aquifer into the well. As pumping continues, the water level in the well continues to increase until the rate of flow into the well equals the rate of withdrawal from pumping. The movement of water from an aquifer into a well results in the formation of a cone of depression. The cone of depression describes a three-dimensional inverted cone surrounding the well that represents the volume of water removed as a result of pumping. Drawdown is the vertical drop in the height between the water level in the well prior to pumping and the water level in the well during pumping.

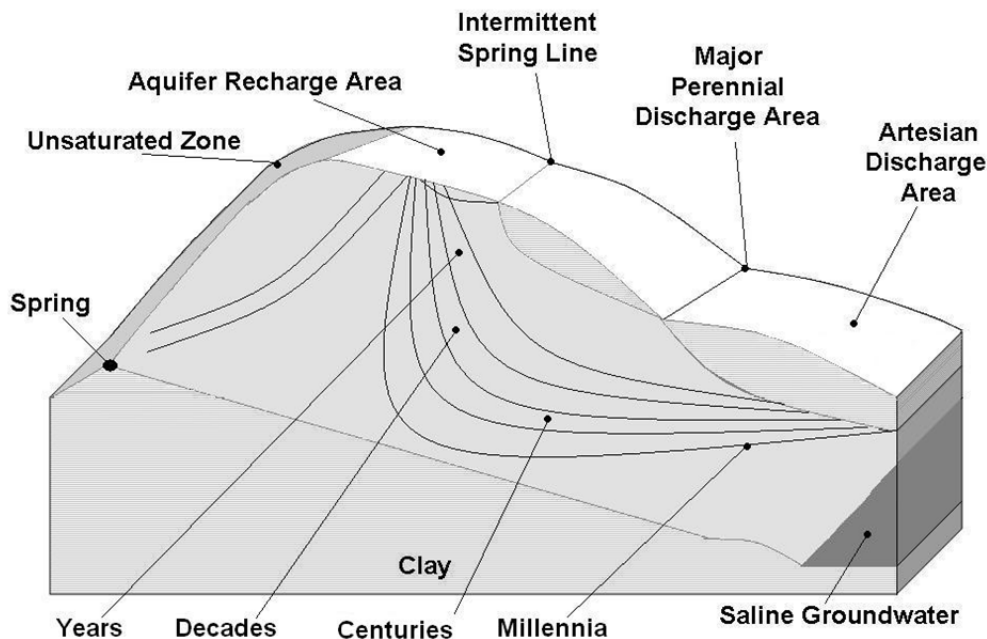

When a well is installed in an unconfined aquifer, water moves from the aquifer into the well through small holes or slits in the well casing or, in some types of wells, through the open bottom of the well. The level of the water in the well is the same as the water level in the aquifer. Groundwater continues to flow through and around the well in one direction in response to gravity.

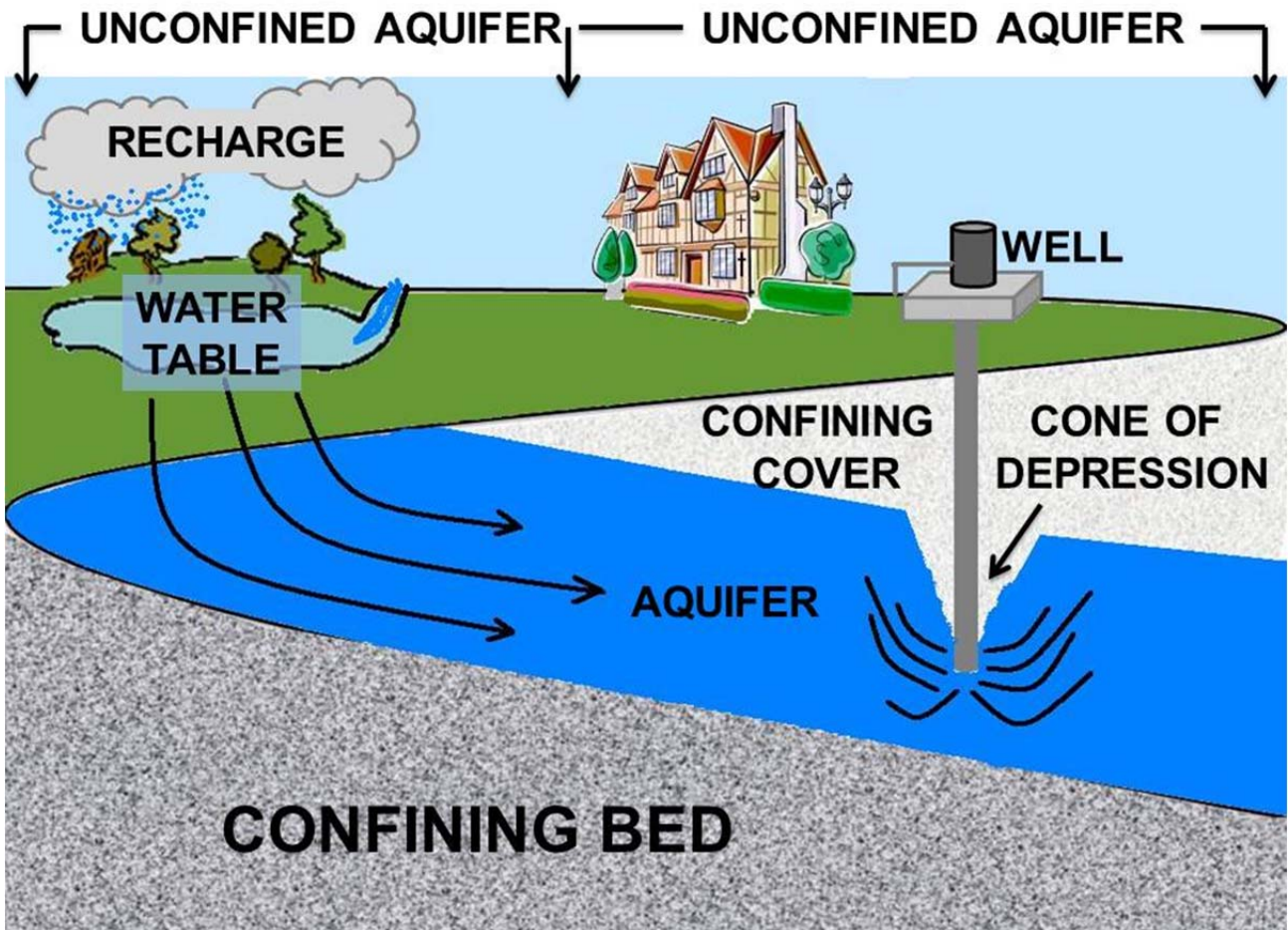

Aquifer Description

Groundwater Section

Half of all Americans and more than 95 percent of rural Americans get their household water supplies from underground sources of water, or ground water. Ground water also is used for about half of the nation's agricultural irrigation and nearly one-third of the industrial water needs. This makes ground water a vitally important national resource.

Over the last 10 years, however, public attention has been drawn to incidents of ground-water contamination. This has led to the development of ground-water protection programs at federal, state, and local levels. Because ground-water supplies and conditions vary from one area to another, the responsibility for protecting a community's ground-water supplies rests substantially with the local community.

If your community relies on ground water to supply any portion of its fresh water needs, you, the citizen, will be directly affected by the success or failure of a ground-water protection program. Equally important, you, the citizen, can directly affect the success or failure of your community's ground-water protection efforts.

This guide is intended to help you take an active and positive role in protecting your community's ground-water supplies. It will introduce you to the natural cycle that supplies the earth with ground water, briefly explain how ground water can become contaminated, examine ways to protect our vulnerable ground-water supplies, and, most important of all, describe the roles you and your community can play in protecting valuable ground-water supplies.



Groundwater Transducer (pH, Temp. chemical detection and D.O.) depth probe. These tools are used to find the depth and pH of well water.

Groundwater Explained

Many people have never heard of ground water. That's not really so surprising since it isn't readily visible -- ground water can be considered one of our "**hidden**" resources.

What Is Groundwater and Where Does It Come From?

Actually ground water occurs as part of what can be called the oldest recycling program - the hydrologic cycle. The hydrologic cycle involves the continual movement of water between the earth and the atmosphere through evaporation and precipitation. As rain and snow fall to the earth, some of the water runs off the surface into lakes, rivers, streams, and the oceans; some evaporates; and some is absorbed by plant roots. The rest of the water soaks through the ground's surface and moves downward through the unsaturated zone, where the open spaces in rocks and soil are filled with a mixture of air and water, until it reaches the water table. The water table is the top of the saturated zone, or the area in which all interconnected spaces in rocks and soil are filled with water. The water in the saturated zone is called ground water. In areas where the water table occurs at the ground's surface, the ground water discharges into marshes, lakes, springs, or streams and evaporates into the atmosphere to form clouds, eventually falling back to earth again as rain or snow - thus beginning the cycle all over again.

Where Is Ground Water Stored?

Ground water is stored under many types of geologic conditions. Areas where ground water exists in sufficient quantities to supply wells or springs are called aquifers, a term that literally means "water bearer." Aquifers store water in the spaces between particles of sand, gravel, soil, and rock as well as cracks, pores, and channels in relatively solid rocks. An aquifer's storage capacity is controlled largely by its porosity, or the relative amount of open space present to hold water. Its ability to transmit water, or permeability, is based in part on the size of these spaces and the extent to which they are connected. Basically, there are two kinds of aquifers: confined and unconfined. If the aquifer is sandwiched between layers of relatively impermeable materials (e.g., clay), it is called a confined aquifer. Confined aquifers are frequently found at greater depths than unconfined aquifers. In contrast, unconfined aquifers are not sandwiched between these layers of relatively impermeable materials, and their upper boundaries are generally closer to the surface of the land.

Does Ground Water Move?

Ground water can move sideways as well as up or down. This movement is in response to gravity, differences in elevation, and differences in pressure. The movement is usually quite slow, frequently as little as a few feet per year, although it can move as much as several feet per day in more permeable zones. Ground water can move even more rapidly in karst aquifers, which are areas in water soluble limestone and similar rocks where fractures or cracks have been widened by the action of the ground water to form sinkholes, tunnels, or even caves.

How Is Ground Water Used?

According to the U.S. Geological Survey, ground-water use increased from about 35 billion gallons a day in 1950 to about 87 billion gallons a day in 1980. Approximately one-half of all fresh water used in the nation comes from ground water. Whether it arrives via a public water supply system or directly from a private well, ground water ultimately provides approximately 35 percent of the drinking water supply for urban areas and 95 percent of the supply for rural areas, quenching the thirst and meeting other household needs of more than 117 million people in this nation.

Overall, more than one-third of the water used for agricultural purposes is drawn from ground water; Arkansas, Nebraska, Colorado, and Kansas use more than 90 percent of their ground-water withdrawals for agricultural activities. In addition, approximately 30 percent of all ground water is used for industrial purposes. Groundwater use varies among the states, with some states, such as Hawaii, Mississippi, Florida, Idaho, and New Mexico, relying on ground water to supply considerably more than three-fourths of their household water needs and other states, such as Colorado and Rhode Island, supplying less than one-quarter of their water needs with ground water.

Ground-Water Quality

Until the 1970s, ground water was believed to be naturally protected from contamination. The layers of soil and particles of sand, gravel, crushed rocks, and larger rocks were thought to act as filters, trapping contaminants before they could reach the ground water. Since then, however, every state in the nation has reported cases of contaminated ground water, with some instances receiving widespread publicity. We now know that some contaminants can pass through all of these filtering layers into the saturated zone to contaminate ground water.

Between 1971 and 1985, 245 ground-water related disease outbreaks, with 52,181 associated illnesses, were reported. Most of these diseases were short-term digestive disorders. About 10 percent of all ground-water public water supply systems are in violation of drinking water standards for biological contamination. In addition, approximately 74 pesticides, a number of which are known carcinogens, have been detected in the ground water of 38 states. Although various estimates have been made about the extent of ground-water contamination, these estimates are difficult to verify given the nature of the resource and the difficulty of monitoring its quality.

How Does Ground Water Become Contaminated?

Ground-water contamination can originate on the surface of the ground, in the ground above the water table, or in the ground below the water table. Table 1 shows the types of activities that can cause ground-water contamination at each level. Where a contaminant originates is a factor that can affect its actual impact on ground-water quality. For example, if a contaminant is spilled on the surface of the ground or injected into the ground above the water table, it may have to move through numerous layers of soil and other underlying materials before it reaches the ground water. As the contaminant moves through these layers, a number of processes are in operation (e.g., filtration, dilution, oxidation, biological decay) that can lessen the eventual impact of the substance once it finally reaches the ground water. The effectiveness of these processes also is affected by both the distance between the ground water and where the contaminant is introduced and the amount of time it takes the substance to reach the ground water. If the contaminant is introduced directly into the area below the water table, the primary process that can affect the impact of the contaminant is dilution by the surrounding ground water.

GROUND SURFACE	Infiltration of polluted surface water	De-icing salt use & storage
	Land disposal of wastes	Animal feedlots
	Stockpiles	Fertilizers & pesticides
	Dumps	Accidental spills
	Sewage sludge disposal	Airborne source particulates
ABOVE WATER TABLE	Septic tanks, cesspools, & privies	Underground pipeline leaks
	Holding ponds & lagoons	Artificial recharge
	Sanitary landfills	Sumps and dry wells
	Waste disposal in excavations	Graveyards
BELOW WATER TABLE	Underground storage tank leaks	
	Waste disposal in wells	Exploratory wells
	Drainage wells and canals	Abandoned wells
	Underground storage	Water-supply wells
	Mines	Ground-water withdrawal

TABLE 1. Activities That Can Cause Ground-Water Contamination

In comparison with rivers or streams, ground water tends to move very slowly and with very little turbulence. Therefore, once the contaminant reaches the ground water, little dilution or dispersion normally occurs. Instead, the contaminant forms a concentrated plume that can flow along the same path as the ground water. Among the factors that determine the size, form, and rate of movement of the contaminant plume are the amount and type of contaminant and the speed of ground-water movement. Because ground water is hidden from view, contamination can go undetected for years until the supply is tapped for use.

What Kinds of Substances Can Contaminate Groundwater, and Where Do They Come From?

Substances that can contaminate ground water can be divided into two basic categories: substances that occur naturally and substances produced or introduced by man's activities. Substances that occur naturally include minerals such as iron, calcium, and selenium. Substances resulting from man's activities include synthetic organic chemicals and hydrocarbons (e.g., solvents, pesticides, petroleum products); landfill leachates (liquids that have dripped through the landfill and carry dissolved substances from the waste materials), containing such substances as heavy metals and organic decomposition products; salt; bacteria; and viruses. A significant number of today's ground-water contamination problems stem from man's activities and can be introduced into ground water from a variety of sources.

Septic Tanks, Cesspools, and Privies

A major cause of ground-water contamination in many areas of the United States is effluent, or outflow, from septic tanks, cesspools, and privies. Approximately one fourth of all homes in the United States rely on septic systems to dispose of their human wastes. If these systems are improperly sited, designed, constructed, or maintained, they can allow contamination of the ground water by bacteria, nitrates, viruses, synthetic detergents, household chemicals, and chlorides. Although each system can make an insignificant contribution to ground-water contamination, the sheer number of such systems and their widespread use in every area that does not have a public sewage treatment system makes them serious contamination sources.

Surface Impoundments

Another potentially significant source of ground-water contamination is the more than 180,000 surface impoundments (e.g., ponds, lagoons) used by municipalities, industries, and businesses to store, treat, and dispose of a variety of liquid wastes and wastewater. Although these impoundments are supposed to be sealed with compacted clay soils or plastic liners, leaks can and do develop.

Agricultural Activities

Agricultural activities also can make significant contributions to ground-water contamination with the millions of tons of fertilizers and pesticides spread on the ground and from the storage and disposal of livestock wastes. Homeowners, too, can contribute to this type of ground-water pollution with the chemicals they apply to their lawns, rosebushes, tomato plants, and other garden plants.

Landfills

There are approximately 500 hazardous waste land disposal facilities and more than 16,000 municipal and other landfills nationwide. To protect ground water, these facilities are now required to be constructed with clay or synthetic liners and leachate collection systems. Unfortunately, these requirements are comparatively recent, and thousands of landfills were built, operated, and abandoned in the past without such safeguards. A number of these sites have caused serious ground-water contamination problems and are now being cleaned up by their owners, operators, or users; state governments; or the federal government under the Superfund program (see p. 8). In addition, a lack of information about the location of many of these sites makes it difficult, if not impossible, to determine how many others may now be contaminating ground water.

Underground Storage Tanks

Between five and six million underground storage tanks are used to store a variety of materials, including gasoline, fuel oil, and numerous chemicals. The average life span of these tanks is 18 years, and over time, exposure to the elements causes them to corrode. Now, hundreds of thousands of these tanks are estimated to be leaking, and many are contaminating ground water. Replacement costs for these tanks are estimated at \$1 per gallon of storage capacity; a cleanup operation can cost considerably more.

Abandoned Wells

Wells can be another source of ground-water contamination. In the years before there were community water supply systems, most people relied on wells to provide their drinking water. In rural areas this can still be the case. If a well is abandoned without being properly sealed, however, it can act as a direct channel for contaminants to reach ground water.

Accidents and Illegal Dumping

Accidents also can result in ground-water contamination. A large volume of toxic materials is transported throughout the country by truck, train, and airplane.

Every day accidental chemical or petroleum product spills occur that, if not handled properly, can result in ground-water contamination. Frequently, the automatic reaction of the first people at the scene of an accident involving a spill will be to flush the area with water to dilute the chemical. This just washes the chemical into the soil around the accident site, allowing it to work its way down to the ground water. In addition, there are numerous instances of ground-water contamination caused by the illegal dumping of hazardous or other potentially harmful wastes.

Highway De-icing

A similar flushing mechanism also applies to the salt that is used to de-ice roads and highways throughout the country every winter. More than 11 million tons of salt are applied to roads in the United States annually. As ice and snow melt or rain subsequently falls, the salt is washed into the surrounding soil where it can work its way down to the ground water. Salt also can find its way into ground water from improperly protected storage stockpiles.

What Can Be Done After Contamination Has Occurred?

Unlike rivers, lakes, and streams that are readily visible and whose contamination frequently can be seen with the naked eye, ground water itself is hidden from view. Its contamination occurs gradually and generally is not detected until the problem has already become extensive. This makes cleaning up contamination a complicated, costly, and sometimes impossible process.

In general, a community whose ground-water supply has been contaminated has five options:

- * Contain the contaminants to prevent their migration from their source.
- * Withdraw the pollutants from the aquifer.
- * Treat the ground water where it is withdrawn or at its point of use.
- * Rehabilitate the aquifer by either immobilizing or detoxifying the contaminants while they are still in the aquifer.
- * Abandon the use of the aquifer and find alternative sources of water

Which option is chosen by the community is determined by a number of factors, including the nature and extensiveness of the contamination, whether specific actions are required by statute, the geologic conditions, and the funds available for the purpose. All of these options are costly. For example, a community in Massachusetts chose a treatment option when the wells supplying its public water system were contaminated by more than 2,000 gallons of gasoline that had leaked into the ground from an underground storage tank less than 600 feet from one of the wells.

The town temporarily provided alternative water supplies for its residents and then began a cleanup process that included pumping out and treating the contaminated water and then recharging the aquifer with the treated water. The cleanup effort alone cost more than \$3 million. Because of the high costs and technical difficulties involved in the various containment and treatment methods, many communities will choose to abandon the use of the aquifer when facing contamination of their ground-water supplies. This requires the community to either find other water supplies, drill new wells farther away from the contaminated area of the aquifer, deepen existing wells, or drill new wells in another aquifer if one is located nearby. As Atlantic City, New Jersey, found, these options also can be very costly for a community. The wells supplying that city's public water system were contaminated by leachate from a landfill. The city estimated that development of a new wellfield would cost approximately \$2 million.

Government Ground-Water Protection Activities

Given the importance of ground water as a source of drinking water for so many communities and individuals and the cost and difficulty of cleaning it up, common sense tells us that the best way to guarantee continued supplies of clean ground water is to prevent contamination.

Are There Federal Laws or Programs to Protect Ground Water?

The U.S. Environmental Protection Agency (EPA) is responsible for federal activities relating to the quality of ground water. EPA's ground-water protection activities are authorized by a number of laws, including:

- * The Safe Drinking Water Act, which authorizes EPA to set standards for maximum levels of contaminants in drinking water, regulate the underground disposal of wastes in deep wells, designate areas that rely on a single aquifer for their water supply, and establish a nationwide program to encourage the states to develop programs to protect public water supply wells (i.e., wellhead protection programs).

- * The Resource Conservation and Recovery Act, which regulates the storage, transportation, treatment, and disposal of solid and hazardous wastes to prevent contaminants from leaching into ground water from municipal landfills, underground storage tanks, surface impoundments, and hazardous waste disposal facilities.

- * The Comprehensive Environmental Response, Compensation, and Liability Act (Superfund), which authorizes the government to clean up contamination caused by chemical spills or hazardous waste sites that could (or already do) pose threats to the environment, and whose 1986 amendments include provisions authorizing citizens to sue violators of the law and establishing "community right-to-know" programs (Title III).

- * The Federal Insecticide, Fungicide, and Rodenticide Act, which authorizes EPA to control the availability of pesticides that have the ability to leach into ground water.

- * The Toxic Substances Control Act which authorizes EPA to control the manufacture, use, storage, distribution, or disposal of toxic chemicals that have the potential to leach into ground water.

- * The Clean Water Act, which authorizes EPA to make grants to the states for the development of ground-water protection strategies and authorizes a number of programs to prevent water pollution from a variety of potential sources.

The federal laws tend to focus on controlling potential sources of ground-water contamination on a national basis. Where federal laws have provided for general ground-water protection activities such as wellhead protection programs or development of state ground-water protection strategies, the actual implementation of these programs must be by the states in cooperation with local governments. A major reason for this emphasis on local action is that protection of ground water generally involves making very specific decisions about how land is used. Local governments frequently exercise a variety of land-use controls under state laws.

Do the States Have Laws or Programs to Protect Ground Water?

According to a study conducted for EPA in 1988, most of the states have passed some type of ground-water protection legislation and developed some kind of ground-water policies. State ground-water legislation can be divided into the following subject categories:

- * Statewide strategies - Requiring the development of a comprehensive plan to protect the state's ground-water resources from contamination.

- * Ground-water classification - Identifying and categorizing ground-water sources by how they are used to determine how much protection is needed to continue that type of use.

- * Standard setting - Identifying levels at which an aquifer is considered to be contaminated.

- * Land-use management - Developing planning and regulatory mechanisms to control activities on the land that could contaminate an aquifer.
- * Ground-water funds - Establishing specific financial accounts for use in the protection of ground-water quality and the provision of compensation for damages to underground drinking water supplies (e.g., reimbursement for ground-water cleanup, provision of alternative drinking water supplies).
- * Agricultural chemicals - Regulating the use, sale, labeling, and disposal of pesticides, herbicides, and fertilizers.
- * Underground storage tanks - Establishing criteria for the registration, construction, installation, monitoring, repair, closure, and financial responsibility associated with tanks used to store hazardous wastes or materials.
- * Water-use management - Including ground-water quality protection in the criteria used to justify more stringent water allocation measures where excessive ground-water withdrawal could cause ground-water contamination.

Appendix 1 presents a matrix showing the types of ground-water protection legislation enacted by the states. In addition to ground-water protection programs states may have developed under their own laws, one state ground-water protection program is required by federal law. The 1986 amendments to the Safe Drinking Water Act established the wellhead protection program and require each state to develop comprehensive programs to protect public water supply wells from contaminants that could be harmful to human health. Wellhead protection is simply protection of all or part of the area surrounding a well from which the well's ground water is drawn. This is called a wellhead protection area (WHPA). The size of the WHPA will vary from site to site depending on a number of factors, including the goals of the state's program and the geologic features of the area.

The law specifies certain minimum components for the wellhead protection programs:

- * The roles and duties of state and local governments and public water suppliers in the management of wellhead protection programs must be established.
- * The WHPA for each wellhead must be delineated (i.e., outlined or defined).
- * Contamination sources within each WHPA must be identified.
- * Approaches for protecting the water supply within the WHPAs from the contamination sources (e.g., use of source controls, education, training) must be developed.
- * Contingency plans must be developed for use if public water supplies become contaminated.
- * Provisions must be established for proper siting of new wells to produce maximum water yield and reduce the potential for contamination as much as possible.
- * Provisions must be included to ensure public participation in the process.

For a program to be successful, all levels of government must participate in the wellhead protection program. The federal government is responsible for approving state wellhead protection programs and for providing technical support to state and local governments. State governments must develop and implement wellhead protection programs that meet the requirements of the Safe Drinking Water Act. Although the responsibilities of local governments depend on the specific requirements of their state's program, these governments often are in the best position (and have the greatest incentive) to ensure proper protection of wellhead areas. They have the most to lose if their ground-water becomes contaminated.



Well Development Section

Once well construction is complete, the well is *developed*. The purpose of well development is to *purge* the well and bore of all drilling mud and or fluid, fine grained sediment, and loose aquifer matter.

The well development process also helps to settle the gravel or filter pack and/or rearrange particles within the well and nearby aquifer to allow for the most efficient operation of the well. Not surprisingly, the drilling procedure often damages the aquifer around the well.

Well development can significantly improve a well's performance by essentially repairing as much of this damage as possible by improving the transition from the aquifer to the well. The screened and productive portions of the well can be subjected to various development techniques.

All methods of well development essentially involve the flushing of water back and forth between the well and aquifer.

If you think of the aquifer as one great big *natural media filter*, the development process to a well is much the same as the backwashing process for a water treatment system. So what about hard rock wells? Wells constructed in hard rock aquifers are not composed of unconsolidated sediments. Still, they can and should be developed because fine cuttings, drilling mud, and clay within the *fractures* and *pore spaces* near the well can obstruct flow from otherwise productive zones.

Well development procedures can remove such sediments from hard rock wells also. Several common methods of well development include, surge-block, jetting, airlift, and pump surging.

Well Surging or Backwashing

Pump surging (sometimes called **Rawhiding**) involves the repeated pumping and resting of the well for well development purposes. A column of water that is withdrawn through a pump is allowed to surge back into the well by turning the pump on and off repeatedly. However, sufficient time for the pump motor to stop reverse rotation must be allowed, such that pump damage can be avoided. Occasionally, water is pumped to waste until it is clear of sediment before again shutting the pump off. This is done to permanently remove the sediments that are being developed by the backwashing action. The process continues until sufficient quantities of water produced are consistently clean.

Surge-blocks, swabs, or plungers are disc shaped devices made to fit tightly within the well. Their edges are usually fitted with rubber or leather rings to make a tight seal against the well casing. Pipe sections are then attached to the surge-block to lower it into the well, above the well screen, and about 15 feet below the water level. The assembly is then repeatedly lifted up and down. The up and down action of the surge-block creates suction, and compression strokes that force water in and out of the well through the screened interval, gravel pack, and aquifer. It works like a plunger in the way that it removes small obstructions and sediments from the well. The surge-block is slowly lowered each time resistance begins to decrease.

Once the top of the screen is reached, the assembly may be removed and accumulated sediment either bailed or airlifted out of the well. Surging within known problem areas of the screened interval may be conducted also. The cycle of swabbing and removing sediment should be continued until resistance to the action of the swab or block is significantly lower than at the start of development. The development is complete when the amount of sediment removed is both significantly and consistently less than when surging began.

Airlifting (or **Air surging**) involves the introduction of large short blasts of air within the well that lifts the column of water to the surface and then drop it back down again. Continuous airlifting or **air pumping** from the bottom of the well is then used occasionally to lift sediments out of the well. Airlift development is most often used following initial pump surging, and is employed to confirm that the well is productive, since the injection of air into a plugged well may result in casing or screen failure.

Air lifting development is most often done with a rotary drilling rig through the drill string. Sometimes special air diffusers or jets are used to direct the bursts of air into preferred directions (see jetting). Piping is inserted into the well and intermittent blasts of air are introduced as the piping is slowly lowered into the well. Sometimes surfactant or drill foam is added to aid in the efficiency of sediment removal and cleaning of the well. Air surging development is much the same as drilling the well with air rotary; only the well has already been constructed. Specialized air development units are available independent of a drilling rig, which may be used as well. The great thing about air rotary drilled wells is that they are essentially developed while drilling, particularly in hard rock formations, when greater than 100 gallons per minute is being lifted to the surface. The development of a filter pack (if used) in such wells is still recommended.

Jetting is a type of well development technique in which water and/or air is *jetted* or sprayed horizontally into the well screen. This method is especially suited for application in *stratified* and *unconsolidated* formations. The water or air is forced through *nozzles* in a specially designed *jetting tool* (or simply drilled pipe and fittings) at high velocities. Normally, air lifting or pumping is used in conjunction with jetting methods in order to minimize potential damage to the well bore. Jetting with water alone can be so powerful that the sediment, which is supposed to be removed, can be forced into the formation causing clogging problems.

This is why pumping or airlifting while jetting with water is so important. Jetting is normally conducted from the bottom of the well screen upwards.

Rotary Rig

A rotary rig is often used to provide the fluid or air with sustained pressure while the tool is slowly raised up through the screen. As jetting proceeds, sediment is occasionally removed from the bottom of the well bore thru the use of a bailer or airlifting. Several passes should be made over the length of screen until sediment generation drops off. Air is normally used for jetting in shallow aquifers (less than 300 feet of submergence) due to limited supply pressures. Jetting in PVC constructed wells is not recommended since the high velocities of fluid and sediment can erode and possibly cut through the plastic well screen. In addition, wells constructed with louvered or slotted screen limit the effectiveness of jetting. In these types of wells, surging may be more effective.

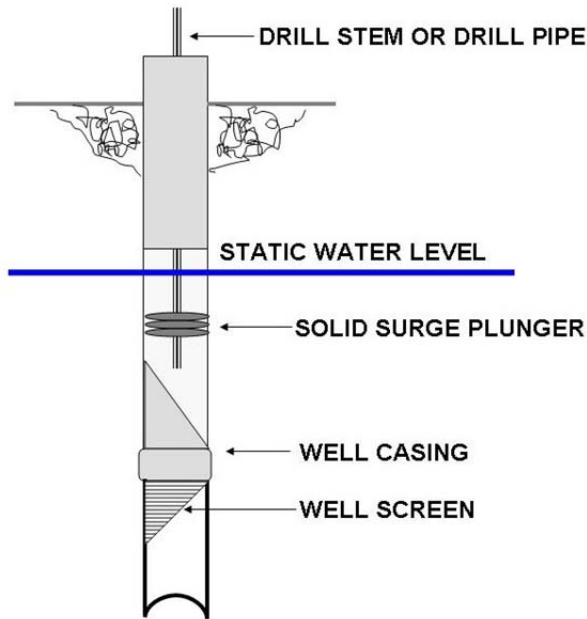

Surge of air developing a Well.

Jetting Nozzle that can be → attached to drill pipe.

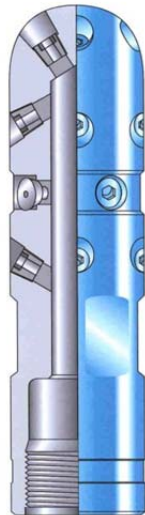

In the best of situations a combination of methods can be used to ensure the efficient development and operation of a well.

Selecting an Optimum Pumping Rate

Before a well can be completed with the necessary pumping equipment, it should be tested for capacity and proper operation. When the well was drilled, the driller and geologist kept close watch of the amount of water production that had been obtained. The development techniques used can also be useful in estimating a well's production rate. However, the driller will normally know what to expect based on his experience, and the geologist or *hydrologist* will also obtain information on other nearby wells to bracket the expected production rate. If the well was drilled with air rotary, the *airlift* at the time of drilling also can serve as a baseline to estimate the well's production rate. Either way, the well is normally pump tested following well development.

A *pumping test* is normally conducted for at least eight hours in order to estimate a well's maximum production rate. Ideally, a twenty-four hour step test is conducted. A step test is a *variable rate* pumping test, typically conducted for 24 hours at up to six different pumping rates. Typically, the well will be pumped at the lower estimated maximum pumping rate for the first four hours.

The pumping rate is then adjusted upwards in equal amounts every four hours until 24 hours of pumping have been completed. The personnel conducting the test keep track of the water levels in the well to ensure that the steps are not too large and not too small.

In the end, the optimum pumping rate is selected following a careful review and comparison of the water level data for each rate. The well's *specific capacity* (Sc) is then determined. Specific capacity is the gallons per minute the well can produce per foot of drawdown. Specific capacities for each of the pumping steps are compared. The highest Sc observed is normally associated with the optimum pumping rate. That rate should also have resulted in *stabilized* pumping levels or *drawdown*.



Well pumping test being conducted in photograph above. (Notice the portable electric generator for powering the pump. The Hydrogeologist is using a depth probe to measure the drop in the static water level.)

Selection of Pumping Equipment

The proper selection of pumping equipment for a well is of great importance. The primary factors that must be considered before selecting the well pump are: flow rate, line pressure, pumping lift (total dynamic head), power requirements (and limitations), and size of piping. Each of these components must be considered together when selecting well pumps.

Pumping Lift and Total Dynamic or Discharge Head

The most important components in selecting the correct pump for your application are: *total pumping lift* and *total dynamic or discharge head*. Total dynamic head refers to the total equivalent feet of lift that the pump must overcome in order to deliver water to its destination, including frictional losses in the delivery system.

Basic Pump Operating Characteristics

"Head" is a term commonly used with pumps. Head refers to the height of a vertical column of water. Pressure and head are interchangeable concepts in irrigation, because a column of water 2.31 feet high is equivalent to 1 pound per square inch (PSI) of pressure. The total head of a pump is composed of several types of head that help define the pump's operating characteristics.

Total Dynamic Head

The total dynamic head of a pump is the sum of the total static head, the pressure head, the friction head, and the velocity head.

The Total Dynamic Head (TDH) is the sum of the total static head, the total friction head and the pressure head.

Total Static Head

The total static head is the total vertical distance the pump must lift the water. When pumping from a well, it would be the distance from the pumping water level in the well to the ground surface plus the vertical distance the water is lifted from the ground surface to the discharge point. When pumping from an open water surface, it would be the total vertical distance from the water surface to the discharge point.

Pressure Head

The pressure head at any point where a pressure gauge is located can be converted from pounds per square inch (PSI) to feet of head by multiplying by 2.31. For example, 20 PSI is equal to 20 times 2.31 or 46.2 feet of head. Most city water systems operate at 50 to 60 PSI, which, as illustrated in Table 1, explains why the centers of most city water towers are about 130 feet above the ground.

Table 1. Pounds per square inch (PSI) and equivalent head in feet of water.

PSI	Head (feet)
0	0
5	11.5
10	23.1
15	34.6
20	46.2
25	57.7

30	69.3
35	80.8
40	92.4
45	104
50	115
55	127
60	138
65	150
70	162
75	173
80	185
85	196
90	208
95	219
100	231

Friction Head

Friction head is the energy loss or pressure decrease due to friction when water flows through pipe networks. The velocity of the water has a significant effect on friction loss. Loss of head due to friction occurs when water flows through straight pipe sections, fittings, valves, around corners, and where pipes increase or decrease in size. Values for these losses can be calculated or obtained from friction loss tables. The friction head for a piping system is the sum of all the friction losses.

Velocity Head

Velocity head is the energy of the water due to its velocity. This is a very small amount of energy and is usually negligible when computing losses in an irrigation system.

Suction Head

A pump operating above a water surface is working with a suction head. The suction head includes not only the vertical suction lift, but also the friction losses through the pipe, elbows, foot valves, and other fittings on the suction side of the pump. There is an allowable limit to the suction head on a pump and the net positive suction head (NPSH) of a pump sets that limit.

The theoretical maximum height that water can be lifted using suction is 33 feet. Through controlled laboratory tests, manufacturers determine the NPSH curve for their pumps. The NPSH curve will increase with increasing flow rate through the pump. At a certain flow rate, the NPSH is subtracted from 33 feet to determine the maximum suction head at which that pump will operate. For example, if a pump requires a minimum NPSH of 20 feet the pump would have a maximum suction head of 13 feet. Due to suction pipeline friction losses, a pump rated for a maximum suction head of 13 feet may effectively lift water only 10 feet. To minimize the suction pipeline friction losses, the suction pipe should have a larger diameter than the discharge pipe.

Operating a pump with suction lift greater than it was designed for, or under conditions with excessive vacuum at some point in the impeller, may cause cavitation. Cavitation is the implosion of bubbles of air and water vapor and makes a very distinct noise like gravel in the pump. The implosion of numerous bubbles will eat away at an impeller and it eventually will be filled with holes.

Pump Power Requirements

The power added to water as it moves through a pump can be calculated with the following formula:

$$\text{WHP} = \frac{Q \times \text{TDH}}{3960} \quad (1)$$

where:

WHP = Water Horse Power
Q = Flow rate in gallons per minute (GPM)
TDH = Total Dynamic Head (feet)

However, the actual power required to run a pump will be higher than this because pumps and drives are not 100 percent efficient. The horsepower required at the pump shaft to pump a specified flow rate against a specified TDH is the **Brake Horsepower** (BHP) which is calculated with the following formula:

$$\text{BHP} = \frac{\text{WHP}}{\text{Pump Eff.} \times \text{Drive Eff.}} \quad (2)$$

BHP -- Brake Horsepower (continuous horsepower rating of the power unit).

Pump Eff. -- Efficiency of the pump usually read from a pump curve and having a value between 0 and 1.

Drive Eff. -- Efficiency of the drive unit between the power source and the pump. For direct connection this value is 1, for right angle drives the value is 0.95 and for belt drives it can vary from 0.7 to 0.85.

Effect of Speed Change on Pump Performance

The performance of a pump varies with the speed at which the impeller rotates.

Theoretically, varying the pump speed will result in changes in flow rate, TDH and BHP according to the following formulas:

$$\left(\frac{\text{RPM}_2}{\text{RPM}_1}\right) \times \text{GPM}_1 = \text{GPM}_2 \quad (3)$$

$$\left(\frac{\text{RPM}_2}{\text{RPM}_1}\right)^2 \times \text{TDH}_1 = \text{TDH}_2 \quad (4)$$

$$\left(\frac{\text{RPM}_2}{\text{RPM}_1}\right)^3 \times \text{BPH}_1 = \text{BPH}_2 \quad (5)$$

where:

RPM_1 = Initial revolutions per minute setting

RPM_2 = New revolutions per minute setting

GPM = Gallons per Minute
(subscripts same as for RPM)

TDH = Total Dynamic Head
(subscripts same as for RPM)

BHP = Brake Horsepower
(subscripts same as for RPM)

As an example, if the RPM are increased by 50 percent, the flow rate will increase by 50 percent, the TDH will increase 2.25 times, and the required BHP will increase 3.38 times that required at the lower speed. It is easy to see that with a speed increase the BHP requirements of a pump will increase at a **faster rate** than the head and flow rate changes.

Pump Efficiency

Manufacturers determine by tests the operating characteristics of their pumps and publish the results in pump performance charts commonly called "**pump curves.**"

A typical pump curve for a horizontal centrifugal pump. NPSH is the Net Positive Suction Head required by the pump and TDSL is the Total Dynamic Suction Lift available (both at sea level).

All pump curves are plotted with the flow rate on the horizontal axis and the TDH on the vertical axis. The curves in a pump curve are for a centrifugal pump tested at different RPM. Each curve indicates the GPM versus TDH relationship at the tested RPM. In addition, pump efficiency lines have been added and wherever the efficiency line crosses the pump curve lines **that** number is what the efficiency is at that point. Brake horsepower (BHP) curves have also been added; they slant down from left to right. The BHP curves are calculated using the values from the efficiency lines. At the top of the chart is an NPSH curve with its scale on the right side of the chart.

Reading a Pump Curve

When the desired flow rate and TDH are known, these curves are used to select a pump. The pump curve shows that a pump will operate over a wide range of conditions. However, it will operate at peak efficiency only in a narrow range of flow rate and TDH. As an example of how a pump characteristic curve is used, let's use the pump curve to determine the horsepower and efficiency of this pump at a discharge of 900 gallons per minute (**GPM**) and 120 feet of TDH.

Solution: Follow the dashed vertical line from 900 GPM until it crosses the dashed horizontal line from the 120 feet of TDH. At this point the pump is running at a peak efficiency just below 72 percent, at a speed of 1600 RPM. If you look at the BHP curves, this pump requires just less than 40 BHP on the input shaft. A more accurate estimate of BHP can be calculated with equations 1 and 2. Using equation 1, the WHP would be $[900 \times 120] / 3960$ or 27.3, and from equation 2 the BHP would be $27.3 / 0.72$ or 37.9, assuming the drive efficiency is 100 percent. The NPSH curve was used to calculate the Total Dynamic Suction Lift (TDSL) markers at the bottom of the chart. Notice that the TDSL at 1400 GPM is 10 feet, but at 900 GPM the TDSL is over 25 feet.

Changing Pump Speed

In addition, suppose this pump is connected to a diesel engine. By varying the RPM of the engine we can vary the flow rate, the TDH and the BHP requirements of this pump. As an example, let's change the speed of the engine from 1600 RPM to 1700 RPM. What effect does this have on the GPM, TDH and BHP of the pump?

Solution: We will use equations 3, 4 and 5 to calculate the change. Using equation 3, the change in GPM would be $(1700/1600) \times 900$, which equals 956 GPM. Using equation 4, the change in TDH would be $(1700/1600)^2 \times 120$, which equals 135.5 feet of TDH. Using equation 5, the change in BHP would be $(1700/1600)^3 \times 37.9$, which equals 45.5 BHP. This point is plotted on Figure 2 as the circle with the dot in the middle. Note that the new operating point is up and to the right of the old point and that the efficiency of the pump has remained the same.

When a pump has been selected for installation, a copy of the pump curve should be provided by the installer. In addition, if the impeller(s) was trimmed, this information should also be provided. This information will be valuable in the future, especially if repairs have to be made.

Determining Friction Losses

A well system installer and/or engineer can help in determining the friction losses in the distribution system. There are numerous friction loss tables with values of equivalent feet of head for given flow rates and types and diameters of pipe available. However, unless great distances or small diameter pipes are used, friction loss is almost negligible. The lift requirements for the pump primarily include the height to which the pump must deliver the water from the wellhead, plus the distance from the pumping level to the land surface.

For example: A municipal supply well has been tested and determined to yield 500gpm. The well was constructed with 10 inch casing that has been perforated from 200 to 500 feet below the ground surface within an unconfined aquifer. The static water level has been measured at 100 feet while the drawdown at 500gpm has been estimated at 80 feet. The full level of the storage tank for the well exerts about 87psi at the wellhead and is connected to the well via a 12-inch distribution main. Three-phase power is available and 4-inch column pipe is to be used down the hole. The pump intake is to be set at 180 feet.

Before we can select an appropriate pump, we first need to determine what the total dynamic head is. After referring to a friction loss table for flow in 4 inch and 12-inch pipe; we determine that the friction losses in the 4 inch pipe will be about 24 feet per 100 foot, while losses in the 12 inch main are negligible.

This leads us to determine that there will be about 43 feet of friction loss through the 4-inch pipe. We also know that the total lift is equal to the drawdown, plus the distance to the land surface from the static water level, plus the vertical distance to the full level of the storage tank. We know from physics that for every foot of water there is .433psi of pressure or 2.31ft of head for every 1 psi. The line pressure at the well head is equal to the height of the column of water above the well head, which gives us a line pressure at the well head of 87psi or 200 feet of water. The total lift from the pump to the wellhead 180 feet and equivalent to 78psi. So the total dynamic head is equivalent to a lift of 380 feet or an equivalent pressure of about 165psi at the pump, plus about 43 feet of friction loss. Therefore, in order to pump 500gpm under these circumstances, the pump that is selected should have its most efficient operating range in the neighborhood of 423 feet total lift. We then look at *performance*

curves from the various pump manufacturers to determine the best pump and power combination for the application.

Because this is a municipal supply well that is pumping directly into the distribution system, we will choose a submersible turbine for the job rather than a line shaft turbine, which must be lubricated. Upon looking at the curves for this application, one will find that a 75HP, 8in, 5 stage, submersible pump will do the job most efficiently without risking the over-pumping of the well.

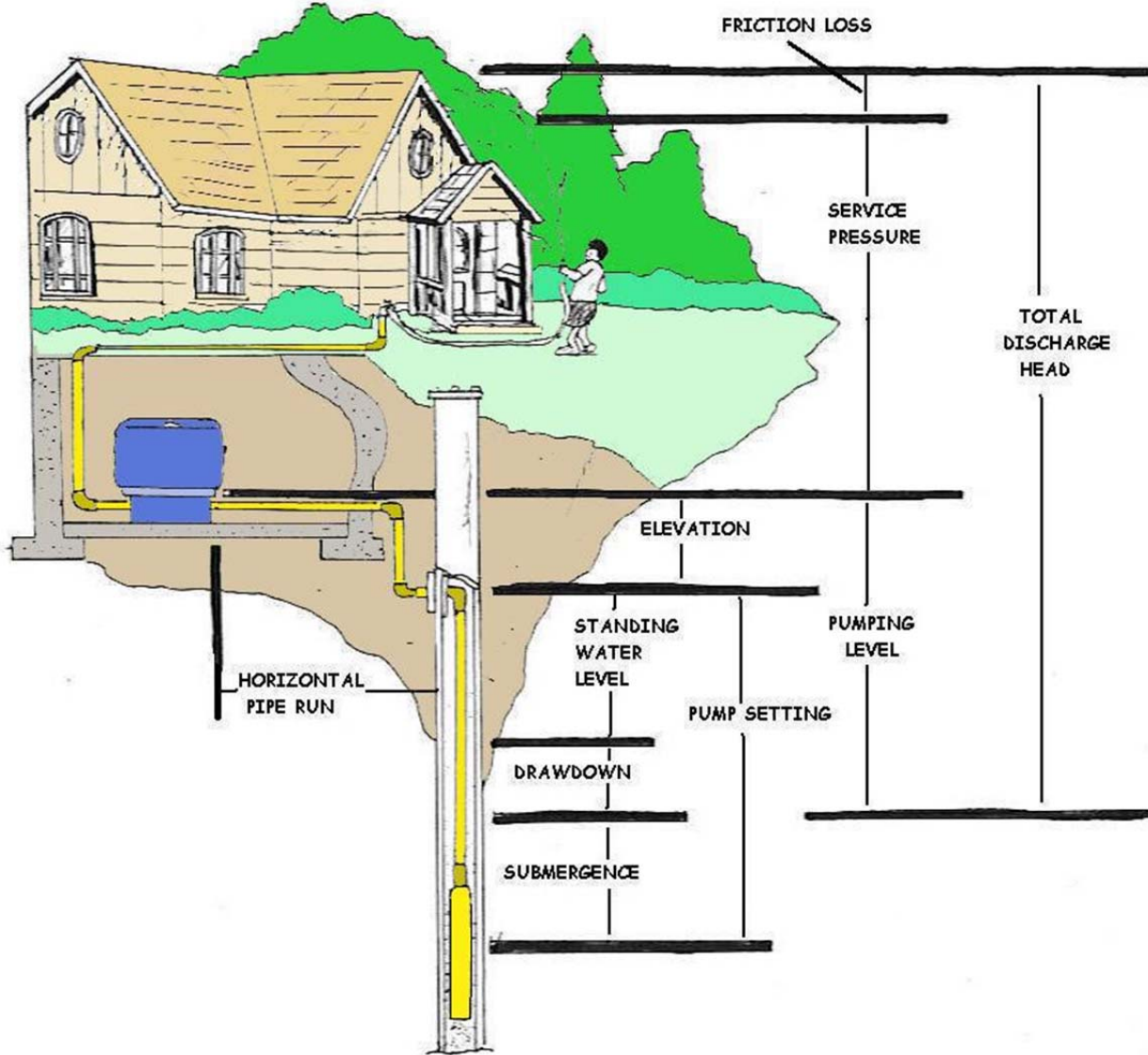

Elements of Total Dynamic Head for the proper selection of pumping equipment.



A new 8 inch submersible pump and motor with 6 inch column pipe about to be installed in a high capacity municipal supply well.

The Well Head Assembly

An approved well cap or seal is to be installed at the *wellhead* to prevent any contamination from entering the well through the top once construction is complete. When the well is completed with pumping equipment a well vent is also required.

The well *vent pipe* should be at least $\frac{1}{2}$ inch in diameter, 8 inches above the finished grade, and be turned down, with the opening screened with a minimum 24-mesh durable screen to prevent entry of insects. Only approved well casing material meeting the requirements of the Code may be utilized.

In addition, frost protection should be provided by use of insulation or pump house. Turbine and submersible pumps are normally used. Any pressure, vent, and electric lines to and from the pump should enter the casing only through a watertight seal.

Pumps and pressure tanks may be located in basements and enclosures. However, wells should not be located within vaults or pits, except with a *variance permit*.

If the pump discharge line passes through the well casing underground, an approved *pitless adapter* should be installed. The *well manifold* should include an air relief valve, flow meter, sample port, isolation valve, and a check valve. If the well should need rehabilitation, additional construction, or repair, it must be done in compliance with the State or Local Water Well Construction Codes.

Water Storage Section

Water storage facilities and tanks vary in size, shape, and application. There are different types that are used in the water distribution systems, such as standpipes, elevated tanks and reservoirs, hydropneumatic tanks and surge tanks.

These tanks serve multiple purposes in the distribution system. Just the name alone can give you an idea of its purpose.

- **SURGE tanks**
- **RESERVOIRS**
- **ELEVATED tanks** *Water towers and Standpipes*

Surge Tanks

What really causes water main breaks - **ENERGY** - when released in a confined space, such as a water distribution system. Shock waves are created when hydrants, valves, or pumps are opened and closed quickly, trapping the kinetic energy of moving water within the confined space of a piping system.

These shock waves can create a turbulence that travels at the speed of sound, seeking a point of release. The release the surge usually finds is an elevated tank, but the surge doesn't always find this release quickly enough. Something has to give, often times, it's your pipe fittings.

Distribution operators are aware of this phenomenon! It's called **WATER HAMMER**.

This banging can be heard as water hammer. Try it at home - turn on your tap, then turn it off very quickly. You should hear a bang, and maybe even several. If you turn the tap off more slowly, it should stay quiet, as the liquid in the pipes slows down more gradually.

A Surge tank should not be used for water storage.

The goal of the water tower or standpipe is to store water high in the air, where it has lots of gravitational potential energy. This stored energy can be converted to pressure potential energy or kinetic energy for delivery to homes. Since height is everything, building a cylindrical water tower is inefficient. Most of the water is then near the ground. By making the tower wider near the top, it puts most of its water high up.



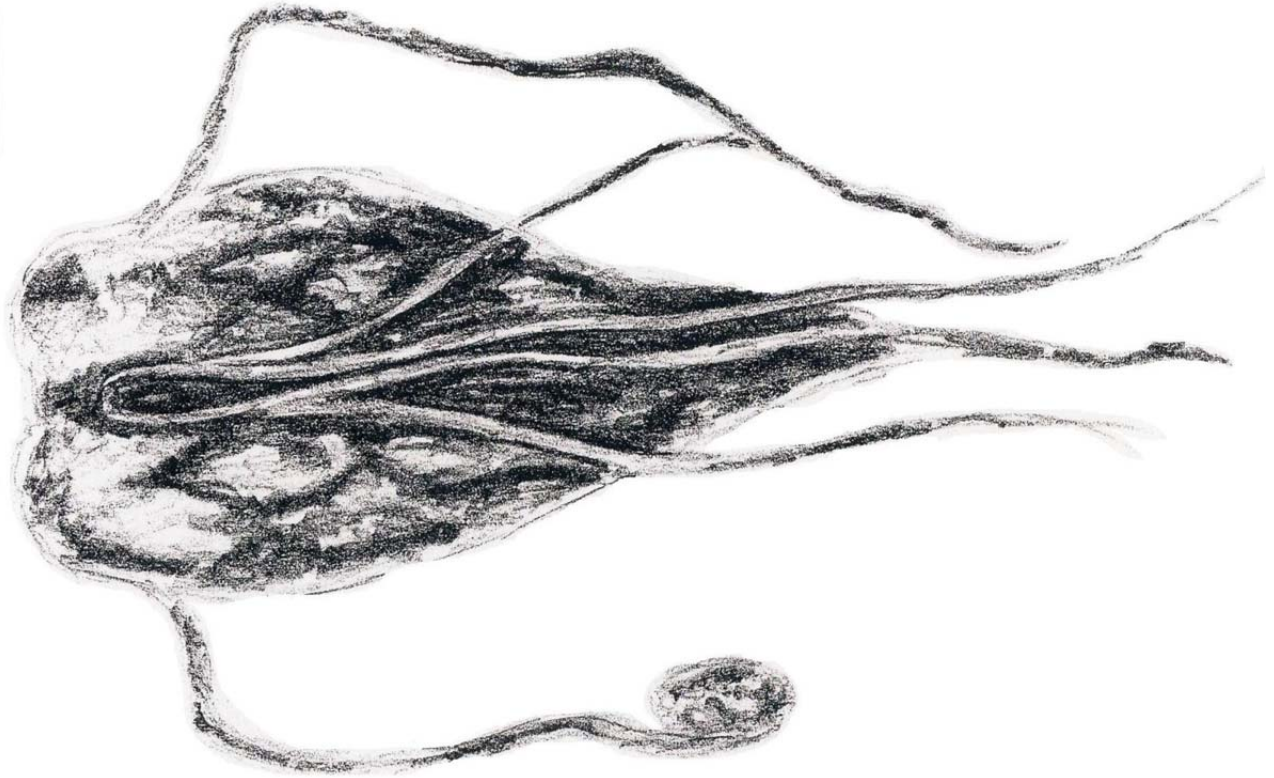

Giardia



Cryptosporidium

Water Quality Key Words Chapter 5

2,4-D: A chlorinated phenoxy compound, functions as a systemic herbicide and is used to control many types of broadleaf weeds. There are many forms or derivatives (esters, amines, salts) of 2,4-D and these vary in solubility and volatility. Unless otherwise specified, this document will refer to the acid form of 2,4-D. This compound is used in cultivated agriculture and in pasture and rangeland applications, forest management, home and garden situations and for the control of aquatic vegetation. 2,4-D was a major component (about 50%) of the product Agent Orange used extensively throughout Vietnam. However most of the problems associated with the use of Agent Orange were associated with a contaminant (dioxin) in the 2,4,5-T component of the defoliant. The association of 2,4-D with Agent Orange has prompted a vast amount of study on the herbicide.

ANTIMONY: A chemical element with the symbol Sb (Latin: stibium, meaning "mark") and atomic number 51. A metalloid, antimony has four allotropic forms. The stable form of antimony is a blue-white metalloid. Yellow and black antimony are unstable non-metals. Antimony is used in flame-proofing, paints, ceramics, enamels, a wide variety of alloys, electronics, and rubber.

ASBESTOS: A mineral fiber that has been used commonly in a variety of building construction materials for insulation and as a fire-retardant. EPA and CPSC have banned several asbestos products. Manufacturers have also voluntarily limited uses of asbestos. Today, asbestos is most commonly found in older homes, in pipe and furnace insulation materials, asbestos shingles, millboard, textured paints and other coating materials, and floor tiles.

BARIUM: A chemical element. It has the symbol Ba, and atomic number 56. Barium is a soft silvery metallic alkaline earth metal. It is never found in nature in its pure form due to its reactivity with air. Its oxide is historically known as baryta but it reacts with water and carbon dioxide and is not found as a mineral. The most common naturally occurring minerals are the very insoluble barium sulfate, BaSO₄ (barite), and barium carbonate, BaCO₃ (witherite). Benitoite is a rare gem containing barium.

BERYLLIUM: A chemical element with the symbol Be and atomic number 4. A bivalent element, beryllium is a steel grey, strong, light-weight yet brittle alkaline earth metal. It is primarily used as a hardening agent in alloys, most notably beryllium copper. Commercial use of beryllium metal presents technical challenges due to the toxicity (especially by inhalation) of beryllium-containing dusts.

BROMATE: An inorganic anion, bromate is tasteless and colorless, with a low volatility. As a moderately strong oxidant, bromate is reactive. BrO₃⁻ is a bromine-based oxoanion. A bromate is a chemical compound that contains this ion. Examples of bromates include sodium bromate, (NaBrO₃), and potassium bromate, (KBrO₃).

CADMIUM: A chemical element with the symbol Cd and atomic number 48. A relatively abundant, soft, bluish-white, transition metal, cadmium is known to cause cancer and occurs with zinc ores. Cadmium is used largely in batteries and pigments, for example in plastic products.

CHLORITE: The chlorite ion is ClO₂⁻. A chlorite (compound) is a compound that contains this group, with chlorine in oxidation state +3. Chlorites are also known as salts of chlorous acid.

CHROMIUM: A chemical element which has the symbol Cr and atomic number 24. It is a steel-gray, lustrous, hard metal that takes a high polish and has a high melting point. It is also odorless, tasteless, and malleable.

CONFINED AQUIFER: A water-bearing stratum that is confined or overlain by a rock layer that does not transmit water in any appreciable amount or that is impermeable.

DISINFECTION BYPRODUCTS: Disinfection byproducts are chemical, organic and inorganic substances that can form during a reaction of a disinfectant with naturally present organic matter in the water.

DPD METHOD: Presence of free chlorine in the distribution network is indication of correct disinfection. Chlorine in water is determined according to ISO 7393-2 by colorimetric HACH method on the basis of DPD (N, N-diethyl - p - phenylendiamine). The photometric detection uses the wave lengths of 490 – 555 nm. Hach elected, for most of his DPD colorimetric systems, the wave length of 530 nm.

FORMAZIN TURBIDITY UNIT (FTU): A unit used to measure the clarity of water. The ISO refers to the units as FNU (Formazin Nephelometric Units). The technique is the same as that for the NTU, but the calibration uses microspheres of the polymer formazin.

HALOACETIC ACIDS: Haloacetic acids are carboxylic acids in which a halogen atom takes the place of a hydrogen atom in acetic acid. Thus, in a monohaloacetic acid, a single halogen would replace a hydrogen atom. For example, chloroacetic acid would have the structural formula $\text{CH}_2\text{ClCO}_2\text{H}$. In the same manner, in dichloroacetic acid two chlorine atoms would take the place of two hydrogen atoms ($\text{CHCl}_2\text{CO}_2\text{H}$).

HIGH-TEST HYPOCHLORITE: A composition composed mainly of calcium hypochlorite is commonly called high test hypochlorite. High-Test Hypochlorite contains not less than 60.0% of available chlorine.

HYDROCHLORIC ACID: It is the aqueous solution of hydrogen chloride gas (HCl). It is a strong acid, and the major component of gastric acid, and of wide industrial use. Hydrochloric acid must be handled with appropriate safety precautions because it is a highly corrosive liquid.

INFORMATION COLLECTION RULE (ICR): EPA collected data required by the Information Collection Rule (May 14, 1996) to support future regulation of microbial contaminants, disinfectants, and disinfection byproducts. The rule was intended to provide EPA with information on chemical byproducts that form when disinfectants used for microbial control react with chemicals already present in source water (disinfection byproducts (DBPs)); disease-causing microorganisms (pathogens), including *Cryptosporidium*; and engineering data to control these contaminants.

IRON BACTERIA: In the management of water-supply wells, iron bacteria are bacteria that derive the energy they need to live and multiply by oxidizing dissolved ferrous iron (or the less frequently available manganese and aluminum). The resulting ferric oxide is insoluble, and appears as brown gelatinous slime that will stain plumbing fixtures, and clothing or utensils washed with the water carrying it, and may contribute to internal corrosion of the pipes and fixtures the water flows through. They are known to grow and proliferate in waters containing as low as 0.1mg/l of iron. However, at least 0.3 ppm of dissolved oxygen is needed to carry out oxidation. The proliferation of iron bacteria, in some way, increases the chance of sulfur bacteria infestation.

LETHAL CONCENTRATION 50: Also referred to as LC50, a concentration of a pollutant or effluent at which 50 percent of the test organisms die; a common measure of acute toxicity.

MANGANESE (IV) OXIDE: The chemical compound MnO_2 , commonly called manganese dioxide. This blackish or brown solid occurs naturally as the mineral pyrolusite, which is the main ore of manganese. It is also present in manganese nodules. The principal use for MnO_2 is for dry-cell batteries, such as the alkaline battery and the zinc-carbon battery. In 1976 this application accounted for 500,000 tons of pyrolusite. MnO_2 is also used for production of MnO_4^- . It is used extensively as an oxidizing agent in organic synthesis, for example, for the oxidation of allylic alcohols.

MAXIMUM CONTAMINANT LEVEL (MCL): The maximum concentration of a chemical that is allowed in public drinking water systems.

MAXIMUM CONTAMINANT LEVEL GOAL (MCLG): The maximum level at which a contaminant can exist in drinking water without having an adverse effect on human health.

NEPHELOMETRIC TURBIDITY UNIT (NTU): The unit used to describe turbidity. Nephelometric refers to the way the instrument, a nephelometer, measures how much light is scattered by suspended particles in the water. The greater the scattering, the higher the turbidity. Therefore, low NTU values indicate high water clarity, while high NTU values indicate low water clarity.

PERMEABLE REACTIVE BARRIER: A permeable reactive barrier (**PRB**) is a permeable zone containing or creating a reactive treatment area oriented to intercept and remediate a contaminant plume. It removes contaminants from the ground-water flow system in a passive manner by physical, chemical or biological processes. Some PRBs are installed as permanent or semi-permanent units across the flow path of a contaminant plume. Some PRB's are installed as in situ reactors which are readily accessible to facilitate the removal/replacement of reactive media. Most have the reactive media installed or created in intimate contact with the surrounding aquifer material.

PERMISSIBLE EXPOSURE LIMIT (PEL or OSHA PEL): A legal limit in the United States for exposure of an employee to a substance or physical agent. For substances it is usually expressed in parts per million (ppm), or sometimes in milligrams per cubic meter (mg/m^3). Units of measure for physical agents such as noise are specific to the agent. Permissible Exposure Limits are established by the Occupational Safety and Health Administration (OSHA).

POLYCHLORINATED BIPHENYLS: Polychlorinated biphenyls (**PCBs**) are a class of organic compounds with 1 to 10 chlorine atoms attached to biphenyl which is a molecule composed of two benzene rings each containing six carbon atoms. The chemical formula for all PCBs is $\text{C}_{12}\text{H}_{10-x}\text{Cl}_x$.

POLYCYCLIC AROMATIC HYDROCARBONS: Polycyclic aromatic hydrocarbons (**PAHs**) are chemical compounds that consist of fused aromatic rings and do not contain heteroatoms or carry substituents. PAHs occur in oil, coal, and tar deposits, and are produced as byproducts of fuel burning (whether fossil fuel or biomass). As a pollutant, they are of concern because some compounds have been identified as carcinogenic, mutagenic, and teratogenic.

POWDERED ACTIVATED CARBON TREATMENT (PACT): A wastewater technology in which powdered activated carbon is added to an anaerobic or aerobic treatment system. The carbon in the biological treatment process acts as a "buffer" against the effects of toxic organics in the wastewater.

PPM: Abbreviation for parts per million.

QUICKLIME: A calcium oxide material produced by calcining limestone to liberate carbon dioxide, also called "calcined lime" or "pebble lime", commonly used for pH adjustment. Chemical formula is CaO .

RECOMMENDED EXPOSURE LIMIT (REL): An occupational exposure limit that has been recommended by the U.S. National Institute for Occupational Safety and Health to OSHA for adoption as a Permissible Exposure Limit. The REL is a level that NIOSH believes would be protective of worker safety and health over a working lifetime if used in combination with engineering and work practice controls, exposure and medical monitoring, posting and labeling of hazards, worker training and personal protective equipment. No REL has ever been adopted by OSHA, but they have been used as guides by some industry and advocacy organizations.

REDOX: Redox (shorthand for reduction/oxidation reaction) describes all chemical reactions in which atoms have their oxidation number (oxidation state) changed. This can be either a simple redox process such as the oxidation of carbon to yield carbon dioxide, or the reduction of carbon by hydrogen to yield methane (CH_4), or it can be a complex process such as the oxidation of sugar in the human body through a series of very complex electron transfer processes. The term redox comes from the two concepts of reduction and oxidation. It can be explained in simple terms:

Oxidation describes the loss of electrons by a molecule, atom or ion.

Reduction describes the gain of electrons by a molecule, atom or ion. Though sufficient for many purposes, these descriptions are not precisely correct. Oxidation and reduction properly refer to a change in oxidation number—the actual transfer of electrons may never occur. Thus, oxidation is better defined as an increase in oxidation number, and reduction as a decrease in oxidation number. In practice, the transfer of electrons will always cause a change in oxidation number, but there are many reactions which are classed as "redox" even though no electron transfer occurs (such as those involving covalent bonds).

RESOURCE CONSERVATION AND RECOVERY ACT: The Resource Conservation and Recovery Act (RCRA), enacted in 1976, is a Federal law of the United States contained in 42 U.S.C. §§6901-6992k. It is usually pronounced as "rick-rah" or "Wreck-rah." RCRA is the United States' primary law governing the disposal of solid and hazardous waste. Congress passed RCRA on October 21, 1976 to address the increasing problems the nation faced from our growing volume of municipal and industrial waste. RCRA.

REVERSE OSMOSIS: Reverse osmosis (**RO**) is a separation process that uses pressure to force a solution through a membrane that retains the solute on one side and allows the pure solvent to pass to the other side. More formally, it is the process of forcing a solvent from a region of high solute concentration through a membrane to a region of low solute concentration by applying a pressure in excess of the osmotic pressure. This is the reverse of the normal osmosis process, which is the natural movement of solvent from an area of low solute concentration, through a membrane, to an area of high solute concentration when no external pressure is applied. The membrane here is semipermeable, meaning it allows the passage of solvent but not of solute. This phenomenon is commonly noticed in case of the water falling from the leaves of a tree.

SCADA: A remote method of monitoring pumps and equipment. 130 degrees F is the maximum temperature that transmitting equipment is able to withstand. If the level controller may be set too close a tolerance 45 could be the cause of a control system that is frequently turning a pump on and off.

SURFACTANT: The charge-balancing cations present on the raw zeolite surface (typically Na⁺, K⁺, Ca²⁺, and Mg²⁺) can be replaced by high-molecular-weight quaternary amines such as hexadecyltrimethylammonium (**HDTMA**). These quaternary amines (also known as cationic surfactants) exchange quantitatively and essentially irreversibly with cations on the external surface of the zeolite. The quaternary amines are too large to enter the internal pore structure of the zeolite, and the internal or zeolitic exchange sites potentially remain available to sorb smaller inorganic cations.

TRANSIENT, NON-COMMUNITY WATER SYSTEM: TNCWS A water system which provides water in a place such as a gas station or campground where people do not remain for long periods of time. These systems do not have to test or treat their water for contaminants which pose long-term health risks because fewer than 25 people drink the water over a long period. They still must test their water for microbes and several chemicals. A Transient Non-community Water System: Is not required to sample for VOC's.

U.S. ENVIRONMENTAL PROTECTION AGENCY: In the United States, this agency responsible for setting drinking water standards and for ensuring their enforcement. This agency sets federal regulations which all state and local agencies must enforce.

VOLATILE ORGANIC COMPOUNDS (VOCs): Solvents used as degreasers or cleaning agents. Improper disposal of VOCs can lead to contamination of natural waters. VOCs tend to evaporate very easily. This characteristic gives VOCs very distinct chemical odors like gasoline, kerosene, lighter fluid, or dry cleaning fluid. Some VOCs are suspected cancer-causing agents. Volatile organic compounds (VOCs) are organic chemical compounds that have high enough vapor pressures under normal conditions to significantly vaporize and enter the atmosphere.

A wide range of carbon-based molecules, such as aldehydes, ketones, and other light hydrocarbons are VOCs. The term often is used in a legal or regulatory context and in such cases the precise definition is a matter of law. These definitions can be contradictory and may contain "loopholes"; e.g. exceptions, exemptions, and exclusions. The United States Environmental Protection Agency defines a VOC as any organic compound that participates in a photoreaction; others believe this definition is very broad and vague as organics that are not volatile in the sense that they vaporize under normal conditions can be considered volatile by this EPA definition. The term may refer both to well characterized organic compounds and to mixtures of variable composition.

WATERBORNE DISEASE: A disease, caused by a virus, bacterium, protozoan, or other microorganism, capable of being transmitted by water (e.g., typhoid fever, cholera, amoebic dysentery, gastroenteritis).

WHOLE EFFLUENT TOXICITY: The total toxic effect of an effluent measured directly with a toxicity test

ZEOLITES: They are naturally occurring aluminosilicates characterized by high surface areas and high cation exchange capacities. Zeolites have a unique three-dimensional cage-like structure which has led to their use as molecular sieves. Their cation exchange properties are exploited in many wastewater treatment processes to remove cations such as ammonium and heavy metals. Naturally occurring sedimentary zeolites are found in massive deposits in many areas of the world. Typically, the zeolite may be crushed and sized as desired, tuning its permeability for flow-through applications.



Operator's Lab

Common Disinfectant Information

Contaminant	MRDL ¹ (mg/L) ²	MRDL ¹ (mg/L) ²	Potential Health Effects from Ingestion of Water	Sources of Contaminant in Drinking Water
Chloramines (as Cl ₂)	MRDLG=4 ¹	MRDL=4.0 ¹	Eye/nose irritation; stomach discomfort, anemia	Water additive used to control microbes
Chlorine (as Cl ₂)	MRDLG=4 ¹	MRDL=4.0 ¹	Eye/nose irritation; stomach discomfort	Water additive used to control microbes
Chlorine dioxide (as ClO ₂)	MRDLG=0.8 ¹	MRDL=0.8 ¹	Anemia; infants & young children: nervous system effects	Water additive used to control microbes

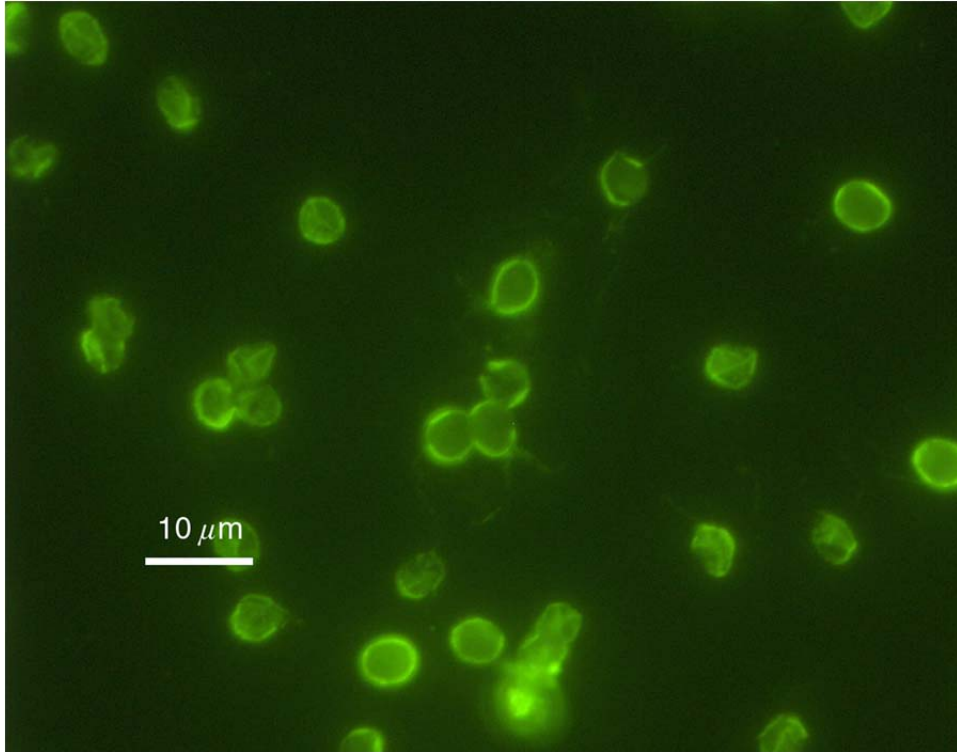

Above, Cryptosporidium

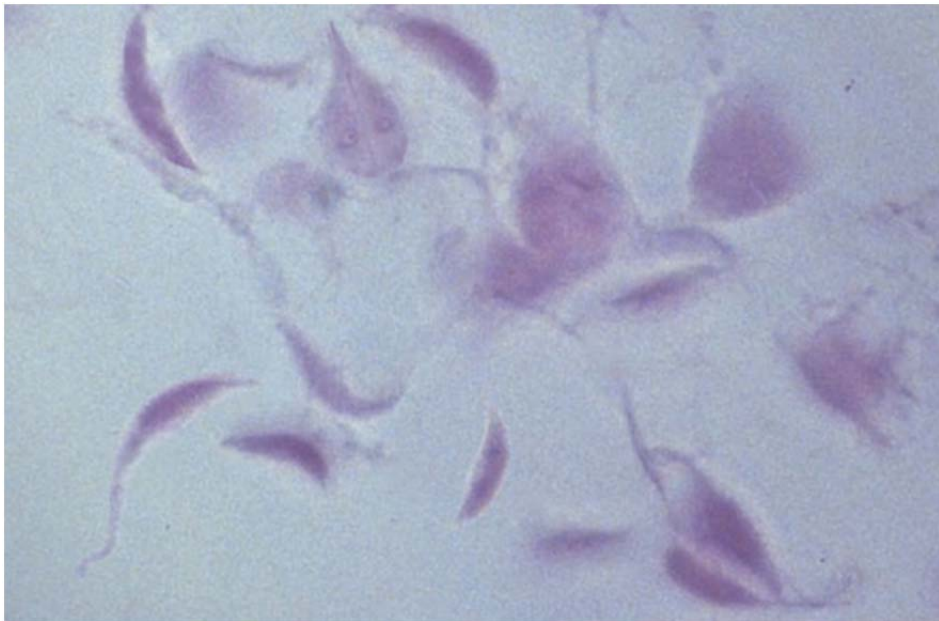

Giardia, bad news, most likely will be the customer's fault and not the water providers. My bet there is a baby in the customer's complaint.

Water Quality Section Chapter 5

What's that Stuff in the Tap Water?

by Jameel Rahman and Gary A. Burlingame

Jameel Rahman is a retired analytical chemist supervisor for the Materials Testing Laboratory at the Philadelphia Water Department, where Gary A. Burlingame is the supervisor of water quality and research. Contact Burlingame at gary.burlingame@phila.gov or (215) 685-1417.

Reprinted from Opflow, Vol. 29, No. 2 (February 2003), by permission. Copyright 2003, American Water Works Association.

Almost every water utility employee responsible for solving customer problems has fielded a complaint about particles in a bathtub or faucet aerator. Although particles can come from cold or hot water systems, household plumbing, water distribution systems, and water treatment, the water supplier—at least in customers' eyes—is usually “*guilty until proven innocent.*”

The Philadelphia Water Department has standardized procedures in place that can identify offending materials and help pinpoint their source.

Collecting and Identifying Particulates

Typically, the suspended matter customers complain about is particulate in form. The most important step in solving a particulate complaint is to collect as much suspect material as possible, making sure it represents the customer's actual concern. Sometimes enough material for analysis can be collected from faucet aerators. A container may be left with the customer for sample collection during normal tap use. Particulates can also accumulate in the toilet tank.

Particulate matter can be extracted from water samples by using nitrocellulose membrane filters. A 0.45 μm filter can be used if the water's colloidal matter doesn't clog the filter before enough particulate material is collected for analysis. Enough particulate matter can usually be captured with a water sample of approximately 250 mL. When samples have low turbidity, larger volumes will need to be filtered.

Granular Rust →

Under a microscope, examine the particulate matter captured on a filter. Use a zoom microscope with at least 40 \times , preferably 75 \times , magnification to identify matter on the membrane filter disk, which can be stored in a Plexiglas Petri dish. For optimum observation, illuminate the particulates from above with a fiber-optic light.



Some particulates can be identified by their appearance and, sometimes, by touching them with a sharp needle and observing their physical properties, such as softness, stickiness, or solubility in a solvent. Particulates can be quantified as few, several, or numerous. If particulates cannot be identified by their appearance, perform simple chemical tests on the filter.

A characteristic evolution of a gas, such as carbon dioxide from scale particulates or marble, can be observed under the microscope. Color formed by chemical reactions can be seen by the unaided eye. If these tests still fail to identify the debris, or further delineation is required, use infrared spectroscopy (**IR**).

Visual Identification

Sand particulates have a characteristic vitreous appearance and irregular shape with smooth facets. They can be colorful but usually appear translucent to whitish.

Mica particulates have a characteristic platelet shape and shine under reflected light. You will need to understand the common soil minerals in your area to identify them.

Man-made fibers, found in all colors and with a characteristic wrinkled strip shape, are present in single strands, have significant length, and often are visible to the unaided eye. Usually, fibers are not present in large numbers — at most, 10 per filter. Fibers used in apparel are round, but fibers found in water typically have a strip shape, indicating a common source, such as pump packing.

Glass chips are transparent, may have smooth facets with sharp edges, and may be colorful. Relatively large amounts of similar particulates often indicate a problem within a plumbing system. Usually the source of such particulates is disintegrating plastic, a rubber gasket, or a corroding component of the plumbing system.

Heat Identification

Activated carbon particulates are black and usually coated with debris. They can show porosity, but appear dull compared to anthracite particulates, which display a shiny luster under reflected light. Pick up a few particulates on the tip of a wetted platinum wire and burn them in the blue part of a Bunsen burner flame. AC particulates will burn instantaneously with a glitter and no visible smoke or residue.

Disintegrated plastic particulates are usually white, large, and may be present in large numbers. Pick up a few particulates and burn them in a Bunsen burner flame. Plastic burns with a smoke. With fine-tipped tweezers, remove sufficient particulates from the disk and further identify them by IR. Most often they are polypropylene plastic. Disintegrated rubber gasket particulates are usually black, relatively large, and do not smear the filter disk with black when a drop of toluene is applied. If pressed with a needle, they flex. Remove a few particulates and burn them; rubber burns with a black smoke. Identify them further by IR. Often these particulates are ethylene-propylene-diene monomer, used in gaskets.

Acid Identification

Rust particulates are usually abundant and are easy to identify with their typically brown and rough irregular shapes. Large particulates may have yellow and black streaks or inclusions, while fine rust particulates form a uniform brown film on the filter disk. To confirm rust, add a drop of (1+1) hydrochloric acid (500 mL of 11.5N hydrochloric acid [**HCl**] solution plus 500 mL of distilled water) to the filter. Yellow staining indicates the presence of ferric chloride.

Add a drop of 2 percent solution of potassium thiocyanate on the yellow area where HCl was added. Brick-red staining confirms the presence of potassium ferrithiocyanate.



Large Rust Particles

Lead solder particulates are gray and may have a whitish coating, are usually brittle, and can be easily pulverized. Often, they are relatively large in size compared to most other particulates on the filter disk. If lead particulates are suspected, add a drop of pH 2.8 tartrate-buffer solution followed by a drop of 0.2 percent solution of freshly prepared sodium rhodizonate. If the particulates turn scarlet red, lead solder is present.

Prepare a pH 2.8 buffer solution by dissolving 1.9 g of sodium bitartrate and 1.5 g of tartaric acid in 100 mL of distilled water. To prepare the sodium rhodizonate reagent, dissolve 0.2 g of rhodizonic acid disodium salt in 100 mL of distilled water.

Patina is hydrated basic copper carbonate and has a greenish color. These irregularly shaped particulates result from corrosion of copper and copper alloys. To confirm their presence, add a drop of (1+1) HCl from a Pasteur pipette. If tiny bubbles of carbon dioxide form under the microscope, the presence of patina is indicated. Remove a few particulates and place them in the cavity of a spot-test plate. Add a drop of (1+1) HCl followed by a drop of ammonia. Appearance of a blue precipitate or blue color confirms the presence of patina particulates. Rust particulates will interfere with this test if it is performed on the rust-coated filter. Calcium carbonate can develop as a white scale through evaporation of hard water or can occur as a particulate of limestone or calcite. Scales can form in water heaters.

Limestone can come from water treatment processes. Add a drop of HCl (1+1) on the particulates and observe the evolution of carbon dioxide under the microscope. The brisk evolution of gas confirms the presence of carbonates.

Solvent Identification

Asphalt pipe-coating compounds are black. To differentiate between various black particulates, add a drop of toluene or chloroform to the filter disk under the microscope. If the disk becomes smeared with black around the particulates, the particulates are classified as pipe-coating of an asphaltic nature. Anthracite, activated carbon, and rubber particulates are insoluble in the solvents used.

Anthracite particulates appear shiny compared with other black particulates and do not smear the filter disk if a drop of toluene is applied. These particulates can be removed from the filter disk and burned in a crucible; they will leave a solid residue.

Grease particulates are black and may be shiny. They are usually present as tiny heaps on the filter disk because of their softness and hydrophobic nature. They are soft and sticky when touched with a needle and can be smeared easily on the disk. Add a drop of toluene; grease will dissolve and a black color will spread around the particulates.

Let the toluene evaporate or use an oven to expedite drying. Touch the particulates with a needle in the area where toluene was added; they should no longer be sticky and may behave like a black powder. All greases may not behave this way, but their stickiness and extreme softness differentiates them from other black particulates.

Infrared Spectroscopy

When particulates cannot be completely identified by the above means, use IR to identify organic and inorganic materials. Inorganic compounds include calcium carbonate, calcium sulfate, barium sulfate, lead carbonate, metal oxides, silicates, or phosphates. Visually, and with the aid of heat, you might suspect a particulate is plastic in nature, but various types of plastics can occur in water systems, including polypropylene, polyvinyl chloride, and polyethylene. IR can differentiate between plastic materials.

Atoms in a molecule are in constant motion, changing bond angles by bending and bond lengths by stretching. Among these motions only certain vibrations absorb infrared radiation of specific energy. When portions of electromagnetic radiation are absorbed by such vibrations, an IR absorption band spectrum appears, which an infrared spectrometer records. Each compound has a unique infrared absorption spectrum, and various compounds can be identified by comparing absorption band positions in the IR spectrum of an unknown compound to band positions of known compounds.

Particulates are removed with fine-tipped tweezers one by one from the filter disk and transferred to a small vial for dissolving in a solvent, or to a small agate mortar for grinding and mixing with KBr for making a potassium bromide (KBr) pellet. The usually brittle plastic fragments can be powdered easily, and 10 mg of sample is all that is commonly needed to produce a good infrared absorption spectrum. Inorganic materials are identified by IR scanning of the KBr pellet of the sample alone; organic materials are identified by scanning a pellet or a film of the sample cast on a KBr plate.



Zeolite particles from a household water softener.

Most plastics are readily soluble in hot o-dichlorobenzene; try dissolving the sample in this solvent first. If soluble, cast a film of the sample on a KBr plate and scan it. If the sample is insoluble, evaporate the solvent completely and transfer the particulates to an agate mortar, make a KBr pellet, and scan the pellet. After obtaining a reasonably strong infrared spectrogram, the sample is identified by manual means or a computer search of a commercially available online IR library.

Standard Chemical Analyses

Chemical analyses available in most full-service water testing laboratories can be used to identify particulates when sufficient material is available. For example, hydrated aluminum oxide can occur as white slurry and be analyzed by inductively coupled plasma emission spectrometry after dissolving in mineral acids.

Similarly, granules of lead solder can also be analyzed by wet chemical or instrumental methods. After a sample is dissolved in a mineral acid, it can be analyzed for various elements by atomic absorption spectrophotometry. A variety of materials, including iron oxides, manganese dioxides, aluminum oxides, calcium carbonates, and copper and silicate particulates, can be identified by common chemical analyses.

During the late 1990s, customers in Philadelphia and across the country complained about white particulates clogging faucet aerators. Infrared spectroscopy revealed the particulates to be polypropylene, a plastic not used in the distribution system. The only common source for this plastic was found to be the dip tubes in residential gas hot-water heaters (see Opflow, December 1998).

Eventually, the dip-tube manufacturer admitted to changing materials to a less-durable plastic, prompting water heater manufacturers to give rebates to customers for dip-tube replacements. When this issue made the TV news, Philadelphia was in a good position to explain the situation to customers because our procedure was already in place for testing and characterizing particulates.



Dip Tube Particles

Table 1. Potential sources for particulate matter found in tap water

	From Customer Plumbing	From Water Supplier Piping
Particulate		
Activated carbon fines		X
Asphaltic lining fragments		X
Backfill sand		X
Calcium carbonate scale	X	X
Cast iron rust		X
Cement lining fragments		X
Copper fragments	X	
Glass chips		X
Greases and lubricants	X	X
Lead fragments	X	
Manganese dioxide deposits		X
Man-made fibers		X
On-site treatment device media		X
Plastic fragments	X	
Rubber gasket fragments	X	X
Soil minerals, mica		X

Table 2. Suspended matter classified by size

Soluble	< 0.45 µm
Colloidal	< 1.0 µm but > 0.45 µm
Particulate	> 1.0 µm

End of Article *by Jameel Rahman and Gary A. Burlingame*

Types of Algae

The simplest algae are single cells (e.g., the **diatoms**); the more complex forms consist of many cells grouped in a spherical colony (e.g., *Volvox*), in a ribbon like filament (e.g., *Spirogyra*), or in a branching thallus form (e.g., *Fucus*).

The cells of the colonies are generally similar, but some are differentiated for reproduction and for other functions.

Kelps, the largest algae, may attain a length of more than 200 ft (61 m). *Euglena* and similar genera are free-swimming one-celled forms that contain chlorophyll but that are also able, under certain conditions, to ingest food in an animal like manner.

The green algae include most of the freshwater forms. The **pond scum**, a green slime found in stagnant water, is a green alga, as is the green film found on the bark of trees. The more complex brown algae and red algae are chiefly saltwater forms; the green color of the chlorophyll is masked by the presence of other pigments. Blue-green algae have been grouped with other prokaryotes in the kingdom **Monera** and renamed **cyanobacteria**.

Pond scum, is an accumulation of floating green **algae** on the surface of stagnant or slowly moving waters, such as ponds and reservoirs. One of the most common forms is *Spirogyra*.

With the exception of the larger Algae -- seaweeds and kelp -- Protocista are pretty much all microscopic organisms.

Green Algae (*Gamophyta & Chlorophyta*)

7000 species

Red Algae (*Rhodophyta*)

4000 species such as this Coralline Alga (*Calliarthron tuberculatum*)

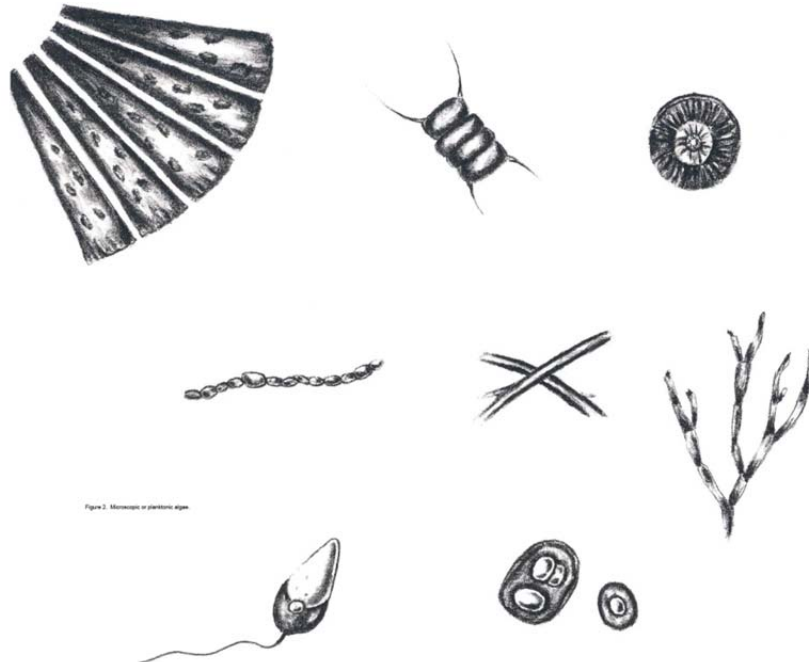

Other species include Diatoms (Bacillariophyta, 10,000 species) and various Plankton

Major Algae Groups



Blue-green algae are the slimy stuff. Its cells lack nuclei and its pigment is scattered. Blue-green algae are not actually algae, they are bacteria.

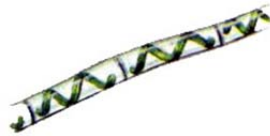

Green algae cells have nuclei and the pigment is distinct. Green algae are the most common algae in ponds and can be multicellular.



Euglenoids are green or brown and swim with their flagellum, too. They are easy to spot because of their red eye. Euglenoids are microscopic and single celled.



Dinoflagellates have a flagella and can swim in open waters. They are microscopic and single celled.



Diatoms look like two shells that fit together. They are microscopic and single celled.

Jar Test Section

Jar testing, to determine the proper coagulant dosage, continues to be one of the most effective tools available to surface water plant operators. Finished water quality, cost of production, length of filter runs, and overall filter life all depend on the proper application of chemicals to the raw water entering the treatment plant.

BEFORE YOU START

The jar test, as with any coagulant test, will only provide accurate results when properly performed. Because the jar test is intended to simulate conditions in your plant, developing the proper procedure is very important. Take time to observe what happens to the raw water in your plant after the chemicals have been added, then simulate this during the jar test. **THE RPM OF THE STIRRER AND THE MINUTES TO COMPLETE THE TEST DEPEND ON CONDITIONS IN YOUR PLANT.** If, for instance, your plant does not have a static or flash mixer, starting the test at high rpm would provide misleading results. This rule applies to flocculator speed, length of settling time and floc development. Again, operate the jar test to simulate conditions in **YOUR** plant.

1. SCOPE

1.1 This practice covers a general procedure for the evaluation of a treatment to reduce dissolved, suspended, colloidal, and non-settleable matter from water by chemical coagulation-flocculation, followed by gravity settling. The procedure may be used to evaluate color, turbidity, and hardness reduction.

1.2 The practice provides a systematic evaluation of the variables normally encountered in the coagulation-flocculation process.

1.3 This standard does not purport to address the safety concerns, if any, associated with its use. It is the responsibility of the user of this standard to establish appropriate safety and health practices and determine the applicability of regulatory limitations prior to use.



Terms Great information for your assignment

Flocculation - Agglomeration of particles into groups, thereby increasing the effective diameter.

Coagulation - A chemical technique directed toward destabilization of colloidal particles.

Turbidity - A measure of the presence of suspended solid material.

Colloidal - A suspension of small particles; a suspension of small particles dispersed in another substance.

Turbidity

Particles less than or about 1 to 10 μm in diameter (primarily colloidal particles) will not settle out by gravitational forces, therefore making them very difficult to remove. These particles are the primary contributors to the turbidity of the raw water causing it to be “cloudy”. The most important factor(s) contributing to the stability of colloidal particles is not their mass, but their surface properties.

This idea can be better understood by relating the colloidal particles’ large surface area to their small volume (**S/V**) ratio resulting from their very small size. In order to remove these small particles we must either filter the water or somehow incorporate gravitational forces such that these particles will *settle* out. In order to have gravity affect these particles, we must somehow make them larger, somehow have them come together (agglomerate); in other words, somehow make them “stick” together, thereby increasing their size and mass.

The two primary forces that control whether or not colloidal particles will agglomerate are:

Repulsive force

$$\zeta = \frac{4 \pi q d}{D}$$

An electrostatic force called the “Zeta Potential” -

Where:

ζ = Zeta Potential

q = charge per unit area of the particle

d = thickness of the layer surrounding the shear surface through which the charge is effective

D = dielectric constant of the liquid

Attractive force

Force due to van der Waals forces

Van der Waals forces are weak forces based on a polar characteristic induced by neighboring molecules.

When two or more nonpolar molecules, such as He, Ar, H₂, are in close proximity, the nucleus of each atom will weakly attract electrons in the counter atom resulting, at least momentarily, in an asymmetrical arrangement of the nucleus.

This force, van der Waals force, is inversely proportional to the sixth power of the distance ($1/d^6$) between the particles.

As can clearly be seen from this relationship, decay of this force occurs exponentially with distance.

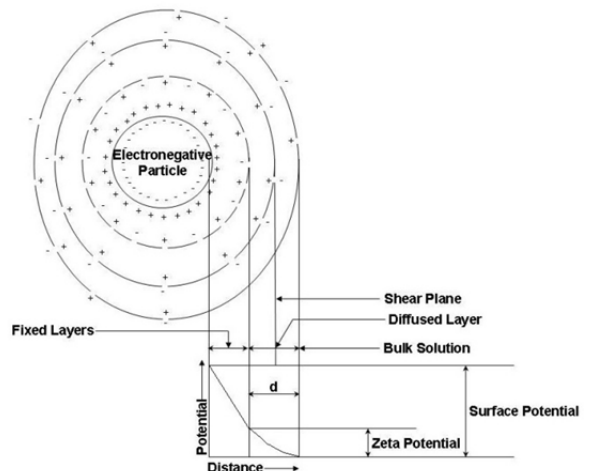

Ways to Measure Turbidity

- 1.) Jackson Candle Test
- 2.) Secchi Disk - a black and white disk divided like a pie in 4 quadrants about 6" in diameter.
- 3.) Turbidimeter - Light is passed through a sample. A sensitive photomultiplier tube at a 90° angle from the incident light beam detects the light scattered by the particles in the sample. The photomultiplier tube converts the light energy into an electrical signal, which is amplified and displayed on the instrument.
 - a.) *Units* - Nephelometric Turbidity Unit (**NTU**) or Formazin Turbidity Unit (**FTU**).

How to Treat Turbidity

Supercharge the water supply - By supercharging the water supply momentarily with a positive charge, we can upset the charge effect of the particle enough to reduce the Zeta potential (repulsive force), thereby allowing van der Waals forces (attractive forces) to take over.

By introducing aluminum (Al_3^+) into the water in the form of Alum ($\text{Al}_2(\text{SO}_4)_3 \cdot n\text{H}_2\text{O}$) we can accomplish the supercharging of the water. This is the **coagulation** part of the coagulation/flocculation process; flocculation follows coagulation. During the **flocculation** process the particles join together to form flocs; the larger the flocs, the faster they will settle within a clarifier.

Other chemical coagulants used are Ferric Chloride and Ferrous Sulfate. Alum works best in the pH range of natural waters, 5.0 - 7.5. Ferric Chloride works best at lower pH values, down to pH 4.5. Ferrous Sulfate works well through a range of pH values, 4.5 to 9.5.

During the coagulation process, charged hydroxy-metallic complexes are formed momentarily (i.e. $\text{Al}(\text{OH})_2^+$, $\text{Al}(\text{OH})_2^{1+}$ etc). These complexes are charged highly positive, and therefore upset the stable negative charge of the target particles, thereby momentarily displacing the water layer surrounding the charged particle. This upset decreases the distance "d," in turn decreasing the Zeta potential.

The particles are then able to get close enough together for van der Waals forces to take over and the particles begin to flocculate. The chemical reaction continues until the aluminum ions (Al^3_3) reach their final form, $\text{Al}(\text{OH})_3$ (s), and settle out (note – the flocculated particles settle out separately from the precipitated $\text{Al}(\text{OH})_3$ (s)).

If too much alum is added, then the opposite effect occurs--the particles form sub complexes with the Al^3_3 and gain a positive charge about them, and the particles re-stabilize.

The final key to obtaining good flocs is the added energy put into the system by way of rotating paddles in the flocculator tanks. By "**pushing**" (adding energy) the particles together we can aid in the flocculation process, forming larger flocs.

It is important to understand that too much energy, i.e. rotating the paddles too fast, would cause the particles to shear (breakup), thereby reducing the size of the particles and increasing the settling time in the clarifier.

Key Equations

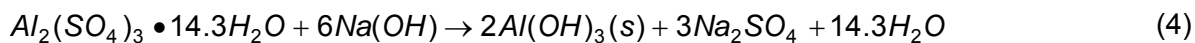
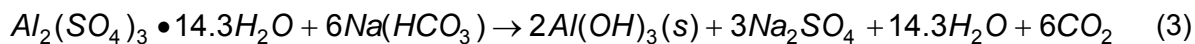
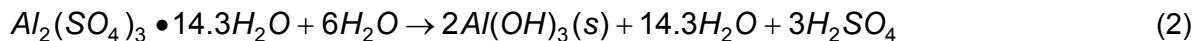

Apparatus

- Jar Test Apparatus
- 6 1500 mL Beakers
- pH meter
- Pipettes
- Conductivity Meter
- Turbidimeter

Procedure

- Make up a 10-g/L solution of alum.
- Make up a 0.1 N solution of NaOH (buffer). ($\text{Na}^{+1} = 23 \text{ mg/mmol}$, $\text{O}^{-2} = 16 \text{ mg/mmol}$, $\text{H}^{+} = 1 \text{ mg/mmol}$)
- Fill each of the six 1500 mL beakers with one-liter of river water.
- Measure the temperature and conductivity.
- Measure the initial pH
- Add alum and NaOH solutions in equal portions as specified by instructor.
- Mixing protocol:
 - rapid mix - 1 minute (100 rpm)
 - slow mix - 15 minutes (20 rpm)
 - off, settling - 30 minutes
- Measure final turbidity. Take the sample from the center, about 2" down for each one liter sample. Be careful not to disturb the flocs that have settled.
- Measure final pH



Preparing Polymers for the Jar Test

A successful Jar Test is very reliant upon the proper preparation of the polymers being tested. Dilution technique ("**make down**") is especially critical, since it involves compactly coiled large molecules in emulsions, prior to activation. The polymer must be uncoiled to provide maximum contact with the colloidal particles to be flocculated. If the following procedures are not followed, the Jar Test results will be very unreliable.

Required Equipment:

- 250 mL bottles with lids.
- High speed hand mixer (for emulsion polymers).
- Syringes (1cc, 5cc, 10cc).
- 250 and 500 mL beakers.
- Water (it is recommended that the make-down water from the plant be used).
- Graduated cylinder (100 mL).

Emulsion Polymers (Prepare 1.0% solution.)

- Add 198 mL of water to a beaker.
- Insert Braun mixer into water and begin mixing.
- Using a syringe, inject 2 mL of neat polymer into vortex.
- Mix for 20 seconds. Do not exceed 20 seconds!
- Allow dilute polymer to age for at least 20 minutes, but preferably overnight. Prepare 0.1% solution.
- Add 180 mL of water to 250 mL bottle.
- Add 20 mL of 1.0% polymer solution.
- Shake vigorously for at least one minute.

Solution Polymers and Inorganics (Prepare a 1.0% solution.)

- Add 198 mL of water to 250 mL bottle.
- Using a syringe, add 2 mL of neat product to bottle.
- Shake vigorously for at least 1 minute.
- Prepare 0.1% solution.
- Add 180 mL to 250 mL bottle.
- Add 20 mL of 1 % solution.
- Shake vigorously for at least one minute.

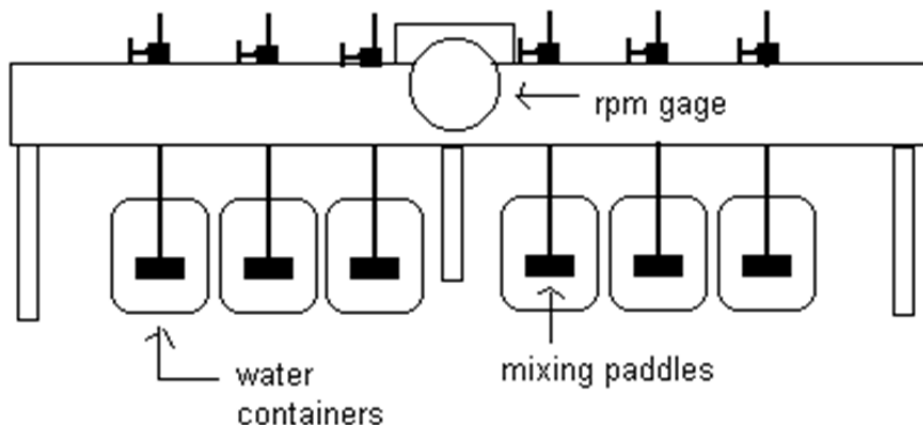

Potassium Permanganate Jar Test

Potassium Permanganate has been used for a number of years in both water and wastewater treatment. KMnO_4 is a strong oxidizer which can be used to destroy many organic compounds of both the natural and man-made origin. KMnO_4 is also used to oxidize iron, manganese and sulfide compounds and other taste and odor producing substances usually due to the presence of very small quantities of secretions given off by microscopic algae, which develop on the surface waters and on beds of lakes and rivers under certain conditions of temperature and chemical composition.

KMnO_4 must be used with caution, as this material produces an intense purple color when mixed with water. As the permanganate ion is reduced during its reaction with compounds that it oxidizes, it changes color from purple, to yellow or brown. The final product formed is manganese dioxide (MnO_2), an insoluble precipitate that can be removed by sedimentation and filtration.

All KMnO_4 applied must be converted to manganese dioxide (MnO_2) prior to filtration. If it is not all converted and is still purple or pink, it will pass through the filter into the clearwell or distribution system. This may cause the customer to find pink tap water, or the reaction may continue in the system and the same conditions as exist with naturally occurring manganese may cause staining of the plumbing fixtures.

Stock Solutions

(Strong Stock Solution)

5 grams potassium permanganate dissolved in 500 ml distilled water.

(Test Stock Solution)

4 ml strong stock solution thoroughly mixed in 100 ml distilled water.

Each 5 ml of the test stock solution added to a 2000 ml sample equals 1 mg/l.



Jar Testing Example

If you have a six position stirrer:

Using a graduated cylinder, measure 2000 ml of the sample to be tested into each of the six beakers. Dose each beaker to simulate plant practices in pre-treatment, pH adjustment, coagulant,- etc. Do not add carbon or chlorine. Using a graduated pipette, dose each beaker with the test stock solution in the following manner.

Jar #	KMnO_4	ml KMnO_4 mg/l	Color
1	0.50	0.10	no pink
2	0.75	0.15	no pink
3	1.00	0.20	no pink
4	1.25	0.25	no pink
5	1.50	0.30	pink
6	1.75	0.35	pink

Stir the beakers to simulate the turbulence where the KMnO_4 is to be added and observe the color change.

As the iron and manganese begin to oxidize, the sample will turn varying shades of brown, indicating the presence of oxidized iron and or manganese. Samples which retain a brown or yellow color indicate that the oxidation process is incomplete and will require a higher dosage of KMnO_4 .

The end point has been reached when a pink color is observed and remains for at least 10 minutes. In the preceding table a pink color first developed in beaker #5 which had been dosed with 1.5 ml/ 0.3 mg/l. If the first jar test does not produce the correct color change, continue with increased dosages.

When applying potassium permanganate to raw water, care must be taken not to bring pink water to the filter unless you have "**greensand**". Also, permanganate generally reacts more quickly at pH levels above 7.0.

Quick Test

A quick way to check the success of a KMnO_4 application is by adding 1.25 ml of the test stock solution to 1000 ml finished water. If the sample turns brown there is iron or manganese remaining in the finished water. If the sample remains pink, oxidation is complete.

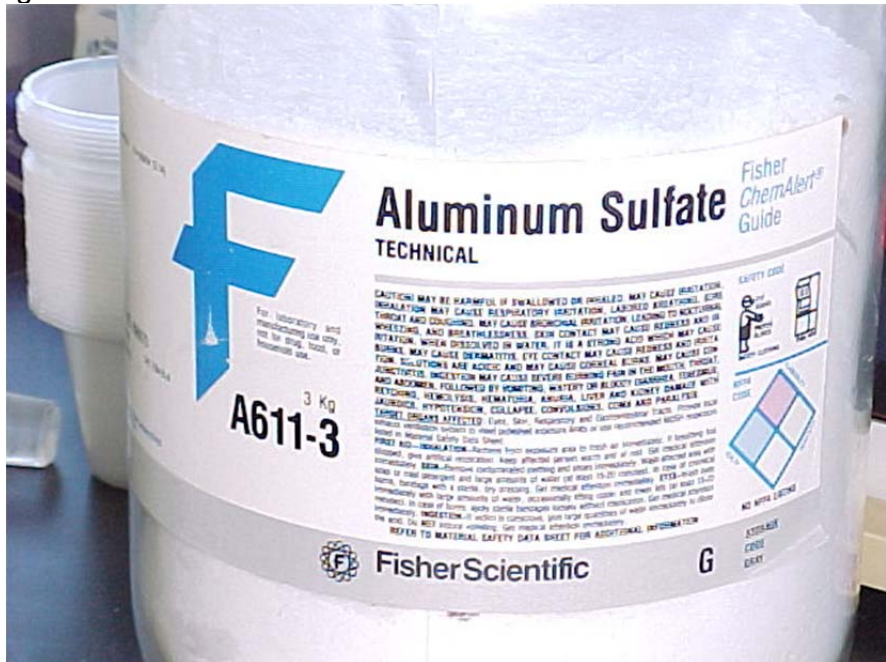

With proper application, potassium permanganate is an extremely useful chemical treatment.

As well as being a strong oxidizer for iron and manganese, KMnO_4 used as a disinfectant in pre-treatment could help control the formation of trihalomethanes by allowing chlorine to be added later in the treatment process or after filtration. Its usefulness also extends to algae control, as well as many taste/odor problems.

To calculate the dosage of KMnO_4 for iron and manganese removal, here is the formula to use.

$$\text{KMnO}_4 \text{ Dose, mg/l} = 0.6(\text{iron, mg/l}) + 2.0(\text{Manganese, mg/l})$$

Example:

Calculate the KMnO_4 dose in mg/l for a water with 0.4 of iron. The manganese concentration is 1.2 mg/l.

Known Unknown

Iron, mg/l = 0.4 mg/l KMnO_4 Dose, mg/l

Manganese, mg/l = 1.2 mg/l

Calculate the KMnO_4 dose in mg/l.

$$\begin{aligned}\text{KMnO}_4 \text{ Dose, mg/l} &= 0.6(\text{Iron, mg/l}) + 2.0(\text{Manganese, mg/l}) \\ &= 0.6(0.4 \text{ mg/l}) + 2.0(1.2 \text{ mg/l}) \\ &= 2.64 \text{ mg/l}\end{aligned}$$

Note: The calculated 2.64 mg/l KMnO_4 dose is the minimum dose. This dose assumes there are no oxidizable compounds in the raw water. Therefore, the actual dose may be higher. Jar testing should be done to determine the required dose.

Alkalinity

Introduction

Alkalinity of water is its acid-neutralizing capacity. It is the sum of all the titratable bases. The measured value may vary significantly with the end-point pH used. Alkalinity is a measure of an aggregate property of water and can be interpreted in terms of specific substances only when the chemical composition of the sample is known.

Alkalinity is significant in many uses and treatments of natural waters and wastewaters. Because the alkalinity of many surface waters is primarily a function of carbonate, bicarbonate, and hydroxide content, it is taken as an indication of the concentration of these constituents. The measured values also may include contributions from borates, phosphates, silicates or other bases if these are present. Alkalinity in excess of alkaline earth metal concentrations is significant in determining the suitability of water for irrigation. Alkalinity measurements are used in the interpretation and control of water and wastewater treatment processes.

Titration Method

a. Principle

Hydroxyl ions present in a sample, as a result of dissociation or hydrolysis of solutes react with additions of standard acid. Alkalinity thus depends on the end-point pH used.

b. Reagents

- i) Standard Hydrochloric Acid – 0.02 N.
- ii) Methyl Orange Indicator – Dissolve 0.1 g of methyl orange in distilled water and dilute to 1 liter.
- iii) Sodium carbonate solution, 0.02 N : Dry 3 to 5 g primary standard Na_2CO_3 at 250°C for 4 h and cool in a desiccator. Weigh 1.03 gm. (to the nearest mg), transfer to a 1-L volumetric flask, fill flask to the mark with distilled water, dissolve and mix reagent. Do not keep longer than 1 week.

c. Procedure

Titrate over a white surface 100 ml of the sample contained in a 250-ml conical flask with standard hydrochloric acid using two or three drops of methyl orange Indicator. (**NOTE** – If more than 30 ml of acid is required for the titration, a smaller suitable aliquot of the sample shall be taken.)

d. Calculation

Total alkalinity (as CaCO_3), mg/l = 10 V or $N \times V \times 50 \times 1000$

T.A. (as CaCO₃) = -----

Sample Amount

Where N = Normality of HCl used

V = volume in ml of standard hydrochloric acid used in the titration.

Alkalinity to Phenolphthalein

The sample is titrated against standard acid using phenolphthalein indicator.

a. Reagents

i) Phenolphthalein Indicator Solution :

Dissolve 0.1 g of phenolphthalein in 60 ml of ETHANOL and dilute with Distilled water to 100 ml.

ii) Standard hydrochloric Acid – 0.02 N.

b. Procedure

Add 2 drops of phenolphthalein indicator solution to a sample of suitable size, 50 or 100 ml, in a conical flask and titrate over a white surface with standard hydrochloric acid.

c. Calculation

$$\text{Alkalinity to phenolphthalein (as CaCO}_3\text{), mg/l} = \frac{1000 V_1}{V_2}$$

Where

V₁ = volume in ml of standard hydrochloric acid used in the titration , and

V₂ = Volume in ml of the sample taken for the test.

Caustic Alkalinity

a. General

Caustic alkalinity is the alkalinity corresponding to the hydroxides present in water and is calculated from total alkalinity (T) and alkalinity to phenolphthalein (P).

b. Procedure

Determine total alkalinity and alkalinity to phenolphthalein and calculate caustic alkalinity as shown in Table below.

Result of Titration Caustic Alkalinity or Hydroxide Alkalinity as CaCO₃
Carbonate Alkalinity as CaCO₃
Bicarbonate Concentration as CaCO₃

Result of Titration

	Caustic Alkalinity or Hydroxide Alkalinity as CaCO ₃	Carbonate Alkalinity as CaCO ₃	Bicarbonate Concentration as CaCO ₃
P=0	0	0	0
P<1/2T	0	2P	T-2P
P=1/2T	0	2P	0
P>1/2T	2P-T	2(T-P)	0
P=T	T	0	0

The alkalinity of water is a measure of its capacity to neutralize acids. The alkalinity of natural water is due to the salts of carbonate, bicarbonate, borates, silicates and phosphates along with the hydroxyl ions in free state. However, the major portion of the alkalinity in natural waters is caused by hydroxide, carbonate, and bicarbonates which may be ranked in order of their association with high pH values. Alkalinity values provide guidance in applying proper doses of chemicals in water and waste water treatment processes, particularly in coagulation and softening.

Alkalinity (total)

References: ASTM D 1067-92, Acidity or Alkalinity of Water.

APHA Standard Methods, 19th ed., p. 2-26, method 2320B (1995).

EPA Methods for Chemical Analysis of Water and Wastes, method 310.1 (1983).

The alkalinity of water is a measurement of its buffering capacity or ability to react with strong acids to a designated pH. Alkalinity of natural waters is typically a combination of bicarbonate, carbonate, and hydroxide ions. Sewage and wastewaters usually exhibit higher alkalinities either due to the presence of silicates and phosphates or to a concentration of the ions from natural waters.

Alkalinity inhibits corrosion in boiler and cooling waters and is therefore a desired quality which must be maintained. It is also measured as a means of controlling water and wastewater treatment processes or the quality of various process waters. In natural waters, excessive alkalinity can render water unsuitable for irrigation purposes and may indicate the presence of industrial effluents. *The Titrimetric Method*. CHEMetrics' tests determine total or "M" alkalinity using an acid titrant and a pH indicator. The end point of the titration occurs at pH 4.5. Results are expressed as ppm (mg/L) CaCO₃.

Hardness (calcium)

Reference: West, T. S., DSC, Ph.D., Complexometry with EDTA and Related Reagents, 3rd ed., p. 46, 164 (1969).

Originally described as water's capacity to precipitate soap, hardness is one of the most frequently determined qualities of water. It is a composite of the calcium, magnesium, strontium, and barium concentrations in a sample. The current practice is to assume total hardness refers to the calcium and magnesium concentrations only.

Completely de-hardened water, resulting from sodium zeolite or other suitable ion exchange treatment, is required for various processes-including power generation, printing and photo finishing, pulp and paper manufacturing, and food and beverage processing. Hard water can cause scale formation on heat exchange surfaces, resulting in decreased heat transfer and equipment damage.

The Titrimetric Method. This method is specific for calcium hardness. The EGTA titrant in alkaline solution is employed with zincon indicator. Results are expressed as ppm (mg/L) CaCO₃.

Shelf-life. 8 months. Although the reagent itself is stable, the end point indicator has a limited shelf-life. We recommend stocking quantities that will be used within 7 months.

Hardness (total)

References: Colorimetric-Calcichrome chemistry--Method developed by CHEMetrics, Inc. Titrimetric--APHA Standard Methods, 19th ed., p. 2-36, method 2340 C (1995). EPA Methods for Chemical Analysis of Water and Wastes, method 130.1 (1983).

For a discussion of hardness, see Hardness (calcium).

The colorimetric method is applicable to monitoring boiler feedwater and other industrial waters. The titrimetric method is applicable to drinking, surface, and brine waters. *The Colorimetric Method*. CHEMetrics developed the sensitive Calcichrome reagent, which is a dark purple color. It reacts to form a light purple color at the lower end of the range, and forms a light blue color at the end of the range. Results are expressed as ppm (mg/L) or ppb ($\mu\text{g/L}$) CaCO_3 . *The Titrimetric Method*. The EDTA titrant is employed in alkaline solution with a calmagite indicator. This method determines the combined calcium and magnesium concentration of a sample. If no magnesium is present, the end point of the titration normally appears sluggish. However, the reagent has been specially formulated to ensure a sharp end point, regardless of the presence of magnesium. Results are expressed as ppm (mg/L) CaCO_3 .

Iron (total)

Reference: J. A. Tetlow and A. L. Wilson, "Determination of Iron in Boiler Feedwater", Analyst, 1958. See discussion under Iron (total & soluble). CHEMetrics' colorimetric method for determining total iron uses thioglycolic acid to dissolve particulate iron and to reduce any iron from the ferric to the ferrous state. Ferrous iron then reacts with PDTs in acid solution to form a purple-colored chelate. Results are expressed as ppm (mg/L) Fe.

Manganese

Reference: APHA Standard Methods, 14th ed., p. 227, method 314C (1975).

Surface and ground waters rarely contain more than 1 mg/L of soluble or suspended manganese. Manganese can act as an oxidizing or reducing agent, depending on its valence state. In various forms, it is used as a pigment or a bleaching agent. Manganese concentrations in potable water should not exceed 0.05 mg/L. Concentrations greater than 0.1 mg/L will impart a foul taste to water and discolor laundry and porcelain surfaces. Levels higher than 1 mg/l in surface waters can result from mining operations or excessive discharging from domestic waste treatment facilities or industrial plants.

The Colorimetric Method

CHEMetrics' tests measure soluble manganese compounds but do not differentiate the various valence states. Manganese is oxidized in the presence of periodate to form a deep-red reaction product. Reducing agents will interfere. Results are expressed as ppm (mg/L) Mn.

Fluorides

Fluoride ions have dual significance in water supplies. High concentration of F- causes dental fluorosis (disfigurement of the teeth). At the same time, a concentration less than 0.8 mg/l results in 'dental caries'. Hence it is essential to maintain the F- conc. between 0.8 to 1.0 mg/L in drinking water. Among the many methods suggested for the determination of fluoride ion in water, the colorimetric method (SPADNS) & the ion selective electrode method are the most satisfactory and applicable to variety of samples. Because all of the colorimetric methods are subject to errors due to the presence of interfering ions, it may be necessary to distill the sample before making the fluoride estimation, while addition of the

prescribed buffer frees the electrode method from the interference, caused by such relatively common ions as aluminum hexametaphosphate and orthophosphate which adversely affect the colorimetric methods. However, samples containing fluoroborate ion (BF_4), must be subject to a preliminary distillation step in either of the methods. Both the methods and the preliminary distillation step are discussed below.

1. SPADNS METHOD

Principle

Under acid condition fluorides (**HF**) react with zirconium SPADNS solution and the 'Lake' (color of SPADNS reagent) gets bleached due to formation of ZrF_6 . Since bleaching is a function of fluoride ions, it is directly proportional to the concentration of F. It obeys Beer's law in a reverse manner.

Interference

Alkalinity 5000 mg/L, aluminum 0.1 mg/L, chlorides 7000 mg/L, Fe 10 mg/L, PO_4 16 mg/L, SO_4 200 mg/L, and hexametaphosphate 1.0 mg/L interfere in the bleaching action. In presence of interfering radicals distillation of sample is recommended.

Apparatus

1. Distillation apparatus (as shown in the Fig. 3)
2. Colorimeter for use at 570 nm.
3. Nessler's tubes cap. 100 ml.

Reagents

1. Sulphuric acid H_2SO_4 concentration.
2. Silver Sulfate Ag_2SO_4 crystals.
3. SPADNS solution : Dissolve 958 mg SPADNS and dilute to 500 ml.
4. Zirconyl acid reagent : Dissolve 133 mg $\text{ZrOCl}_2 \cdot 8\text{H}_2\text{O}$ in 25 ml water. Add 350 ml conc. HCl and dilute to 500 ml.
5. Mix equal volume of 3 and 4 to produce a single reagent. Protect from direct light.
6. **Reference solution:** Add 10 ml SPADNS solution to 100 ml distilled water. Dilute 7 ml concentration HCl to 10 ml and add to diluted SPADNS solution.
7. **Sodium arsenite solution:** Dissolve 5.0 g NaAsO_2 and dilute to 1000 ml.
8. **Stock F- solution:** Dissolve 221.0 mg anhydrous NaF and dilute to 1000 ml. 1 ml = 100 mg F-.
9. **Standard F :** Dilute stock solution 10 times to obtain 1 ml = 10mg F.

A. Preliminary Distillation Step

Place 400 ml distilled water in the distilling flask and carefully add 200 ml conc. H_2SO_4 . Swirl until the flask contents are homogenous, add 25 to 30 glass beads and connect the apparatus as shown in Fig 1. Begin heating slowly at first and then rapidly until the temperature of the flask reaches exactly 180°C . Discard the distillate. This process removes fluoride contamination and adjusts the acid-water ratio for subsequent distillations. After cooling, the acid mixture remaining after above step or previous distillation to 120°C or below add 300 ml of sample, mix thoroughly, and distill as before until the temperature reaches 180°C . Do not heat above 180°C to prevent Sulfate carryover.

Add Ag_2SO_4 to distilling flask at the rate of 5 mg/mg Cl when high chloride samples are distilled. Use the sulphuric acid solution in the flask repeatedly until the contaminants from the samples accumulate to such an extent that recovery is affected or interferences appear in the distillate. After the distillation of high fluoride samples, flush the still with 300 ml distilled water and combine the two fluoride distillates. After periods of inactivity, similarly flush the still, discard the distillate.

B. Procedure

1. Prepare standard curve in the range 0.0 to 1.40 mg/L by diluting appropriate volume of standard F solution to 50 ml in Nessler's tubes.
2. Add 10.0 mL mixed reagent prepared as in 5 above to all the samples, mix well and read optical density of bleached color at 570 nm using reference solution for setting zero absorbance.
3. Plot conc. Vs. % transmission or absorbance.
4. If sample contains residual chlorine, remove it by adding 1 drop (0.05ml) NaAsO₂ solution 0.1 mg Cl₂ and mix. NaAsO₂ conc. should not exceed 1300 mg/L to avoid error due to NaAsO₂. Take suitable aliquot & dilute it to 50 mL.
5. Add acid Zirconyl - SPADNS reagent 10 ml; Mix well and read % transmission or absorbance.
6. Take suitable aliquots of sample either direct or after distillation in Nessler's tubes. Follow the step 5.
7. Calculate the mg F present in the sample using standard curve.

2. Ion Selective Electrode Method

Principle

The fluoride sensitive electrode is of the solid state type, consisting of a lanthanum fluoride crystal; in use it forms a cell in combination with a reference electrode, normally the calomel electrode. The crystal contacts the sample solution at one face and an internal reference solution at the other. A potential is established by the presence of fluoride ions across the crystal, which is measured by a device called ion meter, or by a moder pH meter having an expanded millivolt scale.

The fluoride ion selective electrode can be used to measure the activity or concentration of fluoride in an aqueous sample by use of an appropriate calibration curve. However, fluoride activity depends on the total ionic strength of the sample. The electrode does not respond to bound or complex fluoride. Addition of a buffer solution of high total ionic strength containing a chelate to complex aluminum preferentially overcomes these difficulties.

Interference

Polyvalent cations such as Al (III), Fe (III) and Si (IV) will complex fluoride ions. However, the addition of CDTA (Cyclohexylene diamine tetra acetic acid) preferentially will complex concentrations of aluminum up to 5 mg/L. Hydrogen ion forms complex with fluoride, while hydroxide ion interferes with electrode response. By adjusting the pH between 5 to 8 no interference occurs.

Apparatus

1. Ion meter (field / laboratory model) or pH/mV meter for precision laboratory measurements.
2. Reference electrode (calomel electrode)
3. Fluoride sensitive electrode.
4. Magnetic stirrer.
5. Plastic labware (Samples and standards always be stored in plastic containers as fluoride reacts with glass).

Reagents

1. Standard fluoride solution prepared as directed in SPADNS method.
2. Total Ionic strength adjustment buffer (TISAB).

Place approximately 500 ml distilled water in a 1 - L beaker add 57 mL glacial acetic acid, 58 gm NaCl and 4.0 gm 1, 2 cyclohexylene diamine tetraacetic acid. Stir to dissolve. Place beaker in a cool water bath and add slowly 6 N NaOH (About 125 ml) with stirring, until pH is between 5 and 5.5. Transfer to a 1 - L volumetric flask and make up the volume to the mark.

Procedure

1. For connecting the electrodes to meter, and for further operation of the instrument, follow the instruction manual supplied by the manufacturer.
2. Check the electrode slope with the ion meter (59.16 mV for monovalent ions and 29.58 mV for diavalent ions at 25°C)
3. Take 50 ml of each 1 ppm and 10 ppm fluoride standard. Add 50 ml TISAB (or 5 ml if conc. TISAB is used) and calibrate the instrument.
4. Transfer 50 to 100 ml of sample to a 150 ml plastic beaker. Add TISAB as mentioned in (3).
5. Rinse electrode, blot dry and place in the sample. Stir thoroughly and note down the steady reading on the meter.
6. Recalibrate every 1 or 2 hours.
7. Direct measurement is a simple procedure for measuring a large number of samples. The temperature of samples and standard should be the same and the ionic strength of standard and samples should be made the same by addition of TISAB to all solutions.
8. Direct measurement results can be verified by a known addition procedure. The known addition procedure involves adding a standard of known concentration to a sample solution. From the change in electrode potential before and after addition, the original sample concentration is determined.

Fluoride SPADNS Method

References:

APHA Standard Methods, 20th ed., p. 4-82, method 1500 F-(1998).

EPA Methods for Chemical Analysis of Water and Wastes, method 340.1 (1974,1978).

Thomas and Chamberlain, 1974, Colorimetric Analytical Methods, pp 186-193.

The Fluoride Vacu-vials[®] test method is based on the reaction between fluoride and a red zirconium-dye lake that has been formed with SPADNS. The loss of color resulting from the reaction of the fluoride with the dye lake is a function of the fluoride concentration. Results are expressed in ppm (mg/Liter) F⁻.

This method is approved by the EPA for NPDES and NPDWR reporting purposes when the samples have been distilled from an acid solution. Seawater and wastewater samples must be pre-distilled. Distillation removes most contaminating interferences except chlorine. Sodium Arsenite has been added to remove up to 5 mg/L chlorine.

Oxygen (dissolved)

References: Indigo Carmine--ASTM D 888-87, Colorimetric Indigo Carmine, Test Method A. Gilbert, T.W., Behymer, T.D., Castaneda, H.B., "Determination of Dissolved Oxygen in Natural and Wastewaters," *American Laboratory*, March 1982, pp. 119-134. Rhodazine D method--(Method developed by CHEMetrics, Inc.) Power Plant Manual, First ed., p. 169 (1984).

ASTM D 5543-94, Standard Test Methods for Low Level Dissolved Oxygen in Water.

The level of dissolved oxygen in natural waters is often a direct indication of quality, since aquatic plants produce oxygen, while microorganisms generally consume it as they feed on pollutants. At low temperatures the solubility of oxygen is increased, so that in winter, concentrations as high as 20 ppm may be found in natural waters; during summer, saturation levels can be as low as 4 or 5 ppm. Dissolved oxygen is essential for the support of fish and other aquatic life and aids in the natural decomposition of organic matter. Waste treatment plants which employ aerobic digestion must maintain a level of at least 2 ppm dissolved oxygen. This is usually accomplished by mechanical aeration.

At elevated temperatures, oxygen is highly corrosive to metals, causing "**pitting**" in ferrous systems such as high-pressure boilers and deep well oil recovery equipment. To prevent costly corrosion damage, the liquids in contact with the metal surfaces must be treated, usually by a combination of physical and chemical means. De-aeration can reduce the dissolved oxygen concentration of boiler feedwater from several ppm to a few ppb. Chemical reducing agents such as hydrazine or sodium sulfite are sometimes used instead of de-aeration, but more often are used to react with residual oxygen which remains after the de-aeration process.

The Colorimetric Methods.

Test kits for environmental and drinking water applications (ppm range) employ the indigo carmine method. The reduced form of indigo carmine reacts with D.O. to form a blue product. The indigo carmine methodology is not subject to interferences from temperature, salinity or dissolved gases such as sulfide, which plague users of D.O. meters. Results are expressed as ppm (mg/L) O₂.

Test kits for boiler waters and applications requiring trace levels of D.O. (ppb range) employ the Rhodazine D methodology. Developed by CHEMetrics, Inc., the Rhodazine D compound in reduced form reacts with dissolved oxygen to form a bright pink reaction product. This method is not subject to the temperature, salinity, or dissolved gas interferences which plague dissolved oxygen meters. Oxidizing agents, including benzoquinone, can cause high results. Reducing agents such as hydrazine and sulfite do not interfere. Results are expressed as ppm (mg/L) or ppb (µg/L) O₂.

The dissolved oxygen products provide fast, accurate colorimetric oxygen determination. Test kit K-7512 is used to monitor surface waters. ULR CHEMets™ ampoules detect oxygen to 1 ppb. Test kit K-7540 is widely used to monitor boiler feedwater.

Boiler feedwater testing: Low range dissolved oxygen test kits include a special "**sampling tube**" (see diagram) for use with boiler feedwater. This device allows the user to break the tip of the ampoule in a flowing sample stream in order to preclude error from contamination by atmospheric oxygen.

Total Dissolved Solids (Filterable)

The dissolved (Filterable) solids can be determined from the difference between the residue on evaporation and total suspended solids, but if the dissolved solids content is low and the suspended solids high, a direct determination is better. It is preferable to adopt the centrifugal method of separating suspended matter in order that a sufficiently large volume of separated liquid is available for the determination.

Principle

A known volume of filtered sample is evaporated and dried in a weighed dish at 105°C to constant weight; the increase in weight over the empty dish represents the dissolved solids.

Apparatus

1. Evaporating dishes, 50, 100 mL capacity (Preferably porcelain or silica).
2. Pipettes 25, 50 ml capacity
3. Water bath & Oven
4. Balance to weigh up to 4th decimal.

Procedure

The known volume (V) of filtered sample in a previously ignited and weighed basin (W_1). Evaporate to dryness on a steam bath and further dry at 105°C for one or two hours in an oven. Cool in dessicator and weight (W_2). Repeat by further heating for 15 minutes and cooling until successive results do not differ by more than about 0.4 mg.

Calculation

$$\text{Dissolved solids mg/L} = \frac{(W_2 - W_1) \times 1000}{V}$$

Where

W_2 = Weight of residue and dish

W_1 = Weight of empty and dry dish

V = Weight of sample

Ozone

Reference:

DDPD method: Developed by CHEMetrics, Inc.

Indigo method: Bader, H. and Hoigne, J., "Determination of Ozone in Water by the Indigo Method," Water Research, Vol. 15, 449-456, 1981. APHA Standard Methods, 20th ed., p. 4-137, Method 4500-03 B (1998).

Ozone is a strong oxidizing agent. Ozonation is used as an alternative biocide and disinfectant to chlorination of drinking water. Ozone is used to remove odor, decolorize, and to control algae and other aquatic growths. Because ozone is unstable in water, monitoring ozone residuals is important to ensure that proper treatment levels are maintained.

The Colorimetric Methods

The DPD chemistry employs a methyl substituted form of the DPD reagent. The A-7400 activator solution (potassium iodide) is added to the sample before analysis. Ozone reacts with the iodide to liberate iodine. The iodine then reacts with the reagent to give a blue-violet

color. Various free halogens and halogenating agents produce color with the reagent. Chromate in test samples below 25 ppm will not interfere with results. Results are expressed as ppm (mg/L) O_3 . The new ozone method employs the indigo trisulfonate reagent, which reacts instantly and quantitatively with ozone, bleaching the blue color in direct proportion to the amount of ozone present. Malonic acid is included in the formulation to prevent interference from chlorine. Results are expressed as ppm (mg/L) O_3 .

Turbidity

Suspension of particles in water interfering with passage of light is called turbidity. Turbidity is caused by wide variety of suspended matter which range in size from colloidal to coarse dispersions, depending upon the degree of turbulence, and also ranges from pure inorganic substances to those that are highly organic in nature. Turbid waters are undesirable from an aesthetic point of view in drinking water supplies and may also affect products in industries. Turbidity is measured to evaluate the performance of water treatment plants.

Principle

Turbidity can be measured either by its effect on the transmission of light, which is termed as Turbidimetry, or by its effect on the scattering of light, which is termed as Nephelometry. A Turbidimeter can be used for samples with moderate turbidity, and a Nephelometer for samples with low turbidity. The higher the intensity of scattered light, the higher the turbidity.

Interference

Color is the main source of interference in the measurement of turbidity.

Apparatus : Turbidimeter or Nephelometer.

Reagents

1. Solution I : Dissolve 1.0 gm Hydrazine Sulfate and dilute to 100 mL.
2. Solution II : Dissolve 10.0 gm Hexamethylene tetramine and dilute to 100 mL.
3. Mix 5 mL of I with 5 mL of II. Allow to stand for 24 hrs. at $25 \pm 3^\circ C$ and dilute to 100 mL. This solution (III) will have turbidity of 400 units (N.T.U.)
4. Standard turbidity suspension: Dilute 10 mL of solution III as prepared above to 100 mL to have solution of the turbidity of 40 units. (N.T.U.)

Procedure

1. Prepare calibration curve in the range of 0-400 units by carrying out appropriate dilutions of solutions III and IV above taking readings on turbidimeter.
2. Take sample or a suitably diluted aliquot and determine its turbidity either by visual comparison with the diluted standards or by reading on turbidimeter.
3. Read turbidity from the standard curves and apply correction due to dilution, if necessary.
4. Report the readings in turbidity units.

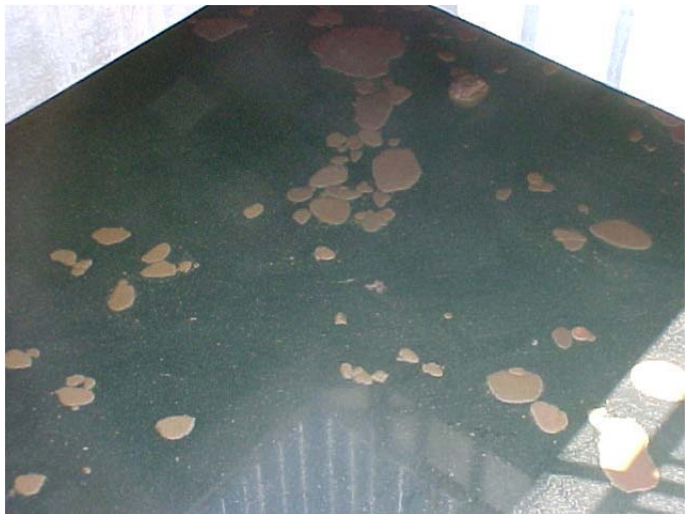

Standard Operating Procedure for the Determination of Total Organic Carbon in Water

1.0 Scope and Application

This method is used to determine total organic carbon (**TOC**) in water. A concentration of 0.01 mg/L can be measured by some instruments if scrupulous attention is given to minimizing sample contamination and method background.

2.0 Summary of Method

There are two different ways to determine total organic carbon (TOC). The first way is by the TOC mode. The inorganic carbon (IC) is first removed from the sample by acidification and sparging and then the organic carbon (OC) is oxidized to carbon dioxide (CO₂) by sodium persulfate in the presence of ultraviolet light. The CO₂ produced is purged from the sample, dried, and transferred with a carrier gas to a non-dispersive infrared (NDIR) analyzer that is specifically tuned to the absorptive wavelength of CO₂. The instrument's microprocessor converts the detector signal to organic carbon concentrations in mg/L based on stored calibration data. The second way is TOC by difference. This is just total carbon (TC) minus inorganic carbon. The TC is all the carbon in the sample, both IC and OC. The IC is determined in the same manner as in the TOC mode.

3.0 Definitions

3.1 The definitions and purposes below are specific to this method, but have been conformed to common usage as much as possible.

3.2 Liter: L

Milliliter: mL

Grams: g

Total Organic Carbon: TOC

Total Carbon: TC

Inorganic Carbon: IC

Organic Carbon: OC

Carbon Dioxide: CO₂

Non dispersive infrared: NDIR

Dissolved organic carbon: DOC

3.3 May: This action, activity, or procedural step is neither required nor prohibited. **May not:** This action, activity, or procedural step is prohibited. **Must:** This action, activity, or procedural step is required. **Shall:** This action, activity, or procedural step is required. **Should:** This action, activity, or procedural step is suggested, but not required

4.0 Interferences

4.1 Removal of carbonate and bicarbonate by acidification and purging with purified gas results in the loss of volatile organic substances. The volatiles also can be lost during sample blending, particularly if the temperature is allowed to rise. Another important loss can occur if large carbon-containing particles fail to enter the needle used for injection.

Filtration, although necessary to eliminate particulate organic matter when only dissolved organic carbon (DOC) is to be determined, can result in loss or gain of DOC, depending on the physical properties of the carbon-containing compounds and adsorption and desorption of the carbon matter on the filter. Avoid contaminated glassware, plastic containers, and rubber tubing. Insufficient acidification will result in incomplete release of CO₂.

4.2 The intensity of the ultraviolet light reaching the sample matrix may be reduced by highly turbid samples or with aging of the ultraviolet source, resulting in sluggish or incomplete oxidation. Large organic particles or very large or complex organic molecules such as tannins, lignins, and humic acid may be oxidized slowly because persulfate oxidation is rate-limited. However, oxidation of many large biological molecules such as proteins and monoclonal antibodies proceeds rapidly.

4.3 Persulfate oxidation of organic molecules is slowed in samples containing sufficient concentrations of chloride by the preferential oxidation of chloride; at concentrations above 0.05% chloride, oxidation of organic matter may be inhibited. To remove this interference add mercuric nitrate to the persulfate solution in UV-persulfate instruments, or extend reaction time and/or increase amount of persulfate solution in heated persulfate instruments.

4.4 With any organic carbon measurement, contamination during sample handling and treatment is a likely source of interference. This is especially true of trace analysis. Take extreme care in sampling, handling and analysis of samples below 1 mg/L TOC.

5.0 Safety

5.1 This method does not address all safety issues associated with its use. The laboratory is responsible for maintaining a safe work environment and a current awareness file of OSHA regulations regarding the safe handling of the chemicals specified in this method. A reference file of material safety data sheets for each chemical used in this method should be available to all personnel involved in these analyses.

5.2 Each chemical should be treated as a potential health hazard. Exposure to these chemicals should be reduced to the lowest possible level. It is suggested that the laboratory perform personal hygiene monitoring of each analyst using this method and that the results of this monitoring be made available to the analyst.

5.3 Unknown samples may contain high concentrations of volatile compounds. Sample containers should be opened in a hood and handled with gloves to prevent exposure.

6.0 Equipment and Supplies

Note: Brand names, suppliers, and part numbers are cited for illustrative purposes only. No endorsement is implied. Equivalent performance may be achieved using equipment and materials other than those specified here, but demonstration of equivalent performance that meets the requirements of this method is the responsibility of the laboratory.

6.1 Tekmar-Dohrman Phoenix 8000 TOC uv-persulfate analyzer or other comparable brand with autosampler.

6.2 0-14 pH paper.

6.3 10 ml syringe.

6.4 0.45 micron glass fiber filters.

6.5 125 ml sample bottles:

6.6 Autosampler vials: 40 mL amber glass vials with Teflon-faced septa. These vials should be washed with laboratory detergent and thoroughly rinsed with tap water followed by reverse osmosis water and allowed to dry. The vials should then be rinsed with acetone followed by hexane and allowed to dry. Finally, the vials should be dried in the drying oven used for drying vials used for the analysis of volatile organic compounds.

7.0 Reagents and Standards

7.1 Reagent water: ultrapure from the spectroscopy lab.

7.2 21% phosphoric acid: add 37 ml of 85% phosphoric acid to 188 ml of reagent water. Always add acid to water.

7.3 LabChem Inc. Catalog number LC12910-1 Organic carbon stock solution. 1000 parts per million. Primary standard grade. 1mL=1mg. If it is prepared in the laboratory, it should be preserved by adding phosphoric acid until the pH is <2.

This stock standard solution is used with drinking water samples.

7.4 Inorganic carbon stock solution: Dissolve 4.4122 g anhydrous sodium carbonate, in reagent water, add 3.4970 g anhydrous sodium bicarbonate and dilute to 1000 mL; 1mL=1mg carbon. Keep tightly stoppered. Do not acidify. Used for analysis of surface waters in determining TOC by difference. To make the standards use 4 mL to make 20 ppm, 20 mL for 100 ppm, and 40 mL for 200 ppm. There are different methods in the Phoenix 8000 that can be used. Choose the one that best suits the samples involved.

7.5 Carrier gas. This lab uses nitrogen, CO₂-free and containing less than 1 ppm hydrocarbon.

7.6 Purging gas. Any gas free of CO₂ and hydrocarbons. This lab uses nitrogen.

7.7 Persulfate solution. Acros. 98+ %. Add 25 g of sodium persulfate to 213 mL of reagent water and add 9 mL of phosphoric acid.

8.0 Sample Collection, Preservation, and Storage

8.1 If possible, rinse bottles with sample before filling.

8.2 Collect and store samples in glass bottles protected from sunlight and seal with TFE-backed septa. Preferably use thick silicone rubber-backed TFE septa with open ring caps to produce a positive seal. Before use, wash bottles with laboratory detergent, rinse thoroughly with tap and reverse osmosis water and allow to dry. Then rinse with acetone and hexane and dry in the oven used for drying vials used for analysis of volatile organic carbon compounds. Analyze a bottle blank with each set of sample bottles to determine effectiveness or necessity of cleaning. This can be done by filling a sample bottle (bottle blank) with reagent water in the laboratory when the sample containers are shipped out and holding the sample bottle at 0-4 degrees C until the associated samples are analyzed.

8.3 Drinking water-related samples must either be analyzed or must be acidified to achieve pH <2.0 by addition of minimal phosphoric or sulfuric acid as soon as practical after sampling, not to exceed 24 hours. Check pH before analysis by using a stirring rod to dip in the container and then touch it to the pH paper. If the sample is a groundwater sample, it should not be acidified because there would be a loss of inorganic carbon from the sample in the form of CO₂. Regardless of what is being analyzed, all samples must be stored at 0 - 4 degrees C from the time of collection until analysis.

8.4 All samples must be analyzed within 28 days of the date and time collected.

9.0 Quality Control

9.1 For every set of ten samples, analyze a reagent blank, a known-value check sample, and a duplicate. Analysis of blanks is to show freedom from contamination.

9.2 Analyze a sample bottle blank with each set of samples. See section 8.2 for details.

10.0 Calibration and Standardization

10.1 Use the standard described in section 7.4 for finding TC. If only TOC is to be found, there is a stock solution of organic carbon. The same concentrations can be made up for the organic carbon.

10.2 Depending on whether TC-IC is to be found or TOC is to be found, will determine what curve or curves need to be set active. If just TOC is to be found, then choose SETUP, CALIBRATION, SET ACTIVE, then choose TOC. It will then give ranges of different values.

The choice that has been used is 20ppm-200ppm for most samples. If TOC is found by way of TC-IC, both curves for TC and IC must be set active. They also must have the same range of calibration. The TOC range should not be set active.

10.3 Once the calibration curve is formed, stop the run and go to the calibration results. Choose the standards that have just been run and click on the RECALC button. If you want to keep the curve, click on OK and then start the run again. The curve is supposed to be linear, so the closer to 1.0000 the better the curve.

11.0 Procedure

11.1 Filtration of drinking water-related samples prior to TOC analysis is not permitted as this could result in removal of organic carbon. Where turbidity interferes with TOC analysis, samples should be homogenized and, if necessary, diluted with organic-free reagent water.

11.2 Bring the analytical batch of samples to room temperature. Make sure the samples are homogenized and pour into labeled amber 40 mL vials. Put on a new septa and place on the rack.

11.3 Check the carbonate and bicarbonate levels of the samples to be analyzed. If they are over 800 mg/L then dilute.

11.4 Make up the reagents weekly. Make up new standards when quality control checks start to fail.

11.5 Warm up the instrument at least one-half hour before use. This means just switch from standby to run, and make sure that the gas flow is 200 cc/min. Make sure the baseline has stabilized.

11.6 Create a file and label it according to the current date. An easy way to do this is to load an old file from the setup menu and change the samples that are in it to go along with the new run. Go to the file and use the "save as" and then type in the day of the run. Put the year first then the month and then day. Example: the date of January 21st, 2012 should be read as 120121.

11.7 Set the curve for the desired analysis. The TOC curve should be set for analyzing drinking water-related samples. The TC and IC curve needs to be set active for analysis of TOC by difference. Make sure that all other curves that are not used are not active.

11.8 Put the samples on and select run.

11.9 The calibration curve should be checked after the first standard is run. This will ensure the correct calibration is made. The analyst can choose the points on the calibration menu. The more linear the line the better, so if the r-squared number is close to one, and the check sample is in the tolerance limits, let the rest of the samples run.

11.10 Only TOC results will be displayed for the drinking water-related samples; whereas the TOC by difference will be shown as TC, IC, and TOC on the results portion of the screen.

12.0 Data Analysis, Calculations, and Reporting Results

12.1 Calculations

If the instrument does not already do this, calculate corrected instrument response of standards and samples by subtracting the reagent-water blank instrument response vs. TOC concentration. Subtract procedural blank from each sample instrument response and compare to standard curve to determine carbon content. Apply appropriate dilution factor when necessary. Subtract inorganic carbon from total carbon when TOC is determined by difference.

12.2 Reporting Results

The results can be hand entered or electronically transferred to the Laboratory Information Management System (LIMS). The units should be mg/L.

13.0 Method Performance

Interlaboratory studies of persulfate and/or UV with NDIR detection methods have been conducted in the range of 0.1 mg/L to 4,000 mg/L of carbon. The resulting equation for organic carbon single-operator precision is :

$$S_o = 0.04x + 0.1$$

Overall precision is expressed as: $S_t = 0.08x + 0.1$

where:

S_o = single-operator precision

S_t = overall precision, and

x = TOC concentration, mg/L

14.0 Pollution Prevention

If mercuric nitrate is used to complex the chloride, use an appropriate disposal method for the treated waste to prevent mercury contamination.

15.0 Waste Management

15.1 Disposal of any hazardous waste from this method must be done in accordance with appropriate regulations.

15.2 For further information on waste management, consult *The Waste Management Manual for Laboratory Personnel and Less is Better: Laboratory Chemical Management for Waste Reduction*, both available from the American Chemical society's Department of Government Relations and Science Policy, 1155 16th Street N.W., Washington D.C. 20036

16.0 References

16.1 Method 5310 C: Total Organic Carbon(TOC), Persulfate-Ultraviolet or Heated-Persulfate Oxidation Method, *Standard Methods for the Examination of Water and Wastewater*, 19th edition supplement, 1996, pp.9-14.

16.2 "Dohrman Phoenix 8000 User Manual", 7413 East Kemper Road, Cincinnati, Ohio 45242-9576.

16.3 *Federal Register*, Wednesday, December 16, 1998, p 69417.



Inside a Turbimeter.



Comparison of Arsenic Treatment Technologies

What Technologies Are Used to Treat Arsenic?

This section identifies 13 technologies applicable to arsenic-contaminated soil, waste, and water. Technologies are considered applicable if they have been used at full scale to treat arsenic.

The media treated by these technologies can be grouped into two general categories: soil and waste; and water.

Technologies applicable to one type of soil and waste are typically applicable to other types. For example, solidification/stabilization has been used to effectively treat industrial waste, soil, sludge, and sediment.

Similarly, technologies applicable to one type of water are generally applicable to other types. For example, precipitation/co-precipitation has been used to effectively treat industrial wastewaters, groundwater, and drinking water.

Arsenic Treatment Technologies

Soil and Waste Treatment Technologies

- Solidification/Stabilization
- Vitrification
- Soil Washing/Acid Extraction
- Pyrometallurgical Recovery
- In Situ Soil Flushing

Water Treatment Technologies

- Precipitation/Co-precipitation
- Membrane Filtration
- Adsorption
- Ion Exchange
- Permeable Reactive Barriers

Soil, Waste, and Water Treatment Technologies

- Electrokinetics
- Phytoremediation
- Biological Treatment



What Technologies Are Used Most Often to Treat Arsenic?

This section provides information on the number of treatment projects identified for each technology and estimates of the relative frequency of their application.

The most frequently used technology for soil and waste containing arsenic is solidification/stabilization. The available data show that this technology can effectively meet regulatory cleanup levels, is commercially available to treat both soil and waste, is usually less expensive, and generates a residual that typically does not require further treatment prior to disposal.

Other arsenic treatment technologies for soil and waste are typically used for specific applications. Vitrification may be used when a combination of contaminants are present that cannot be effectively treated using solidification/stabilization. It has also been used when the vitrification residual could be sold as a commercial product.

However, vitrification typically requires large amounts of energy, can be more expensive than S/S, and may generate off-gasses containing arsenic. Soil washing/acid extraction is primarily used to treat soil. However, it is not applicable to all types of soil or to waste. Pyrometallurgical treatment has been used primarily to recycle arsenic from industrial wastes containing high concentrations of arsenic from metals refining and smelting operations. These technologies may not be applicable to soil and waste containing low concentrations of arsenic.

In situ soil flushing treats soil in place, eliminating the need to excavate soil. However, no performance data were identified for the limited number of full-scale applications of this technology to arsenic. For water containing arsenic, the most frequently used technology is precipitation/co-precipitation. Based on the information gathered for this report, precipitation/co-precipitation is frequently used to treat arsenic contaminated water, and is capable of treating a wide range of influent concentrations to the revised MCL for arsenic.

The effectiveness of this technology is less likely to be reduced by characteristics and contaminants other than arsenic, compared to other water treatment technologies. It is also capable of treating water characteristics or contaminants other than arsenic, such as hardness or heavy metals. Systems using this technology generally require skilled operators; therefore, precipitation/ co-precipitation is more cost effective at a large scale where labor costs can be spread over a larger amount of treated water produced. The effectiveness of adsorption and ion exchange for arsenic treatment is more likely than precipitation/co-precipitation to be affected by characteristics and contaminants other than arsenic.

Precipitation/Co-precipitation Process

- **Oxidation/Reduction**
- **(Pretreatment Process)**
- **Groundwater Solids to**
- **Disposal**
- **Sludge**
- **Dewatering**
- **Filtrate**
- **Sludge Sludge**
- **Thickening**
- **Thickener**
- **Overflow**
- **Flocculation pH Adjustment and**
- **Reagent Addition**
- **Polymer Reagent**
- **Effluent**
- **Clarification**

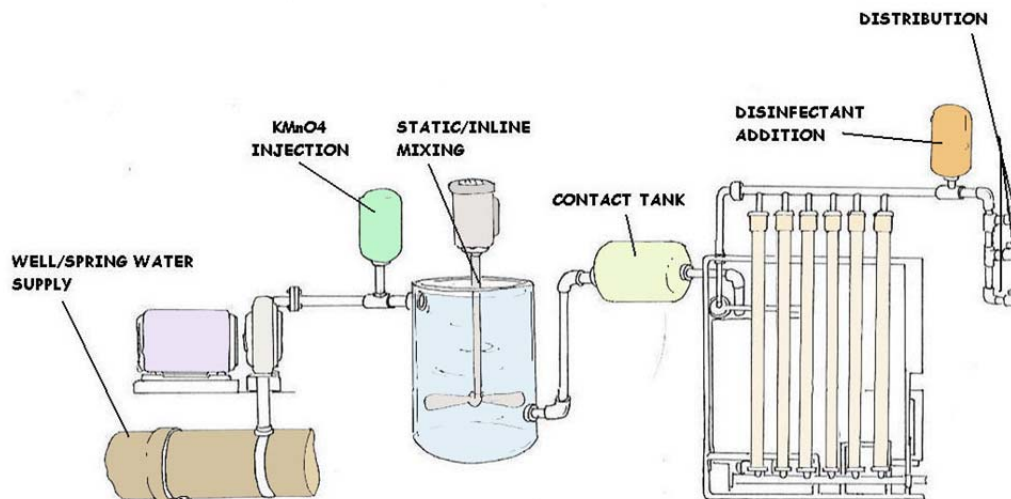

ARSENIC REMOVAL SYSTEM

Precipitation/co-precipitation has been the most frequently used method to treat arsenic contaminated water, including groundwater, surface water, leachate, mine drainage, drinking water, and wastewater in numerous pilot- and full-scale applications. Based on the information collected to prepare this report, this technology typically can reduce arsenic concentrations to less than 0.050 mg/L and in some cases has reduced arsenic concentrations to below 0.010 mg/L.

Technology Description

Precipitation uses chemicals to transform dissolved contaminants into an insoluble solid. In co-precipitation, the target contaminant may be dissolved or in a colloidal or suspended form. Dissolved contaminants do not precipitate, but are adsorbed onto another species that is precipitated. Colloidal or suspended contaminants become enmeshed with other precipitated species, or are removed through processes such as coagulation and flocculation. Many processes to remove arsenic from water involve a combination of precipitation and co-precipitation. The precipitated/co-precipitated solid is then removed from the liquid phase by clarification or filtration. Arsenic precipitation/co-precipitation can use combinations of the chemicals and methods listed below.

Media Treated

- Drinking water
- Groundwater
- Wastewater
- Surface water
- Leachate
- Mine drainage



Chemicals and Methods Used for Arsenic Precipitation/Co-precipitation

- Ferric salts, (e.g., ferric chloride), ferric sulfate, ferric hydroxide
- Ammonium sulfate
- Alum (aluminum hydroxide)
- pH adjustment
- Lime softening, limestone, calcium hydroxide
- Manganese sulfate
- Copper sulfate
- Sulfide

Process Control System

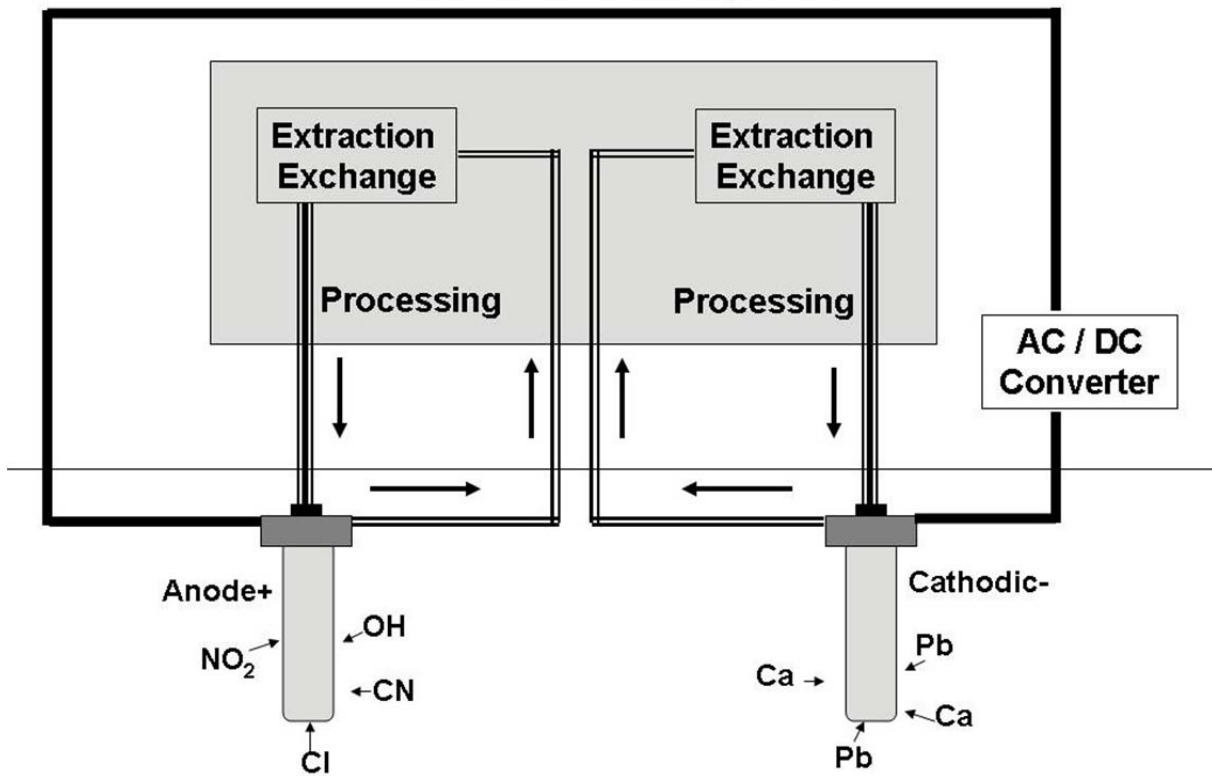

Electro Kinetic Treatment System

Technology Description and Principles

For this report, technologies were considered precipitation/co-precipitation if they involved the following steps:

- Mixing of treatment chemicals into the water.
- Formation of a solid matrix through precipitation, co-precipitation, or a combination of these processes, and
- Separation of the solid matrix from the water.

Technologies that remove arsenic by passing it through a fixed bed of media, where the arsenic may be removed through adsorption, precipitation/co-precipitation, or a combination of these processes, are discussed in the adsorption treatment section. Precipitation/co-precipitation usually involves pH adjustment and addition of a chemical precipitant or coagulant; it can also include addition of a chemical oxidant. Oxidation of arsenic to its less soluble As(V) state can increase the effectiveness of precipitation/co-precipitation processes, and can be done as a separate pretreatment step or as part of the precipitation process. Some pretreatment processes that oxidize As(III) to As(V) include ozonation, photo oxidation, or the addition of oxidizing chemicals such as potassium permanganate, sodium hypochlorite, or hydrogen peroxide. Clarification or filtration is commonly used to remove the solid precipitate. Precipitation/co-precipitation is frequently used to treat water contaminated with metals.

The references identified for this report contained information on its application to industrial wastewater, groundwater, surface water, leachate, and mine drainage.

Precipitation/Co-precipitation Chemistry

Precipitation Reactions

A **precipitate** is a solid that forms out of solution.

A common example of a precipitation reaction happens when mixing the following two clear solutions:

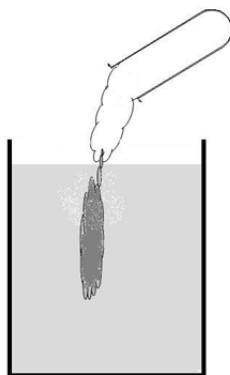

Solvent + Solute = Solution
Silver nitrate (AgNO_3) + Sodium chloride (NaCl) = AgCl precipitate

The chemical equation for this reaction is ...



The precipitate forms because the solid product of the reaction (**AgCl**) is **insoluble** in water. That is true for all precipitates - the solids are insoluble in aqueous solutions.

Precipitation reactions occur all around us. For example, sometimes the pipes in our homes get clogged because precipitates of magnesium and calcium oxides have deposited themselves within the pipes. This can happen with "**hard**" water.

Another example is a kidney stone. A kidney stone is nothing more than a precipitate - often of calcium ions (from cheese) and oxalates. It is often suggested that a good way to avoid kidney stones is to drink a lot of water. This helps because the solubility of the precipitate increases with the amount of water - thus avoiding the formation of the kidney stone to begin with.

Complex

The chemistry of precipitation/co-precipitation is often complex, and depends upon a variety of factors, including the speciation of arsenic, the chemical precipitants used and their concentrations, the pH of the water, and the presence of other chemicals in the water to be treated. As a result, the particular mechanism that results in the removal of arsenic through precipitation/co-precipitation treatment is process-specific, and in some cases is not completely understood.

For example, the removal mechanism in the treatment of As(V) with Fe(III) has been debated in the technical literature. It is beyond the scope of this course to provide all possible chemical reactions and mechanisms for precipitation/co-precipitation processes that are used to remove arsenic. More detailed information on the chemistry involved in specific processes can be found in the references listed at the end of this section.

The effectiveness of this technology can be evaluated by comparing influent and effluent contaminant concentrations. All of the 12 environmental media projects for which both influent and effluent arsenic concentration data were available had influent concentrations greater than 0.050 mg/L. The treatments achieved effluent concentrations of less than 0.050 mg/L in eight of the projects and less than 0.010 mg/L in four of the projects. Information on the leachability of arsenic from the precipitates and sludges was available for three projects.

For all of these projects, the concentration of leachable arsenic as measured by the toxicity characteristic leaching procedure (**TCLP**) (the RCRA regulatory threshold for identifying a waste that is hazardous because it exhibits the characteristic of toxicity for arsenic) was below 5.0 mg/L.

Factors Affecting Precipitation/Co-precipitation Performance

- **Valence state of arsenic** - The presence of the more soluble trivalent state of arsenic may reduce the removal efficiency. The solubility of arsenic depends upon its valence state, pH, the specific arsenic compound, and the presence of other chemicals with which arsenic might react (Ref. 9.12). Oxidation to As(V) could improve arsenic removal through precipitation/co-precipitation (Ref. 9.7).

- **pH** - In general, arsenic removal will be maximized at the pH at which the precipitated species is least soluble. The optimal pH range for precipitation/co-precipitation depends upon the waste treated and the specific treatment process (Ref. 9.7).
- **Presence of other compounds** - The presence of other metals or contaminants may impact the effectiveness of precipitation/co-precipitation. For example, sulfate could decrease arsenic removal in processes using ferric chloride as a coagulant, while the presence of calcium or iron may increase the removal of arsenic in these processes (Ref. 9.7).



Examples of different water operator's labs.



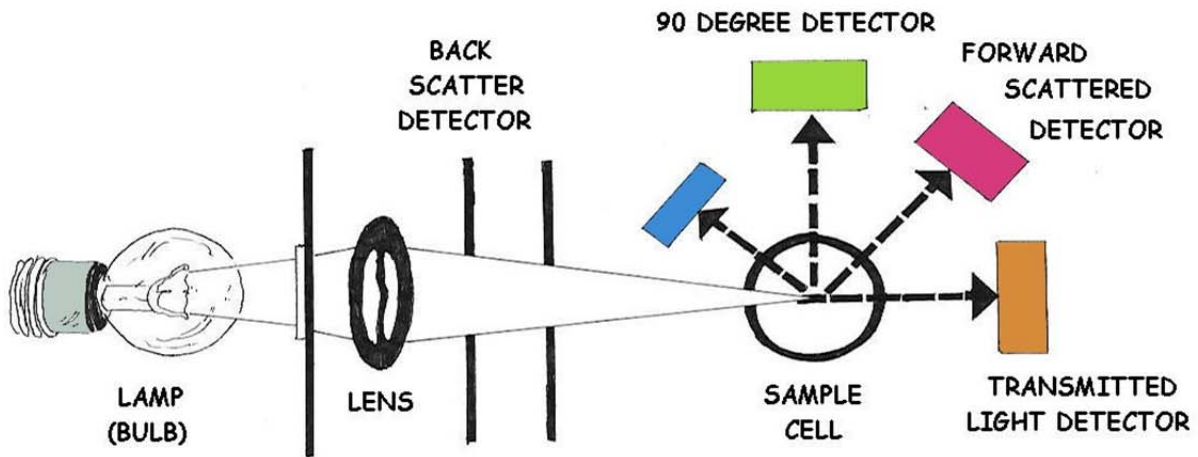

HOW AN TURBIDIMETER WORKS



have typical metallic properties
harder than the Group I metals
higher melting points than the Group I metals

- ✓ **Group III: B, Al, Ga, In, Tl**
boron is a semimetal; all the others are metals
- ✓ **Group IV: C, Si, Ge, Sn, Pb**
carbon is a nonmetal; silicon and germanium are semimetals; tin and lead are metals
- ✓ **Group V: N, P, As, Sb, Bi**
nitrogen and phosphorus are nonmetals; arsenic and antimony are semimetals; bismuth is a metal
- ✓ **Group VI: O, S, Se, Te, Po**
oxygen, sulfur, and selenium are nonmetals; tellurium and polonium are semimetals
- ✓ **Group VII: Halogens-F, Cl, Br, I, At**
very reactive nonmetals
- ✓ **Group VIII: Noble Gases-He, Ne, Ar, Kr, Xe, Rn**
very unreactive

Assignment

How do the properties of metals and nonmetals differ?



The pH Scale

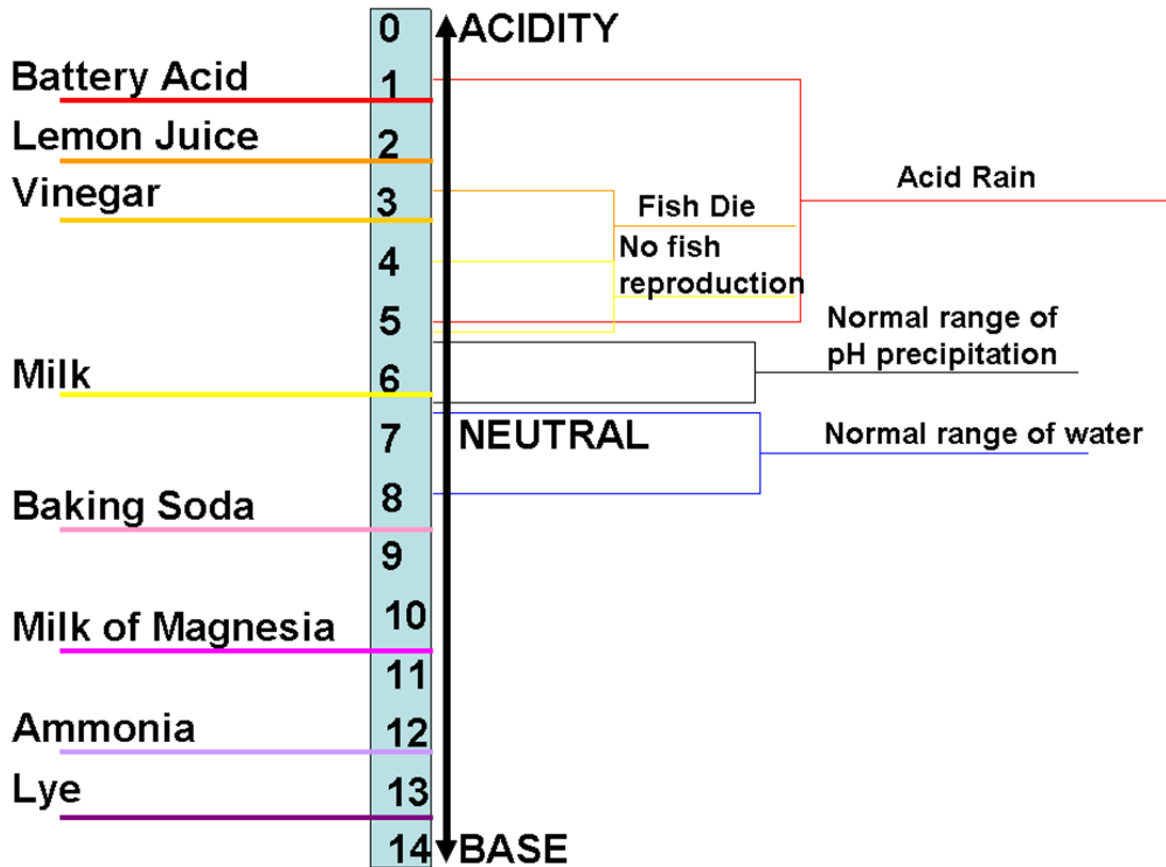

pH: A measure of the acidity of water. The pH scale runs from 0 to 14 with 7 being the mid-point or neutral. A pH of less than 7 is on the acid side of the scale with 0 as the point of greatest acid activity. A pH of more than 7 is on the basic (alkaline) side of the scale with 14 as the point of greatest basic activity.

pH = (Power of Hydroxyl Ion Activity).

The acidity of a water sample is measured on a pH scale. This scale ranges from **0** (maximum acidity) to **14** (maximum alkalinity). The middle of the scale, **7**, represents the neutral point. The acidity increases from neutral toward **0**.

Because the scale is logarithmic, a difference of one pH unit represents a tenfold change. For example, the acidity of a sample with a pH of **5** is ten times greater than that of a sample with a pH of **6**. A difference of 2 units, from **6** to **4**, would mean that the acidity is one hundred times greater, and so on.

Normal rain has a pH of **5.6** – slightly acidic because of the carbon dioxide picked up in the earth's atmosphere by the rain.

Sampling Plan

A written sampling plan must be developed by the water system. These plans will be reviewed by the Health Department or State Drinking Water agency during routine field visits for sanitary surveys or technical assistance visits. This plan should include:

1. The location of routine sampling sites on a system distribution map. You will need to locate more routine sampling sites than the number of samples required per month or quarter. A minimum of three sites is advised and the sites should be rotated on a regular basis.
2. Map the location of repeat sampling sites for the routine sampling sites. Remember that repeat samples must be collected within five (5) connections upstream and downstream from the routine sample sites.
3. Establish a sampling frequency of the routine sites.
4. Sampling technique, establish a minimum flushing time and requirements for free chlorine residuals at the sites (if you chlorinate continuously).

The sampling sites should be representative of the distribution network and pressure zones. If someone else, e.g., the lab, collects samples for you, you should provide them with a copy of your sampling plan and make sure they have access to all sample sites.



Grabbing a sample from a stream.

Bacteriological Monitoring Section

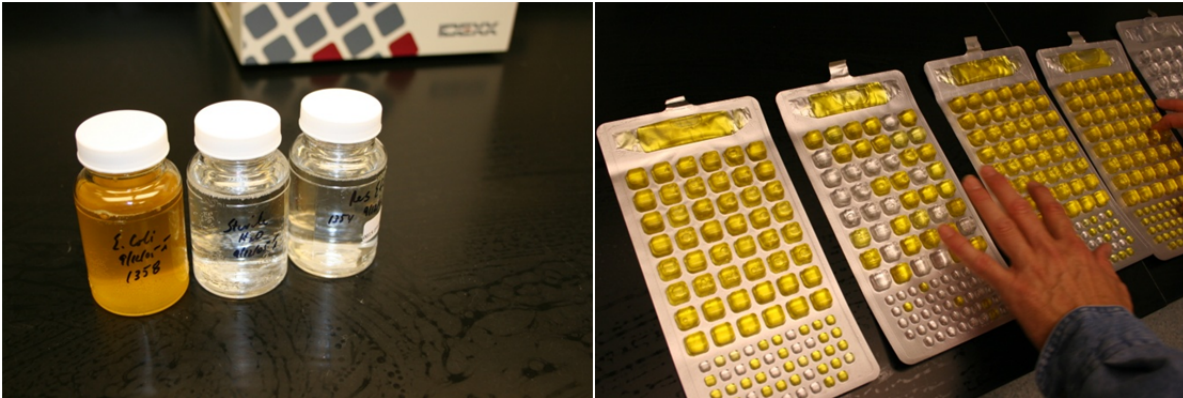

Looking under a black light to identify the presence of E. coli.

Colilert tests simultaneously detect and confirms coliform and E. coli in water samples in 24 hours or less.

Simply add the Colilert reagent to the sample, incubate for 24 hours, and read results.

Colilert is easy to read, as positive coliform samples turn yellow or blue, and when E. coli is present, samples fluoresce under UV light.

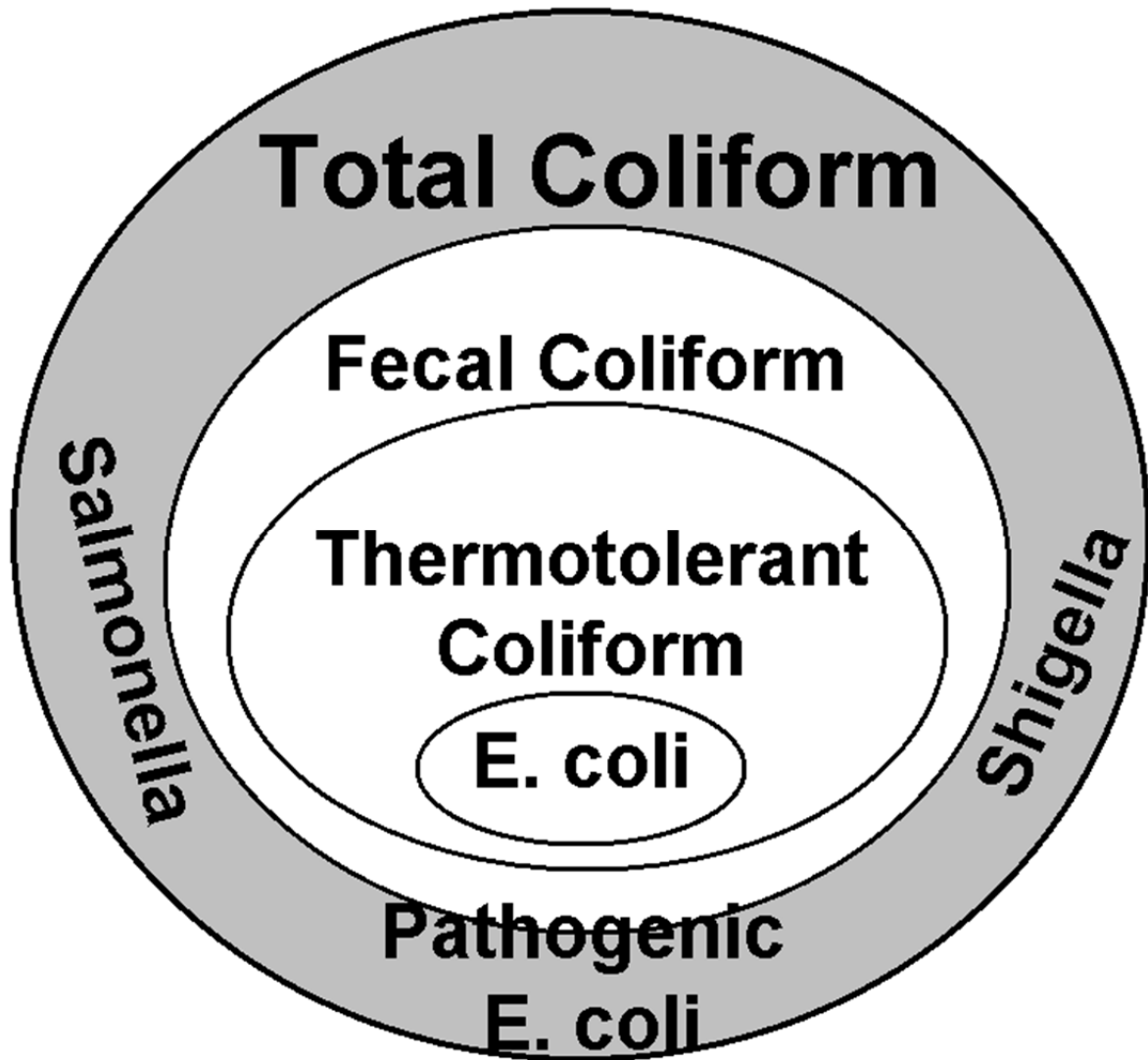

Bacteriological Monitoring Section

Most waterborne diseases and illnesses have been related to the microbiological quality of drinking water. The routine microbiological analysis of your water is for coliform bacteria. The coliform bacteria group is used as an indicator organism to determine the biological quality of your water. The presence of an indicator or pathogenic bacteria in your drinking water is an important health concern. Indicator bacteria signal possible fecal contamination, and therefore, the potential presence of pathogens. They are used to monitor for pathogens because of the difficulties in determining the presence of specific disease-causing microorganisms.

Indicator bacteria are usually harmless, occur in high densities in their natural environment, and are easily cultured in relatively simple bacteriological media. Indicators in common use today for routine monitoring of drinking water include total coliforms, fecal coliforms, and *Escherichia coli* (*E. coli*).

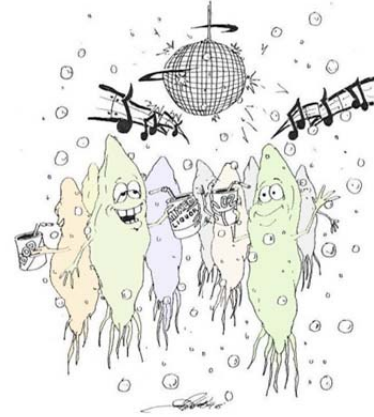

Bacteria Sampling

Water samples for bacteria tests must always be collected in a sterile container. Take the sample from an inside faucet with the aerator removed. Sterilize by spraying a 5% Household bleach or alcohol solution or flaming the end of the tap with a propane torch. Run the water for five minutes to clear the water lines and bring in fresh water. Do not touch or contaminate the inside of the bottle or cap. Carefully open the sample container and hold the outside of the cap. Fill the container and replace the top. Refrigerate the sample and transport it to the testing laboratory within six hours (in an ice chest). Many labs will not accept bacteria samples on Friday so check the lab's schedule. Mailing bacteria samples is not recommended because laboratory analysis results are not as reliable. Iron bacteria forms an obvious slime on the inside of pipes and fixtures. A water test is not needed for identification. Check for a reddish-brown slime inside a toilet tank or where water stands for several days.

Bac-T Sample Bottle Often referred to as a Standard Sample, 100 mls, notice the white powder inside the bottle. That is Sodium Thiosulfate, a de-chlorination agent. Be careful not to wash-out this chemical while sampling. Notice the custody seal on the bottle.

Coliform bacteria are common in the environment and are generally not harmful. However, the presence of these bacteria in drinking water is usually a result of a problem with the treatment system or the pipes which distribute water, and indicates that the water may be contaminated with germs that can cause disease.

Laboratory Procedures

The laboratory may perform the total coliform analysis in one of four methods approved by the U.S. EPA and your local environmental or health division:

Methods

The MMO-MUG test, a product marketed as Colilert, is the most common. The sample results will be reported by the laboratories as simply coliforms present or absent. If coliforms are present, the laboratory will analyze the sample further to determine if these are fecal coliforms or *E. coli* and report their presence or absence.

Types of Water Samples

It is important to properly identify the type of sample you are collecting. Please indicate in the space provided on the laboratory form the type of sample.

The three (3) types of samples are:

1. **Routine:** Samples collected on a routine basis to monitor for contamination. Collection should be in accordance with an approved sampling plan.
2. **Repeat:** Samples collected following a '**coliform present**' routine sample. The number of repeat samples to be collected is based on the number of routine samples you normally collect.
3. **Special:** Samples collected for other reasons. Examples would be a sample collected after repairs to the system and before it is placed back into operation or a sample collected at a wellhead prior to a disinfection injection point.

Routine Coliform Sampling

The number of routine samples and frequency of collection for community public water systems is shown in Table 3-1 below.

Noncommunity and nontransient noncommunity public water systems will sample at the same frequency as a like sized community public water system if:

1. It has more than 1,000 daily population and has ground water as a source, or
2. It serves 25 or more daily population and utilizes surface water as a source or ground water under the direct influence of surface water as its source.

Noncommunity and nontransient, noncommunity water systems with less than 1,000 daily population and groundwater as a source will sample on a quarterly basis.

Water Quality Review Statements

- ✓ What are disease causing organisms such as bacteria and viruses called? Pathogens
- ✓ Name the 4 broad categories of water quality. Physical, chemical, biological, radiological.
- ✓ What does a positive bacteriological sample indicate? The presence of bacteriological contamination.
- ✓ When must source water monitoring for lead and copper be performed? When a public water system exceeds an action level for lead or copper.

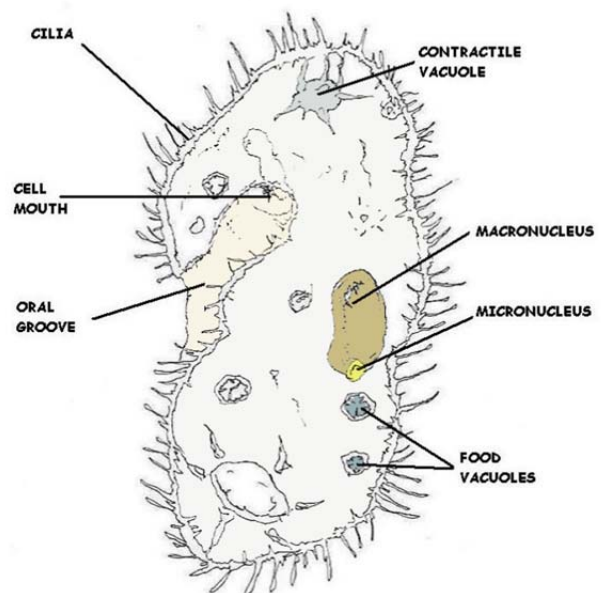

PARAMECIUM

No. of Samples per System Population

Persons served - Samples per month

up to 1,000	1
1,001-2,500	2
2,501-3,300	3
3,301 to 4,100	4
4,101 to 4,900	5
4,901 to 5,800	6
5,801 to 6,700	7
6,701 to 7,600	8
7,601 to 8,500	9
8,501 to 12,900	10
12,901 to 17,200	15
17,201 to 21,500	20
21,501 to 25,000	25
25,001 to 33,000	30
33,001 to 41,000	40
41,001 to 50,000	50
50,001 to 59,000	60
59,001 to 70,000	70
70,001 to 83,000	80
83,001 to 96,000	90
96,001 to 130,000	100
130,001 to 220,000	120
220,001 to 320,000	150
320,001 to 450,000	180
450,001 to 600,000	210
600,001 to 780,000	240



Repeat Sampling

Repeat sampling replaces the old check sampling with a more comprehensive procedure to try to identify problem areas in the system. Whenever a routine sample has total coliform or fecal coliform present, a set of repeat samples must be collected within 24 hours after being notified by the laboratory. The follow-up for repeat sampling is:

1. If only one routine sample per month or quarter is required, four (4) repeat samples must be collected.
2. For systems collecting two (2) or more routine samples per month, three (3) repeat samples must be collected.
3. Repeat samples must be collected from:
 - a. The original sampling location of the coliform present sample.
 - b. Within five (5) service connections upstream from the original sampling location.
 - c. Within five (5) service connections downstream from the original sampling location.
 - d. Elsewhere in the distribution system or at the wellhead, if necessary.
4. If the system has only one service connection, the repeat samples must be collected from the same sampling location over a four-day period or on the same day.
5. All repeat samples are included in the MCL compliance calculation.
6. If a system which normally collects fewer than five (5) routine samples per month has a coliform present sample, it must collect five (5) routine samples the following month or quarter regardless of whether an MCL violation occurred or if repeat sampling was coliform absent.

Positive or Coliform Present Results

What do you do when your sample is positive or coliform present?

When you are notified of a positive test result you need to contact either the Drinking Water Program or your local county health department within 24 hours, or by the next business day after the results are reported to you. The Drinking Water Program contracts with many of the local health departments to provide assistance to water systems.

After you have contacted an agency for assistance, you will be instructed as to the proper repeat sampling procedures and possible corrective measures for solving the problem. It is very important to initiate the repeat sampling immediately as the corrective measures will be based on those results.



Some examples of typical corrective measures to coliform problems are:

1. Shock chlorination of a ground water well. The recommended dose of 5% household bleach is 2 cups per 100 gallons of water in the well. This should be done anytime the well is opened for repair (pump replacement, etc.). If you plan to shock the entire system, calculate the total gallonage of storage and distribution.
2. Conduct routine distribution line flushing. Install blowoffs on all dead end lines.
3. Conduct a cross connection program to identify all connections with non-potable water sources. Eliminate all of these connections or provide approved backflow prevention devices.
4. Upgrade the wellhead area to meet current construction standards as set by your state environmental or health agency.
5. If you continuously chlorinate, review your operation and be sure to maintain a detectable residual (0.2 mg/l free chlorine) at all times in the distribution system.
6. Perform routine cleaning of the storage system.

This list provides some basic operation and maintenance procedures that could help eliminate potential bacteriological problems, check with your state drinking water section or health department for further instructions.

Maximum Contaminant Levels (MCLs)

State and federal laws establish standards for drinking water quality. Under normal circumstances when these standards are being met, the water is safe to drink with no threat to human health. These standards are known as maximum contaminant levels (**MCL**). When a particular contaminant exceeds its MCL a potential health threat may occur.

The MCLs are based on extensive research on toxicological properties of the contaminants, risk assessments and factors, short term (**acute**) exposure, and long term (**chronic**) exposure. You conduct the monitoring to make sure your water is in compliance with the MCL.

There are two types of MCL violations for coliform bacteria. The first is for total coliform; the second is an acute risk to health violation characterized by the confirmed presence of fecal coliform or E. coli.

Heterotrophic Plate Count

Heterotrophic Plate Count (**HPC**) --- formerly known as the standard plate count, is a procedure for estimating the number of live heterotrophic bacteria and measuring changes during water treatment and distribution in water or in swimming pools. Colonies may arise from pairs, chains, clusters, or single cells, all of which are included in the term "**colony-forming units**" (**CFU**).

Method:

There are three methods for standard plate count:

1. Pour Plate Method

The colonies produced are relatively small and compact, showing less tendency to encroach on each other than those produced by surface growth. On the other hand, submerged colonies often are slower growing and are difficult to transfer.



2. Spread Plate Method

All colonies are on the agar surface where they can be distinguished readily from particles and bubbles. Colonies can be transferred quickly, and colony morphology can be easily discerned and compared to published descriptions.

3. Membrane Filter Method

This method permits testing large volumes of low-turbidity water and is the method of choice for low-count waters.

Material

- i) Apparatus
 - Glass rod
 - Erlenmeyer flask
 - Graduated Cylinder
 - Pipette
 - Petri dish
 - Incubator
- ii) Reagent and sample
 - Reagent-grade water
 - Nutrient agar
 - Sample

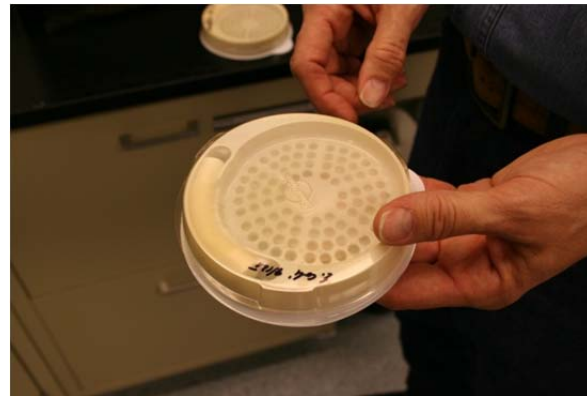

Procedure*

1. Boil mixture of nutrient agar and nutrient broth for 15 minutes, then cool for about 20 minutes.
2. Pour approximately 15 ml of medium in each Petri dish, let medium solidify.
3. Pipette 0.1 ml of each dilution onto surface of pre-dried plate, starting with the highest dilution.
4. Distribute inoculum over surface of the medium using a sterile bent glass rod.
5. Incubate plates at 35°C for 48h.
6. Count all colonies on selected plates promptly after incubation, consider only plates having 30 to 300 colonies in determining the plate count.

*Duplicate samples

Computing and Reporting:

Compute bacterial count per milliliter by the following equation:

$CFU/ml = \text{colonies counted} / \text{actual volume of sample in dish}$ a) If there is no plate with 30 to 300 colonies, and one or more plates have more than 300 colonies, use the plate(s) having a count nearest 300 colonies.

- b) If plates from all dilutions of any sample have no colony, report the count as less than 1/actual volume of sample in dish estimated CFU/ml.
- c) Avoid creating fictitious precision and accuracy when computing CFU by recording only the first two left-hand digits.

Heterotrophic Plate Count (Spread Plate Method)

Heterotrophic organisms utilize organic compounds as their carbon source (food or substrate). In contrast, autotrophic organisms use inorganic carbon sources. The Heterotrophic Plate Count provides a technique to quantify the bacteriological activity of a sample. The R2A agar provides a medium that will support a large variety of heterotrophic bacteria. After an incubation period, a bacteriological colony count provides an estimate of the concentration of heterotrophs in the sample of interest.

Laboratory Equipment Needed

100 x 15 Petri Dishes

Turntable

Glass Rods: Bend fire polished glass rod 45 degrees about 40 mm from one end. Sterilize before using.

Pipette: Glass, 1.1 mL. Sterilize before using.

Quebec Colony Counter

Hand Tally Counter

Reagents

1) R2A Agar: Dissolve and dilute 0.5 g of yeast extract, 0.5 g of proteose peptone No. 3, 0.5 g of casamino acids, 0.5 g of glucose, 0.5 g of soluble starch, 0.3 g of dipotassium hydrogen phosphate, 0.05 g of magnesium sulfate heptahydrate, 0.3 g of sodium pyruvate, 15.0 g of agar to 1 L. Adjust pH to 7.2 with dipotassium hydrogen phosphate **before adding agar**. Heat to dissolve agar and sterilize at 121 C for 15 minutes.

2) Ethanol: As needed for flame sterilization.

Preparation of Spread Plates

Immediately after agar sterilization, pour 15 mL of R2A agar into sterile 100 x 15 Petri dishes; let agar solidify. Pre-dry plates inverted so that there is a 2 to 3 g water loss overnight with the lids on. Use pre-dried plates immediately or store up to two weeks in sealed plastic bags at 4°C.

Sample Preparation

Mark each plate with sample type, dilution, date, and any other information before sample application. Prepare at least duplicate plates for each volume of sample or dilution examined. Thoroughly mix all samples by rapidly making about 25 complete up-and-down movements.



Sample Application

Uncover pre-dried agar plate. Minimize time plate remains uncovered. Pipette 0.1 or 0.5 mL sample onto surface of pre-dried agar plate.

Record Volume of Sample Used.

Using a sterile bent glass rod, distribute the sample over surface of the medium by rotating the dish by hand on a turntable. Let the sample be absorbed completely into the medium before incubating. Put cover back on Petri dish and invert for duration of incubation time. Incubate at 28°C for 7 days. Remove Petri dishes from incubator for counting.

Counting and Recording

After incubation period, promptly count all colonies on the plates. To count, uncover plate and place on Quebec colony counter. Use a hand tally counter to maintain count. Count all colonies on the plate, regardless of size. Compute bacterial count per milliliter by the following equation:

$$\text{CFU/mL} = \frac{\text{colonies counted}}{\text{actual volume of sample in dish, mL}}$$

To report counts on a plate with no colonies, report the count as less than one (<1) divided by the sample volume put on that plate (remember to account for any dilution of that sample).

If plates of all dilutions for a sample have no colonies, report the count as less than one (<1) divided by the largest sample volume used. Example: if 0.1 mL of a 100:1 and 10000:1 dilution of a sample both turned up with no colonies formed, the reported result would be <1 divided by the largest sample volume 0.001 mL (0.1 mL divided by 100). The final reported result for the sample is <1000 CFU per mL.

Assignment

1. Report the number of colony forming units (**CFU**) found on each plate.
2. Calculate the **CFU** per mL for each plate.
3. The aim of diluting samples is to produce a plate having 30 to 300 colonies, which plates meet these criteria. If no sample produces a plate with a count in this range, use the plate(s) with a count closest to 300. Based on these criteria, use your calculated results to report the CFU per mL for each sample.

In the conclusion of your lab report, comment on your final results for each sample type as well as the quality of your application of this analysis technique. Feel free to justify your comments using statistical analysis. Also, comment on the general accuracy of this analytical technique and the factors that affect its accuracy and or applicability.

Data Table for Samples

Sample ID	Volume of Sample, mL	Colonies Counted per plate

Total Coliforms

This MCL is based on the presence of total coliforms, and compliance is on a monthly or quarterly basis, depending on your water system type and state rule. For systems which collect *fewer* than 40 samples per month, no more than one sample per month may be positive. In other words, the second positive result (repeat or routine) in a month or quarter results in an MCL violation.

For systems which collect 40 or more samples per month, no more than five (5) percent may be positive. Check with your state drinking water section or health department for further instructions.

Acute Risk to Health (Fecal Coliforms and E. coli)

An acute risk to human health violation occurs if either one of the following happen:

1. A routine analysis shows total coliform present and is followed by a repeat analysis which indicates fecal coliform or E. coli present.
2. A routine analysis shows total and fecal coliform or E. coli present and is followed by a repeat analysis which indicates total coliform present. An acute health risk violation requires the water system to provide public notice via radio and television stations in the area. This type of contamination can pose an immediate threat to human health and notice must be given as soon as possible, but no later than 72 hours after notification from your laboratory of the test results.

Certain language may be mandatory for both these violations and is included in your state drinking water rule.

Public Notice

A public notice is required to be issued by a water system whenever it fails to comply with an applicable MCL or treatment technique, or fails to comply with the requirements of any scheduled variance or permit. This will inform users when there is a problem with the system and give them information.

A public notice is also required whenever a water system fails to comply with its monitoring and/or reporting requirements or testing procedure. Each public notice must contain certain information, be issued properly and in a timely manner and contain certain mandatory language. The timing and place of posting of the public notice depends on whether an acute risk is present to users. Check with your state drinking water section or health department for further instructions.

The following are Acute Violations

1. Violation of the MCL for nitrate.
2. Any violation of the MCL for total coliforms, when fecal coliforms or E. coli are present in the distribution system.
3. Any outbreak of waterborne disease, as defined by the rules.

Pathogen Section

Bacteria, viruses, and protozoans that cause disease are known as pathogens. Most pathogens are generally associated with diseases that cause intestinal illness and affect people in a relatively short amount of time, generally a few days to two weeks. They can cause illness through exposure to small quantities of contaminated water or food or from direct contact with infected people or animals.

Pathogens that may cause waterborne outbreaks through drinking water have one thing in common: they are spread by the fecal-oral (or feces-to-mouth) route. Pathogens may get into water and spread when infected humans or animals pass the bacteria, viruses, and protozoa in their stool. For another person to become infected, he or she must take that pathogen in through the mouth.

Waterborne pathogens are different from other types of pathogens such as the viruses that cause influenza (the flu) or the bacteria that cause tuberculosis. Influenza virus and tuberculosis bacteria are spread by secretions that are coughed or sneezed into the air by an infected person.

Human or animal wastes in watersheds, failing septic systems, failing sewage treatment plants or cross-connections of water lines with sewage lines provide the potential for contaminating water with pathogens. The water may not appear to be contaminated because feces has been broken up, dispersed and diluted into microscopic particles. These particles, containing pathogens, may remain in the water and be passed to humans or animals unless adequately treated.

Only proper treatment will ensure eliminating the spread of disease. In addition to water, other methods exist for spreading pathogens by the fecal-oral route. The foodborne route is one of the more common methods. A frequent source is a food handler who does not wash his hands after a bowel movement and then handles food with “unclean” hands. The individual who eats feces-contaminated food may become infected and ill. It is interesting to note the majority of foodborne diseases occur in the home, not restaurants.

Day care centers are another common source for spreading pathogens by the fecal-oral route. Here, infected children in diapers may get feces on their fingers, then put their fingers in a friend’s mouth or handle toys that other children put into their mouths. You will usually be asked to sample for **Giardia** at these facilities.

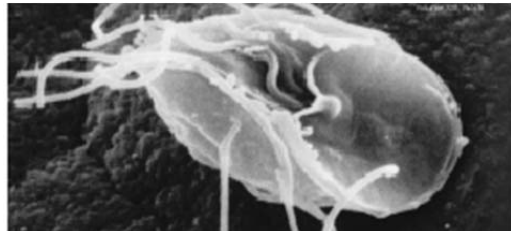

The general public and some of the medical community usually refer to diarrhea symptoms as “**stomach flu.**” Technically, influenza is an upper respiratory illness and rarely has diarrhea associated with it; therefore, stomach flu is a misleading description for foodborne or waterborne illnesses, yet is accepted by the general public. So the next time you get the stomach flu, you may want to think twice about what you’ve digested within the past few days.

Chain of Transmission

Water is contaminated with feces. This contamination may be of human or animal origin. The feces must contain pathogens (disease-causing bacteria, viruses or protozoa). If the human or animal source is not infected with a pathogen, no disease will result. The pathogens must survive in the water. This depends on the temperature of the water and the length of time the pathogens are in the water. Some pathogens will survive for only a short time in water, others, such as Giardia or Cryptosporidium, may survive for months.

The pathogens in the water must enter the water system's intake in numbers sufficient to infect people. The water is either not treated or inadequately treated for the pathogens present. A susceptible person must drink the water that contains the pathogen; then illness (disease) will occur. This chain lists the events that must occur for the transmission of disease via drinking water. By breaking the chain at any point, the transmission of disease will be prevented.

Bacterial Diseases

Campylobacteriosis is the most common diarrheal illness caused by bacteria. Other symptoms include abdominal pain, malaise, fever, nausea and vomiting; and begin three to five days after exposure. The illness is frequently over within two to five days and usually lasts no more than 10 days. **Campylobacteriosis** outbreaks have most often been associated with food, especially chicken and un-pasteurized milk, as well as un-chlorinated water. These organisms are also an important cause of "**travelers' diarrhea**." Medical treatment generally is not prescribed for campylobacteriosis because recovery is usually rapid.

Cholera, Legionellosis, salmonellosis, shigellosis, yersiniosis, are other bacterial diseases that can be transmitted through water. All bacteria in water are readily killed or inactivated with chlorine or other disinfectants.

Viral Diseases

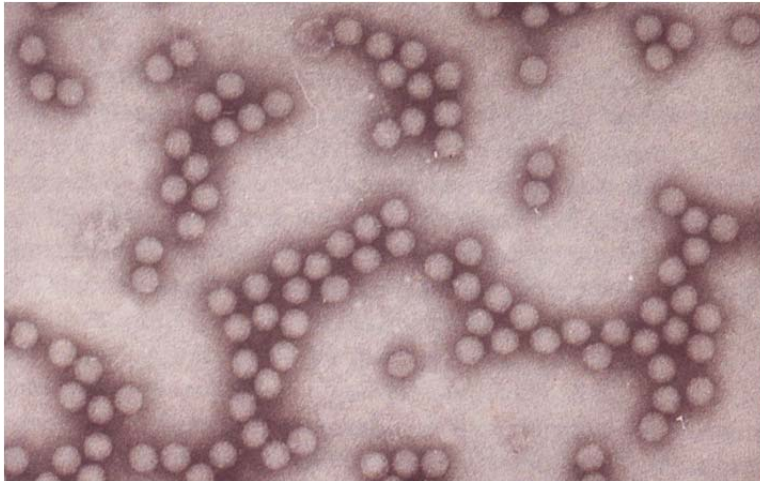

Hepatitis A is an example of a common viral disease that may be transmitted through water. The onset is usually abrupt with fever, malaise, loss of appetite, nausea and abdominal discomfort, followed within a few days by jaundice. The disease varies in severity from a mild illness lasting one to two weeks, to a severely disabling disease lasting several months (rare). The incubation period is 15-50 days and averages 28-30 days. Hepatitis A outbreaks have been related to fecally contaminated water; food contaminated by infected food handlers, including sandwiches and salads that are not cooked or are handled after cooking, and raw or undercooked mollusks harvested from contaminated waters. Aseptic meningitis, polio and viral gastroenteritis (**Norwalk agent**) are other viral diseases that can be transmitted through water. Most viruses in drinking water can be inactivated by chlorine or other disinfectants.

Protozoan Diseases

Protozoan pathogens are larger than bacteria and viruses, but still microscopic. They invade and inhabit the gastrointestinal tract. Some parasites enter the environment in a dormant form, with a protective cell wall called a “**cyst**.” The cyst can survive in the environment for long periods of time and be extremely resistant to conventional disinfectants such as chlorine. Effective filtration treatment is therefore critical to removing these organisms from water sources.



Giardia lamblia

Giardiasis is a commonly reported protozoan-caused disease. It has also been referred to as “**backpacker’s disease**” and “**beaver fever**” because of the many cases reported among hikers and others who consume untreated surface water. Symptoms include chronic diarrhea, abdominal cramps, bloating, frequent loose and pale greasy stools, fatigue and weight loss. The incubation period is 5-25 days or longer, with an average of 7-10 days. Many infections are asymptomatic (no symptoms). Giardiasis occurs worldwide. Waterborne outbreaks in the United States occur most often in communities receiving their drinking water from streams or rivers without adequate disinfection or a filtration system. The organism, ***Giardia lamblia***, has been responsible for more community-wide outbreaks of disease in the U.S. than any other pathogen. Drugs are available for treatment, but these are not 100% effective.

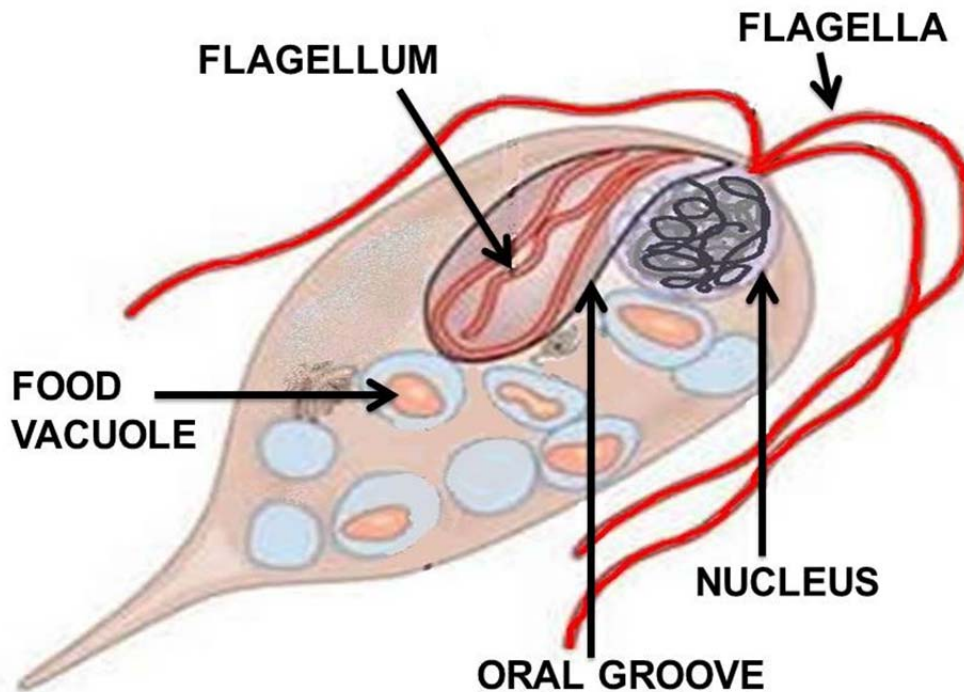

Giardia lamblia

Cryptosporidiosis

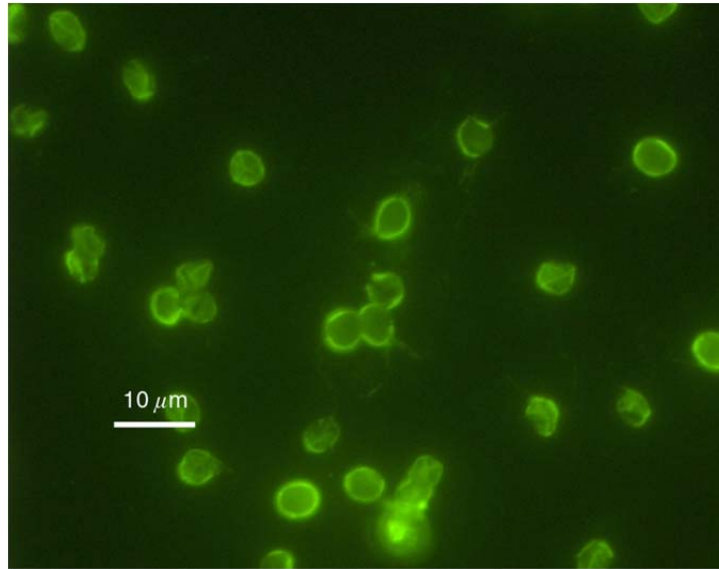

Cryptosporidiosis is an example of a protozoan disease that is common worldwide, but was only recently recognized as causing human disease. The major symptom in humans is diarrhea, which may be profuse and watery.

The diarrhea is associated with cramping abdominal pain. General malaise, fever, anorexia, nausea, and vomiting occur less often. Symptoms usually come and go, and end in fewer than 30 days in most cases. The incubation period is 1-12 days, with an average of about seven days. *Cryptosporidium* organisms have been identified in human fecal specimens from more than 50 countries on six continents.

The mode of transmission is fecal-oral, either by person-to-person or animal-to-person. There is no specific treatment for *Cryptosporidium* infections. All these diseases, with the exception of hepatitis A, have one symptom in common: diarrhea. They also have the same mode of transmission, fecal-oral, whether through person-to-person or animal-to-person contact, and the same routes of transmission, being either foodborne or waterborne.

Although most pathogens cause mild, self-limiting disease, on occasion, they can cause serious, even life threatening illness. Particularly vulnerable are persons with weak immune systems, such as those with HIV infections or cancer.

By understanding the nature of waterborne diseases, the importance of properly constructed, operated and maintained public water systems becomes obvious. While water treatment cannot achieve sterile water (no microorganisms), the goal of treatment must clearly be to produce drinking water that is as pathogen-free as possible at all times.

For those who operate water systems with inadequate source protection or treatment facilities, the potential risk of a waterborne disease outbreak is real. For those operating systems that currently provide adequate source protection and treatment, operating and maintaining the system at a high level on a continuing basis is critical to prevent disease.

Waterborne Diseases

Name	Causative organism	Source of organism	Disease
Viral gastroenteritis	Rotavirus (mostly in young children)	Human feces	Diarrhea or vomiting
Norwalk Agent	Noroviruses (genus <i>Norovirus</i> , family <i>Caliciviridae</i>) *1	Human feces; also, shellfish; lives in polluted waters	Diarrhea and vomiting
Salmonellosis	Salmonella (bacterium)	Animal or human feces	Diarrhea or vomiting
Gastroenteritis <i>Escherichia coli</i>	-- <i>E. coli</i> O157:H7 (bacterium): Other <i>E. coli</i> organisms:	Human feces	Symptoms vary with type caused
Typhoid	Salmonella typhi (bacterium)	Human feces, urine	Inflamed intestine, enlarged spleen, high temperature—sometimes fatal
Shigellosis	Shigella (bacterium)	Human feces	Diarrhea
Cholera	Vibrio choleras (bacterium)	Human feces; also, shellfish; lives in many coastal waters	Vomiting, severe diarrhea, rapid dehydration, mineral loss—high mortality
Hepatitis A	Hepatitis A virus	Human feces; shellfish grown in polluted waters	Yellowed skin, enlarged liver, fever, vomiting, weight loss, abdominal pain—low mortality, lasts up to four months
Amebiasis	Entamoeba histolytica (protozoan)	Human feces	Mild diarrhea, dysentery, extra intestinal infection
Giardiasis	Giardia lamblia (protozoan)	Animal or human feces	Diarrhea, cramps, nausea, and general weakness — lasts one week to months
Cryptosporidiosis	Cryptosporidium parvum	Animal or human feces	Diarrhea, stomach pain — lasts (protozoan) days to weeks

Notes:

*1 <http://www.cdc.gov/ncidod/dvrd/revb/gastro/norovirus.htm>

<http://www.cdc.gov/mmwr/preview/mmwrhtml/rr5009a1.htm>

General Contaminant Information

The sources of drinking water include rivers, lakes, streams, ponds, reservoirs, springs, and wells. As water travels over the surface of the land or through the ground, it dissolves naturally occurring minerals and in some cases, radioactive material, and can pick up substances resulting from the presence of animals or human activity.

Contaminants that may be present in sources of drinking water include:

Microbial contaminants, such as viruses and bacteria, which may come from sewage treatment plants, septic systems, agricultural livestock operations and wildlife;

Inorganic contaminants, such as salts and metals, which can be naturally occurring or result from urban stormwater runoff, industrial or domestic wastewater discharges, oil and gas production, mining or farming;

Pesticides and herbicides, which may come from a variety of sources such as agriculture, urban stormwater run-off, and residential uses;

Organic chemical contaminants, including synthetic and volatile organic chemicals, which are by-products of industrial processes and petroleum production, and can also come from gas stations, urban stormwater run-off, and septic systems;

Radioactive contaminants, which can be naturally occurring or be the result of oil and gas production and mining activities.

Background

Coliform bacteria and chlorine residual are the only routine sampling and monitoring requirements for small ground water systems with chlorination. The coliform bacteriological sampling is governed by the Total Coliform Rule (**TCR**) of the SDWA. Although there is presently no requirement for chlorination of groundwater systems under the SDWA, State regulations require chlorine residual monitoring of those systems that do chlorinate the water.

TCR The TCR requires all Public Water Systems (**PWS**) to monitor their distribution system for coliform bacteria according to the written sample sitting plan for that system. The sample sitting plan identifies sampling frequency and locations throughout the distribution system that are selected to be representative of conditions in the entire system. Coliform contamination can occur anywhere in the system, possibly due to problems such as; low pressure conditions, line breaks, or well contamination, and therefore routine monitoring is required. A copy of the sample sitting plan for the system should be kept on file and accessible to all who are involved in the sampling for the water system.

Number of Monthly Samples

The number of samples to be collected monthly depends on the size of the system. The TCR specifies the minimum number of coliform samples collected, but it may be necessary to take more than the minimum number in order to provide adequate monitoring.

This is especially true if the system consists of multiple sources, pressure zones, booster pumps, long transmission lines, or extensive distribution system piping. Since timely detection of coliform contamination is the purpose of the sample sitting plan, sample sites should be selected to represent the varying conditions that exist in the distribution system. The sample sitting plan should be updated as changes are made in the water system, especially the distribution system.

Sampling Procedures

The sample sitting plan must be followed and all operating staff must be clear on how to follow the sampling plan. In order to properly implement the sample sitting plan, staff must be aware of how often sampling must be done, the proper procedures and sampling containers to be used for collecting the samples, and the proper procedures for identification, storage and transport of the samples to an approved laboratory.

In addition, proper procedures must be followed for repeat sampling whenever a routine sample result is positive for total coliform. The following diagram outlines the requirements for responding to a positive Total Coliform sample.

Troubleshooting Table for Sampling Monitoring

Problem

1. Positive Total Coliform.
2. Chlorine taste and odor.
3. Inability to maintain an adequate free chlorine residual at the furthest points of the distribution system or at dead end lines.

Possible Causes

- 1A. Improper sampling technique.
- 1B. Contamination entering distribution system.
- 1C. Inadequate chlorine residual at the sampling site.
- 1D. Growth of **biofilm** in the distribution system.
- 2A. High total chlorine residual and low free residual.
- 3A. Inadequate chlorine dose at treatment plant.
- 3B. Problems with chlorine feed equipment.
- 3C. Ineffective distribution system flushing program.
- 3D. Growth of biofilm in the distribution system.

Possible Solutions

- 1A/ Check distribution system for low pressure conditions, possibly due to line breaks or excessive flows that may result in a backflow problem.
- 1B. Insure that all staff are properly trained in sampling and transport procedures as described in the TCR.
- 1C. Check the operation of the chlorination feed system. Refer to issues described in the sections on pumps and hypochlorination systems. Insure that residual test is being performed properly.
- 1D. Thoroughly flush effected areas of the distribution system. **Superchlorination** may be necessary in severe cases.
- 2A. The free residual should be at least 85% of the total residual. Increase the chlorine dose rate to get past the breakpoint in order to destroy some of the combined residual that causes taste and odor problems. Additional system flushing may also be required.
- 3A. Increase chlorine feed rate at point of application.
- 3B. Check operation of chlorination equipment.
- 3C. Review distribution system flushing program and implement improvements to address areas of inadequate chlorine residual.
- 3D. Increase flushing in area of biofilm problem.

General Contaminant Information

The sources of drinking water include rivers, lakes, streams, ponds, reservoirs, springs, and wells. As water travels over the surface of the land or through the ground, it dissolves naturally occurring minerals and in some cases, radioactive material, and can pick up substances resulting from the presence of animals or human activity.

Contaminants that may be present in sources of drinking water include:

Microbial contaminants, such as viruses and bacteria, which may come from sewage treatment plants, septic systems, agricultural livestock operations and wildlife; Inorganic contaminants, such as salts and metals, which can be naturally occurring or result from urban stormwater runoff, industrial or domestic wastewater discharges, oil and gas production, mining or farming; Pesticides and herbicides, which may come from a variety of sources such as agriculture, urban stormwater run-off and residential uses; Organic chemical contaminants, including synthetic and volatile organic chemicals, which are by-products of industrial processes and petroleum production, and can also come from gas stations, urban stormwater run-off and septic systems; Radioactive contaminants, which can be naturally occurring or be the result of oil and gas production and mining activities.

Background

Coliform bacteria and chlorine residual are the only routine sampling and monitoring requirements for small ground water systems with chlorination. The coliform bacteriological sampling is governed by the Total Coliform Rule (TCR) of the SDWA. Although there is presently no requirement for chlorination of groundwater systems under the SDWA, State regulations require chlorine residual monitoring of those systems that do chlorinate the water.

TCR The TCR requires all Public Water Systems (PWS) to monitor their distribution system for coliform bacteria according to the written sample siting plan for that system. The sample siting plan identifies sampling frequency and locations throughout the distribution system that are selected to be representative of conditions in the entire system. Coliform contamination can occur anywhere in the system, possibly due to problems such as; low pressure conditions, line breaks, or well contamination, and therefore routine monitoring is required. A copy of the sample siting plan for the system should be kept on file and accessible to all who are involved in the sampling for the water system.

Number of Monthly Samples The number of samples to be collected monthly depends on the size of the system. The TCR specifies the minimum number of coliform samples collected but it may be necessary to take more than the minimum number in order to provide adequate monitoring. This is especially true if the system consists of multiple sources, pressure zones, booster pumps, long transmission lines, or extensive distribution system piping. Since timely detection of coliform contamination is the purpose of the sample siting plan, sample sites should be selected to represent the varying conditions that exist in the distribution system. The sample siting plan should be updated as changes are made in the water system, especially the distribution system.

Sampling Procedures The sample siting plan must be followed and all operating staff must be clear on how to follow the sampling plan. In order to properly implement the sample siting plan, staff must be aware of how often sampling must be done, the proper procedures and sampling containers to be used for collecting the samples, and the proper procedures for identification, storage and transport of the samples to an approved laboratory. In addition, proper procedures must be followed for repeat sampling whenever a routine sample result is positive for total coliform. The following diagram outlines the requirements for responding to a positive Total Coliform sample.



There is nothing in the lab that is difficult to understand or eventually master. All of you should be able to learn and master the basic lab procedures. Don't be intimidated, learn to take samples and learn all you can about the lab, it is an excellent career. Bottom, normal sampling supplies.



Chain of Custody Procedures

Because a sample is physical evidence, chain of custody procedures are used to maintain and document sample possession from the time the sample is collected until it is introduced as evidence. Chain of custody requirements will vary from agency to agency.

However, these procedures are similar and the chain of custody outlined in this manual is only a guideline. Consult your project manager for specific requirements.

If you have physical possession of a sample, have it in view, or have physically secured it to prevent tampering then it is defined as being in **“custody.”** A chain of custody record, therefore, begins when the sample containers are obtained from the laboratory. From this point on, a chain of custody record will accompany the sample containers.

Handle the samples as little as possible in the field. Each custody sample requires a chain of custody record and may require a seal. If you do not seal individual samples, then seal the containers in which the samples are shipped.

When the samples transfer possession, both parties involved in the transfer must sign, date and note the time on the chain of custody record. If a shipper refuses to sign the chain-of-custody you must seal the samples and chain of custody documents inside a box or cooler with bottle seals or evidence tape. The recipient will then attach the shipping invoices showing the transfer dates and times to the custody sheets. If the samples are split and sent to more than one laboratory, prepare a separate chain of custody record for each sample. If the samples are delivered to after-hours night drop-off boxes, the custody record should note such a transfer and be locked with the sealed samples inside sealed boxes.



Using alcohol to disinfect a special sample tap before obtaining a sample.

LAB I.D. NUMBER																							
Laboratory 123 W. Main St Sun City, Arizona 85541																							
DATE: _____ PAGE 1 OF 1																							
Sampler: _____																							
Company: _____ Department: _____ Address: _____ Contact: _____ Telephone: _____																							
Sample Identification	Date	Time	Matrix	Lab ID	Metals* See Attached	TSS	Lead/Copper	BOD/COD	Nitrate	Nitrate + Nitrite	TKN / Amonia	VOC / THM's	Semi Volital Organics (625)	Chloride	Cyanide	Floride	Surfactants (MBAS)	Tot. Coliform MPN	Fecal Coliform MPN-HPC	Organo-Phosphorus Pest. (8141)	Sulfate	EC Conductivity	Number/Containers
Sample Receipt																							
Project Name					No. Containers: _____ Custody Seals: _____ Received Intact: _____ Received Cold: _____ Temperature: _____ PRIORITY: _____																		
Project Number					Yes No Yes No																		
Field Measurements:					pH: _____ Temp: _____																		
RELINQUISHED BY:					Signature: _____ Time: _____ Printed Name: _____ Date: _____ Company: _____																		
SAMPLED RECEIVED BY:					Signature: _____ Time: _____ Printed Name: _____ Date: _____ Company: _____																		

Chain of Custody Example.



Various water sample bottles and chain-of-custody form.



Carefully follow these steps when collecting a coliform sample:

1. Select the sampling site, which must be a faucet from which water is commonly taken for consumer use or a dedicated site in the distribution system.
 - a. The sampling point should be a non-swivel faucet.
 - b. If it is a faucet with an aerator, remove the aerator, screen and gasket and flush thoroughly.
 - c. If an outside faucet is used, disconnect any hoses or other attachments and flush the line thoroughly.
 - d. It should be a faucet that does not leak around the packing or valve mechanism. Leaking faucets can promote bacterial growth.
 - e. Do not use fire hydrants or drinking fountains as sampling points.
 - f. Do not dip sample bottles in reservoirs, spring boxes or storage tanks in order to collect a sample. If you have any questions about proper sampling sites, please contact your laboratory, environmental or health department or the state drinking water section.

2. Use only sample bottles provided by the laboratory specifically for bacteriological sampling.

These bottles are sterile and should not be rinsed before sampling. A chemical, usually sodium thiosulfate, is placed in the bottle by the lab and is used for chlorine deactivation. Do not remove it.

3. Don't open the sample bottle until the moment you are going to fill it.

4. Flush the line thoroughly. Run water through the faucet for three to five minutes before opening the bottle and collecting the sample.

5. Uncap the sample bottle, being careful not to touch the inside of the bottle with your fingers or other objects. Do not set the lid down while taking the sample.

6. Reduce the water flow to a slow steady stream. Continue flushing for at least 1-2 minutes, then gently fill the sample bottle to the fill mark. At least 100 ml. of water is necessary for analysis. Leave an air space in the top of the bottle. Do not overfill.

7. Replace the cap immediately, making sure it is tight and does not leak.

8. Label the laboratory form. Complete the following information:

- a. Your Public Water System (PWS) ID number.
- b. Your water system name, address, city and phone number.
- c. Collection date and time.
- d. Type of sample: Routine, Repeat, and Special. Refer to previous discussion of definitions.
- e. Name of person collecting sample and sample location.
- f. Free chlorine residual if your system is chlorinated. The residual should be measured at the time of sample collection.
- g. Complete the section for the return address where the report is to be sent.

9. Package the sample for delivery to the laboratory.

Be sure to include the lab form. The sample should be kept cool if at all possible.

10. Mail or deliver the sample to the lab immediately. Samples over 30 hours old will not be analyzed by the laboratory. If the sample is too old or leaks in transit, the lab will notify you and you must collect another.



Sampling Plan Example

A written sampling plan must be developed by the water system. These plans will be reviewed by the Health Department or State Drinking Water agency during routine field visits for sanitary surveys or technical assistance visits. This plan should include:

1. The location of routine sampling sites on a system distribution map. You will need to locate more routine sampling sites than the number of samples required per month or quarter. A minimum of three sites is advised and the sites should be rotated on a regular basis.
2. Map the location of repeat sampling sites for the routine sampling sites. Remember that repeat samples must be collected within five (5) connections upstream and downstream from the routine sample sites.
3. Establish a sampling frequency of the routine sites.
4. Sampling technique, establish a minimum flushing time and requirements for free chlorine residuals at the sites (if you chlorinate continuously).

The sampling sites should be representative of the distribution network and pressure zones. If someone else, e.g., the lab, collects samples for you, you should provide them with a copy of your sampling plan and make sure they have access to all sample sites.



This fellow is taking a sample from a stream to check the water quality.

Collection of Surface Water Samples

Representative samples may be collected from rivers, streams and lakes if certain rules are followed:

1. Watch out for flash floods! If a flooding event is likely and samples must be obtained, always go in two-person teams for safety. Look for an easy route of escape.
2. Select a sampling location at or near a gauging station, so that stream discharge can be related to water-quality loading. If no gauging station exists, then measure the flow rate at the time of sampling, using the streamflow method described below.
3. Locate a straight and uniform channel for sampling.
4. Unless specified in the sampling plan, avoid sampling locations next to confluences or point sources of contamination.
5. Use bridges or boats for deep rivers and lakes where wading is dangerous or impractical.
6. Do not collect samples along a bank, as they may not be representative of the surface water body as a whole.
7. Use appropriate gloves when collecting the sample.

Streamflow Measurement

Before collecting water quality samples, record the stream's flow rate at the selected station. The flow rate measurement is important for estimating contaminant loading and other impacts.

The first step in streamflow measurement is selecting a cross-section. Select a straight reach where the stream bed is uniform and relatively free of boulders and aquatic growth. Be certain that the flow is uniform and free of eddies, slack water and excessive turbulence.

After the cross-section has been selected, determine the width of the stream by stringing a measuring tape from bank-to-bank at right angles to the direction of flow. Next, determine the spacing of the verticals. Space the verticals so that no partial section has more than 5 per cent of the total discharge within it.

At the first vertical, face upstream and lower the velocity meter to the channel bottom, record its depth, then raise the meter to 0.8 and 0.2 of the distance from the stream surface, measure the water velocities at each level, and average them. Move to the next vertical and repeat the procedure until you reach the opposite bank. Once the velocity, depth and distance of the cross-section have been determined, the mid-section method can be used for determining discharge. Calculate the discharge in each increment by multiplying the averaged velocity in each increment by the increment width and averaged depth.

(Note that the first and last stations are located at the edge of the waterway and have a depth and velocity of zero.) Add up the discharges for each increment to calculate total stream discharge. Record the flow in liters (or cubic feet) per second in your field book.

Composite Sampling

Composite sampling is intended to produce a water quality sample representative of the total stream discharge at the sampling station. If your sampling plan calls for composite sampling, use an automatic type sampler.

Chemical Monitoring

The final federal rules regarding Phase II and V contaminants were promulgated by the U.S. EPA in 1992 and initial monitoring began in January 1993. This group of contaminants consists of Inorganic Chemicals (**IOC**), Volatile Organic Chemicals (**VOC**) and Synthetic Organic Chemicals (**SOC**) and the rule applies to all community and non-transient non-community public water systems.

The monitoring schedule for these contaminants is phased in by water system population size according to a “**standardized monitoring framework**” established by the U.S. EPA. This standardized monitoring framework establishes nine-year compliance cycles consisting of three 3-year compliance periods. The first compliance cycle began in January 1993 and ended December 31, 2001, with subsequent compliance cycles following the nine-year timeframe. The three-year compliance period of each cycle is the standard monitoring period for the water system.

Turbidity Monitoring

Monitoring for turbidity is applicable to all public water systems using surface water sources or ground water sources under the direct influence of surface water in whole or part. Check with your state drinking water section or health department for further instructions.

The maximum contaminant level for turbidity for systems that provide filtration treatment:

1. Conventional or direct filtration: less than or equal to 0.5 NTU in at least 95% of the measurements taken each month. Conventional filtration treatment plants should be able to achieve a level of 0.1 NTU with proper chemical addition and operation.
2. Slow sand filtration, cartridge and alternative filtration: less than or equal to 1 NTU in at least 95% of the measurements taken each month. The turbidity levels must not exceed 5 NTU at any turbidity measurements must be performed on representative samples of the filtered water every four (4) hours that the system serves water to the public. A water system may substitute continuous turbidity monitoring for grab sample monitoring if it validates the continuous measurement for accuracy on a regular basis using a protocol approved by the Health or Drinking Water Agency, such as confirmation by a bench top turbidimeter. For systems using slow sand filtration, cartridge, or alternative filtration treatment the Health or Drinking Water Agency may reduce the sampling frequency to once per day if it determines that less frequent monitoring is sufficient to indicate effective filtration performance.

Inorganic Chemical Monitoring

All systems must monitor for inorganics. The monitoring for these contaminants is also complex with reductions, waivers and detections affecting the sampling frequency. Please refer to the monitoring schedules provided by your state health or drinking water sections for assistance in determining individual requirements. All transient non-community water systems are required to complete a one-time inorganic chemical analysis. The sample is to be collected at entry points (**POE**) to the distribution system representative of each source after any application of treatment.



Nitrates

Nitrate is an inorganic chemical that occurs naturally in some groundwater but most often is introduced into ground and surface waters by man. The most common sources are from fertilizers and treated sewage or septic systems.

At high levels (over 10 mg/l) it can cause the “**blue baby**” syndrome in young infants, which can lead to serious illness and even death. It is regarded as an “**acute health risk**” because it can quickly cause illness.

Every water system must test for **Nitrate** at least yearly. Systems that use ground water only must test yearly. Systems that use surface water and those that mix surface and ground water must test every quarter. A surface water system may go to yearly testing if community and nontransient noncommunity water must do quarterly monitoring whenever they exceed 5 mg/l in a test. After 4 quarters of testing and the results show that the nitrate level is not going up, they may go back to yearly testing.

Radiological Contaminants

All community water systems shall monitor for gross alpha activity every four years for each source. Depending on your state rules, compliance will be based on the annual composite of 4 consecutive quarters or the average of the analyses of 4 quarterly samples. If the average annual concentration is less than one half the MCL, an analysis of a single sample may be substituted for the quarterly sampling procedure.

Total Trihalomethanes (TTHM)

All community water systems serving a population of 10,000 or more and which add a disinfectant in any part of the drinking water treatment process shall monitor for total trihalomethanes (**TTHM**). The MCL is 0.1 mg/l and consists of a calculation of the running average of quarterly analyses of the sum of the concentrations of bromodichloromethane, di-bromochloromethane, bromoform and chloroform.

Lead and Copper Rule

The Lead and Copper Rule was promulgated by the U.S. EPA on June 7, 1991, with monitoring to begin in January 1992 for larger water systems. This rule applies to all community and nontransient, noncommunity water systems and establishes action levels for these two contaminants at the consumer’s tap. Action levels of 0.015 mg/l for lead and 1.3 mg/l for copper have been established.

This rule establishes maximum contaminant level goals (**MCLGs**) for lead and copper, treatment technique requirements for optimal corrosion control, source water treatment, public education and lead service line replacement. Whenever an action level is exceeded, the corrosion control treatment requirement is triggered. This is determined by the concentration measured in the 90th percentile highest sample from the samples collected at consumers’ taps. Sample results are assembled in ascending order (lowest to highest) with the result at the 90th percentile being the action level for the system. For example, if a water system collected 20 samples, the result of the 18th highest sample would be the action level for the system.

The rule also includes the best available technology (**BAT**) for complying with the treatment technique requirements, mandatory health effects language for public notification of violations and analytical methods and laboratory performance requirements.

Initial monitoring began in January 1992 for systems with a population of 50,000 or more, in July 1992 for medium-sized systems (3,300 to 50,000 population) and in July 1993 for small-sized systems (less than 3,300 population),

One-liter tap water samples are to be collected at high-risk locations by either water system personnel or residents. Generally, high-risk locations are homes with lead-based solder installed after 1982 or with lead pipes or service lines. If not enough of these locations exist in the water system, the rule provides specific guidelines for selecting other sample sites.

The water must be allowed to stand motionless in the plumbing pipes for at least six (6) hours and collected from a cold water tap in the kitchen or bathroom. It is a first draw sample, which means the line is not to be flushed prior to sample collection. The number of sampling sites is determined by the population of the system and sample collection consists of two, six-month monitoring periods; check with your state rule or drinking water section for more information.

Sampling Sites by Population

System size - No. of sites - No. of sites (no. of persons served) (standard monitoring) (reduced monitoring)		
>100,000	100	50
10,001-100,000	60	30
3,301 to 10,000	40	20
501 to 3,300	20	10
101 to 500	10	5
< 100	5	5

If a system meets the lead and copper action levels or maintains optimal corrosion control treatment for two consecutive six-month monitoring periods, then reduced monitoring is allowed and sampling frequency drops to once per year. After three consecutive years of reduced monitoring, sample frequency drops to once every three years. In addition to lead and copper testing, all large water systems and those medium- and small-sized systems that exceed the lead or copper action levels will be required to monitor for the following water quality parameters: pH, alkalinity, calcium, conductivity, orthophosphate, silica and water temperature.

These parameters are used to identify optimal corrosion control treatment and determine compliance with the rule once treatment is installed. The sampling locations for monitoring water quality parameters are at entry points and representative taps throughout the distribution system.

Coliform sampling sites can be used for distribution system sampling. The number of sites required for monitoring water quality during each six-month period is shown below.

Number of Water Quality Parameters per Population

System size # of sites for water (no. of persons served) quality parameters	
>100,000	25
10,001-100,000	10
3,301 to 10,000	3
501 to 3,300	2
101 to 500	1
<100	1

Water systems which maintain water quality parameters reflecting optimal corrosion control for two consecutive six-month monitoring periods qualify for reduced monitoring. After three consecutive years, the monitoring frequency can drop to once per year.

All large water systems must demonstrate that their water is minimally corrosive or install corrosion control treatment regardless of lead and copper sampling results.

QA/QC Measures

In addition to standard samples, the field technicians collect equipment blanks (**EB**), field cleaned equipment blanks (**FB**), split samples (**SS**), and field duplicate samples (**FD**).

Overall care must be taken in regards to equipment handling, container handling/storage, decontamination, and record keeping. Sample collection equipment and non-preserved sample containers must be rinsed three times with sample water before the actual sample is taken. Exceptions to this are any pre-preserved container or bac-t type samples.

If protective gloves are used, they shall be clean, new and disposable. These should be changed upon arrival at a new sampling point. Highly contaminated samples shall never be placed in the same ice chest as environmental samples. It is good practice to enclose highly contaminated samples in a plastic bag before placing them in ice chests. The same is true for wastewater and drinking water samples.

Ice chests or shipping containers with samples suspected of being highly contaminated shall be lined with new, clean, plastic bags. If possible, one member of the field team should take all the notes, fill out labels, etc., while the other member does all of the sampling.

Preservation of Samples

Proper sample preservation is the responsibility of the sampling team, not the lab providing sample containers. The best reference for preservatives is Standard Methods or your local laboratory.

It is the responsibility of the field team to assure that all samples are appropriately preserved.

Follow the preservative solution preparation instructions.

Always use strong safety precautions diluting the acid.

Put a new label on the dispensing bottle with the current date.

Slowly add the acid or other preservative to the water sample; not water to the acid or preservative.



Wait 3-4 hours for the preservative to cool most samples down to 4 degrees Celsius.

Most preservatives have a shelf life of one year from the preparation date.

When samples are analyzed for TKN, TP, NH₄ and NO_x 1 mL of 50% Trace Metal grade sulfuric acid is added to the each discrete auto sampler bottles/bags in the field lab before sampling collection. The preservative maintains the sample at 1.5<pH<2 after collection. To meet maximum holding time for these preserved samples (28 days), pull and ship samples every 14 days.

Narrow range pH paper (test strips) can be used to test an aliquot of the preserved sample.

Place the pH paper into the container and compare the color with the manufacturer's color chart.

Water Disinfectant Terminology

Many water suppliers add a disinfectant to drinking water to kill germs such as giardia and e coli. Especially after heavy rainstorms, your water system may add more disinfectant to guarantee that these germs are killed.

Chlorine. Some people who use drinking water containing chlorine well in excess of the EPA standard could experience irritating effects to their eyes and nose. Some people who drink water containing chlorine well in excess of the EPA standard could experience stomach discomfort.

Chloramine. Some people who use drinking water containing chloramines well in excess of the EPA standard could experience irritating effects to their eyes and nose. Some people who drink water containing chloramines well in excess of the EPA standard could experience stomach discomfort or anemia.

Chlorine Dioxide. Some infants and young children who drink water containing chlorine dioxide in excess of the EPA standard could experience nervous system effects. Similar effects may occur in fetuses of pregnant women who drink water containing chlorine dioxide in excess of the EPA standard. Some people may experience anemia.

Disinfection Byproducts

Disinfection byproducts form when disinfectants added to drinking water to kill germs react with naturally-occurring organic matter in water.

Total Trihalomethanes. Some people who drink water containing trihalomethanes in excess of the EPA standard over many years may experience problems with their liver, kidneys, or central nervous systems, and may have an increased risk of getting cancer.

Haloacetic Acids. Some people who drink water containing haloacetic acids in excess of the EPA standard over many years may have an increased risk of getting cancer.

Bromate. Some people who drink water containing bromate in excess of the EPA standard over many years may have an increased risk of getting cancer.

Chlorite. Some infants and young children who drink water containing chlorite in excess of EPA standard could experience nervous system effects. Similar effects may occur in fetuses of pregnant women who drink water containing chlorite in excess of the EPA's standard. Some people may experience anemia.

MTBE is a fuel additive, commonly used in the United States to reduce carbon monoxide and ozone levels caused by auto emissions. Due to its widespread use, reports of MTBE detections in the nation's ground and surface water supplies are increasing. The Office of Water and other EPA offices are working with a panel of leading experts to focus on issues posed by the continued use of MTBE and other oxygenates in gasoline. The EPA is currently studying the implications of setting a drinking water standard for MTBE.

Health advisories provide additional information on certain contaminants. Health advisories are guidance values based on health effects other than cancer. These values are set for different durations of exposure (e.g., one-day, ten-day, longer-term, and lifetime).



Modern water quality or sampling truck set-up. Various tools, rope, hammers are nice to have but not always necessary. I like that this sampler wears a reflective vest and gloves, I think he is safety conscience.



Examples of Water Sampling Letters and Forms

January 13, 2015

Wyatt Curtiss
1718 West Van Buren Street
Sunflower, AZ 85007

Dear Mr. Curtiss:

The City of Sunflower initially responded to your water quality concerns on May 19, 2015. We found insufficient chlorine in the drinking water at your business. We proceeded to flush and redirect the water in your area.

We resampled your area on two additional dates:

Address	May 28, 2011		July 25, 2011	
	Chlorine (mg/L)	CFU	Chlorine (mg/L)	CFU
310 N. 17th Professor	0.3	780	0.8	<1
1708 W. Van Buren St.	0.2	305	0.6	8

Currently our results indicate good conditions in your area. According to our testing method, a CFU (Colony Forming Units) count of bacteria below 500 is considered adequately disinfected (passing). Other evidence of good water quality is the absence of Total Coliform and the *Escherichia coli* bacteria. This is indicated by the "-" (negative) results in the "Total Coliform" and the "E. Coli" columns of the Bacteriological Analysis Form.

Quality control is documented on the bottom of the Bacteriological Analysis Form. The results are normal and indicate that the incubator was kept at the correct temperature and that we were looking for the correct organisms.

All tests indicate that the drinking water being provided is safe. Should you have any questions regarding drinking water quality in the City of Sunflower, please contact me at 474-8888. Our office hours are 8:00 a.m. to 5:00 p.m., Monday through Friday.

Sincerely,

Bill Fields
Water Quality Inspector

<DATE>

<NAME>

<ADDRESS>

Dear <NAME>:

Thank you for collecting drinking water samples from your home for the City of Sunflower's Lead and Copper monitoring program. You will be receiving the test results soon -- if you haven't received them already.

Our tests show there is essentially no lead or copper in water coming to you from our water treatment plants. But we also need to know if our drinking water leaches lead or copper from your household plumbing. The only way we can learn this information is to analyze samples from inside your home.

Thanks again for your help. With the information we gain we can do an even better job of making sure your tap water meets all federal and state health and safety regulations.

Sincerely,

Chris Mitchell
Mayor

June 11, 2019

Mr. Doc Curtiss
1008 East Northern Avenue
Sunflower, Arizona 85020

Dear Mr. Curtiss:

The City of Sunflower responded to your water quality concerns on 11/27/19. We collected a bacteriological sample and checked the chlorine level at your home. The results are recorded on our worksheet, the Bacteriological Analysis Form, and are attached to this letter.

Our results indicate excellent conditions with 10 Colony Forming Units (CFU) per site. According to our testing method, a CFU count below 500 is considered adequately disinfected (passing). Other evidence of good water quality is the absence of Total Coliform and the Escherichia Coli bacteria. This is indicated by the "-" (negative) results in the Total Coliform and the E. Coli columns of the Bacteriological Analysis Form.

Quality control is documented on the bottom of the Bacteriological Analysis Form. The results are normal and indicate that the incubator was kept at the correct temperature and that we were looking for the correct organisms.

The chlorine level was checked at the same sampling site. The chlorine level was adequate with a reading of 0.7 mg/L.

All tests indicate that the drinking water being provided is safe. Should you have any questions, please contact me at 232-9508. Our office hours are 8:00 a.m. to 5:00 p.m., Monday through Friday.

Sincerely,

Bill Fields
Water Quality Inspector

Facts About Water Taste and Odor *Customer Letter Example*

Musty or earthy odors are something common to water systems that use surface water (rivers, streams and lakes) as a source of their drinking water. These odors are natural and are usually the result of algae growth. The growth is most common when air and water temperatures begin to drop in the fall as a result of changes in the weather. A certain temperature range makes algae grow more quickly in the surface water. The odor may occur intermittently through January.

Some people find the odor objectionable and/or a nuisance, but it represents no health hazard. The odor affects only the aesthetic quality of the water.

The Water Services Department treats water at treatment plants to ensure it meets all health and safety standards. We add chlorine to the water to protect against harmful organisms. The department regularly tests the drinking water for about 150 different compounds.

If you experience a musty odor in the water you drink, try the following:

- First, fill a water bottle and leave it uncapped on the counter for 30 to 60 minutes.
- Then, refrigerate the water for a few hours.
- If there still is some odor, try running the tap for 15 to 30 seconds before filling the water jug.
- Finally, inexpensive carbon filters can be added at the faucet to help eliminate the odors. However, remember to follow directions concerning maintenance such as cleaning or replacing the filter.

During seasonal changes, our water often contains 10-15 parts per trillion of the natural compound that creates the musty odor. Some people can detect the odor when there is as little as five parts per trillion in the water. For purposes of comparison, five parts per trillion is comparable to five seconds in 32,000 years.

Remember, the odor is seasonal and is not a health hazard. It usually occurs in the fall and disappears sometime during the winter.

Troubleshooting Table for Sampling Monitoring

Problem

1. Positive Total Coliform.
2. Chlorine taste and odor.
3. Inability to maintain an adequately free chlorine residual at the furthest points of the distribution system or at dead end lines.

Possible Cause

- 1A. Improper sampling technique.
- 1B. Contamination entering distribution system.
- 1C. Inadequate chlorine residual at the sampling site.
- 1D. Growth of biofilm in the distribution system.
- 2A. High total chlorine residual and low free residual.
- 3A. Inadequate chlorine dose at treatment plant.
- 3B. Problems with chlorine feed equipment.
- 3C. Ineffective distribution system flushing program.
- 3D. Growth of biofilm in the distribution system.

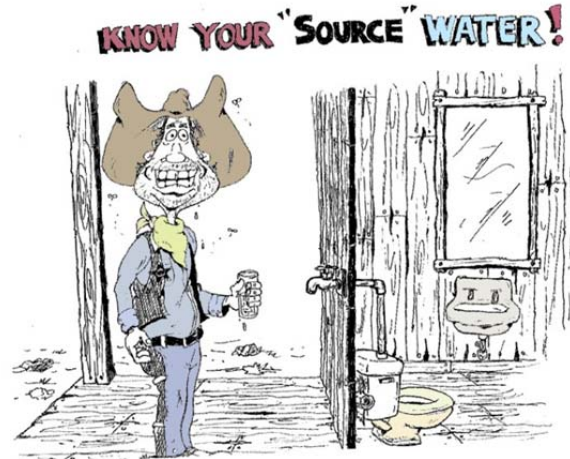

Possible Solution

- 1A/ Check distribution system for low pressure conditions, possibly due to line breaks or excessive flows that may result in a backflow problem.
- 1B. Insure that all staff are properly trained in sampling and transport procedures as described in the TCR.
- 1C. Check the operation of the chlorination feed system. Refer to issues described in the sections on pumps and hypochlorination systems. Insure that residual test is being performed properly.
- 1D. Thoroughly flush effected areas of the distribution system. Superchlorination may be necessary in severe cases.
- 2A. The free residual should be at least 85% of the total residual. Increase the chlorine dose rate to get past the breakpoint in order to destroy some of the combined residual that causes taste and odor problems. Additional system flushing may also be required.
- 3A. Increase chlorine feed rate at point of application.
- 3B. Check operation of chlorination equipment.
- 3C. Review distribution system flushing program and implement improvements to address areas of inadequate chlorine residual.
- 3D. Increase flushing in area of biofilm problem.



150-pound chlorine gas cylinder.

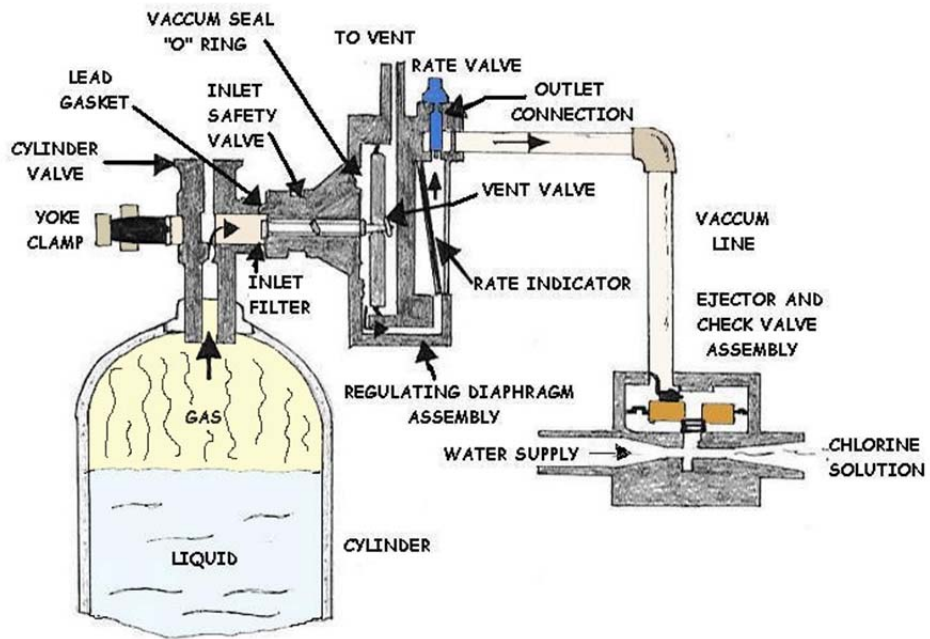

Chlorine Section Chapter 6



1-ton chlorine containers, rear side of container.



Professor Durbin in front of a Chlorine rotometer.



Hard to tell, but these are 1- ton chlorine gas containers. Notice the five gallon bucket of motor oil in the bottom photograph. Also notice that this photograph is the only eye wash station that we found during our inspection of 10 different facilities. Do you have an eye wash and emergency shower?



Chlorine Gas

Background

Chlorine gas is a pulmonary irritant with intermediate water solubility that causes acute damage in the upper and lower respiratory tract. Chlorine gas was first used as a chemical weapon at Ypres, France in 1915. Of the 70,552 American soldiers poisoned with various gasses in World War I, 1843 were exposed to chlorine gas. Approximately 10.5 million tons and over 1 million containers of chlorine are shipped in the U.S. each year.

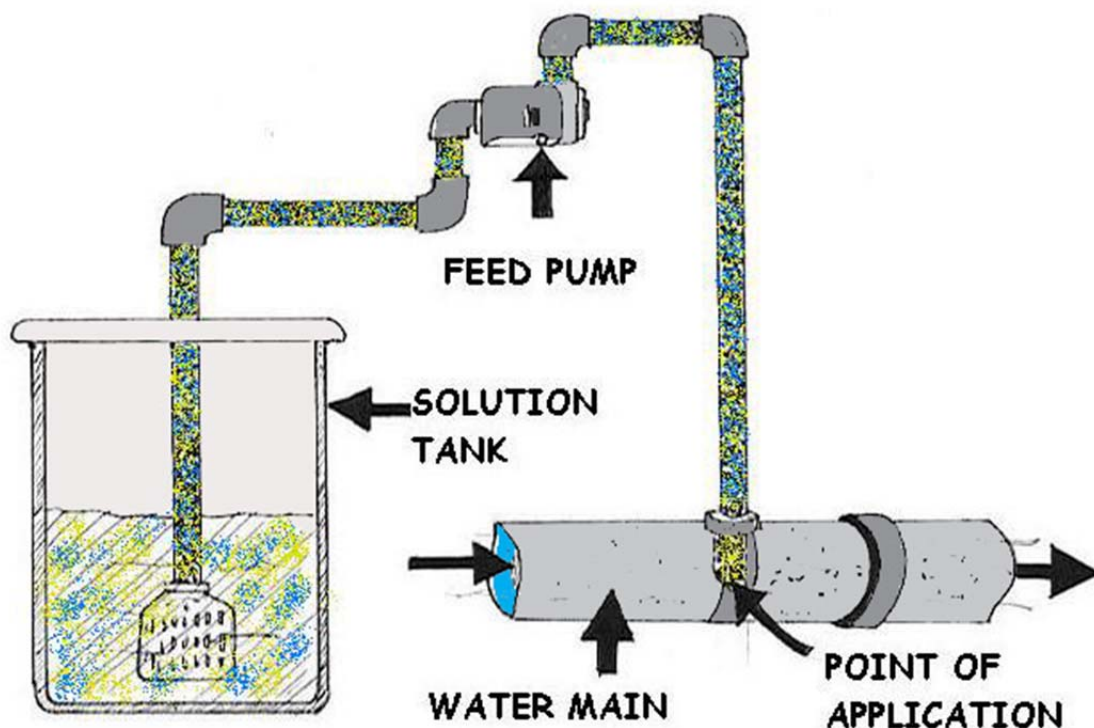

Chlorine is a yellowish-green gas at standard temperature and pressure. It is extremely reactive with most elements. Because its density is greater than that of air, the gas settles low to the ground. It is a respiratory irritant, and it burns the skin. Just a few breaths of it are fatal. Cl_2 gas does not occur naturally, although Chlorine can be found in a number of compounds.

Atomic Number: 17

Standard State: Gas at 298K

Melting Point: 171.6K (-101.5 C)

Boiling Point: 239.11K (-34.04 C)

Density: N/A

Molar Volume: 17.39 cm^3

Electronegativity: 3.16 Pauling Units

Crystal Structure: The Diatomic Chlorine molecules arrange themselves in an orthorhombic structure.

Pathophysiology

Chlorine is a greenish-yellow, noncombustible gas at room temperature and atmospheric pressure. The intermediate water solubility of chlorine accounts for its effect on the upper airway and the lower respiratory tract. Exposure to chlorine gas may be prolonged because its moderate water solubility may not cause upper airway symptoms for several minutes. In addition, the density of the gas is greater than that of air, causing it to remain near ground level and increasing exposure time.

The odor threshold for chlorine is approximately 0.3-0.5 parts per million (**ppm**); however, distinguishing toxic air levels from permissible air levels may be difficult until irritative symptoms are present.

Mechanism of Activity

The mechanisms of the above biological activity are poorly understood and the predominant anatomic site of injury may vary, depending on the chemical species produced. Cellular injury is believed to result from the oxidation of functional groups in cell components, from reactions with tissue water to form hypochlorous and hydrochloric acid, and from the generation of free oxygen radicals. Although the idea that chlorine causes direct tissue damage by generating free oxygen radicals was once accepted, this idea is now controversial.

The cylinders on the right contain chlorine gas. The gas comes out of the cylinder through a gas regulator. The cylinders are on a scale that operators use to measure the amount used each day. The chains are used to prevent the tanks from falling over.

Chlorine gas is stored in vented rooms that have panic bar equipped doors. Operators have the equipment necessary to reduce the impact of a gas leak, but rely on trained emergency response teams to contain leaks.

Solubility Effects

Hydrochloric acid is highly soluble in water. The predominant targets of the acid are the epithelia of the ocular conjunctivae and upper respiratory mucus membranes.

Hypochlorous acid is also highly water soluble with an injury pattern similar to hydrochloric acid.

Hypochlorous acid may account for the toxicity of elemental chlorine and hydrochloric acid to the human body.

Early Response to Chlorine Gas

Chlorine gas, when mixed with ammonia, reacts to form chloramine gas. In the presence of water, chloramines decompose to ammonia and hypochlorous acid or hydrochloric acid.

The early response to chlorine exposure depends on the (1) concentration of chlorine gas, (2) duration of exposure, (3) water content of the tissues exposed, and (4) individual susceptibility.



Immediate Effects

The immediate effects of chlorine gas toxicity include acute inflammation of the conjunctivae, nose, pharynx, larynx, trachea, and bronchi. Irritation of the airway mucosa leads to local edema secondary to active arterial and capillary hyperemia.

Plasma exudation results in filling the alveoli with edema fluid, resulting in pulmonary congestion.

Pathological Findings

Pathologic findings are nonspecific. They include severe pulmonary edema, pneumonia, hyaline membrane formation, multiple pulmonary thromboses, and ulcerative tracheo-bronchitis.

The hallmark of pulmonary injury associated with chlorine toxicity is pulmonary edema, manifested as hypoxia. Non-cardiogenic pulmonary edema is thought to occur when there is a loss of pulmonary capillary integrity.



1-ton chlorine gas containers.

Unbelievably, this facility uses between 20 and 30 containers per day. 3 shifts are required to handle the chlorine change outs each day. Normally this is a slow boring job if everything is working properly. This crew is also responsible for any and all chlorine leaks. Even when the fire crews show up for a Cl_2 leak, the fire crews are too scared to touch a leaking cylinder and will ask the water treatment personnel to fix the leak.

Chemical Equations, Oxidation States, and Balancing of Equations

Before we breakdown chlorine and other chemicals, let's start with this review of basic chemical equations.

Beginning

The common chemical equation could be $A + B \rightarrow C + D$. This is chemical A + chemical B, the two reacting chemicals will go to products C + D, etc.

Oxidation

The term "oxidation" originally meant a reaction in which oxygen combines chemically with another substance, but its usage has long been broadened to include any reaction in which electrons are transferred.

Oxidation and reduction always occur simultaneously (redox reactions), and the substance which gains electrons is termed the oxidizing agent. For example, cupric ion is the oxidizing agent in the reaction: $\text{Fe (metal)} + \text{Cu}^{++} \rightarrow \text{Fe}^{++} + \text{Cu (metal)}$; here, two electrons (negative charges) are transferred from the iron atom to the copper atom; thus the iron becomes positively charged (is oxidized) by loss of two electrons, while the copper receives the two electrons and becomes neutral (is reduced).

Electrons may also be displaced within the molecule without being completely transferred away from it. Such partial loss of electrons likewise constitutes oxidation in its broader sense and leads to the application of the term to a large number of processes, which at first sight might not be considered to be oxidation. Reaction of a hydrocarbon with a halogen, for example, $\text{CH}_4 + 2 \text{Cl} \rightarrow \text{CH}_3\text{Cl} + \text{HCl}$, involves partial oxidation of the methane; halogen addition to a double bond is regarded as an oxidation.

Dehydrogenation is also a form of oxidation; when two hydrogen atoms, each having one electron, are removed from a hydrogen-containing organic compound by a catalytic reaction with air or oxygen, as in oxidation of alcohol to aldehyde.

Oxidation Number

The number of electrons that must be added to or subtracted from an atom in a combined state to convert it to the elemental form; i.e., in barium chloride (BaCl_2) the oxidation number of barium is +2 and of chlorine is -1. Many elements can exist in more than one oxidation state.

Now, let us look at some common ions. An ion is the reactive state of the chemical, and is dependent on its place within the periodic table.

Have a look at the "periodic table of the elements". It is arranged in columns of elements, there are 18 columns. You can see column one, H, Li, Na, K, etc. These all become ions as H^+ , Li^+ , K^+ , etc. The next column, column 2, Be, Mg, Ca etc. become ions Be^{2+} , Mg^{2+} , Ca^{2+} , etc. Column 18, He, Ne, Ar, Kr are inert gases. Column 17, F, Cl, Br, I, ionize to a negative F^- , Cl^- , Br^- , I^- , etc.

What you now need to do is memorize the table of common ions, both positive ions and negative ions.

Table of Common Ions
Positive Ions

Valency 1		Valency 2		Valency 3	
lithium	Li ⁺	magnesium	Mg ²⁺	aluminum	Al ³⁺
sodium	Na ⁺	calcium	Ca ²⁺	iron III	Fe ³⁺
potassium	K ⁺	strontium	Sr ²⁺	chromium	Cr ³⁺
silver	Ag ⁺	barium	Ba ²⁺		
hydronium	H ₃ O ⁺	copper II	Cu ²⁺		
(or hydrogen)	H ⁺	lead II	Pb ²⁺		
ammonium	NH ₄ ⁺	zinc	Zn ²⁺		
copper I	Cu ⁺	manganese II	Mn ²⁺		
mercury I	Hg ⁺	iron II	Fe ²⁺		
		tin II	Sn ²⁺		

Negative Ions

Valency 1		Valency 2		Valency 3	
fluoride	F ⁻	oxide	O ²⁻	phosphate	PO ₄ ³⁻
chloride	Cl ⁻	sulfide	S ²⁻		
bromide	Br ⁻	carbonate	CO ₃ ²⁻		
iodide	I ⁻	sulfate	SO ₄ ²⁻		
hydroxide	OH ⁻	sulfite	SO ₃ ²⁻		
nitrate	NO ₃ ⁻	dichromate	Cr ₂ O ₇ ⁻		
bicarbonate	HCO ₃ ⁻	chromate	CrO ₄ ²⁻		
bisulphate	HSO ₄ ⁻	oxalate	C ₂ O ₄ ²⁻		
nitrite	NO ₂ ⁻	thiosulfate	S ₂ O ₃ ²⁻		
chlorate	ClO ₃ ⁻	tetrathionate	S ₄ O ₆ ²⁻		
permanganate	MnO ₄ ⁻	monohydrogen phosphate	HPO ₄ ²⁻		
hypochlorite	OCl ⁻				
dihydrogen phosphate	H ₂ PO ₄ ⁻				

Positive ions will react with negative ions, and vice versa. This is the start of our chemical reactions. For example:

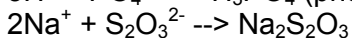
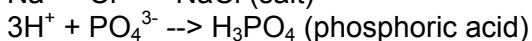
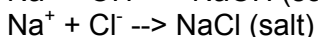
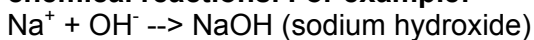

You will see from these examples, that if an ion of one (+), reacts with an ion of one (-) then the equation is balanced. However, an ion like PO_4^{3-} (phosphate) will require an ion of 3+ or an ion of one (+) (but needs three of these) to neutralize the 3- charge on the phosphate. So, what you are doing is balancing the charges (+) or (-) to make them zero, or cancel each other out.

For example, since aluminum exists in its ionic state as Al^{3+} , it will react with many negatively charged ions; for example: Cl^- , OH^- , SO_4^{2-} , PO_4^{3-} .

Let us do these examples and balance them.

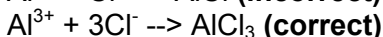

How did we work this out?

Al^{3+} has three positives (3+)

Cl^- has one negative (-)

It will require **3 negative charges** to cancel out the **3 positive charges** on the aluminum (Al^{3+}).

When the **left hand side** of the equation is written, to balance the number of chlorine's (Cl^-) required, the number 3 is placed in front of the ion concerned, in this case Cl^- , becomes 3Cl^- .

On the **right hand side** of the equation, where the ions have become a compound (a chemical compound), the number is transferred to after the relevant ion, Cl_3 .

Another example:



Let me give you an easy way of balancing:

Al is 3+

SO_4 is 2-

Simply transpose the number of positives (or negatives) for each ion, to the other ion, by placing this value of one ion, in front of the other ion. That is, Al^{3+} the 3 goes in front of the SO_4^{2-} as 3SO_4^{2-} , and SO_4^{2-} , the 2 goes in front of the Al^{3+} to become 2Al^{3+} . Then on the **right hand side** of the equation, this same number (now in front of each ion on the **left side** of the equation), is placed after each "ion" entity.

Let us again look at:



Put the three from the Al in front of the SO_4^{2-} and the 2 from the SO_4^{2-} in front of the Al^{3+} .

Equation becomes:

$2\text{Al}^{3+} + 3\text{SO}_4^{2-} \rightarrow \text{Al}_2(\text{SO}_4)_3$. You simply place the valency of one ion, as a whole number, in front of the other ion, and vice versa.

Remember to encase the SO_4 in brackets. **Why?** Because we are dealing with the sulfate ion, SO_4^{2-} , and it is this ion that is 2- charged (not just the O_4), so we have to ensure that the "ion" is bracketed. Now to check, the 2 times $3^+ = 6^+$, and 3 times $2^- = 6^-$. We have equal amounts of positive ions, and equal amounts of negative ions.

Another example:

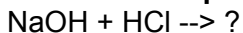

Na is Na^+ , OH is OH^- , so this gave us NaOH. Originally, the one positive canceled the one negative.

HCl is $\text{H}^+ + \text{Cl}^-$, this gave us HCl.

Reaction is going to be the Na^+ reacting with a negatively charged ion. This will have to be the chlorine, Cl^- , because at the moment the Na^+ is tied to the OH^- . **So:** $\text{Na}^+ + \text{Cl}^- \rightarrow \text{NaCl}$
The H^+ from the HCl will react with a negative (-) ion this will be the OH^- from the NaOH.

So: $\text{H}^+ + \text{OH}^- \rightarrow \text{H}_2\text{O}$ (water).

The complete reaction can be written:

$\text{NaOH} + \text{HCl} \rightarrow \text{NaCl} + \text{H}_2\text{O}$. We have **equal amounts** of all atoms **each side** of the equation, so the equation is **balanced**.

or

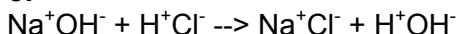

Something More Difficult:

$\text{Mg}(\text{OH})_2 + \text{H}_3\text{PO}_4 \rightarrow ?$ (equation on left **not** balanced)

$\text{Mg}^{2+} 2\text{OH}^- + 3\text{H}^+\text{PO}_4^{3-} \rightarrow ?$ (equation on left **not** balanced), so let us rewrite the equation in **ionic form**.

The Mg^{2+} **needs to react with a negatively charged ion**, this will be the PO_4^{3-} ,

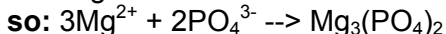

(**Remember** the **swapping** of the positive or negative charges on the ions in the **left side** of the equation, and placing it in front of each ion, and then placing this number after each ion on the **right side** of the equation)

What is left is the H^+ from the H_3PO_4 and this will react with a negative ion, we only have the OH^- from the $\text{Mg}(\text{OH})_2$ left for it to react with.

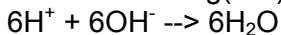

Where did I get the 6 from? When I balanced the Mg^{2+} with the PO_4^{3-} , the equation became $3\text{Mg}^{2+} + 2\text{PO}_4^{3-} \rightarrow \text{Mg}_3(\text{PO}_4)_2$

Therefore, I must have required $3\text{Mg}(\text{OH})_2$ to begin with, and $2\text{H}_3\text{PO}_4$, (because we originally had $(\text{OH})_2$ attached to the Mg, and H_3 attached to the PO_4 . I therefore have 2H_3 reacting with $3(\text{OH})_2$. We have to write this, on the **left side** of the equation, as $6\text{H}^+ + 6\text{OH}^-$ because we need it in ionic form.

The equation becomes:

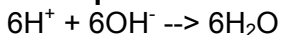

The full equation is now balanced and is:

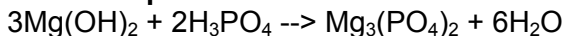

I have purposely split the equation into segments of reactions. This is showing you which ions are reacting with each other. Once you get the idea of equations you will not need this step.

The balancing of equations is simple. You need to learn the valency of the common ions (see tables). The rest is pure mathematics; you are balancing valency charges, positives versus negatives. You have to have the **same number of negatives**, or **positives**, each side of the equation, and the **same number of ions or atoms** each side of the equation.

If one ion, example Al^{3+} , (3 positive charges) reacts with another ion, example OH^- (one negative ion) then we require 2 more negatively charged ions (in this case OH^-) to counteract the 3 positive charges the Al^{3+} contains.

Take my earlier hint, place the 3 from the Al^{3+} in front of the OH^- , now reads 3OH^- , place the 1 from the hydroxyl OH^- in front of the Al^{3+} , now stays the same, Al^{3+} (the 1 is **never** written in chemistry equations).

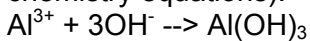

The 3 is simply written in front of the OH^- , a recognized ion, there are no brackets placed around the OH^- . On the right hand side of the equation, all numbers in front of each ion on the left hand side of the equation are placed after each same ion on the right side of the equation. Brackets are used in the right side of the equation because the result is a compound. Brackets are also used for compounds (reactants) in the left side of equations, as in $3\text{Mg}(\text{OH})_2 + 2\text{H}_3\text{PO}_4 \rightarrow ?$



The basic routes for a chemical to enter the body in a laboratory setting are: inhalation, skin and eye contact, ingestion, and injection. The prevention of entry by one of these routes can be accomplished by control mechanisms such as engineering controls, personal protective equipment, and administrative controls. Each route can be minimized by a variety of control measures depending on the hazard and operation.

Chemistry of Chlorination

Chlorine can be added as sodium hypochlorite, calcium hypochlorite or chlorine gas. When any of these is added to water, chemical reactions occur as these equations show:



All three forms of chlorine produce hypochlorous acid (HOCl) when added to water. Hypochlorous acid is a weak acid but a strong disinfecting agent. The amount of hypochlorous acid depends on the pH and temperature of the water. Under normal water conditions, hypochlorous acid will also chemically react and break down into a hypochlorite ion.

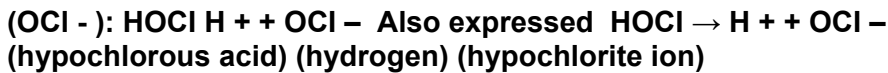

The hypochlorite ion is a much weaker disinfecting agent than hypochlorous acid, about 100 times less effective.

Let's now look at how pH and temperature affect the ratio of hypochlorous acid to hypochlorite ions. As the temperature is decreased, the ratio of hypochlorous acid increases. Temperature plays a small part in the acid ratio. Although the ratio of hypochlorous acid is greater at lower temperatures, pathogenic organisms are actually harder to kill. All other things being equal, higher water temperatures and a lower pH are more conducive to chlorine disinfection.

Types of Residual

If water were pure, the measured amount of chlorine in the water should be the same as the amount added. But water is not 100% pure. There are always other substances (interfering agents) such as iron, manganese, turbidity, etc., which will combine chemically with the chlorine.

This is called the **chlorine demand**. Naturally, once chlorine molecules are combined with these interfering agents, they are not capable of disinfection. It is free chlorine that is much more effective as a disinfecting agent.

So let's look now at how free, total, and combined chlorine are related. When a chlorine residual test is taken, either a total or a free chlorine residual can be read.

Total residual is all chlorine that is available for disinfection.

Total chlorine residual = free + combined chlorine residual.

Free chlorine residual is a much stronger disinfecting agent. Therefore, most water regulating agencies will require that your daily chlorine residual readings be of free chlorine residual.

Break-point chlorination is where the chlorine demand has been satisfied; any additional chlorine will be considered **free chlorine**.

Residual Concentration/Contact Time (CT) Requirements

Disinfection to eliminate fecal and coliform bacteria may not be sufficient to adequately reduce pathogens such as Giardia or viruses to desired levels. Use of the "**CT**" disinfection concept is recommended to demonstrate satisfactory treatment, since monitoring for very low levels of pathogens in treated water is analytically very difficult.

The CT concept, as developed by the United States Environmental Protection Agency (Federal Register, 40 CFR, Parts 141 and 142, June 29, 1989), uses the combination of disinfectant residual concentration (mg/L) and the effective disinfection contact time (in minutes) to measure effective pathogen reduction. The residual is measured at the end of the process, and the contact time used is the T10 of the process unit (time for 10% of the water to pass). CT= Contact time.

CT = Concentration (mg/L) x Time (minutes)



500-pound chlorine gas container and 150-pound Cl₂ gas cylinders. The 1/2 ton is on a scale. Cylinders stand up-right and containers on their sides.

The effective reduction in pathogens can be calculated by reference to standard tables of required CTs (see Appendices A and B).

Required Giardia/Virus Reduction

All surface water treatment systems shall ensure a minimum reduction in pathogen levels: 3-log reduction in Giardia and 4-log reduction in viruses. These requirements are based on unpolluted raw water sources with Giardia levels of = 1 cyst/100 L, and a finished water goal of 1 cyst/100,000 L (equivalent to 1 in 10,000 risk of infection per person per year). Higher raw water contamination levels may require greater removals as shown on Table 4.1.

TABLE 4.1
LEVEL OF GIARDIA REDUCTION
Raw Water Giardia Levels*
Recommended Giardia Log
Reduction

< 1 cyst/100 L 3-log
1 cyst/100 L - 10 cysts/100 L 3-log - 4-log
10 cysts/100 L - 100 cysts/100 L 4-log - 5-log
> 100 cysts/100 L > 5-log

*Use geometric means of data to determine raw water Giardia levels for compliance.

Required CT Value

Required CT values are dependent on pH, residual concentration, temperature, and the disinfectant used. The tables attached to Appendices A and B shall be used to determine the required CT.

Calculation and Reporting of CT Data

Disinfection CT values shall be calculated daily, using either the maximum hourly flow and the disinfectant residual at the same time, or by using the lowest CT value if it is calculated more frequently. Actual CT values are then compared to required CT values.

Results shall be reported as a reduction Ratio, along with the appropriate pH, temperature, and disinfectant residual. The reduction Ratio must be greater than 1.0 to be acceptable. Users may also calculate and record actual log reductions. **Reduction Ratio = CT actual ÷ CT required**



Here is an operator checking for leaks with Ammonia. If there is a Cl₂ leak, you will be able to see a white smoke. Even if you cannot smell the chlorine, the ammonia will find it.

Using DPD Method for Chlorine Residuals N, N – diethyl-p-phenylenediamine



Small portable chlorine measuring kit. The redder the mixture the “hotter” or stronger the chlorine in solution.

Measuring Chlorine Residual

Chlorine residual is the amount of chlorine remaining in water that can be used for disinfection. A convenient, simple and inexpensive way to measure chlorine residual is to use a small portable kit with pre-measured packets of chemicals that are added to water. (Make sure you buy a test kit using the **DPD method**, and not the outdated orthotolodine method.)

Chlorine test kits are very useful in adjusting the chlorine dose you apply. You can measure what chlorine levels are being found in your system (especially at the far ends).

Free chlorine residuals need to be checked and recorded daily. These results should be kept on file for a health or regulatory agency inspection during a regular field visit.

The most accurate method for determining chlorine residuals is to use the laboratory amperometric titration method.

Chlorine (DDBP)

Today, most of our drinking water supplies are free of the micro-organisms — viruses, bacteria, and protozoa — that cause serious and life-threatening diseases, such as cholera and typhoid fever. This is largely due to the introduction of water treatment, particularly chlorination, at the turn of the century.

Living cells react with chlorine and reduce its concentration while they die. Their organic matter and other substances that are present convert to chlorinated derivatives, some of which are effective killing agents. Chlorine present as Cl, HOCl, and OCl⁻ is called **free available chlorine** and that which is bound but still effective is **combined chlorine**. A particularly important group of compounds with combined chlorine is the chloramines formed by reactions with ammonia.

One especially important feature of disinfection using chlorine is the ease of overdosing to create a "**residual**" concentration. There is a constant danger that safe water leaving the treatment plant may become contaminated later. There may be breaks in water mains, loss of pressure that permits an inward leak, or plumbing errors. This residual concentration of chlorine provides some degree of protection right to the water faucet. With free available chlorine, a typical residual is from 0.1 to 0.5 ppm. Because chlorinated organic compounds are less effective, a typical residual is 2 ppm for combined chlorine.

There will be no chlorine residual unless there is an excess over the amount that reacts with the organic matter present. However, reaction kinetics complicates interpretation of chlorination data. The correct excess is obtained in a method called "**Break Point Chlorination**".

Chlorine By-Products

Chlorination by-products are the chemicals formed when the chlorine used to kill disease-causing micro-organisms reacts with naturally occurring organic matter (i.e., decay products of vegetation) in the water. The most common chlorination by-products found in U.S. drinking water supplies are the trihalomethanes (**THMs**).

The Principal Trihalomethanes are:

Chloroform, bromodichloromethane, chlorodibromomethane, and bromoform. Other less common chlorination by-products includes the haloacetic acids and haloacetonitriles. The amount of THMs formed in drinking water can be influenced by a number of factors, including the season and the source of the water. For example, THM concentrations are generally lower in winter than in summer, because concentrations of natural organic matter are lower and less chlorine is required to disinfect at colder temperatures. THM levels are also low when wells or large lakes are used as the drinking water source, because organic matter concentrations are generally low in these sources. The opposite — high organic matter concentrations and high THM levels — is true when rivers or other surface waters are used as the source of the drinking water.

Health Effects

Laboratory animals exposed to very high levels of THMs have shown increased incidences of cancer. Also, several studies of cancer incidence in human populations have reported associations between long-term exposure to high levels of chlorination by-products and an increased risk of certain types of cancer.

For instance, a recent study conducted in the Great Lakes basin reported an increased risk of bladder and possibly colon cancer in people who drank chlorinated surface water for 35 years or more.

Possible relationships between exposure to high levels of THMs and adverse reproductive effects in humans have also been examined recently. In a California study, pregnant women who consumed large amounts of tap water containing elevated levels of THMs were found to have an increased risk of spontaneous abortion. The available studies on health effects do not provide conclusive proof of a relationship between exposure to THMs and cancer or reproductive effects, but indicate the need for further research to confirm their results and to assess the potential health effects of chlorination by-products other than THMs.



Chlorine storage room, notice the vents at the bottom and top. The bottom vent will allow the gas to ventilate because Cl_2 gas is heavier than air.

Risks and Benefits of Chlorine

Current evidence indicates that the benefits of chlorinating our drinking water — reduced incidence of water-borne diseases — are much greater than the risks of health effects from THMs.

Although other disinfectants are available, chlorine continues to be the choice of water treatment experts. When used with modern water filtration practices, chlorine is effective against virtually all infective agents — bacteria, viruses, and protozoa. It is easy to apply, and most importantly, small amounts of chlorine remain in the water and continue to disinfect throughout the distribution system. This ensures that the water remains free of microbial contamination on its journey from the treatment plant to the consumer's tap.

A number of cities use ozone to disinfect their source water and to reduce THM formation. Although ozone is a highly effective disinfectant, it breaks down quickly, so that small amounts of chlorine or other disinfectants must be added to the water to ensure continued disinfection as the water is piped to the consumer's tap. Modifying water treatment facilities to use ozone can be expensive, and ozone treatment can create other undesirable by-products that may be harmful to health if they are not controlled (i.e., bromate).

Examples of other disinfectants include chloramines and chlorine dioxide. Chloramines are weaker disinfectants than chlorine, especially against viruses and protozoa; however, they are very persistent and, as such, can be useful for preventing re-growth of microbial pathogens in drinking water distribution systems.

Chlorine dioxide can be an effective disinfectant, but it forms chlorate and chlorite, compounds whose toxicity has not yet been fully determined. Assessments of the health risks from these and other chlorine-based disinfectants and chlorination by-products are currently under way. In general, the preferred method of controlling chlorination by-products is removal of the naturally occurring organic matter from the source water so it cannot react with the chlorine to form by-products. THM levels may also be reduced through the replacement of chlorine with alternative disinfectants. A third option is removal of the by-products by adsorption on activated carbon beds. It is extremely important that water treatment plants ensure the methods used to control chlorination by-products do not compromise the effectiveness of water disinfection.

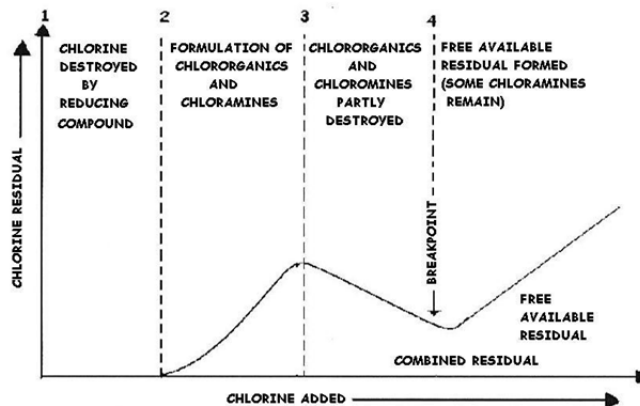

Chlorinator Parts

- Ejector
- Check Valve Assembly
- Rate Valve
- Diaphragm Assembly
- Interconnection Manifold
- Rotameter Tube and Float
- Pressure Gauge
- Gas Supply



Chlorine measurement devices or Rotameters.



Safety Information: There is a fusible plug on every chlorine gas cylinder. This metal plug will melt at 158° to 165° F. This is to prevent a build-up of excessive pressure and the possibility of cylinder rupture due to fire or high temperatures.

Chlorination Equipment Requirements

For all water treatment facilities, chlorine gas under pressure shall not be permitted outside the chlorine room. The chlorine room is the room where chlorine gas cylinders and/or ton containers are stored. Vacuum regulators shall also be located inside the chlorine room. The chlorinator, which is the mechanical gas proportioning equipment, may or may not be located inside the chlorine room.

For new and upgraded facilities, from the chlorine room, chlorine gas vacuum lines should be run as close to the point of solution application as possible. Injectors should be located to minimize the length of pressurized chlorine solution lines. A gas pressure relief system shall be included in the gas vacuum line between the vacuum regulator(s) and the chlorinator(s) to ensure that pressurized chlorine gas does not enter the gas vacuum lines leaving the chlorine room.

The gas pressure relief system shall vent pressurized gas to the atmosphere at a location that is not hazardous to plant personnel; the vent line should be run in such a manner that moisture collecting traps are avoided. The vacuum regulating valve(s) shall have positive shutdown in the event of a break in the downstream vacuum lines. As an alternative to chlorine gas, it is permissible to use hypochlorite with positive displacement pumping. Anti-siphon valves shall be incorporated in the pump heads or in the discharge piping.

Capacity

The chlorinator shall have the capacity to dose enough chlorine to overcome the demand and maintain the required concentration of the "**free**" or "**combined**" chlorine.

Methods of Control

The chlorine feed system shall be automatic proportional controlled, automatic residual controlled, or compound loop controlled. In the automatic proportional controlled system, the equipment adjusts the chlorine feed rate automatically in accordance with the flow changes to provide a constant pre-established dosage for all rates of flow. In the automatic residual controlled system, the chlorine feeder is used in conjunction with a chlorine residual analyzer which controls the feed rate of the chlorine feeders to maintain a particular residual in the treated water. In the compound loop control system, the feed rate of the chlorinator is controlled by a flow proportional signal and a residual analyzer signal to maintain particular chlorine residual in the water. Manual chlorine feed systems may be installed for groundwater systems with constant flow rate.

Standby Provision

As a safeguard against malfunction and/or shut-down, standby chlorination equipment having the capacity to replace the largest unit shall be provided. For uninterrupted chlorination, gas chlorinators shall be equipped with an automatic changeover system. In addition, spare parts shall be available for all chlorinators.



Weigh Scales

Scales for weighing cylinders shall be provided at all plants using chlorine gas to permit an accurate reading of total daily weight of chlorine used. At large plants, scales of the recording and indicating type are recommended. At a minimum, a platform scale shall be provided. Scales shall be of corrosion-resistant material. Read the scales daily and at the same time.

Securing Cylinders

All chlorine cylinders shall be securely positioned to safeguard against movement. Tag the cylinder "**empty**" and store upright and chained. Ton containers may not be stacked.

Chlorine Leak Detection

Automatic chlorine leak detection and related alarm equipment shall be installed at all water treatment plants using chlorine gas. Leak detection shall be provided for the chlorine rooms. Chlorine leak detection equipment should be connected to a remote audible and visual alarm system and checked on a regular basis to verify proper operation.

Leak detection equipment shall not automatically activate the chlorine room ventilation system in such a manner as to discharge chlorine gas. During an emergency if the chlorine room is unoccupied, the chlorine gas leakage shall be contained within the chlorine room itself in order to facilitate a proper method of clean-up.

Consideration should also be given to the provision of caustic soda solution reaction tanks for absorbing the contents of leaking one-ton cylinders where such cylinders are in use. Chlorine leak detection equipment may not be required for very small chlorine rooms with an exterior door (i.e., floor area less than 3m²). You can use a spray solution of Ammonia or a rag soaked with Ammonia to detect a small Cl₂ leak. If there is a leak, the ammonia will create a white colored smoke, Ammonium Chloride.

Safety Equipment

The facility shall be provided with personnel safety equipment to include the following: Respiratory equipment, safety shower, eyewash, gloves, eye protection, protective clothing, cylinder and/or ton repair kits.

Respiratory equipment shall be provided which has been approved under the Occupational Health and Safety Act, General Safety Regulation - Selection of Respiratory Protective Equipment. Equipment shall be in close proximity to the access door(s) of the chlorine room.

Chlorine Room Design Requirements

Where gas chlorination is practiced, the gas cylinders and/or the ton containers up to the vacuum regulators shall be housed in a gas-tight, well illuminated, corrosion resistant and mechanically ventilated enclosure. The chlorinator may or may not be located inside the chlorine room. The chlorine room shall be located at the ground floor level.

Ventilation

Gas chlorine rooms shall have entirely separate exhaust ventilation systems capable of delivering one complete air change per minute during periods of chlorine room occupancy only - there shall be no continuous ventilation. The air outlet from the room shall be 150 mm above the floor and the point of discharge located to preclude contamination of air inlets to buildings or areas used by people. The vents to the outside shall have insect screens. Air inlets should be louvered near the ceiling, the air being of such temperature as to not adversely affect the chlorination equipment.

Separate switches for fans and lights shall be outside the room at all entrance or viewing points, and a clear wire-reinforced glass window shall be installed in such a manner as to allow the operator to inspect from the outside of the room.

Heating

Chlorine rooms shall have separate heating systems, if a forced air system is used to heat the building. Hot water heating system for the building will negate the need for a separate heating system for the chlorine room. The heat should be controlled at approximately 15°C. Cylinders or containers shall be protected to ensure that the chlorine maintains its gaseous state when entering the chlorinator.

Access

All access to the chlorine room shall only be from the exterior of the building. Visual inspection of the chlorination equipment from inside may be provided by the installation of glass window(s) in the walls of the chlorine room. Windows should be at least 0.20 m² in area, and be made of clear wire reinforced glass. There should also be a '**panic bar**' on the inside of the chlorine room door for emergency exit.

Storage of Chlorine Cylinders

If necessary, a separate storage room may be provided to simply store the chlorine gas cylinders, with no connection to the line. The chlorine cylinder storage room shall have access either to the chlorine room or from the plant exterior, and arranged to prevent the uncontrolled release of spilled gas. Chlorine gas storage room shall have provision for ventilation at thirty air changes per hour. Viewing glass windows and a panic button on the inside of door should also be provided. In very large facilities, entry into the chlorine rooms may be through a vestibule from outside.

Scrubbers

For facilities located within residential or densely populated areas, consideration shall be given to provide scrubbers for the chlorine room.

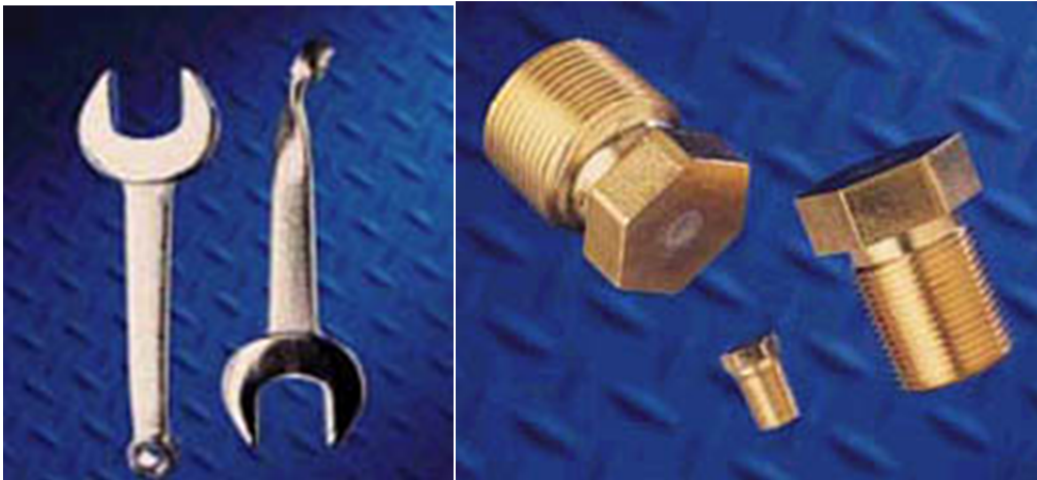

Chlorine wrenches and chlorine cylinder fusible plugs. After a couple of months, the wrenches will start corroding from the acid created from the moisture and chlorine gas. In fact, everything will corrode, including your teeth.

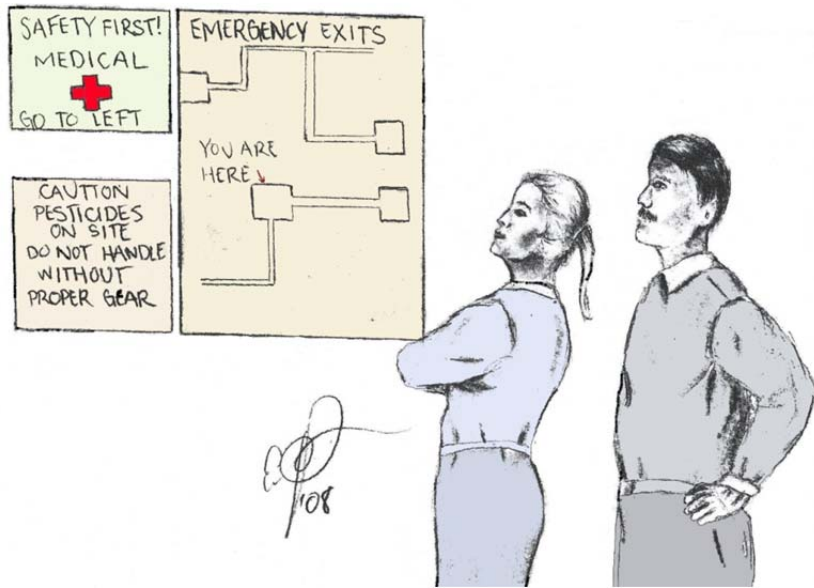

Chlorine is a greenish-yellow, noncombustible gas at room temperature and atmospheric pressure. The intermediate water solubility of chlorine accounts for its effect on the upper airway and the lower respiratory tract. Exposure to chlorine gas may be prolonged, because its moderate water solubility may not cause upper airway symptoms for several minutes. In addition, the density of the gas is greater than that of air, causing it to remain near ground level and increasing exposure time. The odor threshold for chlorine is approximately 0.3-0.5 parts per million (ppm); however, distinguishing toxic air levels from permissible air levels may be difficult until irritative symptoms are present.

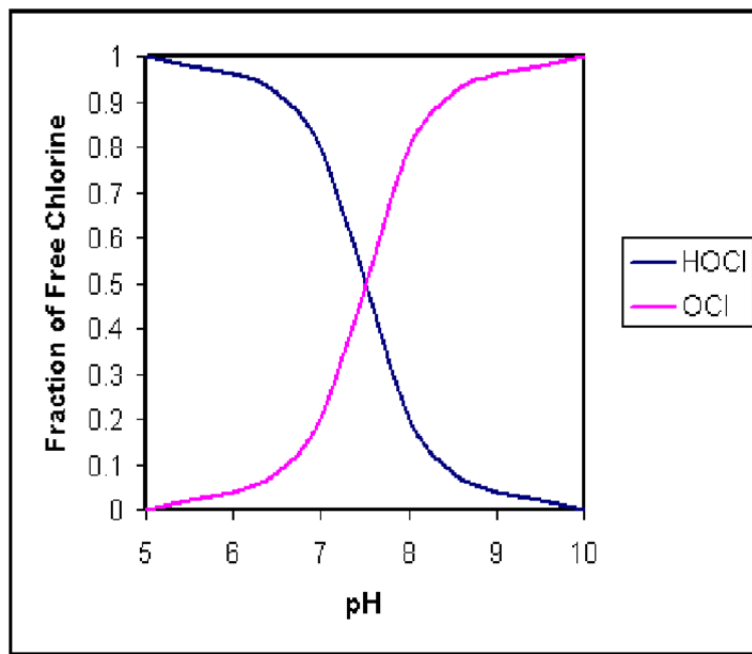

Troubleshooting Hypochlorination Problems

Problem

1. Chemical feed pump won't run.
2. Low chlorine residual at POE. (Point of Entry)
2. Low chlorine residual at POE.
3. Chemical feed pump won't prime.
4. Loss of prime

Possible Causes

- 1A. No power.
- 1B. Electrical problem with signal from well pump or flow sensor.
- 1C. Motor failure.
- 2A. Improper procedure for running chlorine residual test or expired chemical reagents.
- 2B. Pump not feeding an adequate quantity of chlorine.
- 2C. Change in raw water quality.
- 2D. Pump **air bound**.
- 2E. Chlorine supply tank empty.
- 2F. Reduced effectiveness of chlorine solution.
- 2G. Damaged suction or discharge lines. (cracks or crimps)
- 2H. Connection at point of **injection** clogged or leaking.
- 3A. Speed and stroke setting inadequate.
- 3B. Suction lift too high due to feed pump relocation.
- 3C. Discharge pressure too high.
- 3D. Suction fitting clogged.
- 3E. Trapped air in suction line.
- 3F. Suction line not submerged in solution.
- 4A. Solution tank empty.
- 4B. Air leaks in suction fittings.
- 4C. Foot valve not in vertical position.
- 4D. Air trapped in suction tubing.

Possible Solutions

- 1A. Check to see if plug is securely in place.
Insure that there is power to the outlet and control systems.
- 1B. Check pump motor starter. Bypass flow sensor to determine if pump will operate manually.
- 1C. Check manufacturer's information.
- 2A Check expiration date on **chemical reagents**. Check test procedure as described in test kit manual. Speed or stroke setting too low.
- 2B. Damaged **diaphragm** or suction leak.
- 2C. Test raw water for constituents that may cause increased chlorine demand. (i.e. iron, manganese, etc.)
- 2D. Check foot valve.
- 2E. Fill supply tank.
- 2F. Check date that chlorine was received. Sodium hypochlorite solution may lose effectiveness after 30 days. If that is the case, the feed rate must be increased to obtain the desired residual.
- 2G. Clean or repair lines with problems.

2H. Flush line and connection with mild acid such as **Acetic** or **Muriatic**. Replace any damaged parts that may be leaking.

3A. Check manufacturers' recommendations for proper settings to prime pump.

3B. Check maximum suction lift for pump and relocate as necessary.

3C. Check well pump discharge pressure.

Check pressure rating on chemical feed pump.

3D. Clean or replace screen.

3E. Insure all fittings are tight.

3F. Add chlorine solution to supply tank.

4A. Fill tank.

4B. Check for cracked fittings.

4C. Adjust foot valve to proper position.

4D. Check connections and fittings.



Chlorine Titration



These chlorine gas containers are unprotected and not fenced in. This is a huge security violation and a huge safety risk to the public. You can see a fence in the rear, but in reality, there was not complete fencing or any type of security in place.

Alternate Disinfectants

Chloramine

Chloramine is a very weak disinfectant for Giardia and virus reduction. It is recommended that it be used in conjunction with a stronger disinfectant. It is best utilized as a stable distribution system disinfectant.

In the production of chloramines, the ammonia residuals in the finished water, when fed in excess of the stoichiometric amount needed, should be limited to inhibit growth of nitrifying bacteria.

Chlorine Dioxide

Chlorine dioxide may be used for either taste and odor control or as a pre-disinfectant. Total residual oxidants (including chlorine dioxide and chlorite, but excluding chlorate) shall not exceed 0.30 mg/L during normal operation or 0.50 mg/L (including chlorine dioxide, chlorite and chlorate) during periods of extreme variations in the raw water supply.

Chlorine dioxide provides good Giardia and virus protection, but its use is limited by the restriction on the maximum residual of 0.5 mg/L ClO_2 /chlorite/chlorate allowed in finished water. This limits usable residuals of chlorine dioxide at the end of a process unit to less than 0.5 mg/L.

Where chlorine dioxide is approved for use as an oxidant, the preferred method of generation is to entrain chlorine gas into a packed reaction chamber with a 25% aqueous solution of sodium chlorite (NaClO_2).

Warning

Dry sodium chlorite is explosive and can cause fires in feed equipment if leaking solutions or spills are allowed to dry out.

Ozone

Ozone is a very effective disinfectant for both Giardia and viruses. Ozone CT values (contact time) must be determined for the ozone basin alone; an accurate T10 value must be obtained for the contact chamber, residual levels measured through the chamber and an average ozone residual calculated.

Ozone does not provide a system residual and should be used as a primary disinfectant only in conjunction with free and/or combined chlorine.

Ozone does not produce chlorinated byproducts (such as trihalomethanes) but it may cause an increase in such byproduct formation if it is fed ahead of free chlorine; ozone may also produce its own oxygenated byproducts such as aldehydes, ketones, or carboxylic acids. Any installed ozonation system must include adequate ozone leak detection alarm systems, and an ozone off-gas destruction system.

Ozone may also be used as an oxidant for removal of taste and odor, or may be applied as a pre-disinfectant.

Amperometric Titration

The chlorination of water supplies and polluted waters serves primarily to destroy or deactivate disease-producing microorganisms. A secondary benefit, particularly in treating drinking water, is the overall improvement in water quality resulting from the reaction of chlorine with ammonia, iron, manganese, sulfide, and some organic substances.

Chlorination may produce adverse effects. Taste and odor characteristics of phenols and other organic compounds present in a water supply may be intensified. Potentially carcinogenic chloro-organic compounds such as chloroform may be formed.

Combined chlorine formed on chlorination of ammonia- or amine-bearing waters adversely affects some aquatic life. To fulfill the primary purpose of chlorination and to minimize any adverse effects, it is essential that proper testing procedures be used with a foreknowledge of the limitations of the analytical determination.

Chlorine applied to water in its molecular or hypochlorite form initially undergoes hydrolysis to form free chlorine consisting of aqueous molecular chlorine, hypochlorous acid, and hypochlorite ion. The relative proportion of these free chlorine forms is pH- and temperature-dependent. At the pH of most waters, hypochlorous acid and hypochlorite ion will predominate.

Free chlorine reacts readily with ammonia and certain nitrogenous compounds to form combined chlorine. With ammonia, chlorine reacts to form the chloramines: monochloramine, dichloramine, and nitrogen trichloride. The presence and concentrations of these combined forms depend chiefly on pH, temperature, initial chlorine-to-nitrogen ratio, absolute chlorine demand, and reaction time. Both free and combined chlorine may be present simultaneously. Combined chlorine in water supplies may be formed in the treatment of raw waters containing ammonia or by the addition of ammonia or ammonium salts.

Chlorinated wastewater effluents, as well as certain chlorinated industrial effluents, normally contain only combined chlorine. Historically the principal analytical problem has been to distinguish between free and combined forms of chlorine.



Hach's AutoCAT 9000™ Automatic Titrator is the newest solution to hit the disinfection industry – a comprehensive, bench top chlorine-measurement system that does it all: calibration, titration, calculation, real-time graphs, graphic print output, even electrode cleaning. More a laboratory assistant than an instrument, the AutoCAT 9000 gives you, high throughput, performs the titration and calculates concentration, all automatically:

- Forward titration: USEPA-accepted methods for free and total chlorine and chlorine dioxide with chlorite
- Back titration: USEPA-accepted method for total chlorine in wastewater
- Accurate, yet convenient, the easiest way to complete ppb-level amperometric titration

If you're dechlorinating, modifying your current disinfectant delivery, changing over to another chlorine species, or adjusting disinfection processes to meet new regulations, this is the workhorse system that yields the fast, accurate residual readings you need.

Additional Drinking Water Methods (Non-EPA) for Chemical Parameters

Method	Method Focus	Title	Location	Source
4500-Cl ⁻ B	Chloride by Silver Nitrate Titration	Standard Methods for the Examination of Water and Wastewater, 18th & 19th Ed.	Included in Standard Methods	American Water Works Assn. (AWWA)
4500-Cl ⁻ D	Chloride by Potentiometric Method	Standard Methods for the Examination of Water and Wastewater, 18th, 19th & 20th Editions	Included in Standard Methods	American Water Works Assn. (AWWA)
4500-Cl D	Chlorine Residual by Amperometric Titration (Stage 1 DBP use SM 19th Ed. only)	Standard Methods for the Examination of Water and Wastewater, 18th, 19th & 20th Editions	Included in Standard Methods	American Water Works Assn. (AWWA)
4500-Cl E	Chlorine Residual by Low Level Amperometric Titration (Stage 1 DBP use SM 19th Ed. only)	Standard Methods for the Examination of Water and Wastewater, 18th, 19th & 20th Editions	Included in Standard Methods	American Water Works Assn. (AWWA)
4500-Cl F	Chlorine Residual by DPD Ferrous Titration (Stage 1 DBP use SM 19th Ed. only)	Standard Methods for the Examination of Water and Wastewater, 18th, 19th & 20th Editions	Included in Standard Methods	American Water Works Assn. (AWWA)
4500-Cl G	Chlorine Residual by DPD Colorimetric Method (Stage 1 DBP use SM 19th Ed. only)	Standard Methods for the Examination of Water and Wastewater, 18th, 19th & 20th Editions	Included in Standard Methods	American Water Works Assn. (AWWA)
4500-Cl H	Chlorine Residual by Syringaldazine (FACTS) Method (Stage 1 DBP use SM 19th Ed. only)	Standard Methods for the Examination of Water and Wastewater, 18th, 19th & 20th Editions	Included in Standard Methods	American Water Works Assn. (AWWA)
4500-Cl I	Chlorine Residual by Iodometric Electrode Technique (Stage 1 DBP use SM 19th Ed. only)	Standard Methods for the Examination of Water and Wastewater, 18th, 19th & 20th Editions	Included in Standard Methods	American Water Works Assn. (AWWA)
4500-ClO ₂ C	Chlorine Dioxide by the Amperometric Method I	Standard Methods for the Examination of Water and Wastewater, 18th, 19th & 20th Editions	Included in Standard Methods	American Water Works Assn. (AWWA)
4500-ClO ₂ D	Chlorine Dioxide by the DPD Method (Stage 1 DBP use SM 19th Ed. only)	Standard Methods for the Examination of Water and Wastewater, 18th, 19th & 20th Editions	Included in Standard Methods	American Water Works Assn. (AWWA)
4500-ClO ₂ E	Chlorine Dioxide by the Amperometric Method II (Stage 1 DBP use SM 19th Ed. only)	Standard Methods for the Examination of Water and Wastewater, 18th, 19th & 20th Editions	Included in Standard Methods	American Water Works Assn. (AWWA)

Chlorine Dioxide Methods

Most tests for chlorine dioxide rely upon its oxidizing properties. Consequently, numerous test kits are readily available that can be adapted to measure chlorine dioxide. In addition, new methods that are specific for chlorine dioxide are being developed. The following are the common analytical methods for chlorine dioxide:

	DPD glycine	Chlorophenol Red	Direct Absorbance	Iodometric Titration	Amperometric Titration
Method Type:	Colorimetric	Colorimetric	Colorimetric	Titrimetric	Titrimetric
How It Works	Glycine removes Cl ₂ ; ClO ₂ forms a pink color, whose intensity is proportional to the ClO ₂ concentration.	ClO ₂ bleaches chlorophenol red indicator. The degree of bleaching is proportional to the concentration of ClO ₂ .	The direct measurement of ClO ₂ is determined between 350 and 450 nm.	Two aliquots are taken one is sparged with N ₂ to remove ClO ₂ . KI is added to the other sample at pH7 and titrated to a colorless endpoint. The pH is lowered to 2, the color allowed to reform and the titration continued. These titrations are repeated on the sparged sample.	
Range	0.5 to 5.0 ppm.	0.1 to 1.0 ppm	100 to 1000 ppm	> 1 ppm	< 1ppm
Interferences	Oxidizers	None	Color, turbidity	Oxidizers	
Complexity	Simple	Moderate	Simple	Moderate	High
Equipment Required	Spectrophotometer or Colorimeter			Titration equipment	Amperometric Titrator
EPA Status	Approved	Not approved	Not approved	Not approved	Approved
Recommendation	Marginal	Yes	Marginal	Yes	Marginal

Recommendations for Preparing/Handling/Feeding Sodium Hypochlorite Solutions

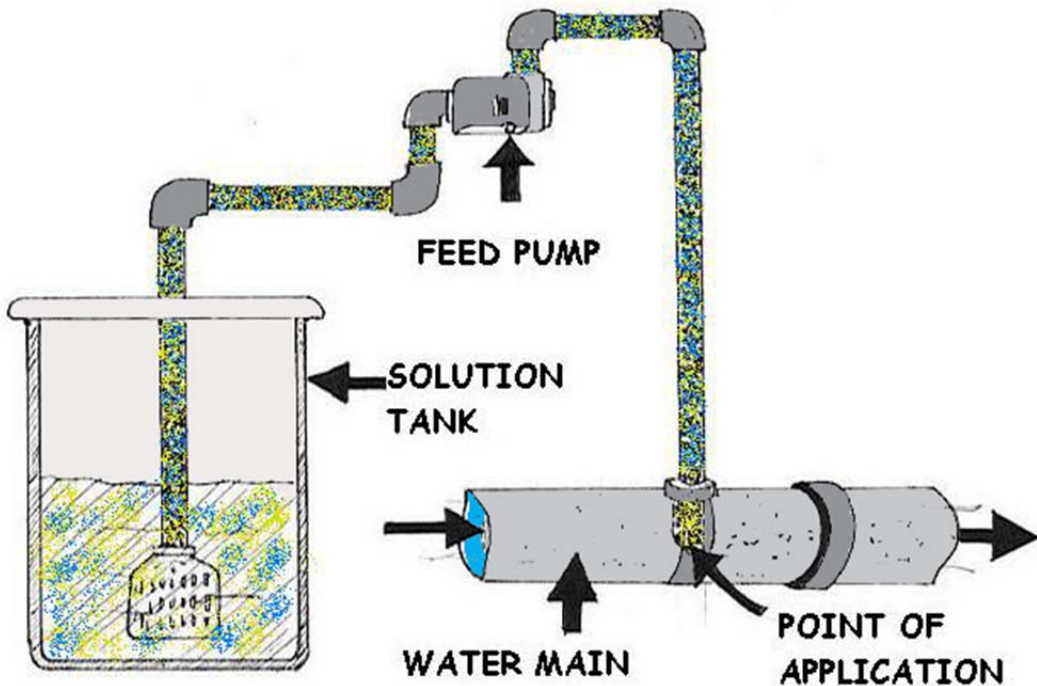

As a result of the pressures brought to bear by Health and Safety requirements, some users of gas have chosen to seek alternative forms of disinfectants for their water and wastewater treatment plants. One of these alternative forms is sodium hypochlorite (**NaOCl**). This is often purchased commercially at 10 to 15% strength.

The handling and storage of NaOCl presents the plant with a new and sometimes unfamiliar, set of equipment installation configurations and operating conditions.

Product Stability The oxidizing nature of this substance means that it should be handled with extreme care. As NaOCl is relatively unstable, it degrades over time.

There are three ways in which NaOCl solutions degrade:

- Chlorate-forming reaction due to age, temperature, light, and minor reduction in pH.
- Oxygen-producing reaction that occurs when metals, such as iron, copper or nickel, or metal oxides are brought into contact with the solution.
- Chlorine-producing reaction when solution pH falls below 6.

There are many factors that affect the stability of a NaOCl solution:

- Initial solution strength.
- pH solution.
- Temperature of the solution.
- Exposure of the solution to sunlight.

Shock Chlorination — Well Maintenance

Shock chlorination is a relatively inexpensive and straightforward procedure used to control bacteria in water wells. Many types of bacteria can contaminate wells, but the most common are iron and sulfate-reducing bacteria.

Health Problems

Although not a cause of health problems in humans, bacteria growth will coat the inside of the well casing, water piping, and pumping equipment, creating problems such as:

- Reduced well yield
- Restricted water flow in distribution lines
- Staining of plumbing fixtures and laundry
- Plugging of water treatment equipment
- “Rotten egg” odor.

Bacteria may be introduced during drilling of a well or when pumps are removed for repair and laid on the ground. However, iron and sulfate-reducing bacteria (as well as other bacteria) can exist naturally in groundwater. A well creates a direct path for oxygen to travel into the ground where it would not normally exist. When a well is pumped, the water flowing in will also bring in nutrients that enhance bacterial growth.

Note: All iron staining problems are not necessarily caused by iron bacteria. The iron naturally present in the water can be the cause.

Ideal Conditions for Iron Bacteria

Water wells provide ideal conditions for iron bacteria. To thrive, iron bacteria require 0.5-4 mg/L of dissolved oxygen, as little as 0.01 mg/L dissolved iron and a temperature range of 5 to 15°C. Some iron bacteria use dissolved iron in the water as a food source.

Signs of Iron and Sulfate-Reducing Bacteria

There are a number of signs that indicate the presence of iron and sulfate-reducing bacteria. They include:

- Slime growth
- Rotten egg odor
- Increased staining.

Slime Growth

The easiest way to check a well and water system for iron bacteria is to examine the inside surface of the toilet flush tank. If you see a greasy slime or growth, iron bacteria are probably present. Iron bacteria leave this slimy by-product on almost every surface the water is in contact with.

Rotten Egg Odor

Sulfate-reducing bacteria can cause a rotten egg odor in water. Iron bacteria aggravate the problem by creating an environment that encourages the growth of sulfate-reducing bacteria in the well. Sulfate-reducing bacteria prefer to live underneath the slime layer that the iron bacteria form. Some of these bacteria produce hydrogen sulfide as a by-product, resulting in a “**rotten egg**” or sulfur odor in the water. Others produce small amounts of sulfuric acid which can corrode the well casing and pumping equipment.



Increased Staining Problems

Iron bacteria can concentrate iron in water sources with low iron content. It can create a staining problem where one never existed before or make an iron staining problem worse as time goes by. Use the following checklist to determine if you have an iron or sulfate-reducing bacteria problem. The first three are very specific problems related to these bacteria. The last two problems can be signs of other problems as well.

Checklist to Determine an Iron or Sulfate-Reducing Bacteria Problem

- Greasy slime on inside surface of toilet flush tank
- Increased red staining of plumbing fixtures and laundry
- Sulfur odor
- Reduced well yield
- Restricted water flow

Mixing a Chlorine Solution

Add a half gallon of bleach to a clean pail with about 3 gallons of water. This is generally sufficient to disinfect a 4 inch diameter well 100 feet deep or less. For wells greater than 100 feet deep or with a larger casing diameter, increase the amount of bleach proportionately.

If you have a dug well with a diameter greater than 18 inches, use 2 to 4 gallons of bleach added directly to the well. Please note that many dug wells are difficult or impossible to disinfect due to their unsanitary construction.

Shock Chlorination — Well Maintenance

Shock Chlorination Method

Shock chlorination is used to control iron and sulfate-reducing bacteria, and to eliminate fecal coliform bacteria in a water system. To be effective, shock chlorination must disinfect the following:

- The entire well depth
- The formation around the bottom of the well
- The pressure system
- Some water treatment equipment
- The distribution system.

To accomplish this, a large volume of super chlorinated water is siphoned down the well to displace all the water in the well and some of the water in the formation around the well.

Effectiveness of Shock Chlorination

With shock chlorination, the entire system (from the water-bearing formation, through the well-bore and the distribution system) is exposed to water which has a concentration of chlorine strong enough to kill iron and sulfate reducing bacteria. Bacteria collect in the pore spaces of the formation and on the casing or screened surface of the well. To be effective, you must use enough chlorine to disinfect the entire cased section of the well and adjacent water-bearing formation. The procedure described below does not completely eliminate iron bacteria from the water system, but it will hold it in check.

To control the iron bacteria, you may have to repeat the procedure each spring and fall as a regular maintenance procedure.

If your well has never been shock chlorinated or has not been done for some time, it may be necessary to use a stronger chlorine solution, applied two or three times, before you notice a significant improvement in the water. You might also consider hiring a drilling contractor to thoroughly clean and flush the well before chlorinating in order to remove any buildup on the casing. In more severe cases, the pump may have to be removed and chemical solutions added to the well and vigorous agitation carried out using special equipment. This is to dislodge and remove the bacterial slime, and should be done by a drilling contractor.

Shock Chlorination Procedure for Small Drilled Wells

A modified procedure is also provided for large diameter wells.

Caution: If your well is low-yielding or tends to pump any silt or sand, you must be very careful using the following procedure because over pumping may damage the well. When pumping out the chlorinated solution, monitor the water discharge for sediment.



Don't mix acids with chlorine. This is a dangerous practice.

Chlorine Exposure Limits

This information is often necessary to pass your certification exam.

* OSHA PEL 1 PPM - IDLH 10 PPM and Fatal Exposure Limit 1,000 PPM

The current Occupational Safety and Health Administration (OSHA) permissible exposure limit (PEL) for chlorine is 1 ppm (3 milligrams per cubic meter ($\text{mg}/\text{m}^{(3)}$)) as a ceiling limit. A worker's exposure to chlorine shall at no time exceed this ceiling level. * IDLH 10 PPM

Physical and chemical properties of chlorine: A yellowish green, nonflammable and liquefied gas with an unpleasant and irritating smell. Can be readily compressed into a clear, amber-colored liquid, a noncombustible gas, and a strong oxidizer. Solid chlorine is about 1.5 times heavier than water and gaseous chlorine is about 2.5 times heavier than air. Atomic number of chlorine is 17. Cl is the elemental symbol and Cl_2 is the chemical formula.

Monochloramine, dichloramine, and trichloramine are also known as Combined Available Chlorine. $\text{Cl}_2 + \text{NH}_4$.

HOCl and OCl^- ; the **OCL-** is the hypochlorite ion and both of these species are known as free available chlorine, they are the two main chemical species formed by chlorine in water. They are known by collectively as hypochlorous acid and the hypochlorite ion. When chlorine gas is added to water, it rapidly hydrolyzes. The chemical equations best describes this reaction is $\text{Cl}_2 + \text{H}_2\text{O} \rightarrow \text{H}^+ + \text{Cl}^- + \text{HOCl}$. Hypochlorous acid is the most germicidal of the chlorine compounds with the possible exception of chlorine dioxide.

Yoke-type connectors should be used on a chlorine cylinder's valve, assuming that the threads on the valve may be worn.

The connection from a chlorine cylinder to a chlorinator should be replaced by using a new, approved gasket on the connector. Always follow your manufacturer's instructions.

On a 1 ton chlorine gas container, the chlorine pressure reducing valve should be located downstream of the evaporator when using an evaporator. This is the liquid chlorine supply line and it is going to be made into chlorine gas.



In water treatment, chlorine is added to the effluent before the contact chamber (before the clear well) for complete mixing. One reason for not adding it directly to the chamber is that the chamber has very little mixing due to low velocities.

Here are several safety precautions when using chlorine gas: in addition to protective clothing and goggles, chlorine gas should be used only in a well-ventilated area so that any leaking gas cannot concentrate. Emergency procedures in the case of a large uncontrolled chlorine leak are to: notify local emergency response team, warn and evacuate people in adjacent areas, and be sure that no one enters the leak area without adequate self-contained breathing equipment.

Here are several symptoms of chlorine exposure: Burning of eyes, nose, and mouth, coughing, sneezing, choking, nausea and vomiting, headaches and dizziness, fatal pulmonary edema, pneumonia and skin blisters. A little Cl_2 will corrode the teeth and then progress to throat cancer.



Approved method for storing a 150 - 200 pound chlorine cylinder: secure each cylinder in an upright position, attach the protective bonnet over the valve, and firmly secure each cylinder. Never store near heat. Always store the empty in an upright, secure position with proper signage. Bottom photograph Chlorine wrenches that have been near Chlorine gas. It takes just a few weeks for a very small undetectable chlorine gas leak to oxidize steel or human teeth.



Fluoride

Some water providers will add fluoride to the water to help prevent cavities in children. Too much fluoride will mottle the teeth.

Chemical Feed

The equipment used for feeding the fluoride to water shall be accurately calibrated before being placed in operation, and at all times shall be capable of maintaining a rate of feed within 5% of the rate at which the machine is set.

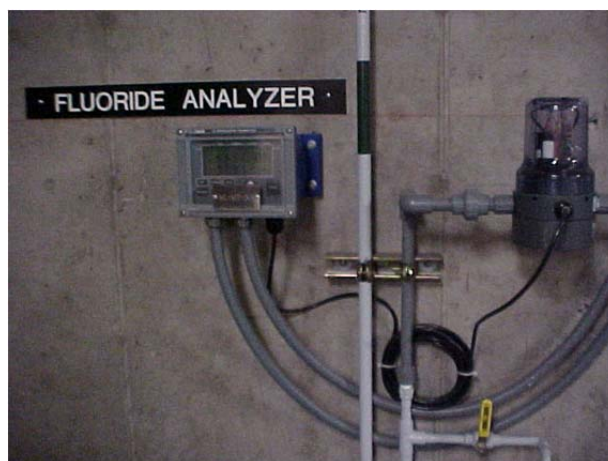

The following chemical feed practices apply:

1. Where a dry feeder of the volumetric or gravimetric type is used, a suitable weighing mechanism shall be provided to check the daily amount of chemical feed.
2. Hoppers should be designed to hold a 24 hour supply of the fluoride compound and designed such that the dust hazard to operators is minimized.
3. Vacuum dust filters shall be installed with the hoppers to prevent dust from rising into the room when the hopper is filled.
4. Dissolving chambers are required for use with dry feeders, and the dissolving chambers shall be designed such that at the required rate of feed of the chemical the solution strength will not be greater than 1/4 of that of a saturated solution at the temperature of the dissolving water. The construction material of the dissolving chamber and associated piping shall be compatible with the fluoride solution to be fed.
5. Solution feeders shall be of the positive displacement type and constructed of material compatible with the fluoride solution being fed.
6. The weight of the daily amount of fluoride fed to water shall be accurately determined.
7. Feeders shall be provided with anti-siphon valves on the discharge side. Wherever possible, positive anti-siphon breakers other than valves shall be provided.
8. A "**day tank**" capable of holding a 24 hour supply of solution should be provided.
9. All equipment shall be sized such that it will be operated in the 20 to 80 percent range of the scale, and be capable of feeding over the entire pumpage range of the plant.
10. Alarm signals are recommended to detect faulty operation of equipment; and,
11. The fluoride solution should be added to the water supply at a point where the fluoride will not be removed by any following treatment processes and where it will be mixed with the water. It is undesirable to inject the fluoride compound or solution directly on-line unless there are provisions for adequate mixing.

Metering

Metering of the total water to be fluoridated shall be provided, and the operation of the feeding equipment is to be controlled. Control of the feed rate shall be automatic/proportional controlled, whereby the fluoride feed rate is automatically adjusted in accordance with the flow changes to provide a constant pre-established dosage for all rates of flow, or (2) automatic/residual controlled, whereby a continuous automatic fluoride analyzer determines the residual fluoride level and adjusts the rate of feed accordingly, or compound loop controlled, whereby the feed rate is controlled by a flow proportional signal and residual analyzer signal to maintain a constant residual.

Alternate Compounds

Any one of the following fluoride compounds may be used:

- 1. Hydrofluosilicic acid,**
- 2. Sodium fluoride or,**
- 3. Sodium silicofluoride.**

Other fluoride compounds may be used, if approved by the EPA.

Chemical Storage and Ventilation

The fluoride chemicals shall be stored separately from other chemicals, and the storage area shall be marked "**FLUORIDE CHEMICALS ONLY**". The storage area should be in close proximity to the feeder, kept relatively dry, and provided with pallets (if using bagged chemical) to allow circulation of air and to keep the containers off the floor.

Record of Performance

Accurate daily records shall be kept. These records shall include:

1. The daily reading of the water meter which controls the fluoridation equipment or that which determines the amount of water to which the fluoride is added.
2. The daily volume of water fluoridated.
3. The daily weight of fluoride compound in the feeder.
4. The daily weight of fluoride compound in stock.
5. The daily weight of the fluoride compound fed to the water; and,
6. The fluoride content of the raw and fluoridated water determined by laboratory analysis, with the frequency of measurement as follows:
 - (i) treated water being analyzed continuously or once daily, and
 - (ii) raw water being analyzed at least once a week.

Sampling

In keeping the fluoride records, the following sampling procedures are required:

1. A sample of raw water and a sample of treated water shall be forwarded to an approved independent laboratory for fluoride analysis once a month.
2. On new installations or during start-ups of existing installations, weekly samples of raw and treated water for a period of not less than four consecutive weeks.
3. In addition to the reports required, the EPA may require other information that is deemed necessary.

Fluoride Safety

The following safety procedures shall be maintained:

1. All equipment shall be maintained at a high standard of efficiency, and all areas and appliances shall be kept clean and free of dust. Wet or damp cleaning methods shall be employed wherever practicable.
2. Personal protective equipment shall be used during the clean-up, and appropriate covers shall be maintained over all fluoride solutions.
3. At all installations, safety features are to be considered and the necessary controls built into the installation to prevent an overdose of fluoride in the water. This shall be done either by use of day tanks or containers, anti-siphon devices, over-riding flow switches, sizing of pump and feeders, determining the length and duration of impulses, or other similar safety devices.
4. Safety features shall also be provided to prevent spills and overflows.

5. Individual dust respirators, chemical safety face shields, rubber gloves, and protective clothing shall be worn by all personnel when handling or being exposed to the fluoride dust.
6. Chemical respirators, rubber gloves, boots, chemical safety goggles and acid proof aprons shall be worn where acids are handled.
7. After use, all equipment shall be thoroughly cleaned and stored in an area free of fluoride dusts. Rubber articles shall be washed in water, and hands shall be washed after the equipment is stored; and,
8. All protective devices, whether for routine or emergency use, shall be inspected periodically and maintained in good operating condition.

Repair and Maintenance

Upon notifying the appropriate local board of health, a fluoridation program may be discontinued when necessary to repair or replace equipment, but shall be placed in operation immediately after the repair replacement is complete. Records shall be maintained and submitted during the period that the equipment is not in operation.



Sample sink

Glossary

ABANDONED WELL: Wells that have been or need to be sealed by an approved method.

ABSENCE OF OXYGEN: The complete absence of oxygen in water described as Anaerobic.

ACCURACY: How closely an instrument measures the true or actual value.

ACID AND BASE ARE MIXED: When an acid and a base are mixed, an explosive reaction occurs and decomposition products are created under certain conditions.

ACID: Slowly add the acid to water while stirring. An operator should not mix acid and water or acid to a strong base.

ACID RAIN: A result of airborne pollutants.

ACTIVATED CHARCOAL (GAC or PAC): Granular Activated Charcoal or Powered Activated Charcoal. Used for taste and odor removal. A treatment technique that is not included in the grading of a water facility.

ACTIVATED CARBON FILTRATION: Can remove organic chemicals that produce off-taste and odor. These compounds are not dangerous to health but can make the water unpleasant to drink. Carbon filtration comes in several forms, from small filters that attach to sink faucets to large tanks that contain removable cartridges. Activated carbon filters require regular maintenance or they can become a health hazard.

ADSORPTION: *Not to be confused with absorption.* Adsorption is a process that occurs when a gas or liquid solute accumulates on the surface of a solid or a liquid (adsorbent), forming a film of molecules or atoms (the adsorbate). It is different from absorption, in which a substance diffuses into a liquid or solid to form a solution. The term sorption encompasses both processes, while desorption is the reverse process. Adsorption is present in many natural physical, biological, and chemical systems, and is widely used in industrial applications such as activated charcoal, synthetic resins, and water purification.

ADSORPTION CLARIFIERS: The concept of the adsorption clarifier package plant was developed in the early 1980s. This technology uses an up-flow clarifier with low-density plastic bead media, usually held in place by a screen. This adsorption media is designed to enhance the sedimentation/clarification process by combining flocculation and sedimentation into one step. In this step, turbidity is reduced by adsorption of the coagulated and flocculated solids onto the adsorption media and onto the solids already adsorbed onto the media. Air scouring cleans adsorption clarifiers followed by water flushing. Cleaning of this type of clarifier is initiated more often than filter backwashing because the clarifier removes more solids. As with the tube-settler type of package plant, the sedimentation/clarification process is followed by mixed-media filtration and disinfection to complete the water treatment.

AIR GAP SEPARATION: A physical separation space that is present between the discharge vessel and the receiving vessel; for an example, a kitchen faucet.

AIR HAMMER: A pneumatic cylindrical hammering device containing a piston used on air rotary rigs. The air hammer's heavy piston moves up and down by the introduction of compressed air creating a hammering action on the bit.

AIR HOOD: The most suitable protection when working with a chemical that produces dangerous fumes.

AIR ENTRAINMENT: The dissolution or inclusion of air bubbles into water.

AIRLIFT: The lifting of water and/or cuttings to the surface by the injection of high pressure bursts of air. Airlift occurs continuously when drilling with air rotary and can be used for well development with a surging technique.

AIR PUMPING: Continuous airlifting to remove water from the well.

AIR ROTARY: A method of rotary well drilling that utilizes compressed air as the primary drilling fluid.

AGGLOMERATION: A jumbled cluster or mass of varied parts. The act or process of agglomerating.

ALKALINITY: Alkalinity or AT is a measure of the ability of a solution to neutralize acids to the equivalence point of carbonate or bicarbonate. Alkalinity is closely related to the acid neutralizing capacity (ANC) of a solution and ANC is often incorrectly used to refer to alkalinity. However, the acid neutralizing capacity refers to the combination of the solution and solids present (e.g., suspended matter, or aquifer solids), and the contribution of solids can dominate the ANC (see carbonate minerals below).

ALTERNATIVE DISINFECTANTS: Disinfectants - other than chlorination (halogens) - used to treat water, e.g. ozone, ultraviolet radiation, chlorine dioxide, and chloramine. There is limited experience and scientific knowledge about the by-products and risks associated with the use of alternatives.

ALGAE: Microscopic plants that are free-living and usually live in water. They occur as single cells floating in water, or as multicellular plants like seaweed or strands of algae that attach to rocks.

ALPHA AND BETA RADIOACTIVITY: Represent two common forms of radioactive decay. Radioactive elements have atomic nuclei so heavy that the nucleus will break apart, or disintegrate spontaneously. When decay occurs, high-energy particles are released. These high-energy particles are called radioactivity. Although radioactivity from refined radioactive elements can be dangerous, it is rare to find dangerous levels of radioactivity in natural waters. An alpha particle is a doubly-charged helium nucleus comprised of two protons, two neutrons, and no electrons. A beta particle is a high-speed electron. Alpha particles do not penetrate matter easily, and are stopped by a piece of paper. Beta particles are much more penetrating and can pass through a millimeter of lead.

ALUMINUM SULFATE: The chemical name for Alum. The molecular formula of Alum is $Al_2(SO_4)_3 \cdot 14H_2O$. It is a cationic polymer.

AMOEBA: Amoeba (sometimes amœba or ameba, plural amoebae) is a genus of protozoa that moves by means of pseudopods, and is well-known as a representative unicellular organism. The word amoeba or ameba is variously used to refer to it and its close relatives, now grouped as the Amoebozoa, or to all protozoa that move using pseudopods, otherwise termed amoeboids.

AMMONIA: NH_3 A chemical made with Nitrogen and Hydrogen and used with chlorine to disinfect water. Most ammonia in water is present as the ammonium ion rather than as ammonia.

AMMONIATOR: A control device which meters gaseous ammonia directly into water under positive pressure.

ANAEROBIC: An abnormal condition in which color and odor problems are most likely to occur.

ANAEROBIC CONDITIONS: When anaerobic conditions exist in either the metalimnion or hypolimnion of a stratified lake or reservoir, water quality problems may make the water unappealing for domestic use without costly water treatment procedures. Most of these problems are associated with Reduction in the stratified waters.

ANEROID: Using no fluid, as in aneroid barometer.

ASEPTIC: Free from the living germs of disease, fermentation, or putrefaction.

ANNULAR SPACE: The space between the borehole wall and either drill piping or casing within a well.

ANNULUS: See Annular Space.

AMMONIA: A chemical made with Nitrogen and Hydrogen and used with chlorine to disinfect water.

AQUICLUDE: A layer or layers of soils or formations which water cannot pass through (ex - solid bedrock or very stiff clay). The opposite of aquifer.

AQUIFER: A saturated layer or layers of soils or formations which water can pass through and be provided in usable quantities to supply wells or springs (ex – saturated semi consolidated sediment or saturated fractured bedrock.) An underground geologic formation capable of storing significant amounts of water.

AQUIFER PARAMETERS: Referring to such attributes as specific capacity, aquifer storage, transmissivity, hydraulic conductivity, gradient, and water levels. Refers to all of the components of Darcy's Law and related parameters.

ARTESIAN AQUIFER: A confined aquifer in which the pressure head results in a water elevation higher than the land surface.

ARTESIAN WELL: A well constructed within an artesian aquifer. When an artesian well is opened it will flow naturally.

As: The chemical symbol of Arsenic.

AS NITROGEN: An expression that tells how the concentration of a chemical is expressed mathematically. The chemical formula for the nitrate ion is NO_3^- , with a mass of 62. The concentration of nitrate can be expressed either in terms of the nitrate ion or in terms of the principal element, nitrogen. The mass of the nitrogen atom is 14. The ratio of the nitrate ion mass to the nitrogen atom mass is 4.43. Thus a concentration of 10 mg/L nitrate expressed as nitrogen would be equivalent to a concentration of 44.3 mg/L nitrate expressed as nitrate ion. When dealing with nitrate numbers it is very important to know how numeric values are expressed.

ASYNCHRONOUS: Not occurring at the same time.

AUGER RIG: A drilling rig, which drives a rotating spiral flange to drill into the earth.

ATOM: The general definition of an ion is an atom with a positive or negative charge. Electron is the name of a negatively charged atomic particle.

BACKFLOW PREVENTION: To stop or prevent the occurrence of, the unnatural act of reversing the normal direction of the flow of liquid, gases, or solid substances back in to the public potable (drinking) water supply. See Cross-connection control.

BACKFLOW: To reverse the natural and normal directional flow of a liquid, gases, or solid substances back in to the public potable (drinking) water supply. This is normally an undesirable effect.

BACKSIPHONAGE: A liquid substance that is carried over a higher point. It is the method by which the liquid substance may be forced by excess pressure over or into a higher point.

BACTERIA: Small, one-celled animals too small to be seen by the naked eye. Bacteria are found everywhere, including on and in the human body. Humans would be unable to live without the bacteria that inhabit the intestines and assist in digesting food. Only a small percentage of bacteria cause disease in normal, healthy humans. Other bacteria can cause infections if they get into a cut or wound. Bacteria are the principal concern in evaluating the microbiological quality of drinking water, because some of the bacteria-caused diseases that can be transmitted by drinking water are potentially life-threatening.

BACTERIOPHAGE: Any of a group of viruses that infect specific bacteria, usually causing their disintegration or dissolution. A bacteriophage (from 'bacteria' and Greek phagein, 'to eat') is any one of a number of viruses that infect bacteria. The term is commonly used in its shortened form, phage. Typically, bacteriophages consist of an outer protein hull enclosing genetic material. The genetic material can be ssRNA (single stranded RNA), dsRNA, ssDNA, or dsDNA between 5 and 500 kilo base pairs long with either circular or linear arrangement. Bacteriophages are much smaller than the bacteria they destroy - usually between 20 and 200 nm in size.

BAILER: A device used to withdrawal water or sediment from a well utilizing a check valve type mechanism.

BARITE: Processed barium sulfate, often used to increase drilling fluid densities in mud rotary.

BATTERY: A source of direct current (**DC**) may be used for standby lighting in a water treatment facility. The electrical current used in a DC system may come from a battery.

BENTONITE: High quality clay composed primarily of montmorillonite. Used to thicken drilling mud in mud rotary drilling and used to form seals in well construction or abandonment.

BEST AVAILABLE TECHNOLOGY ECONOMICALLY ACHIEVABLE (BAT): A level of technology based on the best existing control and treatment measures that are economically achievable within the given industrial category or subcategory.

BEST MANAGEMENT PRACTICES (BMPs): Schedules of activities, prohibitions of practices, maintenance procedures, and other management practices to prevent or reduce the pollution of waters of the U.S. BMPs also include treatment requirements, operating procedures and practices to control plant site runoff, spillage or leaks, sludge or waste disposal, or drainage from raw material storage.

BEST PRACTICABLE CONTROL TECHNOLOGY CURRENTLY AVAILABLE (BPT): A level of technology represented by the average of the best existing wastewater treatment performance levels within an industrial category or subcategory.

BEST PROFESSIONAL JUDGMENT (BPJ): The method used by a permit writer to develop technology-based limitations on a case-by-case basis using all reasonably available and relevant data.

BIT: The primary cutting edge of a drill string.

BLANK CASING: A section of well casing that is solid.

BLOWDOWN: The discharge of water with high concentrations of accumulated solids from boilers to prevent plugging of the boiler tubes and/or steam lines. In cooling towers, blowdown is discharged to reduce the concentration of dissolved salts in the recirculating cooling water.

BOREHOLE DEVIATION: A boreholes' orientation deviates from vertical while drilling.

BOREHOLE GEOPHYSICS: A surveying technique of utilizing specialized tools to measure various physical parameters of the aquifer, formation, and well.

BOREHOLE: The hole that is formed when drilling into the earth.

BOULDER: An individual rock or solid mass of rock larger than 10 inches in diameter.

BREAK POINT CHLORINATION: The process of chlorinating the water with significant quantities of chlorine to oxidize all contaminants and organic wastes and leave all remaining chlorine as free chlorine.

BRIDGING: The tendency of sediment, filter, or seal media to create an obstruction if installed in too small an annulus or to rapidly. Also can occur within filter packs requiring development.

BROMINE: Chemical disinfectant (HALOGEN) that kills bacteria and algae. This chemical disinfectant has been used only on a very limited scale for water treatment because of its handling difficulties. This chemical causes skin burns on contact, and a residual is difficult to obtain.

BUCKET AUGER: A single cylindrical type of auger flight consisting of offset cutting blades at the bottom. A bucket auger rig rotates the bucket and its blades cut into the earth and fill the bucket with cuttings, which are dumped on the surface as needed.

BUFFER: Chemical that resists pH change, e.g. sodium bicarbonate

BUTTON BIT: A bit that is constructed with raised (typically carbide) buttons that strengthen the bit and aid in crushing and grinding efficiency. A button bit may be of a roller, hammer, or percussion type.

CABLE TOOL: (Also called Percussion Drilling) A method of drilling which utilizes the consecutive lifting and dropping of a heavy drill string via a system of cables.

CALCIUM HARDNESS: A measure of the calcium salts dissolved in water.

Ca: The chemical symbol for calcium.

CADMIUM: A contaminant that is usually not found naturally in water or in very small amounts.

CALCIUM HARDNESS: A measure of the calcium salts dissolved in water.

CALCIUM ION: Is divalent because it has a valence of +2.

CALCIUM, MAGNESIUM AND IRON: The three elements that cause hardness in water.

CaOCl₂·4H₂O: The molecular formula of Calcium hypochlorite.

CAPILLARY ACTION: The occurrence of an upward movement of fluid into previously unsaturated soil due to adhesion and surface tension which develops between the fluid and soil particles.

CAPILLARY FRINGE: The uppermost portion of an aquifer where the vadose zone ends. The capillary action of soils permits moisture to extend upwards into the vadose zone within the capillary fringe.

CARBON DIOXIDE GAS: The pH will decrease and alkalinity will change as measured by the Langelier index after pumping carbon dioxide gas into water.

CARBONATE HARDNESS: Carbonate hardness is the measure of Calcium and Magnesium and other hard ions associated with carbonate (CO₃²⁻) and bicarbonate (HCO₃⁻) ions contained in a solution, usually water. It is usually expressed either as parts per million (ppm or mg/L), or in degrees (KH - from the German "Karbonathärte"). One German degree of carbonate hardness is equivalent to about 17.8575 mg/L. Both measurements (mg/L or KH) are usually expressed "as CaCO₃" – meaning the amount of hardness expressed as if calcium carbonate was the sole source of hardness. Every bicarbonate ion only counts for half as much carbonate hardness as a carbonate ion does. If a solution contained 1 liter of water and 50 mg NaHCO₃ (baking soda), it would have a carbonate hardness of about 18 mg/L as CaCO₃. If you had a liter of water containing 50 mg of Na₂CO₃, it would have a carbonate hardness of about 29 mg/L as CaCO₃.

CARBONATE, BICARBONATE AND HYDROXIDE: Chemicals that are responsible for the alkalinity of water.

CARBONATE ROCK: Rock that is composed primarily of calcium carbonate.

CASING DRIVER: A percussion or hammering device used to force casing into the subsurface.

CASING: A column of specially designed pipe of metal or plastic material installed in wells in order to keep a borehole open to permit serviceability of and/or construction and completion of a well within it.

CATHEAD: A specially designed auxiliary reel that normally utilizes heavy rope rather than steel cable. Often used on cable tool or percussion drilling rigs for the operation of drive blocks.

CATHODIC PROTECTION: An operator should protect against corrosion of the anode and/or the cathode by painting the copper cathode. Cathodic protection interrupts corrosion by supplying an electrical current to overcome the corrosion-producing mechanism. Guards against stray current corrosion.

CAUSTIC: NaOH (also called Sodium Hydroxide) is a strong chemical used in the treatment process to neutralize acidity, increase alkalinity or raise the pH value.

CAUSTIC SODA: Also known as sodium hydroxide and is used to raise pH.

CAVERN: Large open spaces (>5ft.) encountered while drilling. More often associated with limestone formations in a karst environment.

CEILING AREA: The specific gravity of ammonia gas is 0.60. If released, this gas will accumulate first at the ceiling area. Cl_2 gas will settle on the floor.

CEMENT GROUT: Cement of fine consistency, capable of being pumped. Used to seal in and around wells.

CENTRALIZER: Stand offs attached to well casing and screen to maintain annular space. In drilling, it has the same meaning as stabilizer or drill collar.

CENTRIFUGAL FORCE: That force when a ball is whirled on a string that pulls the ball outward. On a centrifugal pump, it is that force which throws water from a spinning impeller.

CENTRIFUGAL PUMP: A pump consisting of an impeller fixed on a rotating shaft and enclosed in a casing, having an inlet and a discharge connection. The rotating impeller creates pressure in the liquid by the velocity derived from centrifugal force.

CESIUM (also Caesium): Symbol Cs- A soft, silvery-white ductile metal, liquid at room temperature, the most electropositive and alkaline of the elements, used in photoelectric cells and to catalyze hydrogenation of some organic compounds.

CHAIN OF CUSTODY (COC): A record of each person involved in the possession of a sample from the person who collects the sample to the person who analyzes the sample in the laboratory.

CHAIN OF CUSTODY (COC): A record of each person involved in the possession of a sample from the person who collects the sample to the person who analyzes the sample in the laboratory.

CHECK VALVE: Allows water to flow in only one direction.

CHELATION: A chemical process used to control scale formation in which a chelating agent "captures" scale-causing ions and holds them in solution.

CHEMICAL FEED RATE: Chemicals are added to the water in order to improve the subsequent treatment processes. These may include pH adjusters and coagulants. Coagulants are chemicals, such as alum, that neutralize positive or negative charges on small particles, allowing them to stick together and form larger particles that are more easily removed by sedimentation (settling) or filtration. A variety of devices, such as baffles, static mixers, impellers and in-line sprays, can be used to mix the water and distribute the chemicals evenly.

CHEMICAL OXIDIZER: KMnO_4 or Potassium Permanganate is used for taste and odor control because it is a strong oxidizer which eliminates many organic compounds.

CHEMICAL REACTION RATE: In general, when the temperature decreases, the chemical reaction rate also decreases. The opposite is true for when the temperature increases.

CHEMISORPTION: (or chemical adsorption) Is adsorption in which the forces involved are valence forces of the same kind as those operating in the formation of chemical compounds.

CHLORAMINATION: Treating drinking water by applying chlorine before or after ammonia. This creates a persistent disinfectant residual called chloramines.

CHLORAMINES: A group of chlorine ammonia compounds formed when chlorine combines with organic wastes in the water. Chloramines are not effective as disinfectants and are responsible for eye and skin irritation as well as strong chlorine odors.

CHLORINATION: The process in water treatment of adding chlorine (gas or solid hypochlorite) for purposes of disinfection.

CHLORINE: A chemical used to disinfect water. Chlorine is extremely reactive, and when it comes in contact with microorganisms in water it kills them. Chlorine is added to swimming pools to keep the water safe for swimming. Chlorine is available as solid tablets for swimming pools. Some public water system's drinking water treatment plants use chlorine in a gas form because of the large volumes required. Chlorine is very effective against algae, bacteria and viruses. Protozoa are resistant to chlorine because they have thick coats; protozoa are removed from drinking water by filtration.

CHLORINE DEMAND: Amount of chlorine required to react on various water impurities before a residual is obtained. Also, means the amount of chlorine required to produce a free chlorine residual of 0.1 mg/l after a contact time of fifteen minutes as measured by iodometric method of a sample at a temperature of twenty degrees in conformance with Standard methods.

CHLORINE FEED: Chlorine may be delivered by vacuum-controlled solution feed chlorinators. The chlorine gas is controlled, metered, introduced into a stream of injector water and then conducted as a solution to the point of application.

CHLORINE, FREE: Chlorine available to kill bacteria or algae. The amount of chlorine available for sanitization after the chlorine demand has been met. Also known as chlorine residual.

CIRCULATION: The continual flow of drilling fluid from injection to recovery and recirculation at the surface.

CLEAR WELL: A large underground storage facility sometimes made of concrete. A clear well or a plant storage reservoir is usually filled when demand is low. The final step in the conventional filtration process, the clearwell provides temporary storage for the treated water. The two main purposes for this storage are to have filtered water available for backwashing the filter and to provide detention time (or contact time) for the chlorine (or other disinfectant) to kill any microorganisms that may remain in the water.

ClO₂: The molecular formula of Chlorine dioxide.

COAGULATION: The best pH range for coagulation is between 5 and 7. Mixing is an important part of the coagulation process you want to complete the coagulation process as quickly as possible.

COBBLES: A rock smaller than a boulder but larger than a pebble. A cobble is greater than 2.5 inches in diameter and smaller than 10 inches in diameter.

COLIFORM: Bacteria normally found in the intestines of warm-blooded animals. Coliform bacteria are present in high numbers in animal feces. They are an indicator of potential contamination of water. Adequate and appropriate disinfection effectively destroys coliform bacteria. Public water systems are required to deliver safe and reliable drinking water to their customers 24 hours a day, 365 days a year. If the water supply becomes contaminated, consumers can become seriously ill. Fortunately, public water systems take many steps to ensure that the public has safe, reliable drinking water. One of the most important steps is to regularly test the water for coliform bacteria. Coliform bacteria are organisms that are present in the environment and in the feces of all warm-blooded animals and humans. Coliform bacteria will not likely cause illness. However, their presence in drinking water indicates that disease-causing organisms (pathogens) could be in the water system. Most pathogens that can contaminate water supplies come from the feces of humans or animals. Testing drinking water for all possible pathogens is complex, time-consuming, and expensive. It is relatively easy and inexpensive to test for coliform bacteria. If coliform bacteria are found in a water sample, water system operators work to find the source of contamination and restore safe drinking water. There are three different groups of coliform bacteria; each has a different level of risk.

COLIFORM TESTING: The effectiveness of disinfection is usually determined by Coliform bacteria testing. A positive sample is a bad thing and indicates that you have bacteria contamination.

COLLOIDAL SUSPENSIONS: Because both iron and manganese react with dissolved oxygen to form insoluble compounds, they are not found in high concentrations in waters containing dissolved oxygen except as colloidal suspensions of the oxide.

COLORIMETRIC MEASUREMENT: A means of measuring an unknown chemical concentration in water by measuring a sample's color intensity.

COMMUTATOR: A device for reversing the direction of a current. (in a DC motor or generator) a cylindrical ring or disk assembly of conducting members, individually insulated in a supporting structure with an exposed surface for contact with current-collecting brushes and mounted on the armature shaft, for changing the frequency or direction of the current in the armature windings.

CHRONIC: A stimulus that lingers or continues for a relatively long period of time, often one-tenth of the life span or more. Chronic should be considered a relative term depending on the life span of an organism. The measurement of chronic effect can be reduced growth, reduced reproduction, etc., in addition to lethality.

COMBINED CHLORINE: The reaction product of chlorine with ammonia or other pollutants, also known as chloramines.

COMMUNITY WATER SYSTEM: A water system which supplies drinking water to 25 or more of the same people year-round in their residences.

COMPLIANCE CYCLE: A 9-calendar year time-frame during which a public water system is required to monitor. Each compliance cycle consists of 3 compliance periods.

COMPLIANCE PERIOD: A 3-calendar year time-frame within a compliance cycle.

COMPLETION (WELL COMPLETION): Refers to the final construction of the well including the installation of pumping equipment.

COMPOSITE SAMPLE: A water sample that is a combination of a group of samples collected at various intervals during the day.

CONDENSATION: The process that changes water vapor to tiny droplets or ice crystals.

CONE OF DEPRESSION: That portion of the water table or potentiometric surface that experiences drawdown from a pumped well.

CONFINED AQUIFER: An aquifer that is isolated by confining layers on both its top and bottom. Pressures within a confined aquifer are normally greater than atmospheric pressure resulting in a potentiometric head.

CONFINING LAYER: An extensive layer of soil or formation that resists the movement of water from an aquifer below or above it. Confining layers isolate aquifers thereby confining them. May or may not be an aquiclude. (ex – Clay or silt rich layer)

CONSOLIDATED: Soil, sediment, or formation that is solidified or cemented together as a unit.

CONTACT TIME, pH and LOW TURBIDITY: Factors which are important in providing good disinfection using chlorine.

CONTACT TIME: If the water temperature decreases from 70°F (21°C) to 40°F (4°C). The operator needs to increase the detention time to maintain good disinfection of the water.

CONTAINS THE ELEMENT CARBON: A simple definition of an organic compound.

CONTAMINANT: Any natural or man-made physical, chemical, biological, or radiological substance or matter in water, which is at a level that may have an adverse effect on public health, and which is known or anticipated to occur in public water systems.

CONTAMINATE: tr.v. con-tam-i-nated, con-tam-i-nat-ing, con-tam-i-nates
1. To make impure or unclean by contact or mixture.
2. To expose to or permeate with radioactivity.

CONTAMINATION: A degradation in the quality of groundwater in result of the it's becoming polluted with unnatural or previously non-existent constituents.

CONTINUOUS SLOT SCREEN: A wire wrapped or plastic slotted screen in which the slot openings completely encircle the inner ribs of the screen.

CONTROL TASTE AND ODOR PROBLEMS: KMnO_4 Potassium permanganate is a strong oxidizer commonly used to control taste and odor problems.

CONVENTIONAL: A standard or common procedure to a group of more complex methods. (ex – Direct Rotary *conventional* vs. Reverse *non-conventional*)

COPPER: The chemical name for the symbol Cu.

CORROSION: The removal of metal from copper, other metal surfaces and concrete surfaces in a destructive manner. Corrosion is caused by improperly balanced water or excessive water velocity through piping or heat exchangers.

CORROSIVITY: The Langelier Index measures corrosivity.

COUPON: A coupon placed to measure corrosion damage in the water mains.

CROSS-CONNECTION: A physical connection between a public water system and any source of water or other substance that may lead to contamination of the water provided by the public water system through backflow. Might be the source of an organic substance causing taste and odor problems in a water distribution system.

CROSS-CONTAMINATION: The mixing of two unlike qualities of water. For example, the mixing of good water with a polluting substance like a chemical.

CUTTING HEAD (CUTTER HEAD): The bit portion of auger flighting that serves as the primary cutting edge of the auger.

CUTTING SHOE: A hardened steel sleeve with a wedged or armored cutting edge that is installed on well casing that is to be driven into the earth.

CUTTINGS: Crushed rock, soil, or formation material generated by the drilling action of a bit.

CRYPTOSPORIDIUM: A disease-causing parasite, resistant to chlorine disinfection. It may be found in fecal matter or contaminated drinking water. Cryptosporidium is a protozoan pathogen of the Phylum Apicomplexa and causes a diarrheal illness called cryptosporidiosis. Other apicomplexan pathogens include the malaria parasite Plasmodium, and Toxoplasma, the causative agent of toxoplasmosis. Unlike Plasmodium, which transmits via a mosquito vector, Cryptosporidium does not utilize an insect vector and is capable of completing its life cycle within a single host, resulting in cyst stages which are excreted in feces and are capable of transmission to a new host.

CYANURIC ACID: White, crystalline, water-soluble solid, $\text{C}_3\text{H}_3\text{O}_3\text{N}_3 \cdot 2\text{H}_2\text{O}$, used chiefly in organic synthesis. Chemical used to prevent the decomposition of chlorine by ultraviolet (UV) light.

CYANOBACTERIA: Cyanobacteria, also known as blue-green algae, blue-green bacteria or Cyanophyta, is a phylum of bacteria that obtain their energy through photosynthesis. The name "cyanobacteria" comes from the color of the bacteria (Greek: kyanós = blue). They are a significant component of the marine nitrogen cycle and an important primary producer in many areas of the ocean, but are also found on land.

DAILY MAXIMUM LIMITATIONS: The maximum allowable discharge of pollutants during a 24 hour period. Where daily maximum limitations are expressed in units of mass, the daily discharge is the total mass discharged over the course of the day. Where daily maximum limitations are expressed in terms of a concentration, the daily discharge is the arithmetic average measurement of the pollutant concentration derived from all measurements taken that day.

DANGEROUS CHEMICALS: The most suitable protection when working with a chemical that produces dangerous fumes is to work under an air hood or fume hood.

DARCY'S LAW: ($Q=KIA$) A fundamental equation used in the groundwater sciences to determine aquifer characteristics, where Q =Flux, K =Hydraulic Conductivity (Permeability), I = Hydraulic Gradient (change in head), and A = Cross Sectional Area of flow.

DECIBELS: The unit of measurement for sound.

DECOMPOSE: To decay or rot.

DECOMPOSITION OF ORGANIC MATERIAL: The decomposition of organic material in water produces taste and odors.

DEMINERALIZATION PROCESS: Mineral concentration of the feed water is the most important consideration in the selection of a demineralization process. Acid feed is the most common method of scale control in a membrane demineralization treatment system.

DENTAL CARIES PREVENTION IN CHILDREN: The main reason that fluoride is added to a water supply.

DEPOLARIZATION: The removal of hydrogen from a cathode.

DESICCANT: When shutting down equipment which may be damaged by moisture, the unit may be protected by sealing it in a tight container. This container should contain a desiccant.

DESORPTION: Desorption is a phenomenon whereby a substance is released from or through a surface. The process is the opposite of sorption (that is, adsorption and absorption). This occurs in a system being in the state of sorption equilibrium between bulk phase (fluid, i.e. gas or liquid solution) and an adsorbing surface (solid or boundary separating two fluids). When the concentration (or pressure) of substance in the bulk phase is lowered, some of the sorbed substance changes to the bulk state. In chemistry, especially chromatography, desorption is the ability for a chemical to move with the mobile phase. The more a chemical desorbs, the less likely it will adsorb, thus instead of sticking to the stationary phase, the chemical moves up with the solvent front. In chemical separation processes, stripping is also referred to as desorption as one component of a liquid stream moves by mass transfer into a vapor phase through the liquid-vapor interface.

DEVELOPMENT: The cleaning of the well and bore once construction is complete.

DETENTION LAG: Is the period of time between the moment of change in a chlorinator control system and the moment when the change is sensed by the chlorine residual indicator.

DETENTION LAG TIME: The minimum detention time range recommended for flocculation is 5 – 20 minutes for direct filtration and up to 30 minutes for conventional filtration.

DIATOMACEOUS EARTH: A fine silica material containing the skeletal remains of algae.

DIRECT CURRENT: A source of direct current (**DC**) may be used for standby lighting in a water treatment facility. The electrical current used in a DC system may come from a battery.

DIRECT ROTARY: The conventional method of rotary drilling involving the rotation of a drill string and standard use of drilling fluid to penetrate the earth.

DISCHARGE HEAD: See Total Dynamic Head.

DISINFECT: The application of a chemical to kill most, but not all, microorganisms that may be present. Chlorine is added to public water drinking systems drinking water for disinfection. Depending on your state rule, drinking water must contain a minimum of 0.2 mg/L free chlorine. Disinfection makes drinking water safe to consume from the standpoint of killing pathogenic microorganisms including bacteria and viruses. Disinfection does not remove all bacteria from drinking water, but the bacteria that can survive disinfection with chlorine are not pathogenic bacteria that can cause disease in normal healthy humans.

DISINFECTION: The treatment of water to inactivate, destroy, and/or remove pathogenic bacteria, viruses, protozoa, and other parasites.

DISINFECTION BY-PRODUCTS (DBPs): The products created due to the reaction of chlorine with organic materials (e.g. leaves, soil) present in raw water during the water treatment process. The EPA has determined that these DBPs can cause cancer. Chlorine is added to drinking water to kill or inactivate harmful organisms that cause various diseases. This process is called disinfection. However, chlorine is a very active substance and it reacts with naturally occurring substances to form compounds known as disinfection byproducts (DBPs). The most common DBPs formed when chlorine is used are trihalomethanes (THMs), and haloacetic acids (HAAs).

DISSOLVED OXYGEN: Can be added to zones within a lake or reservoir that would normally become anaerobic during periods of thermal stratification.

DISSOLUTION : The chemical and physical process of dissolving rock. Typically, limestone or carbonate rocks can be dissolved via the percolation or movement of groundwater that, in its infancy, is slightly acidic. As time goes on, the rock may also be physically worn away by the rapid movement of groundwater through the interconnected open spaces created by the initial chemical dissolving process.

DISTILLATION, REVERSE OSMOSIS AND FREEZING: Processes that can be used to remove minerals from the water.

DRAG BIT: A style of drill bit used in rotary drilling when soil or formation conditions are loosely consolidated and are comprised of fine-grained sediments.

DRAWDOWN: The change in water level from static to pumping level.

DRILL COLLAR: A section of the drill string that provides sufficient mass and diameter to maintain vertical borehole alignment and consistent borehole diameter.

DRILL FOAM: Surfactant used in air rotary drilling and well development.

DRILL PIPE: Sections of the drill string that are connected one to another in order to achieve a desired length while also providing a pathway for the circulation of drilling fluid.

DRILL STEM: The complete drill string or, in cable drilling, the equivalent of a drill collar.

DRILL STRING: The complete drilling assembly in rotary drilling including drill pipe, subs, collars, and bit.

DRILLER: A specially trained individual that operates the drilling rig.

DRILLING FLUID: Fluid circulated through the borehole in rotary drilling methods used to lift cuttings to the surface, provide borehole stability, and cool the bit. Drilling Fluid may consist of mud, water, air, foam, or other additives.

DRILLING PERMIT: A certificate of approval to drill and construct a well often required by the state or local regulating authority.

DRILLING PRESSURE: The pressure exerted within the borehole during drilling. The pressure required to circulate drilling fluid to the surface.

DRIVE BLOCK: A heavy collar that attaches over the drill pipe and is dropped successively to advance casing into the earth. Used primarily in cable tool or percussion drilling methods.

DRIVE CLAMP: A fitting that is attached to the top of a drill string or stem serving as a striking surface for driving casing into the earth.

DRIVE UNIT: The portion of a rotary rig that provides the rotation to the drill string. (ex – top drive or table drive unit). Also may be called the drive head.

DRIVING: The installation of a well or casing via forcing of it into the earth by repeated striking.

DRY ACID: A granular chemical used to lower pH and or total alkalinity.

E. COLI, *Escherichia coli*: A bacterium commonly found in the human intestine. For water quality analyses purposes, it is considered an indicator organism. These are considered evidence of water contamination. Indicator organisms may be accompanied by pathogens, but do not necessarily cause disease themselves.

EFFECTIVENESS OF CHLORINE: The factors which influence the effectiveness of chlorination the most are pH, turbidity and temperature. Effectiveness of Chlorine decreases occurs during disinfection in source water with excessive turbidity.

ELECTRON: The name of a negatively charged atomic particle.

ELEMENTARY BUSINESS PLAN: Technical Capacity, Managerial Capacity, and Financial Capacity make up the elementary business plan. To become a new public water system, an owner shall file an elementary business plan for review and approval by state environmental agency.

EMERGENCY RESPONSE TEAM: A local team that is thoroughly trained and equipped to deal with emergencies, e.g. chlorine gas leak. In case of a chlorine gas leak, get out of the area and notify your local emergency response team in case of a large uncontrolled chlorine leak.

ENHANCED COAGULATION: The process of joining together particles in water to help remove organic matter.

ENTAMOEBIA HISTOLYTICA: *Entamoeba histolytica*, another water-borne pathogen, can cause diarrhea or a more serious invasive liver abscess. When in contact with human cells, these amoebae are cytotoxic. There is a rapid influx of calcium into the contacted cell, it quickly stops all membrane movement save for some surface blebbing. Internal organization is disrupted, organelles lyse, and the cell dies. The ameba may eat the dead cell or just absorb nutrients released from the cell.

ENTEROVIRUS: A virus whose presence may indicate contaminated water; a virus that may infect the gastrointestinal tract of humans.

EUGLENA: Euglena are common protists, of the class Euglenoidea of the phylum Euglenophyta. Currently, over 1000 species of Euglena have been described. Marin et al. (2003) revised the genus so and including several species without chloroplasts, formerly classified as *Astasia* and *Khawkinea*. Euglena sometimes can be considered to have both plant and animal features. *Euglena gracilis* has a long hair-like thing that stretches from its body. You need a very powerful microscope to see it. This is called a flagellum, and the euglena uses it to swim. It also has a red eyespot. *Euglena gracilis* uses its eyespot to locate light. Without light, it cannot use its chloroplasts to make itself food.

EVOLUTION: Any process of formation or growth; development: the evolution of a language; the evolution of the airplane. A product of such development; something evolved: The exploration of space is the evolution of decades of research.

Biology. Change in the gene pool of a population from generation to generation by such processes as mutation, natural selection, and genetic drift. A process of gradual, peaceful, progressive change or development, as in social or economic structure or institutions, a motion incomplete in itself, but combining with coordinated motions to produce a single action, as in a machine. A pattern formed by or as if by a series of movements: the evolutions of a figure skater.

F: The chemical symbol of Fluorine.

FAUCET WITH AN AERATOR: When collecting a water sample from a distribution system, a faucet with an aerator should not be used as a sample location.

FAULT: A break in the earth's crust where movement has occurred.

FAULTING: A geological process involving the breaking and displacement of rock or formation through movements within the earth's crust along a fault.

FECAL COLIFORM: A group of bacteria that may indicate the presence of human or animal fecal matter in water. Total coliform, fecal coliform, and E. coli are all indicators of drinking water quality. The total coliform group is a large collection of different kinds of bacteria. Fecal coliforms are types of total coliform that mostly exist in feces. E. coli is a sub-group of fecal coliform. When a water sample is sent to a lab, it is tested for total coliform. If total coliform is present, the sample will also be tested for either fecal coliform or E. coli, depending on the lab testing method.

FILTRATION: The process of passing water through materials with very small holes to strain out particles. Most conventional water treatment plants used filters composed of gravel, sand, and anthracite. These materials settle into a compact mass that forms very small holes. Particles are filtered out as treated water passes through these holes. These holes are small enough to remove microorganisms including algae, bacteria, and protozoans, but not viruses. Viruses are eliminated from drinking water through the process of disinfection using chlorine. A series of processes that physically removes particles from water. A water treatment step used to remove turbidity, dissolved organics, odor, taste and color.

FILTER CLOGGING: An inability to meet demand may occur when filters are clogging.

FILTRATION METHODS: The conventional type of water treatment filtration method includes coagulation, flocculation, sedimentation, and filtration. Direct filtration method is similar to conventional except that the sedimentation step is omitted. Slow sand filtration process does not require pretreatment, has a flow of 0.1 gallons per minute per square foot of filter surface area, and is simple to operate and maintain. The Diatomaceous earth method uses a thin layer of fine siliceous material on a porous plate. This type of filtration medium is only used for water with low turbidity. Sedimentation, adsorption, and biological action treatment methods are filtration processes that involve a number of interrelated removal mechanisms. Demineralization is primarily used to remove total dissolved solids from industrial wastewater, municipal water, and seawater.

FINISHED WATER: Treated drinking water that meets minimum state and federal drinking water regulations.

FLIGHTING: The spiral flanged drill pipe used in auger drilling.

FLOATING SUB: A collapsible section of drill pipe shorter than primary drill pipe. Used to provide a cushion between the drive unit and the drill string.

FLOCCULATION: The process of bringing together destabilized or coagulated particles to form larger masses that can be settled and/or filtered out of the water being treated. Conventional coagulation–flocculation–sedimentation practices are essential pretreatments for many water purification systems—especially filtration treatments. These processes agglomerate suspended solids together into larger bodies so that physical filtration processes can more easily remove them. Particulate removal by these methods makes later filtering processes far more effective. The process is often followed by gravity separation (sedimentation or flotation) and is always followed by filtration. A chemical coagulant, such as iron salts, aluminum salts, or polymers, is added to source water to facilitate bonding among particulates. Coagulants work by creating a chemical reaction and eliminating the negative charges that cause particles to repel each other. The coagulant-source water mixture is then slowly stirred in a process known as flocculation. This water churning induces particles to collide and clump together into larger and more easily removable clots, or “flocs.” The process requires chemical knowledge of source water characteristics to ensure that an effective coagulant mix is employed. Improper coagulants make these treatment methods ineffective. The ultimate effectiveness of coagulation/flocculation is also determined by the efficiency of the filtering process with which it is paired.

FLOCCULANTS: Flocculants, or flocculating agents, are chemicals that promote flocculation by causing colloids and other suspended particles in liquids to aggregate, forming a floc. Flocculants are used in water treatment processes to improve the sedimentation or filterability of small particles. For example, a flocculant may be used in swimming pool or drinking water filtration to aid removal of microscopic particles which would otherwise cause the water to be cloudy and which would be difficult or impossible to remove by filtration alone. Many flocculants are multivalent cations such as aluminum, iron, calcium or magnesium. These positively charged molecules interact with negatively charged particles and molecules to reduce the barriers to aggregation. In addition, many of these chemicals, under appropriate pH and other conditions such as temperature and salinity, react with water to form insoluble hydroxides which, upon precipitating, link together to form long chains or meshes, physically trapping small particles into the larger floc.

Long-chain polymer flocculants, such as modified polyacrylamides, are manufactured and sold by the flocculant producing business. These can be supplied in dry or liquid form for use in the flocculation process. The most common liquid polyacrylamide is supplied as an emulsion with 10-40 % actives and the rest is a carrier fluid, surfactants and latex. Emulsion polymers require activation to invert the emulsion and allow the electrolyte groups to be exposed.

FLOC SHEARING: Likely to happen to large floc particles when they reach the flocculation process.

FLOCCULATION BASIN: A compartmentalized basin with a reduction of speed in each compartment. This set-up or basin will give the best overall results.

FLOOD RIM: The point of an object where the water would run over the edge of something and begin to cause a flood.

FLOW MUST BE MEASURED: A recorder that measures flow is most likely to be located in a central location.

FLUORIDE: High levels of fluoride may stain the teeth of humans. This is called Mottling. This chemical must not be overfed due to a possible exposure to a high concentration of the chemical. The most important safety considerations to know about fluoride chemicals are that all fluoride chemicals are extremely corrosive. These are the substances most commonly used to furnish fluoride ions to water: Sodium fluoride, Sodium silicofluoride and Hydrofluosilicic acid.

FLUORIDE FEEDING: Always review fluoride feeding system designs and specifications to determine whether locations for monitoring readouts and dosage controls are convenient to the operation center and easy to read and correct.

FLUX: The term flux describes the rate of water flow through a semipermeable membrane. When the water flux decreases through a semipermeable membrane, it means that the mineral concentration of the water is increasing.

FORMATION: A series of layers, deposits, or bodies of rock, which are geologically similar and related in depositional environment or origin. A formation can be clearly distinguished relative to bounding deposits or formations due to its particular characteristics and composition.

FORMATION OF TUBERCLES: This condition is of the most concern regarding corrosive water effects on a water system. It is the creation of mounds of rust inside the water lines.

FRACTURE: A discrete break in a rock or formation.

FRACTURED AQUIFER: An aquifer within and otherwise massive block that has been made permeable due to the concentrated presence of fractures typically resultant of faulting or concentrated joints.

FREE CHLORINE: In disinfection, chlorine is used in the form of free chlorine or as hypochlorite ion.

FREE CHLORINE RESIDUAL: Regardless of whether pre-chlorination is practiced or not, a free chlorine residual of at least 10 mg/L should be maintained in the clear well or distribution reservoir immediately downstream from the point of post-chlorination. The reason for chlorinating past the breakpoint is to provide protection in case of backflow.

GATE VALVE: The most common type of valve used in isolating a small or medium sized section of a distribution system and is the only linear valve used in water distribution. All the other valves are in the rotary classification.

GIARDIA LAMBLIA: Giardia lamblia (synonymous with Lamblia intestinalis and Giardia duodenalis) is a flagellated protozoan parasite that colonizes and reproduces in the small intestine, causing giardiasis. The giardia parasite attaches to the epithelium by a ventral adhesive disc, and reproduces via binary fission. Giardiasis does not spread via the bloodstream, nor does it spread to other parts of the gastrointestinal tract, but remains confined to the lumen of the small intestine. Giardia trophozoites absorb their nutrients from the lumen of the small intestine, and are anaerobes.

GIARDIASIS, HEPATITIS OR TYPHOID: Diseases that may be transmitted through the contamination of a water supply but not AIDS.

GIS – GRAPHIC INFORMATION SYSTEM: Detailed information about the physical locations of structures such as pipes, valves, and manholes within geographic areas with the use of satellites.

GEOTECHNICAL: Characteristics of soil, rock, or formation such as grain size, shear strength, porosity, and compressibility, etc. Of particular concern to a geologist or engineer relative to soil or aquifer characteristics.

GLOBE VALVE: The main difference between a globe valve and a gate valve is that a globe valve is designed as a controlling device.

GOOD CONTACT TIME, pH and LOW TURBIDITY: These are factors that are important in providing good disinfection when using chlorine.

GPM: Gallons per minute.

GRAB SAMPLE: A sample which is taken from a water or wastestream on a one-time basis with no regard to the flow of the water or wastestream and without consideration of time. A single grab sample should be taken over a period of time not to exceed 15 minutes.

GRAINSIZE: The dimension of particle classifications such as gravel, sand, silt, and clay. Often based on the unified soil classification system.

GROUNDWATER: Water that percolates through and exists within saturated portions of the earth's crust and is replenished by the hydrologic cycle.

GROUT: A type of cement that is normally fine grained and used to effectively construct well seals and used in well abandonment. Grout may also be used to stabilize otherwise unstable boreholes, permitting continued drilling.

GT: Represents (Detention time) x (mixing intensity) in flocculation.

H₂SO₄: The molecular formula of Sulfuric acid.

HALIDES: A halide is a binary compound, of which one part is a halogen atom and the other part is an element or radical that is less electronegative than the halogen, to make a fluoride, chloride, bromide, iodide, or astatide compound. Many salts are halides. All Group 1 metals form halides with the halogens and they are white solids. A halide ion is a halogen atom bearing a negative charge. The halide anions are fluoride (F), chloride (Cl), bromide (Br), iodide (I) and astatide (At). Such ions are present in all ionic halide salts.

HALL EFFECT: Refers to the potential difference (Hall voltage) on the opposite sides of an electrical conductor through which an electric current is flowing, created by a magnetic field applied perpendicular to the current. Edwin Hall discovered this effect in 1879.

HALOACETIC ACIDS: Haloacetic acids are carboxylic acids in which a halogen atom takes the place of a hydrogen atom in acetic acid. Thus, in a monohaloacetic acid, a single halogen would replace a hydrogen atom. For example, chloroacetic acid would have the structural formula $\text{CH}_2\text{ClCO}_2\text{H}$. In the same manner, in dichloroacetic acid two chlorine atoms would take the place of two hydrogen atoms ($\text{CHCl}_2\text{CO}_2\text{H}$).

HAMMER BIT: The bit driven by the hammer to cut into rock or formation.

HAMMER: See Air Hammer

HARD ROCK: Consolidated formation or solid rock.

HARD WATER: Hard water causes a buildup of scale in household hot water heaters. Hard water is a type of water that has high mineral content (in contrast with soft water). Hard water primarily consists of calcium (Ca^{2+}), and magnesium (Mg^{2+}) metal cations, and sometimes other dissolved compounds such as bicarbonates and sulfates. Calcium usually enters the water as either calcium carbonate (CaCO_3), in the form of limestone and chalk, or calcium sulfate (CaSO_4), in the form of other mineral deposits. The predominant source of magnesium is dolomite ($\text{CaMg}(\text{CO}_3)_2$). Hard water is generally not harmful. The simplest way to determine the hardness of water is the lather/froth test: soap or toothpaste, when agitated, lathers easily in soft water but not in hard water. More exact measurements of hardness can be obtained through a wet titration. The total water 'hardness' (including both Ca^{2+} and Mg^{2+} ions) is read as parts per million or weight/volume (mg/L) of calcium carbonate (CaCO_3) in the water. Although water hardness usually only measures the total concentrations of calcium and magnesium (the two most prevalent, divalent metal ions), iron, aluminum, and manganese may also be present at elevated levels in some geographical locations.

HARDNESS: A measure of the amount of calcium and magnesium salts in water. More calcium and magnesium lead to greater hardness. The term "hardness" comes from the fact that it is hard to get soap suds from soap or detergents in hard water. This happens because calcium and magnesium react strongly with negatively-charged chemicals like soap to form insoluble compounds.

HARTSHORN: The antler of a hart, formerly used as a source of ammonia. Ammonium carbonate.

HAZARDS OF POLYMERS: Slippery and difficult to clean-up are the most common hazards associated with the use of polymers in a water treatment plant.

HEAD: The measure of the pressure of water expressed in feet of height of water. 1 PSI = 2.31 feet of water or 1 foot of head equals about a half a pound of pressure or .433 PSI. There are various types of heads of water depending upon what is being measured. Static (water at rest) and Residual (water at flow conditions).

HEADWORKS: The facility at the "head" of the water source where water is first treated and routed into the distribution system.

HEALTH ADVISORY: An EPA document that provides guidance and information on contaminants that can affect human health and that may occur in drinking water, but which the EPA does not currently regulate in drinking water.

HERTZ: The term used to describe the frequency of cycles in an alternating current (AC) circuit.

HETEROTROPHIC PLATE COUNT: A test performed on drinking water to determine the total number of all types of bacteria in the water.

HF: The molecular formula of Hydrofluoric acid.

HIGH TURBIDITY CAUSING INCREASED CHLORINE DEMAND: May occur or be caused by the inadequate disinfection of water.

HOLLOW STEM (AUGER): An auger form of drilling in which the flighting is hollow.

HOLLOW STEM FLIGHT: The hollow spiral flanged drill pipe used on hollow stem auger rigs.

HOMOPOLAR: Of uniform polarity; not separated or changed into ions; not polar in activity. Electricity. unipolar.

HYDRAULIC CONDUCTIVITY: A primary factor in Darcy's Law, the measure of a soil or formations ability to transmit water, measured in gallons per day (gpd) See also Permeability and Darcy's Law.

HYDRIDES: Hydride is the name given to the negative ion of hydrogen, H. Although this ion does not exist except in extraordinary conditions, the term hydride is widely applied to describe compounds of hydrogen with other elements, particularly those of groups 1–16. The variety of compounds formed by hydrogen is vast, arguably greater than that of any other element. Various metal hydrides are currently being studied for use as a means of hydrogen storage in fuel cell-powered electric cars and batteries. They also have important uses in organic chemistry as powerful reducing agents, and many promising uses in hydrogen economy.

HYDROCHLORIC AND HYPOCHLOROUS ACIDS: HCL and HOCL The compounds that are formed in water when chlorine gas is introduced.

HYDROFLUOSILIC ACID: (H_2SiF_6) a clear, fuming corrosive liquid with a pH ranging from 1 to 1.5. Used in water treatment to fluoridate drinking water.

HYDROGEN SULFIDE OR CHLORINE GAS: These chemicals can cause olfactory fatigue.

HYDROLOGIC CYCLE: (Water Cycle) The continual process of precipitation (rain and snowfall), evaporation (primarily from the oceans), pecculation (recharge to groundwater), runoff (surface water), and transpiration (plants) constituting the renew ability and recycling of each component.

HYDROPHOBIC: Does not mix readily with water.

HYGROSCOPIC: Absorbing or attracting moisture from the air.

HYPOCHLORITE (OCL-) AND ORGANIC MATERIALS: Heat and possibly fire may occur when hypochlorite is brought into contact with an organic material.

HYPOLIMNION: The layer of water in a thermally stratified lake that lies below the thermocline, is noncirculating, and remains perpetually cold.

IMPELLERS: The semi-open or closed props or blades of a turbine pump that when rotated generate the pumping force.

IMPERVIOUS: Not allowing, or allowing only with great difficulty, the movement of water.

IN SERIES: Several components being connected one to the other without a bypass, requiring each component to work dependent on the one before it.

INFILTRATION: The percolation of fluid into soil or formation. See also percolation.

INFECTIOUS PATHOGENS/MICROBES/GERMS: Are considered disease-producing bacteria, viruses and other microorganisms.

INFLATABLE PACKER: A rubber or fiber bladder device that is inflated to seal against either casing or borehole walls.

INFORMATION COLLECTION RULE: ICR EPA collected data required by the Information Collection Rule (May 14, 1996) to support future regulation of microbial contaminants, disinfectants, and disinfection byproducts. The rule was intended to provide EPA with information on chemical byproducts that form when disinfectants used for microbial control react with chemicals already present in source water (disinfection byproducts (DBPs)); disease-causing microorganisms (pathogens), including Cryptosporidium; and engineering data to control these contaminants.

INITIAL MONITORING YEAR: An initial monitoring year is the calendar year designated by the Department within a compliance period in which a public water system conducts initial monitoring at a point of entry.

INORGANIC CONTAMINANTS: Mineral-based compounds such as metals, nitrates, and asbestos. These contaminants are naturally-occurring in some water, but can also get into water through farming, chemical manufacturing, and other human activities. EPA has set legal limits on 15 inorganic contaminants.

INORGANIC IONS: Present in all waters. Inorganic ions are essential for human health in small quantities, but in larger quantities they can cause unpleasant taste and odor or even illness. Most community water systems will commonly test for the concentrations of seven inorganic ions: nitrate, nitrite, fluoride, phosphate, sulfate, chloride, and bromide. Nitrate and nitrite can cause an illness in infants called methemoglobinemia. Fluoride is actually added to the drinking water in some public water systems to promote dental health. Phosphate, sulfate, chloride, and bromide have little direct effect on health, but high concentrations of inorganic ions can give water a salty or briny taste.

INSOLUBLE COMPOUNDS: Are types of compounds cannot be dissolved. When iron or manganese reacts with dissolved oxygen (DO) insoluble compound are formed.

INTAKE FACILITIES: One of the more important considerations in the construction of intake facilities is the ease of operation and maintenance over the expected lifetime of the facility. Every intake structure must be constructed with consideration for operator safety and for cathodic protection.

ION EXCHANGE: An effective treatment process used to remove iron and manganese in a water supply. The hardness of the source water affects the amount of water an ion exchange softener may treat before the bed requires regeneration.

IRON: Fe The elements iron and manganese are undesirable in water because they cause stains and promote the growth of iron bacteria.

IRON AND MANGANESE: Fe and Mn In water they can usually be detected by observing the color of the inside walls of filters and the filter media. If the raw water is pre-chlorinated, there will be black stains on the walls below the water level and a black coating over the top portion of the sand filter bed. When significant levels of dissolved oxygen are present, iron and manganese exist in an oxidized state and normally precipitate into the reservoir bottom sediments. The presence of iron and manganese in water promote the growth of Iron bacteria. Only when a water sample has been acidified then you can perform the analysis beyond the 48 hour holding time. Iron and Manganese in water may be detected by observing the color of the of the filter media. Maintaining a free chlorine residual and regular flushing of water mains may control the growth of iron bacteria in a water distribution system.

IRON BACTERIA: Perhaps the most troublesome consequence of iron and manganese in the water is they promote the growth of a group of microorganism known as Iron Bacteria.

IRON FOULING: You should look for an orange color on the resin and backwash water when checking an ion exchange unit for iron fouling

JARS (DRILLING JARS): Metal sections of a drill string that when released provide a jarring force or action to aid in removing drill string. Used primarily in cable tool or percussion drilling methods.

JETTING: The process of injecting high velocity streams of water and/or air through a system of nozzles or jets into the well screen and filter pack for well development.

KARST TOPOGRAPHY: The visual presence of karst on the surface.

KARST: The presence of caverns, voids, sink holes as characteristic features of a weathered limestone or other carbonate formation on or beneath the surface.

KELLY: A multi-faceted section of drill pipe driven by a kelly drive (table or top drive).

KILL = C X T: Where other factors are constant, the disinfecting action may be represented by: Kill=C x T. C= Chlorine T= Contact time.

KINETIC ENERGY: The ability of an object to do work by virtue of its motion. The energy terms that are used to describe the operation of a pump are pressure and head.

LACRIMATION: The secretion of tears, esp. in abnormal abundance Also, lachrymation, lachrimation.

LANGELIER INDEX: A measurement of Corrosivity. The water is becoming corrosive in the distribution system causing rusty water if the Langelier index indicates that the pH has decreased from the equilibrium point. Mathematically derived factor obtained from the values of calcium hardness, total alkalinity, and pH at a given temperature. A Langelier index of zero indicates perfect water balance (i.e., neither corroding nor scaling). The Langelier Saturation Index (sometimes Langelier Stability Index) is a calculated number used to predict the calcium carbonate stability of water. It indicates whether the water will precipitate, dissolve, or be in equilibrium with calcium carbonate. Langelier developed a method for predicting the pH at which water is saturated in calcium carbonate (called pHs). The LSI is expressed as the difference between the actual system pH and the saturation pH.
 $LSI = pH - pHs$

LEACHING: A chemical reaction between water and metals that allows for removal of soluble materials.

LEAD AND COPPER: Initial tap water monitoring for lead and copper must be conducted during 2 consecutive 6-month periods.

LIME: Is a chemical that may be added to water to reduce the corrosivity. When an operator adds lime to water, Calcium and magnesium become less soluble.

LIME SODA SOFTENING: In a lime soda softening process, the pH of the water is raised to 11.0. In a lime softening process, excess lime is frequently added to remove Calcium and Magnesium Bicarbonate. The minimum hardness which can be achieved by the lime-soda ash process is 30 to 40 mg/L as calcium carbonate. The hardness due to noncarbonate hardness is most likely to determine the choice between lime softening and ion exchange to remove hardness.

LIME SOFTENING: Lime softening is primarily used to “soften” water—that is to remove calcium and magnesium mineral salts. But it also removes harmful toxins like radon and arsenic. Though there is no consensus, some studies have even suggested that lime softening is effective at removal of Giardia. Hard water is a common condition responsible for numerous problems. Users often recognize hard water because it prevents their soap from lathering properly. However, it can also cause buildup (“scale”) in hot water heaters, boilers, and hot water pipes. Because of these inconveniences, many treatment facilities use lime softening to soften hard water for consumer use. Before lime softening can be used, managers must determine the softening chemistry required. This is a relatively easy task for groundwater sources, which remain more constant in their composition. Surface waters, however, fluctuate widely in quality and may require frequent changes to the softening chemical mix. In lime softening, lime and sometimes sodium carbonate are added to the water as it enters a combination solids contact clarifier. This raises the pH (i.e., increases alkalinity) and leads to the precipitation of calcium carbonate. Later, the pH of the effluent from the clarifier is reduced again, and the water is then filtered through a granular media filter. The water chemistry requirements of these systems require knowledgeable operators, which may make lime softening an economic challenge for some very small systems.

LINE SHAFT TURBINE: See vertical turbine.

LOGGED (LOGGING): The assessment and documentation of geological and water production data obtained while drilling progresses or following drilling through the use of borehole geophysical logging tools.

L.O.T.O.: Lock Out, Tag Out. If a piece of equipment is locked out, the key to the lock-out device the key should be held by the person who is working on the equipment. The tag is an identification device and the lock is a physical restraint.

M-ENDO BROTH: The coliform group is used as indicators of fecal pollution in water, for assessing the effectiveness of water treatment and disinfection, and for monitoring water quality. m-Endo Broth is used for selectively isolating coliform bacteria from water and other specimens using the membrane filtration technique. m-Endo Broth is prepared according to the formula of Fifield and Schaufus.¹ It is recommended by the American Public Health Association in standard total coliform membrane filtration procedure for testing water, wastewater, and foods.^{2,3} The US EPA specifies using m-Endo Broth in the total coliform methods for testing water using single-step, two-step, and delayed incubation membrane filtration methods.

MAGNESIUM HARDNESS: Measure of the magnesium salts dissolved in water – it is not a factor in water balance.

MAGNETIC STARTER: Is a type of motor starter should be used in an integrated circuit to control flow automatically.

MARBLE AND LANGELIER TESTS: Are used to measure or determine the corrosiveness of a water source.

MAXIMUM CONTAMINANT LEVEL (MCLs): The maximum allowable level of a contaminant that federal or state regulations allow in a public water system. If the MCL is exceeded, the water system must treat the water so that it meets the MCL.

MAXIMUM CONTAMINANT LEVEL GOAL (MCLG): The level of a contaminant at which there would be no risk to human health. This goal is not always economically or technologically feasible, and the goal is not legally enforceable.

MCL for TURBIDITY: Turbidity is undesirable because it causes health hazards. An MCL for turbidity was established by the EPA because turbidity does not allow for proper disinfection.

MEASURE CORROSION DAMAGE: A coupon such as a strip of metal and is placed to measure corrosion damage in the distribution system in a water main.

MECHANICAL SEAL: A mechanical device used to control leakage from the stuffing box of a pump. Usually made of two flat surfaces, one of which rotates on the shaft. The two flat surfaces are of such tolerances as to prevent the passage of water between them. Held in place with spring pressure.

MEDIUM WATER SYSTEM: More than 3,300 persons and 50,000 or fewer persons.

MEGGER: Is a portable instrument used to measure insulation resistance. The megger consists of a hand-driven DC generator and a direct reading ohm meter. Used to test the insulation resistance on a motor.

M-ENDO BROTH: The media shall be brought to the boiling point when preparing M-Endo broth to be used in the membrane filter test for total coliform.

METALIMNION: Thermocline, middle layer of a thermally stratified lake which is characterized by a rapid decrease in temperature in proportion to depth.

METALLOID: Metalloid is a term used in chemistry when classifying the chemical elements. On the basis of their general physical and chemical properties, nearly every element in the periodic table can be termed either a metal or a nonmetal. A few elements with intermediate properties are, however, referred to as metalloids. (In Greek metallon = metal and eidos = sort)

METHANE: Methane is a chemical compound with the molecular formula CH₄. It is the simplest alkane, and the principal component of natural gas. Methane's bond angles are 109.5 degrees. Burning methane in the presence of oxygen produces carbon dioxide and water. The relative abundance of methane and its clean burning process makes it a very attractive fuel. However, because it is a gas at normal temperature and pressure, methane is difficult to transport from its source. In its natural gas form, it is generally transported in bulk by pipeline or LNG carriers; few countries still transport it by truck.

MILLILITER: One one-thousandth of a liter; A liter is a little more than a quart. A milliliter is about two drops from an eye dropper.

Mg/L: Stands for "milligrams per liter." A common unit of chemical concentration. It expresses the mass of a chemical that is present in a given volume of water. A milligram (one one-thousandth of a gram) is equivalent to about 18 grains of table salt. A liter is equivalent to about one quart.

MICROBIOLOGICAL: Is a type of analysis in which a composite sample unacceptable.

MICROBE OR MICROBIAL: Any minute, simple, single-celled form of life, especially one that causes disease.

MICROBIAL CONTAMINANTS: Microscopic organisms present in untreated water that can cause waterborne diseases.

MICROORGANISMS: Very small animals and plants that are too small to be seen by the naked eye and must be observed using a microscope. Microorganisms in water include algae, bacteria, viruses, and protozoa. Algae growing in surface waters can cause off-taste and odor by producing the chemicals MIB and geosmin. Certain types of bacteria, viruses, and protozoa can cause disease in humans. Bacteria are the most common microorganisms found in treated drinking water. The great majority of bacteria are not harmful. In fact, humans would not be able to live without the bacteria that inhabit the intestines. However, certain types of bacteria called coliform bacteria can signal the presence of possible drinking water contamination.

MILLILITER: One one-thousandth of a liter. A liter is a little more than a quart. A milliliter is about two drops from an eye dropper.

MOISTURE: If a material is hygroscopic, it must be protected from water.

MOISTURE AND POTASSIUM PERMANGANATE: The combination of moisture and potassium permanganate produces heat.

MOLECULAR WEIGHT: The molecular mass (abbreviated Mr) of a substance, formerly also called molecular weight and abbreviated as MW, is the mass of one molecule of that substance, relative to the unified atomic mass unit u (equal to 1/12 the mass of one atom of carbon-12). This is distinct from the relative molecular mass of a molecule, which is the ratio of the mass of that molecule to 1/12 of the mass of carbon 12 and is a dimensionless number. Relative molecular mass is abbreviated to Mr.

MOTTLING: High levels of fluoride may stain the teeth of humans.

M.S.D.S.: Material Safety Data Sheet. A safety document must an employer provide to an operator upon request.

MUD BALLS IN FILTER MEDIA: Is a possible result of an ineffective or inadequate filter backwash.

MUD CAKE: A film of mud drilling fluid that builds up on borehole walls adding to borehole stability and limits the groundwater's ability to enter the borehole while drilling.

MUD CAKING: The process of building up the mud cake.

MUD ENGINEER: A specially trained individual who's responsible for maintaining proper drilling fluid densities and viscosity.

MUD PIT: Single or multiple subsurface or surface containment system used for settling cuttings out of drilling fluid and for recirculation of drilling fluid.

MUD PUMP: A specially designed pump that can pass particles of mud and cuttings (drilling fluid) at variable pressures, serving as the primary component in a mud rotary drilling system (similar to a grout or cement pump).

MUD ROTARY: The method of rotary drilling with mud circulation as the drilling fluid.

MURIATIC ACID: An acid used to reduce pH and alkalinity. Also used to remove stain and scale.

MYCOTOXIN: A toxin produced by a fungus.

NaOCl: Is the molecular formula of Sodium hypochlorite.

NaOH: Is the molecular formula of Sodium hydroxide.

NASCENT: Coming into existence; emerging.

NATURAL GRAVEL PACK (NATURALLY PACKED): Refers to a well that has no gravel pack installed but is simply allowed to develop a filter pack composed of the aquifer particles itself. Usually coarse grained and hard rock aquifers are naturally packed.

NH₃: The molecular formula of Ammonia.

NH₄⁺: The molecular formula of the Ammonium ion.

NITRATES: A dissolved form of nitrogen found in fertilizers and sewage by-products that may leach into groundwater and other water sources. Nitrates may also occur naturally in some waters. Over time, nitrates can accumulate in aquifers and contaminate groundwater.

NITROGEN: Nitrogen is a nonmetal, with an electronegativity of 3.0. It has five electrons in its outer shell and is therefore trivalent in most compounds. The triple bond in molecular nitrogen (N₂) is one of the strongest in nature. The resulting difficulty of converting (N₂) into other compounds, and the ease (and associated high energy release) of converting nitrogen compounds into elemental N₂, have dominated the role of nitrogen in both nature and human economic activities.

NITROGEN AND PHOSPHORUS: Pairs of elements and major plant nutrients that cause algae to grow.

NO₃⁻: The molecular formula of the Nitrate ion.

NON-CARBONATE HARDNESS: The portion of the total hardness in excess of the alkalinity.

NON-CARBONATE IONS: Water contains non-carbonate ions if it cannot be softened to a desired level through the use of lime only.

NON-POINT SOURCE POLLUTION: Air pollution may leave contaminants on highway surfaces. This non-point source pollution adversely impacts reservoir water and groundwater quality.

NON-TRANSIENT, NON-COMMUNITY WATER SYSTEM: A water system which supplies water to 25 or more of the same people at least six months per year in places other than their residences. Some examples are schools, factories, office buildings, and hospitals which have their own water systems.

NORMALITY: It is the number of equivalent weights of solute per liter of solution. Normality highlights the chemical nature of salts: in solution, salts dissociate into distinct reactive species (ions such as H⁺, Fe₃⁺, or Cl⁻). Normality accounts for any discrepancy between the concentrations of the various ionic species in a solution. For example, in a salt such as MgCl₂, there are two moles of Cl⁻ for every mole of Mg₂⁺, so the concentration of Cl⁻ as well as of Mg₂⁺ is said to be 2 N (read: "two normal"). Further examples are given below. A normal is one gram equivalent of a solute per liter of solution. The definition of a gram equivalent varies depending on the type of chemical reaction that is discussed - it can refer to acids, bases, redox species, and ions that will precipitate. It is critical to note that normality measures a single ion which takes part in an overall solute. For example, one could determine the normality of hydroxide or sodium in an aqueous solution of sodium hydroxide, but the normality of sodium hydroxide itself has no meaning. Nevertheless it is often used to describe solutions of acids or bases, in those cases it is implied that the normality refers to the H⁺ or OH⁻ ion. For example, 2 Normal sulfuric acid (H₂SO₄), means that the normality of H⁺ ions is 2, or that the molarity of the sulfuric acid is 1. Similarly for 1 Molar H₃PO₄ the normality is 3 as it contains three H⁺ ions.

NTNCWS: Non-transient non-community water system.

NTU (Nephelometric turbidity unit): A measure of the clarity or cloudiness of water.

O₃: The molecular formula of ozone.

OIL TUBE: A tubular enclosure that houses the line shaft and bearings of a vertical turbine pump. Oil is allowed to pass through the oil tube in order to lubricate the pumps drive shaft and bearings.

OLIGOTROPHIC: A reservoir that is nutrient-poor and contains little plant or animal life. An oligotrophic ecosystem or environment is one that offers little to sustain life. The term is commonly utilized to describe bodies of water or soils with very low nutrient levels. It derives etymologically from the Greek oligo (small, little, few) and trophe (nutrients, food). Oligotrophic environments are of special interest for the alternative energy sources and survival strategies upon which life could rely.

ORGANIC PRESURSORS: Natural or man-made compounds with chemical structures based upon carbon that, upon combination with chlorine, leading to trihalomethane formation.

OSMOSIS: Osmosis is the process by which water moves across a semi permeable membrane from a low concentration solute to a high concentration solute to satisfy the pressure differences caused by the solute.

OVERBURDEN: Normally a thin loosely consolidated or unconsolidated sediment overlying competent formation.

OVER-RANGE PROTECTION DEVICES: Mechanical dampers, snubbers and an air cushion chamber are examples of surging and overrange protection devices.

OXIDE: An oxide is a chemical compound containing at least one oxygen atom as well as at least one other element. Most of the Earth's crust consists of oxides. Oxides result when elements are oxidized by oxygen in air. Combustion of hydrocarbons affords the two principal oxides of carbon, carbon monoxide and carbon dioxide. Even materials that are considered to be pure elements often contain a coating of oxides. For example, aluminum foil has a thin skin of Al₂O₃ that protects the foil from further corrosion.

OXIDIZED:

1. to convert (an element) into an oxide; combine with oxygen.
 2. to cover with a coating of oxide or rust.
 3. to take away hydrogen, as by the action of oxygen; add oxygen or any nonmetal.
 4. to remove electrons from (an atom or molecule), thereby increasing the valence. Compare REDUCE (def. 12).
- verb (used without object)
5. to become oxidized.

OXIDIZING: The process of breaking down organic wastes into simpler elemental forms or by products. Also used to separate combined chlorine and convert it into free chlorine.

OXYGEN DEFICIENT ENVIRONMENT: One of the most dangerous threats to an operator upon entering a manhole.

OZONE: Ozone or trioxygen (O₃) is a triatomic molecule, consisting of three oxygen atoms. It is an allotrope of oxygen that is much less stable than the diatomic O₂. Ground-level ozone is an air pollutant with harmful effects on the respiratory systems of animals. Ozone in the upper atmosphere filters potentially damaging ultraviolet light from reaching the Earth's surface. It is present in low concentrations throughout the Earth's atmosphere. It has many industrial and consumer applications. Ozone, the first allotrope of a chemical element to be recognized by science, was proposed as a distinct chemical compound by Christian Friedrich Schönbein in 1840, who named it after the Greek word for smell (ozein), from the peculiar odor in lightning storms. The formula for ozone, O₃, was not determined until 1865 by Jacques-Louis Soret and confirmed by Schönbein in 1867. Ozone is a powerful oxidizing agent, far better than dioxygen. It is also unstable at high concentrations, decaying to ordinary diatomic oxygen (in about half an hour in atmospheric conditions):
$$2 \text{O}_3 = 3 \text{O}_2$$

This reaction proceeds more rapidly with increasing temperature and decreasing pressure. Deflagration of ozone can be triggered by a spark, and can occur in ozone concentrations of 10 wt% or higher.

OZONE DOES NOT PROVIDE A RESIDUAL: One of the major drawbacks to using ozone as a disinfectant.

OZONE, CHLORINE DIOXIDE, UV, CHLORAMINES: These chemicals may be used as alternative disinfectants.

PAC: A disadvantage of using PAC is it is very abrasive and requires careful maintenance of equipment. One precaution that should be taken in storing PAC is that bags of carbon should not be stored near bags of HTH. Removes tastes and odors by adsorption only. Powdered activated carbon frequently used for taste and odor control because PAC is non-specific and removes a broad range of compounds. Jar tests and threshold odor number testing determines the application rate for powdered activated carbon. Powdered activated carbon, or PAC, commonly used for in a water treatment plant for taste and odor control. Powdered activated carbon may be used with some success in removing the precursors of THMs

PACKING: Material, usually of woven fiber, placed in rings around the shaft of a pump and used to control the leakage from the stuffing box.

PARAMECIUM: Paramecia are a group of unicellular ciliate protozoa formerly known as slipper animalcules from their slipper shape. They are commonly studied as a representative of the ciliate group. Simple cilia cover the body which allows the cell to move with a synchronous motion (like a caterpillar). There is also a deep oral groove containing inconspicuous compound oral cilia (as found in other peniculids) that is used to draw food inside. They generally feed upon bacteria and other small cells. Osmoregulation is carried out by a pair of contractile vacuoles, which actively expel water absorbed by osmosis from their surroundings. Paramecia are widespread in freshwater environments, and are especially common in scums. Paramecia are attracted by acidic conditions. Certain single-celled eukaryotes, such as Paramecium, are examples for exceptions to the universality of the genetic code (translation systems where a few codons differ from the standard ones).

PATHOGENS: Disease-causing pathogens; waterborne pathogens A pathogen may contaminate water and cause waterborne disease.

Pb: The chemical symbol of Lead.

PCE: Perchloroethylene. Known also as perc or tetrachloroethylene, perchloroethylene is a clear, colorless liquid with a distinctive, somewhat ether-like odor. It is non-flammable, having no measurable flashpoint or flammable limits in air. Effective over a wide range of applications, perchloroethylene is supported by closed loop transfer systems, stabilizers and employee exposure monitoring.

PEAK DEMAND: The maximum momentary load placed on a water treatment plant, pumping station or distribution system.

PERCOLATION: The process of fluid penetrating or slowly flowing through soil, rock, or formation. See also infiltration.

PERCUSSION RIG: See Cable Tool.

PERFORATED SCREEN: Well screen that has openings mechanically cut into it.

PERFORMANCE CURVE: A graphical representation of a pumps efficiency relative to gpm and feet of head.

PEPTIDOGLYCAN: A polymer found in the cell walls of prokaryotes that consists of polysaccharide and peptide chains in a strong molecular network. Also called *mucopeptide*, *murein*.

PERMEATE: The term for water which has passed through the membrane of a reverse osmosis unit.

PERMEABILITY: A measure of a soil or formation's capacity to transmit water, typically in volume per time units. Equivalent to Darcy's hydraulic conductivity.

PERMEABLE: Soil or formation of which water can pass through.

pH: A unit of measure which describes the degree of acidity or alkalinity of a solution. The pH scale runs from 0 to 14 with 7 being the mid-point or neutral. A pH of less than 7 is on the acid side of the scale with 0 as the point of greatest acid activity. A pH of more than 7 is on the basic (alkaline) side of the scale with 14 as the point of greatest basic activity. The term pH is derived from "p", the mathematical symbol of the negative logarithm, and "H", the chemical symbol of Hydrogen. The definition of pH is the negative logarithm of the Hydrogen ion activity. $pH = -\log[H^+]$.

pH OF SATURATION: The ideal pH for perfect water balance in relation to a particular total alkalinity level and a particular calcium hardness level, at a particular temperature. The pH where the Langelier Index equals zero.

PHENOLPHTHALEIN/TOTAL ALKALINITY: The relationship between the alkalinity constituent's bicarbonate, carbonate, and hydroxide can be based on the P and T alkalinity measurement.

PHENOL RED: Chemical reagent used for testing pH in the range of 6.8 - 8.4.

PHOSPHATE, NITRATE AND ORGANIC NITROGEN: Nutrients in a domestic water supply reservoir may cause water quality problems if they occur in moderate or large quantities.

PHYSISORPTION: (Or physical adsorption) Is adsorption in which the forces involved are intermolecular forces (van der Waals forces) of the same kind as those responsible for the imperfection of real gases and the condensation of vapors, and which do not involve a significant change in the electronic orbital patterns of the species involved. The term van der Waals adsorption is synonymous with physical adsorption, but its use is not recommended.

PICOCURIE: A unit of radioactivity. "Pico" is a metric prefix that means one one-millionth of one one-millionth. A picocurie is one one-millionth of one one-millionth of a Curie. A Curie is that quantity of any radioactive substance that undergoes 37 billion nuclear disintegrations per second. Thus a picocurie is that quantity of any radioactive substance that undergoes 0.037 nuclear disintegrations per second.

pCi/L: Picocuries per liter A curie is the amount of radiation released by a set amount of a certain compound. A picocurie is one quadrillionth of a curie.

PICOCURIE: A unit of radioactivity. "Pico" is a metric prefix that means one one-millionth of one one-millionth. A picocurie is one one-millionth of one one-millionth of a Curie. A Curie is that quantity of any radioactive substance that undergoes 37 billion nuclear disintegrations per second. Thus a picocurie is that quantity of any radioactive substance that undergoes 0.037 nuclear disintegrations per second.

PIEZOMETRIC SURFACE: See potentiometric surface.

PILOT BIT: A bit used on auger rigs to cut a pilot hole ahead of the cutter head when drilling into more resistant formations.

PIPELINE APPURTENANCE: Pressure reducers, bends, valves, regulators (which are a type of valve), etc.

PITLESS ADAPTER: A fitting installed on a section of column pipe and well casing permitting piping from the well to be installed below grade. (Often requires a special permit for construction)

PLANKTON: The aggregate of passively floating, drifting, or somewhat motile organisms occurring in a body of water, primarily comprising microscopic algae and protozoa.

PLATFORM: The portion of the drilling rig where a driller and crew operate the drill rig.

PLUG: A removable cap installed behind the pilot and cutter bits on hollow stem auger flighting.

POINT OF ENTRY: POE.

POLLUTION: To make something unclean or impure. See Contaminated.

POLYPHOSPHATES: Chemicals that may be added to remove low levels of iron and manganese.

POLYMER: A type of chemical when combined with other types of coagulants aid in binding small suspended particles to larger particles to help in the settling and filtering processes.

PORE SPACE: The interstitial space between sediments and fractures that is capable of storing and transmitting water.

POROSITY: A factor representing a rock, soil, or formations percentage of open space available for the percolation and storage of groundwater.

POST-CHLORINE: Where the water is chlorinated to make sure it holds a residual in the distribution system.

POTABLE: Good water which is safe for drinking or cooking purposes. Non-Potable: A liquid or water that is not approved for drinking.

POTENTIAL ENERGY: The energy that a body has by virtue of its position or state enabling it to do work.

POTENTIOMETRIC SURFACE: An imaginary surface representing the height a column of water will reach at any location within a confined aquifer. The measured surface of a confined aquifer related to the aquifer's pressure head.

PPM: Abbreviation for parts per million.

PRE-CHLORINE: Where the raw water is dosed with a large concentration of chlorine.

PRE-CHLORINATION: The addition of chlorine before the filtration process will help:

- > Control algae and slime growth
- > Control mud ball formation
- > Improve coagulation
- > Precipitate iron

The addition of chlorine to the water prior to any other plant treatment processes.

PERKINESIS: The aggregation resulting from random thermal motion of fluid molecules.

PRESSURE: Pressure is defined as force per unit area. It is usually more convenient to use pressure rather than force to describe the influences upon fluid behavior. The standard unit for pressure is the Pascal, which is a Newton per square meter. For an object sitting on a surface, the force pressing on the surface is the weight of the object, but in different orientations it might have a different area in contact with the surface and therefore exert a different pressure.

PRESSURE HEAD: The height of a column of water capable of being maintained by pressure. See also Total Head, Total Dynamic Head.

PRESSURE MEASUREMENT: Bourdon tube, Bellows gauge and Diaphragm are commonly used to measure pressure in waterworks systems. A Bellows-type sensor reacts to a change in pressure.

PREVENTION: To take action; stop something before it happens.

PROTON, NEUTRON AND ELECTRON: Are the 3 fundamental particles of an atom.

PRODUCING ZONE: A specific productive interval.

PRODUCTIVE INTERVAL: The portion or portions of an aquifer in which significant water production is obtained within the well.

PROTIST: Any of a group of eukaryotic organisms belonging to the kingdom Protista according to some widely used modern taxonomic systems. The protists include a variety of unicellular, coenocytic, colonial, and multicellular organisms, such as the protozoans, slime molds, brown algae, and red algae. A unicellular protist in taxonomic systems in which the protists are considered to form a kingdom.

PROTOCTIST: Any of various unicellular eukaryotic organisms and their multicellular, coenocytic, or colonial descendants that belong to the kingdom Protocista according to some taxonomic systems. The protocists include the protozoans, slime molds, various algae, and other groups. In many new classification systems, all protocists are considered to be protists.

PROTOZOA: Microscopic animals that occur as single cells. Some protozoa can cause disease in humans. Protozoa form cysts, which are specialized cells like eggs that are very resistant to chlorine. Cysts can survive the disinfection process, then "hatch" into normal cells that can cause disease. Protozoa must be removed from drinking water by filtration, because they cannot be effectively killed by chlorine.

PUBLIC NOTIFICATION: An advisory that EPA requires a water system to distribute to affected consumers when the system has violated MCLs or other regulations. The notice advises consumers what precautions, if any, they should take to protect their health.

PUBLIC WATER SYSTEM (PWS): Any water system which provides water to at least 25 people for at least 60 days annually. There are more than 170,000 PWSs providing water from wells, rivers and other sources to about 250 million Americans. The others drink water from private wells. There are differing standards for PWSs of different sizes and types.

PUMP SURGING: A process of well development whereby water is pumped nearly to the surface and then is allowed to fall back into the well. The process creates a backwashing action that cleans the well and nearby formation.

PUMPING LIFT: The height to which water must be pumped or lifted to, feet of head.

PWS: 3 types of public water systems. Community water system, non-transient non-community water system, transient non community water system.

RADIOCHEMICALS: (Or radioactive chemicals) Occur in natural waters. Naturally radioactive ores are particularly common in the Southwestern United States, and some streams and wells can have dangerously high levels of radioactivity. Total alpha and beta radioactivity and isotopes of radium and strontium are the major tests performed for radiochemicals. The federal drinking water standard for gross alpha radioactivity is set at 5 picocuries per liter.

RADIUS OF INFLUENCE: The distance away from a pumping well that water levels are affected by a wells cone of depression.

RAWHIDING: See Pump Surging.

RAW TURBIDITY: The turbidity of the water coming to the treatment plant from the raw water source.

RAW WATER: Water that has not been treated in any way; it is generally considered to be unsafe to drink.

REAGENT: A substance used in a chemical reaction to measure, detect, examine, or produce other substances.

REAM: The process of enlarging a borehole.

REAMER BIT: A special bit designed to ream existing boreholes.

RECHARGE: The infiltration component of the hydrologic cycle. Often used in the context of referring to: The infiltration of water back into an aquifer, resulting in the restoration of lost storage and water levels which had been decreased due to pumping and/or natural discharges from the aquifer.

RECIRCULATING SYSTEM: A system of constructed or surface mud pits that settle out cuttings from drilling fluid to be circulated back down the borehole.

RECORDER, FLOW: A flow recorder that measures flow is most likely to be located anywhere in the plant where a flow must be measured and in a central location.

RED WATER AND SLIME: Iron bacteria are undesirable in a water distribution system because of red water and slime complaints.

REDOX POTENTIAL: Reduction potential (also known as redox potential, oxidation / reduction potential or ORP) is the tendency of a chemical species to acquire electrons and thereby be reduced. Each species has its own intrinsic reduction potential; the more positive the potential, the greater the species' affinity for electrons and tendency to be reduced. In aqueous solutions, the reduction potential is the tendency of the solution to either gain or lose electrons when it is subject to change by introduction of a new species. A solution with a higher (more positive) reduction potential than the new species will have a tendency to gain electrons from the new species (i.e. to be reduced by oxidizing the new species) and a solution with a lower (more negative) reduction potential will have a tendency to lose electrons to the new species (i.e. to be oxidized by reducing the new species).

RELAY LOGIC: The name of a popular method of automatically controlling a pump, valve, chemical feeder, and other devices.

RESERVOIR: An impoundment used to store water.

RESIDUAL DISINFECTION PROTECTION: A required level of disinfectant that remains in treated water to ensure disinfection protection and prevent recontamination throughout the distribution system (i.e., pipes).

REVERSE MUD ROTARY: A non-conventional drilling method in which drilling fluid is injected through the borehole annulus downward through the bit and circulated back to the surface through the drill string.

REVERSE OSMOSIS: Forces water through membranes that contain holes so small that even salts cannot pass through. Reverse osmosis removes microorganisms, organic chemicals, and inorganic chemicals, producing very pure water. For some people, drinking highly purified water exclusively can upset the natural balance of salts in the body. Reverse osmosis units require regular maintenance or they can become a health hazard.

RIBBED STABILIZER: A stabilizer or drill collar that has cutting ribs attached to its side. Ribs are normally installed in vertical or spiral arrangements.

ROLLER BIT: A rotary drill bit having rotating cutting heads.

ROTAMETER: The name of transparent tube with a tapered bore containing a ball is often used to measure the rate of flow of a gas or liquid.

ROTARY RIG: A conventional rotary drill rig. Can be either an air or mud rotary rig.

ROTIFER: Rotifers get their name (derived from Greek and meaning "wheel-bearer"; they have also been called wheel animalcules) from the corona, which is composed of several ciliated tufts around the mouth that in motion resemble a wheel. These create a current that sweeps food into the mouth, where it is chewed up by a characteristic pharynx (called the mastax) containing a tiny, calcified, jaw-like structure called the trophi. The cilia also pull the animal, when unattached, through the water. Most free-living forms have pairs of posterior toes to anchor themselves while feeding. Rotifers have bilateral symmetry and a variety of different shapes. There is a well-developed cuticle which may be thick and rigid, giving the animal a box-like shape, or flexible, giving the animal a worm-like shape; such rotifers are respectively called loricate and illoricate.

RUNOFF: Surface water sources such as a river or lake are primarily the result of natural processes of runoff.

SAFE YIELD: A possible consequence when the "safe yield" of a well is exceeded and water continues to be pumped from a well, is land subsidence around the well will occur. Safe yield refers to a long-term balance between the water that is naturally and artificially recharged to an aquifer and the groundwater that is pumped out. When more water is removed than is recharged, the aquifer is described as being out of safe yield. When the water level in the aquifer then drops, we are said to be mining groundwater.

SALTS ARE ABSENT: Is a strange characteristic that is unique to water vapor in the atmosphere.

SAMPLE: The water that is analyzed for the presence of EPA-regulated drinking water contaminants. Depending on the regulation, EPA requires water systems and states to take samples from source water, from water leaving the treatment facility, or from the taps of selected consumers.

SAMPLING LOCATION: A location where soil or cuttings samples may be readily and accurately collected.

SAND, ANTHRACITE AND GARNET: Mixed media filters are composed of these three materials.

SANITARY SURVEY: Persons trained in public health engineering and the epidemiology of waterborne diseases should conduct the sanitary survey. The importance of a detailed sanitary survey of a new water source cannot be overemphasized. An on-site review of the water sources, facilities, equipment, operation, and maintenance of a public water systems for the purpose of evaluating the adequacy of the facilities for producing and distributing safe drinking water. The purpose of a non-regulatory sanitary survey is to identify possible biological and chemical pollutants which might affect a water supply.

SANITIZER: A disinfectant or chemical which disinfects (kills bacteria), kills algae and oxidizes organic matter.

SATURATION INDEX: See Langelier's Index.

SATURATOR: A device which produces a fluoride solution for the fluoride process. Crystal-grade types of sodium fluoride should be fed with a saturator. Overfeeding must be prevented to protect public health when using a fluoridation system.

SATURATED ZONE: Where an unconfined aquifer becomes saturated beneath the capillary fringe.

SCADA: A remote method of monitoring pumps and equipment. 130 degrees F is the maximum temperature that transmitting equipment is able to with stand. If the level controller may be set with too close a tolerance 45 could be the cause of a control system that is frequently turning a pump on and off.

SCALE: Crust of calcium carbonate, the result of unbalanced water. Hard insoluble minerals deposited (usually calcium bicarbonate) which forms on pool and spa surfaces and clog filters, heaters and pumps. Scale is caused by high calcium hardness and/or high pH. The regular use of stain prevention chemicals can prevent scale.

SCHMUTZDECKE: German, "grime or filth cover", sometimes spelt schmutzedecke) is a complex biological layer formed on the surface of a slow sand filter. The schmutzdecke is the layer that provides the effective purification in potable water treatment, the underlying sand providing the support medium for this biological treatment layer. The composition of any particular schmutzdecke varies, but will typically consist of a gelatinous biofilm matrix of bacteria, fungi, protozoa, rotifera and a range of aquatic insect larvae. As a schmutzdecke ages, more algae tend to develop, and larger aquatic organisms may be present including some bryozoa, snails and annelid worms.

SCROLL AND BASKET: The two basic types of centrifuges used in water treatment.

SEAL: For wells: to abandon a well by filling up the well with approved seal material including cementing with grout from a required depth to the land surface.

SECONDARY DRINKING WATER STANDARDS: Non-enforceable federal guidelines regarding cosmetic effects (such as tooth or skin discoloration) or aesthetic effects (such as taste, odor, or color) of drinking water.

SECTIONAL MAP: The name of a map that provides detailed drawings of the distribution system's zones. Sometimes we call these quarter-sections.

SEDIMENTATION BASIN: Where the thickest and greatest concentration of sludge will be found. Twice a year sedimentation tanks should be drained and cleaned if the sludge buildup interferes with the treatment process.

SEDIMENTATION: The process of suspended solid particles settling out (going to the bottom of the vessel) in water.

SEDIMENT: Grains of soil, sand, gravel, or rock deposited by and generated by water movement.

SENSOR: A float and cable system are commonly found instruments that may be used as a sensor to control the level of liquid in a tank or basin.

SESSILE: *Botany.* attached by the base, or without any distinct projecting support, as a leaf issuing directly from the stem. *Zoology.* permanently attached; not freely moving.

SETTLED SOLIDS: Solids that have been removed from the raw water by the coagulation and settling processes.

SHAKER: A device used in mud containment systems that vibrates various sized screens as drilling fluid passes through it, thereby separating cuttings from drilling fluid and providing a good sampling location.

SHOCK: Also known as superchlorination or break point chlorination. Ridding a water of organic waste through oxidization by the addition of significant quantities of a halogen.

SHORT-CIRCUITING: Short Circuiting is a condition that occurs in tanks or basins when some of the water travels faster than the rest of the flowing water. This is usually undesirable since it may result in shorter contact, reaction or settling times in comparison with the presumed detention times.

SHROUD: A baffle or piece of pipe installed over a pump to force water to pass the pumps motor.

SIEVE ANALYSIS: The process of sifting soil or formation samples through a series of screens to determine percentages of particle sizes.

SINGLE PHASE POWER: The type of power used for lighting systems, small motors, appliances, portable power tools and in homes.

SINUSOID: A curve described by the equation $y = a \sin x$, the ordinate being proportional to the sine of the abscissa.

SINUSOIDAL: Mathematics. Of or pertaining to a sinusoid. Having a magnitude that varies as the sine of an independent variable: a sinusoidal current.

SLUDGE BASINS: After cleaning sludge basins and before returning the tanks into service the tanks should be inspected, repaired if necessary, and disinfected.

SLUDGE REDUCTION: Organic polymers are used to reduce the quantity of sludge. If a plant produces a large volume of sludge, the sludge could be dewatered, thickened, or conditioned to decrease the volume of sludge. Turbidity of source water, dosage, and type of coagulant used are the most important factors which determine the amount of sludge produced in a treatment of water.

SLURRY: A mixture of crushed rock and water.

SMALL WATER SYSTEM: 3,300 or fewer persons.

SOC: Synthetic organic chemical. A common way for a synthetic organic chemical such as dioxin to be introduced to a surface water supply is from an industrial discharge, agricultural drainage, or a spill.

SODA ASH: Chemical used to raise pH and total alkalinity (sodium carbonate)

SODIUM BICARBONATE: Commonly used to increase alkalinity of water and stabilize pH.

SODIUM BISULFATE: Chemical used to lower pH and total alkalinity (dry acid).

SODIUM HYDROXIDE: Also known as caustic soda, a by-product chlorine generation and often used to raise pH.

SOIL MOISTURE: A relative consideration of the degree to which a soil is saturated.

SOFTENING WATER: When the water has a low alkalinity it is advantageous to use soda ash instead of caustic soda for softening water.

SOFTENING: The process that removes the ions which cause hardness in water.

SOLAR DRYING BEDS OR LAGOONS: Are shallow, small-volume storage pond where sludge is concentrated and stored for an extended periods.

SOLAR DRYING BEDS, CENTRIFUGES AND FILTER PRESSES: Are procedures used in the dewatering of sludge.

SOLID, LIQUID AND VAPOR: 3 forms of matter.

SOLDER: A fusible alloy used to join metallic parts.

SOLID STEM (AUGER): An auger that is constructed of solid stem drill flights.

SPADNS: The lab reagent called SPADNS solution is used in performing the Fluoride test.

SPECIFIC CAPACITY (Sc): A measure of a well's pumping performance in gallons per minute per foot of drawdown.

SPIDER: A bearing or flange used in vertical turbine pumps to stabilize the drive shaft or shaft tube and seal column joints.

SPIRAL FLANGE: A continuous blade that wraps spirally around auger flighting.

SPIRIT OF HARTSHORN: A colorless, pungent, suffocating, aqueous solution of about 28.5 percent ammonia gas: used chiefly as a detergent, for removing stains and extracting certain vegetable coloring agents, and in the manufacture of ammonium salts.

SPLIT SPOON: A sampling device that is driven into the earth and operated by a wire line for the retrieval of soil or formation samples.

SPLIT FLOW CONTROL SYSTEM: This type of control system is to control the flow to each filter influent which is divided by a weir.

SPRAY BOTTLE OF AMMONIA: An operator should use ammonia to test for a chlorine leak around a valve or pipe. You will see white smoke if there is a leak.

SPRING PRESSURE: Is what maintains contact between the two surfaces of a mechanical seal.

STABLE: Reference to formation, soil, or sediments of sufficient strength to remain in place under its own weight and existing pressures.

STABILIZE: Actions taken to enhance borehole stability or vertical rotational when drilling.

STABILIZER: The portion of a drill string used to stabilize rotation.

STANDPIPE: A water tank that is taller than it is wide. Should not be found in low point.

STERILIZED GLASSWARE: The only type of glassware that should be used in testing for coliform bacteria.

STORAGE TANKS: Three types of water usage that determine the volume of a storage tank are fire suppression storage, equalization storage, and emergency storage. Equalization storage is the volume of water needed to supply the system for periods when demand exceeds supply. Generally, a water storage tank's interior coating (paint) protects the interior about 3-5 years.

S.T.P.: Standard temperature and pressure standard temperature and pressure the temperature of 0°C and pressure of 1 atmosphere, usually taken as the conditions when stating properties of gases.

STRATIFIED: Layered.

STUFFING BOX: That portion of the pump that houses the packing or mechanical seal.

SUB: A small section of drill pipe used to connect larger sections.

SUBMERSIBLE PUMP: A turbine pump that has the motor attached directly to it and therefore is operated while submerged.

SULFATE: Will readily dissolve in water to form an anion. Sulfate is a substance that occurs naturally in drinking water. Health concerns regarding sulfate in drinking water have been raised because of reports that diarrhea may be associated with the ingestion of water containing high levels of sulfate. Of particular concern are groups within the general population that may be at greater risk from the laxative effects of sulfate when they experience an abrupt change from drinking water with low sulfate concentrations to drinking water with high sulfate concentrations.

Sulfate in drinking water currently has a secondary maximum contaminant level (SMCL) of 250 milligrams per liter (mg/L), based on aesthetic effects (i.e., taste and odor). This regulation is not a federally enforceable standard, but is provided as a guideline for States and public water systems. EPA estimates that about 3% of the public drinking water systems in the country may have sulfate levels of 250 mg/L or greater. The Safe Drinking Water Act (SDWA), as amended in 1996, directs the U.S. Environmental Protection Agency (EPA) and the Centers for Disease Control and Prevention (CDC) to jointly conduct a study to establish a reliable dose-response relationship for the adverse human health effects from exposure to sulfate in drinking water, including the health effects that may be experienced by sensitive subpopulations (infants and travelers). SDWA specifies that the study be based on the best available peer-reviewed science and supporting studies, conducted in consultation with interested States, and completed in February 1999.

SULFIDE: The term sulfide refers to several types of chemical compounds containing sulfur in its lowest oxidation number of -2. Formally, "sulfide" is the dianion, S_2^{2-} , which exists in strongly alkaline aqueous solutions formed from H_2S or alkali metal salts such as Li_2S , Na_2S , and K_2S . Sulfide is exceptionally basic and, with a $pK_a > 14$, it does not exist in appreciable concentrations even in highly alkaline water, being undetectable at $pH < \sim 15$ (8 M NaOH). Instead, sulfide combines with electrons in hydrogen to form HS^- , which is variously called hydrogen sulfide ion, hydrosulfide ion, sulfhydryl ion, or bisulfide ion. At still lower pH's (<7), HS^- converts to H_2S , hydrogen sulfide. Thus, the exact sulfur species obtained upon dissolving sulfide salts depends on the pH of the final solution. Aqueous solutions of transition metals cations react with sulfide sources (H_2S , $NaSH$, Na_2S) to precipitate solid sulfides. Such inorganic sulfides typically have very low solubility in water and many are related to minerals. One famous example is the bright yellow species CdS or "cadmium yellow". The black tarnish formed on sterling silver is Ag_2S . Such species are sometimes referred to as salts. In fact, the bonding in transition metal sulfides is highly covalent, which gives rise to their semiconductor properties, which in turn is related to the practical applications of many sulfide materials.

SUPERNATANT: The liquid layer which forms above the sludge in a settling basin.

SURFACE SEAL: The upper portion of a wells construction where surface contaminants are adequately prevented from entering the well, normally consisting of surface casing and neat cement grout.

SURFACE WATER SOURCES: Surface water sources such as a river or lake are primarily the result of Runoff.

SURFACE WATER: Water that is open to the atmosphere and subject to surface runoff; generally, lakes, streams, rivers.

SURFACTANT: Surfactants reduce the surface tension of water by adsorbing at the liquid-gas interface. They also reduce the interfacial tension between oil and water by adsorbing at the liquid-liquid interface. Many surfactants can also assemble in the bulk solution into aggregates. Examples of such aggregates are vesicles and micelles. The concentration at which surfactants begin to form micelles is known as the critical micelle concentration or CMC. When micelles form in water, their tails form a core that can encapsulate an oil droplet, and their (ionic/polar) heads form an outer shell that maintains favorable contact with water. When surfactants assemble in oil, the aggregate is referred to as a reverse micelle. In a reverse micelle, the heads are in the core and the tails maintain favorable contact with oil. Surfactants are also often classified into four primary groups; anionic, cationic, non-ionic, and zwitterionic (dual charge).

SUSCEPTIBILITY WAIVER: A waiver that is granted based upon the results of a vulnerability assessment.

SURGE-BLOCK: A disc shaped device that fits tightly into a well and is moved up and down to agitate the water column in order to develop a well.

SURGING: The process of purging a well rapidly for well development.

SWAB: See Surge-block.

SWING ARM: A large moveable arm on a bucket auger rig that pulls the bucket auger out away from the drilling rig for dumping.

SYNCHRONY: Simultaneous occurrence; synchronism.

TABLE DRIVE: A drilling rig that uses a rotating table within the platform to turn a kelly driven drill string.

TABLE: The back portion of a drill rig where the drill pipe is inserted (or driven if a table drive), adjacent to or within the driller's platform.

TAPPING VALVE: The name of the valve that is specifically designed for connecting a new water main to an existing main that is under pressure.

TARGET DEPTH: The proposed construction depth of a well prior to drilling.

TASTE AND ODORS: The primary purpose to use potassium permanganate in water treatment is to control taste and odors. Anaerobic water undesirable for drinking water purposes because of color and odor problems are more likely to occur under these conditions. Taste and odor problems in the water may happen if sludge and other debris are allowed to accumulate in a water treatment plant.

TCE, trichloroethylene: A solvent and degreaser used for many purposes; for example dry cleaning, it is a common groundwater contaminant. Trichloroethylene is a colorless liquid which is used as a solvent for cleaning metal parts. Drinking or breathing high levels of trichloroethylene may cause nervous system effects, liver and lung damage, abnormal heartbeat, coma, and possibly death. Trichloroethylene has been found in at least 852 of the 1,430 National Priorities List sites identified by the Environmental Protection Agency (EPA).

TDS-TOTAL DISSOLVED SOLIDS: An expression for the combined content of all inorganic and organic substances contained in a liquid which are present in a molecular, ionized or micro-granular (colloidal sol) suspended form. Generally, the operational definition is that the solids (often abbreviated TDS) must be small enough to survive filtration through a sieve size of two micrometers. Total dissolved solids are normally only discussed for freshwater systems, since salinity comprises some of the ions constituting the definition of TDS. The principal application of TDS is in the study of water quality for streams, rivers and lakes, although TDS is generally considered not as a primary pollutant (e.g. it is not deemed to be associated with health effects), but it is rather used as an indication of aesthetic characteristics of drinking water and as an aggregate indicator of presence of a broad array of chemical contaminants. Ion exchange is an effective treatment process used to remove iron and manganese in a water supply. This process is ideal as long as the water does not contain a large amount of TDS. When determining the total dissolved solids, a sample should be filtered before being poured into an

evaporating dish and dried. Demineralization may be necessary in a treatment process if the water has a very high value Total Dissolved Solids.

TELEMETERING: The use of a transmission line with remote signaling to monitor a pumping station or motors. Can be used to accomplish accurate and reliable remote monitoring and control over a long distribution system.

TEMPERATURE SAMPLE: This test should be performed immediately in the field, this is a grab sample.

TELESCOPING KELLY: A kelly with successively smaller sized pipe within itself that drops out as a borehole is drilled. This permits that drilling may proceed without adding drill pipe. Normally found on bucket auger rigs.

TELESCOPING: The successive decrease in borehole size with depth.

THE RATE DECREASES: In general, when the temperature decreases, the chemical reaction rate decreases also.

THICKENING, CONDITIONING AND DEWATERING: Common processes that are utilized to reduce the volume of sludge.

TIME FOR TURBIDITY BREAKTHROUGH AND MAXIMUM HEADLOSS: Are the two factors which determine whether or not a change in filter media size should be made.

TITRATION: A method of testing by adding a reagent of known strength to a water sample until a specific color change indicates the completion of the reaction.

TITRIMETRIC: Chemistry. Using or obtained by titration. Titrimetrically, adverb.

TOP DRIVE: A rotary type drill head that moves freely up and down the rigs mast while driving the drill string.

TOROID: A surface generated by the revolution of any closed plane curve or contour about an axis lying in its plane. The solid enclosed by such a surface.

TOTAL ALKALINITY: A measure of the acid-neutralizing capacity of water which indicates its buffering ability, i.e. measure of its resistance to a change in pH. Generally, the higher the total alkalinity, the greater the resistance to pH change.

TOTAL COLIFORM: Total coliform, fecal coliform, and E. coli are all indicators of drinking water quality. The total coliform group is a large collection of different kinds of bacteria. Fecal coliforms are types of total coliform that mostly exist in feces. E. coli is a sub-group of fecal coliform. When a water sample is sent to a lab, it is tested for total coliform. If total coliform is present, the sample will also be tested for either fecal coliform or E. coli, depending on the lab testing method.

TOTAL DISSOLVED SOLIDS (TDS): The accumulated total of all solids that might be dissolved in water.

TOTAL DYNAMIC HEAD: The pressure (psi) or equivalent feet of water, required for a pump to lift water to its point of storage overcoming elevation head, friction loss, line pressure, drawdown and pumping lift.

TRANSIENT, NON-COMMUNITY WATER SYSTEM: TNCWS A water system which provides water in a place such as a gas station or campground where people do not remain for long periods of time. These systems do not have to test or treat their water for contaminants which pose long-term health risks because fewer than 25 people drink the water over a long period. They still must test their water for microbes and several chemicals. A Transient Non-community Water System: Is not required to sample for VOC's.

TREATED WATER: Disinfected and/or filtered water served to water system customers. It must meet or surpass all drinking water standards to be considered safe to drink.

TRIHALOMETHANES (THM): Four separate compounds including chloroform, dichlorobromomethane, dibromochloromethane, and bromoform. The most common class of disinfection by-products created when chemical disinfectants react with organic matter in water during the disinfection process. See Disinfectant Byproducts.

TRICONE BIT: A roller bit with three independent rolling bits with teeth or buttons that intermesh for efficient rock crushing and cutting.

TUBE SETTLERS: This modification of the conventional process contains many metal tubes that are placed in the sedimentation basin, or clarifier. These tubes are approximately 1 inch deep and 36 inches long, split-hexagonal shape and installed at an angle of 60 degrees or less. These tubes provide for a very large surface area upon which particles may settle as the water flows upward. The slope of the tubes facilitates gravity settling of the solids to the bottom of the basin, where they can be collected and removed. The large surface settling area also means that adequate clarification can be obtained with detention times of 15 minutes or less. As with conventional treatment, this sedimentation step is followed by filtration through mixed media.

TUBERCLES: The creation of this condition is of the most concern regarding corrosive water effects on a water system. Tubercles are formed due to joining dissimilar metals, causing electro-chemical reactions. Like iron to copper pipe. We have all seen these little rust mounds inside cast iron pipe.

TURBIDIMETER: Monitoring the filter effluent turbidity on a continuous basis with an in-line instrument is a recommended practice. Turbidimeter is best suited to perform this measurement.

TURBIDITY: A measure of the cloudiness of water caused by suspended particles.

TURBINE PUMP: A pump that utilizes rotating impellers on a shaft that generate centrifugal force for pumping water.

UNCONFINED AQUIFER: An aquifer that exists under atmospheric pressure and is not confined.

UNCONSOLIDATED: Sediment that is not cemented or is loosely arranged.

UNDER-REAM: The process of reaming, from within the borehole, a section of an existing smaller borehole area.

UNSATURATED ZONE: That portion of the subsurface, including the capillary fringe that is not saturated but may contain water in both vapor and liquid form. See also Vadose Zone.

UNSTABLE: Sediment or other material that cannot exist without rapidly decomposing or collapsing in on itself. (ex. unconsolidated sediment)

U.S. ENVIRONMENTAL PROTECTION AGENCY: In the United States, this agency responsible for setting drinking water standards and for ensuring their enforcement. This agency sets federal regulations which all state and local agencies must enforce.

UNDER PRESSURE IN STEEL CONTAINERS: After chlorine gas is manufactured, it is primarily transported in steel containers.

UNIT FILTER RUN VOLUME (UFRV): One of the most popular ways to compare filter runs. This technique is the best way to compare water treatment filter runs.

VADOSE ZONE: A portion of the subsurface above the water table that is not saturated but contains water in both vapor and liquid form. The portion of the subsurface where water percolates through to the saturated zone. See also Unsaturated Zone.

VANE: That portion of an impeller that throws the water toward the volute.

VARIABLE DISPLACEMENT PUMP: A pump that will produce different volumes of water dependent on the pressure head against it.

VELOCITY HEAD: The vertical distance a liquid must fall to acquire the velocity with which it flows through the piping system. For a given quantity of flow, the velocity head will vary indirectly as the pipe diameter varies.

VENTURI: If water flows through a pipeline at a high velocity, the pressure in the pipeline is reduced. Velocities can be increased to a point that a partial vacuum is created.

VERTICAL TURBINE: A type of variable displacement pump in which the motor or drive head is mounted on the wellhead and rotates a drive shaft connected to the pump impellers.

VIRION: A complete viral particle, consisting of RNA or DNA surrounded by a protein shell and constituting the infective form of a virus.

VIRUSES: Very small disease-causing microorganisms that are too small to be seen even with microscopes. Viruses cannot multiply or produce disease outside of a living cell.

VITRIFICATION: Vitrification is a process of converting a material into a glass-like amorphous solid that is free from any crystalline structure, either by the quick removal or addition of heat, or by mixing with an additive. Solidification of a vitreous solid occurs at the glass transition temperature (which is lower than melting temperature, T_m , due to supercooling). When the starting material is solid, vitrification usually involves heating the substances to very high temperatures. Many ceramics are produced in such a manner. Vitrification may also occur naturally when lightning strikes sand, where the extreme and immediate heat can create hollow, branching rootlike structures of glass, called fulgurite. When applied to whiteware ceramics, vitreous means the material has an extremely low permeability to liquids, often but not always water, when determined by a specified test regime. The microstructure of whiteware ceramics frequently contain both amorphous and crystalline phases.

VOC WAIVER: The longest term VOC waiver that a public water system using groundwater could receive is 9 years.

VOLATILE ORGANIC COMPOUNDS: (VOCs) Solvents used as degreasers or cleaning agents. Improper disposal of VOCs can lead to contamination of natural waters. VOCs tend to evaporate very easily. This characteristic gives VOCs very distinct chemical odors like gasoline, kerosene, lighter fluid, or dry cleaning fluid. Some VOCs are suspected cancer-causing agents. Volatile organic compounds (VOCs) are organic chemical compounds that have high enough vapor pressures under normal conditions to significantly vaporize and enter the atmosphere. A wide range of carbon-based molecules, such as aldehydes, ketones, and other light hydrocarbons are VOCs. The term often is used in a legal or regulatory context and in such cases the precise definition is a matter of law. These definitions can be contradictory and may contain "loopholes"; e.g. exceptions, exemptions, and exclusions. The United States Environmental Protection Agency defines a VOC as any organic compound that participates in a photoreaction; others believe this definition is very broad and vague as organics that are not volatile in the sense that they vaporize under normal conditions can be considered volatile by this EPA definition. The term may refer both to well characterized organic compounds and to mixtures of variable composition.

VOID: An opening, gap, or space within rock or sedimentary formations formed at the time of origin or deposition.

VOLTAGE: Voltage (sometimes also called electric or electrical tension) is the difference of electrical potential between two points of an electrical or electronic circuit, expressed in volts. It measures the potential energy of an electric field to cause an electric current in an electrical conductor. Depending on the difference of electrical potential it is called extra low voltage, low voltage, high voltage or extra high voltage. Specifically Voltage is equal to energy per unit charge.

VOLUTE: The spiral-shaped casing surrounding a pump impeller that collects the liquid discharge by the impeller.

VORTEX: The helical swirling of water moving towards a pump.

VIRUSES: Are very small disease-causing microorganisms that are too small to be seen even with microscopes. Viruses cannot multiply or produce disease outside of a living cell.

VOLATILE ORGANIC COMPOUNDS: (VOCs) Solvents used as degreasers or cleaning agents. Improper disposal of VOCs can lead to contamination of natural waters. VOCs tend to evaporate very easily. This characteristic gives VOCs very distinct chemical odors like gasoline, kerosene, lighter fluid, or dry cleaning fluid. Some VOCs are suspected cancer-causing agents.

VULNERABILITY ASSESSMENT: An evaluation of drinking water source quality and its vulnerability to contamination by pathogens and toxic chemicals.

WAIVERS: Monitoring waivers for nitrate and nitrite are prohibited.

WASHOUT: The rapid erosion of aquifer material from the borehole walls while a well is being drilled, which often results in a loss of circulation.

WATER COURSE: An opening within a cable tool drill string that allows fluid to flow in and out of the drill string thereby minimizing friction loss to the slurry.

WATER HAMMER: A surge in a pipeline resulting from the rapid increase or decrease in water flow. Water hammer exerts tremendous force on a system and can be highly destructive.

WATER PURVEYOR: The individuals or organization responsible to help provide, supply, and furnish quality water to a community.

WATER QUALITY: The 4 broad categories of water quality are: Physical, chemical, biological, radiological. Pathogens are disease causing organisms such as bacteria and viruses. A positive bacteriological sample indicates the presence of bacteriological contamination. Source water monitoring for lead and copper be performed when a public water system exceeds an action level for lead of copper.

WATER QUALITY CRITERIA: Comprised of both numeric and narrative criteria. Numeric criteria are scientifically derived ambient concentrations developed by EPA or States for various pollutants of concern to protect human health and aquatic life. Narrative criteria are statements that describe the desired water quality goal.

WATER QUALITY STANDARD: A statute or regulation that consists of the beneficial designated use or uses of a waterbody, the numeric and narrative water quality criteria that are necessary to protect the use or uses of that particular waterbody, and an antidegradation statement.

WATER TABLE: The measured water level surface of an unconfined aquifer.

WATER VAPOR: A characteristic that is unique to water vapor in the atmosphere is that water does not contain any salts.

WATERBORNE DISEASE: A disease, caused by a virus, bacterium, protozoan, or other microorganism, capable of being transmitted by water (e.g., typhoid fever, cholera, amoebic dysentery, gastroenteritis).

WATERSHED: An area that drains all of its water to a particular water course or body of water. The land area from which water drains into a stream, river, or reservoir.

WEATHERED: The existence of rock or formation in a chemically or physically broken down or decomposed state. Weathered material is in an unstable state.

WELL ABANDONMENT: The process of sealing a well by approved means. The filling of a well to the surface with cement grout.

WELL HEAD: The upper portion of the well that is constructed on the land surface, including the well manifold. Also a term used to refer to the area near the well that is subject to wellhead protection.

WELL HEAD PROTECTION: Programs designed to maintain the quality of groundwater used as public drinking water sources, by managing the land uses around the well field. A government program that encourages the limitation and elimination of activities, near and within a wells recharge area, which present a potential risk to the wells water supply.

WELL MANIFOLD: The piping, valves, and metering equipment used to connect the well to the distribution system, installed on the wellhead.

WELL SCREEN: A section of well casing that contains openings which permit water to enter the well but limit or prevent sediment from entering the well while pumping.

WELL SEAL: The watertight cap or seal installed within and between the well casing and pumping equipment. The metal or plastic plug or seal, which the pumping column rests on the top of casing.

WHOLE EFFLUENT TOXICITY: The total toxic effect of an effluent measured directly with a toxicity test.

YIELD: The volume of water measured in flow rates that are produced from the well.

ZONE OF AERATION: See Saturated Zone or Vadose Zone.

ZONE OF SATURATION: See Saturated Zone.



Top- Pre-sedimentation basin

Common Water Treatment and Distribution Chemicals

Chemical Name	Common Name	Chemical Formula
Aluminum hydroxide		Al(OH) ₃
Aluminum sulfate	Alum, liquid	Al ₂ (SO ₄) ₃ · 14(H ₂ O)
Ammonia		NH ₃
Ammonium		NH ₄
Bentonitic clay	Bentonite	
Calcium bicarbonate		Ca(HCO ₃) ₂
Calcium carbonate	Limestone	CaCO ₃
Calcium chloride		CaCl ₂
Calcium Hypochlorite	HTH	Ca(OCl) ₂ · 4H ₂ O
Calcium hydroxide	Slaked Lime	Ca(OH) ₂
Calcium oxide	Unslaked (Quicklime)	CaO
Calcium sulfate	Gypsum	CaSO ₄
Carbon	Activated Carbon	C
Carbon dioxide		CO ₂
Carbonic acid		H ₂ CO ₃
Chlorine gas		Cl ₂
Chlorine Dioxide		ClO ₂
Copper sulfate	Blue vitriol	CuSO ₄ · 5H ₂ O
Dichloramine		NHCl ₂
Ferric chloride	Iron chloride	FeCl ₃
Ferric hydroxide		Fe(OH) ₃
Ferric sulfate	Iron sulfate	Fe ₂ (SO ₄) ₃
Ferrous bicarbonate		Fe(HCO ₃) ₂
Ferrous hydroxide		Fe(OH) ₂
Ferrous sulfate	Copperas	FeSO ₄ · 7H ₂ O
Hydrofluorosilicic acid		H ₂ SiF ₆
Hydrochloric acid	Muriatic acid	HCl
Hydrogen sulfide		H ₂ S
Hypochlorous acid		HOCl
Magnesium bicarbonate		Mg(HCO ₃) ₂
Magnesium carbonate		MgCO ₃
Magnesium chloride		MgCl ₂
Magnesium hydroxide		Mg(OH) ₂
Magnesium dioxide		MgO ₂
Manganous bicarbonate		Mn(HCO ₃) ₂
Manganous sulfate		MnSO ₄
Monochloramine		NH ₂ Cl
Potassium bicarbonate		KHCO ₃
Potassium permanganate		KMnO ₄

Chemical Name	Common Name	Chemical Formula
Sodium carbonate	Soda ash	Na_2CO_3
Sodium chloride	Salt	NaCl
Sodium chlorite		NaClO_2
Sodium fluoride		NaF
Sodium fluorsilicate		Na_2SiF_6
Sodium hydroxide	Lye	NaOH
Sodium hypochlorite		NaOCl
Sodium Metaphosphate	Hexametaphosphate	NaPO_3
Sodium phosphate	Disodium phosphate	Na_3PO_4
Sodium sulfate		Na_2SO_4
Sulfuric acid		H_2SO_4



Fluoride. Many communities add fluoride to their drinking water to promote dental health. Each community makes its own decision about whether or not to add fluoride. The EPA has set an enforceable drinking water standard for fluoride of 4 mg/L (some people who drink water containing fluoride in excess of this level over many years could develop bone disease, including pain and tenderness of the bones). The EPA has also set a secondary fluoride standard of 2 mg/L to protect against dental fluorosis.

Microorganism Appendix



**COCCI
(SPHERICAL)**



**SPIRILLI
(SPIRAL)**



**BACILLI
(ROD-SHAPED)**

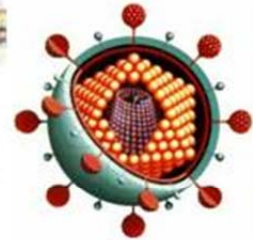
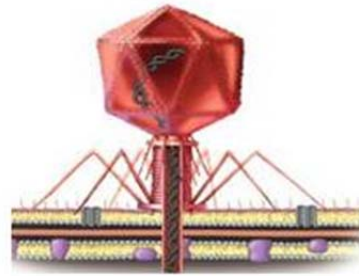

VIRUSES

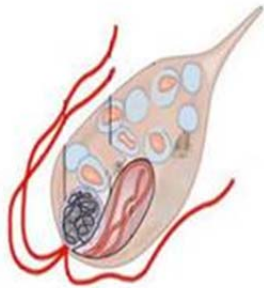

PROTOZOA

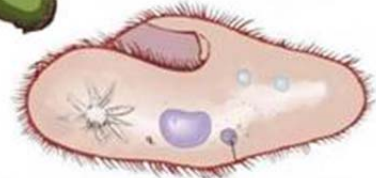
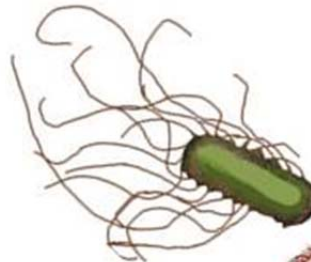

BACTERIA

BACTERIA TYPES



This section will give a close-up and short explanation of the major microorganisms found in water and in wastewater.

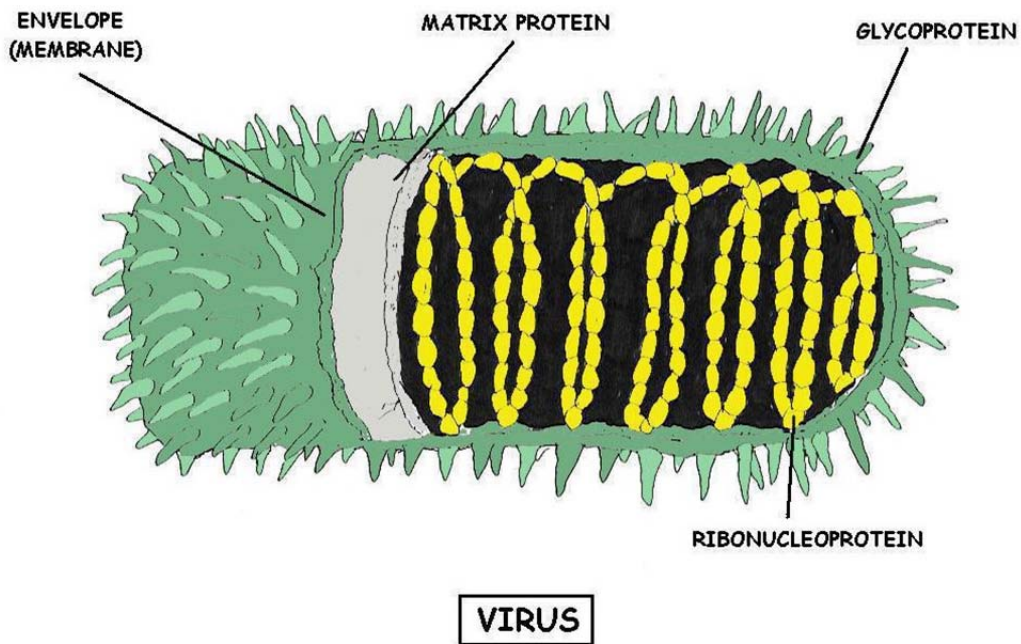

Protozoa

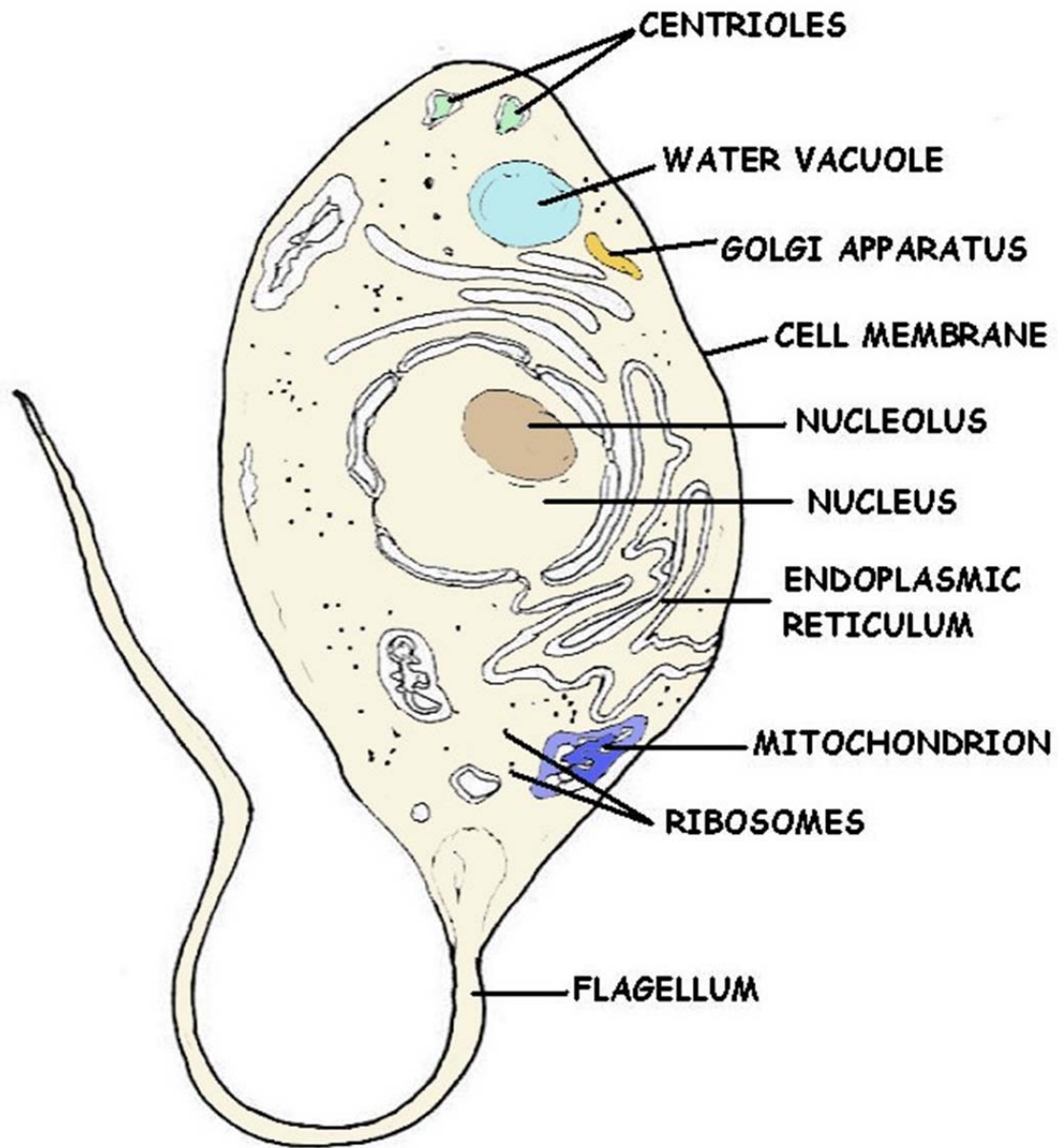

PROTOZOAN CELL

Protozoa are around 10–50 micrometer, but can grow up to 1 mm and can easily be seen under a microscope. Protozoa exist throughout aqueous environments and soil. Protozoa occupy a range of trophic levels. As predators, they prey upon unicellular or filamentous algae, bacteria, and microfungi.

Protozoa play a role both as herbivores and as consumers in the decomposer link of the food chain. Protozoa also play a vital role in controlling bacteria populations and biomass. As components of the micro- and meiofauna, protozoa are an important food source for microinvertebrates. Thus, the ecological role of protozoa in the transfer of bacterial and algal production to successive trophic levels is important. Protozoa such as the malaria parasites (*Plasmodium* spp.), trypanosomes and leishmania are also important as parasites and symbionts of multicellular animals.

Most protozoa exist in 5 stages of life which are in the form of trophozoites and cysts. As cysts, protozoa can survive harsh conditions, such as exposure to extreme temperatures and harmful chemicals, or long periods without access to nutrients, water, or oxygen for a period of time. Being a cyst enables parasitic species to survive outside of the host, and allows their transmission from one host to another. When protozoa are in the form of trophozoites (Greek, tropho=to nourish), they actively feed and grow. The process by which the protozoa takes its cyst form is called encystation, while the process of transforming back into trophozoite is called excystation.

Protozoa can reproduce by binary fission or multiple fission. Some protozoa reproduce sexually, some asexually, and some both (e.g. *Coccidia*). An individual protozoan is hermaphroditic.

Classification

Protozoa were commonly grouped in the kingdom of Protista together with the plant-like algae and fungus-like water molds and slime molds. In the 21st-century systematics, protozoans, along with ciliates, mastigophorans, and apicomplexans, are arranged as animal-like protists. However, protozoans are neither Animalia nor Metazoa (with the possible exception of the enigmatic, moldy Myxozoa).

Sub-groups

Protozoa have traditionally been divided on the basis of their means of locomotion, although this is no longer believed to represent genuine relationships:

- * Flagellates (e.g. *Giardia lamblia*)
- * Amoeboids (e.g. *Entamoeba histolytica*)
- * Sporozoans (e.g. *Plasmodium knowlesi*)
- * Apicomplexa
- * Myxozoa
- * Microsporidia
- * Ciliates (e.g. *Balantidium coli*)

There are many ways that infectious diseases can spread. Pathogens usually have specific routes by which they are transmitted, and these routes may depend on the type of cells and tissue that a particular agent targets. For example, because cold viruses infect the respiratory tract, they are dispersed into the air via coughing and sneezing.

Once in the air, the viruses can infect another person who is unlucky enough to inhale air containing the virus particles.

Agents vary greatly in their stability in the environment. Some viruses may survive for only a few minutes outside of a host, while some spore-forming bacteria are extremely durable and may survive in a dormant state for a decade or more.

Protozoa Section

EUGLENA

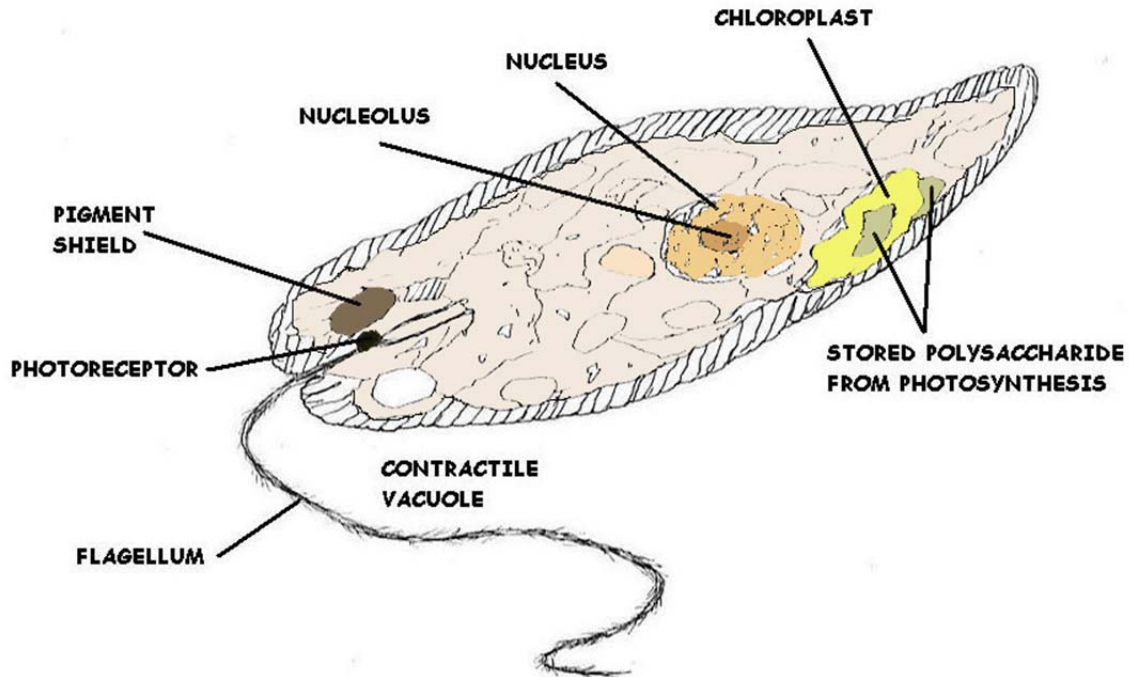

The diverse assemblage of organisms that carry out all of their life functions within the confines of a single, complex eukaryotic cell are called protozoa.

Paramecium, Euglena, and Amoeba are well-known examples of these major groups of organisms. Some protozoa are more closely related to animals, others to plants, and still others are relatively unique. Although it is not appropriate to group them together into a single taxonomic category, the research tools used to study any unicellular organism are usually the same, and the field of protozoology has been created to carry out this research. The unicellular photosynthetic protozoa are sometimes also called algae and are addressed elsewhere. This report considers the status of our knowledge of heterotrophic protozoa (protozoa that cannot produce their own food).

Free-living Protozoa

Protozoans are found in all moist habitats within the United States, but we know little about their specific geographic distribution. Because of their small size, production of resistant cysts, and ease of distribution from one place to another, many species appear to be cosmopolitan and may be collected in similar microhabitats worldwide (Cairns and Ruthven 1972). Other species may have relatively narrow limits to their distribution.

Marine ciliates inhabit interstices of sediment and beach sands, surfaces, deep sea and cold Antarctic environments, planktonic habitats, and the algal mats and detritus of estuaries and wetlands.

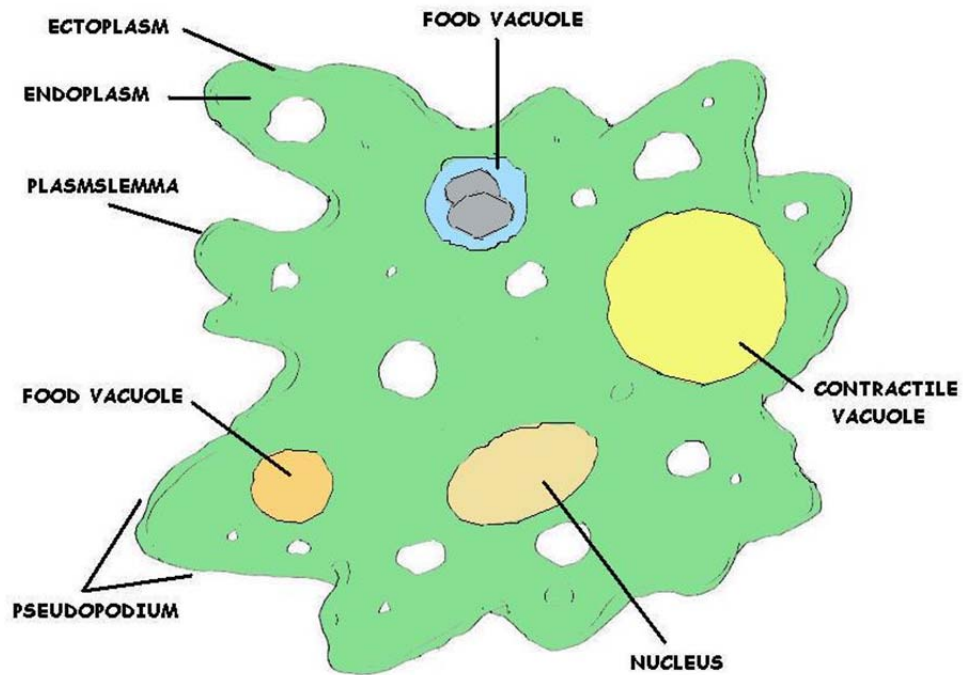

AMOEBIA



***Amoeba proteus*, pseudopods slowly engulf the small desmid *Staurastrum*.**

Amoebas

Amoebas (Phylum Rhizopoda) are unicellular protists that are able to change their shape constantly. Each species has its own distinct repertoire of shapes.

How does an amoeba locomote?

Amoebas locomote by way of cytoplasmic movement. (cytoplasm is the cell content around the nucleus of the cell) The amoeba forms pseudopods (false feet) with which they 'flow' over a surface. The cytoplasm not only flows, it also changes from a fluid into a solid state.

These pseudopods are also used to capture prey, they simply engulf the food. They can detect the kind of prey and use different 'engulfing tactics'.

The image from the last page shows several cell organelles. Left from the center we can see aspherical water expelling vesicle and just right of it, the single nucleus of this species can be seen. Other species may have many nuclei. The cell is full of brown food vacuoles and also contains small crystals.

Protozoa Information

Our actual knowledge of salinity, temperature, and oxygen requirements of marine protozoa is poor (although some groups, such as the foraminifera, are better studied than others), and even the broadest outlines of their biogeographic ranges are usually a mystery. In general, freshwater protozoan communities are similar to marine communities except the specialized interstitial fauna of the sand is largely missing. In freshwater habitats, the foraminifera and radiolaria common in marine environments are absent or low in numbers while testate amoebae exist in greater numbers. Relative abundance of species in the marine versus freshwater habitat is unknown.

Soil-dwelling protozoa have been documented from almost every type of soil and in every kind of environment, from the peat-rich soil of bogs to the dry sands of deserts. In general, protozoa are found in greatest abundance near the soil surface, especially in the upper 15 cm (6 in), but occasional isolates can be obtained at depths of a meter (yard) or more.

Protozoa do not constitute a major part of soil biomass, but in some highly productive regions such as forest litter, the protozoa are a significant food source for the microinvertebrates, with a biomass that may reach 20 g/m² of soil surface area there.

Environmental Quality Indicators

Polluted waters often have a rich and characteristic protozoan fauna. The relative abundance and diversity of protozoa are used as indicators of organic and toxic pollution (Cairns et al. 1972; Foissner 1987; Niederlehner et al. 1990; Curds 1992). Bick (1972), for example, provided a guide to ciliates that are useful as indicators of environmental quality of European freshwater systems, along with their ecological distribution with respect to parameters such as amount of organic material and oxygen levels.

Foissner (1988) clarified the taxonomy of European ciliates as part of a system for classifying the state of aquatic habitats according to their faunas.

Symbiotic Protozoa Parasites

Protozoa are infamous for their role in causing disease, and parasitic species are among the best-known protozoa. Nevertheless, our knowledge has large gaps, especially of normally free-living protozoa that may become pathogenic in immunocompromised individuals. For example, microsporidia comprise a unique group of obligate, intracellular parasitic protozoa. Microsporidia are amazingly diverse organisms with more than 700 species and 80 genera that are capable of infecting a variety of plant, animal, and even other protist hosts.

They are found worldwide and have the ability to thrive in many ecological conditions. Until the past few years, their ubiquity did not cause a threat to human health, and few systematists worked to describe and classify the species. Since 1985, however, physicians have documented an unusual rise in worldwide infections in AIDS patients caused by four different genera of microsporidia (Encephalitozoon, Nosema, Pleistophora, and Enterocytozoon). According to the Centers for Disease Control in the United States, difficulties in identifying microsporidian species are impeding diagnosis and effective treatment of AIDS patients.

Protozoan Reservoirs of Disease

The presence of bacteria in the cytoplasm of protozoa is well known, whereas that of viruses is less frequently reported. Most of these reports simply record the presence of bacteria or viruses and assume some sort of symbiotic relationship between them and the protozoa. Recently, however, certain human pathogens were shown to not only survive but also to multiply in the cytoplasm of free-living, nonpathogenic protozoa. Indeed, it is now believed that protozoa are the natural habitat for certain pathogenic bacteria. To date, the main focus of attention has been on the bacterium *Legionella pneumophila*, the causative organism of Legionnaires' disease; these bacteria live and reproduce in the cytoplasm of some free-living amoebae (Curds 1992). More on this subject in the following pages.

Symbionts

Some protozoa are harmless or even beneficial symbionts. A bewildering array of ciliates, for example, inhabit the rumen and reticulum of ruminates and the cecum and colon of equids. Little is known about the relationship of the ciliates to their host, but a few may aid the animal in digesting cellulose.

Data on Protozoa

While our knowledge of recent and fossil foraminifera in the U.S. coastal waterways is systematically growing, other free-living protozoa are poorly known. There are some regional guides and, while some are excellent, many are limited in scope, vague on specifics, or difficult to use. Largely because of these problems, most ecologists who include protozoa in their studies of aquatic habitats do not identify them, even if they do count and measure them for biomass estimates (Taylor and Sanders 1991).

Parasitic protozoa of humans, domestic animals, and wildlife are better known although no attempt has been made to compile this information into a single source. Large gaps in our knowledge exist, especially for haemogregarines, microsporidians, and myxosporidians (see Kreier and Baker 1987).

Museum Specimens

For many plant and animal taxa, museums represent a massive information resource. This is not true for protozoa. In the United States, only the National Natural History Museum (Smithsonian Institution) has a reference collection preserved on microscope slides, but it does not have a protozoologist curator and cannot provide species' identification or verification services. The American Type Culture Collection has some protozoa in culture, but its collection includes relatively few kinds of protozoa.

Ecological Role of Protozoa

Although protozoa are frequently overlooked, they play an important role in many communities where they occupy a range of trophic levels. As predators upon unicellular or filamentous algae, bacteria, and microfungi, protozoa play a role both as herbivores and as consumers in the decomposer link of the food chain. As components of the micro- and meiofauna, protozoa are an important food source for microinvertebrates. Thus, the ecological role of protozoa in the transfer of bacterial and algal production to successive trophic levels is important.

Factors Affecting Growth and Distribution

Most free-living protozoa reproduce by cell division (exchange of genetic material is a separate process and is not involved in reproduction in protozoa). The relative importance for population growth of biotic versus chemical-physical components of the environment is difficult to ascertain from the existing survey data. Protozoa are found living actively in nutrient-poor to organically rich waters and in fresh water varying between 0°C (32°F) and 50°C (122°F). Nonetheless, it appears that rates of population growth increase when food is not constrained and temperature is increased (Lee and Fenchel 1972; Fenchel 1974; Montagnes et al. 1988).

Comparisons of oxygen consumption in various taxonomic groups show wide variation (Laybourn and Finlay 1976), with some aerobic forms able to function at extremely low oxygen tensions and to thereby avoid competition and predation.

Many parasitic and a few free-living species are obligatory anaerobes (grow without atmospheric oxygen). Of the free-living forms, the best known are the plagiopylid ciliates that live in the anaerobic sulfide-rich sediments of marine wetlands (Fenchel et al. 1977). The importance of plagiopylids in recycling nutrients to aerobic zones of wetlands is potentially great.

Because of the small size of protozoa, their short generation time, and (for some species) ease of maintaining them in the laboratory, ecologists have used protozoan populations and communities to investigate competition and predation.

The result has been an extensive literature on a few species studied primarily under laboratory conditions. Few studies have been extended to natural habitats with the result that we know relatively little about most protozoa and their roles in natural communities. Intraspecific competition for common resources often results in cannibalism, sometimes with dramatic changes in morphology of the cannibals (Giese 1973). Field studies of interspecific competition are few and most evidence for such species interactions is indirect (Cairns and Yongue 1977).

Contractile Vacuoles

Many protozoa have contractile vacuoles, which collect and expel excess water, and extrusomes, which expel material used to deflect predators or capture prey. In multicellular organisms, hormones are often produced in vesicles. In higher plants, most of a cell's volume is taken up by a central vacuole or tonoplast, which maintains its osmotic pressure. Many eukaryotes have slender motile projections, usually called flagella when long and cilia when short. These are variously involved in movement, feeding, and sensation. These are entirely distinct from prokaryotic flagella. They are supported by a bundle of microtubules arising from a basal body, also called a kinetosome or centriole, characteristically arranged as nine doublets surrounding two singlets. Flagella also may have hairs or mastigonemes, scales, connecting membranes, and internal rods. Their interior is continuous with the cell's cytoplasm.

Centrioles

Centrioles are often present even in cells and groups that do not have flagella. They generally occur in groups of one or two, called kinetids that give rise to various microtubular roots. These form a primary component of the cytoskeletal structure, and are often assembled over the course of several cell divisions, with one flagellum retained from the parent and the other derived from it. Centrioles may also be associated in the formation of a spindle during nuclear division. Some protists have various other microtubule-supported organelles. These include the radiolaria and heliozoa, which produce axopodia used in flotation or to capture prey, and the haptophytes, which have a peculiar flagellum-like organelle called the haptonema.

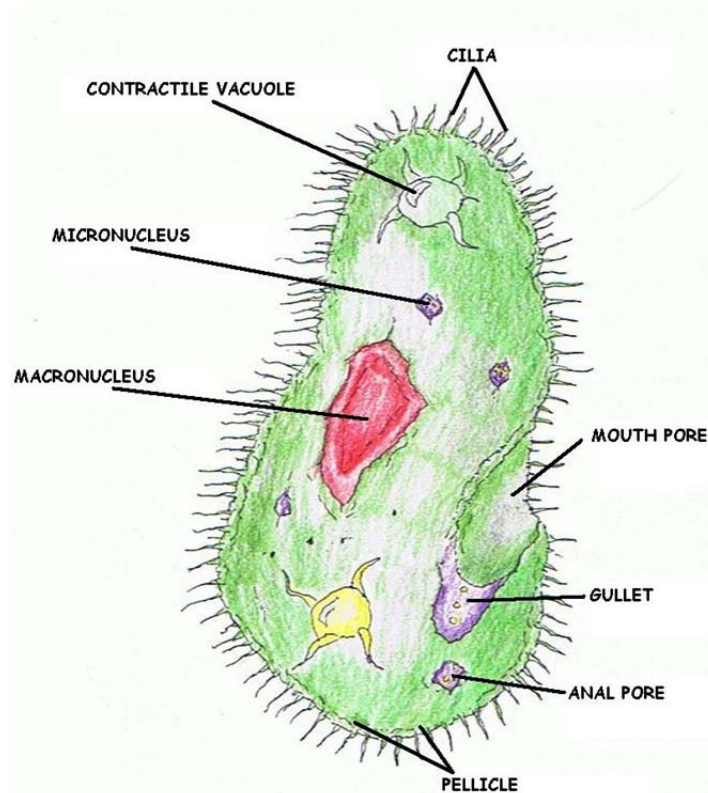

Figure 1. A diagram of *Paramecium* sp. with major organelles indicated.



Contractile Vacuoles

Figure 2. The contractile vacuole when full (top) and after contraction (bottom).

Paramecium

Members of the genus *Paramecium* are single-celled, freshwater organisms in the kingdom Protista. They exist in an environment in which the osmotic concentration in their external environment is much lower than that in their cytoplasm. More specifically, the habitat in which they live is **hypotonic** to their cytoplasm. As a result of this, *Paramecium* is subjected to a continuous influx of water, as water diffuses inward to a region of higher osmotic concentration.

If *Paramecium* is to maintain homeostasis, water must be continually pumped out of the cell (against the osmotic gradient) at the same rate at which it moves in. This process, known as **osmoregulation**, is carried out by two organelles in *Paramecium* known as **contractile vacuoles** (Figures 1 and 2).

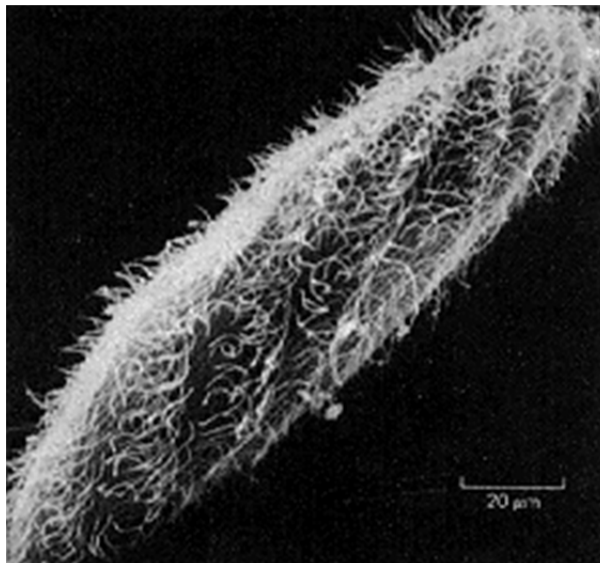

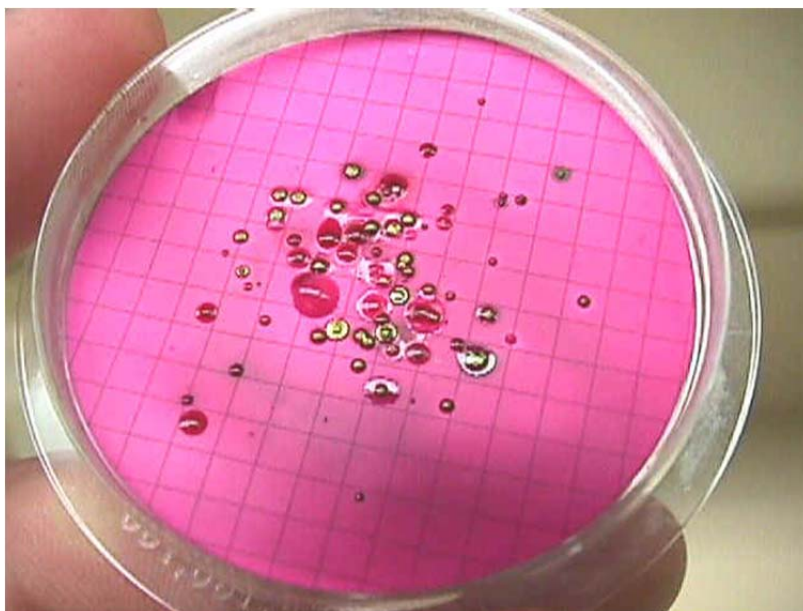

Coliform Bacteria on a Petri Dish. Bottom photo, SimPlate for HPC counts. IDEXX's SimPlate for HPC method is used for the quantification of heterotrophic plate count (HPC) in water. It is based on the Multiple Enzyme Technology which detects viable bacteria in water by testing for the presence of key enzymes known to be present in these little organisms. This technique uses enzyme substrates that produce a blue fluorescence when metabolized by waterborne bacteria. The sample and media are added to a SimPlate Plate, incubated and then examined for fluorescing wells. The number of wells corresponds to a Most Probable Number (MPN) of total bacteria in the original sample. The MPN values generated by the SimPlate for HPC method correlate with the Pour Plate method using the Total Plate Count Agar incubated at 35°C for 48 hours as described in *Standard Methods for the Examination of Water and Wastewater, 19th Edition*.



Protozoan Diseases

Protozoan pathogens are larger than bacteria and viruses, but still microscopic. They invade and inhabit the gastrointestinal tract. Some parasites enter the environment in a dormant form, with a protective cell wall called a “**cyst**.” The cyst can survive in the environment for long periods of time and be extremely resistant to conventional disinfectants such as chlorine. Effective filtration treatment is therefore critical to removing these organisms from water sources.

Giardiasis

Giardiasis is a commonly reported protozoan-caused disease. It has also been referred to as “**backpacker’s disease**” and “**beaver fever**” because of the many cases reported among hikers and others who consume untreated surface water. Symptoms include chronic diarrhea, abdominal cramps, bloating, frequent loose and pale greasy stools, fatigue and weight loss. The incubation period is 5-25 days or longer, with an average of 7-10 days. Many infections are asymptomatic (no symptoms). Giardiasis occurs worldwide. Waterborne outbreaks in the United States occur most often in communities receiving their drinking water from streams or rivers without adequate disinfection or a filtration system. The organism, *Giardia lamblia*, has been responsible for more community-wide outbreaks of disease in the U.S. than any other pathogen. Drugs are available for treatment but are not 100% effective.

Cryptosporidiosis

Cryptosporidiosis is an example of a protozoan disease that is common worldwide, but was only recently recognized as causing human disease. The major symptom in humans is diarrhea, which may be profuse and watery. The diarrhea is associated with cramping abdominal pain. General malaise, fever, anorexia, nausea, and vomiting occur less often. Symptoms usually come and go, and end in fewer than 30 days in most cases. The incubation period is 1-12 days, with an average of about seven days. *Cryptosporidium* organisms have been identified in human fecal specimens from more than 50 countries on six continents. The mode of transmission is fecal-oral, either by person-to-person or animal-to-person. There is no specific treatment for *Cryptosporidium* infections.

All of these diseases, with the exception of hepatitis A, have one symptom in common: diarrhea. They also have the same mode of transmission, fecal-oral, whether through person-to-person or animal-to-person contact, and the same routes of transmission, being either foodborne or waterborne. Although most pathogens cause mild, self-limiting disease, on occasion, they can cause serious, even life threatening illness. Particularly vulnerable are persons with weak immune systems such as those with HIV infections or cancer. By understanding the nature of waterborne diseases, the importance of properly constructed, operated and maintained public water systems becomes obvious. While water treatment cannot achieve sterile water (no microorganisms), the goal of treatment must clearly be to produce drinking water that is as pathogen-free as possible at all times. For those who operate water systems with inadequate source protection or treatment facilities, the potential risk of a waterborne disease outbreak is real. For those operating systems that currently provide adequate source protection and treatment, operating and maintaining the system at a high level on a continuing basis is critical to prevent disease.

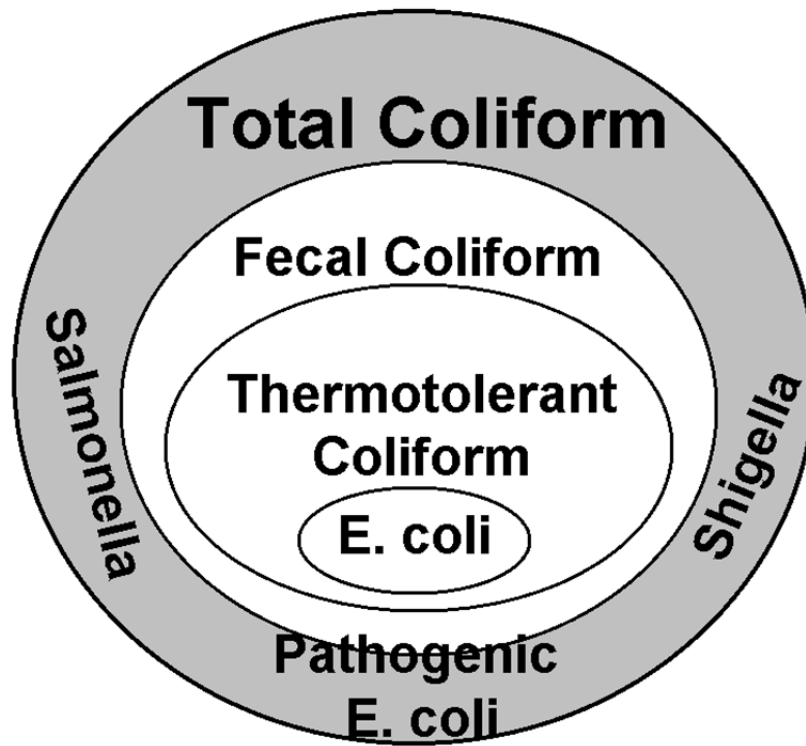
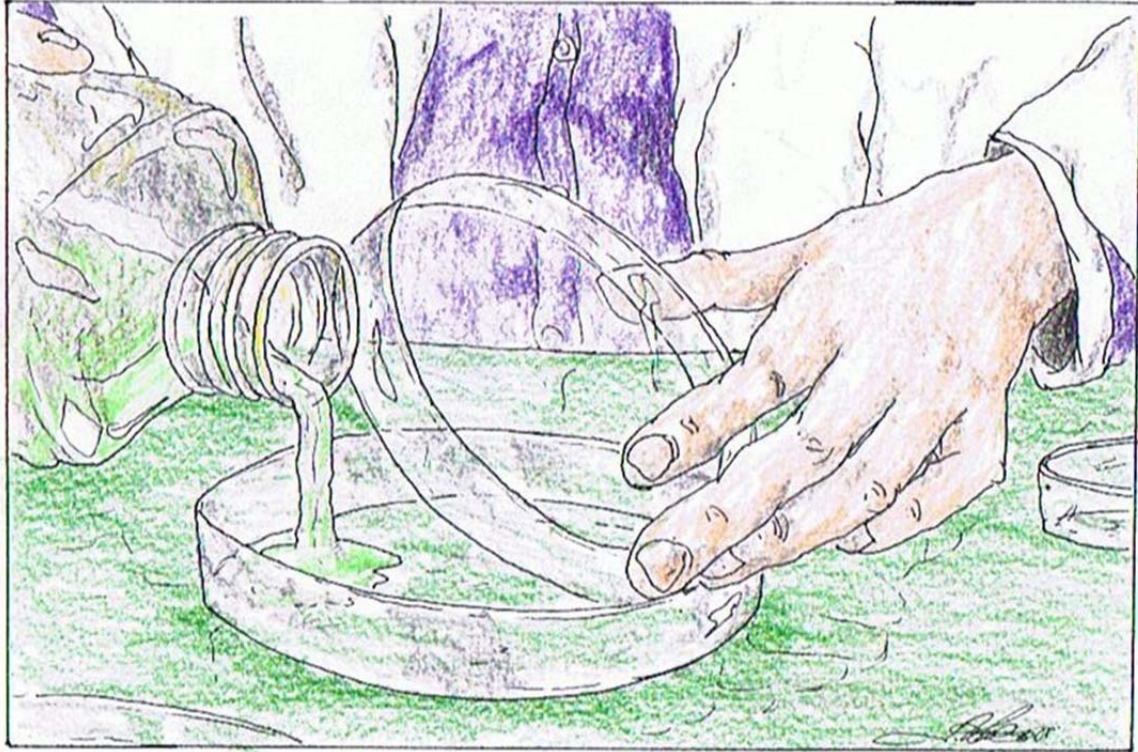

Giardia Lamblia

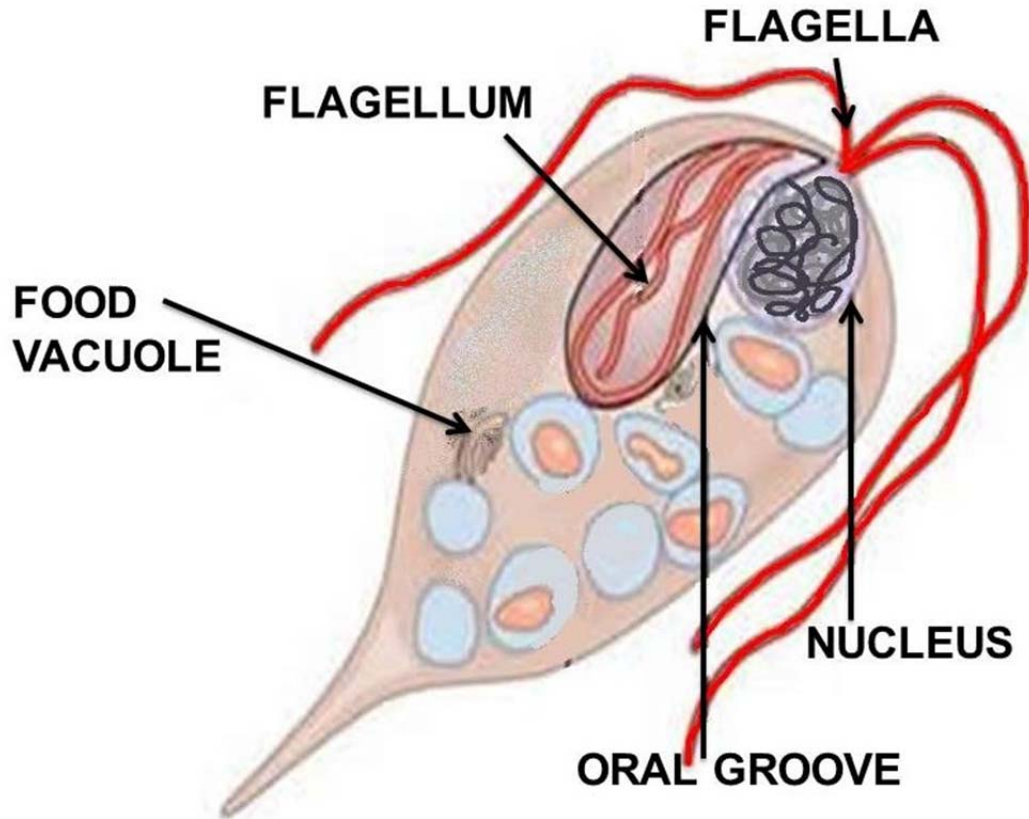

GIARDIA LAMBLIA

Giardia lamblia (synonymous with *Lamblia intestinalis* and *Giardia duodenalis*) is a flagellated protozoan parasite that colonizes and reproduces in the small intestine, causing giardiasis. The giardia parasite attaches to the epithelium by a ventral adhesive disc, and reproduces via binary fission. Giardiasis does not spread via the bloodstream, nor does it spread to other parts of the gastro-intestinal tract, but remains confined to the lumen of the small intestine. Giardia trophozoites absorb their nutrients from the lumen of the small intestine, and are anaerobes.

Giardia infection can occur through ingestion of dormant cysts in contaminated water, or by the fecal-oral route (through poor hygiene practices). The Giardia cyst can survive for weeks to months in cold water and therefore can be present in contaminated wells and water systems, and even clean-looking mountain streams, as well as city reservoirs, as the Giardia cysts are resistant to conventional water treatment methods, such as chlorination and ozonolysis. Zoonotic transmission is also possible, and therefore Giardia infection is a concern for people camping in the wilderness or swimming in contaminated streams or lakes, especially the artificial lakes formed by beaver dams (hence the popular name for giardiasis, "Beaver Fever"). As well as water-borne sources, fecal-oral transmission can also occur, for example in day care centers, where children may have poorer hygiene practices.

Those who work with children are also at risk of being infected, as are family members of infected individuals. Not all Giardia infections are symptomatic, so some people can unknowingly serve as carriers of the parasite.

The life cycle begins with a non-infective cyst being excreted with feces of an infected individual. Once out in the environment, the cyst becomes infective. A distinguishing characteristic of the cyst is 4 nuclei and a retracted cytoplasm. Once ingested by a host, the trophozoite emerges to an active state of feeding and motility. After the feeding stage, the trophozoite undergoes asexual replication through longitudinal binary fission. The resulting trophozoites and cysts then pass through the digestive system in the feces. While the trophozoites may be found in the feces, only the cysts are capable of surviving outside of the host.

Distinguishing features of the trophozoites are large karyosomes and lack of peripheral chromatin, giving the two nuclei a halo appearance. Cysts are distinguished by a retracted cytoplasm. This protozoa lacks mitochondria, although the discovery of the presence of mitochondrial remnant organelles in one recent study "indicate that Giardia is not primitively amitochondrial and that it has retained a functional organelle derived from the original mitochondrial endosymbiont"

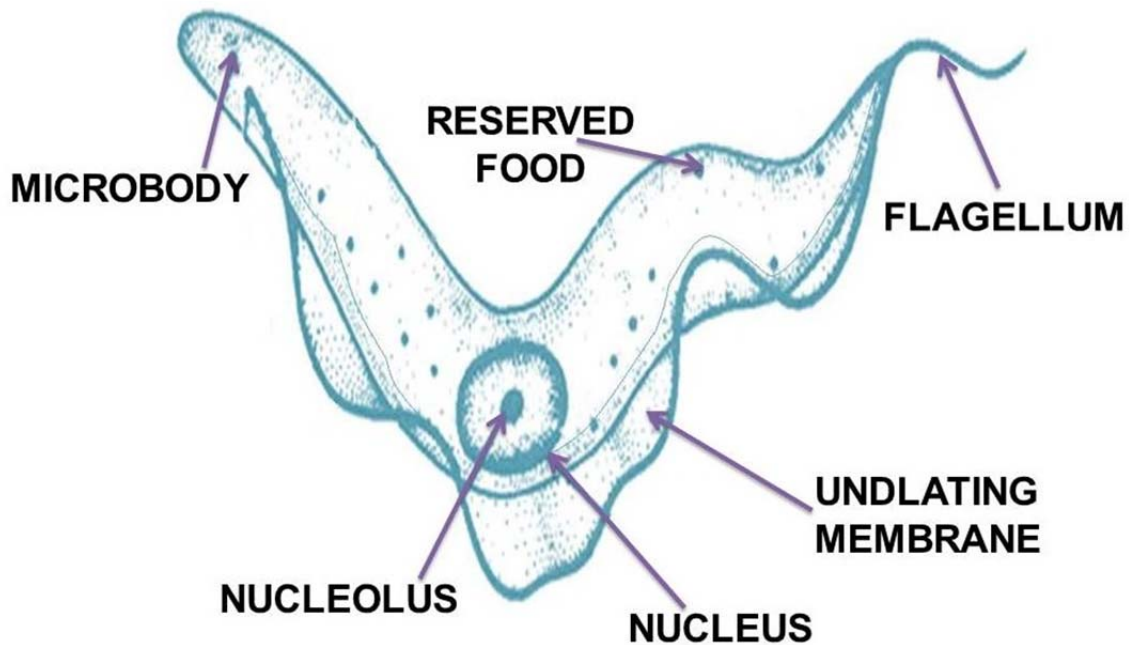

PROTOZOAN PARASITE

Cryptosporidium

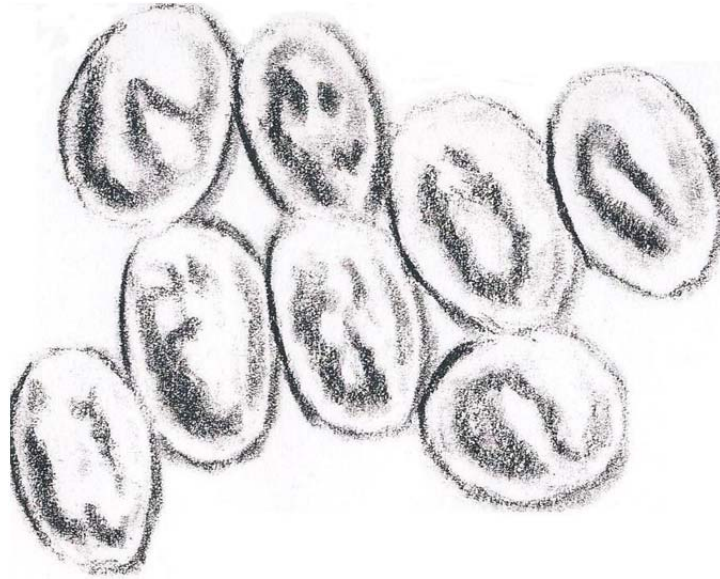

Cryptosporidium is a protozoan pathogen of the Phylum Apicomplexa and causes a diarrheal illness called cryptosporidiosis. Other apicomplexan pathogens include the malaria parasite Plasmodium, and Toxoplasma, the causative agent of toxoplasmosis. Unlike Plasmodium, which transmits via a mosquito vector, Cryptosporidium does not utilize an insect vector and is capable of completing its life cycle within a single host, resulting in cyst stages which are excreted in feces and are capable of transmission to a new host.

A number of species of Cryptosporidium infect mammals. In humans, the main causes of disease are *C. parvum* and *C. hominis* (previously *C. parvum* genotype 1). *C. canis*, *C. felis*, *C. meleagridis*, and *C. muris* can also cause disease in humans. In recent years, cryptosporidiosis has plagued many commercial Leopard gecko breeders. Several species of the Cryptosporidium family (*C. serpentes* and others) are involved, and outside of geckos it has been found in monitor lizards, iguanas, tortoises as well as several snake species.

Cryptosporidiosis is typically an acute short-term infection but can become severe and non-resolving in children and immunocompromised individuals. The parasite is transmitted by environmentally hardy cysts (oocysts) that, once ingested, excyst in the small intestine and result in an infection of intestinal epithelial tissue.

The genome of *Cryptosporidium parvum* was sequenced in 2004 and was found to be unusual amongst Eukaryotes in that the mitochondria seem not to contain DNA. A closely-related species, *C. hominis*, also has its genome sequence available. CryptoDB.org is a NIH-funded database that provides access to the *Cryptosporidium* genomics data sets.

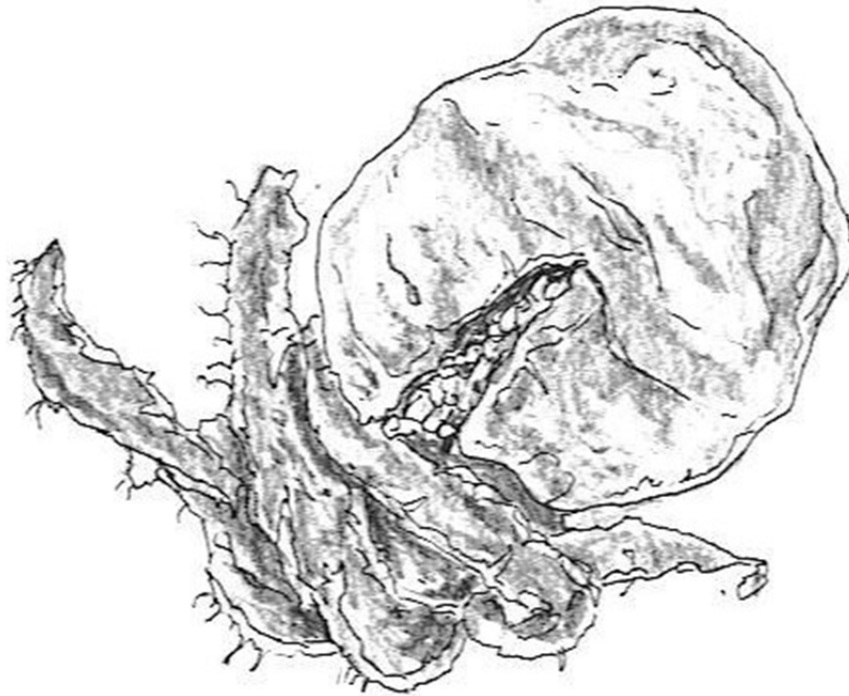

CRYPTO-PARVUM

When *C. parvum* was first identified as a human pathogen, diagnosis was made by a biopsy of intestinal tissue (Keusch, *et al.*, 1995). However, this method of testing can give false negatives due to the "patchy" nature of the intestinal parasitic infection (Flanigan and Soave, 1993). Staining methods were then developed to detect and identify the oocysts directly from stool samples. The modified acid-fast stain is traditionally used to most reliably and specifically detect the presence of cryptosporidial oocysts.

There have been six major outbreaks of cryptosporidiosis in the United States as a result of contamination of drinking water (Juraneck, 1995). One major outbreak in Milwaukee in 1993 affected over 400,000 persons. Outbreaks such as these usually result from drinking water taken from surface water sources such as lakes and rivers (Juraneck, 1995). Swimming pools and water park wave pools have also been associated with outbreaks of cryptosporidiosis. Also, untreated groundwater or well water public drinking water supplies can be sources of contamination.

The highly environmentally resistant cyst of *C. parvum* allows the pathogen to survive various drinking water filtrations and chemical treatments such as chlorination. Although municipal drinking water utilities may meet federal standards for safety and quality of drinking water, complete protection from cryptosporidial infection is not guaranteed. In fact, *all* waterborne outbreaks of cryptosporidiosis have occurred in communities where the local utilities met all state and federal drinking water standards (Juraneck, 1995).

Entamoeba histolytica

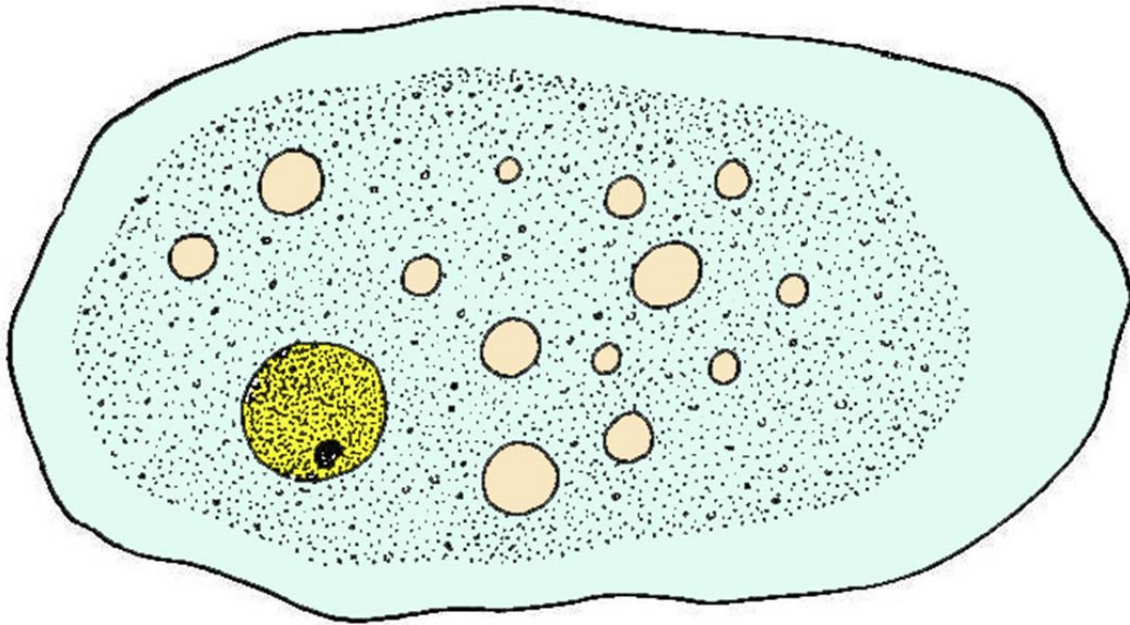

Entamoeba histolytica, another water-borne pathogen, can cause diarrhea or a more serious invasive liver abscess. When in contact with human cells, these amoebae are cytotoxic. There is a rapid influx of calcium into the contacted cell, it quickly stops all membrane movement save for some surface blebbing. Internal organization is disrupted, organelles lyse, and the cell dies. The amoeba may eat the dead cell or just absorb nutrients released from the cell.

On average, about one in 10 people who are infected with *E. histolytica* becomes sick from the infection. The symptoms often are quite mild and can include loose stools, stomach pain, and stomach cramping. Amebic dysentery is a severe form of amebiasis associated with stomach pain, bloody stools, and fever. Rarely, *E. histolytica* invades the liver and forms an abscess. Even less commonly, it spreads to other parts of the body, such as the lungs or brain.

Scientific classification

Domain: Eukaryota
Phylum: Amoebozoa
Class: Archamoebae
Genus: *Entamoeba*
Species: *E. histolytica*

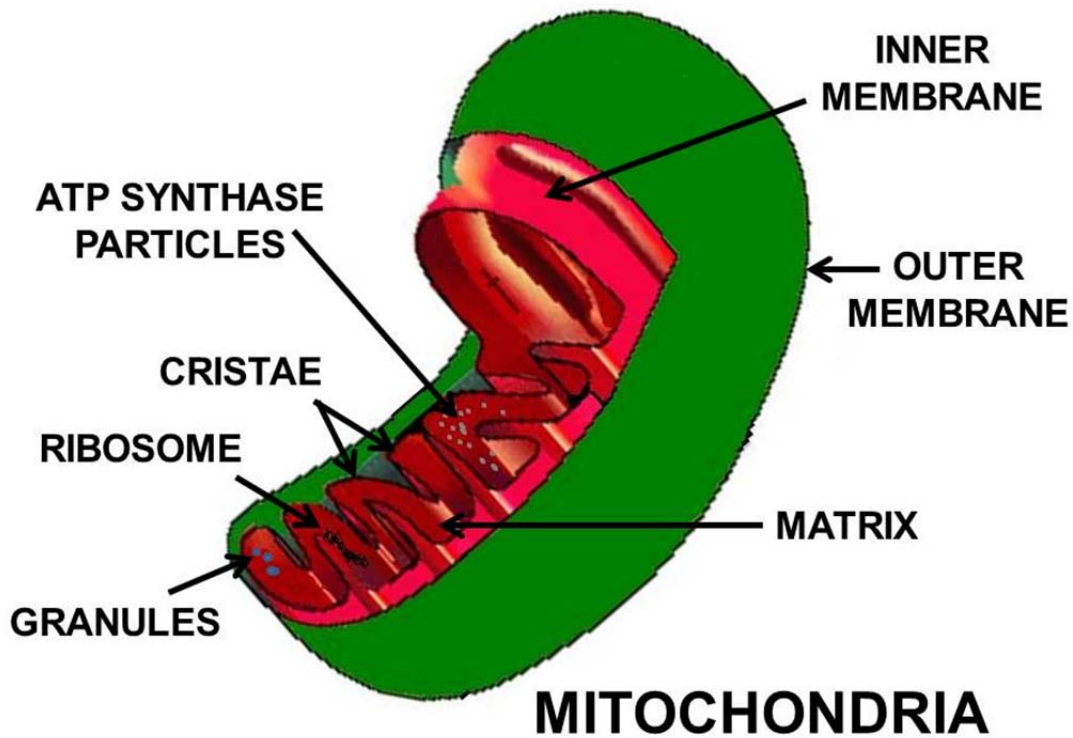

Mitochondria

The bacterial cell is surrounded by a lipid membrane, or cell membrane, which encloses the contents of the cell and acts as a barrier to hold nutrients, proteins and other essential components of the cytoplasm within the cell. As they are prokaryotes, bacteria do not tend to have membrane-bound organelles in their cytoplasm and thus contain few large intracellular structures. They consequently lack a nucleus, mitochondria, chloroplasts and the other organelles present in eukaryotic cells, such as the Golgi apparatus and endoplasmic reticulum.

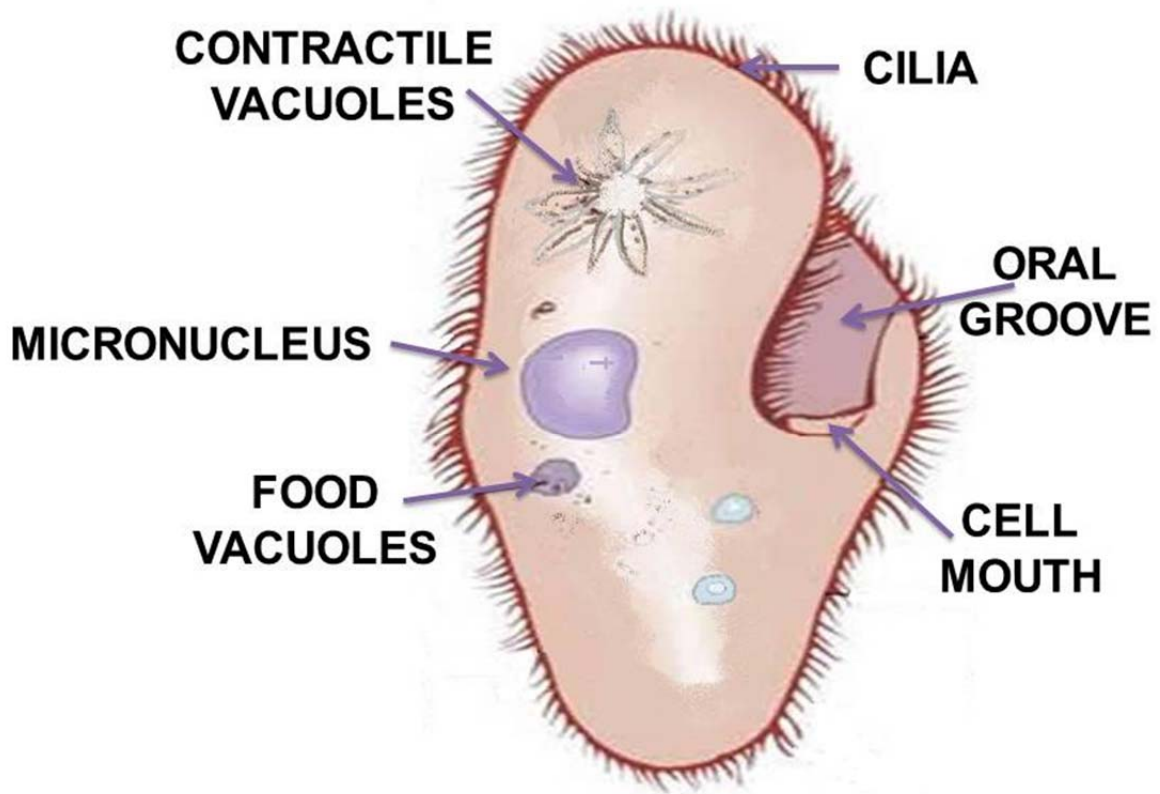

PARAMECIUM

Paramecia

Paramecia are a group of unicellular ciliate protozoa formerly known as slipper animalcules from their slipper shape. They are commonly studied as a representative of the ciliate group. Simple cilia cover the body which allows the cell to move with a synchronous motion (like a caterpillar). There is also a deep oral groove containing inconspicuous compound oral cilia (as found in other peniculids) that is used to draw food inside. They generally feed upon bacteria and other small cells. Osmoregulation is carried out by a pair of contractile vacuoles, which actively expel water absorbed by osmosis from their surroundings. Paramecia are widespread in freshwater environments, and are especially common in scums. Paramecia are attracted by acidic conditions. Certain single-celled eukaryotes, such as Paramecium, are examples for exceptions to the universality of the genetic code (translation systems where a few codons differ from the standard ones).

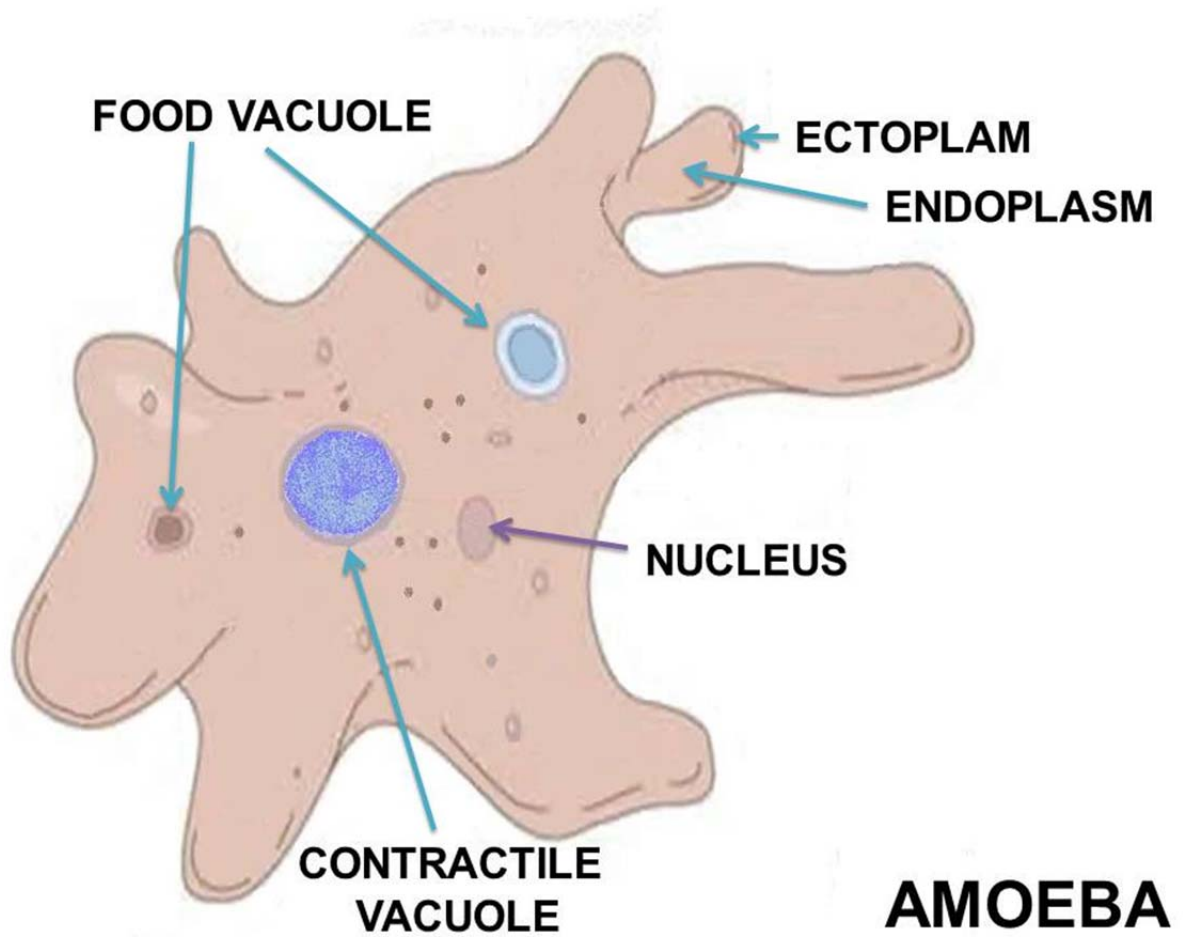

Amoeba

Amoeba (sometimes amœba or ameba, plural amoebae) is a genus of protozoa that moves by means of pseudopods, and is well-known as a representative unicellular organism. The word amoeba or ameba is variously used to refer to it and its close relatives, now grouped as the Amoebozoa, or to all protozoa that move using pseudopods, otherwise termed amoeboids.

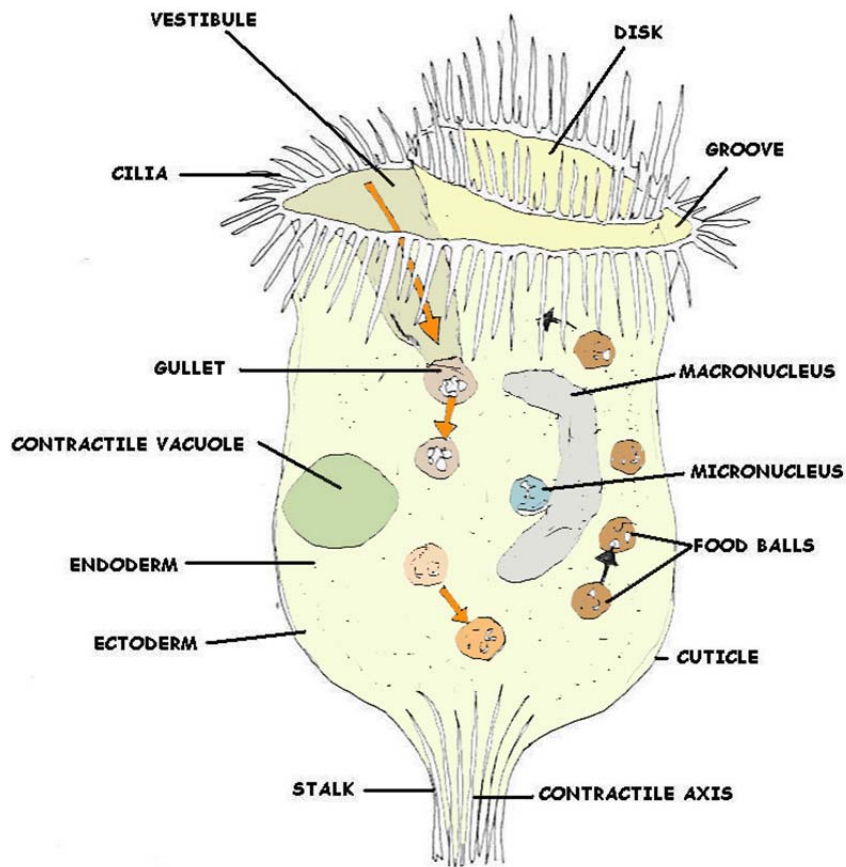

VORTICELLA

(TYPE OF PROTOZOAN FOUND IN STAGNANT WATER)

Vorticella

Vorticella is a genus of protozoa, with over 100 known species. They are stalked inverted bell-shaped ciliates, placed among the peritrichs. Each cell has a separate stalk anchored onto the substrate, which contains a contractile fibril called a myoneme. When stimulated this shortens, causing the stalk to coil like a spring. Reproduction is by budding, where the cell undergoes longitudinal fission and only one daughter keeps the stalk. Vorticella mainly lives in freshwater ponds and streams - generally anywhere protists are plentiful. Other genera such as Carchesium resemble Vorticella but are branched or colonial.

Domain: Eukaryota
Phylum: Ciliophora
Class: Oligohymenophorea
Subclass: Peritrichia
Order: Sessilida
Family: Vorticellidae
Genus: Vorticella

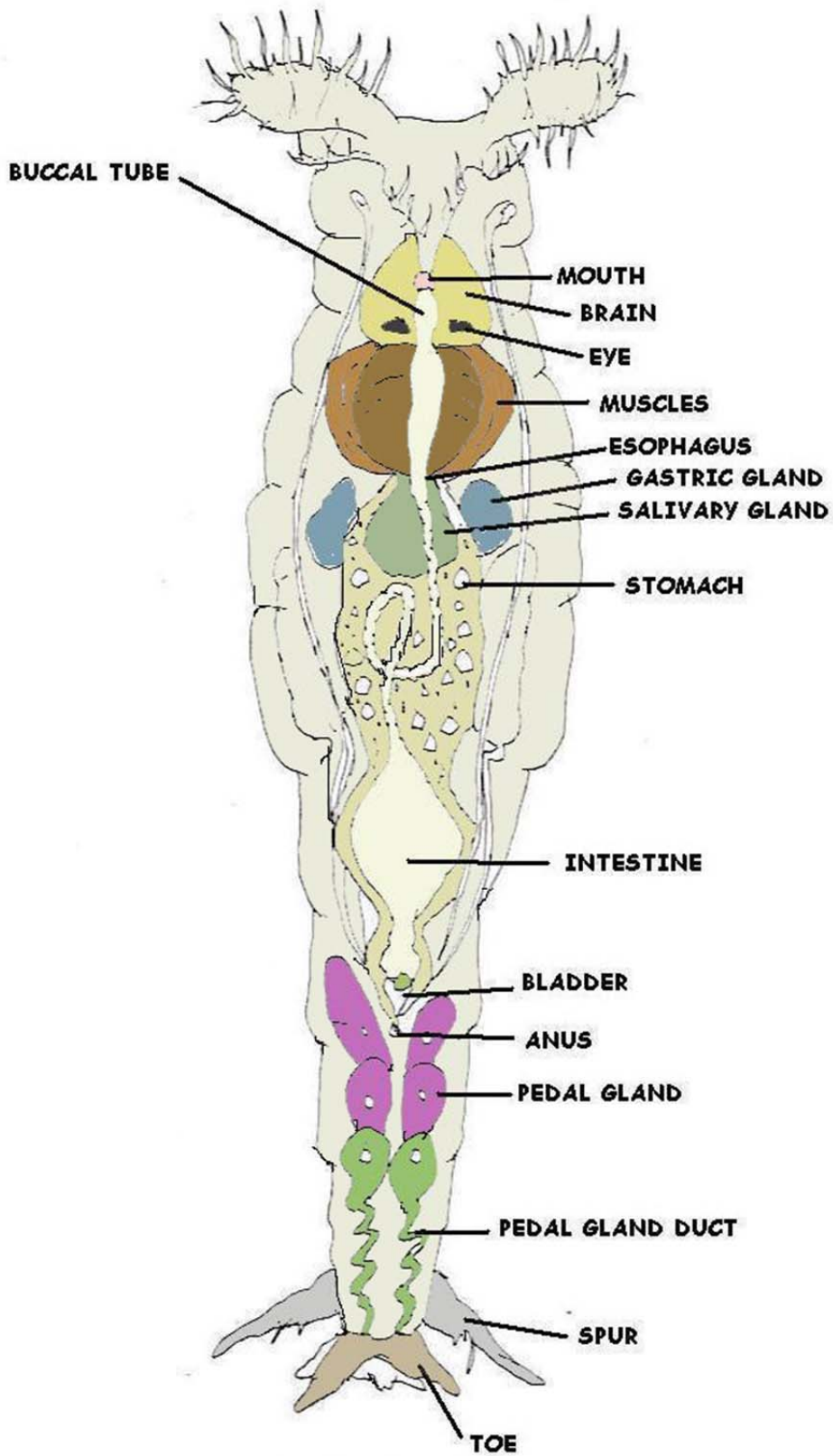

ROTIFER

Rotifer

The rotifers make up a phylum of microscopic and near-microscopic pseudocoelomate animals. They were first described by John Harris in 1696 (Hudson and Gosse, 1886). Leeuwenhoek is mistakenly given credit for being the first to describe rotifers but Harris had produced sketches in 1703. Most rotifers are around 0.1-0.5 mm long, and are common in freshwater throughout the world with a few saltwater species. Rotifers may be free swimming and truly planktonic, others move by inch worming along the substrate, whilst some are sessile, living inside tubes or gelatinous holdfasts. About 25 species are colonial (e.g. *Sinantherina semibullata*), either sessile or planktonic.

Rotifers get their name (derived from Greek and meaning "wheel-bearer"; they have also been called wheel animalcules) from the corona, which is composed of several ciliated tufts around the mouth that in motion resemble a wheel. These create a current that sweeps food into the mouth, where it is chewed up by a characteristic pharynx (called the mastax) containing a tiny, calcified, jaw-like structure called the trophi. The cilia also pull the animal, when unattached, through the water. Most free-living forms have pairs of posterior toes to anchor themselves while feeding. Rotifers have bilateral symmetry and a variety of different shapes. There is a well-developed cuticle which may be thick and rigid, giving the animal a box-like shape, or flexible, giving the animal a worm-like shape; such rotifers are respectively called loricate and illoricate.

Like many other microscopic animals, adult rotifers frequently exhibit eutely - they have a fixed number of cells within a species, usually on the order of one thousand. Males in the class Monogononta may be either present or absent depending on the species and environmental conditions. In the absence of males, reproduction is by parthenogenesis and results in clonal offspring that are genetically identical to the parent. Individuals of some species form two distinct types of parthenogenetic eggs; one type develops into a normal parthenogenetic female, while the other occurs in response to a changed environment and develops into a degenerate male that lacks a digestive system, but does have a complete male reproductive system that is used to inseminate females thereby producing fertilized 'resting eggs'. Resting eggs develop into zygotes that are able to survive extreme environmental conditions such as may occur during winter or when the pond dries up. These eggs resume development and produce a new female generation when conditions improve again. The life span of monogonont females varies from a couple of days to about three weeks.

Bdelloid rotifers are unable to produce resting eggs, but many can survive prolonged periods of adverse conditions after desiccation. This facility is termed anhydrobiosis, and organisms with these capabilities are termed anhydrobionts. Under drought conditions, bdelloid rotifers contract into an inert form and lose almost all body water; when rehydrated, however, they resume activity within a few hours. Bdelloids can survive the dry state for prolonged periods, with the longest well-documented dormancy being nine years. While in other anhydrobionts, such as the brine shrimp, this desiccation tolerance is thought to be linked to the production of trehalose, a non-reducing disaccharide (sugar), bdelloids apparently lack the ability to synthesize trehalose. Bdelloid rotifer genomes contain two or more divergent copies of each gene. Four copies of *hsp82* are, for example, found. Each is different and found on a different chromosome, excluding the possibility of homozygous sexual reproduction.

Waterborne Diseases

Name	Causative organism	Source of organism	Disease
Viral gastroenteritis	Rotavirus (mostly in young children)	Human feces	Diarrhea or vomiting
Norwalk Agent	Noroviruses (genus <i>Norovirus</i> , family <i>Caliciviridae</i>) ^{*1}	Human feces; also, shellfish; lives in polluted waters	Diarrhea and vomiting
Salmonellosis	Salmonella (bacterium)	Animal or human feces	Diarrhea or vomiting
Gastroenteritis <i>Escherichia coli</i>	-- <i>E. coli</i> O157:H7 (bacterium): Other <i>E. coli</i> organisms:	Human feces	Symptoms vary with type caused
Typhoid	Salmonella typhi (bacterium)	Human feces, urine	Inflamed intestine, enlarged spleen, high temperature—sometimes fatal
Shigellosis	Shigella (bacterium)	Human feces	Diarrhea
Cholera	Vibrio cholerae (bacterium)	Human feces; also, shellfish; lives in many coastal waters	Vomiting, severe diarrhea, rapid dehydration, mineral loss—high mortality
Hepatitis A	Hepatitis A virus	Human feces; shellfish grown in polluted waters	Yellowed skin, enlarged liver, fever, vomiting, weight loss, abdominal pain—low mortality, lasts up to four months
Amebiasis	Entamoeba histolytica (protozoan)	Human feces	Mild diarrhea, dysentery, extra intestinal infection
Giardiasis	Giardia lamblia (protozoan)	Animal or human feces	Diarrhea, cramps, nausea, and general weakness — lasts one week to months
Cryptosporidiosis	Cryptosporidium parvum	Animal or human feces	Diarrhea, stomach pain — lasts (protozoan) days to weeks

Notes:

*1 <http://www.cdc.gov/ncidod/dvrd/revb/gastro/norovirus.htm>

<http://www.cdc.gov/mmwr/preview/mmwrhtml/rr5009a1.htm>

Bacteria Section

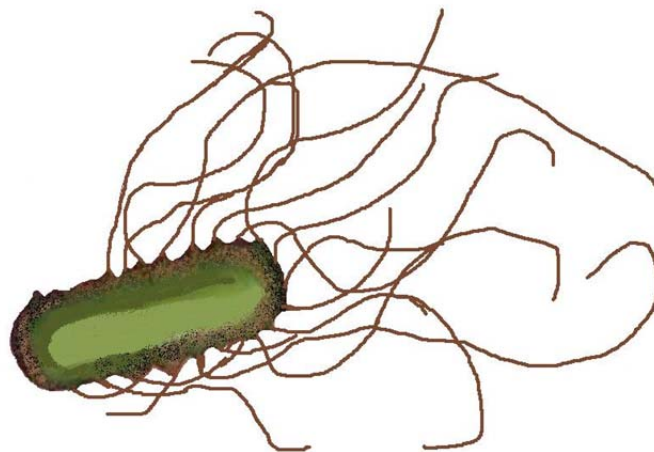
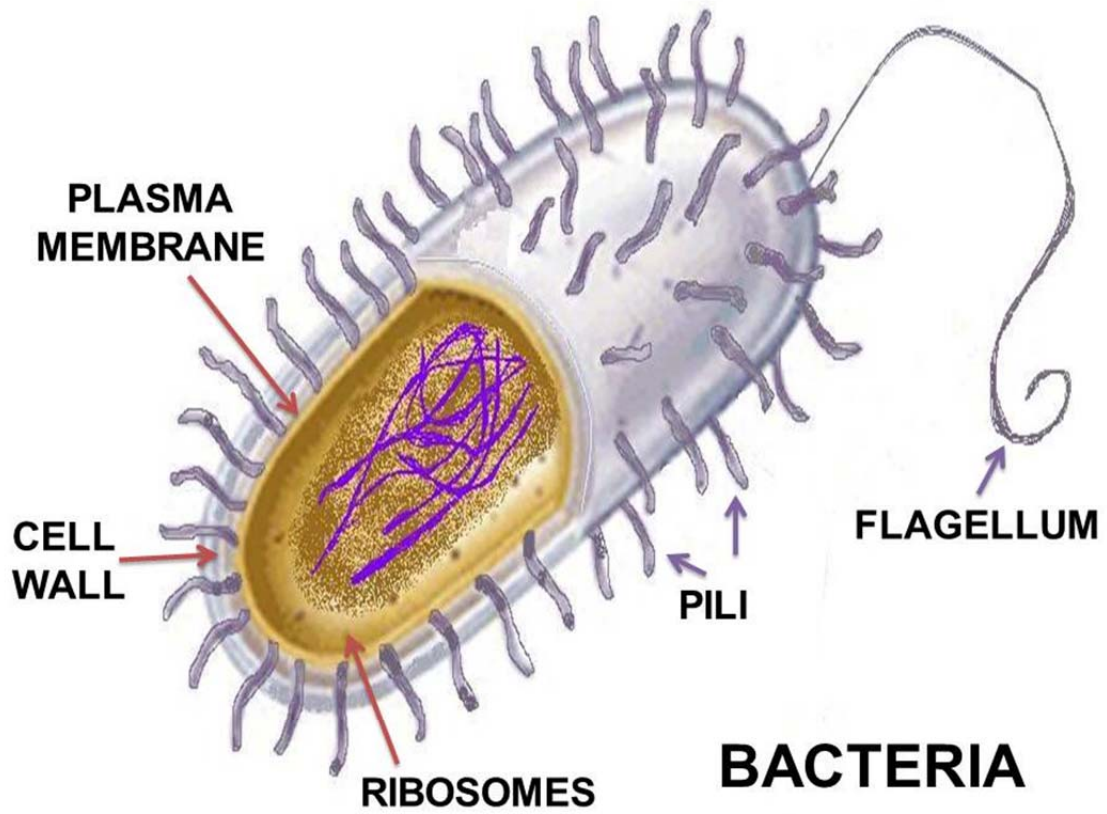

Peritrichous Bacteria

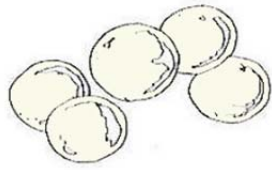

**COCCI
(SPHERICAL)**

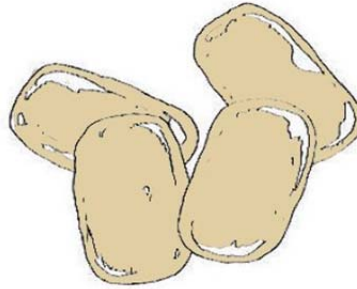

**BACILLI
(ROD-SHAPED)**

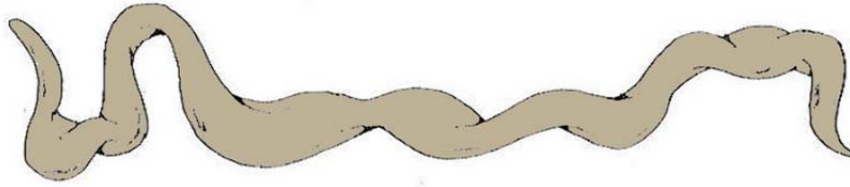

**SPIRILLI
(SPIRAL)**

BACTERIA TYPES

Microbiologists broadly classify bacteria according to their shape: spherical, rod-shaped, and spiral-shaped. Pleomorphic bacteria can assume a variety of shapes. Bacteria may be further classified according to whether they require oxygen (aerobic or anaerobic) and how they react to a test with Gram's stain. Bacteria in which alcohol washes away Gram's stain are called gram-negative, while bacteria in which alcohol causes the bacteria's walls to absorb the stain are called gram-positive.



**COLORLESS FILAMENTOUS
SULFUR BACTERIA**

Shigella dysenteriae

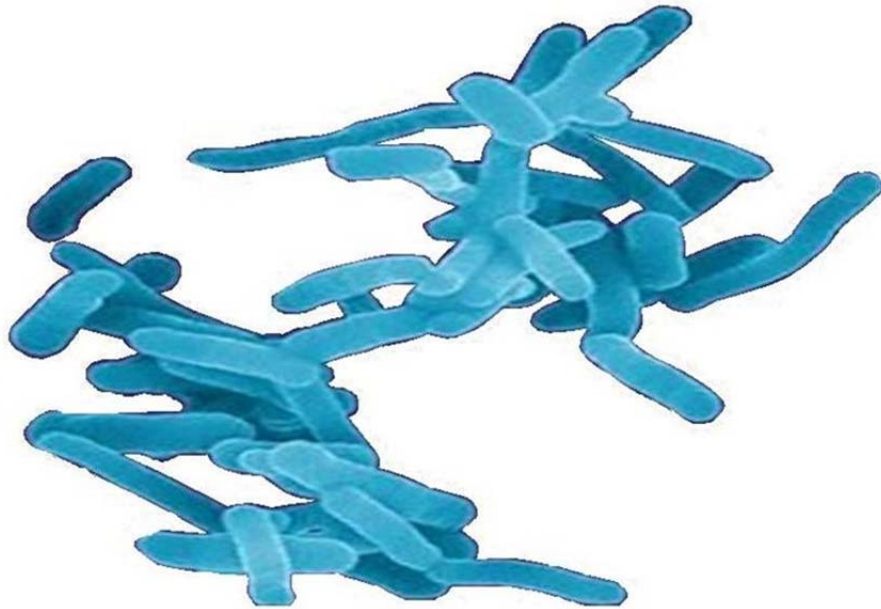

SHIGELLA DYSENTERIAE

Shigella dysenteriae is a species of the rod-shaped bacterial genus *Shigella*. *Shigella* can cause shigellosis (bacillary dysentery). Shigellae are Gram-negative, non-spore-forming, facultatively anaerobic, non-motile bacteria.

S. dysenteriae, spread by contaminated water and food, causes the most severe dysentery because of its potent and deadly Shiga toxin, but other species may also be dysentery agents. *Shigella* infection is typically via ingestion (fecal–oral contamination); depending on age and condition of the host as few as ten bacterial cells can be enough to cause an infection. *Shigella* causes dysentery that result in the destruction of the epithelial cells of the intestinal mucosa in the cecum and rectum. Some strains produce enterotoxin and Shiga toxin, similar to the verotoxin of *E. coli* O157:H7. Both Shiga toxin and verotoxin are associated with causing hemolytic uremic syndrome.

Shigella invades the host through epithelial cells of the large intestine. Using a Type III secretion system acting as a biological syringe, the bacterium injects IpaD protein into cell, triggering bacterial invasion and the subsequent lysis of vacuolar membranes using IpaB and IpaC proteins. It utilizes a mechanism for its motility by which its IcsA protein triggers actin polymerization in the host cell (via N-WASP recruitment of Arp2/3 complexes) in a "rocket" propulsion fashion for cell-to-cell spread.

The most common symptoms are diarrhea, fever, nausea, vomiting, stomach cramps, and straining to have a bowel movement. The stool may contain blood, mucus, or pus (e.g. dysentery). In rare cases, young children may have seizures. Symptoms can take as long as a week to show up, but most often begin two to four days after ingestion. Symptoms usually last for several days, but can last for weeks. *Shigella* is implicated as one of the pathogenic causes of reactive arthritis worldwide.



Coccus



Bacillus



Spirillum

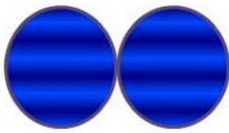

Diplo-

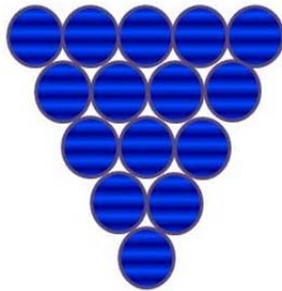

Staphylo-



Strepto-

Bacteria Types

Type	Characteristics
Acetic acid	Rod-shaped, gram-negative, aerobic; highly tolerant of acidic conditions; generate organic acids
Actinomycete	Rod-shaped or filamentous, gram-positive, aerobic; common in soils; essential to growth of many plants; source of much of original antibiotic production in pharmaceutical industry
Cocoid	Spherical, sometimes in clusters or strings, gram-positive, aerobic and anaerobic; resistant to drying and high-salt conditions; <i>Staphylococcus</i> species common on human skin, certain strains associated with toxic shock syndrome
Coryneform	Rod-shaped, form club or V shapes, gram-positive, aerobic; found in wide variety of habitats, particularly soils; highly resistant to drying; include <i>Arthrobacter</i> , among most common forms of life on earth
Endospore-forming	Usually rod-shaped, can be gram-positive or gram-negative; have highly adaptable, heat-resistant spores that can go dormant for long periods, possibly thousands of years; include <i>Clostridium</i> (anaerobic) and <i>Bacillus</i> (aerobic)
Enteric	Rod-shaped, gram-negative, aerobic but can live in certain anaerobic conditions; produce nitrite from nitrate, acids from glucose; include <i>Escherichia coli</i> , <i>Salmonella</i> (over 1000 types), and <i>Shigella</i>
Gliding	Rod-shaped, gram-negative, mostly aerobic; glide on secreted slimy substances; form colonies, frequently with complex fruiting structures
Lactic acid	Gram-positive, anaerobic; produce lactic acid through fermentation; include <i>Lactobacillus</i> , essential in dairy product formation, and <i>Streptococcus</i> , common in humans
Mycobacterium	Pleomorphic, spherical or rod-shaped, frequently branching, no gram stain, aerobic; commonly form yellow pigments; include <i>Mycobacterium tuberculosis</i> , cause of tuberculosis
Mycoplasma	Spherical, commonly forming branching chains, no gram stain, aerobic but can live in certain anaerobic conditions; without cell walls yet structurally resistant to lysis; among smallest of bacteria; named for superficial resemblance to fungal hyphae (<i>myco-</i> means 'fungus')
Nitrogen-fixing	Rod-shaped, gram-negative, aerobic; convert atmospheric nitrogen gas to ammonium in soil; include <i>Azotobacter</i> , a common genus
Propionic acid	Rod-shaped, pleomorphic, gram-positive, anaerobic; ferment lactic acid; fermentation produces holes in Swiss cheese from the production of carbon dioxide
Pseudomonad	Rod-shaped (straight or curved) with polar flagella, gram-negative, aerobic; can use up to 100 different compounds for carbon and energy
Rickettsia	Spherical or rod-shaped, gram-negative, aerobic; cause Rocky Mountain spotted fever and typhus; closely related to <i>Agrobacterium</i> , a common gall-causing plant bacterium
Sheathed	Filamentous, gram-negative, aerobic; 'swarmer' (colonizing) cells form and break out of a sheath; sometimes coated with metals from environment

Spirillum	Spiral-shaped, gram-negative, aerobic; include <i>Bdellovibrio</i> , predatory on other bacteria
Spirochete	Spiral-shaped, gram-negative, mostly anaerobic; common in moist environments, from mammalian gums to coastal mudflats; complex internal structures convey rapid movement; include <i>Treponemapallidum</i> , cause of syphilis
Sulfate- and Sulfur-reducing	Commonly rod-shaped, mostly gram-negative, anaerobic; include <i>Desulfovibrio</i> , ecologically important in marshes
Sulfur- and iron-oxidizing	Commonly rod-shaped, frequently with polar flagella, gram-negative, mostly anaerobic; most live in neutral (nonacidic) environment
Vibrio	Rod- or comma-shaped, gram-negative, aerobic; commonly with a single flagellum; include <i>Vibrio cholerae</i> , cause of cholera, and luminescent forms symbiotic with deep-water fishes and squids

Gram⁺



Lactobacillus acidophilus



Streptococcus thermophilus

Gram⁻

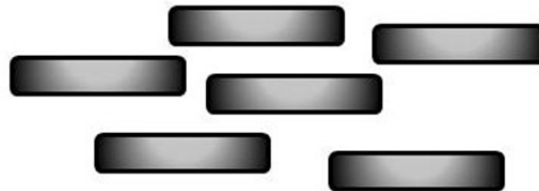

Escherichia coli

Salmonella

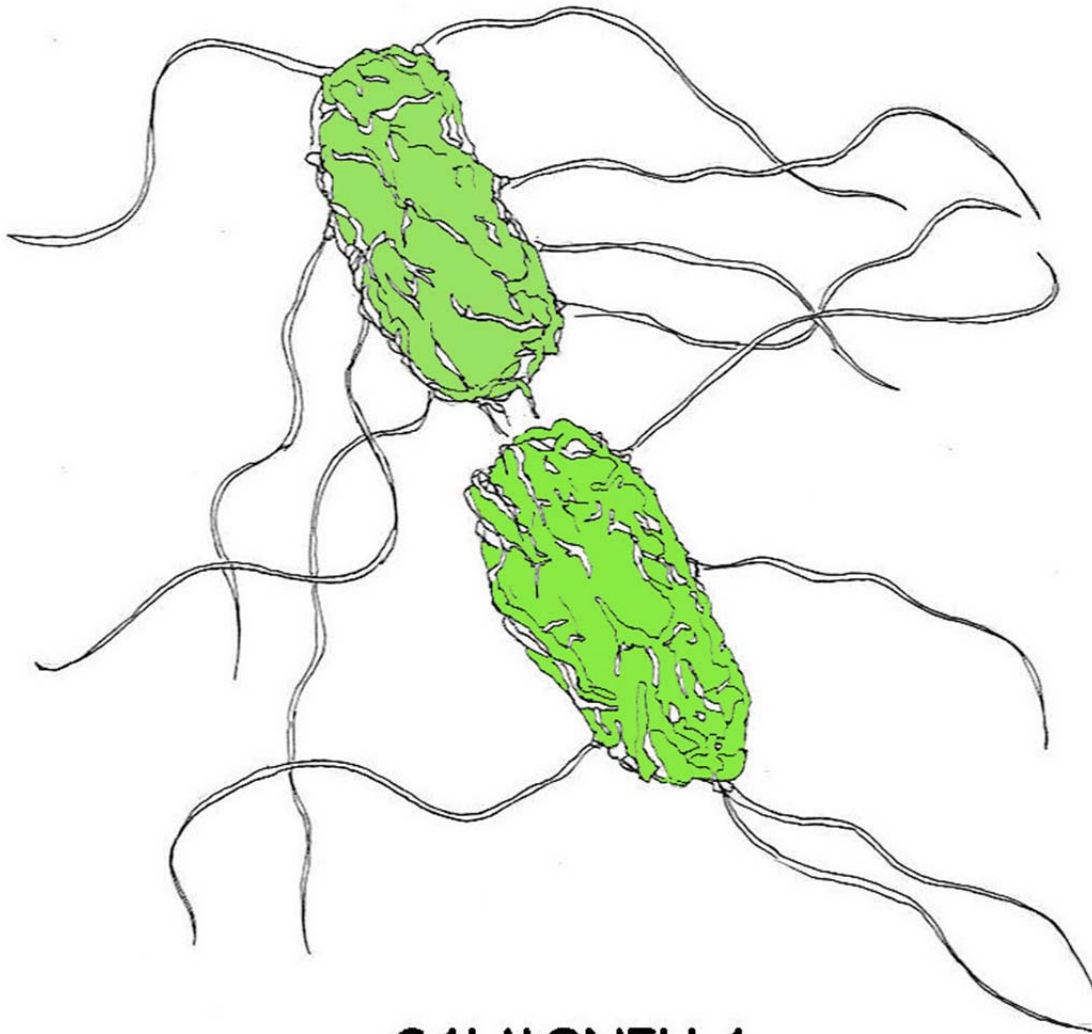

SALMONELLA

Salmonella is a Gram-negative bacterium. It is found in many turtles and other reptiles. In clinical laboratories, it is usually isolated on MacConkey agar, XLD agar, XLT agar, DCA agar, or Önoz agar. Because they cause intestinal infections and are greatly outnumbered by the bacteria normally found in the healthy bowel, primary isolation requires the use of a selective medium, so use of a relatively non-selective medium such as CLED agar is not often practiced. Numbers of salmonella may be so low in clinical samples that stools are routinely also subjected to "enrichment culture", where a small volume of stool is incubated in a selective broth medium, such as selenite broth or Rappaport Vassiliadis soya peptone broth, overnight. These media are inhibitory to the growth of the microbes normally found in the healthy human bowel, while allowing salmonellae to become enriched in numbers. Salmonellae may then be recovered by inoculating the enrichment broth on one or more of the primary selective media. On blood agar, they form moist colonies about 2 to 3 mm in diameter.

When the cells are grown for a prolonged time at a range of 25—28°C, some strains produce a biofilm, which is a matrix of complex carbohydrates, cellulose and proteins. The ability to produce biofilm (a.k.a. "rugose", "lacy", or "wrinkled") can be an indicator of dimorphism, which is the ability of a single genome to produce multiple phenotypes in response to environmental conditions. Salmonellae usually do not ferment lactose; most of them produce hydrogen sulfide which, in media containing ferric ammonium citrate, reacts to form a black spot in the centre of the creamy colonies.

Classification

Salmonella taxonomy is complicated. As of December 7, 2005, there are two species within the genus: *S. bongori* (previously subspecies V) and *S. enterica* (formerly called *S. choleraesuis*), which is divided into six subspecies:

- * I—enterica
- * II—salamae
- * IIIa—arizonae
- * IIIb—diarizonae
- * IV—houtenae
- * V—obsolete (now designated *S. bongori*)
- * VI—indica

There are also numerous (over 2500) serovars within both species, which are found in a disparate variety of environments and which are associated with many different diseases. The vast majority of human isolates (>99.5%) are subspecies *S. enterica*. For the sake of simplicity, the CDC recommends that *Salmonella* species be referred to only by their genus and serovar, e.g.

Salmonella Typhi instead of the more technically correct designation, *Salmonella enterica* subspecies enterica serovar Typhi.

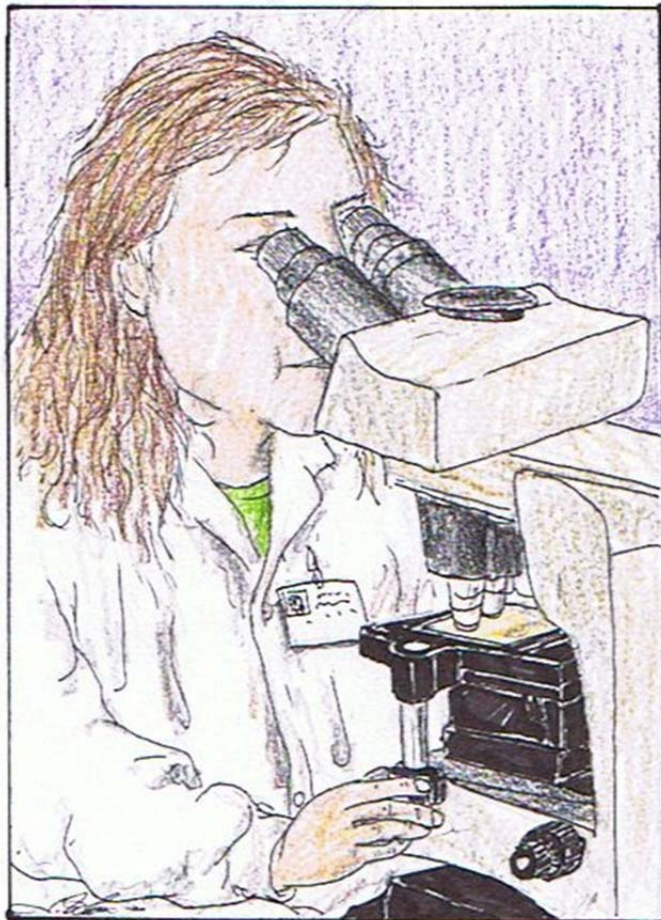

Escherichia Coli Section

Fecal Coliform Bacteria

Fecal coliform bacteria are microscopic organisms that live in the intestines of warm-blooded animals. They also live in the waste material, or feces, excreted from the intestinal tract. When fecal coliform bacteria are present in high numbers in a water sample, it means that the water has received fecal matter from one source or another. Although not necessarily agents of disease, fecal coliform bacteria may indicate the presence of disease-carrying organisms, which live in the same environment as the fecal coliform bacteria.

Reasons for Natural Variation

Unlike the other conventional water quality parameters, fecal coliform bacteria are living organisms. They do not simply mix with the water and float straight downstream. Instead they multiply quickly when conditions are favorable for growth, or die in large numbers when conditions are not. Because bacterial concentrations are dependent on specific conditions for growth, and these conditions change quickly, fecal coliform bacteria counts are not easy to predict. For example, although winter rains may wash more fecal matter from urban areas into a stream, cool water temperatures may cause a major die-off. Exposure to sunlight (with its ultraviolet disinfection properties) may have the same effect, even in the warmer water of summertime.

Expected Impact of Pollution

The primary sources of fecal coliform bacteria to fresh water are wastewater treatment plant discharges, failing septic systems, and animal waste. Bacteria levels do not necessarily decrease as a watershed develops from rural to urban. Instead, urbanization usually generates new sources of bacteria. Farm animal manure and septic systems are replaced by domestic pets and leaking sanitary sewers. In fact, stormwater runoff in urbanized areas has been found to be surprisingly high in fecal coliform bacteria concentrations.

The presence of old, disintegrating storm and sanitary sewers, misplaced sewer pipes, and good breeding conditions are common explanations for the high levels measured.

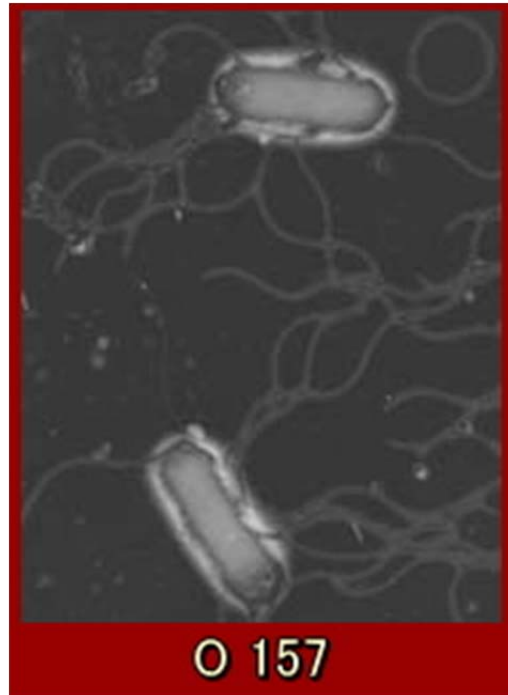

Coliform Standards (in colonies/100ml)

Drinking water.....	1FC
Total body contact (swimming).....	200FC
Partial body contact (boating).....	1000FC
Threatened sewage effluent	not to exceed 200 FC

*Total coliform (TC) includes bacteria from cold-blooded animals and various soil organisms. According to recent literature, total coliform counts are normally about 10 times higher than fecal coliform (FC) counts.

Indicator Connection Varies

General coliforms, E. Coli, and Enterococcus bacteria are the "indicator" organisms generally measured to assess microbiological quality of water. However, these aren't generally what get people sick. Other bacteria, viruses, and parasites are what we are actually worried about.

Because it is so much more expensive and tedious to do so, actual pathogens are virtually never tested for. Over the course of a professional lifetime pouring over indicator tests, in a context where all standards are based on indicators, water workers tend to forget that the indicators are not the things we actually care about.

What are these indicators? More information in the Laboratory section.

- **General coliforms** indicate that the water has come in contact with plant or animal life. General coliforms are universally present, including in pristine spring water. They are of little concern at low levels, except to indicate the effectiveness of disinfection. Chlorinated water and water from perfectly sealed tube wells is the only water I've tested which had zero general coliforms. At very high levels they indicate there is what amounts to a lot of compost in the water, which could easily include pathogens (Ten thousand general coliform bacteria will get you a beach closure, compared to two or four hundred fecal coliforms, or fifty enterococcus).
- **Fecal coliforms**, particularly E. coli, indicate that there are mammal or bird feces in the water.
- **Enterococcus bacteria** also indicate that there are feces from warm blooded animals in the water. Enterococcus are a type of fecal streptococci. They are another valuable indicator for determining the amount of fecal contamination of water.

According to studies conducted by the EPA, enterococci have a greater correlation with swimming-associated gastrointestinal illness in both marine and fresh waters than other bacterial indicator organisms, and are less likely to "die off" in saltwater.

The more closely related the animal, the more likely pathogens excreted with their feces can infect us. Human feces are the biggest concern, because anything which infects one human could infect another. There isn't currently a quantitative method for measuring specifically human fecal bacteria (expensive genetic studies can give a presence/absence result). Ingesting a human stranger's feces via contaminated water supply is a classic means for infections to spread rapidly. The more pathogens an individual carries, the more hazardous their feces. Ingesting feces from someone who is not carrying any pathogens may gross you out, but it can't infect you. Infection rates are around 5% in the US, and approach 100% in areas with poor hygiene and contaminated water supplies. Keep in the back of your mind that **the ratio of indicators to actual pathogens is not fixed**. It will always be different, sometimes very different. Whenever you are trying to form a mental map of reality based on water tests, you should include in the application of your water intuition an adjustment factor for your best guess of the ratio between indicators and actual pathogens.

Membrane Filter Total Coliform Technique

The membrane filter total Coliform technique is used at Medina County for drinking water quality testing. The following is a summary of this test. A sampling procedure sheet is given to all sample takers by Medina County.

The samples are taken in sterile 100 mL containers. These containers, when used for chlorinated water samples, have a sodium thiosulfate pill or solution to dechlorinate the sample.

The sample is placed in cold storage after proper sample taking procedures are followed. (See sample procedures below)

The samples are taken to the laboratory with a chain of custody to assure no tampering of samples can occur.

These samples are logged in at the laboratory.

No longer than 30 hours can lapse between the time of sampling and time of test incubation. (8 hours for heterotrophic, nonpotable 6 hours, others not longer than 24 hours)

All equipment is sterilized by oven and autoclave.

Glassware in oven at $170^{\circ}\text{C} \pm 10^{\circ}\text{C}$ with foil (or other suitable wrap) loosely fitting and secured immediately after sterilization.

Filtration units in autoclave at 121°C for 30 minutes.

Use sterile petri dishes, grid, and pads bought from a reliable company – certified, quality assured - test for satisfactory known positive amounts.

Incubators – $35^{\circ}\text{C} \pm .5^{\circ}\text{C}$ (60% relative humidity)

M-endo medium is prepared and heated to near boiling removed from heat cooled to 45°C pH adjusted to $7.2 \pm .2$ and immediately dispensed 8ml to plates. Keep refrigerated and discard after 2 weeks.

Lab #	Date	Time	Collector	Analyst	Sample Location	Total Coliform	Total Coliform	E. Coli	Coliform	Test Method	Checked
1161	8-8	9:25	578	11/14	1400	Blank					
1162		9:20			1400	Substation					
1163		9:41			505	Substation					
1164		10:25			580	Lumpert					
1165		10:20			720	Lumpert					
1166		10:35			770	Manly					
1167		10:41			5321	Center					
1168		8:30			5327	Center					
1169		9:30			Butkin	Pool					
					St Paul	Church					
					Final	Blank					
					Filter						



Plates can be stored in a dated box with expiration date and discarded if not used. No denatured alcohol should be used. Everclear or 95% proof alcohol or absolute methyl may be used for sterilizing forceps by flame.

Procedure:

Counters are alcohol wiped.

Bench sheets are filled out.

Samples are removed from refrigeration.

Sterile wrapped utensils are placed on counters.

Filtration units are placed onto sterile membrane filters by aseptic technique using sterile forceps.

Sterile petri dishes are labeled.

The samples closures are clipped.

The sample is shaken 25 times 1 foot in length within 7 seconds.

100 mL is filtered and rinsed with sterile distilled water 3 times.

The membrane filter is aseptically removed from filter holder.

A sterile padded petri dish is used and the membrane filter is rolled onto the pad making sure no air bubbles form.

The sterile labeled lid is placed on the petri dish.

2 blanks and a known is run with each series of samples.

The samples are placed in the $35^{\circ}\text{C} \pm .5^{\circ}\text{C}$ incubator stacked no higher than 3 for 22 – 24 hours (Humidity can be maintained by saturated paper towels placed under containers holding petri dishes.)

After 22- 24 hours view the petri dishes under a 10 –15 power magnification with cool white fluorescent light.

Count all colonies that appear pink to dark red with a metallic surface sheen – the sheen may vary in size from a pin head to complete coverage.

Report as Total Coliform per 100 mL.

If no colonies are present report as <1 coliform/100mL.

Anything greater than 1 is over the limit for drinking water for 2 samples taken 24 hours apart. Further investigation may be necessary – follow Standard Methods accordingly.



Photograph and Credits to Mary McPherson
Aran™ Aqua Analytical Laboratory Director.

Escherichia coli EPEC

Two types of pathogenic *Escherichia coli*, enteropathogenic *E. coli* (EPEC) and enterohemorrhagic *E. coli* (EHEC), cause diarrheal disease by disrupting the intestinal environment through the intimate attachment of the bacteria to the intestinal epithelium.

E. coli O157:H7

E. coli O157:H7 (bacterium) found in human feces. Symptoms vary with type caused gastroenteritis.

Escherichia coli O157:H7 is an emerging cause of foodborne illness. An estimated 73,000 cases of infection and 61 deaths occur in the United States each year. Infection often leads to bloody diarrhea, and occasionally to kidney failure. Most illnesses have been associated with eating undercooked, contaminated ground beef. Person-to-person contact in families and child care centers is also an important mode of transmission. Infection can also occur after drinking raw milk and after swimming in or drinking sewage-contaminated water.

Consumers can prevent *E. coli* O157:H7 infection by thoroughly cooking ground beef, avoiding unpasteurized milk, and washing hands carefully. Because the organism lives in the intestines of healthy cattle, preventive measures on cattle farms and during meat processing are being investigated.

What is *Escherichia coli* O157:H7?

E. coli O157:H7 is one of hundreds of strains of the bacterium *Escherichia coli*. Although most strains are harmless and live in the intestines of healthy humans and animals, this strain produces a powerful toxin and can cause severe illness.

E. coli O157:H7 was first recognized as a cause of illness in 1982 during an outbreak of severe bloody diarrhea; the outbreak was traced to contaminated hamburgers. Since then, most infections have come from eating undercooked ground beef.

The combination of letters and numbers in the name of the bacterium refers to the specific markers found on its surface and distinguishes it from other types of *E. coli*.

Currently, there are four recognized classes of enterovirulent *E. coli* (collectively referred to as the EEC group) that cause gastroenteritis in humans. Among these is the enterohemorrhagic (EHEC) strain designated *E. coli* O157:H7. *E. coli* is a normal inhabitant of the intestines of all animals, including humans. When aerobic culture methods are used, *E. coli* is the dominant species found in feces.

Normally *E. coli* serves a useful function in the body by suppressing the growth of harmful bacterial species and by synthesizing appreciable amounts of vitamins. A minority of *E. coli* strains are capable of causing human illness by several different mechanisms. *E. coli* serotype O157:H7 is a rare variety of *E. coli* that produces large quantities of one or more related, potent toxins that cause severe damage to the lining of the intestine. These toxins [verotoxin (VT), shiga-like toxin] are closely related or identical to the toxin produced by *Shigella dysenteriae*.

How does *E. coli* or other fecal coliforms get in the water?

E. coli comes from human and animal wastes. During rainfalls, snow melts, or other types of precipitation, *E. coli* may be washed into creeks, rivers, streams, lakes, or groundwater. When these waters are used as sources of drinking water and the water is not treated or inadequately treated, *E. coli* may end up in drinking water.

How is water treated to protect me from *E. coli*?

The water can be treated using chlorine, ultra-violet light, or ozone, all of which act to kill or inactivate *E. coli*. Systems using surface water sources are required to disinfect to ensure that all bacterial contamination such as *E. coli* is inactivated. Systems using ground water sources are not required to disinfect, although many of them do.

How does the U.S. Environmental Protection Agency regulate *E. coli*?

According to EPA regulations, a system that operates at least 60 days per year, and serves 25 people or more or has 15 or more service connections, is regulated as a public water system under the Safe Drinking Water Act. If a system is not a public water system as defined by EPA regulations, it is not regulated under the Safe Drinking Water Act, although it may be regulated by state or local authorities.

Under the Safe Drinking Water Act, the EPA requires public water systems to monitor for coliform bacteria. Systems analyze first for total coliform, because this test is faster to produce results. Any time that a sample is positive for total coliform, the same sample must be analyzed for either fecal coliform or *E. coli*. Both are indicators of contamination with animal waste or human sewage.

The largest public water systems (serving millions of people) must take at least 480 samples per month. Smaller systems must take at least five samples a month unless the state has conducted a sanitary survey – a survey in which a state inspector examines system components and ensures they will protect public health – at the system within the last five years.

Systems serving 25 to 1,000 people typically take one sample per month. Some states reduce this frequency to quarterly for ground water systems if a recent sanitary survey shows that the system is free of sanitary defects. Some types of systems can qualify for annual monitoring. Systems using surface water, rather than ground water, are required to take extra steps to protect against bacterial contamination because surface water sources are more vulnerable to such contamination. At a minimum, all systems using surface waters must disinfect. Disinfection will kill *E. coli* O157:H7.

What can I do to protect myself from *E. coli* O157:H7 in drinking water?

Approximately 89 percent of Americans are receiving water from community water systems that meet all health-based standards. Your public water system is required to notify you if, for any reason, your drinking water is not safe. If you wish to take extra precautions, you can boil your water for one minute at a rolling boil, longer at higher altitudes. To find out more information about your water, see the Consumer Confidence Report from your local water supplier or contact your local water supplier directly. You can also obtain information about your local water system on the EPA's website at www.epa.gov/safewater/dwinfo.htm.

Positive Tests

If you draw water from a private well, you can contact your state health department to obtain information on how to have your well tested for total coliforms, and *E. coli* contamination. If your well tests positive for *E. coli*, there are several steps that you should take: (1) begin boiling all water intended for consumption, (2) disinfect the well according to procedures recommended by your local health department, and (3) monitor your water quality to make certain that the problem does not recur. If the contamination is a recurring problem, you should investigate the feasibility of drilling a new well or install a point-of-entry disinfection unit, which can use chlorine, ultraviolet light, or ozone.



How is *E. coli* O157:H7 spread?

The organism can be found on a small number of cattle farms and can live in the intestines of healthy cattle. Meat can become contaminated during slaughter, and organisms can be thoroughly mixed into beef when it is ground. Bacteria present on a cow's udders or on equipment may get into raw milk. Eating meat, especially ground beef that has not been cooked sufficiently to kill *E. coli* O157:H7 can cause infection. Contaminated meat looks and smells normal. Although the number of organisms required to cause disease is not known, it is suspected to be very small.

Among other known sources of infection are consumption of sprouts, lettuce, salami, unpasteurized milk and juice, and swimming in or drinking sewage-contaminated water. Bacteria in diarrheal stools of infected persons can be passed from one person to another if hygiene or hand washing habits are inadequate. This is particularly likely among toddlers who are not toilet trained. Family members and playmates of these children are at high risk of becoming infected. Young children typically shed the organism in their feces for a week or two after their illness resolves. Older children rarely carry the organism without symptoms.

What illness does *E. coli* O157:H7 cause?

E. coli O157:H7 infection often causes severe bloody diarrhea and abdominal cramps; sometimes the infection causes non-bloody diarrhea or no symptoms. Usually little or no fever is present, and the illness resolves in 5 to 10 days. Hemorrhagic colitis is the name of the acute disease caused by *E. coli* O157:H7.

In some persons, particularly children under 5 years of age and the elderly, the infection can also cause a complication called hemolytic uremic syndrome, in which the red blood cells are destroyed and the kidneys fail. About 2%-7% of infections lead to this complication. In the United States, hemolytic uremic syndrome is the principal cause of acute kidney failure in children, and most cases of hemolytic uremic syndrome are caused by *E. coli* O157:H7.

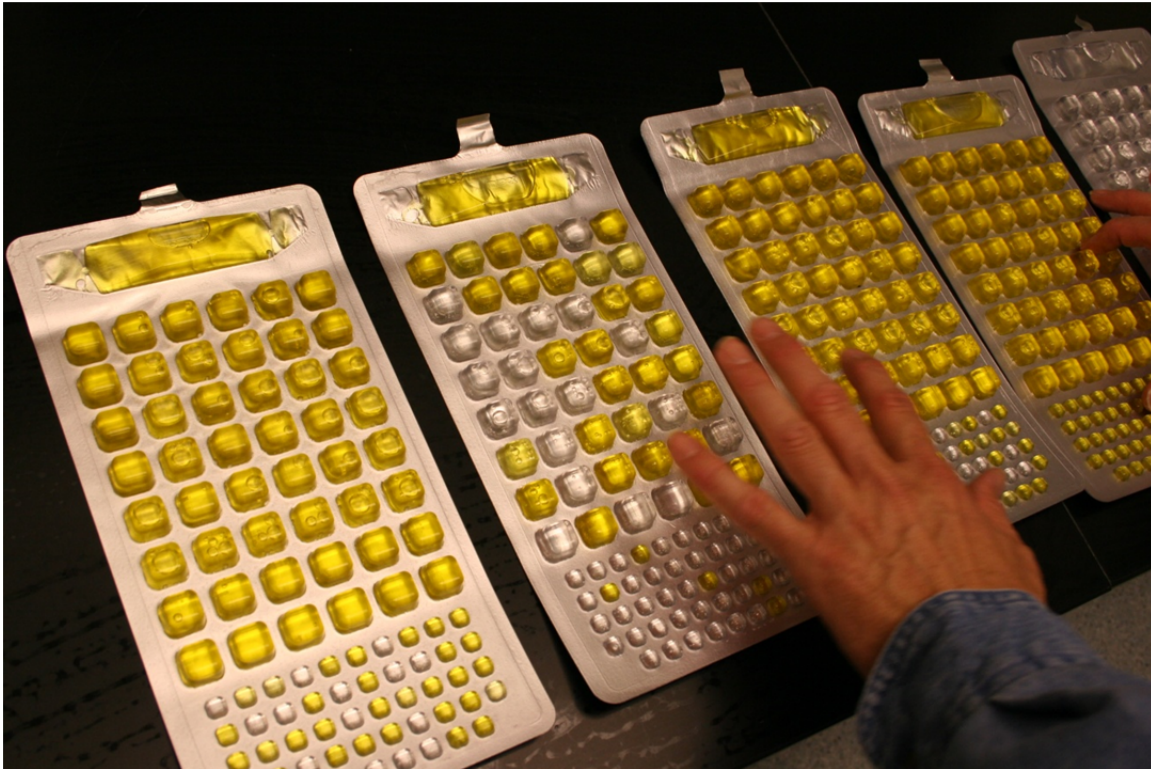

How is *E. coli* O157:H7 infection diagnosed?

Infection with *E. coli* O157:H7 is diagnosed by detecting the bacterium in the stool. Most laboratories that culture stool do not test for *E. coli* O157:H7, so it is important to request that the stool specimen be tested on sorbitol-MacConkey (SMAC) agar for this organism. All persons who suddenly have diarrhea with blood should get their stool tested for *E. coli* O157:H7.

How is the illness treated?

Most persons recover without antibiotics or other specific treatment in 5-10 days. There is no evidence that antibiotics improve the course of disease, and it is thought that treatment with some antibiotics may precipitate kidney complications. Antidiarrheal agents, such as loperamide (Imodium), should also be avoided. Hemolytic uremic syndrome is a life-threatening condition usually treated in an intensive care unit. Blood transfusions and kidney dialysis are often required. With intensive care, the death rate for hemolytic uremic syndrome is 3%-5%.

Legionnaires' Disease Legionella Section

Introduction Genus: *Legionella* Species: *pneumophila*

The first discovery of bacteria from genus *Legionella* came in 1976 when an outbreak of pneumonia at an American Legion convention led to 29 deaths. The causative agent, what would come to be known as *Legionella pneumophila*, was isolated and given its own genus. The organisms classified in this genus are Gram-negative bacteria that are considered intracellular parasites. The disease has two distinct forms:

- Legionnaires' disease, the more severe form of infection which includes pneumonia, and
- Pontiac fever, a milder illness.

What have been the water sources for Legionnaires' disease?

The major source is water distribution systems of large buildings, including hotels and hospitals. Cooling towers have long been thought to be a major source for *Legionella*, but new data suggest that this is an overemphasized mode of transmission. Other sources include mist machines, humidifiers, whirlpool spas, and hot springs. Air conditioners are not a source for Legionnaires' disease. They were suspected to be the source in the original American Legion outbreak in a Philadelphia hotel, but new data now suggests that the water in the hotel was the actual culprit.

Legionnaire's disease is caused most commonly by the inhalation of small droplets of water or fine aerosol containing *Legionella* bacteria. *Legionella* bacteria are naturally found in environmental water sources such as rivers, lakes and ponds and may colonize man-made water systems that include air conditioning systems, humidifiers, cooling tower waters, hot water systems, spas and pools.

How do people contract *Legionella*?

The most popular theory is that the organism is aerosolized in water and people inhale the droplets containing *Legionella*. However, new evidence suggests that another way of contracting *Legionella* is more common. "Aspiration" is the most common way that bacteria enter into the lungs to cause pneumonia. Aspiration means choking such that secretions in the mouth get past the choking reflexes and instead of going into the esophagus and stomach, mistakenly, enter the lung. The protective mechanisms to prevent aspiration is defective in patients who smoke or have lung disease. Aspiration now appears to be the most common mode of transmission.

Legionella may multiply to high numbers in cooling towers, evaporative condensers, air washers, humidifiers, hot water heaters, spas, fountains, and plumbing fixtures. Within one month, *Legionella* can multiply, in warm water-containing systems, from less than 10 per milliliter to over 1,000 per milliliter of water. Once high numbers of *Legionella* have been found, a relatively simple procedure for disinfecting water systems with chlorine and detergent is available. This procedure is not part of a routine maintenance program because equipment may become corroded.

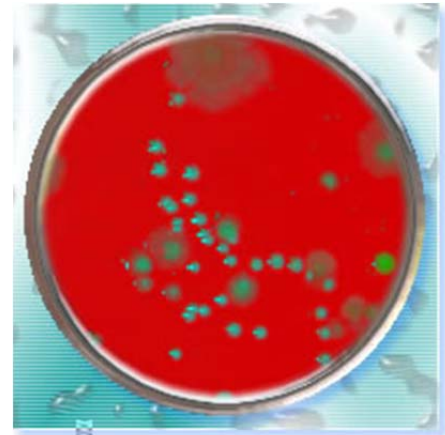

Property owners have been sued for the spread of Legionella, resulting in expensive settlements. Regular monitoring with a battery of DFA monoclonal antibodies for several serogroups and species of Legionella morphologically intact bacteria provides a means for exercising 'reasonable care' to deter potential litigation.

Currently, there are no United States government regulations concerning permissible numbers of legionella in water systems and there are no federal or state certification programs for laboratories that perform legionella testing of environmental samples.

Epifluorescence Microscopy DFA Method

The epifluorescence microscopy DFA method that most labs use was published in the British Journal, Water Research 19:839-848, 1985 "Disinfection of circulating water systems by ultraviolet light and halogenation", R. Gilpin, et al. so we can count viable-but-nonculturable (VBNC) legionella.

Most labs will provide a quantitative epifluorescence microscopic analysis of your cooling tower and potable water samples for 14 serogroups of Legionella pneumophila and 15 other Legionella species (listed below).

<i>Legionella anisa</i>	<i>Legionella bozemanii</i> sg 1 & 2
<i>Legionella dumoffi</i>	<i>Legionella feeleii</i> sg 1 & 2
<i>Legionella gormanii</i>	<i>Legionella hackeliae</i> sg 1 & 2
<i>Legionella jordanis</i>	<i>Legionella longbeachae</i> sg 1& 2
<i>Legionella maceachernii</i>	<i>Legionella micdadei</i>
<i>Legionella oakridgensis</i>	<i>Legionella parisiensis</i>
<i>Legionella pneumophila</i> sg 1-14	<i>Legionella sainthelensi</i>
<i>Legionella santacrucis</i>	<i>Legionella wadsworthii</i>

Heterotrophic bacterial CFU are often inversely proportional to numbers of Legionella in cooling tower samples, in our experience. Routine biocide treatments will not eradicate Legionella bacteria in the environment, only in laboratory studies.

Culture methods are good during outbreaks for bio-typing; but culture methods lack sensitivity for routine, quantitative monitoring. Many factors will inhibit growth or identification of legionella on BCYE with or without antimicrobial agents, heat or acid treatment.

Culture methods will not identify non-culturable legionella that can still cause outbreaks (non-culturable, viable legionella have been reported in several peer-reviewed journals). Only DFA tests performed by trained laboratory personnel can identify these legionella. Direct fluorescent antibody (DFA) tests using a battery of monoclonal antibodies provide more useful routine monitoring information than culture methods. Legionella species of bacteria cause Legionnaire's disease. They are gram negative (but stain poorly), strictly aerobic rods.

The U.S. Environmental Protection Agency and the U.S. Occupational Safety and Health Administration recommend routine maintenance of water-containing equipment. Most State health departments recommend monthly testing for Legionella as part of a routine maintenance program.

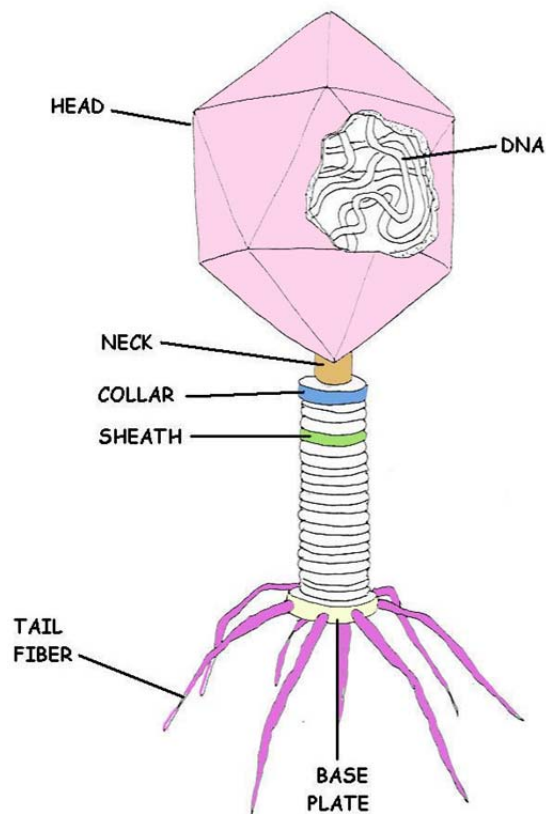

BACTERIOPHAGE

Bacteriophage

A bacteriophage (from 'bacteria' and Greek phagein, 'to eat') is any one of a number of viruses that infect bacteria. The term is commonly used in its shortened form, phage.

Typically, bacteriophages consist of an outer protein hull enclosing genetic material. The genetic material can be ssRNA (single stranded RNA), dsRNA, ssDNA, or dsDNA between 5 and 500 kilo base pairs long with either circular or linear arrangement. Bacteriophages are much smaller than the bacteria they destroy - usually between 20 and 200 nm in size.

Phages are estimated to be the most widely distributed and diverse entities in the biosphere. Phages are ubiquitous and can be found in all reservoirs populated by bacterial hosts, such as soil or the intestine of animals. One of the densest natural sources for phages and other viruses is sea water, where up to 9×10^8 virions per milliliter have been found in microbial mats at the surface, and up to 70% of marine bacteria may be infected by phages.

VIRUS CAPSID (BACTERIOPHAGES)

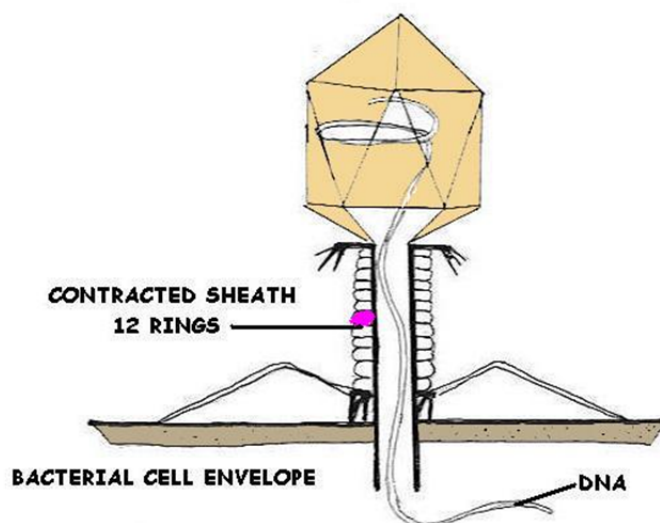
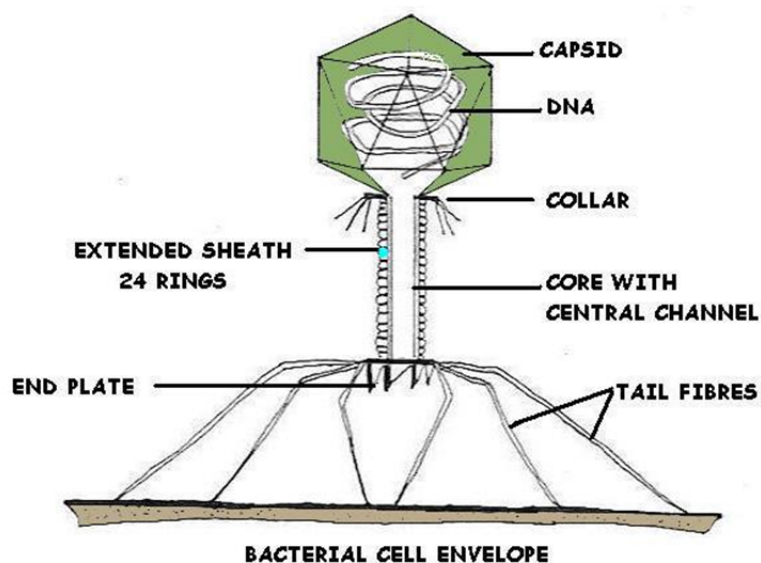

Release of Virions

Phages may be released via cell lysis or by host cell secretion. In the case of the T4 phage, in just over twenty minutes after injection upwards of three hundred phages will be released via lysis within a certain timescale. This is achieved by an enzyme called endolysin which attacks and breaks down the peptidoglycan. In contrast, "lysogenic" phages do not kill the host but rather become long-term parasites and make the host cell continually secrete more new virus particles. The new virions bud off the plasma membrane, taking a portion of it with them to become enveloped viruses possessing a viral envelope. All released virions are capable of infecting a new bacterium.

Viruses

Viruses are acellular microorganisms. They are made up of only genetic material and a protein coat. Viruses depend on the energy and metabolic machinery of the host cell to reproduce. A virus is an infectious agent found in virtually all life forms, including humans, animals, plants, fungi, and bacteria. Viruses consist of genetic material—either deoxyribonucleic acid (DNA) or ribonucleic acid (RNA)—surrounded by a protective coating of protein, called a capsid, with or without an outer lipid envelope. Viruses are between 20 and 100 times smaller than bacteria and hence are too small to be seen by light microscopy.

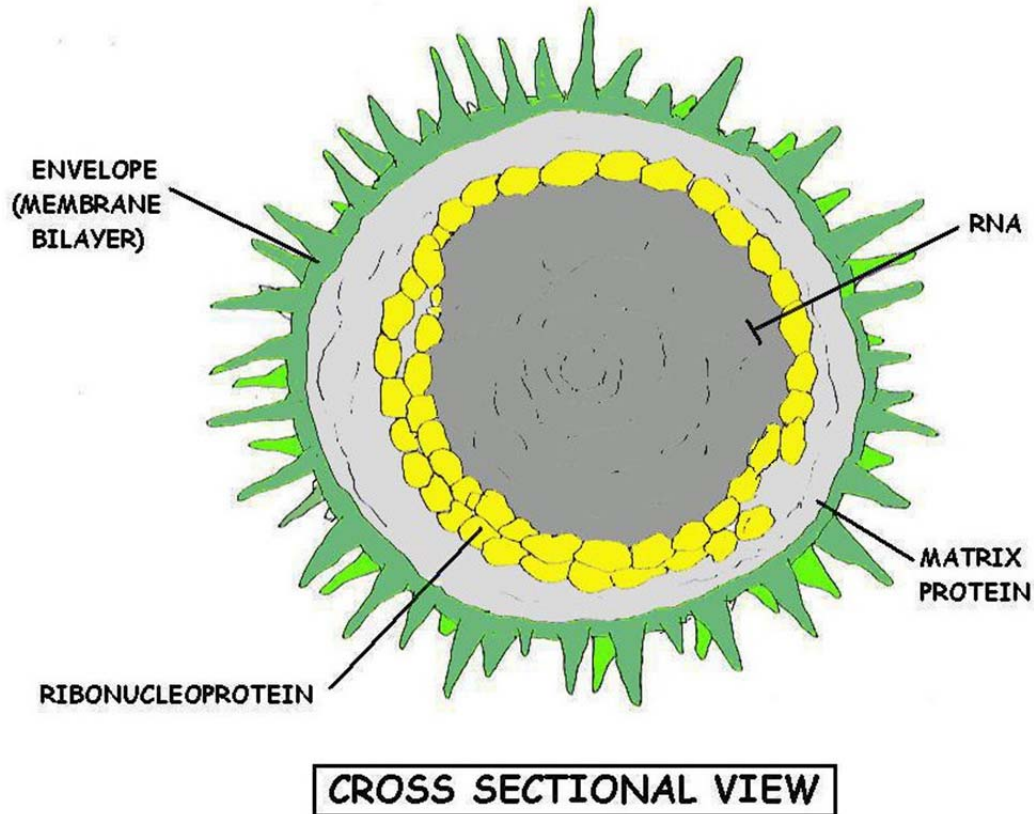

Viruses vary in size from the largest poxviruses of about 450 nanometers (about 0.000014 in) in length to the smallest polioviruses of about 30 nanometers (about 0.000001 in). Viruses are not considered free-living, since they cannot reproduce outside of a living cell; they have evolved to transmit their genetic information from one cell to another for the purpose of replication. Viruses often damage or kill the cells that they infect, causing disease in infected organisms. A few viruses stimulate cells to grow uncontrollably and produce cancers. Although many infectious diseases, such as the common cold, are caused by viruses, there are no cures for these illnesses. The difficulty in developing antiviral therapies stems from the large number of variant viruses that can cause the same disease, as well as the inability of drugs to disable a virus without disabling healthy cells. However, the development of antiviral agents is a major focus of current research, and the study of viruses has led to many discoveries important to human health.

Virions

Individual viruses, or virus particles, also called virions, contain genetic material, or genomes, in one of several forms. Unlike cellular organisms, in which the genes always are made up of DNA, viral genes may consist of either DNA or RNA. Like cell DNA, almost all viral DNA is double-stranded, and it can have either a circular or a linear arrangement. Almost all viral RNA is single-stranded; it is usually linear, and it may be either segmented (with different genes on different RNA molecules) or non-segmented (with all genes on a single piece of RNA).

Capsids

The viral protective shell, or capsid, can be either helical (spiral-shaped) or icosahedral (having 20 triangular sides). Capsids are composed of repeating units of one or a few different proteins. These units are called protomers or capsomers. The proteins that make up the virus particle are called structural proteins. Viruses also carry genes for making proteins that are never incorporated into the virus particle and are found only in infected cells. These viral proteins are called nonstructural proteins; they include factors required for the replication of the viral genome and the production of the virus particle.

Capsids and the genetic material (DNA or RNA) they contain are together referred to as nucleocapsids. Some virus particles consist only of nucleocapsids, while others contain additional structures.

Some icosahedral and helical animal viruses are enclosed in a lipid envelope acquired when the virus buds through host-cell membranes. Inserted into this envelope are glycoproteins that the viral genome directs the cell to make; these molecules bind virus particles to susceptible host cells.

Bacteriophages

The most elaborate viruses are the bacteriophages, which use bacteria as their hosts. Some bacteriophages resemble an insect with an icosahedral head attached to a tubular sheath. From the base of the sheath extend several long tail fibers that help the virus attach to the bacterium and inject its DNA to be replicated, direct capsid production, and virus particle assembly inside the cell.

Viroids and Prions

Viroids and prions are smaller than viruses, but they are similarly associated with disease. Viroids are plant pathogens that consist only of a circular, independently replicating RNA molecule. The single-stranded RNA circle collapses on itself to form a rod-like structure. The only known mammalian pathogen that resembles plant viroids is the deltavirus (hepatitis D), which requires hepatitis B virus proteins to package its RNA into virus particles. Co-infection with hepatitis B and D can produce more severe disease than can infection with hepatitis B alone. Prions are mutated forms of a normal protein found on the surface of certain animal cells.

Virus Classification

Viruses are classified according to their type of genetic material, their strategy of replication, and their structure. The International Committee on Nomenclature of Viruses (ICNV), established in 1966, devised a scheme to group viruses into families, subfamilies, genera, and species. The ICNV report published in 1995 assigned more than 4000 viruses into 71 virus families. Hundreds of other viruses remain unclassified because of the lack of sufficient information.

Cyanobacteria

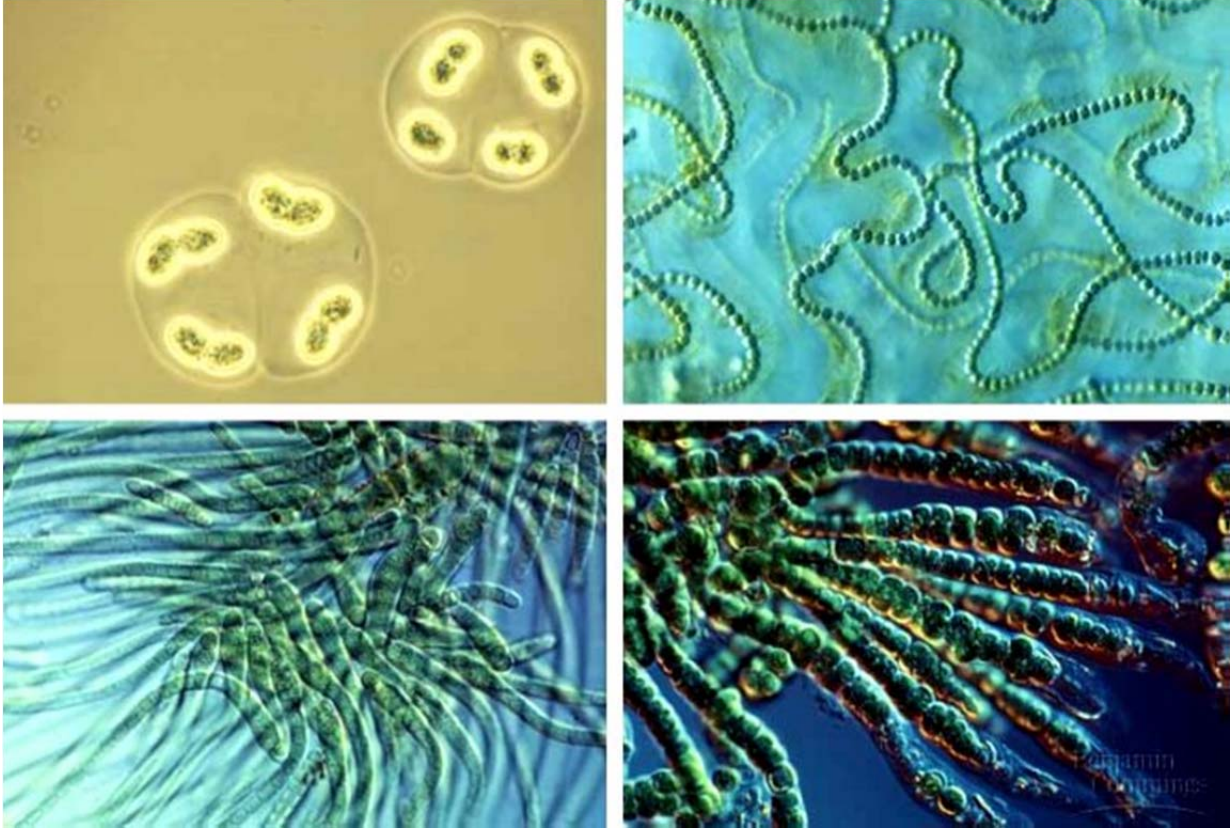

Cyanobacteria

Cyanobacteria, also known as blue-green algae, blue-green bacteria or Cyanophyta, is a phylum of bacteria that obtain their energy through photosynthesis. The name "cyanobacteria" comes from the color of the bacteria (Greek: kyanós = blue). They are a significant component of the marine nitrogen cycle and an important primary producer in many areas of the ocean, but are also found on land.

Cyanobacteria include unicellular and colonial species. Colonies may form filaments, sheets or even hollow balls. Some filamentous colonies show the ability to differentiate into several different cell types: vegetative cells, the normal, photosynthetic cells that are formed under favorable growing conditions; akinetes, the climate-resistant spores that may form when environmental conditions become harsh; and thick-walled heterocysts, which contain the enzyme nitrogenase, vital for nitrogen fixation. Heterocysts may also form under the appropriate environmental conditions (anoxic) wherever nitrogen is necessary. Heterocyst-forming species are specialized for nitrogen fixation and are able to fix nitrogen gas, which cannot be used by plants, into ammonia (NH_3), nitrites (NO_2) or nitrates (NO_3), which can be absorbed by plants and converted to protein and nucleic acids.

The rice paddies of Asia, which produce about 75% of the world's rice, could not do so were it not for healthy populations of nitrogen-fixing cyanobacteria in the rice paddy fertilizer too.

Many cyanobacteria also form motile filaments, called hormogonia, that travel away from the main biomass to bud and form new colonies elsewhere. The cells in a hormogonium are often thinner than in the vegetative state, and the cells on either end of the motile chain may be tapered. In order to break away from the parent colony, a hormogonium often must tear apart a weaker cell in a filament, called a necridium.

Each individual cell of a cyanobacterium typically has a thick, gelatinous cell wall. They differ from other gram-negative bacteria in that the quorum sensing molecules autoinducer-2[4] and acyl-homoserine lactones are absent. They lack flagella, but hormogonia and some unicellular species may move about by gliding along surfaces. In water columns some cyanobacteria float by forming gas vesicles, like in archaea.



TAKING A SAMPLE FROM A STREAM

EUGLENA

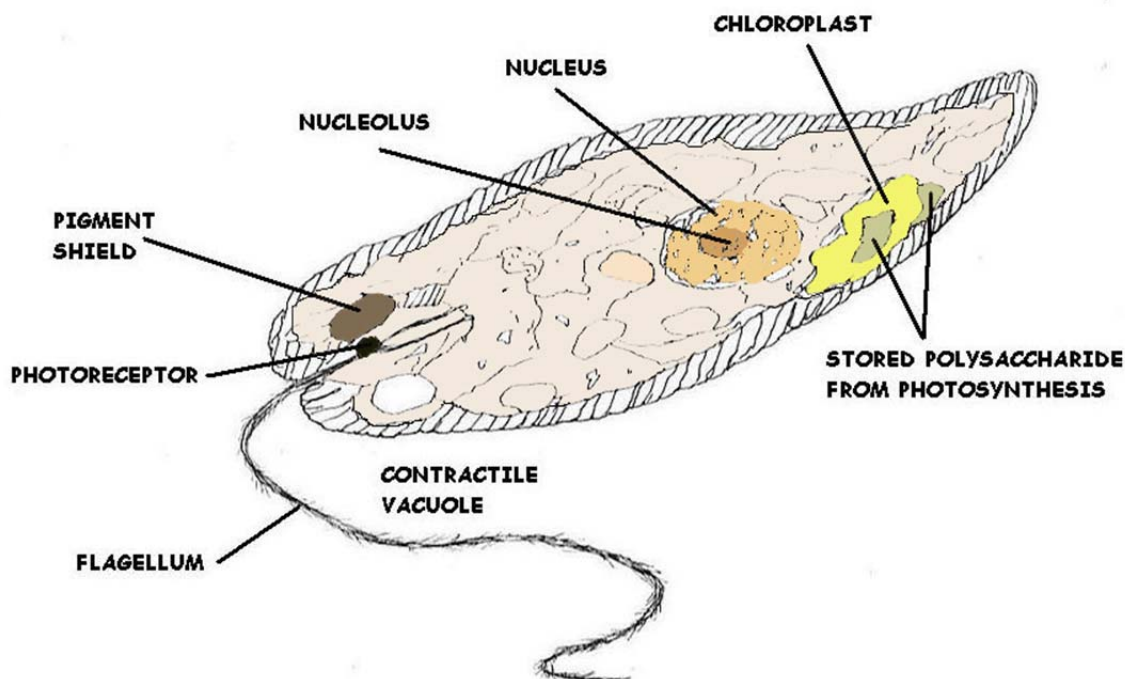

Euglena

Euglenas are common protists, of the class Euglenoidea of the phylum Euglenophyta. Currently, over 1000 species of Euglena have been described. Marin et al. (2003) revised the genus so, and including several species without chloroplasts, formerly classified as *Astasia* and *Khawkinia*. Euglena sometimes can be considered to have both plant and animal features.

Euglena gracilis has a long hair-like thing that stretches from its body. You need a very powerful microscope to see it. This is called a flagellum, and the euglena uses it to swim. It also has a red eyespot. *Euglena gracilis* uses its eyespot to locate light. Without light, it cannot use its chloroplasts to make itself food. In order for *Euglena gracilis* to make more *Euglena gracilis* it will complete a process called mitosis. That means it can split itself in half and become two *Euglena gracilis*. It can only do this if it is well-fed and if the temperature is right. *Euglena gracilis* can reproduce better in warm temperatures.

Euglena gracilis, and other euglena, are harmless to people, but they are often signs that water is polluted, since they do well where there is a lot of green algae to eat. Green algae does well where there is a lot of nitrogen (comes from waste) in the water. If you don't clean your swimming pool, leaves and twigs get in the water and turn into waste. Then algae and euglena show up.

KINGDOM: Protist, PHYLUM: Euglenophyta, CLASS: Euglenophyceae, ORDER: Euglenales, FAMILY: Euglenidae, GENUS: *Euglena*, SPECIES: *Euglena gracilis*

Peptidoglycan

Peptidoglycan, also known as murein, is a polymer consisting of sugars and amino acids that forms a mesh-like layer outside the plasma membrane of eubacteria. The sugar component consists of alternating residues of β -(1,4) linked N-acetylglucosamine and N-acetylmuramic acid residues. Attached to the N-acetylmuramic acid is a peptide chain of three to five amino acids. The peptide chain can be cross-linked to the peptide chain of another strand forming the 3D mesh-like layer.

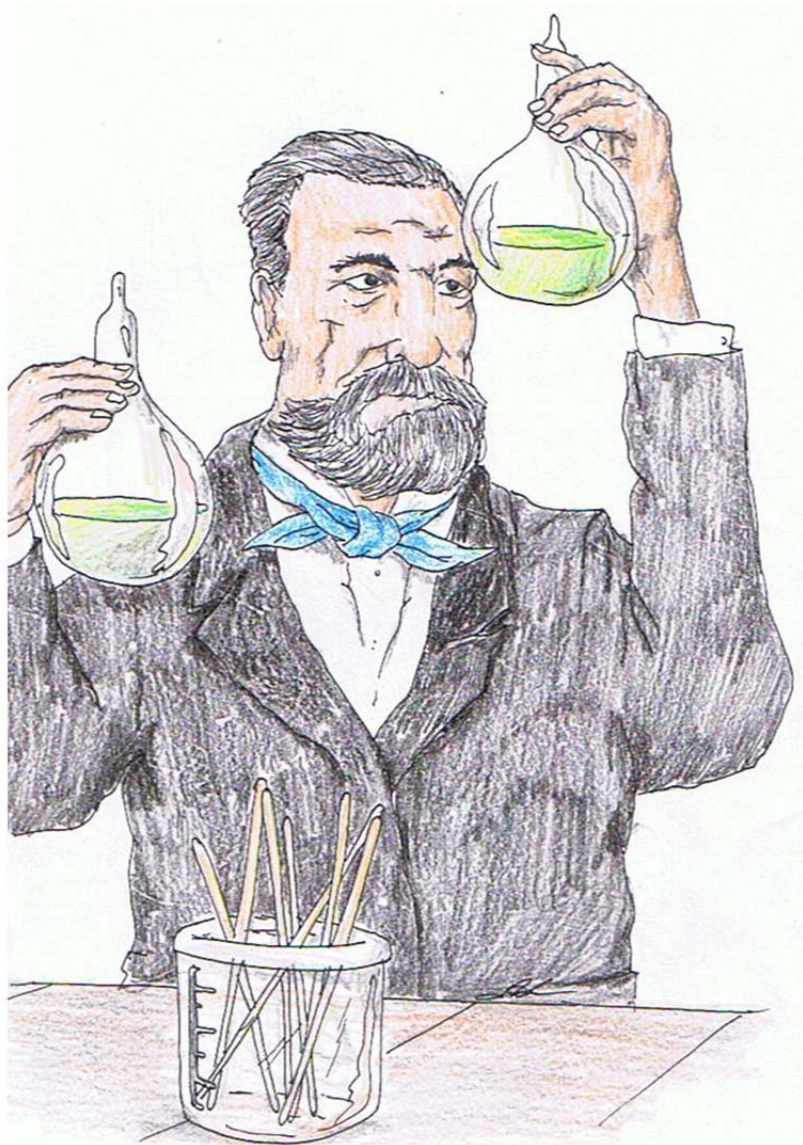

Hepatitis



HEPATITIS VIRUS

There are five types of hepatitis -- A through E -- all of which cause inflammation of the liver. Type D affects only those who also have hepatitis B, and hepatitis E is extremely rare in the United States.

- Type A hepatitis is contracted through anal-oral contact, by coming in contact with the feces of someone with hepatitis A, or by eating or drinking hepatitis A contaminated food or water.
- Type B hepatitis can be contracted from infected blood, seminal fluid, vaginal secretions, or contaminated drug needles, including tattoo or body-piercing equipment. It can also be spread from a mother to her newborn.
- Type C hepatitis is not easily spread through sex. You're more likely to get it through contact with infected blood, contaminated razors, needles, tattoo and body-piercing equipment, or manicure or pedicure tools that haven't been properly sanitized, and a mother can pass it to her baby during delivery.
- Type D hepatitis can be passed through contact with infected blood, contaminated needles, or by sexual contact with an HIV-infected person.
- Type E hepatitis is most likely to be transmitted in feces, through oral contact, or in water that's been contaminated.

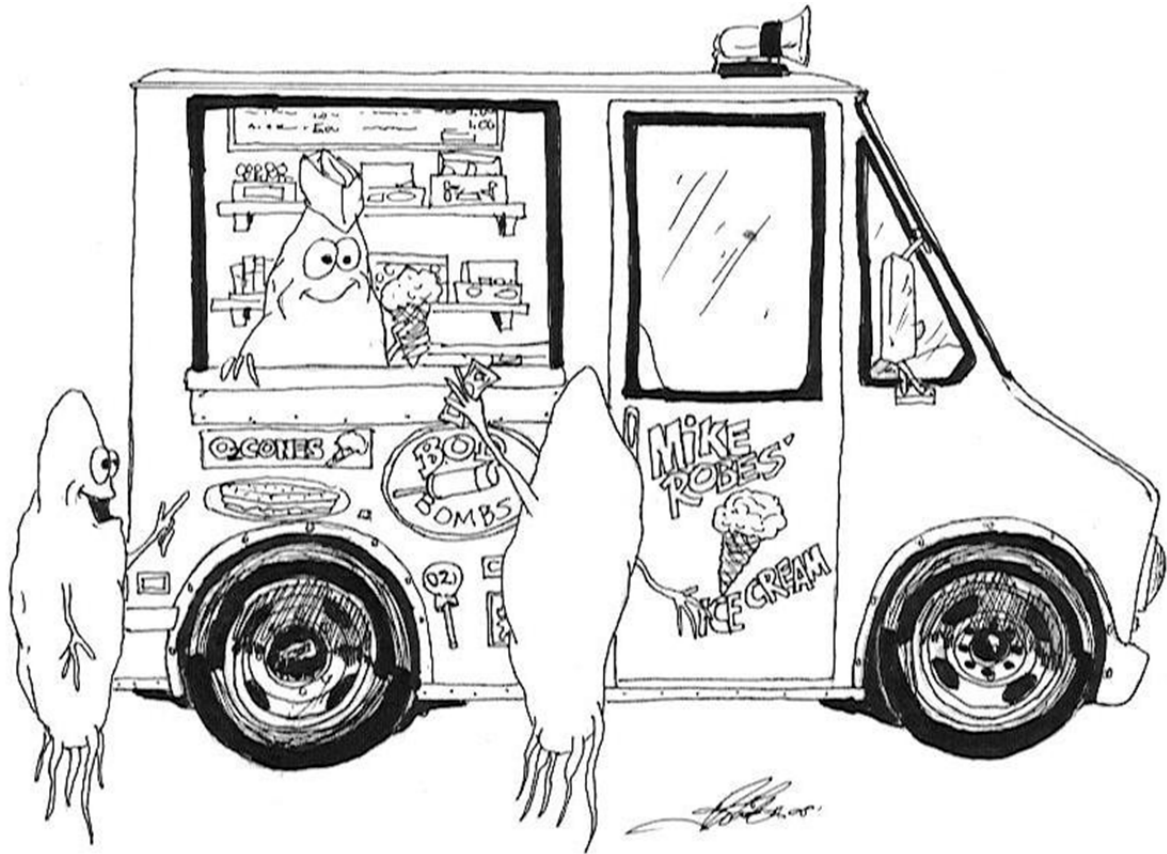

Math Conversion Factors and Practical Exercise

1 PSI = 2.31 Feet of Water
 1 Foot of Water = .433 PSI
 1.13 Feet of Water = 1 Inch of Mercury
 454 Grams = 1 Pound
 2.54 CM = Inch
 1 Gallon of Water = 8.34 Pounds
 1 mg/L = 1 PPM
 17.1 mg/L = 1 Grain/Gallon
 1% = 10,000 mg/L
 694 Gallons per Minute = MGD
 1.55 Cubic Feet per Second = 1 MGD
 60 Seconds = 1 Minute
 1440 Minutes = 1 Day
 .746 kW = 1 Horsepower

LENGTH

12 Inches = 1 Foot
 3 Feet = 1 Yard
 5280 Feet = 1 Mile

AREA

144 Square Inches = 1 Square Foot
 43,560 Square Feet = 1 Acre

VOLUME

1000 Milliliters = 1 Liter
 3.785 Liters = 1 Gallon
 231 Cubic Inches = 1 Gallon
 7.48 Gallons = 1 Cubic Foot of water
 62.38 Pounds = 1 Cubic Foot of water

Dimensions

SQUARE: Area (sq.ft.) = Length X Width
 Volume (cu.ft.) = Length (ft) X Width (ft) X Height (ft)

CIRCLE: Area (sq.ft.) = 3.14 X Radius (ft) X Radius (ft)

CYLINDER: Volume (Cu. ft) = 3.14 X Radius (ft) X Radius (ft) X Depth (ft)

PIPE VOLUME: .785 X Diameter² X Length = ? To obtain gallons multiply by 7.48

SPHERE: $\frac{(3.14) (\text{Diameter})^3}{(6)}$ Circumference = 3.14 X Diameter

General Conversions

Flowrate

Multiply	→	to get
to get	←	Divide
cc/min	1	mL/min
cfm (ft ³ /min)	28.31	L/min
cfm (ft ³ /min)	1.699	m ³ /hr
cfh (ft ³ /hr)	472	mL/min
cfh (ft ³ /hr)	0.125	GPM
GPH	63.1	mL/min
GPH	0.134	cfh
GPM	0.227	m ³ /hr
GPM	3.785	L/min
oz/min	29.57	mL/min



POUNDS PER DAY = Concentration (mg/L) X Flow (MG) X 8.34

A.K.A. Solids Applied Formula = Flow X Dose X 8.34 *Professor Rusty's Favorite Math Formula*

$$\text{PERCENT EFFICIENCY} = \frac{\text{In} - \text{Out}}{\text{In}} \times 100$$

$$\begin{aligned} \text{TEMPERATURE: } \quad {}^{\circ}\text{F} &= ({}^{\circ}\text{C} \times 9/5) + 32 & 9/5 &= 1.8 \\ {}^{\circ}\text{C} &= ({}^{\circ}\text{F} - 32) \times 5/9 & 5/9 &= .555 \end{aligned}$$

$$\text{CONCENTRATION: } \text{Conc. (A)} \times \text{Volume (A)} = \text{Conc. (B)} \times \text{Volume (B)}$$

$$\text{FLOW RATE (Q): } Q = A \times V \text{ (Quantity = Area X Velocity)}$$

$$\text{FLOW RATE (gpm): } \text{Flow Rate (gpm)} = \frac{2.83 (\text{Diameter, in})^2 (\text{Distance, in})}{\text{Height, in}}$$

$$\% \text{ SLOPE} = \frac{\text{Rise (feet)}}{\text{Run (feet)}} \times 100$$

$$\text{ACTUAL LEAKAGE} = \frac{\text{Leak Rate (GPD)}}{\text{Length (mi.)} \times \text{Diameter (in)}}$$

$$\text{VELOCITY} = \frac{\text{Distance (ft)}}{\text{Time (Sec)}}$$

N = Manning's Coefficient of Roughness

R = Hydraulic Radius (ft.)

S = Slope of Sewer (ft/ft.)

$$\text{HYDRAULIC RADIUS (ft)} = \frac{\text{Cross Sectional Area of Flow (ft)}}{\text{Wetted pipe Perimeter (ft)}}$$

$$\text{WATER HORSEPOWER} = \frac{\text{Flow (gpm)} \times \text{Head (ft)}}{3960}$$

$$\text{BRAKE HORSEPOWER} = \frac{\text{Flow (gpm)} \times \text{Head (ft)}}{3960 \times \text{Pump Efficiency}}$$

$$\text{MOTOR HORSEPOWER} = \frac{\text{Flow (gpm)} \times \text{Head (ft)}}{3960 \times \text{Pump Eff.} \times \text{Motor Eff.}}$$

$$\text{MEAN OR AVERAGE} = \frac{\text{Sum of the Values}}{\text{Number of Values}}$$

$$\text{TOTAL HEAD (ft)} = \text{Suction Lift (ft)} \times \text{Discharge Head (ft)}$$

$$\text{SURFACE LOADING RATE} = \frac{\text{Flow Rate (gpm)}}{\text{Surface Area (sq. ft)}} \text{ (gal/min/sq.ft)}$$

$$\text{MIXTURE STRENGTH (\%)} = \frac{(\text{Volume 1, gal}) (\text{Strength 1, \%}) + (\text{Volume 2, gal}) (\text{Strength 2, \%})}{(\text{Volume 1, gal}) + (\text{Volume 2, gal})}$$

$$\text{INJURY FREQUENCY RATE} = \frac{(\text{Number of Injuries}) \times 1,000,000}{\text{Number of hours worked per year}}$$

$$\text{DETENTION TIME (hrs)} = \frac{\text{Volume of Basin (gals)} \times 24 \text{ hrs}}{\text{Flow (GPD)}}$$

$$\text{SLOPE} = \frac{\text{Rise (ft)}}{\text{Run (ft)}}$$

$$\text{SLOPE (\%)} = \frac{\text{Rise (ft)} \times 100}{\text{Run (ft)}}$$

POPULATION EQUIVALENT (PE):

- 1 PE = .17 Pounds of BOD per Day
- 1 PE = .20 Pounds of Solids per Day
- 1 PE = 100 Gallons per Day

$$\text{LEAKAGE (GPD/inch)} = \frac{\text{Leakage of Water per Day (GPD)}}{\text{Sewer Diameter (inch)}}$$

$$\text{CHLORINE DEMAND (mg/L)} = \text{Chlorine Dose (mg/L)} - \text{Chlorine Residual (mg/L)}$$

τQ = Allowable time for decrease in pressure from 3.5 PSU to 2.5 PSI

τq = As below

$$\tau Q = (0.022) (d_1^2 L_1) / Q \quad \tau q = \frac{[0.085] [(d_1^2 L_1)]}{q}$$

Q = 2.0 cfm air loss

θ = .0030 cfm air loss per square foot of internal pipe surface

δ = Pipe diameter (inches)

L = Pipe Length (feet)

$$V = \frac{1.486 R^{2/3} S^{1/2}}{v}$$

V = Velocity (ft./sec.)

v = Pipe Roughness

R = Hydraulic Radius (ft)

S = Slope (ft/ft)

$$\text{HYDRAULIC RADIUS (ft)} = \frac{\text{Flow Area (ft. }^2\text{)}}{\text{Wetted Perimeter (ft.)}}$$

$$\text{WIDTH OF TRENCH (ft)} = \text{Base (ft)} + (2 \text{ Sides}) \times \frac{\text{Depth (ft }^2\text{)}}{\text{Slope}}$$



Professor Melissa explaining math formulas.

REFERENCES

- ACGIH [1991]. Documentation of the threshold limit values and biological exposure indices. 6th ed. Cincinnati, OH: American Conference of Governmental Industrial Hygienists.
- ACGIH [1994]. 1994-1995 Threshold limit values for chemical substances and physical agents and biological exposure indices. Cincinnati, OH: American Conference of Governmental Industrial Hygienists.
- ATS [1987]. Standardization of spirometry -- 1987 update. American Thoracic Society. *Am Rev Respir Dis Basic Principles of Water Treatment*, Littleton, Colorado. Tall Oaks Publishing Inc.
- Bick, H. 1972. Ciliated protozoa. An illustrated guide to the species used as biological indicators in freshwater biology. World Health Organization, Geneva. 198 pp.
- Born, Stephen M., Douglas A. Yanggen, and Alexander Zaporozec. *A Guide to Groundwater Quality Planning and Management for Local Governments*. Wisconsin Geological and Natural History Survey, Madison, WI, 1987.
- Cairns, J., and J.A. Ruthven. 1972. A test of the cosmopolitan distribution of fresh-water protozoans. *Hydrobiologia* 39:405-427.
- Cairns, J., and W.H. Yongue. 1977. Factors affecting the number of species of freshwater protozoan communities. Pages 257-303 in J. Cairns, ed. *Aquatic microbial communities*. Garland, New York.
- Cairns, J., G.R. Lanza, and B.C. Parker. 1972. Pollution related structural and functional changes in aquatic communities with emphasis on freshwater algae and protozoa. *Proceedings of the National Academy of Sciences* 124:79-127.
- CFR. Code of Federal regulations. Washington, DC: U.S. Government Printing Office, Office of the Federal Register.
- Clayton G, Clayton F [1981-1982]. *Patty's industrial hygiene and toxicology*. 3rd rev. ed. New York, NY: John Wiley & Sons.
- Concern, Inc. *Groundwater: A Community Action Guide*. Washington, D.C., 1989.
- Cross, Brad L and Jack Schulze. *City of Hurst (A Public Water Supply Protection Strategy)*. Texas Water Commission, Austin, TX, 1989.
- Curds, C.R. 1992. *Protozoa and the water industry*. Cambridge University Press, MA. 122 pp.
- Curtis, Christopher and Teri Anderson. *A Guidebook for Organizing a Community Collection Event: Household Hazardous Waste*. Pioneer Valley Planning Commission and Western Massachusetts Coalition for Safe Waste Management, West Springfield, MA, 1984.
- Curtis, Christopher, Christopher Walsh, and Michael Przybyla. *The Road Salt Management Handbook: Introducing a Reliable Strategy to Safeguard People & Water Resources*. Pioneer Valley Planning Commission, West Springfield, MA, 1986.
- DOT [1993]. 1993 Emergency response guidebook, guide 20. Washington, DC: U.S. Department of Transportation, Office of Hazardous Materials Transportation, Research and Special Programs Administration.
- Fenchel, T. 1974. Intrinsic rate increase: the relationship with body size. *Oecologia* 14:317-326.
- Fenchel, T., T. Perry, and A. Thane. 1977. Anaerobiosis and symbiosis with bacteria in free-living ciliates. *Journal of Protozoology* 24:154-163.
- Foissner, W. 1987. Soil protozoa: fundamental problems, ecological significance, adaptations in ciliates and testaceans, bioindicators, and guide to the literature. *Progress in Protistology* 2:69-212.
- Foissner, W. 1988. Taxonomic and nomenclatural revision of Stádecek's list of ciliates (Protozoa: Ciliophora) as indicators of water quality. *Hydrobiologia* 166:1-64.
- Forsberg K, Mansdorf SZ [1993]. *Quick selection guide to chemical protective clothing*. New York, NY: Van Nostrand Reinhold.
- Foster, Laurence, M.D. 1985. "Waterborne Disease - It's Our Job to Prevent It". PIPELINE newsletter, Oregon Health Division, Drinking Water Program, Portland, Oregon 1(4): 1-3.
- Foster, Laurence, M.D. 1990. "Waterborne Disease," *Methods for the Investigation and Prevention of Waterborne Disease Outbreaks*. Ed. Gunther F. Craun. Cincinnati: U.S. Environmental Protection Agency.
- Genium [1992]. Material safety data sheet No. 53. Schenectady, NY: Genium Publishing Corporation.
- Giese, A.C. 1973. *Blepharisma*. Stanford University Press, CA. 366 pp.
- Gordon, Wendy. *A Citizen's Handbook on Groundwater Protection*. Natural Resources Defense Council, New York, NY 1984.
- Grant WM [1986]. *Toxicology of the eye*. 3rd ed. Springfield, IL: Charles C Thomas.
- Harrison, Ellen Z. and Mary Ann Dickinson. *Protecting Connecticut's Groundwater: A Guide to Groundwater Protection for Local Officials*. Connecticut Department of Environmental Protection, Hartford, CT, 1984.
- Hathaway GJ, Proctor NH, Hughes JP, and Fischman ML [1991]. *Proctor and Hughes' chemical hazards of the workplace*. 3rd ed. New York, NY: Van Nostrand Reinhold.
- Hrezo, Margaret and Pat Nickinson. *Protecting Virginia's Groundwater A Handbook for Local Government Officials*. Virginia Polytechnic Institute and State University, Blacksburg, VA, 1986.
- Jaffe, Martin and Frank Dinovo. *Local Groundwater Protection*. American Planning Association, Chicago, IL, 1987.

Kreier, J.P., and J.R. Baker. 1987. Parasitic protozoa. Allen and Unwin, Boston, MA. 241 pp.

Laybourn, J., and B.J. Finlay. 1976. Respiratory energy losses related to cell weight and temperature in ciliated protozoa. *Oecologia* 44:165-174.

Lee, C.C., and T. Fenchel. 1972. Studies on ciliates associated with sea ice from Antarctica. II. Temperature responses and tolerances in ciliates from Antarctica, temperate and tropical habitats. *Archive für Protistenkunde* 114:237-244.

Lewis RJ, ed. [1993]. Lewis condensed chemical dictionary. 12th ed. New York, NY: Van Nostrand Reinhold Company.

Lide DR [1993]. CRC handbook of chemistry and physics. 73rd ed. Boca Raton, FL: CRC Press, Inc.

Loomis, George and Yael Calhoun. "Natural Resource Facts: Maintaining Your Septic System." University of Rhode Island, Providence, RI, 1988.

Macozzi, Maureen. *Groundwater- Protecting Wisconsin's Buried Treasure*. Wisconsin Department of Natural Resources, Madison, WI, 1989.

Maine Association of Conservation Commissions. *Ground Water... Maine's Hidden Resource*. Hallowell, ME, 1985.

Massachusetts Audubon Society "Local Authority for Groundwater Protection." Groundwater Information Flyer #4. Lincoln, MA, 1984.

Massachusetts Audubon Society. "Groundwater and Contamination: From the Watershed into the Well." Groundwater Information Flyer # 2. Lincoln, MA, 1984.

Massachusetts Audubon Society. "Mapping Aquifers and Recharge Areas." Groundwater Information Flyer # 3. Lincoln, MA, 1984.

Massachusetts Audubon Society. "Road Salt and Groundwater Protection." Groundwater Information Flyer # 9. Lincoln, MA, 1987.

McCann, Alyson and Thomas P Husband. "Natural Resources Facts: Household Hazardous Waste." University of Rhode Island, Providence, RI; 1988.

Mickelsen RL, Hall RC [1987]. A breakthrough time comparison of nitrile and neoprene glove materials produced by different glove manufacturers. *Am Ind Hyg Assoc J* 941-947

Mickelsen RL, Hall RC, Chern RT, Myers JR [1991]. Evaluation of a simple weight-loss method for determining the permeation of organic liquids through rubber films. *Am Ind Hyg Assoc J* 445-447

Miller, David W. *Groundwater Contamination: A Special Report*. Geraghty & Miller, Inc., Syosset, NY 1982.

Montagnes, D.J.S., D.H. Lynn, J.C. Roff, and W.D. Taylor. 1988. The annual cycle of heterotrophic planktonic ciliates in the waters surrounding the Isles of Shoals, Gulf of Maine: an assessment of their trophic role. *Marine Biology* 99:21-30.

Mullikin, Elizabeth B. *An Ounce of Prevention: A Ground Water Protection Handbook for Local Officials*. Vermont Departments of Water Resources and Environmental Engineering, Health, and Agriculture, Montpelier, VT, 1984.

Murphy, Jim. "Groundwater and Your Town: What Your Town Can Do Right Now." Connecticut Department of Environmental Protection, Hartford, CT.

National Research Council. *Ground Water Quality Protection: State and Local Strategies*. National Academy Press, Washington, D.C., 1986.

New England Interstate Water Pollution Control Commission. "Groundwater: Out of Sight Not Out of Danger." Boston, MA, 1989.

NFPA [1986]. Fire protection guide on hazardous materials. 9th ed. Quincy, MA: National Fire Protection Association.

Niederlehner, B.R., K.W. Pontasch, J.R. Pratt, and J. Cairns. 1990. Field evaluation of predictions of environmental effects from multispecies microcosm toxicity test. *Archives of Environmental Contamination and Toxicology* 19:62-71.

NIOSH [1987a]. NIOSH guide to industrial respiratory protection. Cincinnati, OH: U.S. Department of Health and Human Services, Public Health Service, Centers for Disease Control, National Institute for Occupational Safety and Health, DHHS (NIOSH) Publication No. 87-116.

NIOSH [1987b]. NIOSH respirator decision logic. Cincinnati, OH: U.S. Department of Health and Human Services, Public Health Service, Centers for Disease Control, National Institute for Occupational Safety and Health, DHHS (NIOSH) Publication No. 87-108.

NIOSH [1992]. Recommendations for occupational safety and health: Compendium of policy documents and statements. Cincinnati, OH: U.S. Department of Health and Human Services, Public Health Service, Centers for Disease Control, National Institute for Occupational Safety and Health, DHHS (NIOSH) Publication No. 92-100.

NIOSH [1994]. NIOSH manual of analytical methods. 4th ed. Cincinnati, OH: U.S. Department of Health and Human Services, Public Health Service, Centers for Disease Control, National Institute for Occupational Safety and Health, DHHS (NIOSH) Publication No. 94-113.

NIOSH [1995]. Registry of toxic effects of chemical substances: Chlorine. Cincinnati, OH: U.S. Department of Health and Human Services, Public Health Service, Centers for Disease Control, National Institute for Occupational Safety and Health, Division of Standards Development and Technology Transfer, Technical Information Branch.

NJDH [1992]. Hazardous substance fact sheet: Chlorine. Trenton, NJ: New Jersey Department of Health.

NLM [1995]. Hazardous substances data bank: Chlorine. Bethesda, MD: National Library of Medicine.

Noake, Kimberly D. Guide to *Contamination Sources for Wellhead Protection*. Draft. Massachusetts Department of Environmental Quality Engineering, Boston, MA, 1988.

Office of Drinking Water. *A Local Planning Process for Groundwater Protection*. U.S. EPA, Washington, D.C., 1989.

Office of Ground-Water Protection. *Guidelines for Delineation of Wellhead Protection Areas*. U.S. EPA, Washington, D.C., 1987.

Office of Ground-Water Protection. *Survey of State Ground Water Quality Protection Legislation Enacted From 1985 Through 1987*. U.S. EPA, Washington, D.C., 1988.

Office of Ground-Water Protection. *Wellhead Protection Programs. - Tools for Local Governments*. U.S. EPA, Washington, D.C., 1989.

Office of Ground-Water Protection. *Wellhead Protection: A Decision-Makers' Guide*. U.S. EPA, Washington, D.C., 1987.

Office of Pesticides and Toxic Substances. *Citizen's Guide to Pesticides*. U.S. EPA, Washington, D.C., 1989.

Office of Underground Storage Tanks. *Musts for USGS. - A Summary of the New Regulations for Underground Storage Tank Systems*. U.S. EPA, Washington, D.C., 1988.

Ohio Environmental Protection Agency. *Ground Water*. Columbus, OH.

Principles and Practices of Water Supply Operations, C.D. Morelli, ed. 1996.

Redlich, Susan. *Summary of Municipal Actions for Groundwater Protection in the New England/New York Region*. New England Interstate Water Pollution Control Commission, Boston, MA, 1988.

Southern Arizona Water Resources Association. "Water Warnings: Our Drinking Water.... It Takes Everyone to Keep It Clean." Tucson, AZ.

Sponenberg, Torsten D. and Jacob H. Kahn. *A Groundwater Primer for Virginians*. Virginia Polytechnic Institute and State University, Blacksburg, VA, 1984.

Taylor, W., and R. Sanders. 1991. Protozoa. Pages 37-93 in J.H. Thorp and A.P. Covich, eds. *Ecology and classification of North American freshwater invertebrates*. Academic Press, New York.

Benenson, Abram S., editor. 1990. *Control of Communicable Diseases in Man*. 15th ed. Baltimore: Victor Graphics, Inc.

Texas Water Commission. "On Dangerous Ground: The Problem of Abandoned Wells in Texas." Austin, TX, 1989.

Texas Water Commission. *The Underground Subject: An Introduction to Ground Water Issues in Texas*. Austin, TX, 1989.

U.S. Environmental Protection Agency. *Seminar Publication: Protection of Public Water Supplies from Ground-Water Contaminants*. Center for Environmental Research Information, Cincinnati, OH, 1985.

Waller, Roger M. *Ground Water and the Rural Homeowner*. U.S. Geological Survey, Reston, VA, 1988.

Water Treatment, Second Edition

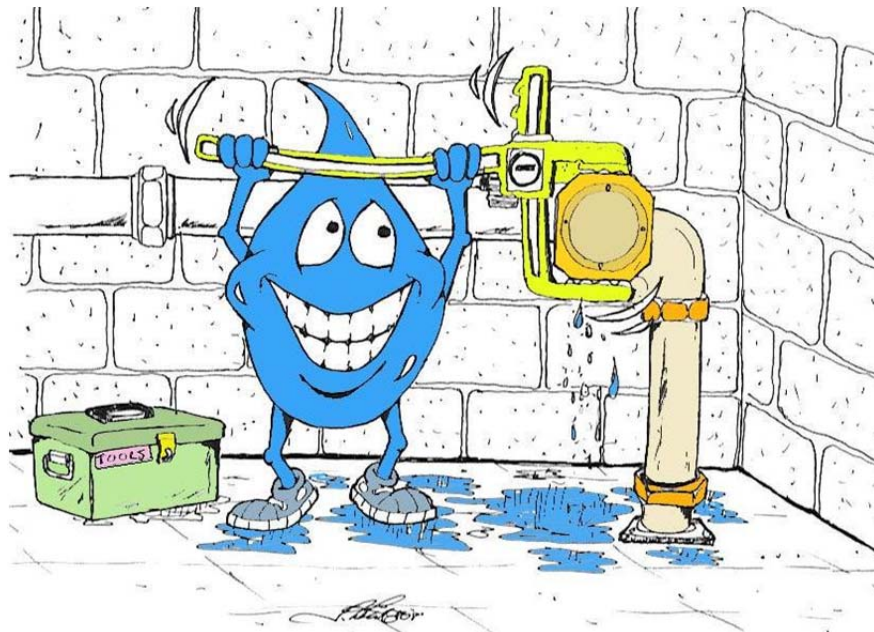



We welcome you to complete the assignment in Microsoft Word. You can easily find the assignment at www.abctlc.com. Once complete, just simply fax or e-mail the answer key along with the registration page to us and allow two weeks for grading. Once we grade it, we will mail a certificate of completion to you. Call us if you need any help. If you need your certificate back within 48 hours, you may be asked to pay a rush service fee of \$50.00.

You can download the assignment in Microsoft Word from TLC's website under the Assignment Page. www.abctlc.com You will have 90 days in order to successfully complete this assignment with a score of 70% or better. If you need any assistance, please contact TLC's Student Services. Once you are finished, please mail, e-mail or fax your answer sheet along with your registration form.