



Water Conservation — Smart Solutions for the Oil & Gas Industry

Nasser Alhajri
Operational Excellence Leader, Saudi Aramco

ORGANIZING PARTNERS



EXECUTED BY



TECHNICAL ADVISOR



6-8 March 2022 • Hilton Riyadh Hotel & Residences

Typical GOSP Overview

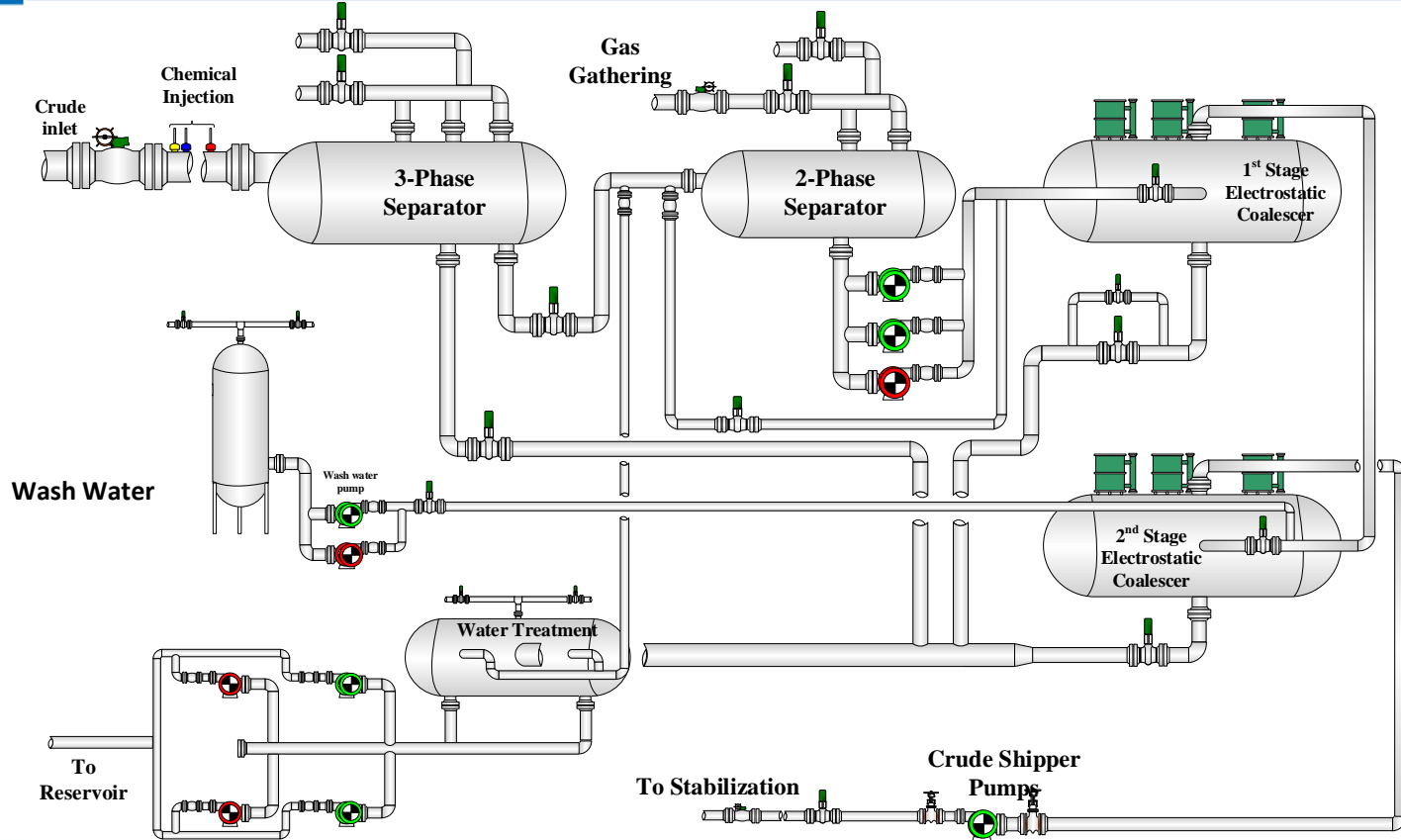

Business Drivers



Business Drivers

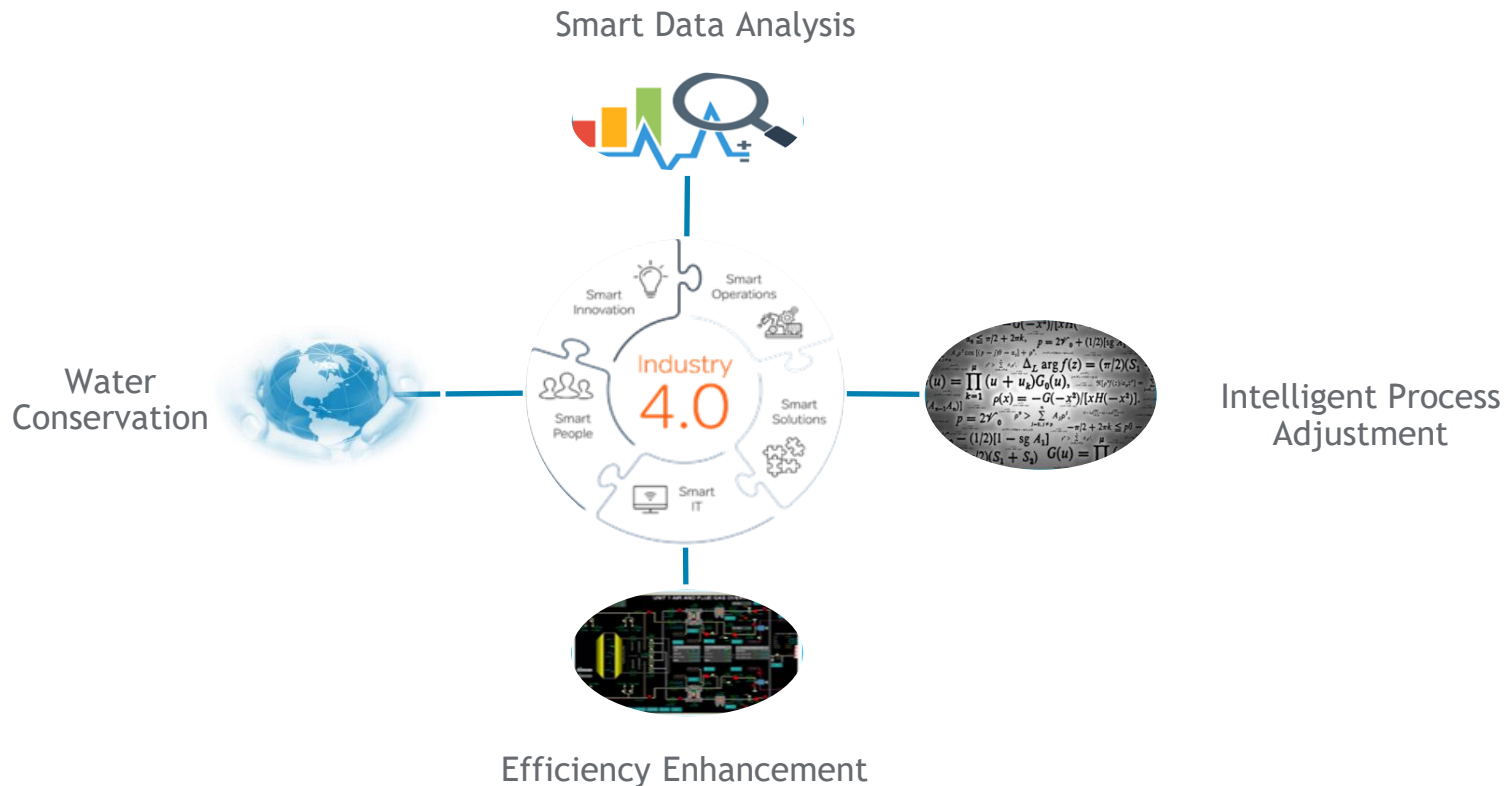

Original Setup :



Production
Rate



Manual Calculation



Manual
Adjustment



Fixed Rate

Introducing Wash Water Ratio Control

Original Setup :



Production Rate



Manual Calculation



Automatic Adjustment



Fixed Rate



In-house Innovation

15% Wash Water Optimizations

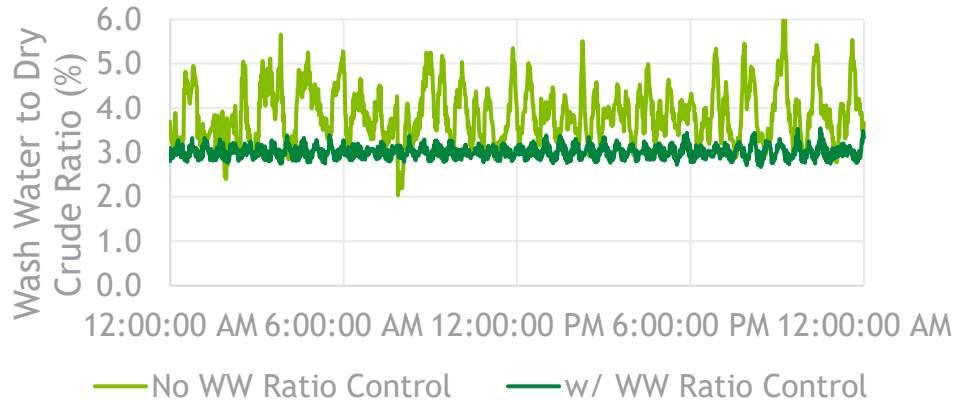

High Efficiency Mixers

Conventional Mixing



$\Delta P=15$ psi

Mixing Valve



$\Delta P=7$ psi

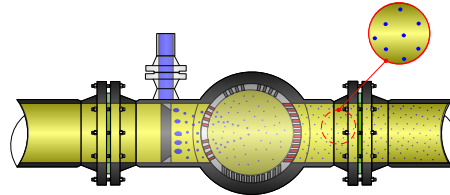
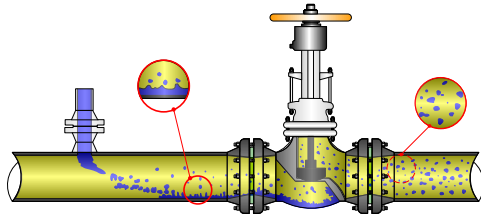

20% Wash Water Optimizations

Original Setup :

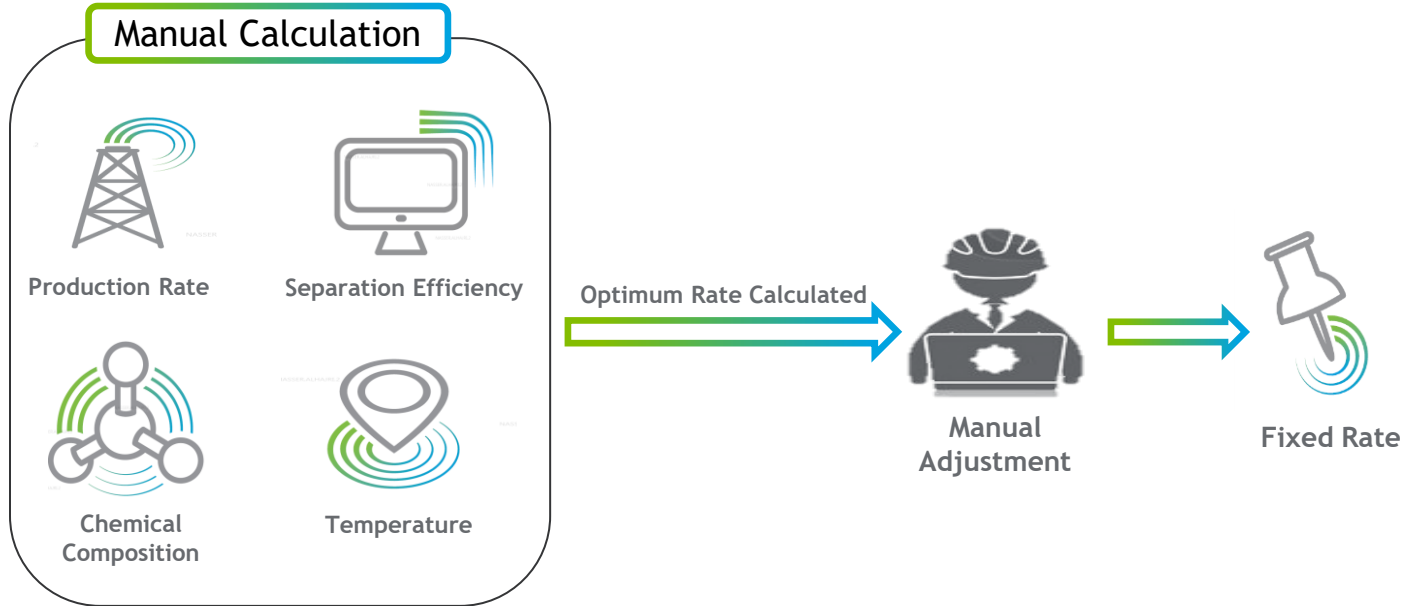

Introducing Smart Demulsifier Control

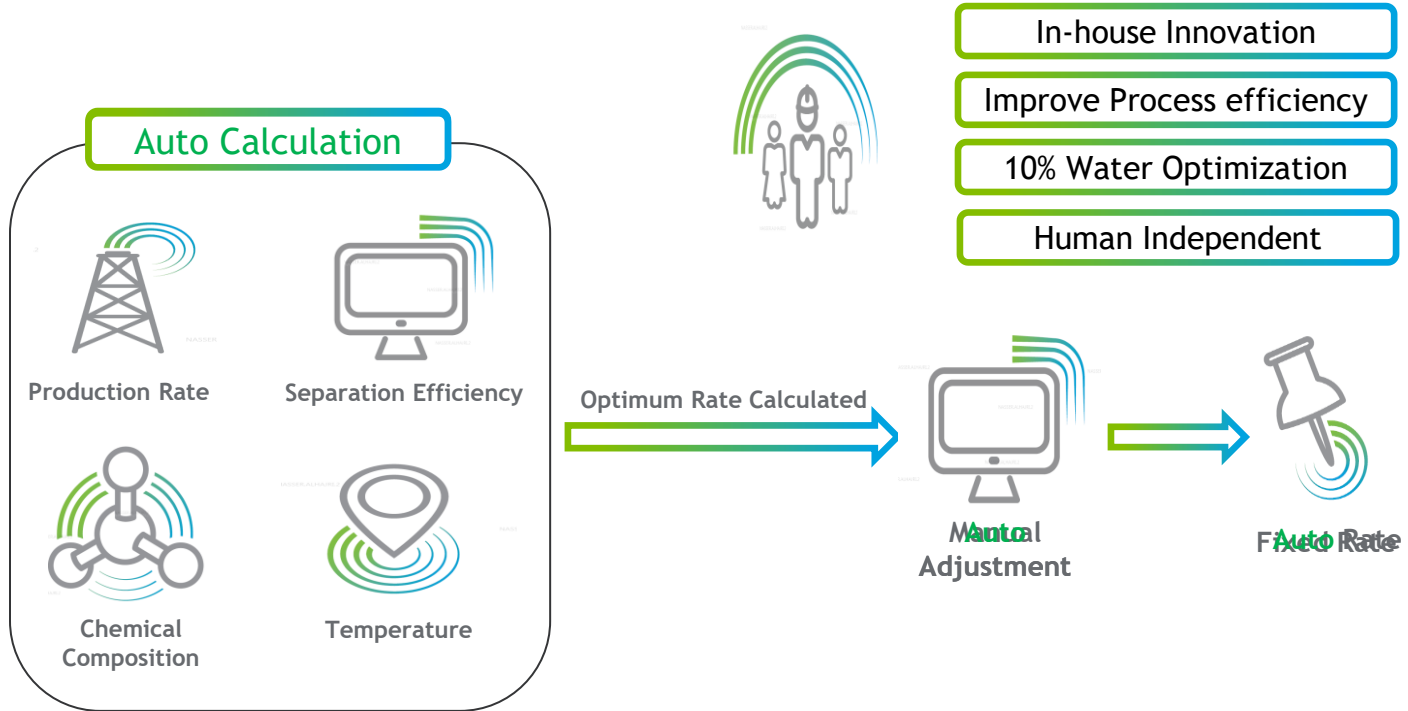

Chemical Injection

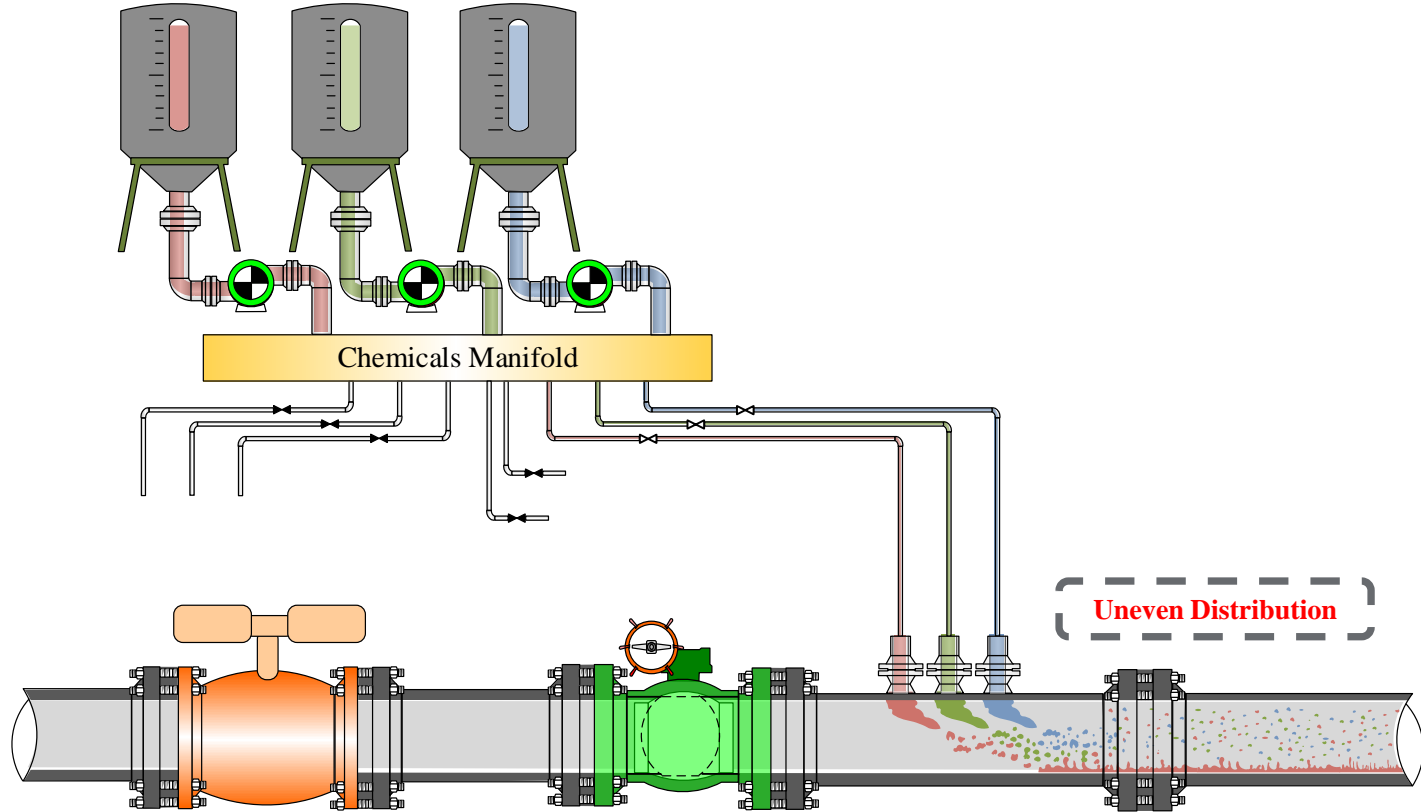

High Efficiency Mixer

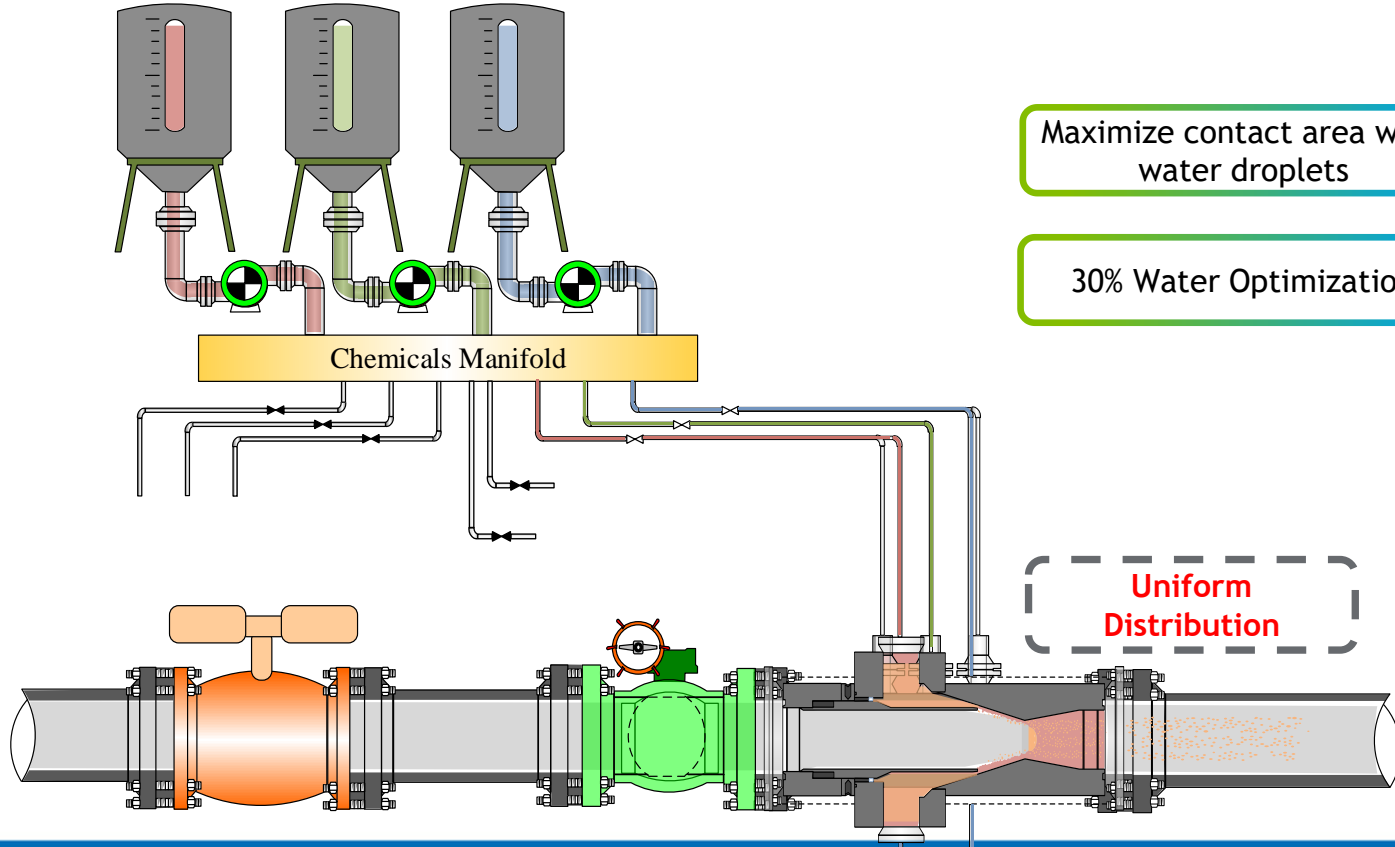

Maximize contact area with water droplets

30% Water Optimization

Uniform Distribution

Under the Patronage of **HRH Prince Faisal bin Bandar bin Abdulaziz**
Governor of Riyadh Region

وزارة البيئة والمياه والزراعة
Ministry of Environment Water & Agriculture



رؤية
2030
المتجددة
VISION
2030
SUSTAINABLE
VISION OF SAUDI ARABIA

منتدى المياه السعودي
saudi water forum **SWF 2022**
Water Sustainability.. A Responsibility for All

THANK YOU



ORGANIZING PARTNERS

الجمعية العامة لخدمة المياه بالبحرين
Bahrain Water Commission (BWC)



شركة المياه الوطنية
National Water Company



شركة المياه الوطنية
National Water Company



شركة المياه الوطنية
National Water Company



شركة المياه الوطنية
National Water Company



شركة المياه الوطنية
National Water Company



شركة المياه الوطنية
National Water Company



EXECUTED BY

SIG EXCON

TECHNICAL ADVISOR

QWI

6-8 March 2022 • Hilton Riyadh Hotel & Residences