Introduction to Membrane Techniques for Water Desalination

Course No: H03-004

Credit: 3 PDH

J. Paul Guyer, P.E., R.A., Fellow ASCE, Fellow AEI



Continuing Education and Development, Inc.
22 Stonewall Court
Woodcliff Lake, NJ 07677

P: (877) 322-5800
info@cedengineering.com

An Introduction to Membrane Techniques for Water Desalination



Guyer Partners
44240 Clubhouse Drive
El Macero, CA 95618
(530) 758-6637
jpguyer@pacbell.net

J. Paul Guyer, P.E., R.A.

Paul Guyer is a registered civil engineer, mechanical engineer, fire protection engineer, and architect with over 35 years experience in the design of buildings and related infrastructure. For an additional 9 years he was a principal advisor to the California Legislature on infrastructure and capital outlay issues. He is a graduate of Stanford University and has held numerous national, state and local offices with the American Society of Civil Engineers and National Society of Professional Engineers.

CONTENTS

1. SITE SELECTION
2. WATER SOURCE SELECTION
3. GENERAL PROCESS SELECTION
4. MEMBRANE TECHNIQUES

This course is adapted from the *Unified Facilities Criteria* of the United States government, which is in the public domain, is authorized for unlimited distribution, and is not copyrighted.

The Figures, Tables and Symbols in this document are in some cases a little difficult to read, but they are the best available. **DO NOT PURCHASE THIS COURSE IF THE FIGURES, TABLES AND SYMBOLS ARE NOT ACCEPTABLE TO YOU.**

1. SITE SELECTION

1.1 SITE TECHNICAL REQUIREMENTS. Site technical requirements are specific to each particular process. Generalized recommendations can be made regarding location, space, and access requirements. A typical desalination system flowsheet is shown in Figure 3-1. A typical desalination system layout, using reverse osmosis as a sample process, is shown in Figure 3-2.

1.1.1 LOCATION. Desalination facilities will be located as close to the raw water source as possible in order to avoid excessive pipeline or pumping costs and to minimize operation and maintenance costs for pumping raw water (high saline content). Topography should be considered in the siting of a desalination facility, and gravity flow should be used where possible.

1.1.2 SPACE REQUIREMENTS. The space required for desalination facilities is determined by the process. Membrane desalination equipment needs less space than distillation/condensation desalination equipment. In general, space requirements are less for the desalination equipment than for a conventional surface water treatment plant of the same capacity. An exception is solar desalination systems. These systems employ solar collectors that require an area several times greater than other types of desalination equipment in order to achieve equal capacity.

1.1.3 ACCESS. Access to systems must be provided to permit routine maintenance, sludge and brine removal, and delivery of desalination equipment and supplies. The access requirements for desalination facilities are similar to those for conventional water treatment facilities.

1.2 WATER STORAGE AND SYSTEM MODULARIZATION.

1.2.1 EQUIPMENT DOWNTIME. In all distillation/condensation and many membrane desalination plants, storage will be determined by equipment downtime when equipment

downtime is more than 1 day. To determine the necessary storage, establish the longest period of time that could be required for planned or unplanned maintenance. Calculate the storage by multiplying this time period by the water demand rate.

1.2.2 PEAK DAILY DEMANDS. When maximum equipment downtime is less than 1 day, the peak daily demands may set a larger storage demand.

1.2.3 FIRE WATER STORAGE. On a facility served by a desalination system, fire water may be saline water or potable water depending on economic analysis. Dual water distribution system will be required if saline water is used. Hence, part of the fire protection water can be either saline or potable water due to piping and pumping cost. Economic evaluation of various design alternatives is usually needed to assure the optimal design to be adopted.

1.2.4 SYSTEM REDUNDANCY AND MODULARIZATION. One complete and functional desalination module in excess of that required to supply the design flow will be provided as redundant capacity, and all desalination systems will have a minimum of three independently functioning desalination modules where practicable.

2. WATER SOURCE SELECTION

2.1 GENERAL. The selection of a water supply will be based on available quantity, quality, and cost of development. Investigate usable fresh surface water and groundwater thoroughly prior to consideration of sources requiring desalination. When fresh water sources do not exist, consider saline water sources. The most commonly used parameter to differentiate between saline water qualities is total dissolved solids (TDS). The total dissolved solid is defined as the sum of the dissolved organic materials and the inorganic salts. Fresh waters contain less than 1,000 milligrams per liter of total dissolved solids. Brackish water contains 1,000-20,000 milligrams per liter of total dissolved solids. Sea water usually contains at least 20,000 milligrams per liter of total dissolved solids. Quantities of potable water needed will be determined by an analysis of the site.

2.2 QUALITY. The quality will be determined by the planned use. Physical, chemical, and

bacteriological testing of source waters are required to determine the level of treatment to supply the necessary water quality. When the quantity withdrawn exceeds the recharge rate, quality inherently decreases; therefore, this must be considered during design.

2.2.1 PHYSICAL CHARACTERISTICS. The physical characteristics of the raw water source that must be evaluated are total suspended solids (TSS), temperature, turbidity and silt density index (SDI).

2.2.1.1 TOTAL SUSPENDED SOLIDS. The total suspended solids level of raw water sources must be evaluated to determine the level of pretreatment processes required. Raw water having low total suspended solids levels generally requires less pretreatment. The source with the lowest total suspended solids is preferred.

2.2.1.2 TEMPERATURE. The temperature of the raw water source must be matched to the specific desalination process. In extreme cases, the water temperature may control the desalination process selection. A climatological survey must be made prior to finalization of process selection to determine the seasonal maximum and minimum water temperatures of the proposed water sources.

2.2.1.3 TURBIDITY AND SILT DENSITY INDEX. These two characteristics provide two different measures of the amount of fine particulate matter in the water. Turbidity is measured in nephelometric turbidity units (a measure of the amount of light scattered by a known water sample thickness). Silt density index is a measure of the amount of 0.45-micron filter plugging caused by passing a sample of water through the filter for 15 minutes. Turbidity must be determined for all desalination processes. Also, the silt density index must be determined for water being considered for reverse osmosis treatment.

2.2.2 CHEMICAL CONSTITUENTS. The chemical constituents of the raw water must be determined to provide information for treatment selection. Table 2-1 shows the water testing analyses required for desalination treatment.

WATER TESTING REQUIRED FOR DESALINATION TREATMENT

TEST	PROCESS		
	<i>Electrodialysis Reversal</i>	<i>Reverse Osmosis</i>	<i>Distillation</i>
TDS	O-P	O-P	D-P
Temperature	O	O	D
Turbidity	O-P	O-P	D-P
Suspended Solids	P	P	P
Color	O-P	O-P	D-P
Corrosivity	O	O	D
Odor	P	P	P
pH	O-P	O-P	D-P
Alkalinity	O-P	O-P	D-P
Total Hardness	O-P	O-P	D-P
Noncarbonate Hardness	O-P	O-P	D-P
Carbonate Hardness	O-P	O-P	D-P
H2S	O	O	D
Chlorine Demand	O	O	D
Bacterial Contamination	O-P	O-P	D-P
Plankton	O	O	D
Oil and Grease	O	O	D
Endrin	O-P	O-P	D-P
Lindane	O-P	O-P	D-P
Methoxychlor	O-P	O-P	D-P
Toxaphene	O-P	O-P	D-P
2, 4-D	O-P	O-P	D-P
2, 4, 5-TP Silvex	O-P	O-P	D-P
Trihalomethanes	P	P	P
Ammonia	O-P	O-P	D-P
Arsenic	O-P	O-P	D-P
Barium	O-P	O-P	D-P
Cadmium	O-P	O-P	D-P
Chromium	O-P	O-P	D-P
Lead	O-P	O-P	D-P
Mercury	O-P	O-P	D-P
Nitrate	O-P	O-P	D-P
Selenium	O-P	O-P	D-P
Silver	O-P	O-P	D-P
Fluoride	O-P	O-P	D-P
Zinc	O-P	O-P	D-P
Copper	O-P	O-P	D-P
Boron	O-P	O-P	D-P
Calcium	O-P	O-P	D-P
Magnesium	O	O	D
Strontium	O	O	D
Sodium	O	O	D
Potassium	O	O	D
Bicarbonate	O	O	D
Carbonate	O	O	D
Sulfate	O-P	O-P	D-P
Chloride	O-P	O-P	D-P
Iron	O-P	O-P	D-P
Manganese	O-P	O-P	D-P
Molybdenum Reactive Silica		O	
Molybdenum Nonreactive Silica		O	
Silt Density Index		O	

Legend:

- D = Required for desalination process design
- P = Required for potable water design

Table 2-1

Water Testing Required for Desalination Treatment

2.2.3 BACTERIOLOGICAL QUALITY. The bacteriological testing of the raw water must include a type of a coliform indicator organism count. For procedures for filter membrane,

most probable number fermentation tube, and standard plate count, coliform organism bacteriological testing techniques can be found in the professional literature. Manufacturers' recommendations as to the media and procedures used to identify microbiological activity detrimental to the operation of a particular desalination system shall be followed.

2.3 SELECTION VERSUS REJECTION OF POTENTIAL RAW WATER SOURCES. After the completion of physical, chemical, and bacteriological testing, a final water source may be selected. Extreme care must be taken in the selection of a source where the usage rate is greater than the recharge rate. In most cases, selection will involve choosing the brackish water with the lowest level of total dissolved solids. When brackish water is not available, use sea water or water as the feed water source. When the coliform indicator organism count of a water is greater than 10,000 most probable number (MPN), then the water source should be rejected for sanitary reasons and a more saline water chosen (per Standard Methods for the Examination of Water and Wastewater). If other water is available, water containing more than 1,000 nephelometric turbidity units should be rejected on the basis of the high cost and difficulty of clarification, even if the alternative water is more saline. When the total delivery pumping pressure of a less saline water is greater than the operating pressure of a reverse osmosis system, then the desalination of the more saline water by reverse osmosis may be more economical than the combined cost of delivery and desalination of the less saline source. The final selection of a raw water source will be based on economic studies. In some cases, the decision cannot be made until all systems are fully designed and life cycle costed.

3. GENERAL PROCESS SELECTION

In selecting a potable water production system, it is important to estimate costs of various options. The conventional unit of comparison is cost in dollars per 1,000 gallons of product water. Water quality and energy sources will be estimated from simple site reconnaissance. For example, a sea coast site where the water source temperature exceeds 95 degrees Fahrenheit indicates a high-salinity high-temperature combination favoring distillation/condensation processes. Reverse osmosis requires a feed water temperature below 95 degrees Fahrenheit. If local well testing indicates salinity between 500 and 3,000 milligrams per liter and electricity is inexpensive, electrodialysis reversal or highflux reverse osmosis is

indicated.

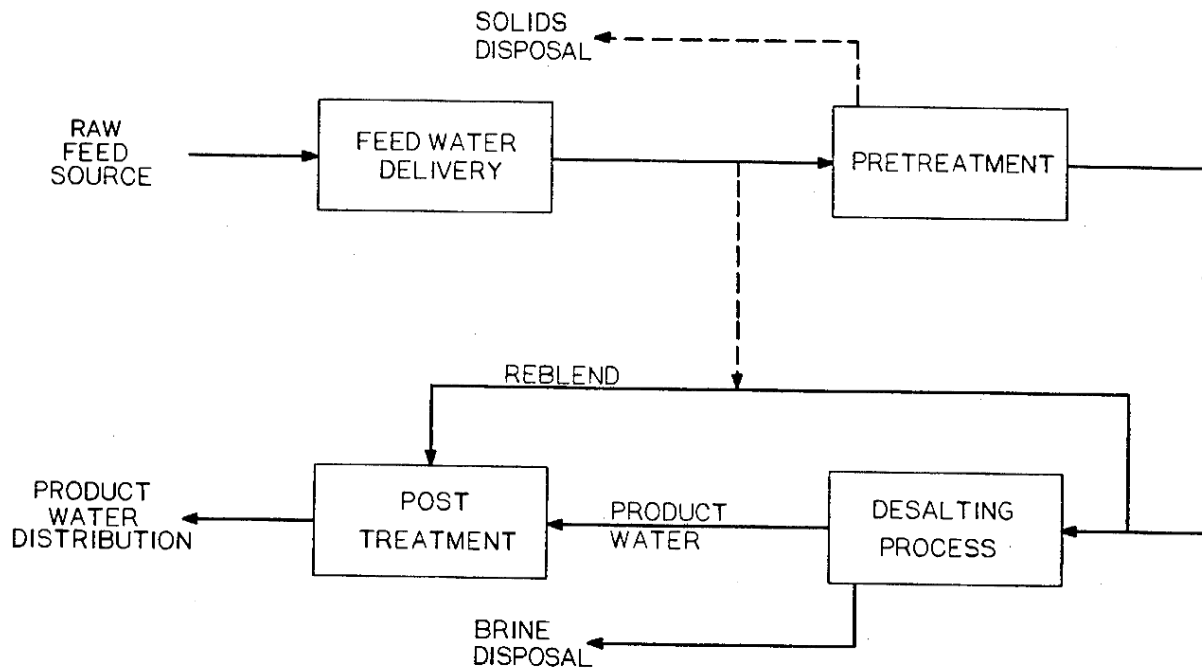

Figure 3-1
Typical desalination flowsheet

3.1 DESALINATION REQUIREMENTS. The design of a desalination system requires a clear understanding of the following: the quantity of product water desired; the quality of the desired product; and the quality of the feed water source. This course addresses the production of potable water containing less than 500 milligrams per liter of total dissolved solids. Laundries, boilers, mess halls, and hospitals may require water purer than 500 milligrams per liter of total dissolved solids. Potable water from the desalination system may be further treated to meet these requirements.

3.2 SALINE FEED WATER QUANTITY. The production of potable water from saline water usually requires a significantly larger quantity of saline feed water than the quantity of potable water produced. When desalination is necessary to produce potable water, the process splits the feed water into two streams. One stream is the product water; the other stream is the brine that contains most of the salts originally in the feed water. In waters that need very little

desalination, high-rate reverse osmosis may only reject 5 percent of the feed stream as brine. In reverse osmosis of sea water, more than 70 percent of the intake water may be rejected as brine. Multiply the required product quantity by the reciprocal of the product water recovery fraction to find the quantity of saline water that must be processed to yield the desired quantity of product water. In equation form it can be expressed as:

$$100\% \text{ recovery of product water} \times \text{water demand} = \text{saline feed water flow}$$

In some cases, the limited quantity of available saline water may require a decision to adopt a more expensive desalination process with a higher water recovery rate. However, it may require choosing a different and more saline feed water with a greater availability.

3.3 BLENDING OF WATERS. Blending a high concentration stream with a low concentration stream wastes the osmotic pressure energy between the two streams. Therefore, it is best to match the design of the desalination system to the product quality desired. When a desalination process cannot be economically matched to the desired product quality, then a process that yields water with a very low dissolved material content must be used. To conserve capital and equipment costs and meet the desired water demand, the high purity product water can be blended with the pretreated saline feed water to produce the required product quantity and quality. The following equation can be used to calculate the concentration of a blended water stream:

$$\left(\sum_{i=1}^{i=n} \text{concentration } i \times \text{flow } i \right) / \text{total flow} = \text{blended concentration}$$

When only two streams are blended, the equation can be rearranged to show the flow of concentrated water that when blended with a dilute flow will result in the desired product concentration. This rearranged equation is as follows:

$$[(P - H)(D)] / (C - P) = F$$

Where:

- P = Desired product water concentration
- H = High purity water concentration
- D = Flow of the high purity water
- C = Concentration in the impure concentrated stream
- F = Flow rate of the concentrated stream

The same blend equations will apply to blending for remineralization, which is a more common procedure.

3.4 PROCESS LIMITATIONS. The various desalination processes presently available have limitations that must be considered prior to selecting a desalination process for a particular site. These limitations apply only to the desalination processes themselves; pretreatment can be and is often used to bring a saline feed water within limits so that a desalination process can be used. The raw feed water chemistry for all desalination systems must be evaluated thoroughly for constituents that may precipitate in the desalination system.

3.4.1 HIGH-TEMPERATURE DISTILLATION. High-temperature distillation is limited by the saturation of alkaline earth metal salts, such as CaSO_4 , BaSO_4 , SrSO_4 , CaCO_3 , BaCO_3 , and SrCO_3 . Carbonate salt scaling can be controlled by acid addition. The recovery of water from a high-temperature distillation plant is usually limited by calcium sulfate solubility. When the concentration of the sulfate and the limiting alkaline earth metal is one-third of the saturated condition at ambient temperature, distillation design must include pretreatment to reduce or inhibit the scaling ions. High-temperature distillation is also limited to oil and grease levels below 1 milligram per liter. All other limitations on the high-temperature distillation process are equipment specific and require individual evaluation.

3.4.2 LOW-TEMPERATURE AND MECHANICAL DISTILLATION. Low-temperature and mechanical distillation systems are limited to operation below saturation of alkaline earth sulfates and carbonates. The lower operating temperature permits economical operation on waters that are at or below half saturation at ambient temperature. Oil and grease are limited to less than 1 milligram per liter. Any other limitations are equipment specific.

3.4.3 REVERSE OSMOSIS. The most severe limitation on reverse osmosis is the maximum limit of 50,000 milligrams per liter of total dissolved solids in the feed water. Another limitation is that there must be no iron in the feed water. This limitation is so rigid that only stainless steel and non-ferric materials will be used downstream of the iron removal. The solubility of alkaline earth sulfates and carbonates limits reverse osmosis treatment. Any water containing less than 4,000 milligrams per liter of total dissolved solids that would be saturated with an alkaline earth sulfate when the concentration is multiplied by 1.5 should not be considered for reverse osmosis desalination. Reverse osmosis is limited to waters that do not have silica saturation in the reject brine. Silica chemistry is extremely complex. When the molybdenum reactive silica concentration exceeds 30 milligrams per liter as SiO_2 or the pH exceeds 8.3 in the brine stream, an environmental chemist or engineer should be consulted. Reverse osmosis is also limited to the treatment of waters with less than 1 milligram per liter of oil and grease.

3.4.3.1 CELLULOSE ACETATE MEMBRANES. Cellulose acetate membranes are usually limited to pH levels between 4.0 and 7.5. Cellulose acetate membranes require some form of continuous disinfection with the feed water to prevent microbial degradation of the membranes and can tolerate up to 1 milligram per liter of free chlorine. Therefore, cellulose acetate membranes are usually disinfected by maintaining 0.2 to 0.9 milligrams per liter of free chlorine in the feed water. Cellulose acetate membranes cannot be used on waters where the temperature exceeds 88 degrees Fahrenheit. Cellulose acetate membranes should not be used at pressures greater than the manufacturer's recommended pressure, since they are prone to membrane degradation by pressure compaction.

3.4.3.2 POLYAROMATIC AMIDE MEMBRANES. Brackish water polyaromatic amide membranes are generally limited to operation in feed waters between pH 4 and pH 11. Polyaromatic amide membranes are less pH tolerant and should not be used outside of the range pH 5 to pH 9. All polyaromatic amide membranes are limited to use on feed streams that are free of residual chlorine. If chlorination is necessary or desirable as a pretreatment option, complete dechlorination must be effected. Polyaromatic amide membranes are tolerant of water temperatures up to 95 degrees Fahrenheit. While polyaromatic amide membranes are not as quickly or completely compacted as are cellulose acetate membranes, manufacturer's recommended pressures must be followed to prevent mechanical damage to membrane modules.

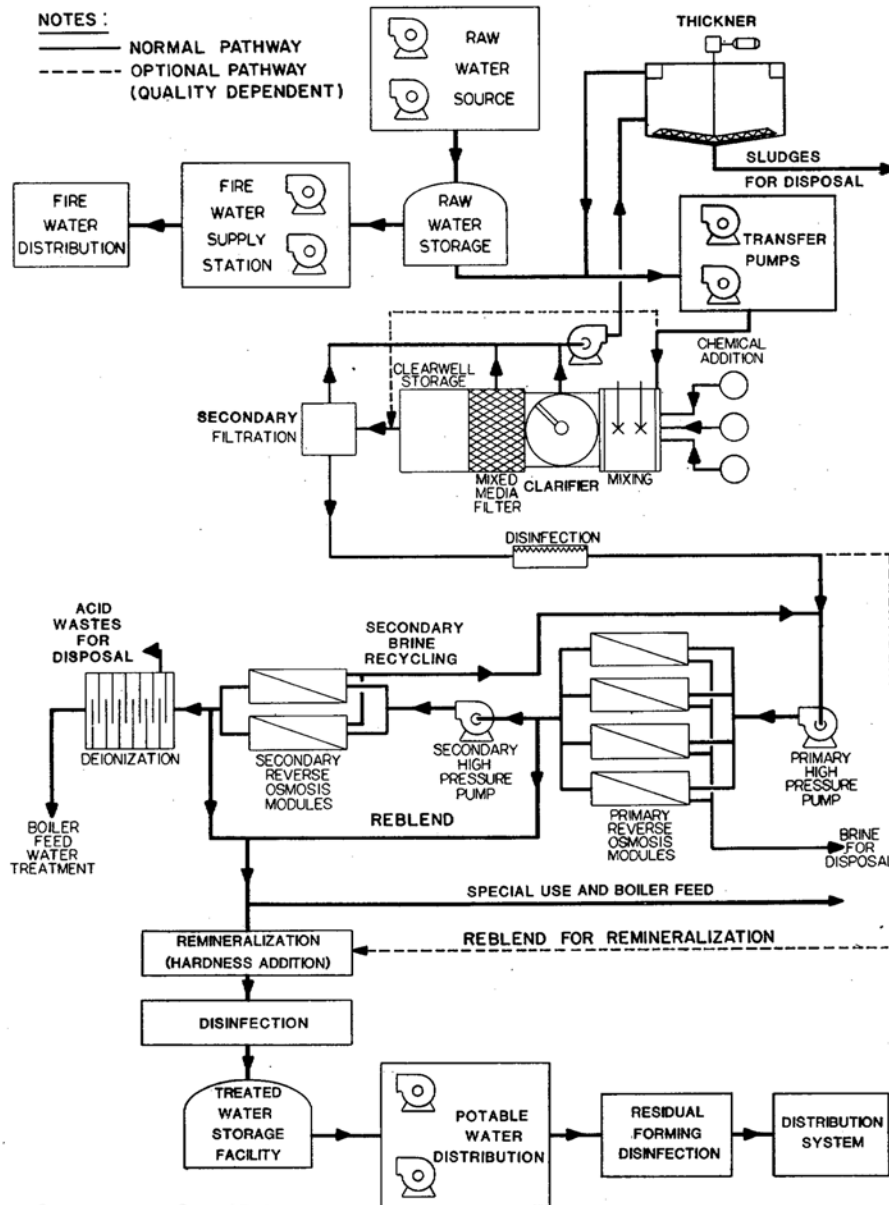

Figure 3-2

Typical reverse osmosis desalination system

3.4.4 ELECTRODIALYSIS REVERSAL. While electro dialysis reversal has been used to treat water as saline as sea water, 4,000 milligrams per liter of total dissolved solids is considered to be an upper limit for economical operation. Some electro dialysis membranes can tolerate strong oxidants, like chlorine, but most cannot. The reversal of polarity used in electro dialysis reversal for removal of scale allows operation on water that is saturated with

alkaline earth carbonates. Saturation with an alkaline sulfate with low carbonate alkalinity should be avoided.

3.5 DISTILLATION/CONDENSATION ENERGY. In distillation/condensation plants, energy is used in the form of steam and electricity. Steam is used to heat the saline water to increase its vapor pressure. Normally, electricity is used to run the compressor in vapor compression distillation. If excess steam is available, its use as a power source should be investigated.

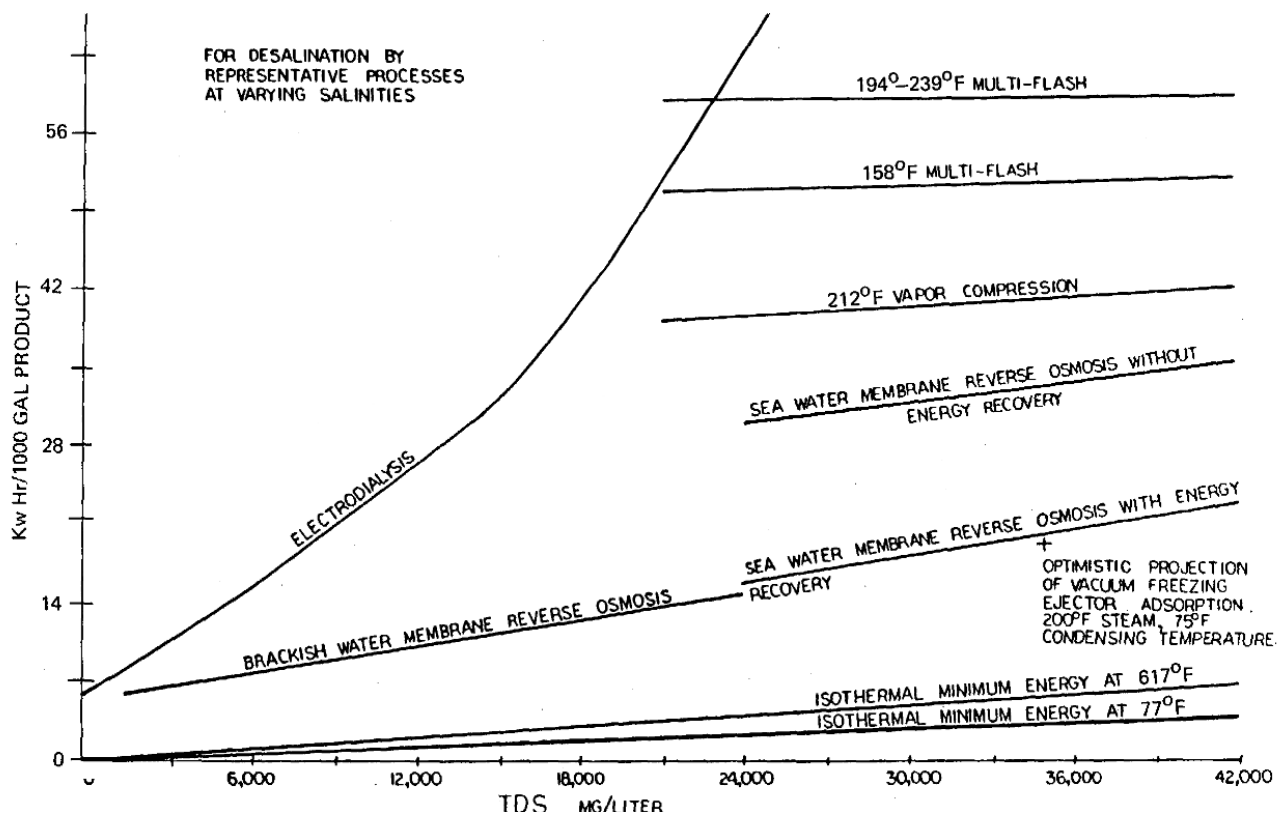

Figure 3-3
Energy Consumption

The amount of electricity or mechanical work that steam will yield depends on its temperature as well as the temperature to which it can be condensed. The energy consumption of both vapor compression and thermal distillation, as related to the total dissolved solids of feed water, is shown in Figure 3-3.

RULE	A	B	C	D	D	E
	If the freshest source of water is:	And if the desired output water will be:	And if electricity is to be generated:	And if the projected cost ratio of 264 deg F steam/ electricity:	Then investigate the cost of:	And have the following tests performed:
1	More salty than sea water	Potable water			Transportation of fresher water; distillation can be used but at great expense	Total Dissolved Solids (TDS)
2	Sea water	High-pressure boiler feed water	By steam turbine		Distillation followed by ion exchange	TDS, Ca, SO ₄ , CO ₃ , pH
3	Sea water	Potable water	By steam turbine	Greater than 10 ⁷ BTU/kwh	Thermal distillation either with or without vapor compression	TDS, Ca, SO ₄ , CO ₃ , pH
4	Sea water	Potable water	By internal combustion engine		Vapor compression distillation and waste heat	TDS, bacterial count, turbidity
5	Sea water	Potable water	No	Less than 10 ⁷ BTU/kwh	Reverse osmosis	TDS, Ca, SO ₄ , CO ₃ , pH, bacterial count, silt density index, turbidity, oil & grease
6	Brackish water	Potable water			Reverse osmosis	TDS, Ca, SO ₄ , CO ₃ , pH, bacterial count, silt density index, turbidity, oil & grease
7	Slightly saline brackish water	Potable water			Electrodialysis reversal	TDS, full ionic breakdown, bacterial count, turbidity

Table 3-1
Preliminary desalination process selection

3.6 MEMBRANE ENERGY. Historically, membrane desalination systems use less energy than other systems. Brackish water desalination should be accomplished by membrane separation processes because of the reduced energy requirement. The energy consumption of electrodialysis reversal can be made to follow reduced or variable salinity, while the energy consumption of reverse osmosis is set principally by membrane water flux. Again, the energy consumption of electrodialysis reversal and reverse osmosis as a function of the total dissolved solids content of the feed water is shown in Figure 3-3. As membrane materials are developed, energy consumption may be reduced.

3.7 WASTE DISPOSAL. Waste disposal may influence process selection. Since brine disposal costs can be an important part of process economics, brine disposal alternatives must be explored while water quality analyses are being performed.

3.8 PRELIMINARY PROCESS SELECTION. Use preliminary site information to eliminate certain desalination processes. A decision logic table for use with preliminary information is shown in Table 3-1. Decisions based upon Table 3-1 are to be considered preliminary only. Necessary water quality tests to further support the recommendations made in Column E of Table 3-1 are indicated in Column F.

3.9 PROCESS SELECTION. When initial site and raw water source selections have been made, use preliminary water quality information with Table 3-1 to assist in a preliminary process selection. As more specific information is obtained from laboratory analyses of water quality, make an initial process selection using the second decision logic Table (Table 3-2). After a treatability investigation has been completed, select the final desalination process. The use of the decision logic table sequence will only provide generalized assistance in process selection. Additional economic, engineering, and environmental studies may indicate that methods or combinations of methods must be used.

Rule	A	B	C	D	E	F
	If the feedwater TDS is (mg/liter):	And if the raw feed water suspended solids are:	And if the product of $(Ca)(SO_4)$ moles ² /liter ² in the reject brine is:	And if the oil and grease in the raw feedwater is:	Then investigate the cost of:	And have the following pretreatment processes investigated for effectiveness:
1	Greater than 50,000				Transportation of fresher water. Distillation of this water is extremely expensive.	Precipitation of less soluble salts
2	Between 20,000 and 50,000	Over 20 NTU	Considerably less than 2×10^{-4}	Greater than 10 mg/liter	Reverse osmosis or distillation and steam and electricity	Alum jar tests, pH adjustment, 10 micron or smaller filter plugging
3	Between 20,000 and 50,000	Over 1 NTU		Less than 10 mg/liter	Reverse osmosis	Alum jar tests, 10 micron or smaller filter plugging, UV sterilization
4	Between 20,000 and 50,000	Less than 1 NTU; SDI greater than 3		Less than 10 mg/liter	Spiral-wound membrane reverse osmosis	pH adjustment, UV sterilization, chlorine disinfection, chlorine residual
5	Between 20,000 and 50,000	SDI under 3		Less than 10 mg/liter	Hollow fine-fiber membrane reverse osmosis	10 micron or smaller filter test; UV sterilization
6	Between 3,000 and 20,000	Over 1,000 mg/liter	Considerably less than 2×10^{-4}	Greater than 10 mg/liter	Distillation	pH adjustment, alum jar test
7	Between 3,000 and 20,000			Less than 10 mg/liter	Reverse osmosis	pH adjustment, alum jar test, silt density index, UV sterilization
8	Between 500 and 4,000				Electrodialysis reversal	pH adjustment, alum jar test, 10 micron filter plugging, chlorine disinfection

Table 3-2

Selecting desalination processes after water quality data are obtained

4. MEMBRANE TECHNIQUES

4.1 ELECTRODIALYSIS. The ions in a water solution can be made to migrate by applying an electric field to the solution. By arranging various barriers to the flow of ions, it is possible to directly desalinate water with electricity. Such barriers are called ion-exchange membranes. Membranes that allow a reasonable flow of cations, but block or reduce the flow of anions, are called cationic-exchange membranes. Membranes that allow a reasonable flow of anions, but block or reduce the flow of cations, are called anion-exchange membranes. Membranes that pass both anions and cations are called neutral membranes.

4.1.1 THEORY. In solutions containing dissolved ions, electric currents are carried by movement of the ions. Positive ions migrate in the direction of the current flow, and negative ions migrate against the current direction. When the anions are blocked by a cationic-exchange membrane, they stop and form a localized charge at the membrane face. This accumulated negative charge is neutralized by the flow of cations across the cationic membrane. This generates a concentrated solution on the side of a cationic-exchange membrane that faces the negative electrode. It also generates a dilute solution on the side of the cationic membrane that faces the positive electrode as shown in Figure 4-1.

4.1.2 ELECTRODIALYSIS STACK. If both a cationic and anionic membrane are placed across a current flow in an electrolyte solution, the side of the cationic membrane facing the positive electrode and the side of the anionic membrane facing the negative electrode will become less saline. If the cationic membrane is closer to the negative electrode and the anionic membrane is closer to the positive electrode, the solution between the membranes will become less saline as the ions migrate in their respective directions. Any number of pairs of cationic and anionic membranes can be placed across a current-carrying solution, such that the cationic membrane is closest to the negative electrode, and the solution between will be diluted (Fig. 4-1). A battery of several such membrane pairs is called an electro dialysis stack. Several variations of the standard electro dialysis stack have been developed, but none have been proven superior to this standard stack of alternating cationic and anionic-exchange membranes to desalinate natural brackish water.

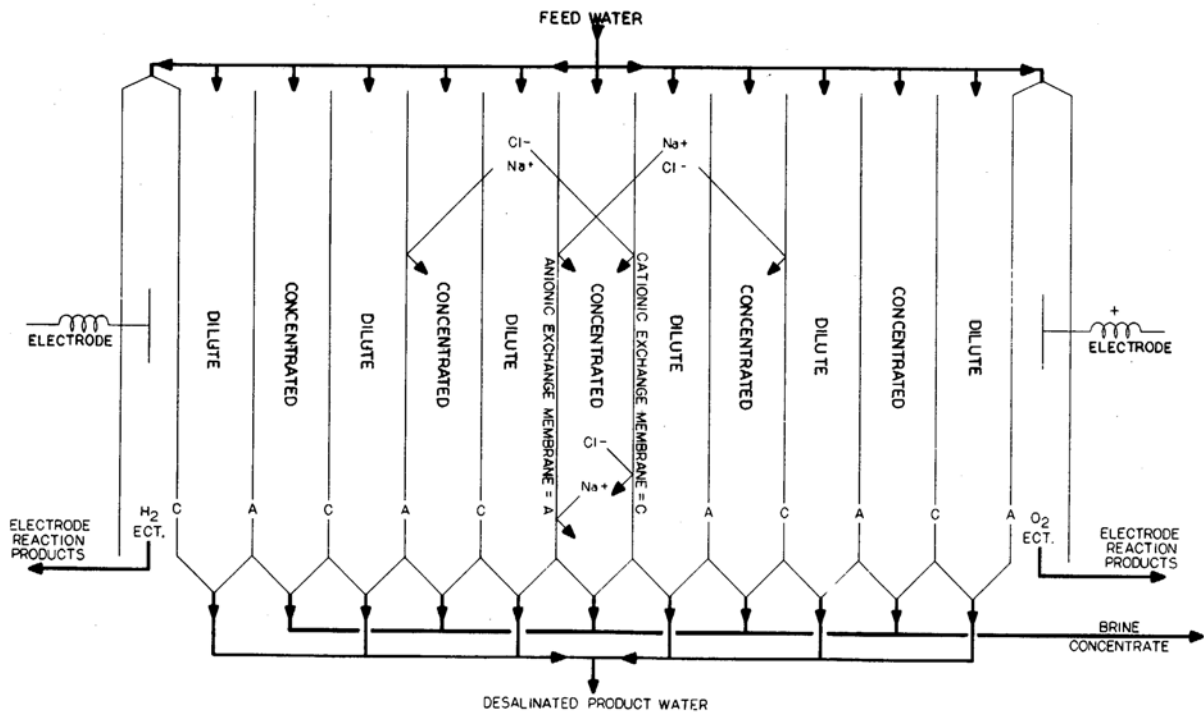

Figure 4-1

Principles of electrodesalination

4.1.3 ELECTRODIALYSIS REVERSAL. One important improvement now used in electrodesalination installations is to reverse the polarity periodically and move the ions in the opposite direction. This returns anions across the anionic membranes and helps break up scale formed on the concentrating face of the membranes. Water will flow osmotically across both membranes from the dilute product stream to the concentrated brine stream in an electrodesalination-reversal stack. This osmotic product water loss concentrates uncharged material, such as turbidity and bacteria. This concentration effect must be considered during the design to ensure meeting water turbidity and product water bacterial count requirements. Most electrodesalination membranes are not tolerant of chlorine. When possible, water desalinated by electrodesalination reversal should be disinfected after desalination is completed. The membranes should be protected by a 10-micron cartridge filter.

4.2 ELECTRODIALYSIS-REVERSAL DESIGN. When electro dialysis reversal can be shown to be the most economical process for desalination, then only an electro dialysis-reversal system will be designed. When the process selection does not yield a specific process, then designs must be prepared for more than one process.

4.2.1 IDENTIFICATION OF WORK. The design engineer will be made aware of the site and construction schedule. The location and time schedule will be considered in the design; this includes the date the system must be online. The minimum number and minimum capacity of the modules will be determined. Any restrictions that storage will place on maximum allowable downtime will also be considered. A maximum allowable output conductivity in the product water will be determined, based on the worst possible feed water.

4.2.2 EXISTING OR PLANNED FACILITIES. When electro dialysis reversal is being designed, it is essential to determine the types of available electrical power. The voltage, phase, frequency, and available amperage of all electrical power sources, planned or existing, must be considered in the design.

4.2.3 RAW WATER INFORMATION. One of two circumstances will limit the quantity of raw water consumed. Both of these limitations must be considered in the design:

- The availability of raw water may place a limitation on the raw water used in the process.
- The maximum amount of waste brine that can be economically disposed of may limit the raw water used in the process.

The principle requirement in a desalination design is an accurate projection of the chemical makeup of the worst quality water that will ever be used as raw feed water at the site being investigated. The design documentation must include maximum total dissolved solids, the individual ions, the maximum amount of total suspended solids present in the feed water, and any gas or potential corrosive agent that may be in the feed water.

4.2.4 PROCESS SPECIFICATIONS. When an electrodialysis-reversal process has been identified as most economical, the design will be limited to the single process. The process design for any electrodialysis-reversal process will include minimum/maximum allowed product water conductivity. The design must show the required product conductivity that must be obtainable at the required product flow based on the worst conductivity raw water. A 10-micron cartridge filter to be placed before the membranes must be included in the design. When a particular metallurgy or material is required for strategic, corrosion design, or process economic reasons, this metallurgy or material will be designated for all applicable parts, spare parts and equipment. All required instrumentation, including a voltmeter and an ammeter, for each electrodialysis-reversal stack must be designed. The system design must be based on equipment with a history of water treatment system experience. The required experience history should include a minimum of 2 years of operating experience meeting water quality and system design goals, current operating capacity, maximum allowable repair frequency and duration, and maximum allowable ratio of experienced capital cost to repair cost. The requirement for successful experience will limit the amount of untested innovation used at a facility.

4.3 REVERSE OSMOSIS. Diffusion through materials is influenced by the nature of the diffusing material. A number of materials allow water to pass through with relative ease. Some of these materials allow only a minute passage of ionized material compared to the passage of water through them. These semipermeable materials are used for desalination. If a thin barrier or membrane is used, water can be forced through the membrane while ions are stopped by the membrane. In general, non-ionized materials, such as some gases and many organics, will not be removed by these membranes. Some larger organic molecules may not pass through the membranes.

4.3.1 OSMOTIC PRESSURE. When a semipermeable membrane that will pass solvent is placed between two solutions of different concentrations containing the same solvent at identical temperatures, the solvent must pass from the less concentrated to the more concentrated solution as shown in Figure 4-2. This flow of solvent produces a pressure head difference. The equilibrium liquid pressure head difference is called the osmotic pressure difference of the solutions. If these pressures are reversed, pure water will be forced from the

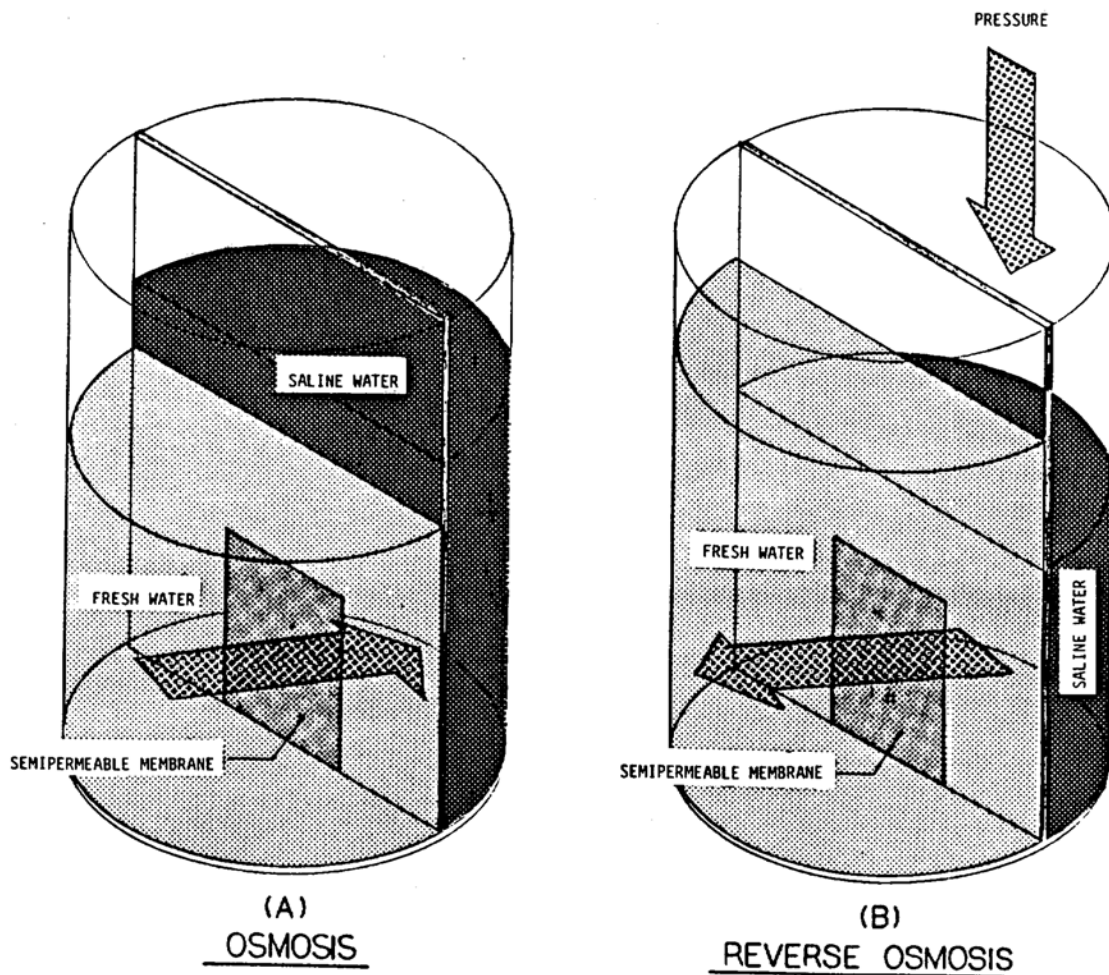

Figure 4-2
Reverse osmosis principles

more concentrated solution through the membrane into the less concentrated solution, provided that the pressure differential exceeds the osmotic pressure. A typical reverse osmosis flow sheet is shown in Figure 4-3.

4.3.2 ENERGY RECOVERY. Reverse osmosis produces concentrated, high-pressure brine. With reverse osmosis, the energy lost in depressurizing the brine can be returned efficiently to the feed water by mechanical methods. In small systems, consider a flow-work exchanger; in large systems, consider an energy recovery turbine.

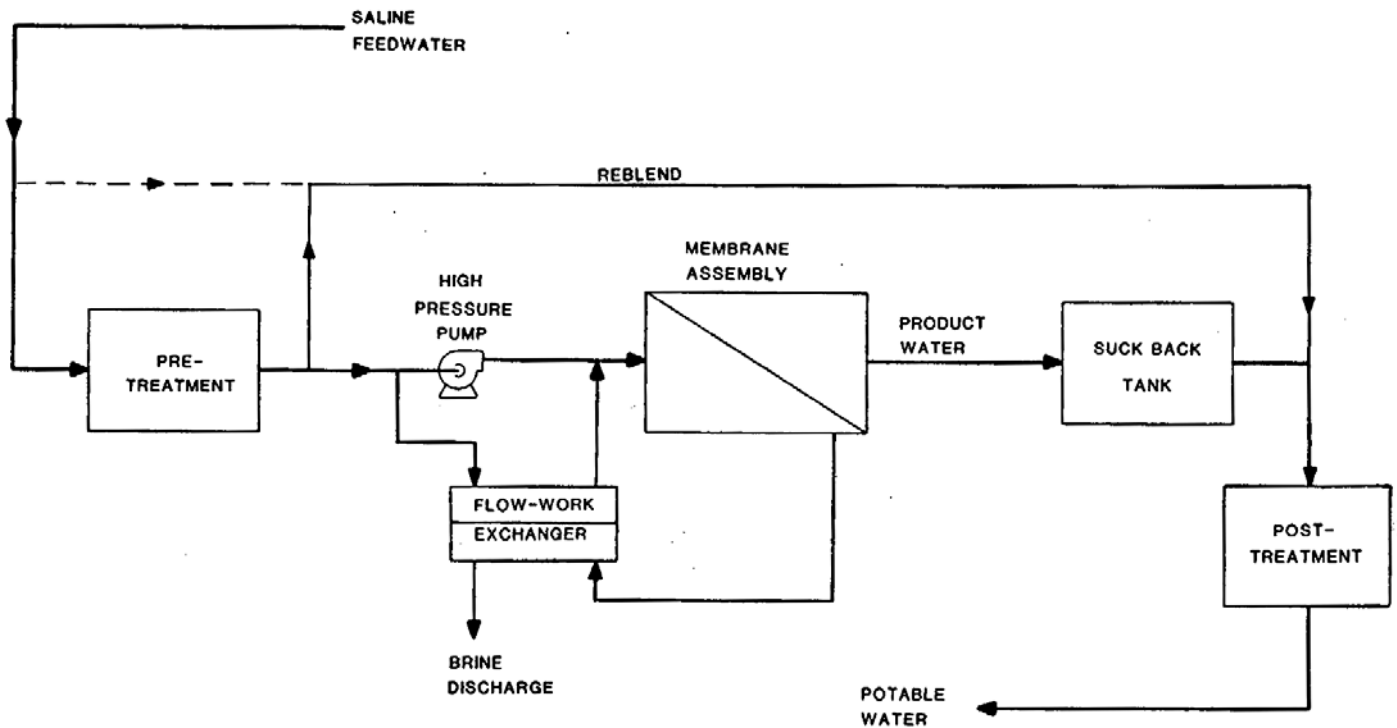

Figure 4-3
Reverse osmosis desalination system

4.3.2.1 FLOW-WORK EXCHANGER. A flow-work exchanger, Figure 4-4, is a simple piston driven by pressurized brine to compress the saline feed. When the piston has traveled a full stroke, the valving is changed, and the saline feed is used to expel depressurized brine. Flow-work exchangers have been under development since 1980.

4.3.2.2 ENERGY RECOVERY TURBINES. Several large reverse osmosis systems have been built with energy recovery turbines. These turbines can be installed to assist directly in pumping or to drive synchronous motors and generate electricity. While reverse osmosis is an energy efficient desalination process for highly saline waters, energy recovery can reduce the amount of energy used by as much as one-third.

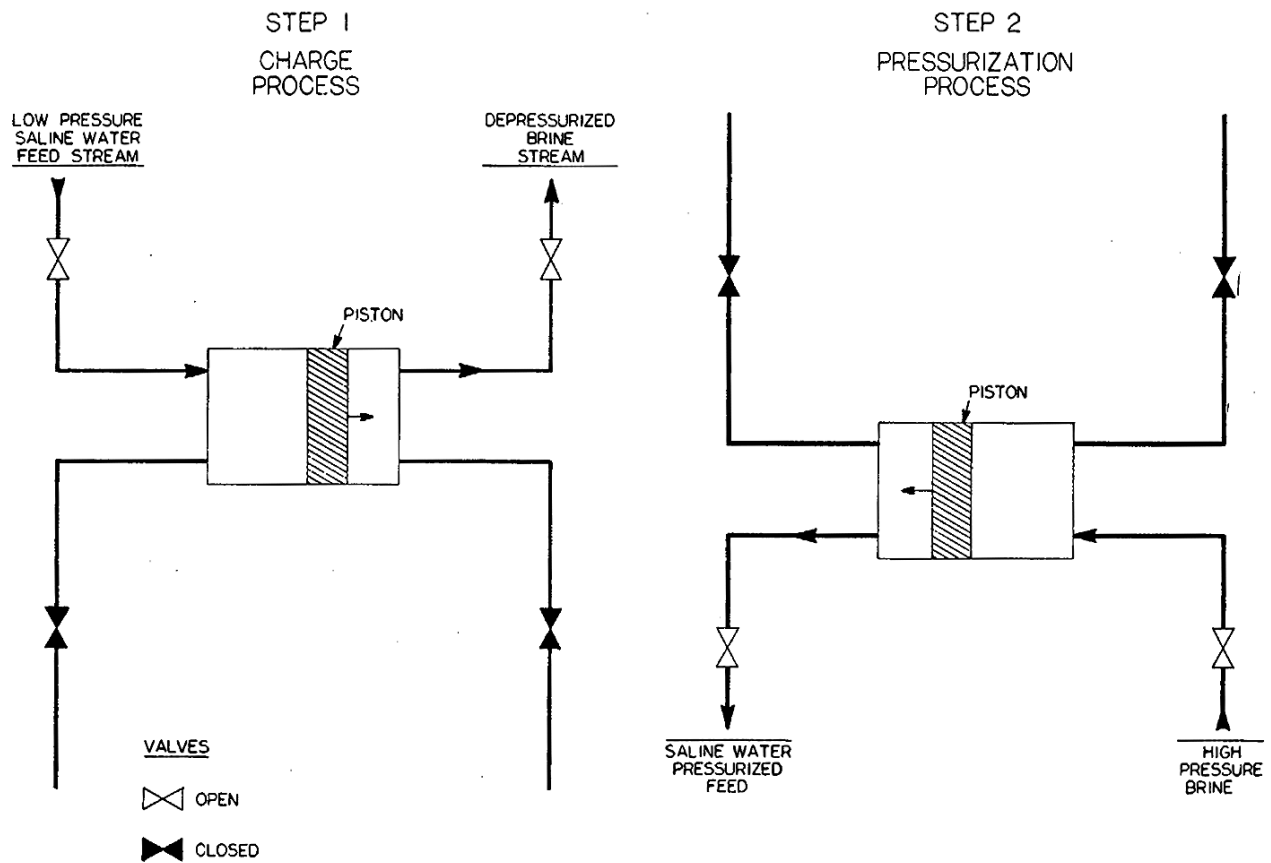

Figure 4-4
Flow-work exchanger principles

4.3.3 MECHANICAL STRENGTH AND PACKING OF MEMBRANES. For containment of high pressures with thin membranes in reverse osmosis, three alternative arrangements have been developed.

4.3.3.1 POROUS TUBES. Porous tubes lined with semipermeable membrane material have been developed for concentration of valuable products in industry. Such systems are no longer used for water desalination. A packing density of less than 110 square feet of surface

area per cubic foot of volume makes this configuration too expensive for water production. See Figure 4-5.

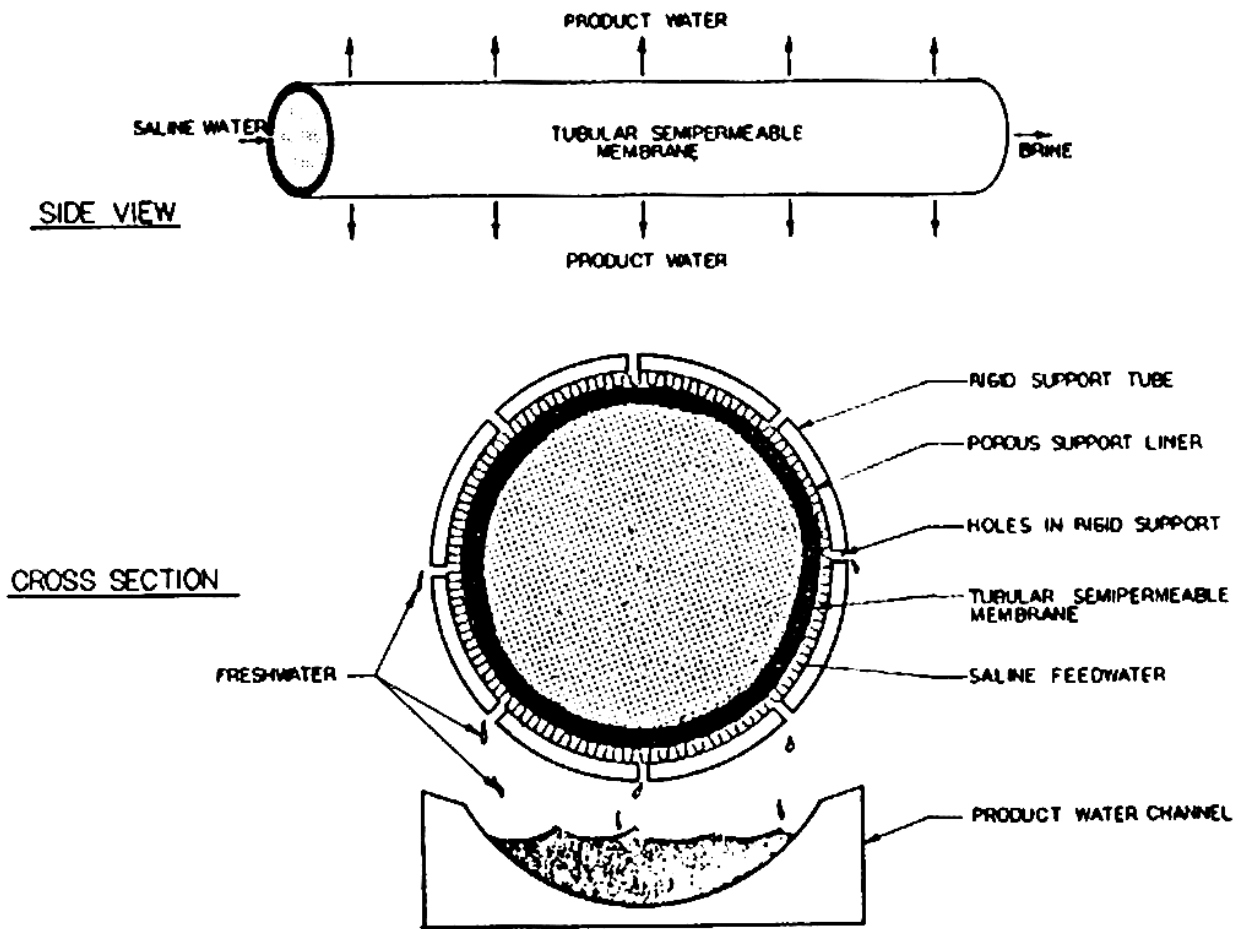

Figure 4-5

Construction of a tubular reverse osmosis membrane

4.3.3.2 SPIRAL-WOUND MEMBRANES. By using spacers it is possible to roll a membrane envelope onto a slotted product water tube as shown in Figure 4-6. This reverse osmosis membrane configuration is known as the spiral-wound configuration. This arrangement allows

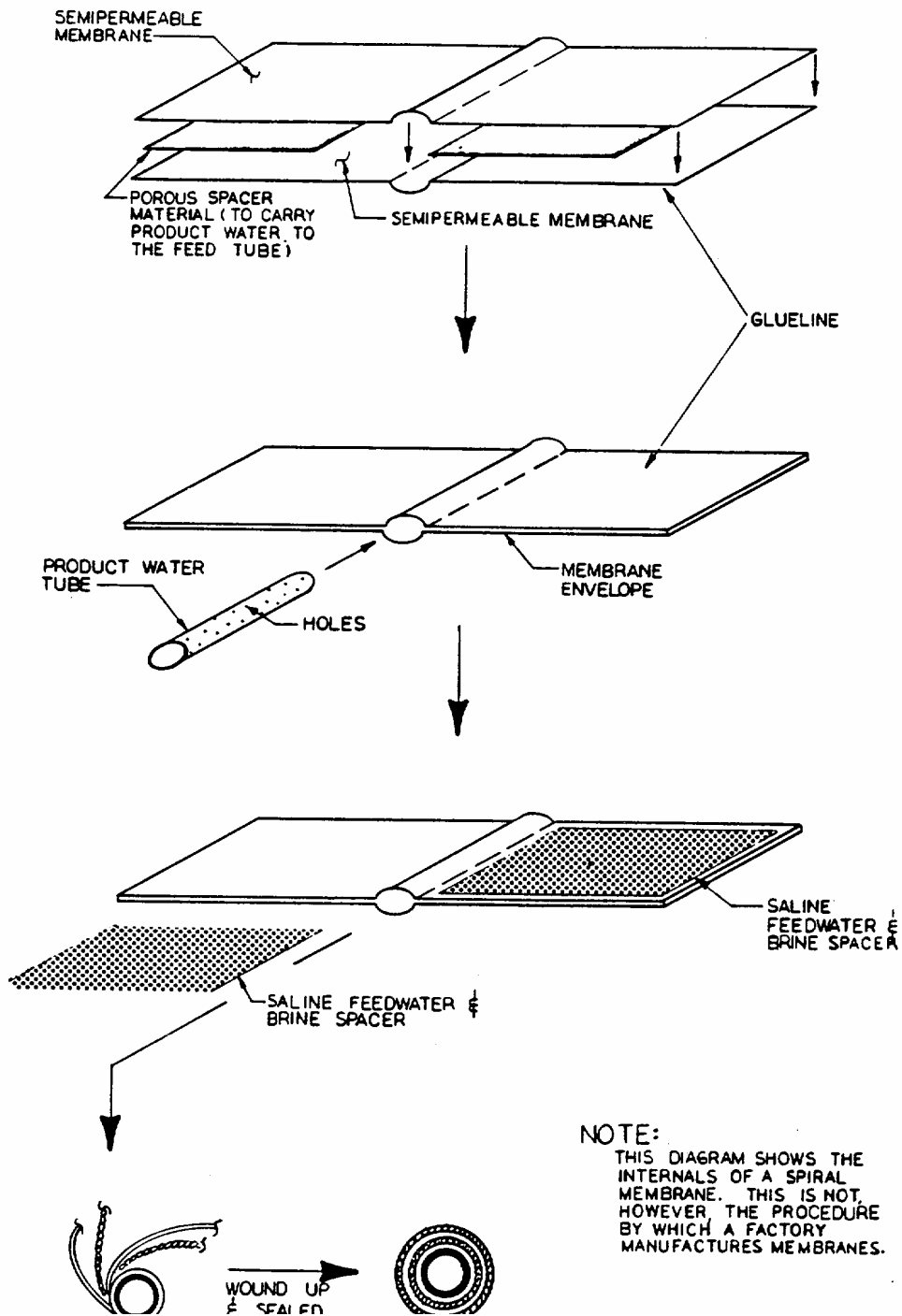

Figure 4-6
Internal construction of a spiral-wound membrane

for surface densities of greater than 250 square feet of surface area per cubic foot of volume. With the development of this spiral-wound configuration, water production from brackish water sources by reverse osmosis became economical in many applications. See Figure 4-6.

4.3.3.3 HOLLOW FINE FIBERS. A large research and development effort made it possible to coat minute hollow fibers, smaller in diameter than a human hair, with semipermeable membrane material. This reverse osmosis membrane configuration is known as the hollow fine-fiber configuration. Packing densities with hollow fine fibers have exceeded 4,900 square feet of surface area per cubic foot of volume. See Figure 4-7.

4.3.4 MEMBRANE MATERIALS. There are a number of successful reverse osmosis membrane materials. Currently, two principal types of membrane materials are being used: cellulose acetate and polyaromatic amide. Both materials are destroyed by dehydration of the membranes. To avoid dehydration, product water must be supplied to allow osmotic water to flow back through the membranes in order to dilute the feed water to approximate product water concentrations. If product water is not supplied, then the osmotic suction will draw air back into the membranes and dehydrate them, if the feed water side of the membrane is depressurized. Usually, the required volume of product water is supplied by a suck-back tank, which maintains a minimum volume and back pressure on the reverse osmosis membranes.

4.3.4.1 CELLULOSE ACETATES. This material suffers from slow chemical decomposition through a process called hydrolysis. The use of acids to prevent scaling increases the rate of this form of membrane decay. Cellulose acetates are also biodegradable and must be protected from bacterial attack. One of the important advantages of cellulose acetate is its resistance to attack by chlorine. Most cellulose acetate membranes can be used with feed waters containing less than 1 milligram per liter of residual chlorine, which will protect the membranes from biological attack.

4.3.4.2 POLYAROMATIC AMIDES. These membranes are stable, biologically and chemically. Despite this chemical stability, these membranes cannot tolerate any residual oxidant. If chlorination is required to reduce the amount of biological suspended solids, then dechlorination must be complete if polyaromatic amide membranes are used.

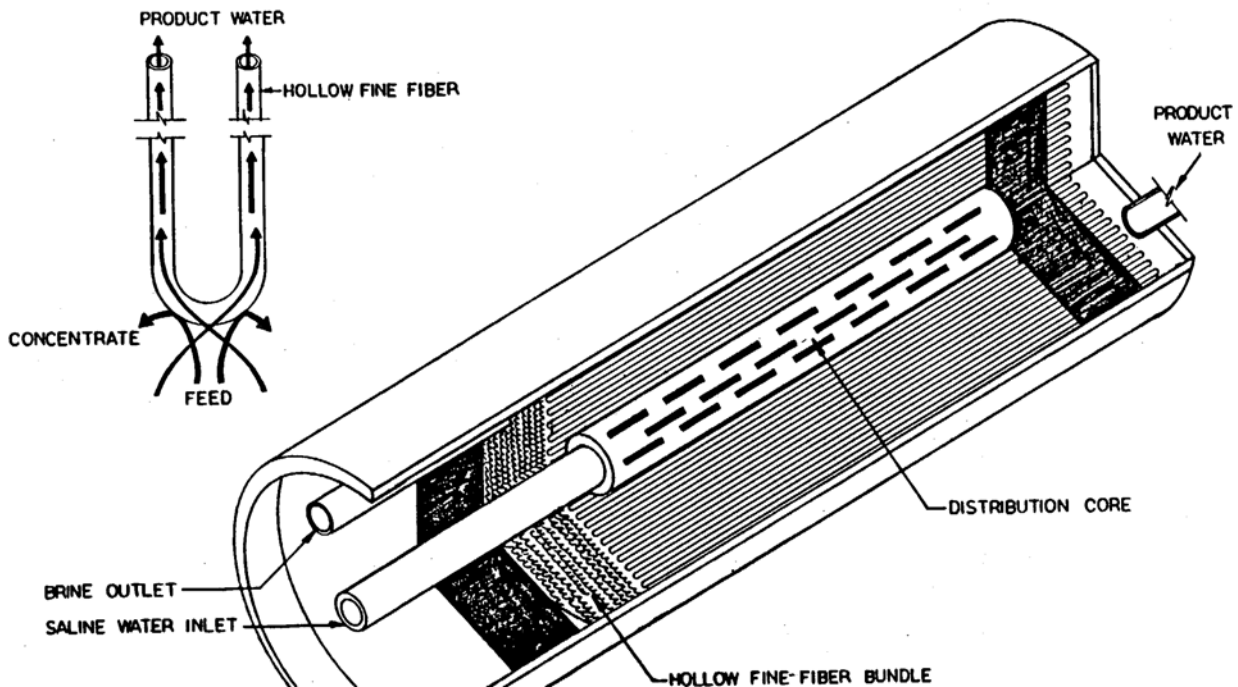

Figure 4-7

Internal construction of a hollow fine-fiber reverse osmosis membrane module

4.4 REVERSE OSMOSIS MEMBRANE STAGING CONFIGURATIONS. Two kinds of membrane staging are commonly used in reverse osmosis desalination plants: product staging and reject staging. Reject staging is used to treat waters with low salinity, so that most of the raw feed water will eventually be recovered as product water. Product staging is used to treat highly saline waters, whose product water salinity cannot be reduced to the required concentration by a single pass through the membrane under consideration. Banking is the term usually used for parallel arrangement of a number of membrane modules operating from the discharge of a single pump. Banking of membranes usually requires a flow restraint on the brine reject of each module in the bank. A pigtail of nylon tubing is often used for this flow equalization headloss. This pressure drop maintains a balanced flow of brine out of each membrane module in the bank. Unbalanced flow can shorten the useful life of membrane modules. While higher flow rates will tend to clean membranes, excessive flow can fatigue or fray both spiral and hollow fine-fiber membranes. Low flow rates allow the concentrated brine to stagnate, which leads to scaling and fouling of membrane surfaces.

4.4.1 PRODUCT STAGING. Product staging is true series operation of two or more reverse osmosis membrane systems, as shown in Figure 4-8. Product staging is used when a single pass through one reverse osmosis membrane does not bring a constituent concentration down to specification. The second stage always requires its own pressurizing pump, taking suction from the suck-back or storage tank of the first stage reverse osmosis system. When the water produced from the second stage is significantly lower in dissolved constituents than required, the product water from the first stage may be blended with the second stage product to produce the desired water quality. When potable water and other waters with lower dissolved solids content are required, a product staging system can be used to supply the desired quality or qualities between that of the first and second stage product. Life cycle costing should be used to evaluate dual- and triple-distribution systems where product staging is required.

4.4.2 REJECT STAGING. Reject staging, Figure 4-4, is used when the low salinity of the raw water permits a high water-recovery ratio. Most membrane module manufacturers have a minimum allowable brine reject flow for any given membrane of their manufacture. The manufacturer's recommended maximum feed water flow rate and minimum recommended brine reject flow can be used to calculate a maximum recommended single stage recovery fraction by use of the following equation:

$$(F - B)/F = R$$

Where:

F = Maximum recommended feed flow per module

B = Minimum recommended brine reject flow per module

R = Maximum recommended recovery rate

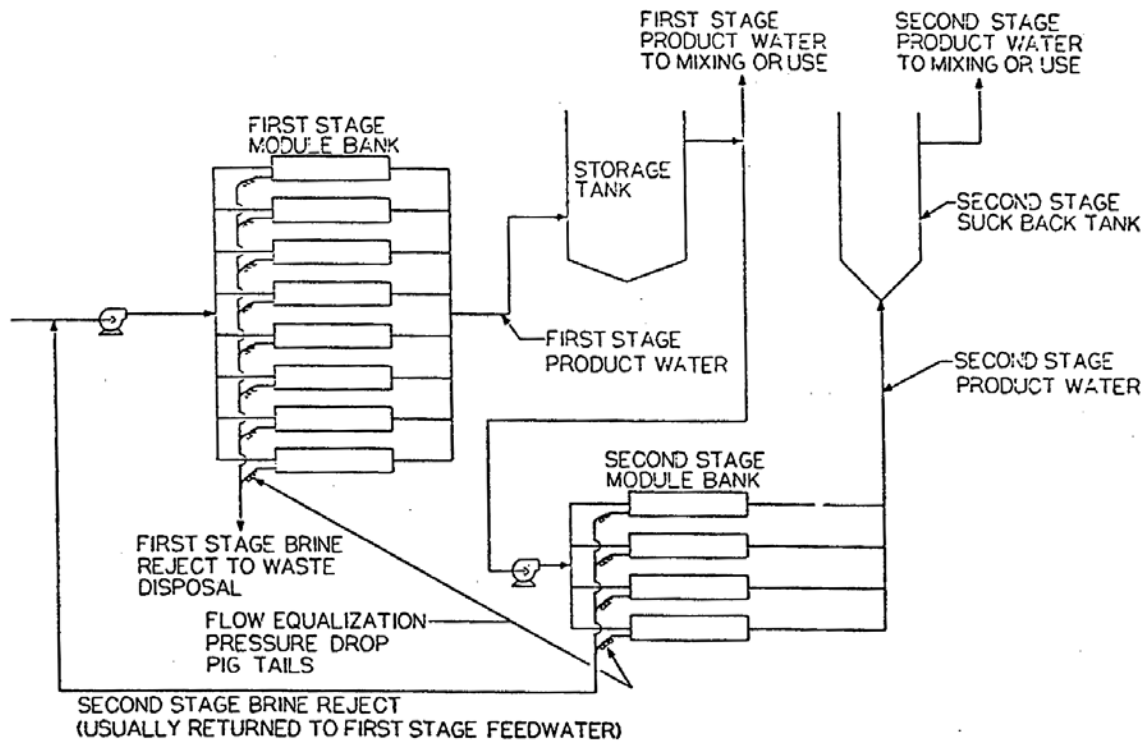

Figure 4-8

Reverse osmosis product staging

This maximum single stage water recovery is one means of evaluating a membrane module being considered for low salinity reverse osmosis desalination. When the reject stream is still diluted enough for further concentration after the maximum recommended recovery ratio is reached, the brine can be piped directly into another membrane module for further water recovery. This is accomplished by combining the brine flow from a number of first stage modules onto a fewer number of secondary membrane modules. It is occasionally possible to further concentrate the brine on a third reject stage as shown in Figure 4-9. The design of reject staging, in order to balance the utilization of the membrane modules for optimum economical life cycle cost, is a complex activity to be performed by the membrane manufacturer.

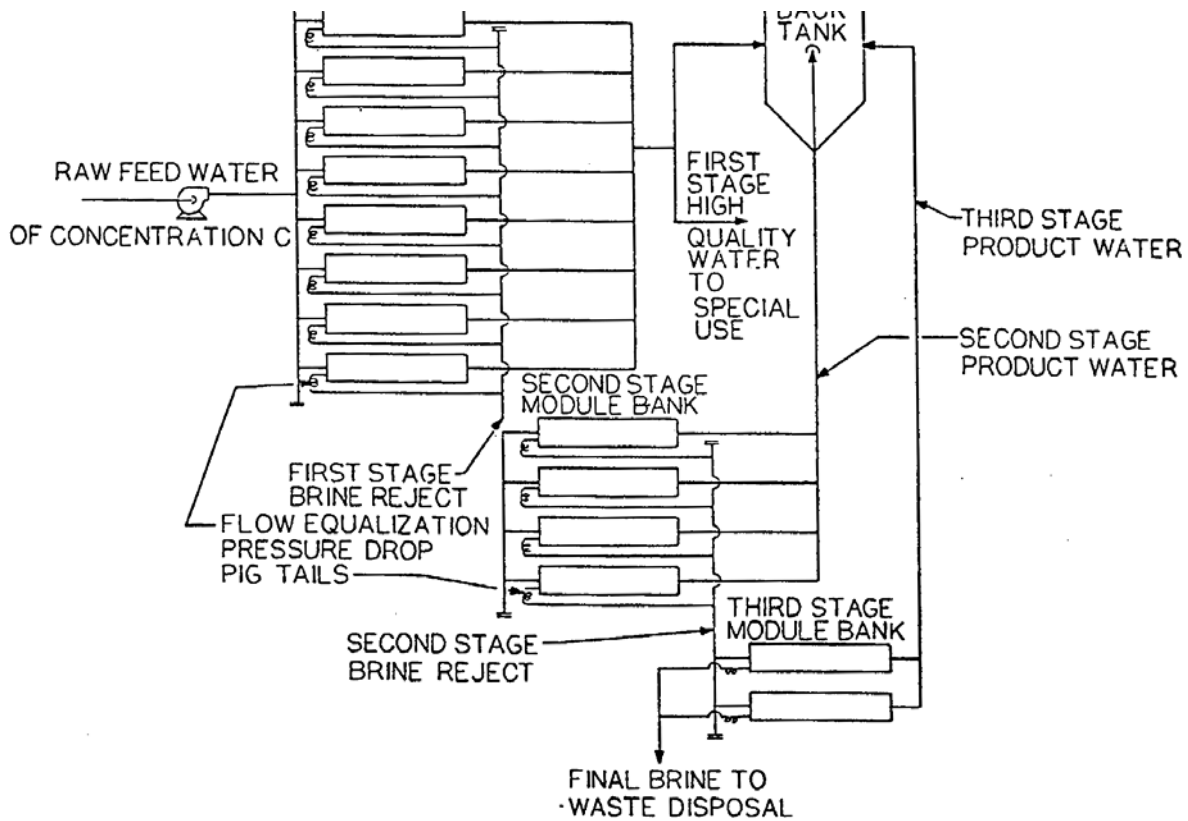

Figure 4-9

Reverse osmosis membrane reject staging

4.4.3 COMBINED PRODUCT AND REJECT STAGING. In the desalination of highly saline waters such as seawater, product and reject staging can be effectively combined. The second stage of a product staged system can be designed as a reject staged subsystem. Any of three factors may limit reverse osmosis water recovery: osmotic pressure; sparingly soluble salts; or turbidity. Water from a primary reverse osmosis treatment system will have three properties pertaining to these limitations:

- A lower osmotic pressure than the raw feed water.
- A disproportionately reduced concentration of divalent ions.
- No turbidity.

These qualities of primary reverse osmosis product water can allow for greater water recovery from a secondary product staged reverse osmosis subsystem than is allowed by the manufacturer's maximum recommended recovery rate. When the water recovery of the second stage of a product staged system can be increased by reject staging, the secondary stage shall be reject staged. When the brine from the secondary stage of a product staged system is less concentrated than the primary stage feed water by more than 1,000 milligrams of total dissolved solids per liter, the use of dedicated desalination of this lower concentration water shall be life cycle costed. This life cycle cost for dedicated secondary stage brine desalination shall be compared with the life cycle cost of blending the secondary stage brine into the primary stage feed water.

4.5 REVERSE OSMOSIS SYSTEM DESIGN. When process selection does not yield a specific membrane or even a particular process, then designs must be prepared for more than one process.

4.5.1 IDENTIFICATION OF WORK. When a schedule and a base site have been selected, this information will be made available to the design engineer. The identification of the location and the time schedule will be considered in the design; this includes the date the system must be online. The minimum number of independently operable membrane banks and the minimum capacity of the banks must be determined. Any restrictions that storage will place on maximum allowable downtime will also be determined. All reverse osmosis designs will consider a minimum membrane rejection for all objectionable materials in the pretreated saline water.

4.5.2 EXISTING OR PLANNED FACILITIES. Reverse osmosis design must include information on the available sources of mechanical energy. Electrical power is the most common energy source for conversion to mechanical pumping energy. The phase, voltage, frequency, and amperage of all available or planned electrical power will be determined. The process design, particularly with respect to pumping and pretreatment, must be detailed clearly.

4.5.3 RAW WATER INFORMATION. As with other desalination systems, one of two limitations exist on the quantity of raw water to be desalinated. Both of these limitations must be considered in the design:

- The maximum amount of waste brine that can be economically disposed of may place a limitation on the raw water used in the process.
- Availability of the raw water may limit the raw water used in the process.

The principle requirement in a reverse osmosis design is an accurate projection of the chemical, biological, and physical makeup of the poorest quality water that will ever be used as raw feed water at the site being investigated. The design documentation must include the following:

- Maximum total dissolved solids.
- Maximum concentration of every ion that could precipitate or influence the activity coefficient of a precipitation reaction.
- Maximum concentration of each ion that must be controlled in the product water.
- Concentration of both molybdate reactive and molybdate nonreactive silica.
- Maximum allowable concentration of non-ionizable material.
- An oil and grease analysis to levels below 10 milligrams per liter.
- Any gas or potential corrosive agent that may be in the feed water.

4.5.4 PROCESS DESIGN. When a particular membrane has been identified as the most economic, the design will be limited to the one membrane type. The process design for any reverse osmosis process will consider raw water quality and the required final product water quality. A suitable tank to meet suck-back requirements will be designed for all membranes that could be damaged by dehydration. The system design must be based on equipment with a history of successful water treatment experience. The required experience should include a minimum of 2 years of experience, treatment capacity, repair frequency and duration, and a ratio of repair cost to capital cost. The requirement for successful experience will limit the amount of untested innovation used at a facility. When a particular metallurgy or material is

required for strategic, corrosion design, or process economic reasons, this metallurgy will be included for all applicable parts, spare parts and equipment.

4.6 MATERIALS OF CONSTRUCTION. Ferric ions will cause severe problems in membrane systems. For this reason, never permit carbon steel to be in contact with the feed water being supplied to a membrane desalination plant. Use nylon or other plastics capable of maintaining the desired pressures whenever possible. Use 316L stainless steel for pump impellers and other feed-water-contact metal surfaces if hexametaphosphate is used for scale control. If no scale inhibition is necessary, use bronze for pump impellers.