

Sewer Design Guide

(Revised May, 2015)



City of San Diego
Public Utilities Department

PREFACE

The Sewer Design Guide is a guide for the engineer when planning and designing wastewater facilities and should be used for both public facilities and private facilities which serve multiple lots. This guide summarizes and outlines relevant City policies, applicable codes, and engineering and operational practices and procedures that have been developed in an effort to establish a cost-effective, reliable, and safe wastewater collection system. Also to be considered and used in conjunction with this design guide are all applicable current standard drawings, specifications, codes, laws and industry requirements for the planning and design of wastewater infrastructures.

This guide is not intended to be an instructional text and is not a substitute for professional experience, nor is it meant to relieve the design engineer from his/her responsibility to use good engineering judgment. The design engineer shall be responsible for providing a design that, within industry standards, can be safely repaired and maintained, will provide good service and life, and will not create a public nuisance or hazard. Under most conditions, this guide should serve as a minimum standard. However, it is not meant to preclude alternative designs when the standards cannot be met, or when special or emergency conditions warrant, as long as proper authorization is obtained.

The Public Utilities Department encourages “partnering”, the creation of an open working relationship between staff in each section/department and our customers, to promote achievement of mutual and beneficial goals. All projects can benefit when common goals and interests are identified, lines of communication are established and open, and there is a commitment from all parties to solve problems collaboratively.

We would like to continue to make positive changes to this document as standards, technology, and materials change. Please submit to your Senior Civil Engineer, in writing, any changes you think warrant consideration.

Many people have endeavored to make this document useful and representative of good engineering and maintenance practices. The Public Utilities Department would like to acknowledge and thank the individuals who have invested considerable effort in establishing and improving the Sewer Design Guide.

Roger S. Bailey
Director of Public Utilities

SPECIAL ACKNOWLEDGMENTS

The Committee recognizes the contribution by the following individuals in the revision, preparation, and editing of the 2013 Sewer Design Guide.

Rania Amen	Paul Buehler
Berric Doringo	Ernesto Fernandez
Dave Grossman	Isam Hireish
Cha Moua	Huy Nguyen
Stephanie Pang	Tung Phung
Nabeel Qawasmi	Margaret Quach
Bobbi Salvini	Jamal Shamoon
Richard VanderSchaff	

SEWER DESIGN GUIDE
TABLE OF CONTENTS

		<u>Page</u>
INTRODUCTION		1
CHAPTER 1 SEWER SYSTEM PLANNING		1-1
1.1	GENERAL	1-1
1.2	PRELIMINARY PROJECT PLANNING	1-1
	Alignment and Grade of Mains	1-1
	New Mains.....	1-1
	Relocated Mains	1-2
	Precedence of Sewer Facilities	1-2
	Private Mains	1-2
	Easements for Mains.....	1-3
	Pump Station Location	1-3
	Sewers in Canyons and Environmentally Sensitive Lands	1-3
1.3	PLANNING STUDY	1-4
	General Requirements	1-4
	Capacity	1-5
	Drainage Basin.....	1-5
	Depth of Mains	1-6
	Existing Studies	1-6
	Flow Estimation	1-6
	Land Use	1-6
	Flow Determination	1-6
	Pipe Sizing Criteria	1-8
	Hydraulic Requirements	1-8
	Slope	1-9
	Ratio of Depth of Flow to Pipe Diameter (d_w/D)	1-9
	Minimum Pipe Sizes.....	1-9
	Sewer Study Exhibit Criteria.....	1-9
	Private On-Site Wastewater Treatment and Reuse.....	1-9
1.4	SEPARATION OF MAINS	1-9
	Horizontal Separation.....	1-9
	Wet Utilities.....	1-9
	Separation for Dry Utility Pipes and Cable Conduits	1-10
	Vertical Separation.....	1-10
	Shallow Mains, General.....	1-10
	Parallel Mains	1-10
	Crossing Mains	1-11
1.5	PUMP STATION PLANNING CRITERIA	1-11
	Pump Station Design Capacity.....	1-11
	Private Pump Stations	1-12
1.6	ZONE-DENSITY CONVERSIONS	1-12
1.7	REQUIRED CAPACITY IN EXISTING SEWER SYSTEMS DOWNSTREAM OF NEW FACILITIES.....	1-13

	Required Capacity Downstream of New Gravity Sewers	1-13
	Required Capacity Downstream of New Pump Stations.....	1-13
	Odor Control.....	1-14
1.8	MINIMUM INTAKE STANDARDS FOR SEWER STUDIES	1-14
CHAPTER 2	GRAVITY SEWER SYSTEM DESIGN	2-1
2.1	GENERAL	2-1
2.2	DESIGN OF SEWER MAINS.....	2-1
	General Considerations	2-1
	Determination of Allowable Loading.....	2-1
	Design Deflection of PVC Pipes	2-1
	Traffic Loads, Dead Loads, and Other Loads	2-2
	Concrete Encasement/Casing	2-2
	Depth of Mains.....	2-2
	Shallow Mains.....	2-3
	Depth of Dead-End Mains.....	2-3
	Redundant Sewers	2-3
	Sewer Mains 15 Inches and Smaller in Diameter.....	2-4
	Minimum Depths.....	2-4
	Changes in Direction.....	2-4
	Requirements for Depths Greater Than 15 Feet.....	2-4
	Sewer Mains 18 Inches and Larger in Diameter (Trunk Sewers)	2-4
	Changes in Direction.....	2-4
	Allowable Loading	2-5
	Shop Drawing/Material Submittal Requirements	2-5
	Trench Details	2-5
	Hydraulic Jumps.....	2-5
	Alignment of Sewers	2-6
	Utility Crossings.....	2-7
	Profile of Sewers	2-8
	Cutoff Walls	2-8
	Curvatures	2-9
	Curvature in Rigid Pipes	2-9
	Curvature in Flexible Pipes	2-10
	Horizontal Curvature.....	2-10
	Vertical Curvature	2-11
	Prohibited Locations.....	2-11
	Main Extensions.....	2-12
2.3	MANHOLES.....	2-12
	General Design Considerations	2-12
	Required Locations.....	2-12
	Prohibited Locations.....	2-12
	Manholes at Street Intersections.....	2-13
	Manholes Outside Public Right-of-Way	2-13
	Potential Hydraulic Jumps.....	2-13
	Cul-De-Sac and Dead End Mains.....	2-13
	Distance Between Manholes	2-14
	Design of Manhole Shelves	2-14
	Manhole Frames and Covers	2-15

	Manhole Lining and Grouting	2-15
	Bases.....	2-15
	Riser Joints	2-15
	Risers.....	2-16
	Exterior Walls.....	2-16
	Minimum Invert Drop Across a Manhole	2-16
	Manholes with the Same Inlet and Outlet Diameter.....	2-16
	Outlet Pipe Larger Than Inlet.....	2-17
	Maximum Invert Drops Across Manhole.....	2-18
	Minimum Manhole Size.....	2-18
	Large Diameter Manholes	2-18
	Deep Manholes.....	2-18
	Inspection of Existing Manholes	2-19
	Raising Manhole Covers	2-19
2.4	PIPE BEDDING.....	2-19
	Normal Bedding Requirements	2-19
	Special Considerations	2-19
	Load Factors for Clay Pipe.....	2-19
2.5	SEWER LATERALS	2-20
	Allowable Locations.....	2-20
	Depth Requirements	2-20
	Slope.....	2-21
	Cleanouts	2-21
	Bedding	2-21
	Backwater Devices	2-21
	Pressure Laterals.....	2-22
	Connections to Existing Mains.....	2-22
	Required Location of Connections.....	2-22
	Allowable Types of Connections	2-23
	Size of Connections.....	2-23
	Required Rise From Main	2-23
	Connections to Trunk Sewers.....	2-23
	Common Laterals	2-24
	Easement Laterals.....	2-24
	Main Extension Waiver.....	2-24
	Single Family Residence	2-25
	Standard Deviation Category	2-25
	Cul-De-Sac Deviation Category.....	2-25
	Multi-Family Residential and Commercial Units	2-25
	Encroachment Maintenance and Removal Agreement (EMRA)	2-25
	Laterals Crossing Lot Lines	2-26
	Lateral Abandonment	2-26
	CIP Construction	2-26
2.6	REHABILITATION	2-27
	Pipeline Rehabilitation	2-27
	Manhole Rehabilitation	2-27
	Lateral Rehabilitation.....	2-28

2.7	WASTEWATER IMPROVEMENT PLANS - STANDARDS AND PROCEDURES	2-28
	General	2-28
	Improvement Plan Requirements	2-28
	Pipelines	2-29
	Special Facilities.....	2-29
	Standard Specifications and Drawings	2-30
	Notes on Improvement Plans	2-30
	Legend Items	2-33
	Data Tables.....	2-34
	Sewer Main Abandonment.....	2-34
	Sewer Data Table	2-34
	Sewer Lateral Table.....	2-34
2.8	PLANNING AND DESIGN SUBMITTAL REQUIREMENTS.....	2-35
	General	2-35
	Sewer Study.....	2-35
	Public Easements.....	2-35
	Encroachment Maintenance and Removal Agreement (EMRA)	2-35
	Covenants, Conditions, and Restrictions (CC&R)	2-35
	Minimum Plan Sets	2-35
	Sewer Maintenance Plan	2-36
2.9	CONSTRUCTION PLAN MINIMUM INTAKE CHECK LIST - QUALITY ASSURANCE/QUALITY CONTROL.....	2-36
2.10	SPECIAL FACILITIES PLAN CHECK.....	2-36
CHAPTER 3 EASEMENTS AND ENCROACHMENTS.....		3-1
3.1	GENERAL	3-1
3.2	EASEMENT REQUIREMENTS.....	3-1
	Location of Easements	3-1
	Preferred Location	3-1
	Easements Within Lots	3-2
	Non-Contiguous Sewer Easement Roads	3-2
	Fenced Easements.....	3-2
	Easement Width	3-2
	Minimum Width-Sewer Depths Less than 10 Feet.....	3-2
	Sewer Depths Greater Than 10 Feet	3-3
	Structures Adjacent to Easement	3-3
	Multiple Use Easements	3-3
	Easements in Open Space Areas.....	3-3
	Easements in Dedicated Parklands	3-3
	Easements in Commercial/Business Property and/or Private Streets	3-4
	Easements Adjacent to Slopes, Buildings, or Retaining Walls.....	3-4
	Easements in Areas with Special Soil or Geotechnical Concerns	3-4
	Easement Width Rounding	3-5
	Access Facility Requirements	3-7
	Standard Sewer Access Roads.....	3-7
	Access Roads in Residential Side Yards	3-7
	Access Roads in Dedicated Parks	3-8

	Access Facilities in Environmentally Sensitive Lands	3-8
	Location of Utilities within an Easement	3-9
	General	3-9
	Additional Utilities	3-10
	Sewer Laterals in a Private Street Easement.....	3-10
	Private Easements	3-10
3.3	ENCROACHMENTS	3-10
	General	3-10
	Structures in Easements.....	3-10
	Other Encroachments	3-11
	General Landscape.....	3-11
	Threatened or Endangered Plants	3-11
	Landscape for Access Paths in Environmentally Sensitive Areas	3-11
	Encroachment, Maintenance and Removal Agreement (EMRA).....	3-12
3.4	EASEMENT RESEARCH.....	3-12
	Easements Granted by Subdivision or Parcel Map	3-12
	Easements by Grant Deed	3-12
	Search by the City Clerk.....	3-13
	Improvement Plan Inspection for Easements.....	3-13
	Search at the County Recorder	3-13
CHAPTER 4 SEWER MAIN BRIDGE CROSSING DESIGN		4-1
4.1	GENERAL	4-1
4.2	PERMITS	4-1
	City	4-1
	CALTRANS	4-1
4.3	PIPELINE CONSTRUCTION.....	4-1
	General Design.....	4-1
	Design Considerations	4-1
	Standard of Design.....	4-2
	Pipeline Requirements	4-2
	Future Expansion	4-2
	Spare Pipe in Closed Cell Bridges	4-2
	Gravity Main Manhole Requirements	4-2
	Force Main Isolation.....	4-2
	Access Vaults and Sleeves.....	4-3
	Pipeline Location.....	4-3
	Access Requirements	4-3
	Loading Considerations.....	4-4
4.4	PIPELINE MATERIALS.....	4-4
	Pipe Requirements.....	4-4
	Ductile Iron Pipe.....	4-4
	Pipeline Casing.....	4-5
	Available Joint Types and Characteristics	4-5
	Flanged Connection	4-5
	Push-on Joint.....	4-5
	Mechanical Joint	4-5
	Restrained Push-on Joint	4-5
	Ball and Socket Joint	4-6
	Joint Application Considerations	4-6
	Joints for Ductile Iron Pipe	4-6

	Expansion Joints	4-6
	Joints at Transitions	4-6
	Cathodic Protection	4-7
4.5	SUPPORTS	4-7
4.6	OTHER DESIGN CONSIDERATIONS	4-7
CHAPTER 5 ABANDONMENT OF EXISTING SEWER MAINS, MANHOLES AND EASEMENTS		
	5-1	
5.1	GENERAL	5-1
5.2	ABANDONMENT OF SEWER FACILITIES	5-1
5.3	ABANDONMENT OF SEWER EASEMENTS.....	5-2
CHAPTER 6 CORROSION CONTROL		
6.1	GENERAL	6-1
6.2	MATERIAL SELECTIONS AND CONSIDERATIONS	6-1
	Concrete	6-1
	Steel.....	6-2
	Ductile Iron.....	6-2
	Aluminum.....	6-3
	Copper and Brass.....	6-3
	Stainless Steel.....	6-3
	Polyvinyl Chloride	6-3
	Fiberglass	6-4
	Vitrified Clay Pipe.....	6-4
6.3	PRE-DESIGN SURVEYS	6-7
	Soil Resistivity Testing	6-7
	Laboratory Soil Testing.....	6-8
	Identification of Potential Stray Current Sources.....	6-9
	Stray Currents.....	6-9
6.4	CORROSION MONITORING AND CATHODIC PROTECTION DESIGN.....	6-10
	Electrical Continuity.....	6-10
	Electrical Isolation.....	6-10
	Test Stations	6-10
6.5	COATINGS AND LININGS	6-11
6.6	CATHODIC PROTECTION	6-11
6.7	SEWER PUMP STATIONS AND FORCE MAINS	6-12
	Sewer Pump Station Piping Coatings.....	6-12
	Force Main Linings and Coatings	6-12
	Valve Coatings	6-13
	Pump Interior Lining	6-13
	Wet Well & Emergency Storage Tank Lining	6-13
CHAPTER 7 SEWER PUMP STATION DESIGN CRITERIA AND EQUIPMENT DESIGN GUIDELINES		
	7.1-1	
7.1	GENERAL REQUIREMENTS FOR DESIGN ENGINEERS	7.1-1
	Implementation of Design Guide Requirements	7.1-1
	Energy Efficient Designs.....	7.1-1
	Documentation of Implementation of Design Guide Requirements	7.1-1
	Written Responses to Design Review Comments	7.1-1

	“Special Station Requirements”	7.1-2
	Project Meetings with the City	7.1-2
	Requirements for Design Documents.....	7.1-2
	Private Sewer Pump Stations	7.1-3
7.2	SUMMARY OF FACILITY CAPACITY AND HYDRAULIC	
	DESIGN CRITERIA	7.2-1
7.2.1	PURPOSE	7.2-1
7.2.2	DESIGN CAPACITY CALCULATIONS	7.2-1
	Pump Station Design Capacity Calculation	7.2-1
7.2.3	PUMP AND SYSTEM CALCULATIONS	7.2-1
	Constant Versus Variable Speed Pumps	7.2-1
	Variable Speed Pumps: (Special Station Requirement)	7.2-1
	Uniform Sizing and Number of Service and Standby Pumps	7.2-1
	Calculation of Hydraulic Losses	7.2-2
	Allowable Pipe Velocities	7.2-2
	NPSHA Calculation	7.2-2
	Pump and System Curves.....	7.2-2
	Calculation of System Curves.....	7.2-3
	Selection of Candidate Manufacture’s Pump Curves	7.2-3
	“Flat” Pump Curves	7.2-3
	Plotted System and Pump Curve Information on Design Drawings.....	7.2-3
	Multiple Pump Operation Curves	7.2-3
	Other Information and Pump Curves.....	7.2-3
	Pump Selection.....	7.2-3
	Design Pump Rating and Requirements.....	7.2-4
	Impeller Information for Plotted System and Pump Curves	7.2-4
	Specification of Design Pumps	7.2-5
7.2.4	MASS ELASTIC SYSTEMS AND CRITICAL SPEED CALCULATIONS	7.2-5
7.2.5	SURGE PRESSURE CALCULATIONS	7.2-5
	Surge Analysis Methodology	7.2-5
	Submittal of Hydraulic Transient Memorandum.....	7.2-6
	Transient Control Measures	7.2-6
	Shaft-Mounted Flywheels.....	7.2-6
	Force Main Alignment	7.2-6
	Vacuum Relief Valves and Pressure Release Valves (Combination Type).....	7.2-6
	Slow Closing, Hydraulically-Operated Pump Discharge Valves.....	7.2-6
	Vacuum Relief Valves or Check Valves (Vented from Wet Well)	7.2-6
	Non-Approved Measures	7.2-6
7.2.6	WET WELL CALCULATIONS	7.2-7
	Flow Data Table	7.2-7
	Wet Well Inlet	7.2-7
	Wet Well Operating Volume.....	7.2-7
	Minimum Inflow Calculation.....	7.2-7
	First Pump Call Level in the Wet Well Operating Volume	7.2-8
	Wet Well Operating and Alarm Levels	7.2-8
	Emergency Storage Volume.....	7.2-9
	Influent Line Storage.....	7.2-9
	Spill Location Indication	7.2-9
7.2.7	SIX-HOUR EMERGENCY STORAGE (SPECIAL STATION	

	REQUIREMENT).....	7.2-9
	Closed Tanks	7.2-9
	Ponds	7.2-10
7.2.8	FORCE MAIN	7.2-10
	Capacity of Discharge Sewer	7.2-10
	Maximum Force Main Retention Time.....	7.2-10
7.3	PUMPS.....	7.3-1
7.3.1	VERTICAL NON-CLOG PUMPS	7.3-1
	Standard Design	7.3-1
	General Construction.....	7.3-1
	Maximum Size Solid Passing Through Impeller.....	7.3-1
	Mechanical Seals.....	7.3-1
	Pump Pressure Gauge Installation.....	7.3-1
	Pump Bases	7.3-1
	Stainless Steel Anchor Bolts for Pump Bases	7.3-2
	Pump Drain Lines.....	7.3-2
7.3.2	MOTORS	7.3-2
	Motors for Extended Shaft Pumps	7.3-2
	Motor Horsepower Selection.....	7.3-2
	Motor Features	7.3-2
	Soft Start Motor Starters.....	7.3-3
7.3.3	EXTENDED DRIVE SHAFTS.....	7.3-3
	General	7.3-3
	U-Joint Greasing Access	7.3-3
	Safety Guard.....	7.3-3
	Intermediate Level Motors (Special Station Requirement).....	7.3-3
7.3.4	EQUIPMENT CLEARANCES	7.3-3
	Minimum Equipment Clearances	7.3-3
7.3.5	SPARE PARTS TO BE FURNISHED	7.3-4
7.3.6	LARGE PUMP STATIONS (SPECIAL STATION REQUIREMENT)	7.3-4
	Classification	7.3-4
	Mechanical Seals for Variable Speed Pumps (Special Station Requirement).....	7.3-4
	Split Mechanical Seals (Special Station Requirement)	7.3-4
	Air Gap Seal Water Pressurization System (Special Station Requirement).....	7.3-4
	Air Gap Tank Installation (Special Station Requirement).....	7.3-5
7.3.7	PUMP STATION EQUIPMENT RETROFIT PROJECTS (SPECIAL STATION REQUIREMENT).....	7.3-5
	Retrofitting Equipment in Existing Pump Stations.....	7.3-5
	Close Coupled Motors (Special Station Requirement)	7.3-5
	Dry Pit Submersible Pump Installation (Special Station Requirement)	7.3-5
	Wet Well Submersible Pump Installation (Special Station Requirement).....	7.3-6
7.4	PIPING AND APPURTENANCES.....	7.4-1
7.4.1	ISOLATION VALVES.....	7.4-1
	Dry Well Isolation Valves	7.4-1
	Valve Operators.....	7.4-1
	Valve Accessibility.....	7.4-1
	Elevated Valve Access	7.4-1
	Suction Valve Extensions.....	7.4-1
	Buried Valves.....	7.4-1

	Wet Well Isolation Valve	7.4-1
	Underground Valves in Vaults (Special Station Requirement)	7.4-2
7.4.2	CHECK VALVES	7.4-2
	General Features - Rubber Flapper Check Valves	7.4-2
	Specific Valve Features	7.4-2
	Surge Control Check (Special Station Requirement)	7.4-2
	Proximity Switch	7.4-2
7.4.3	PIPING AND FITTINGS	7.4-3
	Ductile Iron	7.4-3
	Threaded-on Ductile Iron Flanges	7.4-3
	Make-Up Length Piping	7.4-3
	Pipe Disassembly Lengths	7.4-3
	Approved Pipe Joints	7.4-3
	Non-Approved Coupling Fittings	7.4-3
	Victaulic Couplings (Special Station Requirement)	7.4-3
	Restrained Couplings for Ease of Piping Alignment	7.4-3
	Piping Supports and Bracing	7.4-3
	Seismic Zone 4 Design	7.4-3
	Base Elbows	7.4-4
	Manifold Configuration	7.4-4
	Manifold to Force Main(s) Piping Configuration	7.4-4
7.4.4	FORCE MAIN DRAIN LINES	7.4-4
	Force Main Drain Lines to Wet Well	7.4-4
	Force Main Drain Lines (Special Station Requirement)	7.4-4
7.4.5	SMALL APPURTENANCE PIPE FITTINGS	7.4-4
	Small Appurtenance Piping	7.4-4
7.4.6	STAINLESS STEEL BOLTING	7.4-5
	Dry Well Fasteners	7.4-5
	Wet Well and Buried Fittings Fasteners	7.4-5
7.4.7	AIR RELEASE VALVES	7.4-5
	Installation Locations	7.4-5
	Flooded Suction Pumps	7.4-5
	Air Release Valves	7.4-5
	Stainless Steel Pipe Fittings	7.4-5
	Air Valve Drain Piping	7.4-5
	Self-Priming Pumps (Special Station Requirement)	7.4-5
	Submersible Pumps (Special Station Requirement)	7.4-6
7.4.8	SCHEDULE OF PIPE MATERIALS	7.4-6
	Schedule on Mechanical Drawings	7.4-6
7.5	ELECTRICAL, CONTROLS, AND INSTRUMENTATION	7.5-1
7.5.1	GENERAL	7.5-1
7.5.2	POWER SWITCHGEAR AND DISTRIBUTION	7.5-1
	Lockout Safety	7.5-1
	Circuit Breakers	7.5-1
	Switchgear Rating Coordination	7.5-1
	Line Power Monitoring	7.5-2
	Ground Fault Protection	7.5-2
	Grounding System	7.5-2
	Motor Starter Design	7.5-2

	Motor Control Center Switchgear Equipment.....	7.5-3
	Wiring and Bus Bars	7.5-3
	Seismic Braces	7.5-3
	House Service Panel.....	7.5-4
	Electrical Conduit.....	7.5-4
	Conduit Routing Schedule:	7.5-4
	Electrical Outlets	7.5-4
7.5.3	INSTRUMENTATION AND CONTROLS	7.5-5
	General	7.5-5
	Dedicated Gas Monitoring	7.5-5
	Flow Meter	7.5-5
	Level Control.....	7.5-5
	Pump Control and Alarm Circuit "Ladder Logic" Diagrams	7.5-6
	Pump Control Description.....	7.5-6
	Calibration Schedule	7.5-6
	Process Instrumentation and Control Diagram.....	7.5-6
	"Fail-Safe" Design Alarm Relays.....	7.5-6
	Emergency Motor Controls	7.5-7
	Motor Starter Circuit Hand Operation.....	7.5-7
	Emergency Stop	7.5-7
	Pump Status Indicator Lights	7.5-7
	Pump Run Time.....	7.5-7
	Telemetry Alarms.....	7.5-8
	Station Status and Alarm Condition Enunciator Panel.....	7.5-8
	Panel Indicator Light Bulbs.....	7.5-8
	Alarm and Control Relay Resets	7.5-8
7.5.4	TELEMETRY	7.5-8
7.5.5	ALTERNATE BACKUP POWER	7.5-8
	Emergency Backup Power	7.5-8
	Emergency Power Plant Fuel	7.5-10
	Fuel - Diesel (Special Station Requirement)	7.5-10
	Transfer Switch—Automatic	7.5-11
	Transfer Switch—Manual (Special Station Requirement).....	7.5-11
	Emergency Generator Installation Location.....	7.5-12
	Emergency Plug-In Connection	7.5-12
7.5.6	OTHER STATION REQUIREMENTS	7.5-13
	Emergency Lighting.....	7.5-13
	Corrosion Control System (Special Station Requirement).....	7.5-13
7.6	VENTILATION	7.6-1
7.6.1	GENERAL REQUIREMENTS	7.6-1
	Dry Well Required Air Changes	7.6-1
	Air Supply/Exhaust Locations.....	7.6-1
	Ductwork Materials	7.6-1
	Maintenance Access Covers.....	7.6-1
	Location of Fan Installations	7.6-1
	Ventilation Filters (Special Station Requirement)	7.6-1
	Rodent Proofing Openings	7.6-1
7.6.2	AVOIDING VENTILATION CROSS CIRCUITING	7.6-1
	Ventilation Short-Circuiting Considerations	7.6-1

7.6.3	NOISE ATTENUATION.....	7.6-2
	Maximum Allowable Noise Levels at Property Line.....	7.6-2
	Maximum Allowable Noise Levels Inside Station.....	7.6-2
7.6.4	GENERATOR ROOM VENTILATION.....	7.6-2
	Required Continuous Generator Room Ventilation.....	7.6-2
	Ventilation During Generator Operation.....	7.6-2
7.6.5	VENTILATION/ODOR CONTROL OF THE WET WELL.....	7.6-2
	Odor Control System.....	7.6-2
	Power Ventilation/Odor Control (Special Station Requirement).....	7.6-3
7.6.6	DEHUMIDIFIER.....	7.6-3
	Dehumidifier Installation (Special Station Requirement).....	7.6-3
7.6.7	AIR CONDITIONING/COOLING SYSTEMS.....	7.6-3
	Electrical Rooms (Special Station Requirement).....	7.6-3
	Panel Cooling: (Special Station Requirement).....	7.6-4
7.7	DRY WELL.....	7.7-1
7.7.1	GENERAL REQUIREMENTS.....	7.7-1
	Above Grade Building Construction.....	7.7-1
	Stairway Access.....	7.7-1
	Underground Station Access Stairs.....	7.7-1
	Underground Station Equipment Hatches.....	7.7-1
	Personnel Access to Equipment-Elevated Platforms.....	7.7-1
	Rolling Stairway for Equipment Access (Special Station Requirement).....	7.7-1
	Fire Extinguishers.....	7.7-2
	Fire Rated Doors.....	7.7-2
	Fluorescent Lights.....	7.7-2
	Safety Lighting.....	7.7-2
	Skylights (Special Station Requirement).....	7.7-2
	Safety Warning Signs.....	7.7-2
	Concrete Surface Sealing.....	7.7-2
	Non-Skid Coating.....	7.7-2
	Equipment Maintenance Clearance.....	7.7-2
	Safety Guards.....	7.7-2
	Valve Wrenches.....	7.7-3
	Hose Bib.....	7.7-3
7.7.2	EQUIPMENT REMOVAL.....	7.7-3
	Hoist Clearance.....	7.7-3
	Extended Shaft Pump Equipment Hoisting.....	7.7-3
	Hoisting Submersible Pumps (Special Station Requirement).....	7.7-3
	Traveling Overhead Crane Rail Hoists.....	7.7-4
	Equipment Hatches.....	7.7-4
7.7.3	HAZARDOUS GAS DETECTION SENSORS.....	7.7-4
	Methane/Explosive Gas Sensors and Alarms.....	7.7-4
	Access to Sensors.....	7.7-4
	Hazardous Gas Warning Sign.....	7.7-4
7.7.4	FINISHES AND STANDARDIZED PAINT SCHEMES AND LETTERING.....	7.7-4
	Piping Color Scheme and Markers.....	7.7-4
	Paint Scheme for Other Equipment.....	7.7-5
7.7.5	SUMP PUMPS.....	7.7-6

	Piping to Sump Pump.....	7.7-6
	Sump Pump Features.....	7.7-6
	Sump Pump Discharge Piping Features	7.7-7
7.7.6	FLOODED MCC LEVEL ALARM AND SWITCH	7.7-7
	Electrical Power Shutoff on Major Flooding	7.7-7
7.8	WET WELL	7.8-1
7.8.1	INLET DESIGN.....	7.8-1
	Inlet Pipe	7.8-1
	Inlet Sewer.....	7.8-1
	Influent Flow Meter (Special Station Requirement)	7.8-1
	Spill Location	7.8-1
7.8.2	HYDRAULIC DESIGN.....	7.8-1
	Standard Wet Well Configuration.....	7.8-1
	Suction Elbow	7.8-2
	Self-Cleaning Wet Wells (Special Station Requirement).....	7.8-2
7.8.3	TRASH RACK.....	7.8-2
	Trash Rack Above Pump Suction.....	7.8-2
	Large Pump Station Track Rack/Screen (Special Station Requirement)	7.8-2
	Self-Cleaning Wet Wells (Special Station Requirement).....	7.8-3
	Mechanical Screens: (Special Station Requirement).....	7.8-3
7.8.4	STORAGE VOLUME REQUIREMENTS	7.8-3
	Operational, Two-Hour, and Six-Hour Emergency Storage Volume Requirements	7.8-3
	Design Features for Emergency Overflow Storage Wet Well	7.8-3
	Design Features for Emergency Overflow Storage Tank.....	7.8-3
	Passive Overflow.....	7.8-4
7.8.5	CORROSION PROTECTION	7.8-4
	T-Lock Lining	7.8-4
	Pipe and Fittings Coatings and Linings.....	7.8-4
	Fasteners.....	7.8-4
7.8.6	ELECTRICAL EQUIPMENT INSTALLATION	7.8-4
	Level Control.....	7.8-4
	Explosion Proof Installation	7.8-4
7.8.7	WET WELL VENTILATION AND ODOR CONTROL.....	7.8-4
	Ventilation, Odor Control.....	7.8-4
7.8.8	WET WELL ACCESS	7.8-5
	Standard Access	7.8-5
	Alfalpa Valves (Special Station Requirement)	7.8-5
7.9	FORCE MAINS	7.9-1
7.9.1	GENERAL REQUIREMENTS.....	7.9-1
	Force Main Velocity	7.9-1
	Dual Force Mains	7.9-1
	PVC Pressure Pipe.....	7.9-1
	Ductile Iron Pipe (Special Station Requirement)	7.9-1
	Force Main Isolation Valves	7.9-1
	Flex Couplings at Pump Station Wall	7.9-1
	Cathodic Protection	7.9-1
	Thrust Blocks	7.9-2
	Restrained Buried Pipe Joints.....	7.9-2

	Cut-Off Walls	7.9-2
	Use of 45 Degree Elbow Fittings	7.9-2
	Force Main Drains (Special Station Requirement)	7.9-2
	Force Main Separation and Pipe Joint Stagger.....	7.9-2
	Use of Combination Air Valves	7.9-2
7.9.2	ISOLATION VALVES AND EMERGENCY PUMPING CONNECTION	7.9-3
	Solid Wedge Type Valves.....	7.9-3
	Isolation Valve Location	7.9-3
	Force Main Drain Lines	7.9-3
	Emergency Pumping Connections	7.9-3
	Valving Diagram	7.9-3
7.9.3	DISCHARGE MANHOLE	7.9-3
	Discharge Manhole.....	7.9-3
7.9.4	ODOR CONTROL	7.9-4
	Chemical Odor Control	7.9-4
7.10	STATION BUILDINGS AND SITE REQUIREMENTS	7.10-1
7.10.1	STRUCTURAL CONCRETE	7.10-1
	Reinforced Concrete.....	7.10-1
	Structure Waterproofing and Moisture Barriers.....	7.10-1
	Wall Penetrations	7.10-1
	Concrete Form Taper Ties.....	7.10-1
	Waterstops	7.10-1
	Prohibition of Package Plant Type Facilities	7.10-1
	Floor Penetrations	7.10-1
7.10.2	BUILDING CONSTRUCTION	7.10-2
	Typical Construction	7.10-2
7.10.3	BUILDING FEATURES	7.10-2
	Intrusion Security	7.10-2
	Outside Door Fittings and Locks.....	7.10-2
	Bulletin Board and Reference Shelf	7.10-2
	Building Lighting	7.10-2
	Site Lighting	7.10-2
7.10.4	SITE, ACCESS, AND PAVING	7.10-2
	Fee Title Property	7.10-2
	Site Paving.....	7.10-2
	Site Fencing and Walls.....	7.10-3
	Gates.....	7.10-3
	Positioning Maintenance Vehicles	7.10-3
	Vehicle Turnaround Radius.....	7.10-3
	Parking over Wet Well Pipe Connections	7.10-3
	Flood Plain Elevation	7.10-3
7.10.5	WATER METER AND BACKFLOW PROTECTION	7.10-3
	Water Meter Costs and Backflow Protection Device	7.10-3
	Water Meter Ownership	7.10-3
	Hose Bib and Backflow Protection	7.10-4
	Emergency Eyewash (Special Station Requirement)	7.10-4
	Restroom (Special Station Requirement)	7.10-4
7.10.6	LANDSCAPING	7.10-4

	City Standard.....	7.10-4
	Xeriscaping.....	7.10-4
	Backflow Protection on Irrigation Piping.....	7.10-4
7.11	CONSTRUCTION MANAGEMENT AND OPERATIONAL TESTING SPECIFICATIONS.....	7.11-1
7.11.1	GENERAL	7.11-1
7.11.2	COORDINATION OF NEW CONSTRUCTION WITH EXISTING STATION OPERATION	7.11-1
	Salvage Note on Drawings	7.11-1
	Temporary Bypass Pumping (Special Station Requirement).....	7.11-1
	Sequence of Construction.....	7.11-1
7.11.3	FACILITY TESTING	7.11-1
	General Requirements	7.11-1
	Design Engineer Responsibilities	7.11-1
	Contractor Responsibilities	7.11-2
	“Master Test Plan”.....	7.11-2
	Contractor Test Coordinator	7.11-2
	Scheduling of Facility Tests	7.11-2
	Testing Costs.....	7.11-2
	Coordination with Other Specification Sections.....	7.11-2
	Summary of Master Test Plan	7.11-2
	Factory Testing	7.11-3
	Functional Checkouts and Installation Certification.....	7.11-3
	Pre-Operational and Start-Up Testing	7.11-3
	HVAC Testing	7.11-3
	Operational Test.....	7.11-3
	Commissioning	7.11-4
7.11.4	OPERATIONS AND MAINTENANCE MANUAL.....	7.11-4
	Number of Copies	7.11-4
	Warranty Address.....	7.11-4
	O&M Contents	7.11-4
	Consolidated Summary	7.11-4
	Automatic Controls Summary	7.11-4
	As-Built Drawings of Electrical/Controls.....	7.11-4
	Manufacturers’ Certificates	7.11-4
	Equipment Specifications and Detailed O & M Information.....	7.11-4
	Warranty forms	7.11-5
	Table of contents.....	7.11-5
	Certified Pump Test Curves.....	7.11-5
7.11.5	FACILITY ACCEPTANCE BY THE CITY	7.11-5
	Recommendation for Acceptance by Owner.....	7.11-5
	Acceptance of Operational Responsibility	7.11-5
	Transfer of Utility Billings	7.11-5
7.11.6	WARRANTY.....	7.11-5
	Start of Warranty	7.11-5
	One Year Warranty (for overall facility).....	7.11-5
	Two Year Warranty (for Major Equipment)	7.11-5
	Extended Warranty.....	7.11-5
	Warranty Service.....	7.11-6

Warranty Ownership	7.11-6
7.11.7 FACILITY TRAINING	7.11-6
7.11.8 KEYING SYSTEM.....	7.11-6
City Standard Locks	7.11-6
Number of Key Sets	7.11-6

LIST OF TABLES

Table 1-1	City of San Diego Density Conversions.....	1-17
Table 2-1	Interval of Cutoff Walls or Concrete Anchors	2-8
Table 2-2	Radius of Curvature for Pipe Deflection	2-9
Table 2-3	Minimum Allowable Radius of Curvature	2-10
Table 2-4	Distance Between Manholes	2-14
Table 2-5	Invert Drops Across Manholes.....	2-18
Table 2-6	Sewer Lateral Connections.....	2-22
Table 2-7	Minimum Rises from Sewer Mains.....	2-23
Table 2-8	Sewer Main Abandonment.....	2-34
Table 2-9	Sewer Data Table	2-34
Table 2-10	Sewer Lateral Table.....	2-34
Table 3-1	Worksheet for Calculating Required Sewer Easement Widths	3-5
Table 5-1	Sewer Main Abandonment.....	5-1
Table 6-1	Material Selection Guide.....	6-4
Table 6-2	Coating Selection Guide.....	6-5
Table 6-3	Lining Selection Guide.....	6-6
Table 6-4	Resistivity Values - Corrosivity	6-8
Table 6-5	Corrosive Effect of Chlorides or Sulfates on Steel or Concrete.....	6-9
Table 6-6	Acceptable Coatings/Linings for Sewer Pump Station Piping	6-12
Table 6-7	Force Main Corrosion Protective Coatings and Linings	6-13
Table 7.1-1	Design Review Comments Form	7.1-2
Table 7.2-1	Flow Data	7.2-7
Table 7.2-2	Ratio of Minimum to Average Flow	7.2-8
Table 7.5-1	Conduit Routing Schedule.....	7.5-4
Table 7.7-1	Exposed Piping Identification Schedule.....	7.7-5
Table 7.7-2	Color Identification Schedule for Equipment and Associated Piping	7.7-6

LIST OF FIGURES

	<u>At End of</u>
Figure 1-1	Peaking Factor for Sewer Flows (Dry Weather) Chapter 1
Figure 1-2	Sewer Study Summary Sheet Chapter 1
Figure 2-1	Gas Trap Chapter 2
Figure 2-2	Joint Deflection Allowances Chapter 2
Figure 2-3	Sewer Manhole Coating and Lining..... Chapter 2
Figure 2-4	Pipe Locations for Straight-Through Flow (Outlet Pipe = Inlet Pipe) ... Chapter 2
Figure 2-5	Pipe Locations for Straight-Through Flow (Outlet Pipe >Inlet Pipe) Chapter 2
Figure 2-6	Private Sewer Lateral in Concrete Cement Driveway Chapter 2
Figure 3-1	Sewer Access Roads - New Sewers in ESL's Chapter 3
Figure 3-2	Sewer Access Paths - Existing Sewers in ESL's..... Chapter 3
Figure 4-1	Sewer Main Installation in Box Girder-Type Bridge Chapter 4
Figure 4-2	Sewer Main Installation in Open Girder-Type Bridge Chapter 4
Figure 4-3	Sewer Main Installation on Slab-Type Bridge Chapter 4
Figure 4-4	Sewer Main Installation on Dual Bridges (All Types) Chapter 4
Figure 4-5	Abutment Details..... Chapter 4
Figure 4-6	Pipe Saddles Chapter 4
Figure 4-7	Mercy Road Bridge Water Transmission Line (Existing)..... Chapter 4
Figure 4-8	Robinson Avenue Bridge 16" Force Main (Existing) Chapter 4
Figure 5-1	Subterranean Facility Abandonment Agreement Chapter 5

INDEX

ATTACHMENT 1

CITY OF SAN DIEGO COUNCIL POLICIES 400-13 AND 400-14

ATTACHMENT 2

DEVIATION FROM STANDARDS FORM

ATTACHMENT 3
A-3.1 GENERAL**A-3.2 ELECTRICAL STANDARDIZED DESIGNS AND SPECIFICATIONS**

- Section 16040 - Electric Motors
- Section 16110 - Raceways, Fittings, and Supports
- Section 16120 - Wire and Cable
- Section 16130 - Junction and Device Boxes and Fittings
- Section 16150 - Wiring Devices
- Section 16155 - Motor Starters
- Section 16160 - Control Cabinets and Panel Devices
- Section 16400 - Electrical Service Equipment
- Section 16440 - Disconnect Switches and Fuses
- Section 16450 - Grounding
- Section 16460 - Dry Type Transformers
- Section 16470 - Panelboards
- Section 16480 - Motor Control Centers
- Section 16500 - Lighting Fixtures
- Section 16700 - Supervisory Control and Data Acquisition (SCADA), Gas Detection and Intrusion Systems
- Section 16900 - Controls and Instrumentation

A-3.3 STANDARD DRAWINGS (FIGURES 1 TO 30)

<u>File Name</u>	<u>Figure</u>	<u>Title</u>
E1.dgn	SE-1	Typical Electrical Symbols and legends
E2.dgn	SE-2	Typical Electrical Symbols and legends
E3.dgn	SE-3	Site Plan and Notes
E4.dgn	SE-4	Typical Single Line Diagrams
E5.dgn	SE-5	Typical MCC Details, Light Fixture Schedule
E6.dgn	SE-6	Typical Conduit Schedules
E7.dgn	SE-7	Typical Roof Level Power and Lighting Plans
E8.dgn	SE-8	Typical Generator Room Level Power Plan
E9.dgn	SE-9	Typical Generator Room Level Lighting Plan
E10.dgn	SE-10	Typical Pump Room Level Power and Lighting Plan

<u>File Name</u>	<u>Figure</u>	<u>Title</u>
E11.dgn	SE-11	Typical Panel Schedule and Details
E12.dgn	SE-12	Typical Miscellaneous Details
SPS9A_16.dgn	SE-13	WWCD SCADA Project, Standard Sewer Pump Station, Pump No.1 Control Schematic
SPS9A_17.dgn	SE-14	WWCD SCADA Project, Standard Sewer Pump Station, Pump No. 2 Control Schematic
SPS9A_18.dgn	SE-15	WWCD SCADA Project, Standard Sewer Pump Station, Pump No. 3 Control Schematic
3PUMP_3.dgn	SE-16	WWCD SCADA Project Standard Sewer Pump Station, Pump Control Schematic Power Distribution
3PUMP_4.dgn	SE-17	WWCD SCADA Project, Standard Sewer Pump Station Pump Control Schematic Pump No.1
3PUMP_5.dgn	SE-18	WWCD SCADA Project, Standard Sewer Pump Station Pump Control Schematic Pump No.2
3PUMP_6.dgn	SE-19	WCD SCADA Project, Standard Sewer Pump Station Pump Control schematic Pump No.3
3PUMP_7.dgn	SE-20	WWCD SCADA Project, Standard Sewer Pump Station Pump Control Schematic Gas/Generator Monitoring
3PUMP_8.dgn	SE-21	WWCD SCADA Project, Standard Sewer Pump Station Pump Control Schematic Pump Alarms
3PUMP_9.dgn	SE-22	WWCD SCADA Project, Standard Sewer Pump Station Pump Control Schematic Level Control Monitoring
3PUMP_10.dgn	SE-23	WWCD SCADA Project, Standard Sewer Pump Station Pump Control Schematic Pump No. 1 PLC Discrete Inputs
3PUMP_11.dgn	SE-24	WWCD SCADA Project, Standard Sewer Pump Station Pump Control Schematic Pump No. 2 PLC Discrete Inputs
3PUMP_12.dgn	SE-25	WWCD SCADA Project, Standard Sewer Pump Station Pump Control Schematic Pump No.3 PLC Discrete Inputs
3PUMP_13.dgn	SE-26	WWCD SCADA Project, Standard Sewer Pump Station Pump Control Schematic Gas Generator PLC Discrete Inputs
3PUMP_14.dgn	SE-27	WWCD SCADA Project, Standard Sewer Pump Station Pump Control Schematic PLC Discrete Outputs

<u>File Name</u>	<u>Figure</u>	<u>Title</u>
3PUMP_15.dgn	SE-28	WWCD SCADA Project, Standard Sewer Pump Station Pump Control Schematic PLC Discrete Outputs
3PUMP_1.dgn	SE-29	WWCD SCADA Project, Standard Sewer Pump Station Pump Control Panel Outside Elevation
3PUMP_2.dgn	SE-30	WWCD SCADA Project, Standard Sewer Pump Station Pump Control Panel Inside Elevation

A-3.4 PUMP CONTROL SCHEMATIC FLOW CHARTS (FIGURES 1 TO 12)

<u>File Name</u>	<u>Figure</u>	<u>Title</u>
FIGURE_1.dgn	1	Level Monitoring and Scaling
FIGURE_2.dgn	2	Initial Pump Calls
FIGURE_3.dgn	3	Check Valve Fail
FIGURE_4.dgn	4	Pump N Availability
FIGURE_5.dgn	5	Pump N Run Time Service Call
FIGURE_6.dgn	6	Pump Run Time Out
FIGURE_7.dgn	7	Pump N Run Sequence Fail
FIGURE_8.dgn	8	Pump N Fail/Alarm
FIGURE_9.dgn	9	Call 1 Pump Sequence Typical for All Calls
FIGURE_10.dgn	10	Station Power Monitor
FIGURE_11.dgn	11	Hardwired Float Switch Level Monitoring
FIGURE_12.dgn	12	Station Communication Via Radio

A-3.5 SCADA OVERVIEW BLOCK DIAGRAMS (FIGURES 1 TO 3)

<u>File Name</u>	<u>Figure</u>	<u>Title</u>
FIGURE_1.dgn	1	WWCD SCADA Project Sewer Pump Station Programmable Logic Controller Interconnect Diagram
FIGURE_2.dgn	2	WWCD SCADA Project Repeater Station Programmable Logic Controller and Radio Component
FIGURE_3.dgn	3	WWCD SCADA Project Communication Schematic

ATTACHMENT 4

APPROVED PLANTING PALETTE FOR ACCESS FACILITY PLANT MATERIAL

ATTACHMENT 5

MINIMUM INTAKE CHECKLIST FOR CONSTRUCTION DOCUMENTS

ATTACHMENT 6

PRIVATE ON-SITE WASTEWATER TREATMENT AND REUSE

SEWER DESIGN GUIDE

INTRODUCTION

This *Sewer Design Guide* sets forth criteria to be used for the design of sewer systems which may consist of pump stations, gravity sewers, force mains, and related appurtenances. It includes criteria for determining capacity and sizing of pump stations, gravity sewers and force mains, alignment of gravity sewers and force mains, estimating wastewater flow rates, design of bridge crossings, and corrosion control requirements.

The DESIGN ENGINEER for a sewer system, especially pump stations, shall coordinate their design with the appropriate City departments to ensure that their project is part of the City's master plan for the affected conveyance system. The DESIGN ENGINEER shall also determine and ensure that there is capacity in the sewer system downstream of the tributary areas planned for development. Project applicants shall contact the Public Utilities Department Senior Civil Engineer when the wastewater flow estimates of individual areas planned for development generate more than 5 percent of the wastewater stream at the point of connection with the City's sewer lines and to verify that downstream mains are not identified on the City's list of critical sewers. The intent of this requirement is to ensure that flows from new projects will not adversely affect the downstream conveyance systems operated by the City and to ensure that previous studies have accounted for those flows in the design of the City's downstream conveyance systems.

There may be some equipment brand names or specific manufacturers mentioned by name in this *Sewer Design Guide*. The purpose of mentioning these names is primarily to establish a level of quality rather than to restrict the procurement to only the named manufacturers. In some cases, the City Project Manager, the City DESIGN ENGINEER, or the Public Utilities Department Senior Civil Engineer may direct the DESIGN ENGINEER or land developers to specify brand names to match existing equipment or for safety and maintenance-related reasons. In such cases, the DESIGN ENGINEER shall specify the brand names of the designated manufacturers. The current list of City approved materials for sewer applications may be viewed at:

<http://www.sandiego.gov/mwwd/pdf/approvedmaterials.pdf>

The focus of this *Sewer Design Guide* is the design of sewer systems which may include pump stations with a capacity of less than 3 million gallons per day (mgd) and trunk sewers. For pump stations greater than 3 mgd, the design criteria are provided in the Clean Water Program (CWP) Guidelines (Volume I through Volume X). However, it should be noted that the CWP Guidelines are written primarily for facilities related to wastewater treatment and reclamation plants, including large influent pump stations on major trunk and interceptor sewers. Consultants and design engineers should recognize that this limit of 3 MGD is somewhat arbitrary and could be changed on the basis of

project needs. The Public Utilities Department Senior Civil Engineer, or the City Project Manager, in consultation with the Wastewater Collection Division, which has the ultimate responsibility for operating and maintaining the City's sewer system, may revise this limit on a case by case basis.

It should be understood that the design of a pump station will require specifications in other disciplines such as civil, structural, mechanical, and architectural. Sample specifications in these disciplines are found in Volumes V and VI of the CWP Guidelines. The DESIGN ENGINEER should use the specifications in these two volumes as applicable to their project. There may be other project specifications not covered by this *Sewer Design Guide* or by the CWP Guidelines. It shall be the responsibility of the DESIGN ENGINEER to develop specifications for those other project disciplines from their own resources. When using the referenced Design Standards and Specifications, or other specifications included in Volumes V and VI of the CWP Guidelines, it is the responsibility of the DESIGN ENGINEER to modify or provide design documents adequate to meet the needs of each specific project.

This *Sewer Design Guide* governs all public sewer systems which are maintained by the MWWD as well as those private mains which serve multiple lots. Private mains which serve only one lot are governed by the applicable sections of the adopted plumbing code and require a private plumbing permit.

ELECTRONIC FILE OF THE SEWER DESIGN GUIDE

For benefit of the public, the *Sewer Design Guide —2013 Edition* is posted on the City of San Diego Website in PDF Format. The hyperlink to the electronic file is:
<http://www.sandiego.gov/mwwd/pdf/sewerdesign.pdf>

DEVIATIONS FROM THE SEWER DESIGN GUIDE

The DESIGN ENGINEER shall direct all project specific deviations from the *Sewer Design Guide*, and/or other referenced specifications, to the attention of the City Senior Civil Engineer. The City Senior Civil Engineer, in consultation with the Project Engineer and other staff, will evaluate the request for deviation and, based on the evaluation, will decide whether to accept or reject the proposed deviation. The DESIGN ENGINEER shall prepare the request for deviation using the format of **ATTACHMENT 2**, which is included as a part of this document.

CHAPTER 1 SEWER SYSTEM PLANNING**1.1 GENERAL**

This Chapter covers criteria for estimating wastewater flows and sewer flow rates, sizing of sewer pipes, determining separation of sewer gravity and force mains from other utilities, and the planning and design of sewer pump stations. An approved sewer planning study shall be conducted to identify pipe diameters and alignments of all existing and proposed sewer mains. The study report shall include a summary of the estimated wastewater flows, all hydraulic calculations, a table indicating capacity, depth, and slope of sewer mains including separation from other pipelines, and the associated sewer maps. Citizens and regulatory agencies understand that the design, location, and installation of a sewer system can significantly impact a community or development's quality of life, safety, and environment. As a result, the design of a sewer system must be integrated into the community's overall planning efforts early on in the project. Where good design alone cannot satisfy the needs and requirements of the public, city planners, and regulatory agencies, the Senior Civil Engineer will endeavor to work with the DESIGN ENGINEER to resolve conflicts which may arise. The DESIGN ENGINEER shall strive to identify potential problems at the earliest stage and meet with the Senior Civil Engineer to develop or present alternative solutions during the project's preliminary engineering phase. The planning and design of sewer facilities shall conform to the Land Development and Municipal Codes. The majority of the information in the municipal code for sewer improvements can be found in Chapters 6 and 14.

1.2 PRELIMINARY PROJECT PLANNING**1.2.1 Alignment and Grade of Mains****1.2.1.1 New Mains**

Community plans and new developments shall be designed to accommodate gravity sewer facilities at standard depth and grade, and shall be located within street right-of-way, wherever possible. A gravity sewer system shall typically be accomplished through land form modification, re-grading and contouring, and street layout. In general, sewer mains shall be aligned in streets where at all possible. However, where new sewers must be located in canyons and other environmentally sensitive lands, pipeline planning, design, construction and requirements of the Maintenance Access Plan shall comply with Council Policies 400-13 and 400-14 (ATTACHMENT 1). Sewer mains serving only one property shall be private, and shall be permitted as part of the Plumbing Permit. All projects shall include enough space for both wet and

dry utilities so that no other utilities are located within 10 feet of the sewer mains horizontally. If mains are deeper than 10 feet, additional width is required per Chapter 3 of this *Sewer Design Guide*.

1.2.1.2 **Relocated Mains**

Sewer mains installed to replace facilities in existing developed lands shall generally follow existing alignments, but may be realigned as deemed necessary to achieve optimum flow conditions, reasonable access, and prescribed separation from existing utility infrastructures. Where possible, existing sewer mains in easements shall be relocated to nearby streets; all existing sewer laterals shall be rerouted (Ref. Municipal Code §144.0240). In general, every effort shall be made to avoid the installation of pumps on either relocated sewer mains or impacted sewer laterals. If an adjacent sewer is located in canyons and/or environmentally sensitive areas, the project shall relocate the sewer main within the limits of the project where possible (Ref. Municipal Code §144.0240(a)). Where existing sewers are located in canyons and other environmentally sensitive lands, pipeline planning, design, construction and the Maintenance Access Plan requirements shall comply with Council Policies 400-13 and 400-14 (ATTACHMENT 1).

1.2.1.3 **Precedence of Sewer Facilities**

When a project and/or portion of a project cannot be reasonably designed to meet the requirements listed above, the sewer system shall be designed with the following types of facilities, listed below in order of precedence:

- 1) Gravity sewers in private paved streets, alleys, or parking lots.
- 2) Gravity sewers in readily accessible park greenbelt lands, with paved sewer access roads.
- 3) Pump stations or gravity sewers in canyons and/or environmentally sensitive lands with permanent sewer access roads provided. In such cases, the DESIGN ENGINEER shall ensure that the project complies with the requirements of Council Policies 400-13 and 400-14 (ATTACHMENT 1).

1.2.1.4 **Private Mains**

Where mains are within private property and serve only that property, the mains shall be private and shall require a plumbing permit. An example would be an apartment complex or a condominium complex where no offsite flows contribute to the onsite main. In a condominium project where each unit fronts a public street or public alley, and each of the units is served by an individual lateral, the main may be public. In such cases, Covenants, Conditions and

Restrictions (CC&R) may be written so that the owner of each unit is responsible for his/her own lateral.

Onsite private mains shall be designed and constructed to the Uniform Plumbing Code as adopted by the City of San Diego. If improvements other than retaining walls are constructed as part of the mass grading permit, then the engineer is responsible to obtain a separate plumbing permit for onsite private mains. If site improvements are to be constructed with the building, then the project building engineer, or the architect in the absence of the engineer, shall be responsible for ensuring that a separate plumbing permit is acquired for all onsite sewer mains to the point of connection to the main as shown on the public improvement drawings.

1.2.1.5 **Easements for Mains**

Public mains outside of the public right-of-way shall have permanent easements of adequate width for maintenance, repair, replacement, and rehabilitation. All appurtenances and isolated reaches of a main shall have a permanent access easement for maintenance vehicles/equipment. (Refer to Chapter 3 for specific requirements).

1.2.2 **Pump Station Location**

If possible, a new private development or existing community sewer improvement project shall be designed to eliminate the need for a sewer pump station. However, in canyons and environmentally sensitive lands, the need for a pump station shall be considered against other options in conformity with Council Policies 400-13 and 400-14 (ATTACHMENT 1).

1.2.3 **Sewers in Canyons and Environmentally Sensitive Lands**

Installation of sewer mains in environmentally-sensitive lands, canyons or preserves shall be limited and shall comply with Council Policies 400-13 and 400-14 (ATTACHMENT 1). However, if such areas must be impacted, the DESIGN ENGINEER shall consider the following:

- a. For new development without access to an existing canyon sewer, the entire sewer system shall be located within the areas of the subdivision to be developed. This will require coordination between adjacent canyon rim (and perhaps other) developments and may include appropriate location and grade of streets, land form modification, etc.
- b. For sewer main replacement projects in canyons within existing developed areas, every reasonable attempt shall be made to relocate the canyon sewer mains and their connected sewer laterals to nearby City

streets, in accordance with Council Policies 400-13 and 400-14 (ATTACHMENT 1).

- c. As development or redevelopment occurs, existing sewers in environmentally-sensitive areas shall be relocated to streets or other appropriate areas where possible (Ref. Municipal Code §144.0240(a)).
- d. Where an existing canyon sewer main has capacity to serve a new development, the number of sewer mains penetrating the canyon from a new development shall be limited. This shall require coordination with other new developments wanting to access the same canyon sewer main. Sewer main access roads shall be provided to the point of connection and to the extent of all new manholes, and shall be coordinated with other access requirements, such as equestrian, pedestrian, multiple-use recreational trails, or storm water detention/retention/remediation facilities. However, all sewer access in canyons or other environmentally-sensitive lands shall be designed in conformance with Council Policies 400-13 and 400-14 (ATTACHMENT 1).
- e. To assist in determining where to direct sewer flow or where new sewer facilities may be located within canyons and environmentally-sensitive lands, a cost-benefit analysis shall be conducted per Council Policy 400-14 (ATTACHMENT 1).
- f. Sewer access roads that penetrate into canyons shall not exceed the maximum allowable slope (Ref. Subsection 3.2.3.4c) and shall be aligned along the centerline of the sewer main as much as practicable.
- g. To assist in determining where new sewer facilities and sewer access roads may be located within canyons and environmentally-sensitive lands, a sewer maintenance plan shall be prepared in accordance with Council Policy 400-13 (ATTACHMENT 1).

1.3 PLANNING STUDY

1.3.1 General Requirements

For a new development and/or redevelopment, a sewer planning study for new sewer facilities shall be prepared, as directed by the Senior Civil Engineer, to demonstrate that there are no negative impacts on the existing sewer system. A minimum of three (3) copies of the planning study shall be submitted, each stamped and wet/electronically signed by a Civil Engineer registered in the State of California. Each study shall be bound and formatted in accordance with this *Sewer Design Guide* and/or the *Clean Water Program (CWP) Guidelines*.

The final approved sewer study shall also be submitted electronically in PDF format.

For new development, the planning study must be approved prior to approval of the tentative map. The study shall include all items listed in the minimum intake standards for sewer studies and subsequent reviews shall include an explanation for each review comment.

1.3.1.1 **Capacity**

For new development and/or redevelopment, the planning study shall address the capacity of all sewer collection and trunk sewer systems that will be impacted downstream of the new development and/or redevelopment and shall demonstrate that sewer capacity is available in those systems to accommodate the new development and/or redevelopment (refer to Section 1.7). Authorization and approval to impact any downstream sewer system must be obtained from the reviewing Senior Civil Engineer. If such downstream sewer system has already been identified as critical or sub-critical in a monitoring report, the Senior Civil Engineer may require additional field monitoring to determine if adequate capacity is available.

For an existing development and/or redevelopment, the planning study shall address the existing capacity within the existing sewer collection system, and identify all existing facilities whose capacity will be exceeded by projected sewage flows.

Where available capacity will be exceeded, the planning study shall propose upsizing of sewer facilities in accordance with Subsection 1.3.3.

Where applicable, the DESIGN ENGINEER shall incorporate into the community's existing master sewer plan, including zoning changes and other specific plans, the proposed sewer system amendments resulting from the drainage basin evaluation.

1.3.1.2 **Drainage Basin**

The planning study shall address the sewage generating potential of the entire drainage basin where the development is located. It shall also include current topographic maps of the entire drainage basin and any and all adjacent new developments for which a planning study has not yet been submitted and/or approved. The maps shall demonstrate that no adjacent development, including potential and existing pumped lands outside of the drainage basin and any lands outside of the incorporated boundaries of the City of San Diego with potential to be served but where no current master sewerage plan exists, will be precluded from obtaining sewer service. The planning study shall also show all proposed sewer system alignments (superimposed on planned

street alignments) and all potential points of entry of sewage from surrounding lands.

1.3.1.3 **Depth of Mains**

The planning study shall clearly identify all existing and/or proposed facilities which will exceed standard depths for sewer mains as defined in Subsection 2.2.1.5. In cases where proposed sewers will exceed 15 feet in depth, a request for design deviation (ATTACHMENT 2) must be submitted to the Water and Sewer Development Review Senior Civil Engineer with the Sewer Planning Study. A design deviation will only be approved in exceptional cases and when adequate justification is provided. Mains more than 20 feet deep shall also require approval from the Wastewater Collection Division Senior Civil Engineer.

1.3.1.4 **Existing Studies**

The City of San Diego maintains an extensive library of sewer planning studies which were prepared for lands throughout the City. These studies are available for review at the Water and Sewer Development Section, Public Utilities Department. All studies are catalogued by subdivision or trunk sewer name. Logs of sewer flow study analyses for recently monitored trunk sewers and a map of sewers which meet the Regional Water Quality Control Board (RWQCB) criteria for being critical or sub-critical may also be viewed. In addition, information regarding proposed CIP projects within the vicinity of a given project may be requested. In many cases, an addendum or reference to one of the existing planning studies may be acceptable in lieu of an independent study. Concurrent with the preparation of planning studies for sewers proposed to connect to existing canyon sewer mains, a study of flow redirection per Council Policy 400-13 and a cost-benefit analysis per Council Policy 400-14 shall be prepared (Refer to ATTACHMENT 1). An existing analysis of redirection of flows and a cost-benefit analysis, as required by Council Policies 400-13 and 400-14 respectively, may be available for reference for various existing canyon sewers.

1.3.2 **Flow Estimation**

1.3.2.1 **Land Use**

Present or future allowable land use, whichever results in higher equivalent population, shall be used to generate potential sewage flows.

1.3.2.2 **Flow Determination**

Flow definitions and calculation procedures are listed below. All calculations shall be tabulated for each sewer main section (manhole to manhole) in the

format shown on Figure 1-2.

Equivalent Population: The equivalent population shall be calculated from zoning information (Ref. Section 1.6). For major new facilities such as high rise apartment buildings, flow rates (assuming one lateral) shall be checked based on the most current, adopted edition of the Uniform Plumbing Code. The most conservative flow rate shall govern.

Daily Per Capita Sewer Flow: The sewer flow for the equivalent population shall be 80 gallons per capita per day (gpcd).

Average Dry Weather Flow (ADWF): Equivalent populations shall be used to calculate the average dry weather flow. The average dry weather flow for each sewer main reach (manhole to manhole) shall be determined by multiplying the total accumulated equivalent population contributing to that reach by 80 gallons per capita per day:

$$\text{Average Dry Weather Flow} = (80 \text{ gpcpd}) \times (\text{Equivalent Population})$$

Peaking Factor for Dry Weather Flow (PFDWF): The peaking factor is the ratio of peak dry weather flow to average dry weather flow. It is dependent upon the equivalent population within a tributary area. The tributary area is the area upstream of, and including, the current reach for the total flow in each reach of pipe. Figure 1-1, consisting of the table prepared by Holmes and Narver in 1960, shall be used to determine peaking factors for each tributary area. In no instance shall the dry weather flow peaking factor be less than 1.5.

Peak Dry Weather Flow (PDWF): The peak dry weather flow for each sewer main reach shall be determined by multiplying the average dry weather flow by the appropriate peaking factor (Note that peak dry weather flows are not algebraically cumulative as routed through the sewer system, i.e. the peak dry weather flow at any point shall be based on the equivalent population in the basin to that point (Ref. Figure 1-2).

$$\text{Peak Dry Weather Flow} = (\text{Average Dry Weather Flow}) \times (\text{Dry Weather Flow Peaking Factor})$$

Peaking Factor for Wet Weather Flow (PFWWF): The peaking factor for wet weather flow is the ratio of peak wet weather flow to peak dry weather flow. It is basin-specific and shall be based on essential information available at the time of the planning study. Information such as historical rainfall/sewage flow data, land use, soil data, pipe/manhole age, materials and conditions, groundwater elevations (post development), inflow and infiltration (I/I) studies, size, slope and densities of the drainage basin, etc., should be utilized in the wet weather analysis to estimate the peaking factor for wet weather. Upward adjustments shall be made in areas with expected high inflow and

infiltration (i.e. high ground water or in areas with lush landscaping schemes). Flow meters are installed throughout the City's sewer system. Flow data collected from these meters are available upon request. The objective of this analysis is to quantify the magnitude of peak wet weather flow with a 10-year return period on a statistical basis.

The Senior Civil Engineer overseeing the preparation of the planning study shall coordinate with the City Sewer Modeling Group for approval of the peaking factors to be used for design.

Peak Wet Weather Flow (PWWF): The peak wet weather flow (or design flow) for a gravity sewer main reach shall be determined by multiplying the peak dry weather flow (ref. Figure 1-2) by the appropriate wet weather peaking factor. The peak wet weather flow is the design flow for a gravity sewer main. It is determined at any point in the system based on the associated upstream average dry weather flow in the basis to that point times the peaking factor for wet weather.

$$\text{Peak Wet Weather Flow} = (\text{Peak Dry Weather Flow}) \times (\text{Wet Weather Peaking Factor})$$

1.3.3 Pipe Sizing Criteria

1.3.3.1 Hydraulic Requirements

Manning's formula for open-channel flows shall be used to calculate flows in gravity sewer mains. Manning's coefficient of roughness "n" shall be assumed to be 0.013 for all types of sewer pipe. Sewer grades shall be designed for velocities of 3 to 5 feet per second (fps) where possible. This is extremely important in areas where peak flow will not be achieved for many years. The minimum allowable velocity is 2 fps at calculated peak dry weather flow, excluding infiltration. Sewer mains that do not sustain 2 fps at peak flows shall be designed to have a minimum slope of 1 percent. Additional slope may be required by the Senior Civil Engineer where fill of varied depth is placed below the pipe in order to provide adequate slope after expected settlement occurs. The maximum allowable velocity shall be 10 fps and shall be avoided by adjusting slopes, by increasing the pipe diameter, or by utilizing a vertical curve transition to lower velocities per subsections 2.2.4 and 2.2.9.4. If the Senior Civil Engineer approves a velocity greater than 10 fps, the pipe shall be upgraded to SDR 18 PVC (standard dimension ratio polyvinyl chloride), concrete-encased VC (vitrified clay), or PVC sheet-lined reinforced concrete pipe.

1.3.3.2 **Slope**

Slope shall be calculated as the difference in elevation at each end of the pipe divided by the horizontal length of the pipe, and shall be a constant value between manholes.

1.3.3.3 **Ratio of Depth of Flow to Pipe Diameter (d_n/D)**

New sewer mains 15 inches and smaller in diameter shall be sized to carry the projected peak wet weather flow at a depth not greater than half of the inside diameter of the pipe (d_n/D not to exceed 0.5). New sewer mains 18 inches and larger shall be sized to carry the projected peak wet weather flow at a depth of flow not greater than 3/4 of the inside diameter of the pipe (d_n/D not to exceed 0.75).

1.3.3.4 **Minimum Pipe Sizes**

The size of a sewer pipe is defined as the inside diameter of the pipe. Sewer mains shall be a minimum of 8 inches in diameter in residential areas, and a minimum of 10 inches in commercial, industrial, and high-rise building areas.

1.3.4 **Sewer Study Exhibit Criteria**

The DESIGN ENGINEER's sewer study exhibits shall be used to evaluate hydraulics and to establish minimum street and easement widths. Therefore, these documents need to reflect depths and separation of mains from other utilities and improvements. Refer to the Minimum Intake Standards for Sewer Studies in Subsection 1.8.

1.3.5 **Private On-Site Wastewater Treatment and Reuse**

Refer to Attachment 6 for permitting guidelines of private on-site wastewater treatment and reuse in the City of San Diego.

1.4 **SEPARATION OF MAINS**

1.4.1 **Horizontal Separation**

1.4.1.1 **Wet Utilities**

The separation of water, sewer, reclaimed water mains, and storm drains shall comply with the *State of California Department of Health Services Criteria for the Separation of Water Mains and Sanitary Sewers*. At least 10 feet of horizontal separation shall be maintained between the nearest outer surfaces of sewer lines and potable water mains. More stringent separation requirements

may be necessary if unusual conditions, such as high groundwater levels or large diameter mains, exist (Ref. State of California “Blue Book”). If a horizontal separation of 10 feet or other requirement is not possible, a deviation from standards may be permitted by the City provided the structural integrity of both the pipe and the pipe joints is upgraded in accordance with the *State of California Department of Health Services Criteria for the Separation of Water Mains and Sanitary Sewers - Special Provisions*, and provided it has been reviewed and written approval has been obtained from the California Department of Health Services, Drinking Water Field Operations Branch. This deviation is not applicable for subdivisions, or where sewers are placed in new streets. Lateral connections to sewer mains typically do not meet the upgraded joint requirements for reduced separation. All installations of sewer mains which fail to comply with the basic separation standards must be reviewed and approved by the State of California Department of Health Services. For separation from curbs, see Subsection 2.2.5.2. For separation from structures, see Subsections 2.2.5.8 and 2.2.5.9.

1.4.1.2 **Separation for Dry Utility Pipes and Cable Conduits**

Other utility pipes, conduits, and cable lines shall be governed by their respective franchise agreement with the City of San Diego. A minimum 10-foot horizontal separation is desirable between sewer mains and any other utility infrastructure. Separations of less than 10 feet must be approved by the Senior Civil Engineer of Water and Sewer Development Section, Public Utilities Department. Additional separation may be required for sewer mains which exceed 10 feet in depth. The DESIGN ENGINEER shall consider the relative depth of adjacent utilities and the stability of the soils where the sewer shall be constructed when designing the separation from other utilities. Refer to San Diego Regional Standard Drawing (SDRSD) M-22 and City of San Diego Drawing SDM-111 for standard locations of utilities in streets.

1.4.2 **Vertical Separation**

1.4.2.1 **Shallow Mains, General**

Shallow mains require a special design. Review and written approval is required from the California Department of Health Services, Drinking Water Field Operations Branch for deviations from vertical separation requirements for water and sewer utilities. For mains less than 4 feet deep, special design shall be required for live and dead loads and vertical cyclical deflections which shall include an evaluation to demonstrate zero deflection in the pavement.

1.4.2.2 **Parallel Mains**

Potable water, reclaimed water, and sewer mains shall be located at various

depths below the ground surface, in order of descending water quality. Potable water pipelines shall be located above both reclaimed water pipes and sewer mains, and reclaimed water mains shall be located above sewer mains. A minimum vertical separation of one foot shall be provided between the top and bottom surfaces of the pipes in the same street or easement.

1.4.2.3 **Crossing Mains**

A minimum vertical separation of 12 inches shall be provided between the top and bottom surfaces of crossing utility conduits and shall comply with the *State of California Department of Health Services Criteria for the Separation of Water Mains and Sanitary Sewers*. Separation measurements shall be taken from the outer most surface of any pipeline protection (i.e. concrete encasement or steel sleeve) which may be installed. Where the vertical separation is less than 12 inches, a request for design deviation (ATTACHMENT 2), with justification, shall be submitted for review. If approved, for pipes 12 inches or less in diameter, a 12-inch sand cushion, or alternatively a minimum 6-inch sand cushion with 1 inch neoprene pad shall be used. Separations of less than 7 inches will not be allowed by the City. For skewed main crossings, see Subsection 2.2.6. Mains crossing large facilities shall evaluate deflection across the span, changes in hydraulics due to change of slope, shear forces, and special joint designs to account for pipe movement.

1.5 **PUMP STATION PLANNING CRITERIA**

If at all possible, the construction of a sewer pump station is to be avoided. However, in cases where constraints such as topography and environmentally sensitive habitat dictate, a pump station may be necessary (Ref. Council Policies 400-13 and 400-14 – ATTACHMENT 1). The DESIGN ENGINEER shall analyze the planning area for the sewer system to minimize the number of units to be pumped and to design the shortest possible force main. In cases where only a small tributary area is to be served by a pump station, the City will accept the facility as public only if it can be shown that the capitalized cost of facility replacement and maintenance will not exceed 50 percent of the standard sewer fees for the area to be served. Otherwise, the pump station must be privately owned, maintained and operated. In cases where a pump station will be a public facility, specific criteria for the design, construction, and operational testing of sewer pump stations are given in Chapter 7.

1.5.1 **Pump Station Design Capacity**

The Pump Station Design Capacity shall be calculated as follows:

Pump Station Design Capacity (PSDC): Pump stations shall be designed to pump the calculated peak wet weather flow from the upstream tributary area.

Pump Station Reserve Capacity Factor (PSRCF): This is a safety factor that takes into account that service pumps will generally not be operating at their

full intended design capacity due to mechanical wear and the subsequent loss of efficiency, and increases in force main friction loss due to the deposition of solids and grit. The reserve capacity factor shall be 1.0 if two (2) hours emergency storage (Ref. Subsection 7.2.6.7) or six hours emergency storage (Ref. Subsection 7.2.7) are provided. Where this storage is not provided in design, then a reserve capacity factor greater than 1.0 shall be used and an appropriate factor shall be evaluated for approval, on a case-by-case basis, by the Wastewater Collections Division Senior Civil Engineer.

$$\text{Pump Station Design Capacity} = (\text{Peak Wet Weather Flow}) \times (\text{Pump Station Reserve Capacity Factor})$$

1.5.2 Private Pump Stations

Private pump stations (privately-owned and operated) serving more than one lot shall not be located in the public right-of-way. The capacity for private pump stations shall be determined in the same manner as for public pump stations. Station wet well detention times shall not exceed 4 hours. A planning study for the pump station outlining capacity of the pumps, equivalent dwelling units (EDU) served, capacity of the wet well, detention times, length and size of the force main, and provision of any odor control equipment shall be submitted for review to Water and Sewer Development Review, Public Utilities Department. Private pump stations shall require separate structural, mechanical, and electrical permits from the City of San Diego, Development Services Department, Building Review Division. However, private pump station plans are not reviewed for compliance with City of San Diego Sewer Design Guide Chapter 7 criteria. As such, it shall be the responsibility of the DESIGN ENGINEER to ensure that all private pump stations are adequately sized, have sufficient redundant measures (dual force mains, back-up power supply, auto dialer alarm system to a licensed plumber with 24-hour response, etc.), and comply with all applicable local, state, and federal regulations. In the design of such facilities, the DESIGN ENGINEER shall utilize sound engineering judgment to provide for an adequate design for any potential failure during the service life of the pump station. If a developer elects to construct a private sewer system including a sewer pump station, then a letter of agreement must be executed over all lots served in the subdivision if the pump station will serve two or more lots. A copy of this agreement is available at the City Plan Check Counter and the City Website <http://www.sandiego.gov/mwwd/business/sewer>. Also required is a recorded copy of the CC&R's for the home or business owners association, outlining the responsibility and maintenance requirements for the shared private improvements.

1.6 ZONE - DENSITY CONVERSIONS

Table 1-1 shall be used in planning studies to determine the equivalent

population for a given land use. These tabulated figures represent a general case analysis. When more accurate or detailed information, such as fixture unit counts, is available, Table 1-1 shall not be used. For more information on the requirements of the zones shown in Table 1-1, refer to Chapter 13 of the City of San Diego Municipal Code.

1.7 REQUIRED CAPACITY IN EXISTING SEWER SYSTEMS DOWNSTREAM OF NEW FACILITIES

1.7.1 Required Capacity Downstream of New Gravity Sewers

For a new development, the projected peak wet weather flow from the proposed system (ref. Subsection 1.3.2.2) will be added to the field measured maximum flow in the downstream sewer to determine if the projected d_n/D is in compliance with the depth criterion described in Subsection 1.3.3.3. If this criterion is not met, a comprehensive sewer study of the area shall be prepared.

The downstream system shall be studied to the point in the system where the projected peak wet weather flow from the proposed new development is less than 10% of the total flow. All sewers to this point are required to carry the total flow per the depth criterion described in the above paragraph. The existing system to be studied shall not be less than two pipe reaches (i.e. manhole to manhole) from the point of discharge of the new development into the existing system.

1.7.2 Required Capacity Downstream of New Pump Stations

In developed lands, the discharge of the pump station design capacity from the proposed new development will be added to the field measured maximum flow in the existing downstream sewer to determine if the projected d_n/D will comply with the depth criteria described in Subsection 1.3.3.3. If these criteria are not met, a comprehensive sewer study of the area shall be prepared.

The sewer system downstream of the pump station shall be designed for cyclical pumping operation (i.e. on-off pumping). Use the design discharge capacity of the pump station for the tributary area. As a rule of thumb, the cyclical effect in single family residential may be considered negligible when the pump station's discharge is less than 10% of the total flow. For other density types consult with the Senior Engineer. All sewers to this point are required to carry the total flow per the depth criterion described in the above paragraph. The proposed new system shall discharge at a point not less than two pipe reaches (i.e. manhole to manhole) away the existing system.

1.7.3 **Odor Control**

The DESIGN ENGINEER shall design the wastewater system so that objectionable odors are not discharged into the atmosphere or through plumbing vents. Odors are caused by organic biologic activity and the location of the problematic area in the system is not always predictable.

The DESIGN ENGINEER shall account for the possibility of odors developing as the subdivisions build out including setting right of way aside that has good access for the locations of odor control equipment. The developer will modify the system up to one year after final occupancy of the drainage basin.

Some of the properties that impact odor may include the following:

- sewage detention times
- force main discharge points
- submerged flow at siphons
- locations with turbulent flow
- flat slopes
- type of discharge content including industrial waste discharge
- temperature and weather conditions

Odor control may include chemical injection such as calcium nitrate or other approved chemicals, or installation of an activated carbon system, or both.

1.8 **MINIMUM INTAKE STANDARDS FOR SEWER STUDIES**

At a minimum, include the following items on the exhibit and within the body of all wastewater planning studies for new sewer development projects:

- a. Internal order numbers, tentative map numbers, and any discretionary permit numbers [i.e. Conditional Use Permit (CUP), Planned Residential Development (PRD), or Planned Industrial Development (PID)].
- b. Project name.
- c. Vicinity map.
- d. Scale of sufficient size to accommodate the details required by this list. Minimum Scale will be 1 inch = 100 feet.
- e. Reference drawing numbers for existing sewer mains.
- f. Limits of the project area.

- g. Streets with names or distinguishing labels and dimensions.
- h. All existing and proposed utilities with adequate separation, whether in streets, side yards, or canyon slopes. Cross sections shall show dry and wet utilities.
- i. Existing and proposed sewer mains labeled as public or private.
- j. Deviation requests for all sewer mains which exceed standard depths.
- k. All existing and proposed “sewer access” easements. Indicate whether these will be permanent, to be abandoned after construction, or will be dedicated.
- l. Paved width of all easements and connections to streets and manholes.
- m. Typical bench section for limits of easement width and paving.
- n. Topography of the entire drainage basin and the proposed development.
- o. Elevations for existing and proposed grades throughout the project area. A reference copy of the proposed grading plans may be provided instead, if applicable.
- p. Manhole numbers and reach or pipe segment numbers for ease of comparison with the flow data in the Sewer Study Summary (Figure 1-2). Label all points of connection where project flows discharge to existing facilities and, where applicable, to the terminus of the study area. For off-site sewer mains, show information for a minimum of two reaches upstream and downstream in accordance with Subsection 1.7.1. Also identify all existing sewer mains in the Remarks column of Figure 1-2 - Sewer Study Summary.
- q. Pipes labeled with size, type, flow direction, and slope.
- r. Manholes, within the limits of the project area, shown with rim elevation and invert elevation. Note that sewer depth information is more critical where the mains are not at standard depths (refer to section 2.2.1.5), where they are located in easements, where off-site flows join the project area, or where grading is proposed over existing facilities.
- s. Number of Dwelling Units per Pipe Reach. Equivalent dwelling units per each reach shall be identified from the most upstream manhole to the downstream end of the project boundary.

- t. Land use areas labeled as single family residential, multi-family residential, commercial, industrial, schools, parks, open space, multiple habitat preservation area (MHPA), multiple species conservation program area (MSCP), stream beds or 100-year flood area.
- u. Location of all proposed pump stations. Label all pump stations as public or private. For public pump stations, show access roads and lots as dedicated in fee title to the City of San Diego. All pipe systems upstream of private pump stations shall be clearly labeled “private”.
- v. Location of any sewer facilities proposed in canyons and environmentally sensitive lands. Show any required sewer access roads in order to implement the Sewer Maintenance Plan to be developed as part of the planning study (refer to Council Policy 400-13 - ATTACHMENT 1).
- w. List any documents or studies that are incorporated by reference into the report. Do not include copies of the reports in the sewer study if they are part of the Public Utilities Department’s Library.
- x. Master plan of the project area, when requested.
- y. As-built plans of existing facilities where any point of connection is planned.
- z. Flow metering data, when requested.

**TABLE 1-1
CITY OF SAN DIEGO SEWER DESIGN GUIDE
DENSITY CONVERSIONS**

Zone	Maximum Density (DU/Net Ac)	Population per DU	Equivalent Population (Pop/Net Ac)
AR-1-1, RE-1-1	0.1	3.5	0.4
RE-1-2	0.2	3.5	0.7
AR-1-2, RE-1-3	1	3.5	3.5
RS-1-1, RS-1-8	1	3.5	3.5
RS-1-2, RS-1-9	2	3.5	7.0
RS-1-3, RS-1-10	3	3.5	10.5
RS-1-4, RS-1-11	4	3.5	14.0
RS-1-5, RS-1-12	5	3.5	17.5
RS-1-6, RS-1-13	7	3.5	24.5
RS-1-7, RS-1-14	9	3.5	31.5
RX-1-1	11	3.4	37.4
RT-1-1	12	3.3	39.6
RX-1-2, RT-1-2, RU-1-1	14	3.2	44.8
RT-1-3, RM-1-2	17	3.1	52.7
RT-1-4	20	3.0	60.0
RM-1-3	22	3.0	66.0
RM-2-4	25	3.0	75.0
RM-2-5	29	3.0	87.0
RM-2-6	35	2.8	98.0
RM-3-7, RM-5-12	43	2.6	111.8
RM-3-8	54	2.4	129.6
RM-3-9	73	2.2	160.6
RM-4-10	109	1.8	196.2
RM-4-11	218	1.5	327.0

**TABLE 1-1
CITY OF SAN DIEGO SEWER DESIGN GUIDE
DENSITY CONVERSIONS (Continued)**

Zone	Maximum Density (DU / Net Ac)	Population Per DU	Equivalent Population (Pop/Net Ac)
Schools/Public	8.9	3.5	31.2
Offices	10.9	3.5	38.2*
Commercial/Hotels	12.5	3.5	43.7*
Industrial	17.9	3.5	62.5*
Hospital	42.9	3.5	150.0*

Figures with asterisk (*) represent equivalent population per floor of the building.

Definitions:

DU = Dwelling Units

Ac = Acreage

Pop = Population

Net Acreage is the developable lot area excluding areas that are dedicated as public streets in acres. Gross Area is the entire area in acres of the drainage basin, including lots, streets, etc.

For undeveloped areas, assume Net Acreage = 0.8 x Gross Area in Acres

For developed areas, calculate actual Net Acreage.

Tabulated figures are for general case. The tabulated figures shall not be used if more accurate figures are available.

Population is based on actual equivalent dwelling units (EDU) or the maximum estimate obtained from zoning.

Conversion of Fixture Units to Equivalent Dwelling Units (EDU): The Water Meter Data Card, maintained by the Development Services Department, contains a table of plumbing fixtures that should be used for determining the equivalent dwelling units (EDU's) for the purpose of estimating the rate of wastewater generation in residential, commercial, or industrial areas. Currently, the basis for conversion is: 20 fixtures = 1 EDU and 1 EDU = 280 gallons of wastewater per day.

In high rise building areas, flow rates shall be based on the most current, adopted edition of the applicable Plumbing Code, assuming one lateral per area. The most conservative flow rate shall govern.

PUBLIC UTILITIES DEPARTMENT
PEAKING FACTOR FOR SEWER FLOWS
(Dry Weather)

Ratio of Peak to Average Flow*
Versus Tributary Population

<u>Population</u>	<u>Ratio of Peak to Average Flow</u>	<u>Population</u>	<u>Ratio of Peak to Average Flow</u>
200	4.00	4,800	2.01
500	3.00	5,000	2.00
800	2.75	5,200	1.99
900	2.60	5,500	1.97
1,000	2.50	6,000	1.95
1,100	2.47	6,200	1.94
1,200	2.45	6,400	1.93
1,300	2.43	6,900	1.91
1,400	2.40	7,300	1.90
1,500	2.38	7,500	1.89
1,600	2.36	8,100	1.87
1,700	2.34	8,400	1.86
1,750	2.33	9,100	1.84
1,800	2.32	9,600	1.83
1,850	2.31	10,000	1.82
1,900	2.30	11,500	1.80
2,000	2.29	13,000	1.78
2,150	2.27	14,500	1.76
2,225	2.25	15,000	1.75
2,300	2.24	16,000	1.74
2,375	2.23	16,700	1.73
2,425	2.22	17,400	1.72
2,500	2.21	18,000	1.71
2,600	2.20	18,900	1.70
2,625	2.19	19,800	1.69
2,675	2.18	21,500	1.68
2,775	2.17	22,600	1.67
2,850	2.16	25,000	1.65
3,000	2.14	26,500	1.64
3,100	2.13	28,000	1.63
3,200	2.12	32,000	1.61
3,500	2.10	36,000	1.59
3,600	2.09	38,000	1.58
3,700	2.08	42,000	1.57
3,800	2.07	49,000	1.55
3,900	2.06	54,000	1.54
4,000	2.05	60,000	1.53
4,200	2.04	70,000	1.52
4,400	2.03	90,000	1.51
4,600	2.02	100,000+	1.50

*Based on formula: $\text{Peak Factor} = 6.2945 \times (\text{pop})^{-0.1342}$
(Holmes & Narver, 1960)

FIGURE 1-1

SEWER STUDY SUMMARY

SHEET ___ OF ___
 DATE: _____
 REFER TO PLAN SHEET _____

WBS NO. _____

FOR: _____
 BY: _____

Line	From	To	Population Per D.U.'s	In-Line D.U.'s	Population Served		Sewage Per Capita Per Day (gpd)	Average Dry Weather Flow	Dry Weather Peaking Factor (1)	Peak Dry Weather Flow	Wet Weather Peaking Factor (2)	Peak Wet Weather Flow (Design Flow)		Line Diameter (D) (in)	Design Slope (%)	dn (ft)	dn/D	Velocity (ft/s)	Remarks		
					In-Line	Cumulative Total						mgd	cfs								

Note 1: Sewer Design Guide, Refer to Subsection 1.3.2.2 for definition of Dry Weather Peaking Factor.
 Note 2: Sewer Design Guide, Refer to Subsection 1.3.2.2 for definition of Wet Weather Peaking Factor.

**SEWER STUDY SUMMARY
 FIGURE 1-2**

CHAPTER 2 GRAVITY SEWER SYSTEM DESIGN**2.1 GENERAL**

All new development wastewater plans shall be routed through the Public Utilities Department, Water and Sewer Development Review.

Water and Sewer Development Review shall distribute plans to all parties who will be involved in subsequent review and shall consolidate comments with the following exceptions:

For projects originated by the Public Works, Engineering Division, and the Public Utilities Department, the DESIGN ENGINEER shall submit the subsequent review documents directly to the Wastewater Collection Division.

- a. For projects that will be private, the DESIGN ENGINEER shall provide subsequent review documents to the City's Development Services Department (DSD), Mechanical Plan Check Section.
- b. Geotechnical investigations shall be required for pipes 18 inches in diameter and larger, but for pipes 15 inches and smaller in diameter the requirement shall be on an as-needed basis. As a minimum, a geotechnical report shall be required for any of the following conditions: where the sewer is located at the toe of slopes, where fill is placed below the pipe, where tie back shoring will be used, where drilled or driven piles are closer than 15 feet from any sewer main, where the sewer main is within or crosses any seismic fault, or where soils are expansive.
- c. Special consideration shall be given to sewer segments which are located in fill areas or where the sewer transitions from a cut to a fill (refer to Subsections 2.2.2.3 and 2.2.3.2).

2.2 DESIGN OF SEWER MAINS**2.2.1 General Considerations****2.2.1.1 Determination of Allowable Loading**

For determining the allowable loading on sewers, the DESIGN ENGINEER shall use *ASCE Manuals and Reports on Engineering Practice - No. 60 Gravity Sanitary Sewer Design and Construction*

2.2.1.2 Design Deflection of PVC Pipes

Design deflection of a PVC pipe in any size under loads shall not exceed 5 percent with a deflection lag factor of 1.5.

2.2.1.3 Traffic Loads, Dead Loads, and Other Loads

The DESIGN ENGINEER shall pay special attention to the design of sewer pipes from the standpoint of traffic loads, dead loads, embankment loads, and other loads that the pipes may be subjected to during their design life. Pipes that are located in 100-year flood area or below the groundwater table shall be reviewed for hydrostatic uplift.

To avoid adverse effects on pavement sections, deflection of shallow mains (with less than 4 feet cover) shall be minimized by special design as required by the Senior Civil Engineer.

2.2.1.4 Concrete Encasement/Casing

- a. Special design including reinforced concrete encasement, casing/outer pipe, or a combination of these methods may be required by the Senior Civil Engineer. (Ref. Subsection 2.2.1.3).
- b. Polyvinyl chloride (PVC) pipe shall not be used with concrete encasement or concrete cradle.
- c. Reinforced concrete encasement may be required where landscaping may cause root intrusion.
- d. Only extra strength vitrified clay pipe or ductile iron pipe shall be used with concrete encasement. However, this does not preclude the placement of “lean” concrete backfill above the limits of the rock envelope when using PVC pipe.

2.2.1.5 Depth of Mains

- a. **Cover** is defined as the vertical distance from the finished grade to the top of the sewer main. **Depth** is defined as the distance between invert and finished grade of the sewer main.
- b. Sewer pipes shall be designed to achieve a cover of 7 to 9 feet wherever possible.
- c. Mains with a depth of 15 feet or greater shall require a Design Deviation Request (ATTACHMENT 2) submitted for approval by the Senior Civil Engineer.
- d. In addition, mains deeper than 20 feet, or mains 15 feet deep with laterals, shall require special approval from the Public Utilities Department, Wastewater Collection Division Senior Civil Engineer.

- e. Design Deviations for depth will only be approved in exceptional cases and when adequate justification is provided.
- f. No lateral connections will be allowed on mains that exceed 15 feet in depth. In those cases where mains are permitted to exceed 15 feet in depth, and lateral connections are necessary, a parallel collector sewer shall be required at standard depths to serve the lots.
- g. In open space areas, the standard depth of mains shall be 4 to 5 feet, assuming there are no lateral connections, or as topography allows. Where lateral connections are necessary, the main depth shall be as necessary to accommodate the lateral depths and the contours of the land. The DESIGN ENGINEER shall provide sufficient depth and/or special design at stream bed crossings and other locations to assure protection from erosion.
- h. Where a future building will be located adjacent to a new main, the depth of the main shall be coordinated with other utilities so that there will be no conflicts with the future sewer lateral.

2.2.1.6 **Shallow Mains**

Shallow mains require special designs (refer to Subsection 1.4.2.1). For mains with less than 4 feet of cover, special design shall be required for dead load and linear deflections which shall include evaluation of pavement section deflections.

Lined and coated ductile iron pipe or steel pipe may be used in shallow applications. If concrete encasement is not required for structural purposes, pipe corrosion prevention requirements shall apply. Refer to Chapter 6 - Corrosion Control, for pipe lining and coating requirements.

2.2.1.7 **Depth of Dead-End Mains**

Dead-end mains with the potential for future extension shall not be less than 7 feet in depth at the dead-end, and shall not preclude any property in the upstream basin from obtaining sewer service. Deviations from such criteria shall require approval by the Senior Civil Engineer. Grades shall be as uniform as practical. For manhole requirements at dead-end mains, refer to Subsection 2.3.1.6.

2.2.1.8 **Redundant Sewers**

Redundancy in the sewer system shall be provided if a sewer would be located where it would preclude by-pass pumping in the event of a main failure or stoppage. Examples would be where a sewer crosses railroad tracks that

cannot be taken out of service, or in a Caltrans right-of-way where there is no nearby local traffic bridge that can be used for the bypass. In such cases, an empty encased concrete or steel sleeve must be provided parallel to the sewer to the manhole on either side of the obstruction. A nearby parallel storm drain may also be used for this purpose if there is excess capacity to accommodate the by-pass high line, and where velocities in the storm drain are less than 4 feet per second during a storm event.

2.2.2 Sewer Mains 15-inch and Smaller in Diameter

2.2.2.1 Minimum Depths

New sewer mains shall be designed with minimum depths to provide at least a sewer lateral depth of 5 feet at the property line (refer to City of San Diego Standard Drawings SDS-100 and SDS-105. Lateral depth requirements shall be considered in sewer replacement projects.

2.2.2.2 Changes in Direction

- a. Changes in direction shall occur only in a manhole.
- b. To maintain laminar flow and minimize head losses through the manhole, the maximum horizontal change in the direction of flow for sewer mains 15-inch or smaller shall be 90 degrees.
- c. Where there is a side inlet, the angle between the two mains entering the manhole shall be 90 degrees or less.

2.2.2.3 Requirements for Depths Greater Than 15 Feet

For mains 15 inch in diameter and smaller and at depths less than 20 feet, the DESIGN ENGINEER may use City of San Diego Drawing SDS-101 for PVC pipes. A soils report shall be required for pipes deeper than 15 feet to verify the assumptions made in Note 1 of SDS-101. A geotechnical report and settlement calculations are required in such cases in order to account for any potential for differential settlement or other settlement that may detrimentally affect the pipe slope. For mains 15 inch in diameter and smaller and at depths between 15 feet and 20 feet, the DESIGN ENGINEER may use SDR 18 PVC pipe in lieu of a soils report to substantiate the standard assumption given in Note 1 of SDS-101 (Refer to Subsection 2.2.1.5 above for conditions requiring a design deviation request).

2.2.3 Sewer Mains 18-inch and Larger in Diameter (Trunk Sewers)

2.2.3.1 Changes in Direction

- a. Changes in direction shall occur only in a manhole, vault, or junction structure.

- b. The maximum horizontal change in the direction of the flow shall be 45 degrees in order to maintain laminar flow, and to minimize head losses, standing waves, and odors. In other words, the minimum angle between the two mains shall be 135 degrees.

Where there is a side inlet, the angle between the two mains entering the manhole shall be 45 degrees or less.

- c. Criteria for determining the height of the manhole shelf to accommodate the standing wave can be found in Subsection 2.3.3.
- d. Sewers 27-inch in diameter and greater shall require special design for changes in direction to assure laminar flow.

2.2.3.2 **Allowable Loading**

For determining allowable loading on pipes of 18 inches in diameter or larger, design assumptions shall be verified and pipe loading and bedding calculations shall be required. A geotechnical report and settlement calculations shall be required in such cases in order to account for any potential for differential settlement or other settlement that may detrimentally affect the pipe slope. All requirements of City of San Diego Drawing SDS-101 shall be adhered to as a minimum when PVC pipe is used. All calculations, soil reports, and a geotechnical report for the sewer design shall be submitted for approval by the City.

2.2.3.3 **Shop Drawing/Material Submittal Requirements**

For PVC-lined concrete pipe (steel cylinder with “Carnegie” joint typically will be required), shop drawings shall be submitted to the Senior Civil Engineer for approval at least ten weeks prior to fabrication. For vitrified clay and PVC-lined concrete pipe, material sample submittals shall be submitted to the Senior Civil Engineer for approval at least ten weeks prior to fabrication. A list of shop drawings and submittal requirements shall be clearly defined on the plans.

2.2.3.4 **Trench Details**

Trench details shall be shown on the plans for all sewer mains 18-inch in diameter and larger.

2.2.4 **Hydraulic Jumps**

Hydraulic jumps (in order of preference) shall be:

- a. Avoided

- b. Minimized
- c. Located in a pipe upstream of the manhole
- d. Located in a manhole

The DESIGN ENGINEER shall use a vertical curve upstream of a manhole before it reaches the manhole to provide a gradual transition from supercritical flow (flow at a depth less than critical) to sub-critical flow (flow at a depth greater than critical). The flow surface at the jump within a vertical curve shall not exceed the d_n/D ratio of 0.50 for all pipe diameters in accordance with Subsection 1.3.3.3.

For pipe diameters of 24-inch and less, the height of any hydraulic jump shall not exceed 20 percent of the pipe diameter ($d_{n2} - d_{n1} \leq 0.2D$). For diameters larger than 24-inch, any hydraulic jump requires review and approval by the Senior Civil Engineer (Refer to Subsection 2.3.5.3.d).

2.2.5 Alignment of Sewers

- 2.2.5.1 Sewers designed to serve properties on both sides of a street shall be located along the centerline of the street according to SDRSD M-22 and City of San Diego Drawing SDM-111.
- 2.2.5.2 If the sewer will serve properties on one side of a street only, it may be located on that side of the street if no potential conflict with other utilities exists. If there will be or could be a raised median, the sewer shall be located on the north or west side of the street a minimum of 5 feet from the median face of curb, but shall be a minimum horizontal distance of 10 feet from any trees or shrubs that are 3 feet or taller at maturity. In such cases, the sewer shall be located in the center of the number one traffic lane or directly in between the number one and number two lanes, under the lane striping.
- 2.2.5.3 The minimum distance from the face of a sewer main or a manhole to the edge of any street pavement shall be 10 feet, based on the depth of mains defined in Subsection 2.2.1.5.b, to prevent possible flooding over the manhole cover. In exceptional cases, where the sewer must be located less than 10 feet from the edge of pavement, a request for design deviation must be submitted (ATTACHMENT 2) and approval by the Senior Civil Engineer is required. If a deviation is allowed, pipe upgrades, such as provision of a pipe sleeve, shall be required to meet the intent of eliminating root intrusion from sewers.
- 2.2.5.4 If the sewer will be located in a canyon area, the mains shall be located a minimum of 30 feet from any riparian trees.
- 2.2.5.5 Sewer mains shall not be placed in areas of erosion or where the area over the main will receive storm flows such as from a side canyon or storm drain outlet. Cross gutters may be used where the flow during a 100-year storm

event is assumed not to exceed 9 inches and where the velocity is assumed not to be problematic for maintenance vehicles. The entire flow must be contained in the cross gutter and shall be designed with appropriate rip-rap, gabions or other erosion control features. As an alternative, the flow may be contained in an under-drain, with appropriately designed head wall and end wall and energy dissipaters.

- 2.2.5.6 In accordance with the City of San Diego Street Design Manual, all site grading must be directed to streets where there is curb and gutter to carry storm flows. Alleys that take drainage from the surrounding properties are inappropriate for locating sewer mains, unless it can be demonstrated that the 100-year storm event flows will not flow over the manhole covers (refer to Subsection 2.3.1.2.b). In some cases, it may be reasonable to intercept storm flows on private property. The private storm drain system shall be maintained by a business owners association.
- 2.2.5.7 In alleys or private driveways with an alley type section, the sewer main shall be located north and/or west of the centerline when there is also an existing or proposed water main in the roadway section. Otherwise, sewer mains shall be located on the centerline. Utility spacing shall be per SDRSD M-22.
- 2.2.5.8 The sewer main shall be maintained a minimum of 10 feet from the edge of paving and 15 feet from structures. The City of San Diego Street Design Manual calls for 5 foot setbacks for buildings adjacent to alleys.
- 2.2.5.9 In special cases where the owner desires to reduce the 15-foot setback from structures, the distance between the building and the sewer may be reduced to a minimum face-to-face distance of 10 feet. In such cases, deep foundations and a special building permit will be required. The DESIGN ENGINEER shall contact the Public Utilities Department, Water and Sewer Development Review, for consultation. A cross section drawing and soils report shall be submitted. If approved, a design deviation request shall be processed.
- 2.2.5.10 Minimum distance between the facing edges of proposed sewers and parallel existing utilities shall be at least 10 feet. Review and written approval shall be required from the State of California Department of Public Health, Drinking Water Field Operations Branch, for separation deviations between water, sewer or reclaimed water.

2.2.6 **Utility Crossings**

Long skew crossings under existing or proposed substructures and utilities shall be avoided. Sewers shall cross substructures and utilities as close to perpendicular as possible. Skew angles of less than 75 degrees shall be avoided and shall require a request for design deviation (ATTACHMENT 2) and approval by the Senior Civil Engineer.

2.2.7 Profile of Sewers

The profiles for pipes 18 inches in diameter and larger shall show the invert and top of pipe elevations, and they shall include the following information for each section of pipe. This information shall be shown for both the calculated peak dry weather flow and approved peak wet weather flow to be used in the design of the sewer (refer to Subsection 1.3.2.2 above).

- Q = Design discharge in million gallons per day
- V = Design velocity in feet per second
- D = Inside diameter of pipe in inches
- d_n = Depth of design flow in inches
- d_n/D = Ratio of depth at design flow divided by the pipe diameter
- n = Manning's "n" (0.013).

Sewer main profiles shall be designed to provide a minimum velocity of 2 fps and maximum velocity of 10 fps. (Ref. Subsection 1.3.3.1)

2.2.8 Cutoff Walls

In unpaved areas with steep terrain, pipes and pipe bedding shall be protected by cutoff walls per SDS-115, Type A. In paved areas with steep terrain, pipe shall be protected by concrete anchors per SDS-114.

Required intervals for cutoff walls and concrete anchors shall be as shown in Table 2-1.

**TABLE 2-1
INTERVAL OF CUTOFF WALLS OR CONCRETE ANCHORS**

Slope (%)	Interval of Cutoff Walls or Concrete Anchors (Feet)
20 - 35	50
35 – 45	40
45 – 55	30
55 – 65	20
65 - 100	20 with cement treated sand encasement around the pipe
Over 100	Special Design

In areas requiring cutoff walls, a geotextile fabric shall be placed around the pipe bedding to prevent erosion of fine soil particles from the bedding material.

2.2.9 Curvatures

Sewer mains may be constructed along curves provided that the curve radius can accommodate standard pipe lengths and provided that the construction meets the pipe manufacturers' recommendations and the requirements of this Section. Manholes may be located off the centerline of residential streets around street curves provided that all portions of the main and manholes are at a minimum of 10 feet from the curb.

The minimum allowable radius of curvature is governed by the type of joint, the pipe lengths, the maximum bevel permitted, and the maximum amount of separation of the abutting pipe ends permitted on the outside surface of the curved sewer. This separation of pipe ends on the outside surface of the sewer is termed the "pull" and the joint is called a "pull joint".

2.2.9.1 Curvature in Rigid Pipes

Most restrained joints provide no joint deflection. Where joint deflections are desired using restrained joints, manufacturer's specifications must be submitted for approval by the Senior Civil Engineer. Flexible joints (gasket type) allow joint deflection.

- a. **Curvature in Vitrified Clay Pipe:** Curvature in vitrified clay pipe shall be accommodated through joint deflection and shortened lengths of pipe and shall conform to Table 2-2.

**TABLE 2-2
RADIUS OF CURVATURE FOR PIPE DEFLECTION**

Nominal Pipe Diameter (inches)	Minimum Radius of Curvature R (Feet) For Pipe Length, L (Feet)			
	L = 4	L=6	L = 8	L = 10
3 to 12	200	200	200	200
15 to 24	200	200	256	320
27 to 36	200	288	384	480
39 to 42	256	384	512	640

- b. **Curvature in Other Rigid Pipes:** Curvature in other rigid pipes shall be accommodated solely through joint deflection per the manufacturer's recommendations or through custom beveled ends. Axial bending shall not be allowed.

The following joint deflection equation shall be used to determine the minimum radius of curvature for rigid pipes with unrestrained joints:

$$R = \left[\frac{360^0}{\Delta} \times \frac{L}{2\pi} \right] \text{ or } 200 \text{ feet, whichever is greater}$$

Where:

R = minimum radius of curvature, in feet

L = length of pipe section

Δ = allowable deflection per joint in degrees (See Figure 2-2)

2.2.9.2 Curvature in Flexible Pipes

- a. **Longitudinal Bending (Up to 15 Inch Diameter Pipe):** Bending of flexible pipes with gasket type joints is allowed through a combination of joint deflection and axial flexure of the pipe (see Figure 2-2). The allowable deflection per joint for gasket type PVC pipe varies from 1/3 to 5 degrees (obtain joint deflection limits from the pipe manufacturer). Typical minimum allowable values of radius of curvature for flexible pipes are given in Table 2-3.

**TABLE 2-3
MINIMUM ALLOWABLE RADIUS OF CURVATURE**

Allowable Minimum Radius of Curvature (Longitudinal Bending) With 2° Joint Deflection	
Pipe Size (in inches)	Radius (in feet)
4 to 8	200
10	250
12	300
15	350

The equations in Figure 2-2 may be used to determine bending and deflection for other types of flexible pipe.

2.2.9.3 Horizontal Curvature

The minimum radius of horizontal curvature shall be 200 feet unless otherwise approved by the Senior Civil Engineer.

Where curves of shorter radii than those accommodating standard pipe lengths are necessary, shorter lengths of pipe and/or custom beveled joints may be used for concrete and VC mains.

When PVC lined reinforced concrete pipe is to be laid along curves, the shop drawings shall include pipe manufacturer's joint information (gaskets, bell and spigot details), specified pull at each joint, bevel details, and any pipe design special details.

2.2.9.4 Vertical Curvature

- a. Vertical curves shall not be located within the limits of horizontal curves except as may be approved by the Senior Civil Engineer.
- b. The minimum horizontal length of vertical curves may be computed as follows, but shall not be less than 40 feet:

$$L = (S_1 - S_2) / R$$

Where:

- L = Minimum horizontal length of vertical curve (≥ 40 feet)
- S_1 & S_2 = Slopes of beginning and ending tangents to the vertical curve expressed in feet per foot, and
- R = Minimum rate of change of slope (feet/foot), as determined by the pipe manufacturer's specifications

Vertical curves on sewers shall be parabolic in nature.

For manhole requirements on vertical curves, refer to Section 2.3.

2.2.10 Prohibited Locations

Construction of sewer mains shall be prohibited in any of the following locations:

- a. Within the 100-year flood areas or coastal areas subject to flooding
- b. Within wetlands
- c. Parallel to major highways/freeways (perpendicular crossings only)
- d. Under structures
- e. Within 10 feet of trees or shrubs that mature naturally to a height of over 3 feet
- f. Within medians
- g. Parallel to railroad alignments unless a separate easement is acquired
- h. Inaccessible areas
- i. Within 10 feet of any structure
- j. Near the outlet of any storm drain

- k. In open space, canyons and sensitive lands (refer to Subsection 3.2.3.4)
- l. Near the top of coastal bluffs or steep slopes

2.2.11 Main Extensions

In existing communities, where a main is being extended that will eventually serve other lots, the main shall be designed to accommodate ultimate build out.

Duplexes and high density residential units shall be required to extend the main to their frontage if there is a possibility of further main extension or there are other lots that could connect to the new main at a later date. See Subsection 2.5.12.

2.3 MANHOLES

2.3.1 General Design Considerations

All manholes shall be constructed in accordance with City of San Diego Standard Drawings SDS-100, SDS-106, and SDS-107.

Invert elevations within the manhole of both the inlet and outlet pipes and the rim elevation of each manhole shall be shown on the plans.

Rungs or ladders are not allowed in manholes.
Drop manholes are not allowed.

2.3.1.1 Required Locations

A manhole shall be required at any of the following locations:

- a. Change of grade
- b. Change in pipe size
- c. At the beginning point and ending point of vertical curves if the curve is longer than 200 feet, or 25 feet downstream from the end of a vertical curve if the curve is less than 200 feet
- d. At the intersection of mains
- e. At the terminus of dead-end sewers
- f. Change in pipe material*
- g. Change of flow direction
- h. At the discharge of a private pump station force main, the DESIGN ENGINEER shall provide a dedicated manhole prior to discharge to the public system

2.3.1.2 Prohibited Locations

Manholes shall not be placed in any of the following locations:

* Internal diameters of pipes of different materials, although specified as the same size, are not the same and a smooth transition within the manhole must be provided between all changes in pipe material.

- a. Inaccessible area
- b. Any area subject to flooding during a 100-year storm event such as a gutter, cross gutter, brow ditch, alley or localized depression
- c. In sidewalks, crosswalks, or pedestrian ramps
- d. In driveways
- e. In freeway ramps or lanes
- f. Between railroad tracks (manholes within a railroad right-of-way shall be located a minimum of 15 feet from track bed and in accordance with the requirements of the jurisdictional railroad authority)
- g. Within 15 feet of any structure, including subterranean or overhead structures

2.3.1.3 Manholes at Street Intersections

Where a new or reconstructed sewer main passes through a manhole in a street intersection and the manhole has no side inlet or future planned connecting main, the manhole shall be located approximately 30 feet either downstream or upstream of the intersection. Contact the Public Utilities Department, Water and Sewer Development Review, to research the probable need for future sewer connections. This manhole location will afford improved maintenance access and easier traffic control for construction/cleaning crews in high traffic streets.

2.3.1.4 Manholes Outside Public Right-of-Way

All sewer manholes outside the paved right-of-way shall have adequate vehicular access for sewer maintenance vehicles per Subsections 3.2.1.3 and 3.2.3.

All manholes located outside of the public right-of-way shall be equipped with approved locking covers with concrete collars as indicated on SDM-113 or as specified by the Wastewater Collection Division of the Public Utilities Department. Special details may be required based on operation and maintenance requirements.

2.3.1.5 Potential Hydraulic Jumps

Where change in grade of the inlet and outlet pipes is greater than 10 percent, or the potential for a hydraulic jump within a manhole exists, the grade change shall be made in a smooth vertical curve, upstream of the manhole, with the manhole located 25 feet downstream of the lower end of the vertical curve. Refer to Subsection 2.2.4 for requirements regarding hydraulic jumps.

2.3.1.6 Cul-De-Sac and Dead End Mains

- a. Mains that terminate in a cul-de-sac shall end at a manhole which shall be located 15 feet from the curb at the end of the street.

- b. Where an existing main is replaced by a City contract and it terminates in a dead end street, such as in Subsection 2.5.12, the main shall be extended and standard laterals shall be constructed perpendicular to the main.

2.3.2 Distance between Manholes

The maximum distance between manholes shall not be greater than those shown in Table 2-4.

**TABLE 2-4
DISTANCE BETWEEN MANHOLES**

Sewer Size (Inches)	Maximum Distance Between Manholes (Feet)
8 - 15	400
18 and over	800

2.3.3 Design of Manhole Shelves

- a. **Shelf Width:** The width of the shelf in manholes shall be of approximately equal size on either side of the main channel and a minimum distance of 18 inches from the edge of the channel to the manhole wall. The shelf provides a working platform for sewer maintenance personnel (see SDS-106 and SDS-107). In manholes with changes in direction of sewer flow or a side inlet, the outboard shelf may be reduced to 12 inches (moving the pipe out of the centerline of the manhole) where a long transition is needed to maintain laminar flow or to reduce the standing wave. In no case will the manhole size be reduced. The manhole may be increased in diameter or a vault may be used to increase the flow curve radius.
- b. **Outboard Shelf (Standing Wave)** Manhole bases that accommodate a change in direction of flow shall be designed with sufficient freeboard on the "outboard shelf" to keep the entire flow cross-section within the manhole channel without spillage onto the "outboard shelf". The shelf elevations shall be shown on the plans and shall be of equal height on both sides of the channel. The following formula shall be used to determine the minimum required shelf elevations:

$$\text{Therefore: } \Delta D = \frac{V^2 B}{gr} + 0.25$$

$$D_{sw} = D_N + \Delta D$$

(Reference: Brater and King, "Handbook of Hydraulics")

Where:

ΔD = Depth of outboard water surface crest above normal depth at peak flow (feet)

V = Velocity (feet per second)

B = Width (feet) of water surface (horizontal projection)

g = Gravitational constant (32.2 feet/second²)

r = Radius of bend (feet)

D_{sw} = Depth of water surface above invert (standing wave)* (feet)

D_N = Normal depth at peak flow (feet)

$$D_{sw \text{ max.}} = \frac{3}{4}d$$

d = Pipe diameter (feet)

2.3.4 Manhole Frames and Covers

Manhole frames and covers shall be non-rocking and shall conform to the requirements of ASTM A48, Class 30. Unless otherwise indicated, manhole frames and covers shall be heavy-duty cast-iron type with a 36-inch opening. Manhole cover inserts shall be 24-inch diameter with lettering "CITY OF SAN DIEGO" and "SEWER" similar to what is indicated on SDRSD M-1.

2.3.5 Manhole Lining and Grouting

2.3.5.1 Bases

Bases shall be coated for all conditions listed in Subsection 2.3.5.3. The manhole base shall be primed with epoxy and lined with a 100-mil dry film thickness (DFT) of 100 percent solids elastomeric polyurethane with a minimum, Shore D, hardness of 55 in accordance with *SSPWC Section 500-2.4 — Air-Placed Concrete and Polyurethane Protective Lining Manhole Rehabilitation*, or other methods and materials included in the City's Approved Materials List for municipal sewer applications. The lining shall be continuous, without seams, and free from any defects, holes, or surface irregularities. The CONTRACTOR shall furnish a minimum of two plugs per manhole to permit verification of the applied thickness.

2.3.5.2 Riser Joints

Polymer mortar shall be used for riser joints on manholes to create water-tight joints to prevent or minimize infiltration.

* Determination of the location of the standing wave is not required since the shelf is horizontal.

2.3.5.3 Risers

Manhole risers in the wastewater collection system shall be epoxy-grouted and lined with PVC, (or T-Lock, or other methods and materials included in the City's Approved Materials List for municipal sewer applications) in any of the following cases (See Figure 2-3 for typical application.):

- a. Manholes for all trunk sewers 18-inch and larger in diameter
- b. Manholes in all coastal communities
- c. At locations of force main discharge
- d. Manholes where high concentrations of hydrogen sulfide exist, (e.g. sealed manholes in canyons, manholes in areas downstream of sewer pump stations, manholes downstream of hydraulic jumps where the sewage is more than 4 hours old from the farthest source, and manholes upstream from siphons)
- e. Manholes where groundwater is present

2.3.5.4 Exterior Walls

Waterproofing of the exterior walls with a coal tar emulsion (waterproofing agent) shall be required for all manholes in canyons, below the water table, in coastal communities, with base elevations less than mean sea level plus seven (MSL + 7) feet, or in soils with elevated chloride ion (>300 ppm) or sulfate ion (>2,000 ppm) concentrations. The coal tar emulsion shall be applied in no less than two coats for a total dry film thickness of 25 to 35 mils.

2.3.6 Minimum Invert Drop Across a Manhole

The invert drop across a manhole or transition structure shall be calculated to provide smooth laminar flow through the manhole and shall not be arbitrarily established.

2.3.6.1 Manholes With The Same Inlet And Outlet Diameter

Manholes shall be hydraulically designed to prevent head losses through the manhole such that solids do not fall out of suspension and accumulate in the main downstream of the manhole. Mains of any size that have a peak wet weather flow below the spring-line will not be affected by the flow changing from a "U" channel back into a circular pipe.

- a. **Straight-Through Flow for Trunk Sewers with Velocity ≥ 3 fps and All Small Diameter Mains:** For trunk sewers, where the peak design velocity is 3 fps or greater, and for all small diameter mains, the slope of the pipe shall be carried through the manhole, provided the wet-weather flow d/D is 0.4 or less.

- b. **Straight-Through Flow for Trunk Sewers with Velocity < 3 fps:** For sewers 18-inch and larger in diameter with peak design velocity less than 3 fps, the invert drop across the manhole shall be equal to the inside diameter (D) of the manhole in feet multiplied by the average slope of the inlet (s_1) or outlet (s_2) sewers. However, a minimum invert drop of 0.1 feet shall be required:

$$\text{Invert Drop} = \left[D \times \left(\frac{s_1 + s_2}{2} \right) \right] \geq 0.1 \text{ ft}$$

- c. **Side Inlet for All Pipe Sizes:** The invert drop across the manhole shall be the inside diameter (D) of the manhole in feet multiplied by the average slope of the side inlet (s_1) and outlet (s_2) sewers, plus 0.10 feet of additional drop. However, a minimum invert drop of 0.20 feet shall be required:

$$\text{Invert Drop} = \left[D \times \left(\frac{s_1 + s_2}{2} \right) + 0.1 \right] \geq 0.2 \text{ ft}$$

- d. **Changes in Direction:** Same requirements as for side inlets unless the standing wave is below the spring-line in peak wet weather flow conditions, in which case the slope of the pipe shall be carried through the manhole. Also see Subsection 2.2.2.2 for more information.

2.3.6.2 Outlet Pipe Larger Than Inlet (See Figure 2-5)

When the outlet pipe is larger than the inlet pipe, the same calculations as shown above in Subsection 2.3.6.1(a) or (b) shall be used, and the drop shown in Table 2-5 shall be added to the result of each calculation.

Table 2-5 is based on matched water surface profile from the upstream pipe to the downstream pipe when flowing $\frac{1}{2}$ full. The Table may be used in lieu of calculating invert drops across a manhole due to the change in pipe diameter. However, if the sewer main is in an area where the slopes are flat, individual invert drops may be calculated based on the planning study design d_n/D at peak flow.

**TABLE 2-5
INVERT DROPS ACROSS MANHOLES**

Diameter of Outlet (inches)	Diameter of Inlet (inches) Inlet Drop to be added (feet)		
	8	10	12
10	0.08	-	-
12	0.17	0.08	-
15	0.29	0.21	0.13
18	0.42	0.33	0.25

Outlet pipes smaller in diameter than the inlet pipe shall not be allowed. In lieu of calculating the drop through a manhole, where there are good slopes and proper manhole channelization, the crown of the pipes may be matched.

2.3.7 **Maximum Invert Drop across Manhole**

Maximum invert drop across a manhole for sewers 15- inch in diameter and smaller shall be 0.60 feet for straight through flow and 1.00 feet for side inlet flow.

2.3.8 **Minimum Manhole Size**

The minimum manhole base diameter shall be 4 feet per SDS-107, but not less than the pipe diameter plus 3 feet.

2.3.9 **Large Diameter Manholes**

For sewer mains greater than 36 inches in diameter, special design and structural details for the manholes or vaults shall be shown on the plans. Vaults shall require a minimum of two access manholes. A separate structural permit is required.

2.3.10 **Deep Manholes**

For sewer mains that exceed 25 feet in depth, vaults shall be provided with a minimum of two access manholes each. Calculations shall be provided to show that the vault structure is designed to accommodate the design depth. A separate structural permit is required.

2.3.11 **Inspection of Existing Manholes**

Removal of existing City manhole covers by unauthorized personnel is not permitted as potentially lethal, poisonous, or explosive gases may be present. If access to any existing City manhole is necessary for design or construction purposes, please contact the Public Utilities Department, Wastewater Collection Division at (858) 654-4154.

2.3.12 **Raising Manhole Covers**

The maximum depth of rings above the cone per SDRSD SDS-106 and SDS-107 is 18 inches. If there is a fill placed near an existing manhole, the distance above the cone can be increased to a maximum of 18 inches. Greater fill shall require that the cone be removed and the riser extended as needed to conform to the standard drawing.

2.4 **PIPE BEDDING**

2.4.1 **Normal Bedding Requirements**

Normal bedding is full rock encasement. All sewers, including laterals with normal cover, shall be adequately bedded according to City of San Diego Drawings SDS-100 and SDS-110(C). The induced trench method of construction in which the trench is excavated in compacted fill and refilled with loose compressible materials shall not be allowed.

2.4.2 **Special Considerations**

Where the possibility exists for erosion, migration, separation, or segregation of sands, silts and clay from the trench wall into the pipe bedding or where the sewer pipe is installed below the water table, the rock envelope shall be wrapped with an engineering geotextile fabric.

2.4.3 **Load Factors for Clay Pipe**

Vitrified clay pipe shall be bedded based on the calculated loads and a safety factor of 1.5. Bedding should be selected based on a load factor of 2.2 for rock encasement and a load factor of 4.5 for concrete encasement.

2.5 SEWER LATERALS

2.5.1 Allowable Locations

- a. All new sewer laterals shall not be located in or within 5 feet of driveways unless no other alternative exists. If the lateral already exists, or sufficient area is not available to locate the lateral outside of the driveway due to cul-de-sacs, trees, etc., the installation shall be according to Figure 2-6, which shall be included on the improvement plans.
- b. All laterals located in or within 3 feet of driveways shall be shown as private on the public improvement drawings and shall require an Encroachment Maintenance and Removal Agreement (EMRA).
- c. Laterals cannot be located in the same trench as other utilities. A minimum of 3 feet, edge to edge, horizontal separation between sewer laterals and any other dry utilities is required.
- d. Laterals shall not be located within 5 feet of water meters. Sewer laterals shall be a minimum of 5 feet apart (center to center), and located at least 5 feet downhill from the water service.
- e. For large structures (minimum 250 feet of building frontage), two lateral connections to the public system are allowed. Where needed, additional private laterals may be allowed provided it can be shown that the entire project flow can be served by 2 laterals that are sized per the Uniform Plumbing Code, and which also do not exceed connection limitations per the Sewer Design Guide, Table 2-6.
- f. Where the sewer main is located in an easement with no drivable access or in a paper alley or street, new laterals shall not be connected unless there are no alternative sewer facilities.
- g. Sewer laterals shall not cross lot lines unless there are no other reasonable options. A private easement shall be dedicated to the lot benefiting from the lateral.

2.5.2 Depth Requirements

Sewer laterals shall be at a minimum of 5 feet and a maximum of 7 feet below top of curb, measured at the property line (City of San Diego Drawings SDS-100, SDS-105, and UPC). Shallow laterals between 3 feet and 5 feet in depth may be allowed with special design and approval by the Associate Civil Engineer in Water and Sewer Development Review, Public Utilities

Department. When special circumstances dictate that the cover over a lateral must be less than 3 feet, the lateral should be fully encased in concrete (See SDS-112), using only extra strength vitrified clay pipe or with concrete encased or epoxy coated ductile iron pipe. Loading and deflection calculations must be submitted and approved by the Senior Civil Engineer. Polyvinyl chloride (PVC) pipes shall not be used with concrete encasement. Only extra strength vitrified clay pipe or ductile iron pipe shall be used with concrete encasement.

Lateral connections to deep sewers (depth greater than 15 feet) shall be avoided wherever possible. No lateral connections will be allowed on mains which exceed 20 feet in depth (Refer to 2.2.1.5).

2.5.3 **Slope**

The standard minimum slope for a sewer lateral is 2 percent (SDS-105 and UPC). The slope shall not exceed 1 vertical to 1 horizontal ratio (100 percent). Laterals which must exceed 100 percent slope within the public right-of-way shall be considered as deep-cut laterals. Deep-cut laterals shall only be permitted with the approval of the Senior Civil Engineer. The DESIGN ENGINEER shall submit justifications using a Design Deviation Request Form (ATTACHMENT 2) and details that show all bends with a custom fabricated sweep, having a minimum 3 foot radius.

2.5.4 **Cleanouts**

All public laterals shall have a cleanout adjacent to the property line, within the public right-of-way, for cleaning in the direction of the sewer main. The cleanout shall be installed in accordance with City of San Diego Drawings SDS-102 or SDS-103. If there is a sidewalk located at the property line, the cleanout shall be located in the sidewalk in accordance with SDS-102. In special cases, the cleanout may be located up to 3 feet behind the property line to avoid conflicts with surface improvements.

For CIP construction and City Force work, when constructing or reconstructing laterals as part of a CIP or emergency lateral replacement, all public laterals shall be provided with a cleanout (even those that are not being replaced). In rehabilitation (lining) projects, only those laterals that require open cut replacement will be provided with a cleanout.

2.5.5 **Bedding**

Sewer laterals shall be bedded in accordance with SDS-110(C).

2.5.6 **Backwater Devices**

Sewer laterals shall be equipped with an approved backwater device at all locations where dictated by the currently adopted edition of the Uniform

Plumbing Code to prevent public sewage from spilling into structures if the sewer main should fail. The engineer shall design the system to insure the main spills at a manhole which shall take into the consideration the weight of the manhole cover and if the cover is bolted. Backwater devices shall be installed outside of the public right-of-way and shall be maintained by the property owner.

2.5.7 Pressure Laterals

A pressure lateral is a pipe under pressure carrying a discharge from a property sewage pump. Pressure laterals shall not be smaller than 2 inches in diameter. If there is a cleanout at the property line with a gravity lateral to the main and the discharge head of the pump results in open channel flow, it will not be construed to be a pressure lateral. Pressure laterals shall discharge into a manhole which shall be lined with PVC (e.g., T-lock), or other methods and materials included in the City’s Approved Materials List for municipal sewer applications. See Figure 2-3 for typical application. All manholes into which pressure laterals discharge shall be clearly labeled as such on the public improvement plans. All pressure laterals shall be equipped with a check valve. When a pressure lateral terminates at the property line with a cleanout and becomes a gravity lateral, then the gravity lateral portion should comply with gravity lateral requirements.

For a pressure lateral connection to a trunk sewer, see Subsection 2.5.9.

2.5.8 Connections to Existing Mains

2.5.8.1 Required Location of Connections

Sewer lateral connections shall be made in accordance with Table 2-6:

**TABLE 2-6
SEWER LATERAL CONNECTIONS**

Size/Type of Lateral	Size of Main	Connection Made At
6" or smaller	15" or smaller	Main
Same as main	Same as lateral	Manhole
8" or larger	15" or smaller	Manhole
Pressure Lateral	Any Size	Manhole

Note: At no time shall the main be smaller than the lateral.

2.5.8.2 Allowable Types of Connections

Lateral connections to existing sewer lines may only be made through a “Y” fitting or saddle-type connection. Cutting or breaking out an opening for lateral connection and sealing the opening with a concrete lug shall not be allowed.

2.5.8.3 Size of Connections

Connection of a sewer lateral into an existing sewer main shall be at least 2 inches less than the diameter of the sewer main. However, 6-inch and 8-inch diameter laterals may connect into a sewer main of the same size provided that the connection is made through a “Y” fitting. The "Y" branch of the sewer main is to be inclined upward at a maximum angle of 45 degrees from the horizontal and connected to the lateral through a 1/8 bend (Ref. City of San Diego Drawings SDS-100 and SDS-105).

2.5.8.4 Required Rise from Main

The vertical distance between the invert of the sewer main at the "Y" location and the invert of the upper end of the 1/8 bend is termed the "rise". Minimum values for the rise versus various sewer main sizes are given in Table 2-7.

TABLE 2-7

MINIMUM RISE FROM SEWER MAINS

Sewer Main Size (Inches)	Minimum Rise (Feet)
8	1.2
10	1.3
12	1.4
15	1.8

In determining the slope of the sewer lateral, it may be assumed that the 1/8 bend terminates 2.0 feet laterally from the center of an 8-inch diameter sewer main.

2.5.9 Connections to Trunk Sewers

- a. Sewer lateral connections to trunk sewers 18 inches in diameter and larger shall not be allowed. Sewer laterals shall be connected to a collector main before discharging to a trunk sewer. In addition, if there is a history of Bad Sewer Odor (BSO) in the area, a gas trap, also known as a P-trap,

shall be installed on the laterals connected to the collector sewer main. The P-trap will be installed on private property. The decision to install the P-trap will be determined by the Senior Civil Engineer of the Wastewater Collection Division. A P-trap is a device that forms a barrier or seal to prevent sewer gas from rising up through a sewer main and lateral into a home or building (Ref. Figure 2-1).

- b. In special situations, as determined by Senior Civil Engineer of the Wastewater Collection Division, a sewer lateral may be allowed to connect directly to a manhole on the trunk sewer. In such cases, a P-trap shall be installed on the lateral at the required location mentioned above by the property owner, for new development.
- c. The property owner shall be responsible for the maintenance, repair and/or replacement of any P-traps.
- d. Direct discharge of a pressure lateral into a trunk sewer shall not be permitted. The pressure lateral may be designed to discharge into a gravity lateral prior to connection to the trunk sewer. The lateral must meet the criteria of Subsection 2.2.3.2 and the forced section of the lateral shall be designed per California Plumbing Code criteria for force mains.

2.5.10 **Common Laterals**

A separate sewer lateral shall be constructed from the sewer main to the property line of every lot within a new subdivision (Ref. Municipal Code § 144.0240).

- a. Common laterals for new construction will not be allowed.
- b. A separate lateral shall be provided for existing buildings which share a common lateral if the project includes a building expansion or reconstruction.

2.5.11 **Easement Laterals**

Sewer lateral connections in non-paved easements shall not be allowed where a connection can be made into a main in a public right of way or paved easement.

All laterals which connect to public sewer mains in easements rather than the public right-of-ways, whether in paved private streets or unpaved areas, shall be labeled as “Private” on the improvement plans.

2.5.12 **Main Extension Waiver**

Mains should be extended for new homes so that the laterals can be built perpendicular to the main. This requirement can be waived for an

encroachment lateral when all of the conditions are met for either the standard deviation or cul-de-sac category.

Single Family Residence

An encroachment sewer lateral that connects to a sewer main that is not in the lot frontage and not perpendicular to the main may be allowed for a single family residential unit when ALL of the following conditions are met:

Standard Deviation Category

- a. The lot does not front on a public sewer main.
- b. Ownership of the adjacent lot(s) does not belong to the subject lot owner.
- c. A service agreement between the City and the property owner is recorded against the subject lot (Encroachment Maintenance and Removal Agreement).
- d. The need for future extension of the main is not anticipated.
- e. The lateral does not exceed 300 feet in length.
- f. Where the installation or extension of a sewer main to connect to the existing City system is waived by the Senior Civil Engineer, contracts shall be executed for installation of future permanent facilities (Ref. Municipal Code §144.0231 (a), and §129.0715).

Cul-De-Sac Deviation Category (Dead End Streets)

- a. If in an existing dead-end street where an un-served lot can be served by a straight lateral that passes under the curb in their frontage (The lateral cannot pass under any portion of the neighbor's property curb).
- b. Each un-served lot can be served by a lateral that is 65 feet or less in length from the property line to the main.

Note: This lateral does not have to be perpendicular to the main and will be classified as public. Essentially this condition will be treated similar to a cul-de-sac.

Multi-Family Residential and Commercial Units

See Subsection 2.2.11.1

2.5.13 Encroachment Maintenance and Removal Agreement (EMRA)

All private laterals within the public right-of-way require an Encroachment, Maintenance and Removal Agreement (EMRA).

2.5.14 Laterals Crossing Lot Lines

- a. Sewer laterals shall not cross lot lines unless there are no other reasonable options. A private easement shall be dedicated to the lot benefiting from the lateral.
- b. All laterals crossing lot lines are encroachment laterals and shall be labeled as “Private” on the improvement plans.

2.5.15 Lateral Abandonment

In order to receive water and sewer capacity credits, the applicant shall obtain approval from the Development Services Center prior to demolition or abandonment of facilities (water meter, laterals or structures). Refer to Subsection 2.5.16.e below.

2.5.16 CIP Construction

The following actions shall take place for sewer laterals when a sewer main is being replaced or lined:

- a. Encroachment Laterals in the right-of-way are to be replaced as part of a CIP project using open cut excavation methods. The laterals shall be replaced from the main up to the edge of pavement (or concrete gutter).
- b. Shared laterals that serve single family residential lots shall be separated by providing each lot with a separate lateral per the Municipal Code. The new lateral to the adjoining lot shall be capped, documented and shall terminate just past the cleanout.
- c. Laterals that are in good condition shall be left in place except for the WYE connections at the main.
- d. Laterals that run approximately parallel to the street (not perpendicular to the main/curb) shall be left in place if they are in good condition. If they are not in good condition, they shall be replaced if a standard perpendicular lateral can be provided.
- e. Prior to demolition or abandonment of facilities (water meter, laterals or structures), a copy of the plans showing the lateral(s) to be abandoned with the corresponding addresses must be sent to Water and Sewer Development Review and the Development Services Center for review to ensure sewer capacity fee credits are properly recorded.

2.6 REHABILITATION

2.6.1 Pipeline Rehabilitation

Factors to consider for the classification of Rehabilitation:

- Pipe does not contain defects such as: collapsed pipe, medium to large displaced joints, medium to large deformations and sags.
- Roots at joints
- Evidence of infiltration
- Minimum slope for rehabilitation is 0.35%. This slope will produce a cleaning velocity of 2-feet per second in an 8-inch pipe, if there is adequate flow. Verification of all hydraulic information, slope, and location is needed before a final recommendation for rehabilitation
- Pipe location (ROW, canyons, easements)
- Adequate hydraulic capacity

Pipeline rehabilitation shall utilize, but is not limited to, slip-lining, pipe bursting, cured-in-place pipe (CIPP), point repair, cleaning, root removal and chemical treatment, internal chemical grouting, external grouting, and mechanical sealing.

The fabricated liner product shall comply with ASTM requirements and the City's Approved Materials List (AML).

Cleaning is required prior to CCTV inspection and rehabilitation to determine if the pipe is a candidate for rehabilitation. Sewer cleaning using a mobile high pressure sewer cleaning unit, power auger or reamer, or point repair must remove protruding lateral services, calcite buildups, roots, broken pipe sections, and all other debris.

Internal grouting and mechanical seals may be used to seal leaking sewer joints in structurally sound sewer pipes. A section of PVC pipe and/or rubber seal positioned across the defective joint shall be held in place by a stainless steel locking band (Mechanical seals similar to the Cretex™ seals).

Liners shall be placed continuous over the entire length between manholes.

Cleanouts will be installed per City of San Diego Drawing SC-01 when rehabilitating dead end mains.

2.6.2 Manhole Rehabilitation

Manholes with moderate to severe corrosion that could potentially affect the

structural integrity of the manhole over the next 50 years shall be classified for rehabilitation.

Manhole Rehabilitation shall include coatings, ladder rung removal, structural lining, sealing of frame-chimney joints, replacement of the precast chimney cone, installation of manhole bowls to collect inflow, replacement of the manhole base, and chemical grouting. Coating systems shall be used for the entire manhole, including the benching and invert unless these are in good condition.

2.6.3 **Lateral Rehabilitation**

Sewer lateral connections (SLC) to rehabilitated sewer lines shall be sealed, normally without excavation, by the installation of a resin-impregnated, flexible, felt tube or fiberglass tube installed into the existing service lateral. The tube shall form a “tee” section with a full lap inside the main pipe. The SLC may be a combination of “tees” or “wyes” of varying angle.

2.7 **WASTEWATER IMPROVEMENT PLANS—STANDARDS AND PROCEDURES**

2.7.1 **General**

Plans of all sewer facilities shall be routed through Water and Sewer Development Review, Public Utilities Department, for review and approval to ensure compliance and consistency and for coordination with development projects.

The planning functions for private developments (i.e. sewer studies, systems layout, and pipe sizing) are generally required of the Developer in the tentative map resolution. Any questions regarding these aspects should be directed to Water and Sewer Development Review.

Water and Sewer Development Review shall review the project for compliance with the tentative map requirements, design standards, and all applicable Regional Standard Drawings. Water and Sewer Development Review reviews the plans for special facilities, specifications (excluding general condition), and shop drawings.

In general, the City follows the American Water Works Association (AWWA) Standards and the *Standard Specifications for Public Works Construction* (Greenbook) including Regional and City of San Diego Supplement Amendments and ASCE publication 60.

2.7.2 **Improvement Plan Requirements**

All improvement plans shall be prepared in accordance with the City of San Diego Citywide Drafting/CADD Standards and this *Sewer Design Guide*.

2.7.2.1 Pipelines

Improvement plans for pipelines shall include the following minimum information:

- a. **Title Sheet(s)**: Location and vicinity maps; project title; legal description of the property; list of utility phone numbers; phone number for underground service alert; list of referenced improvement drawings; standard drawings; standard specifications; list of abbreviations; legend; work to be done; standard notes; engineer of work; statement of responsible charge; north arrow(s).
- b. **Plan and Profile Sheet(s)**: Scale; north arrow(s); screened profile grid; basis of bearings (if applicable); benchmark information; project title; existing and proposed contours over pipe; all existing or proposed utilities that may run parallel with or cross the new pipe (i.e. storm drain, potable water, pressurized irrigation, lighting and electrical, etc.); diameter of pipe; pipe material; concrete encasements; stream crossings, plan and profile of the proposed pipe(s).
 - 1). **Plan Strip**: Location of proposed pipe with horizontal ties to property and right-of-way boundaries or known and established physical improvements; all horizontal alignment information including stationing, horizontal curve data, location and description of structures.
 - 2). **Profile Strip**: Depth of cover; pipeline slopes; stationing; offsets (if applicable); bridge abutment locations and culvert crossings. For trunk sewers, include profile requirements per Subsection 2.2.7.
- c. **Details**: Special and complicated structures, if not included in the Regional Standard Drawings; complex utility crossings; special manhole(s); special trenches; sewer access road sections, etc.

2.7.2.2 Special Facilities

Improvement plans for special facilities such as pump stations and metering stations shall include the following information:

- a. **Title Sheet(s)**: Location and vicinity maps, project title, legal description of the property, list of utility phone numbers, phone number for underground service alert, list of referenced improvement drawings, standard drawings, standard specifications, list of abbreviations, legend; standard notes, engineer of work, north arrows on all maps and plan views.

- b. **Site Grading Plans:** Scale, north arrow, basis of bearings, benchmark information, existing and proposed contours, existing and proposed surface and subsurface drainage facilities, soils report (if required), finished elevations for proposed improvements. Legal descriptions shall accompany the plans.
- c. **Paving Plans:** Access, on-site vehicle parking, turnabout areas, proposed curbs, berms, gutters, walkways, wheel stops, and pavement striping, typical pavement sections.
- d. **Utility Plans:** Existing and proposed facilities for all on-site utilities (electricity, telephone, alarm, cable TV, water, sewer, storm drain, irrigation, gas, chilled water, steam, etc.)
- e. **Other Plans:** Irrigation and landscaping, structural, plumbing, mechanical, architectural, electrical, and instrumentation for special facilities.

2.7.2.3 **Standard Specifications and Drawings**

The following specifications shall be called out on all development plans:

- Standard Specifications for Public Works Construction (latest edition)
- Regional Supplement Amendments to Standard Specifications (latest edition)

The following standard drawings shall be called out on all development plans:

- San Diego Regional Standard Drawings (latest edition)
- City of San Diego Standard Drawings (latest edition)

Should any Caltrans easement, right-of-way, or structure be affected by the improvement plans, a note for the following plans shall be added:

- State of California Department of Transportation Standard Plans (latest edition)

2.7.3 **Notes on Improvement Plans**

The following notes shall be shown on the plans, as applicable:

1. Each lot shall receive a 4-inch sewer house connection, unless otherwise indicated on the plans or special specifications. Location shall be determined in the field by the engineer of work. The “As-Built” locations shall be shown on these plans and the sewer lateral table completed prior to acceptance of the sewer facilities.

2. Sewer house connections shall be located no less than 5 feet away from driveways. The sewer lateral and the water service line shall be separated at a horizontal distance of 5 feet and a vertical distance of 1 foot (with the water service at the higher elevation). The sewer lateral and the water service line shall be installed in a relative location so that the sewer lateral is located in the downstream direction of the street. If the above criteria cannot be met, the sewer lateral and the water service line shall be separated by 10 feet.
3. Providing sewer for this development is dependent upon prior construction of certain sewer facilities in previously approved development plans. If these facilities have not been constructed and accepted by the City at the time of connection, then certain portions of these previously approved or planned sewer facilities, as required by the City Engineer, will become off-site improvements as part of this development. Prior to connection to public sewer facilities, these off-site improvements shall be constructed and accepted by the City and documented as a construction change to this development. Model homes may be opened to the public when the Resident Engineer deems the sewer facilities substantially complete. No structure shall be occupied by the owner prior to signoff of all sewer-related punch list items and acceptance by the Public Utilities Department. Sewer facilities in such developments shall be dependent upon the completion and acceptance of the following approved off-site improvements of pre-existing sewer facilities:

(TITLE)

(DRAWING NUMBER)

4. All valves on sewer force mains shall be flanged to crosses and tees.
5. All buried ductile iron pipes, fittings, valves, and appurtenances shall have corrosion control measures as required by the City of San Diego's Sewer and Water Design Guides. If the corrosivity of the soil has not been determined by job-specific testing, all buried ductile iron pipe and fittings shall be installed with a bonded dielectric coating and cathodic protection. Bonded dielectric coatings shall be 24 mil DFT fusion bonded epoxy (AWWA C213/C116), liquid epoxy (AWWA C210), or polyurethane (AWWA C222). A cold, field applied, three-part petroleum wax tape coating system (AWWA C217) may be substituted for the bonded dielectric coating, if approved by the Resident Engineer.
6. **Shop Drawing Submittals:** Prior to fabrication, shop drawings shall be prepared and approved by the DESIGN ENGINEER. The DESIGN ENGINEER shall certify that the shop drawings meet the intent of the signed design plans and specifications. The approved shop drawings shall then be submitted to the Resident Engineer for a six (6) week review period. Once the shop drawings have been accepted by the Resident Engineer, fabrication of the materials may be started at the factory. Requests for plant inspections must be made a minimum of two (2) working days prior to fabrication if the factory is located in the Southern

California area. All plants located outside of Southern California must schedule inspection a minimum of seven (7) working days prior to fabrication. Refer to the latest edition of the *Standard Specifications for Public Works Construction, Section 4-1.3*, for inspection requirements.

7. All horizontal separation dimensions shown between potable water mains and all other wet utilities, such as sewer mains, storm drains, etc. shall be measured from the outside edge of each pipeline, per State of California Department of Public Health, Basic Separation Standards.
8. Private sewers shall be shown in both plan and profile for reference only to avoid conflicts and to show connections to public laterals or mains. All private sewers shown shall be installed under separate plumbing permit.
9. All proposed public sewer facility installations shall be constructed with materials listed in the most current edition of the City of San Diego Approved Materials List for Municipal Sewers. See the PUD Website at:

<http://www.sandiego.gov/mwwd/pdf/approvedmaterials.pdf>
10. In gated communities, the developer shall be responsible for providing the Wastewater Collection Division, Public Utilities Department, with keyed access.
11. No trees shall be allowed within 10 feet of any sewer main or lateral.
12. Prior to connecting to any existing sewer lateral, the lateral shall be inspected using a closed-circuit television (CCTV) by a California Licensed Plumbing Contractor to verify that it is in good working condition and free of debris.
13. All proposed sewers shown on the plans shall comply with the requirements of the current edition of the *Sewer Design Guide* of the City of San Diego.
14. **For all Sewer Plans:** The Contractor shall comply with all federal, state, and local laws, ordinances, codes, orders, and regulations which in any manner affect the conduct of the work, specifically as it relates to sewage spills. The Contractor shall be fully responsible for preventing and containing sewage spills, for recovery and legal disposal of any spilled sewage, and for any fines, penalties, claims and liabilities arising from causing a sewage spill and from violation of any law, ordinance, code, order, or regulation as a result of the spill(s).
15. **For Work Involving Live Sewer Facilities:** At least fifteen (15) days prior to the start of construction involving any existing wastewater facility, the Contractor shall be responsible for developing and submitting a Wastewater Flow Diversion Plan that will ensure “ZERO SPILLS”. The plan shall be submitted to the Resident Engineer for review and approval. The diversion plan shall include an emergency response plan indicating

the procedures, equipment, and activities that will be implemented in the event of an emergency shutdown or failure of the flow diversion equipment used for construction. The Contractor shall be responsible for implementation of the emergency plan in accordance with Section 805 of the 2009 City of San Diego Supplement Amendments (Doc. No. PITS 050409-2) to the *Standard Specifications for Public Works Construction*.

Additional notes may be required by the Plan Reviewer to address specific project requirements.

2.7.4 **Legend Items**

The following legend items and corresponding standard drawings shall be shown on the plans, as applicable:

- a. Size (INCHES), Type (MATERIAL), and Rating (CLASS) of Sewer Main: SDS-100, SDS-101, SDS-110(C), and SDS-100.
- b. Sewer Manhole (No Steps): SDS-100, SDS-107 (for 15-inch diameter mains and smaller, PVC-lined), SDS-106 (for 18-inch diameter and larger mains, PVC-lined), (use SDM-113 locking cover in all unpaved areas for SDS-106 and SDS-107 manholes), all manholes shall be PVC-lined when invert elevation is below +7 feet mean sea elevation, below a water table, or when installed at the point where force main flows convert to gravity flow.
- c. Sewer Lateral (4" PVC) with Cleanout: SDS-100, SDS-105, SDS-108, SDS-110(C), SDS-102, and SDS-103.
- d. Concrete Encasement: SDS-100, SDS-112 (ESVC, Lined and Coated Ductile Iron or Sleeved Steel Pipe) The Contractor shall submit shop drawings for approval. In addition, the use of ductile iron requires a full review and approval by the Corrosion Control Section of the Public Utilities Department.
- e. Cut-off Wall (Type A): SDS-100, and SDS-115.
- f. Sewer Main Anchor: SDS-100, and SDS-114.
- g. Sewer Lateral Cleanout: SDS-100, SDS-102, and SDS-103. No cleanouts at the property line are required for encroachment laterals.
- h. Sewer Cleanout (Force Main): SDS-100, and SDS-109.
- i. Schedule "J" Paving: SDG-113 NOTE: These designs shall be used in the public right-of-way or on private property in those areas where public easements are granted, including sewer access easements.

2.7.5 Data Tables

Tables 2-8, 2-9, and 2-10 shall be shown on the plans and completed, as applicable:

2.7.5.1 Sewer Main Abandonment

**TABLE 2-8
SEWER MAIN ABANDONMENT**

SYMBOL	SIZE (inches)	TYPE	LENGTH (feet)	YEAR INSTALLED

2.7.5.2 Sewer Data Table

**TABLE 2-9
SEWER DATA TABLE**

NO.	BEARING/DELTA	RADIUS	LENGTH	NOTES

NOTE: Allowable Minimum Radius of Curvatures (Longitudinal Bending for Flexible Pipe, PVC) is 8" = 200', 10" = 250', 12" = 300', and 15" = 350'.

2.7.5.3 Sewer Lateral Table

**TABLE 2-10
SEWER LATERAL TABLE**

Lot #	I.E. at Main	Drop to Main (Rise)	Length in Feet	I.E. @ P.L.	Slope (%)	Top Curb Elev. (T.C.)	Depth Below T.C. @ P.L.	Sta #	Survey Location of Cleanout	Remarks
		Note 1			Note 2					

NOTES:

1. Show Drop to Main for all laterals; 1.2' for 8" mains, 1.3' for 10", 1.4' for 12", 1.8' for 15".
2. Minimum slope is 2% for all laterals.

LEGEND: I. E. = Invert Elevation; P. L. = Property Line; T. C. = Top of Curb

2.8 **PLANNING AND DESIGN SUBMITTAL REQUIREMENTS**

2.8.1 **General**

This section represents the minimum requirements for the submittal of public improvement or grading plans for review. Prior to submitting public improvement or grading plans, it is the responsibility of the DESIGN ENGINEER to verify that all Tentative Map conditions have been incorporated into the plans along with all other necessary requirements. Failure to meet these minimum requirements could result in plans being returned without review.

2.8.2 **Sewer Study**

When a sewer study is required, the sewer study shall be approved and plans shall be in conformance with the approved sewer study **prior to submittal of public improvement or grading plans** for review. To ensure the timely processing of plans, provide a copy of the sewer study approval letter or approval email with the initial plan submittal.

2.8.3 **Public Easements**

Public sewer/general utility easement drawings, when required, shall be submitted concurrently with all public improvement or grading plans.

2.8.4 **Encroachment Maintenance and Removal Agreement (EMRA)**

Encroachment Maintenance and Removal Agreements, when required, shall be submitted and reviewed concurrently with all public improvement or grading plans.

2.8.5 **Covenants, Conditions, and Restrictions (CC&R)**

Covenants, Conditions, and Restrictions, when required, shall be submitted and reviewed concurrently with all public improvement or grading plans.

2.8.6 **Minimum Plan Sets**

A minimum of two (2) sets of public improvement or grading plans will be required for all submittals for wastewater review. When a special facilities plan check is required, additional sets shall be required. (Refer to Section 2.9 for requirements).

2.8.7 Sewer Maintenance Plan

For sewers which will be located in canyons and/or in environmentally sensitive areas, a copy of the approved, sewer maintenance plan shall be submitted with the first submittal of the improvement plans.

2.9 CONSTRUCTION PLAN MINIMUM INTAKE CHECKLIST - QUALITY ASSURANCE/QUALITY CONTROL

Included in the Checklist (ATTACHMENT 5) are some of the common plan check comments made during the review cycle of wastewater improvement plans. These comments should be used during the performance of in-house QA/QC plan review by the DESIGN ENGINEER of wastewater improvement plans prior to submittal to Water and Sewer Development Review for plan review.

ATTACHMENT 5 must be completed, signed and included with each set of construction plans submitted for review by Water and Sewer Development Review. Failure to complete or include the check list will result in the return of the design documents without review or approval.

The DESIGN ENGINEER shall indicate compliance with or deviation from each of the items by placing a check mark in the appropriate column and initialing the item. All deviations must be addressed in the comments section at the end of the form. Attach additional information where requested.

The completed form shall be signed and dated in the indicated locations by the Engineer of Record.

2.10 SPECIAL FACILITIES PLAN CHECK

Improvement plans for special facilities such as large trunk sewers (18 inches and larger), sewer pump stations, force mains, metering stations, and other non-standard facilities shall be routed to the Public Utility Department's Wastewater Collection Division for review and comments prior to final approval of the plans by Water and Sewer Development Review. This process shall also be applicable for review of encroachments affecting special facilities. Water and Sewer Development Review will ensure that all operating divisions' comments are appropriately addressed and that the plans and specifications conform to consistent standards prior to final approval.

Improvement plans for sewer pump stations will not be signed off by Water and Sewer Development Review until written approval by memorandum or signature on the plans has been obtained from the Senior Civil Engineer of the Wastewater Collection Division of the Public Utilities Department (PUD).

Water and Sewer Development Review will require seven (7) sets of plans, seven (7) sets of specifications, and three (3) sets of design calculations for special facilities. Three (3) sets of plans and specifications and two (2) sets of calculations will be sent to the operating division for the operational, maintenance, telemetry, and electrical review and comments. Two (2) sets of plans, plus calculations, and specifications are for Water and Sewer Development Review for design and policy reviews. Two (2) sets of plans and specifications are for the Corrosion Engineer's review and comments. Water and Sewer Development Review's comments, as well as the comments from other reviewers, will be returned to the project engineer. Water and Sewer Development Review will keep one (1) set of plans, specifications, and calculations with a composite of the comments and corrections from all other divisions.

When specifications can be placed on five (5) sheets of plans or less, they shall be placed on the plans. When specifications exceed five (5) sheets of plans, facility plans shall have a blank space designated for the document number assigned to the specifications.

The DESIGN ENGINEER shall ensure that all shop drawings to be "As-Built" for special facilities are placed on standard City "D" size mylar sheets and added to the plans. A block of D-Sheet numbers can be provided by Engineering Maps and Records Section of Land Development Review Division, via City project managers or engineers. However, it is important to have a single person to look after the block of D-Sheets and to maintain frequent communications with Engineering Maps and Records Section with the view of providing them with current information to enable them to register the D-Sheet numbers as and when they are assigned to project drawings.

Facility plans shall have a designated space for recording the document number assigned to the specifications.

G:\programing\TQ Tran\Stephanie\CAD Details\Sewer Design Guide\Gas Trap.dgn
 TQT
 4/19/2012

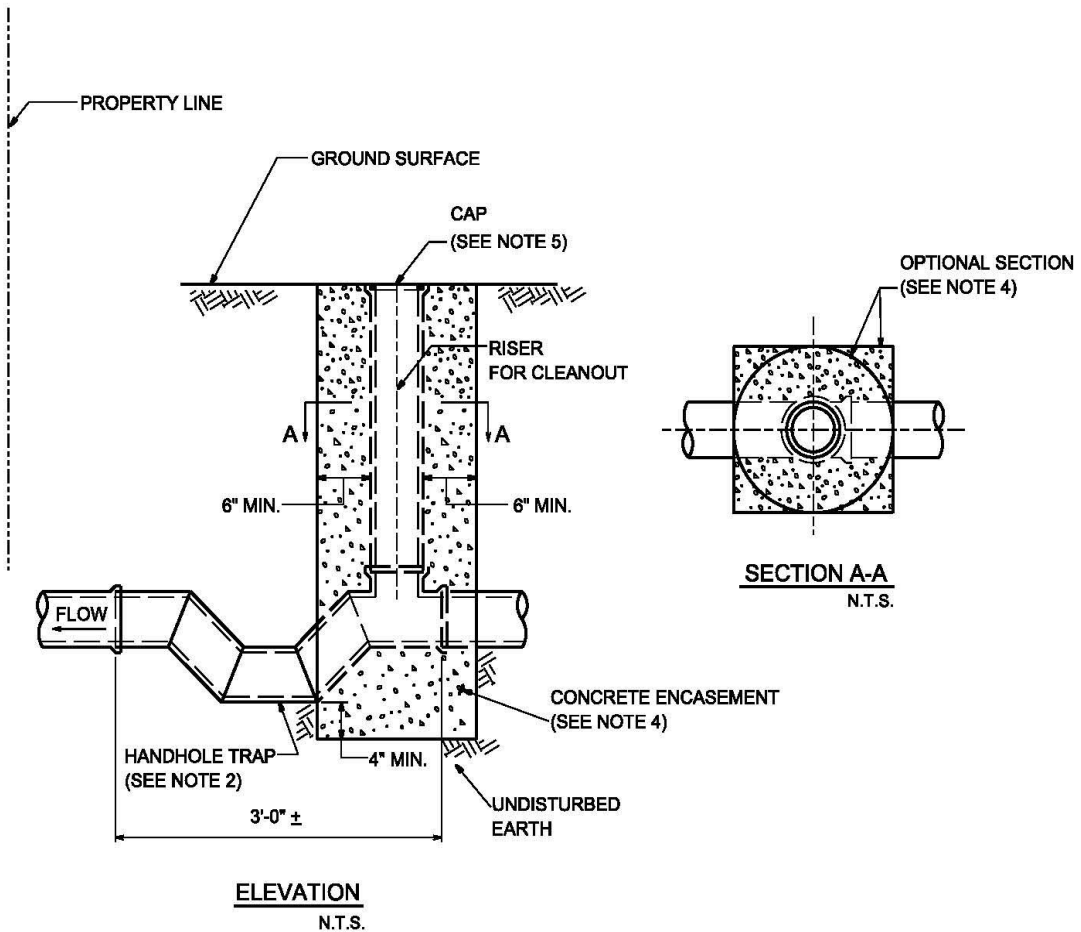

NOTES:

1. EXCEPT AS OTHERWISE INDICATED HEREON OR ON THE PROJECT PLANS, CONSTRUCTION SHALL CONFORM TO THE APPLICABLE PORTIONS OF STANDARD PLAN, HOUSE CONNECTION SEWERS AND HOUSE CONNECTION REMODELING.
2. THE HANDHOLE TRAP MAY BE FABRICATED OF MITERED SECTION AS SHOWN HEREON, OR OF A SINGLE UNIT WITH CURVED SEGMENTS.
3. PLAIN END PIPE MAY BE USED IN LIEU OF BELL (SOCKET) AND SPIGOT FITTED PIPE PROVIDED APPROVED COUPLINGS ARE USED.
4. THE CONCRETE ENCASEMENT AROUND THE RISER ABOVE THE TOP OF THE HOUSE CONNECTION TEE MAY BE CIRCULAR OR RECTANGULAR IN CROSS SECTION. FROM THE BOTTOM OF THE ENCASEMENT TO THE TOP OF THE HOUSE CONNECTION TEE, THE ENCASEMENT SHALL BE RECTANGULAR IN CROSS SECTION. ENCASEMENT SHALL BE CLASS 420-C-2000 CONCRETE.
5. THE RISER SHALL BE SEALED WITH A CAP AND 1 INCH THICK TYPE "F" MORTAR AROUND THE CIRCUMFERENCE OF THE CAP.
6. THE HANDHOLE TRAP SHALL BE BEDDED IN THE SAME MANNER AS THE HOUSE CONNECTION SEWER.

GAS TRAP

FIGURE 2-1

G:\PROJ\HAND\TO TRANS\STEPHANIE\CAD DETAILS\SEWER DESIGN GUIDE\JKW05C4.DWG
 8/10/2011
 TOT

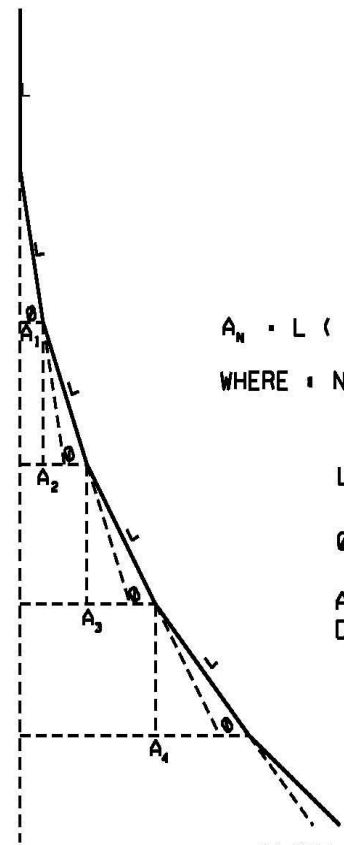

$$A_N = L (\sin \theta + \sin 2 \theta + \dots + \sin N \theta)$$

WHERE : N = 1, 2, 3 N

L = PIPE LENGTH IN FEET

θ = JOINT DEFLECTION IN DEGREES

ALSO REFER TO PIPE MANUFACTURER'S DATA & RECOMMENDATIONS

JOINT DEFLECTION

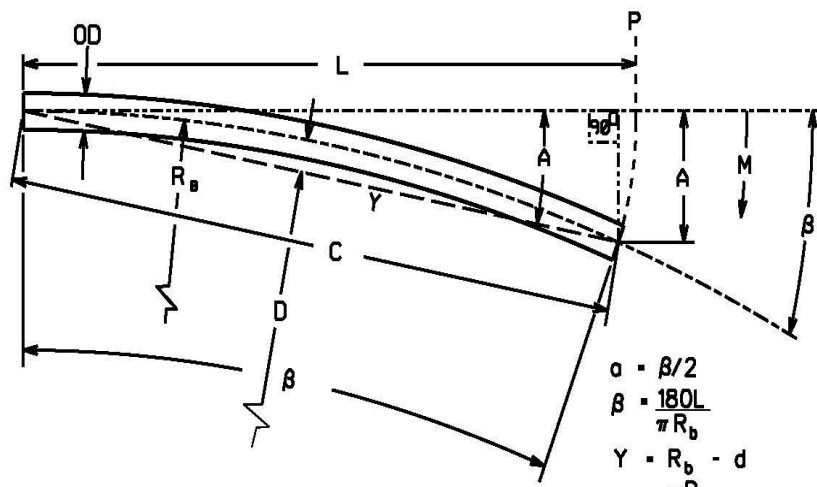

$$\alpha = \beta / 2$$

$$\beta = \frac{180L}{\pi R_b}$$

$$Y = R_b - d$$

$$L = \frac{\pi R_b \alpha}{90}$$

$$d = R_b \cos \beta / 2$$

$$C = 2R_b \sin \beta / 2 \approx L$$

$$A = 2R_b (\sin^2 \beta / 2) = C \sin \beta / 2$$

BENDING

JOINT DEFLECTION ALLOWANCES

FIGURE 2-2

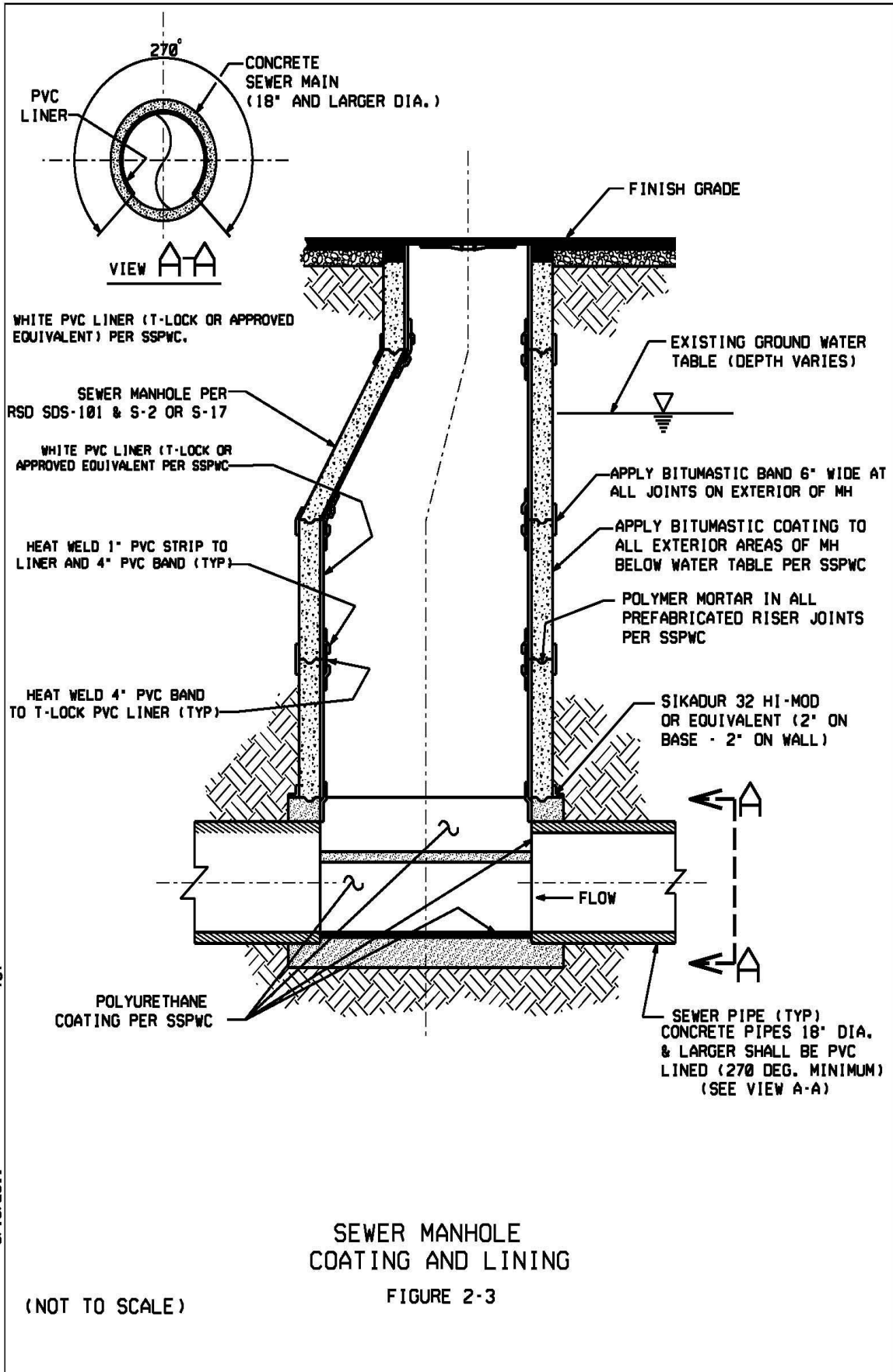

G:\PROGRAMS\TO TRANS\STEPHANIE\CAD DETAILS\SEWER DESIGN GUIDE\JKYDGS4.DWG
TOT
8/10/2011

PIPES SAME DIAMETER STRAIGHT THROUGH FLOW

1. ALIGN PIPE CENTERLINES AT IDENTICAL SLOPES.
2. CHANNEL MANHOLE BASE SMOOTHLY FROM PIPE I.D. TO PIPE I.D.,
ALLOWING FOR THICKNESS OF POLYURETHANE COATING OF CHANNEL.

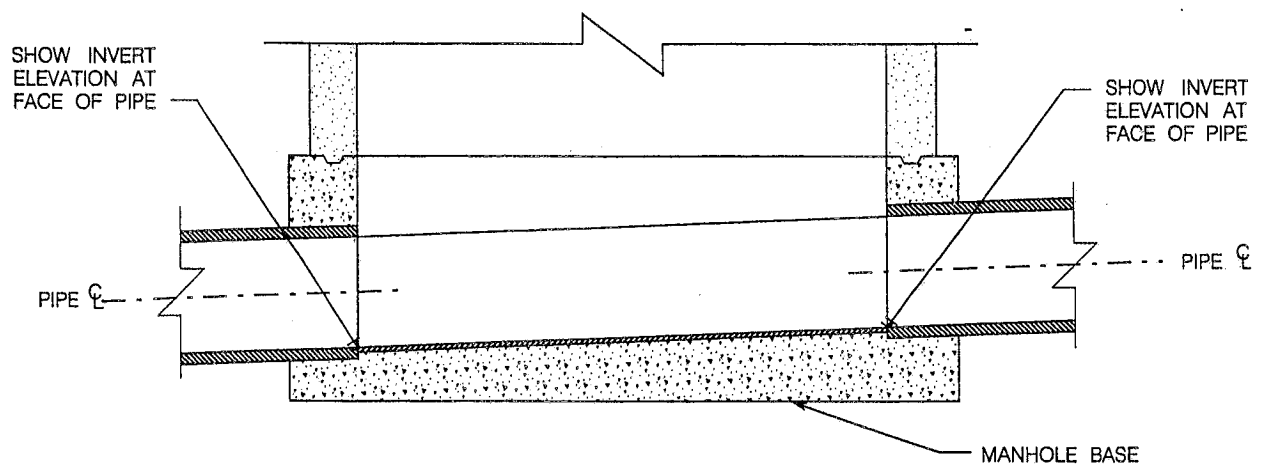

PIPE LOCATIONS FOR STRAIGHT THROUGH FLOW

FIGURE 2-4

OUTLET PIPE LARGER THAN INLET STRAIGHT THROUGH FLOW

1. ALIGN PIPE CENTERLINES AT IDENTICAL SLOPES.
2. CHANNEL MANHOLE BASE SMOOTHLY FROM PIPE I.D. TO PIPE I.D.,
ALLOWING FOR THICKNESS OF POLYURETHANE COATING OF CHANNEL.

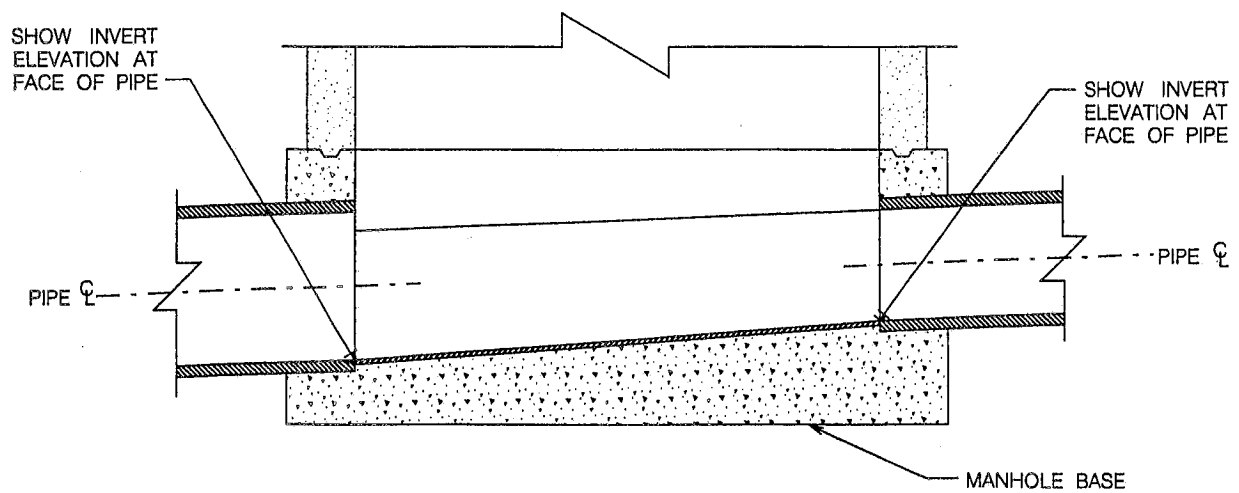

PIPE LOCATIONS FOR STRAIGHT THROUGH FLOW

FIGURE 2-5

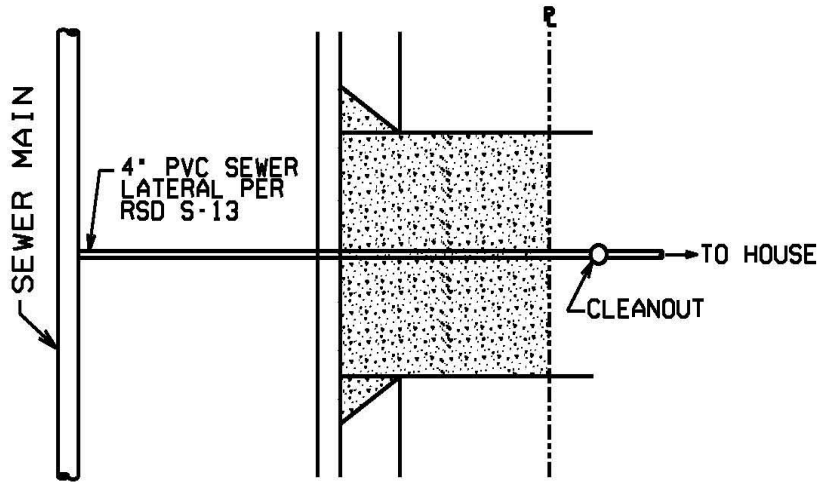

PLAN VIEW
(NO SCALE)

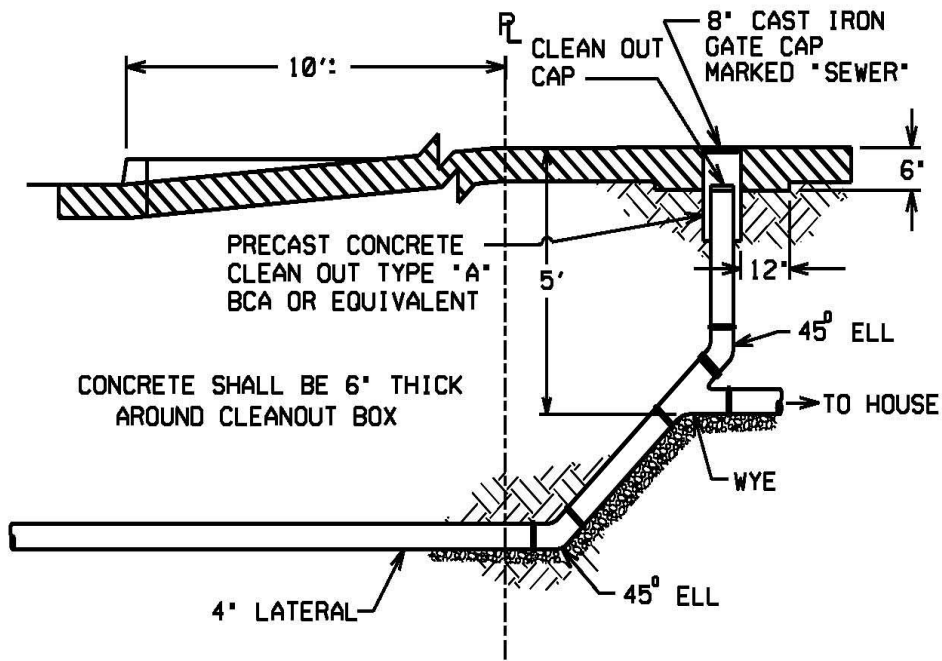

PROFILE
(NO SCALE)

PRIVATE SEWER LATERAL IN CONCRETE CEMENT DRIVEWAY

FIGURE 2-6

G:\PROGRAMS\TO_TRAN\STEPHANIE\CAD DETAILS\SEWER DESIGN GUIDE\JKW05C4.DGN
8/10/2011 101

CHAPTER 3 EASEMENTS AND ENCROACHMENTS**3.1 GENERAL**

This chapter addresses the different types of easements and encroachments for sewer systems.

The City shall have permanent easements for all sewer facilities that are outside of the public right-of-way or outside of lots owned in fee title by the City of San Diego.

All plans for new easements within the limits of a proposed project and proposed encroachments into new or existing City easements or facilities shall be routed through Water and Sewer Development Review, Public Utilities Department.

Any existing substandard easements, within the limits of a proposed project, shall be upgraded to current standards prior to the approval of any improvement permit by Water and Sewer Development Review, Public Utilities Department.

In determining the proper easement width for a wastewater facility, there are two independent criteria which must be considered. The first criterion is based on the ability of construction equipment to access the main and laterals for emergency maintenance or replacement. The second criterion is based on vehicular access to manholes and appurtenances where a continuous road along the sewer alignment is not available. These criteria incorporate constructability concerns, access, maintenance issues, and other special design requirements.

The DESIGN ENGINEER shall determine the required easement width, based on an independent analysis of each of these sets of criteria, and shall utilize the larger of the two required easement widths, which shall govern.

3.2 EASEMENT REQUIREMENTS**3.2.1 Location of Easements****3.2.1.1 Preferred Location**

Where the DESIGN ENGINEER has the choice of locating the sewer main in a street or in an easement, the sewer main shall be located in the street. The DESIGN ENGINEER must satisfactorily demonstrate that no other reasonable alternative alignment exists prior to requesting permission to locate a sewer, trunk sewer, or sewer force main within an easement.

3.2.1.2 **Easements within Lots**

Easements shall be located entirely within one lot or parcel and longitudinally adjacent to the property line. Bisecting a lot with an easement shall not be permitted. Existing sewers within easements which cut across an undeveloped lot shall be considered temporary and shall be relocated to streets or adjacent to the property line, as a condition of development or as part of any sewer replacement project.

3.2.1.3 **Non-Contiguous Sewer Easement Roads**

Wherever possible, the sewer easement and access road shall be co-located. Where access along the sewer easement is interrupted by slopes, curbs, landscaping, etc., a separate access easement and road shall be provided to each manhole, isolated section of main, or other appurtenant structure. Where the sewer is located in an easement which is not for the exclusive use of sewer maintenance vehicles, the easement and access road shall be designed per the requirements of Subsection 3.2.3.1.

3.2.1.4 **Fenced Easements**

Easements secured by fencing shall have a locked vehicular access gate. Keys to the lock shall be provided to the various utility agencies with facilities enclosed by the fenced area.

3.2.2 **Easement Width**

The DESIGN ENGINEER shall determine the required easement width based on the criteria described below, and as summarized in Table 3-1. As indicated in Table 3-1, the required easement width shall be cumulative, based on a summation of all the design factors A through I. In all cases, the easement width shall be adequate to ensure that excavation of the sewer mains can be accomplished in compliance with all OSHA (Occupational Safety and Health Administration) and Cal-OSHA requirements with the use of standard shoring techniques. Construction details may be required by the Senior Civil Engineer to verify that the easement width is adequate. Special shoring and bracing techniques are not an acceptable alternative to providing adequate easement width since these methods cannot always be utilized in emergency situations.

3.2.2.1 **Minimum Width - Sewer Depths Less than 10 Feet**

Minimum widths for sewer easements shall be as follows:

Sewer mains 15 inches in diameter and less shall require a minimum 15-foot wide easement. A minimum 20-foot wide easement shall be required for 18-inch to 33-inch diameter mains and a minimum 25-foot wide easement shall be required for mains 36 inches in diameter and larger. Additional easement width, beyond the prescribed minimum 25 feet, may be required for sewer mains 36 inches in diameter and larger. (Ref. Table 3-1, "A" Width).

3.2.2.2 Sewer Depths Greater Than 10 Feet

Wider easements shall be required when the sewer pipe is placed at depths greater than ten feet, measured from finished grade to the invert elevation. In such cases, the easement or road width shall be increased beyond the minimum “A” widths required for the sewer in this chapter by a minimum of 2 feet for each additional foot of depth beyond 10 feet in order to permit a one-to-one slope on each side of the trench. Allowable distances between adjacent utilities should be adjusted accordingly so that the sewer may be repaired without disruption to adjacent utilities. Required widths for a reach of pipe shall be uniform from manhole to manhole and shall be based on the deepest section for that reach of pipe. Deep sewers (greater than 15 feet) require special approval (Ref. Subsection 2.2.1.5), they may also require additional easement width (Ref. Table 3-1, “B” Width).

3.2.2.3 Structures Adjacent to Easement

A minimum of five feet of additional easement width shall be required for sewer mains which are located in areas difficult to access, such as adjacent to a building. Easements with the potential for structures on one side of the easement require 5 feet of additional width. If structures could be constructed on both sides of the easement, provide 10 feet of additional width (Ref. Table 3-1, “C Width”). This requirement may be waived if the property adjacent to the sewer easement has a level building-setback area which is at least five feet in width exclusive of the easement.

3.2.2.4 Multiple-Use Easements

Easements located in private streets that contain more than one utility line shall require a minimum of 10 feet of additional width for each additional utility (Ref. Table 3-1, “D” Width and Subsection 3.2.4.2). Deviations from this requirement may be allowed on a case-by-case basis.

3.2.2.5 Easements in Open Space Areas

Easements in open space shall require a minimum of 5 feet additional width (Ref. Table 3-1, “E” Width).

3.2.2.6 Easements in Dedicated Parklands

City Charter, Section 55 allows for the installation of underground facilities within dedicated parklands provided the surface of the land is restored to its original condition and the facility does not detract from the use of the land for park and recreational purposes. Sewers through dedicated parklands shall be centered over a sewer maintenance corridor which shall be designated on the plans and shall be in agreement to the width and requirements for easement

mains. Sewer access roads to appurtenances shall also be shown as “Designated Sewer Access Road”. The easement shall require a minimum of 5-foot of additional width (Ref. Table 3-1, “F” Width).

3.2.2.7 **Easements in Commercial/Business Property and/or Private Streets**

Easements located in commercial/business property, and/or private streets, private driveways of industrial complexes, apartment complexes, subdivisions with private streets, and condominium complexes, that are required for vehicular access for sewer maintenance, shall be 20 feet wide minimum and paved the full width of the easement. Additional easement widths are required (Ref. Table 3-1, “G” Width). The minimum width of a street is 28 feet per the “Street Design Manual”. Where additional easement width is required, the entire easement shall be paved. Public sewers are not permitted within single lots unless they serve off-site customers. If excavation for the main would eliminate vehicular or pedestrian access to the parking lot, a fire lane, or the entrance to the building or access to homes or businesses, additional easement shall be provided as determined by the Senior Civil Engineer. If emergency access is governing the width of the easement, the engineer may consider providing redundant access.

3.2.2.8 **Easements Adjacent to Slopes, Buildings, or Retaining Walls**

Any sewer easements adjacent to slopes, buildings, or retaining walls shall require special design and calculations by a Registered Civil Engineer to show that there will be no adverse loading on the sewer and that the limits of the trenching operations for sewer repair or replacement will be outside the area of influence of the slopes, buildings, or retaining walls (Ref. Table 3-1, “H” Width). Additional easement shall be provided as determined by the Senior Civil Engineer.

3.2.2.9 **Easements in Areas with Special Soil or Geotechnical Concerns**

Standard easement widths are based on stable soils that can safely stand vertical with standard shoring techniques. In areas where soil conditions dictate, additional easement width may be required in order to assure adequate width for open-cut replacement of the sewer mains. The DESIGN ENGINEER shall provide construction details, as required by the Senior Civil Engineer, to verify that excavation of the sewer mains can be accomplished in compliance with all OSHA and Cal-OSHA requirements using standard shoring techniques. Special shoring and bracing techniques are not an acceptable alternative to providing adequate easement width since these methods cannot always be utilized in emergency situations (Ref. Table 3-1, “I” Width).

3.2.2.10 Easement Width Rounding

In calculating the required easement width, the DESIGN ENGINEER shall round up the calculated easement width to the nearest 5 feet.

**TABLE 3-1
WORKSHEET FOR CALCULATING REQUIRED SEWER EASEMENT WIDTHS**

Refer to Section	Width Addition Reference	<u>Condition:</u> and Width Addition Calculation:	Comments:	Easement Width
3.2.2.1	“A” Width	<p><u>If Sewer Depths of 10’ or less:</u></p> <p>Diameter < 18”: “A” Width = 15’</p> <p>Diameter of 18” to 33”: “A” Width = 20’</p> <p>Diameter > 33”: “A” Width = 25’</p>	Larger sewer mains may require additional “A” easement width as determined by the Senior Civil Engineer and special approval.	“A” Width =
3.2.2.2	“B” Width	<p><u>If Sewer Depths exceed 10’:</u></p> <p>For all pipe sizes, add to the minimum as follows:</p> <p>“B” Width = (Total Depth - 10’) x 2</p>	Deep sewers (greater than 20 feet) require special approval by the Senior Civil Engineer and shall require additional easement width.	“B” Width =
3.2.2.3	“C” Width	<p><u>If there are existing or potential structures on either side of the proposed sewer easement:</u></p> <p>For all pipe sizes, add to the minimum as follows:</p> <p>“C” Width = (No. of sides with adjacent structures) x 5’</p>	Easements with the potential for structures on one side of the easement require 5 feet of additional width. If structures could be constructed on both sides of the easement, provide 10 feet of additional width.	“C” Width =
3.2.2.4	“D” Width	<p><u>If there are additional utilities in the easement:</u></p> <p>For all pipe sizes, add to the minimum as follows:</p> <p>“D” Width = (No. of additional utilities) x 10’</p>	Any additional utilities must also comply with the minimum separation requirements.	“D” Width =

3.2.2.5	“E” Width	<p><u>If the sewer is located in Open Space</u></p> <p>For all pipe sizes, add to the minimum as follows:</p> <p>“E” Width = 5’</p>	<p>The width of the paved section within the easement to be determined in section Subsection 3.2.6</p>	“E” Width =
3.2.2.6	“F” Width	<p><u>If the sewer is located in Dedicated Parkland:</u></p> <p>For all pipe sizes, add to the minimum as follows:</p> <p>“F” Width = 5’</p>		“F” Width =
3.2.2.7	“G” Width	<p><u>If the sewer is located in Commercial/Business Property or Private Streets:</u></p> <p>The minimum width shall be 20’ and 28’ where the road serves more than one lot.</p> <p>For all pipe sizes, add to the minimum as follows:</p> <p>“G” Width = Based on Consultation</p>	<p>If excavation for the main would eliminate vehicular or pedestrian access to the parking lot or entrance to the building or precludes emergency vehicles, additional easement shall be provided as determined based on a consultation with the Senior Civil Engineer.</p>	“G” Width =
3.2.2.8	“H” Width	<p><u>If the easement is adjacent to slopes, retaining walls or other special site or building construction:</u></p> <p>For all pipe sizes, add to the minimum as follows:</p> <p>“H” Width = Based on Consultation</p>	<p>Special design and calculation by a Registered Civil Engineer to show sufficient easement width and pipeline placement for required construction and/or repair operations. Consult with the Senior Civil Engineer.</p>	“H” Width =
3.2.2.9	“I” Width	<p><u>If the easement is in an area with special soil or other geotechnical concerns:</u></p> <p>For all pipe sizes, add to the minimum as follows:</p> <p>“I” Width = Based on Consultation</p>	<p>Special design and calculation by a Registered Civil Engineer to show sufficient easement width and pipeline placement for required construction and/or repair operations. Consult with the Senior Civil Engineer. Sewer access areas shall be located in stable geotechnical</p>	“I” Width =

			soils, and the DESIGN ENGINEER shall provide a soils report for pipelines transitioning cut/fill areas.	
	Total above Widths = (A+B+C+D+E+F+G+H+I)			Total above Widths =
	Total Minimum Easement Width is “rounded up” to the next 5-foot value			Total Minimum Easement Width =

3.2.3 Access Facility Requirements

The intent of landscaping design for access facilities is to preclude landscaping that will impact the sewer, provide clear access for cleaning and maintenance equipment without pruning, and promote rapid recovery of damaged shrubbery within the construction/repair area.

3.2.3.1 Standard Sewer Access Roads

Access roads must be provided to all sewer main appurtenances (manholes, junction structures, etc.). Access roads shall be a minimum of 20 feet wide, with a maximum 15 percent slope, and shall have a minimum asphalt concrete or Portland cement concrete road section designed for H-20 loading and per City of San Diego Drawing SDG-113, Schedule “J”. Where access roads are not for the exclusive use of sewer maintenance vehicles, the road shall be designed to maintain pedestrian and/or vehicular access (as applicable) during sewer main repair and maintenance operations and shall be a minimum of 24 feet in width. The minimum turning radius for access roads shall be 30 feet for right angle turns and 50 feet for turnarounds per City of San Diego Drawing FHPS-101. All dead-end access roads longer than 150 feet shall have a turnaround consistent with City of San Diego Drawing FHPS-101.

3.2.3.2 Access Roads in Residential Side Yards

A sewer access road to a manhole, which is located in a residential side yard, may be reduced to 12 feet in width provided the sewer is upgraded to full encasement, from manhole to manhole. This provision is only applicable in cases where there are no existing or potential lateral connections to the side yard sewer. This provision does not provide for a reduction in the required sewer easement width as defined in Table 3-1.

3.2.3.3 Access Roads in Dedicated Parks

Sidewalks and driveways within access roads shall be upgraded to H-20 loading. Special reinforcing is required at expansion joints to prevent failure at the corners. Sewer facilities and access roads must be approved by the Park and Recreation Department.

3.2.3.4 Access Facilities in Environmentally Sensitive Lands

a. General

Native species shall be selected that are typical of the adjacent land and that can be cut at ground level and recover if they are damaged during main reconstruction. Shrub plantings shall be hand located by the landscape architect in the field, and shall be placed so the shrub does not extend over the access facilities at plant maturity in accordance with Exhibits 3-1 and 3-2.

Plant materials on the access facility surface must be consistent with the approved planting palette included in ATTACHMENT 4. No threatened or endangered plant species shall be planted or seeded on sewer access facilities or within 10 feet of sewer mains.

b. Sewer Access Roads – New Sewers in Environmentally Sensitive Lands

This section is specific for new sewers per Exhibit 3-1 “Sewer Access Roads in Environmentally Sensitive Lands”. This can be designated or dedicated property managed by the City. For City-owned open space, access road requirements shall be approved by the managing department. (See Subsection 3.2.3.3)

Access roads in open space shall be graded level for 20 feet in width. The roadbed section shall be centered over the sewer main where possible. The improved roadbed shall be a minimum of 12 feet wide and shall be designed for H-20 loading and per City of San Diego Drawing SDG-113, Schedule “J”, or equivalent. The roadbed shall be topped with an engineered geotextile filter fabric with a minimum 4 inch decomposed granite surfacing and soil bonding agent. In open space areas, roadways with slopes of 9 to 15 percent shall be topped with colored concrete to match the natural soil color. The surface shall be treated to mimic a natural trail and the first 12 inches past the edge of pavement will incorporate soil stabilizing if slopes exceed 4%. No asphalt products shall be used in open space easements. In open space areas, an equivalent section of recycled, Class II base, free of oil-based products, may be used in lieu of Cement Treated Base (CTB).

Consideration should be given to environmental impacts of required access roads so that the impacts of the roads can be addressed in the environmental document during the early stages of a project. Access roads should be located

in geotechnically stable areas, away from environmentally sensitive areas, and a minimum of two feet above the 100-year flood plain, based on the ultimate development of the drainage basin.

c. Sewer Access Paths – Existing Sewers in Environmentally Sensitive Lands

This section is specific for existing sewers per Exhibit 3-2 “Sewer Access Paths in Environmentally Sensitive Lands”. The construction shall be in accordance with the following for the purpose of main repair and pipe stoppage elimination with canyon proficient vehicular equipment:

A bench for the path shall be limited to the width of the path and when pipelines are constructed utilizing bench grading. The bench can be left in place with appropriate grading to resemble undulating natural contours.

Erosion control measures shall be provided. The grading for sewer access paths shall meet the criteria for canyon proficient vehicles with a maximum allowable slope of 25% and a maximum allowable cross slope of 12%.

The maximum length of a dead end access path shall be 15 feet and the minimum allowable turning radius shall be 35 feet.

Where access paths cross a stream, ditch, or other depression that cannot be negotiated by canyon proficient maintenance equipment, the DESIGNER shall consider the feasibility of the following options including, but not limited to: alternative access, temporary bridge, bridge, culvert, interlocking pavers, Arizona style crossing, fiord, temporary measures, or Grasscrete waterway. The DESIGNER shall recommend a preferred crossing and shall provide justification for the choice.

Where an access path surface is subject to becoming undetectable over time, the DESIGNER shall propose a demarcation mechanism, other than use of a global positioning system, by which maintenance crews can find and follow the path in the future.

3.2.4 Location of Utilities within an Easement

3.2.4.1 General

The sewer main shall be centered in the easement. Other factors, such as additional utilities in the easement, or adjacent slopes may dictate that the sewer main not be placed in the center of the easement. The minimum distance from the edge of the pavement and edge of the easement to edge of sewer main shall be 10 feet. Paving width may be reduced in areas where there is no public access.

3.2.4.2 **Additional Utilities**

Wider easements shall be required where additional utilities are located in the same easement (refer to Table 3-1”D” Width). The sewer shall be located a minimum of 10 feet from the edge of pavement and 10 feet, edge to edge, from all other utilities. Deviations may be permitted on a case-by-case basis in accordance with Subsection 2.2.5. In cases where the easement contains water and sewer mains, the water main shall be located 6 feet to the south or east of the centerline, and the sewer main 6 feet to the north or west of the centerline. If the invert elevations of a storm drain located adjacent to a sewer differ by more than 5 feet, additional easement width will be required. Distances shall be measured between all utilities from edge to edge. Where additional easement width is required, the entire easement shall be paved.

3.2.4.3 **Sewer Laterals in a Private Street Easement**

Laterals are not permitted in private street easement mains unless the easement is a minimum 28 feet wide and paved full width (refer to Subsection 2.2.5).

3.2.4.4 **Private Easements**

Separate easements shall be required for utilities owned by agencies or companies other than the City of San Diego.

3.3 **ENCROACHMENTS**

3.3.1 **General**

Encroachments into sewer easements shall be consistent with City Council Policy 700-18. Construction of permanent structures shall not be allowed over a sewer main or in sewer easements.

3.3.2 **Structures in Easements**

In cases where the DESIGN ENGINEER wishes to locate a permanent structure in an existing easement, the existing main and easement shall be relocated to a location acceptable to Public Utilities Department. Existing laterals or services shall be rerouted to a location acceptable to the owners and reconnected to the new main. Upon acceptance of such relocation, the existing main and the easement shall be abandoned. All costs of such relocation work shall be the responsibility of the requesting party.

In certain exceptional cases, it may be possible to construct a permanent structure within a sewer easement. A design deviation request (ATTACHMENT 2) shall be submitted for approval by the Senior Civil

Engineer and PUD. If the encroachment is allowed, the existing main shall be replaced in place in a protective, reinforced concrete casing acceptable to PUD. For sewers at standard depths (6 to 10 feet) the casing shall extend a minimum of 15 feet beyond the encroaching structure to allow excavation and pipe replacement without jeopardizing the structure. Additional casing or easement width may be required to allow for an adequate construction zone. Load calculations shall be prepared by a registered civil engineer demonstrating that the casing will withstand all transmitted loads. This alternative applies only to encroachments with a maximum length of 200 feet and where there are no lateral connections. In addition, the structure shall not be located on top of a manhole or other appurtenances (valve, vault, etc.) nor shall it impede access to these facilities. Typical structures which may be allowed include detached carports, fountains, kiosks, patios, and other non-habitable facilities. The casing shall be the diameter of the main plus 12 inches (min. 24 inches) with full height skids and end seals to fix the pipe invert to the correct grade. In such cases, the Senior Civil Engineer shall analyze and assess the potential damage that may be caused by future breaks. If the assessed value is too high, then the encroachment will not be permitted. In all cases where the encroachment is approved, an Encroachment, Maintenance and Removal Agreement (EMRA) shall be required.

3.3.3 **Other Encroachments**

3.3.3.1 General Landscape

Planting or seeding over sewer mains located within open space or Environmentally Sensitive Lands (ESL) shall be as follows:

- a. No trees shall be planted within 10 feet of any sewer main or lateral.
- b. No shrubs that mature over 5 feet in height shall be planted within 5 feet of any sewer main or lateral.

3.3.3.2 Threatened or Endangered Plants

No threatened or endangered* plant species shall be planted or seeded on sewer access paths, within 3 feet of the edge of access paths, or within 10 feet of sewer mains or lines.

*As described by the U.S. Fish and Wildlife Service
<http://www.fws.gov/endangered>
and by the California Department of Fish and Game
<http://www.dfg.ca.gov/biogeodata/cnddb/pdfs/TEPlants.pdf>

3.3.3.3 Landscape for Access Paths in Environmentally Sensitive Areas

Trees or shrubs that mature over 3 feet in height shall not be planted on the sewer access paths and shrubs that will overgrow the access paths shall not be planted adjacent to the edges of the path area. Planting on the paths must be

consistent with the approved planting palette included as ATTACHMENT 4. Additional or alternate plant species not included may be approved by the Environmental Section, Public Utilities Department.

3.3.3.4 Encroachment, Maintenance and Removal Agreement (EMRA)

Lighting poles, power conductors, pressurized water lines, retaining walls and other encroachments shall be limited and approved by the Senior Civil Engineer of Water and Sewer Development Review, Public Utilities Department. These facilities shall be clearly shown on the public improvement plans. If approved, these encroachments shall require an Encroachment, Maintenance, and Removal Agreement (EMRA).

3.4 EASEMENT RESEARCH

All easements are granted by a subdivision or parcel map, "granted hereon", or by "B" sheet, "C" sheet, or "D" sheet City drawings. These maps and documents are recorded at the Office of the County Recorder and they become public record. The DESIGN ENGINEER may also research the grant deed title by either a map or a document that confirms the existence of an easement.

3.4.1 Easements Granted by Subdivision or Parcel Map

Easements granted by map can be confirmed by using the following steps:

- a. The 100 scale base map shall be reviewed to obtain the legal description (Lot, Block, and Map No.) of the subject property.
- b. A copy of the subdivision or parcel map shall be obtained from the Engineering Maps and Records Section of the Land Development Review Division. Subdivision maps are filed in numerical order under "S"; parcel maps under "H".
- c. The subject area shall be located on the map and whether the easement is on the map shall be determined. The easement may be noted as "granted hereon" or "existing". Existing easements shall be identified with the granting source reference (deed recording information or previously recorded map number).

If the subject easement is not shown on a map, the easement may still exist, especially in older areas of the City that were subdivided prior to utility (sewer) installation.

3.4.2 Easements by Grant Deed

Easements by grant deed sometimes require extensive research, including one or more of the following procedures:

3.4.2.1 Search by the City Clerk

When an easement is accepted by the City, it is processed by the City Clerk and receives a resolution number. Recent information (since 1945) is on a computerized index and can easily be retrieved by providing the legal description (subdivision name and lot number) or the grantor's name, "while you wait." The City Clerk has personnel to provide information and perform searches. For lengthy searches (non-computer), there is typically a backlog on a first-come first-served basis (expect to wait at least 6 weeks for a response). For interdepartmental search inquiries, there is a standard request form to fill out which includes the name, department, and phone number of the requestor. The more information provided, the more thorough the search will be. As a minimum, the following information will be required:

- a. Legal description of the property
- b. Name of owner(s) and date(s) contained on the "Sewer Connection Order" for the property's sewer lateral. This information is filed by "Tap No." at Water Operations Maps and Records. The tap numbers for the sewer laterals are shown on the "100 scale" sewer base maps. These maps can be viewed on the third floor of the Development Services Center or by appointment with Water and Sewer Development Review, Public Utilities Department.

3.4.2.2 Improvement Plan Inspection for Easements

The DESIGN ENGINEER shall obtain improvement drawing numbers for existing improvements from the "100 scale" sewer base maps and/or from other record information, e.g. reference drawings. Reference drawing information may be found by using the index. Listings are alphabetical and by Lambert coordinate location.

Easements or rights-of-way that are shown in the plan view on an improvement drawing for reference and information as "B" sheet easement plats are not always recorded easements and are missing easement recording information. "B" sheet plats may exist for easements that were never acquired. However, there is a greater chance of there being an easement when the number of a "B" sheet is shown on the plans than when there is not. Make a note of the "B" sheet number shown on the improvement plans or the easement plat number for later use in the title search and also note the date of easement acquisition.

3.4.2.3 Search at the County Recorder

The County Recorder is located in the County Administration Building at 1600 Pacific Highway. All recorded documents are on file there. The

documents are indexed chronologically by recording date/document number (e.g. 73-345678) and alphabetically by grantor and grantee name. To begin a search for a particular easement grant deed, the DESIGN ENGINEER will need to know one or more of the following:

- a. Document number and recording date
- b. Grantor name, former owner of the property (Grantee is the City of San Diego) and the approximate date of easement acquisition.

In performing the easement search, look through old microfilmed documents for one which encumbers the subject property. The search can be lengthy and time consuming, but knowing the document number and recording date makes the job easier. However, just because the easement does not appear on the current grant deed, it does not necessarily mean that the easement does not, or never did, exist. It may have been overlooked by the title insurance search and not transferred to the current grant deed. If information is not known about the past owners or potential easement grantors, start with the current ownership and perform a "title search" to identify past ownership. The current owner will be on file at the County Assessor's Office. Ownership information is available either via the City's mainframe computer system or over the phone, given the assessor's parcel number for the property. The grant deed recording information is also available. The name of the previous owner (grantee of the property) is obtained by inspection of the grant deed.

Exhibit 3-1 Sewer Access Roads - New Sewers in Environmentally Sensitive Lands

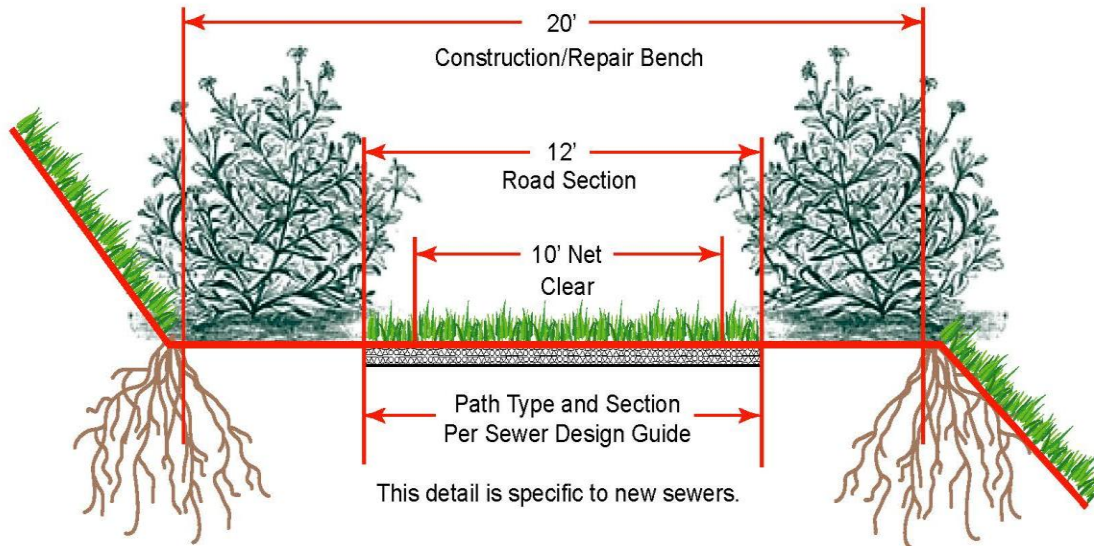

Note 1: Within 20' bench and over access road hydroseed with plants per Attachment 4.

Note 2: Within areas beyond the 20' bench plant shrubs and non grass plants so mature plants will overhang road by no more than 12". Shrubs & plants that do not conform to attachment 4 shall be hand placed from containers & pots. After landscaping matures, the net road shall be 10' clear. No shrubs will be planted within the 20' bench.

- 12' improved road type and section per PUD Sewer Design Guide.
- The road shall be centered over the sewer where possible.

Plant material shall be chosen that best matches adjacent vegetation.

**This road is designed to support the maneuverability of vector type equipment, which has the same turning radius and loading requirements as a full fire engine.*

***Requires separate Environmental Permit.*

Exhibit 3-2 Sewer Access Paths - Existing Sewers in Environmentally Sensitive Lands

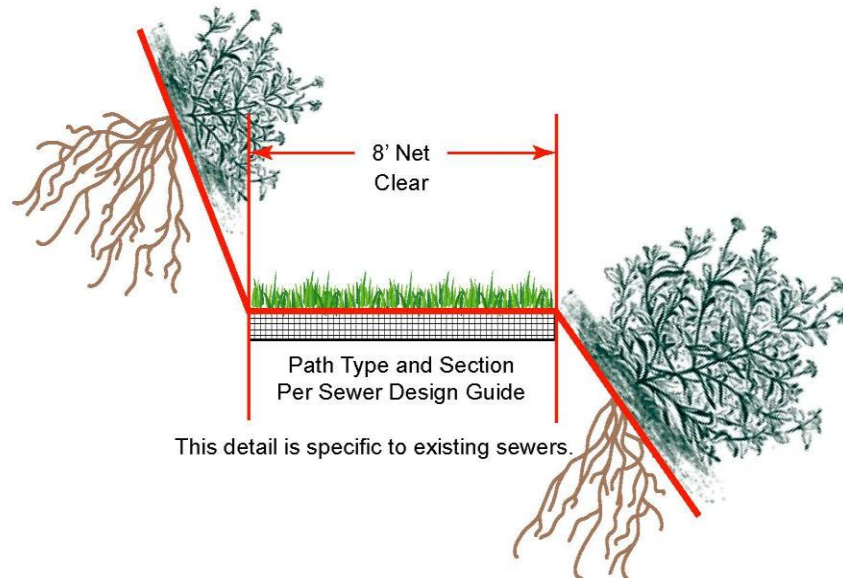

Note 1: Within 8' path apply woodchips or hydroseed with low growing native plants per Attachment 4.

Note 2: Within impacted areas beyond the access path, seeds and plants in containers or pots shall be hand placed, so that plants when mature will not overhang the access path.

- 8' improved path type and section per PUD Sewer Design Guide; 8' net path after landscape matures.

Plant material shall be selected that best matches adjacent vegetation.

**This path is designed to support low impact vehicles for access to manholes and mains for replacement.*

***Must conform to Environmental Impact Report RRs 299710 and 299712.*

CHAPTER 4 SEWER MAIN BRIDGE CROSSING DESIGN**4.1 GENERAL**

This Chapter addresses the design requirements for sewer mains built in bridge crossings, acceptable materials, and special items to be considered in utility bridge crossings. Corrosion control requirements may be found in Chapter 6.

4.2 PERMITS**4.2.1 City**

A City Encroachment Maintenance and Removal Agreement (EMRA) will not be required for installation of City maintained sewer pipelines and related utilities on City-owned bridges. However, compliance with these guidelines for pipeline installation on bridges will be required. Coordination between the bridge DESIGN ENGINEER and the Senior Engineer of Wastewater Collections, Public Utilities Department, is essential. Pre-design meetings shall be arranged prior to making any final design recommendation on a bridge project.

4.2.2 CALTRANS

A CALTRANS Encroachment Permit will be required for installation of any sewer pipelines and related utility on a CALTRANS bridge. This will require conforming to the requirements of the latest edition of the "CALTRANS Manual of Encroachment Permits, Encroachments on Bridges."

4.3 PIPELINE CONSTRUCTION**4.3.1 General Design****4.3.1.1 Design Considerations**

As part of the evaluation of sewer pipelines at bridge crossings, the DESIGN ENGINEER shall consider safety, aesthetics, accessibility, maintenance and environmental impacts. Consider the use of alternative pipeline locations and configurations, such as routing the pipeline around the bridge or using multiple smaller diameter pipes to adapt to the physical conditions of the site, hanging pipes between two adjacent bridges, and placing the pipes in a sleeve, etc.

4.3.1.2 **Standard of Design**

Use proven, tested engineering and design and construction standards to increase reliability and maintainability and to decrease repair frequency.

4.3.1.3 **Pipeline Requirements**

The DESIGN ENGINEER shall evaluate and determine the appropriate increased factor of safety for the various utility components at the crossing to account for the increased risks of utility bridge crossing. For example, increase the pressure class and wall thicknesses required for the design pressure to provide additional pipe strength and sacrificial wall material and/or provide piping materials suitable for point support and direct exposure (not buried).

4.3.1.4 **Future Expansion**

Pipeline facilities in bridges shall be sized to accommodate future needs or provide a pipeline casing to facilitate future expansion. Where required for redundancy, provide multiple pipeline casings.

4.3.1.5 **Spare Pipe in Closed Cell Bridges**

A section of spare pipe shall be provided in each cell of closed cell (box girder-type) bridges (Figure 4-1). Seal both ends of extra pipe lengths to prevent accumulation of debris inside the pipe. The spare pipes shall be placed on wood cradles in an accessible location.

4.3.1.6 **Gravity Main Manhole Requirements**

Gravity mains shall have manholes on each end of the bridge. Manholes shall be within 25 to 40 feet beyond the end of the bridge and outside the approach slabs.

4.3.1.7 **Force Main Isolation**

Force mains shall have isolation shut-off valves on each end of the bridge and each valve shall be located in a vault. Shut-off valves are required to be within 25 to 40 feet beyond the end of the bridge and outside the approach slabs. The shut-off vault at the low end of the bridge shall include a blow-off so that the entire section of the isolated main can be drained. The isolation vault shall be located in an area accessible by vector trucks for maintenance.

4.3.1.8 Access Vaults and Sleeves

Sleeves through abutments and bridge sections shall be sized to accommodate all pipe sections and fittings installed within the bridge. The number of sleeve openings shall accommodate the ultimate buildout design plus an additional unplanned future pipe. Access vaults at each abutment shall be designed and sized to accommodate the ultimate number of pipes planned for the bridge.

4.3.2 Pipeline Location

Pipelines and appurtenances shall be located under the shoulder or sidewalk area (i.e., between the exterior and first girder; see Figures 4-1 and 4-2).

In box girder type bridges, no other utilities shall be installed in the same cell as sewer pipelines and appurtenances.

For slab type bridges, sewer mains shall be suspended beneath the structure near the outer edge of the bridge or deck where vertical clearance or freedom of movement for personnel and equipment is available (Ref. Figure 4-3). Where this is not possible, provisions shall be provided for ready access with scaffolding from underneath the bridge. On dual bridges, sewer mains shall be suspended along the outside of the structure between the bridges (Ref. Figure 4-4). Dual bridges shall be separated sufficiently to accommodate suspended scaffolding for maintenance and repairs.

4.3.3 Access Requirements

Open girder type bridges shall be designed with pipelines located near the edge to provide for inspection and maintenance from the bridge deck with mobile truck mounted equipment or permanent scaffolding (Ref. Figures 4-2 and 4-3).

In box girder-type bridges, provide entry access for materials and equipment for operation, inspection, maintenance, and repair of all pipelines and appurtenances. Refer to bridge type details (Figure 4-1) for notes on access requirements.

Access hatches for pipelines shall be at least 2 ft x 3 ft (Ref. Figure 4-1) oriented with the long axis parallel to the pipe. Provide a minimum of two access hatches per bridge cell for future pipelines per Subsection 4.3.1.8. The access hatches shall be located at each end of the cells for confined space worker escape. Measures shall be provided to prevent unauthorized access to pipelines.

Where adequate access to utilities can be provided for maintenance, pipelines and appurtenances shall not be exposed to view.

4.3.4 **Loading Considerations**

Pipelines shall be designed for all imposed loads. Calculations shall include checks for internal pressure, hydraulic transients, seismic, and wind loads. Longitudinal deflection shall be limited to $L/360$. All thrust forces shall be calculated and resisted. Maximum thermal expansion and contraction shall be calculated and accommodated. Check bending, shear, and local buckling at supports.

Design to accommodate differential movement between bridge and pipeline materials due to traffic loading, thermal expansion, seismic loading, long term deflection (camber), etc.

Provide expansion joints to accommodate relative expansion and contraction between the bridge and the pipeline, typically resulting from thermal effects. Since this type of movement is only in the axial direction, angular or translational movement expansion joints shall be anchored at one location, with the remaining supports allowing axial movement. Pipelines shall be anchored at all bends, valves, tees, and other thrust producing fittings with expansion joints located appropriately.

Provide flexible joints to accommodate differential settlement, rotation, and axial movement between adjacent sections of pipeline where such movement is expected. This type of movement is expected at the junction between bridge and abutment (Ref. Figure 4-5), between abutment and embankment, and between soil masses with differing compaction, loading, and settlement characteristics. The DESIGN ENGINEER shall provide a basis of any design reports and design calculations.

Confirm that pipelines in the vicinity of an abutment to an embankment transition are capable of accommodating large amounts of differential movement. Submit all calculations with plans to the City Project Manager or plan reviewer.

4.4 **PIPELINE MATERIALS**

4.4.1 **Pipe Requirements**

4.4.1.1 **Ductile Iron Pipe:** Ductile iron pipe shall conform to AWWA C150 and C151. Pipe shall be coated and lined in accordance with Chapter 6.

4.4.2 Pipeline Casing

If a pipeline passes over a freeway, primary road or railroad, it must be enclosed in a casing. A box girder cell (Ref. Figure 4-1) may be considered in lieu of the encasement if access is available for the full length of the pipeline in the bridge, the pipeline is constructed of metal pipe, and provisions are made to adequately drain the cell in the event of pipe rupture. Special attention shall be given to pipelines under pressure.

The casing shall extend beyond the abutment and the backfill area such that any leakage in the pipe will not flow under or around the bridge abutments or approach slabs. The casing shall be sealed at the higher end with provision for drainage at the lower end.

4.4.3 Available Joint Types and Characteristics

4.4.3.1 **Flanged Connection:** Flanged joints provide complete restraint against all movement; however, they have no tolerance for misalignment.

4.4.3.2 **Push-on Joint:** (For example: Tyton, Fastite, etc.). Push-on joints do not provide restraint against axial movement. Restraint against axial movement can be provided by using special configurations and accessories. These configurations typically also prevent angular and translational movement and thus are not suitable where movement other than axial is desired. Tolerance for misalignment is limited and in accordance with the manufacturer's specifications. Many of the special configurations require special bell end casting as well, thus special pipe purchases are required.

4.4.3.3 **Mechanical Joint:** Mechanical joints do not provide restraint against axial movement. Restraint against axial movement can be provided by using special gasket retainer glands, e.g. EBAA Iron's Megalug, or other special configurations, e.g. Pacific States' Lock Mechanical Joint. These configurations typically also prevent angular and translational movement as well, and thus are not suitable where movement other than axial is desired. Tolerance for misalignment is limited and in accordance with the manufacturer's specifications.

4.4.3.4 **Restrained Push-on Joint:** (For example: Super-Lock Tyton, Restrained Tyton, Boltless Restrained Fastite, TR-Flex). Restrained push-on joints provide restraint against axial movement, with allowance for limited angular and translational movement. No expansion capability exists. Tolerance for misalignment is limited and in accordance with the manufacturer's specifications.

4.4.3.5 **Ball and Socket Joint:** (For example: USIFLEX, Clow River Crossing Pipe). Ball and socket joints provide restraint against axial movement with allowance for large angular movement. When two or more joints and an expansion joint are provided, the system can accommodate large translational movement including expansion and contraction capabilities. Several manufacturers provide a combined unit consisting of two ball joints and an expansion coupling between the two ball joints. This combined unit or flexible joint system has good allowance for misalignment.

4.4.4 **Joint Application Considerations**

4.4.4.1 **Joints for Ductile Iron Pipe:** Restrained joints may be flanged type, or of other types with appropriate restraint features. If joints restrained against axial movement are used on bridges, the pipeline must be properly anchored and equipped with expansion joints. Intermediate supports must allow axial movement.

Sleeve couplings or mechanical and push-on joints may be used on bridges if each length of pipe is anchored. Joints must be capable of accommodating the expansion and contraction of each length of pipe and must not be restrained. Anchor supports shall be located at the bell end of the pipe. Intermediate supports must allow axial movement.

4.4.4.2 **Expansion Joints:** Expansion joints may be the bellows type, slip type with stainless steel packing bellows, or elastomeric, if available in the proper size, pressure class, and desired movement capability. Expansion joints shall not require limit rods (long bolts spanning the joint) if pipeline sections are properly anchored and single end expansion joints are used. Expansion joints for pipelines carrying sewage shall be designed to avoid trapping solids. Piping on either side of expansion joints shall be properly supported to minimize stresses on the expansion joint itself. A support directly below the expansion joint may be required.

4.4.4.3 **Joints at Transitions:** Bellows type expansion joints may provide sufficient angular and translational movement capability for use at the bridge to abutment transition, if not restrained against movement in those directions.

The pipeline in the vicinity of the abutment to embankment transition shall be capable of accommodating large amounts of differential movement. Where a casing is required, the casing shall provide sufficient rigidity to prevent pipe damage and a flexible coupling shall be provided at the end of the casing. Where a casing is not provided, multiple flexible couplings or an expansion joint with ball and socket river crossing joint at each end shall be provided.

4.4.5 **Cathodic Protection**

Pipelines shall comply with all corrosion control requirements in Chapter 6.

All ductile iron pipeline sections shall be made electrically continuous to facilitate future installation of cathodic protection for the pipeline. Wax tape coating system shall be provided for each ductile/cast iron fitting on PVC piping. For additional corrosion protection information, please refer to Chapter 6.

4.5 **SUPPORTS**

Spacing of pipeline supports is dependent on the beam strength and rigidity of the pipe material and on bearing considerations at the supports. Supports must be designed to provide anchorage or axial movement, as required by pipeline construction (see Figures 4-6, 4-7, and 4-8). Supports must be equipped with rollers or pipe saddles which can be lubricated. A support shall be located within five (5) feet of each abutment.

Provide neoprene and separate Type 316 stainless steel plate saddle supports to electrically isolate the pipe from the bridge, in case pipeline cathodic protection is provided as part of the immediate or future project.

Design and set supports to maintain pipeline grade to provide free draining conditions and avoid sags that trap pockets of liquid or air in the pipeline.

4.6 **OTHER DESIGN CONSIDERATIONS**

The inside diameter of penetrations and casings through pier caps, pile caps, abutments, or other transverse structural components of the bridge shall be at least 8 inches larger than the largest pipe dimension (including bells or flanges, etc.), including considerations for future required pipe sizes.

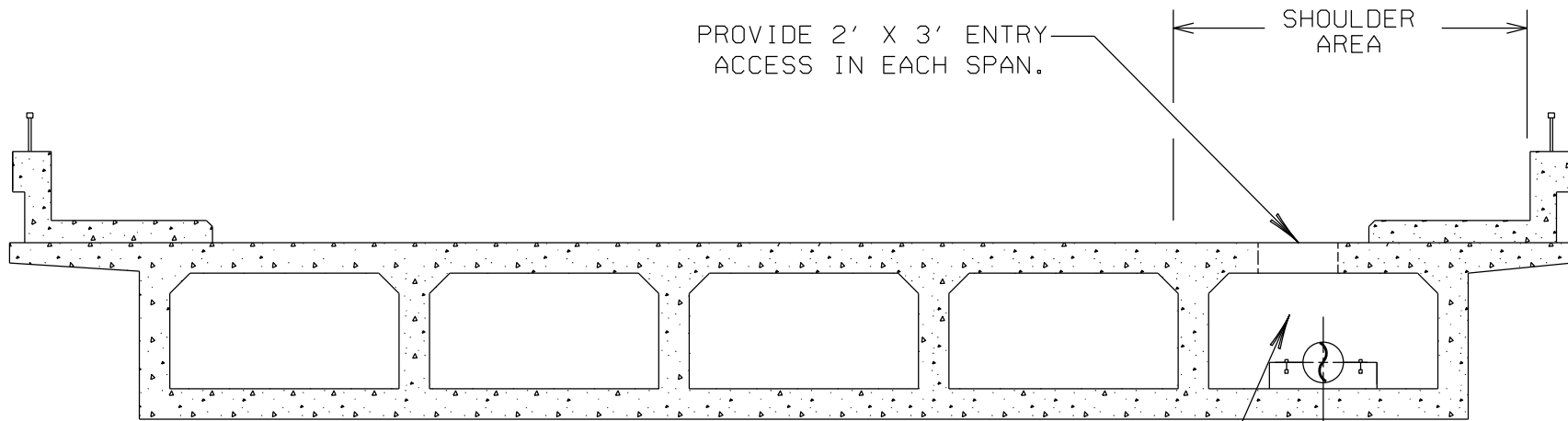

LOCATE PIPELINE WITHIN CELL IN SHOULDER AREA

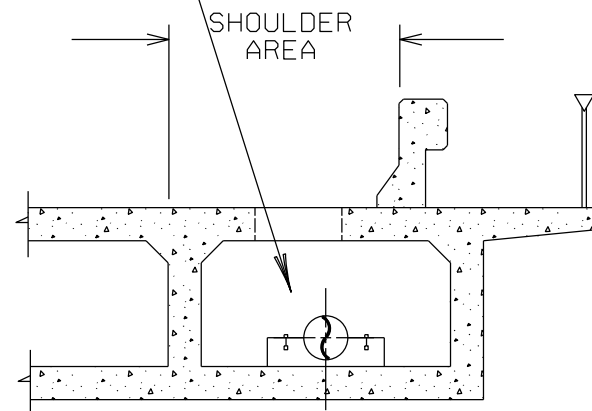

NOTE :

ALL DETAILS SHOWN FOR ILLUSTRATION ONLY. DESIGNER SHALL ASSUME RESPONSIBILITY FOR COMPLETE AND ADEQUATE DESIGN OF ALL COMPONENTS.

NOTE ON PLANS :

ALL FORMING MATERIALS AND DEBRIS SHALL BE COMPLETELY REMOVED FROM CELLS WHICH CARRY WATER AND SEWER MAINS.

SEWER MAIN INSTALLATION IN BOX GIRDER-TYPE BRIDGE

FIGURE 4-1

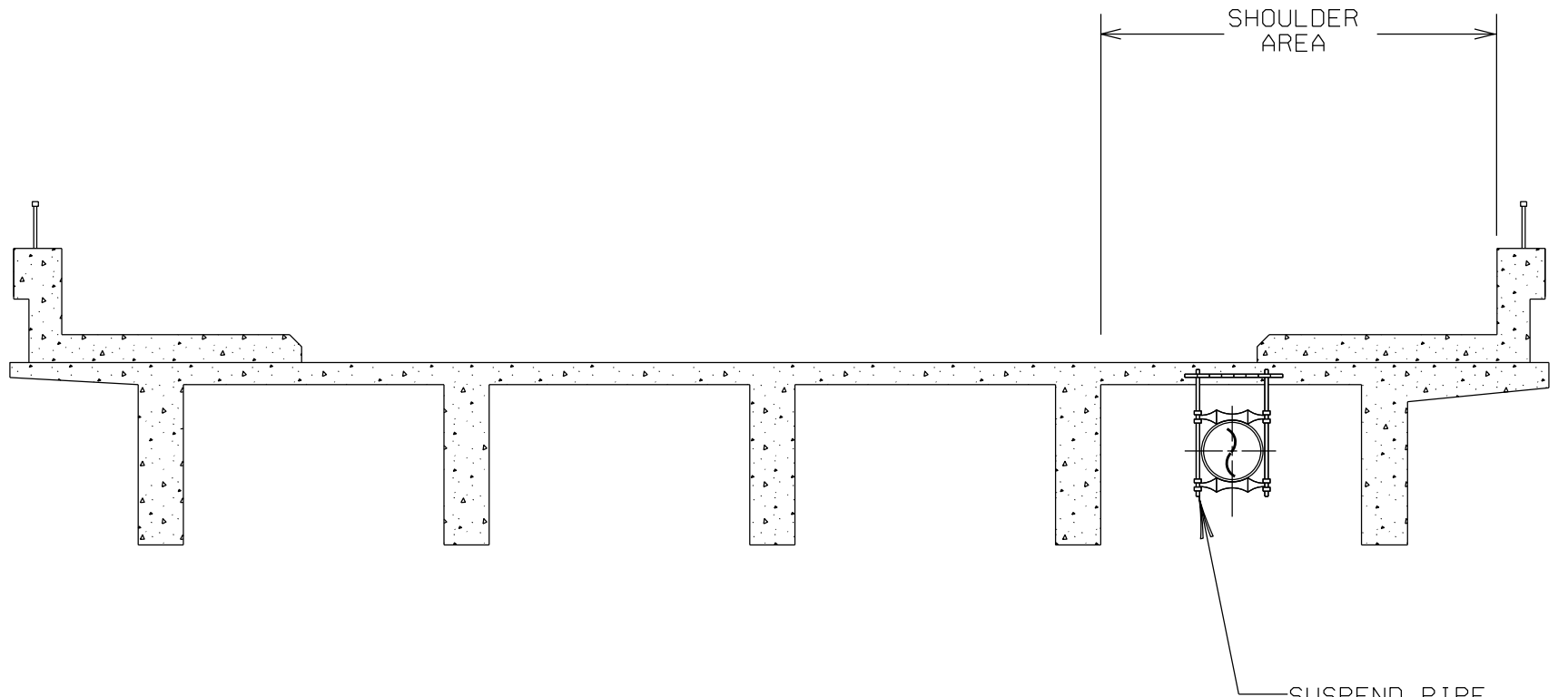

NOTE :

ALL DETAILS SHOWN FOR ILLUSTRATION ONLY. DESIGNER SHALL ASSUME RESPONSIBILITY FOR COMPLETE AND ADEQUATE DESIGN OF ALL COMPONENTS.

SUSPEND PIPE
BENEATH BRIDGE
IN SHOULDER AREA.

**SEWER MAIN INSTALLATION ON
OPEN GIRDER-TYPE BRIDGE**

FIGURE 4-2

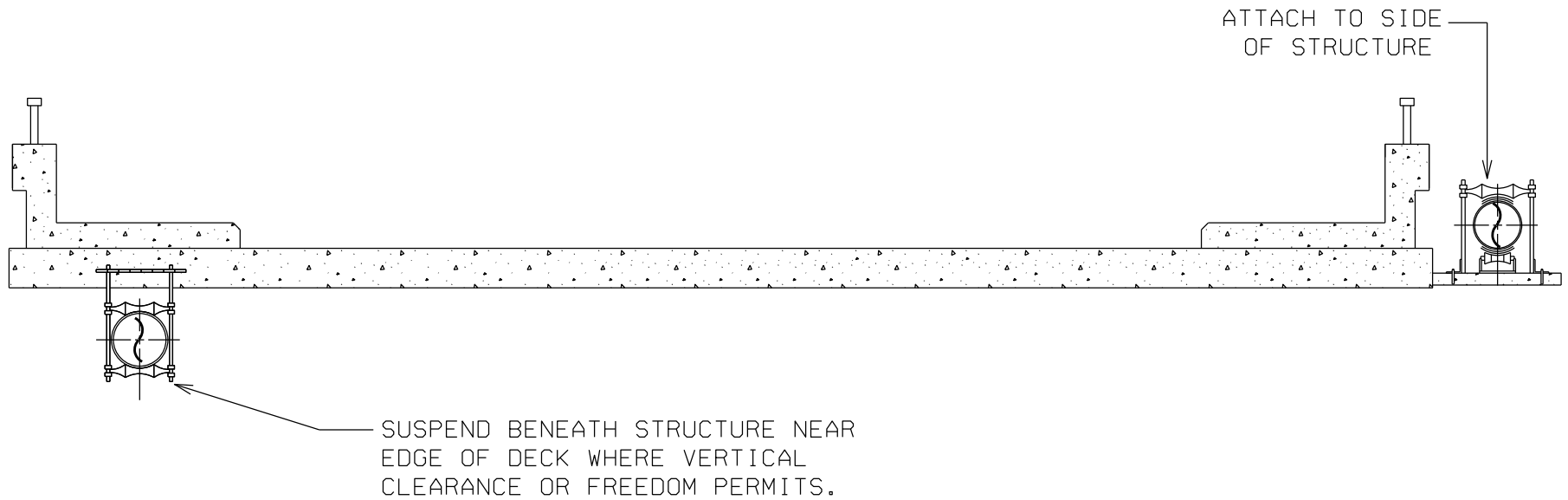

NOTE :

ALL DETAILS SHOWN FOR ILLUSTRATION ONLY. DESIGNER SHALL ASSUME RESPONSIBILITY FOR COMPLETE AND ADEQUATE DESIGN OF ALL COMPONENTS.

**SEWER MAIN INSTALLATION
ON SLAB TYPE BRIDGE**

FIGURE 4-3

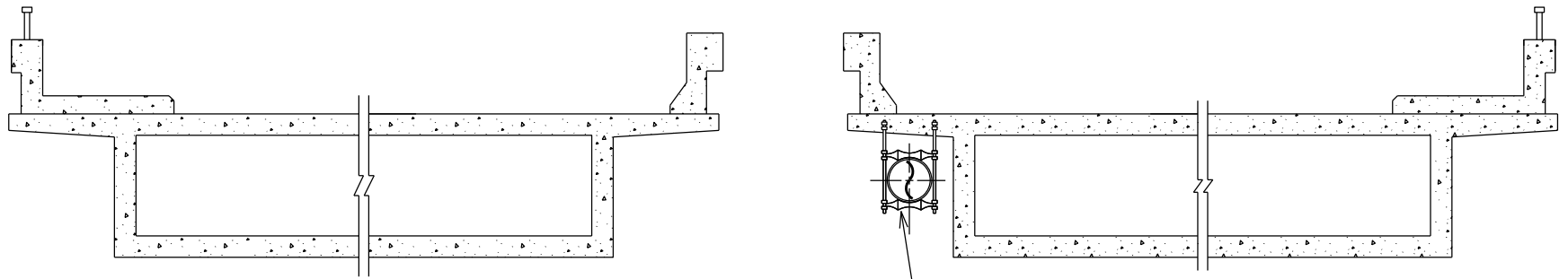

SUSPEND PIPE LINE ALONG OUTSIDE OF
STRUCTURE BETWEEN DUAL STRUCTURES.

NOTE

ALL DETAILS SHOWN FOR ILLUSTRATION ONLY. DESIGNER SHALL
ASSUME RESPONSIBILITY FOR COMPLETE AND ADEQUATE
DESIGN OF ALL COMPONENTS.

**SEWER MAIN INSTALLATION ON
DUAL BRIDGES (ALL TYPES)**

FIGURE 4-4

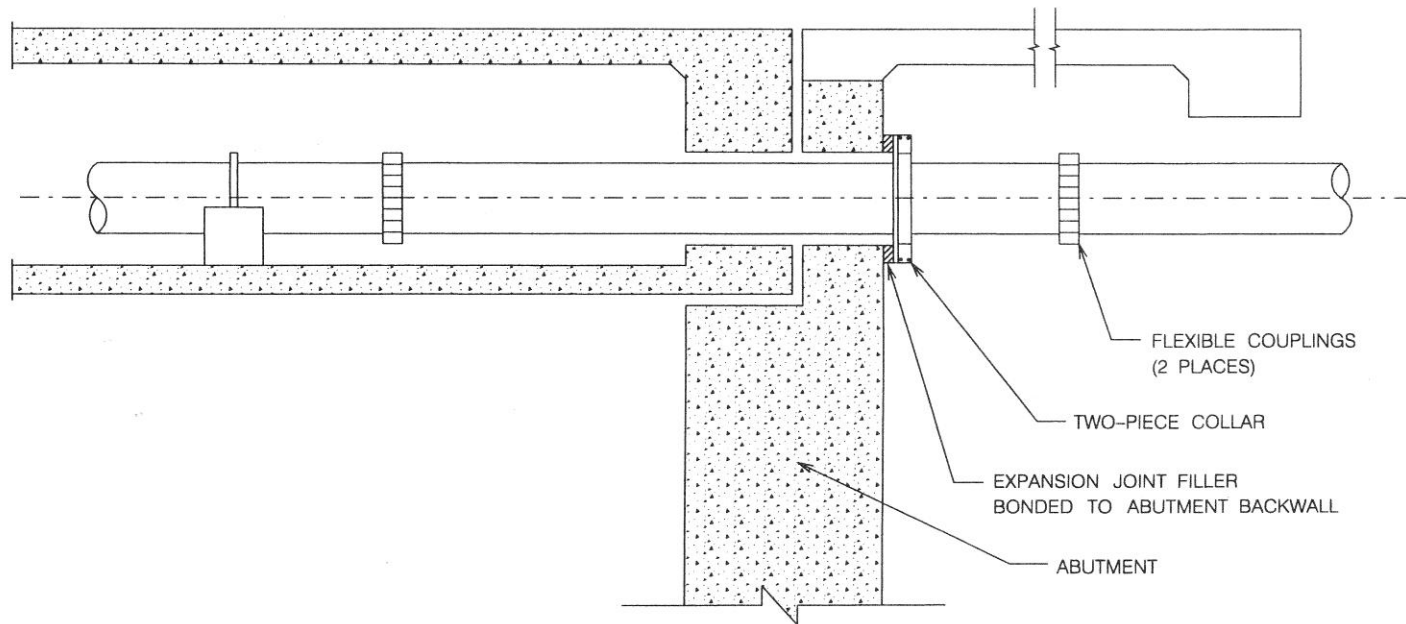

NOTE:

ALL DETAILS SHOWN FOR ILLUSTRATION ONLY. DESIGNER SHALL ASSUME RESPONSIBILITY FOR COMPLETE AND ADEQUATE DESIGN OF ALL COMPONENTS.

ABUTMENT DETAILS

FIGURE 4-5

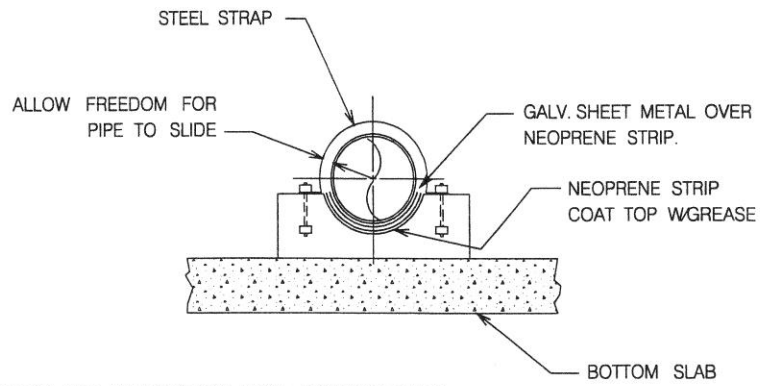
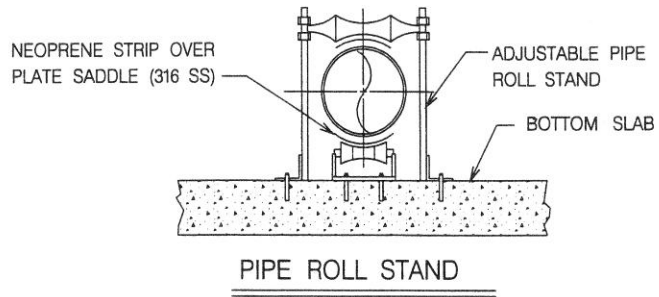
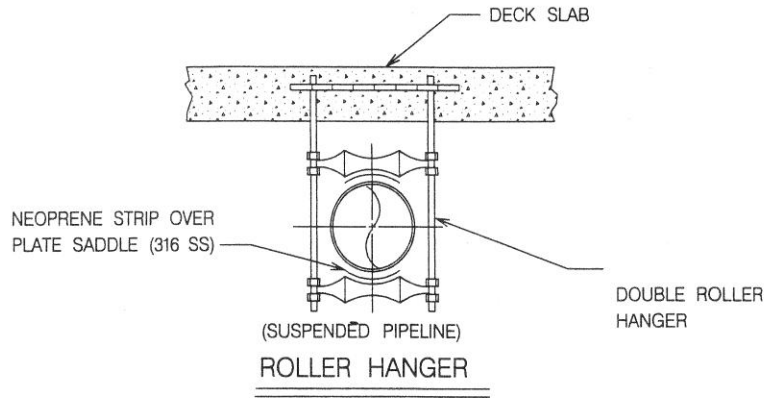

NOTE:

ALL DETAILS SHOWN FOR ILLUSTRATION ONLY. DESIGNER SHALL
ASSUME RESPONSIBILITY FOR COMPLETE AND ADEQUATE
DESIGN OF ALL COMPONENTS.

PIPE SADDLES

FIGURE 4-6

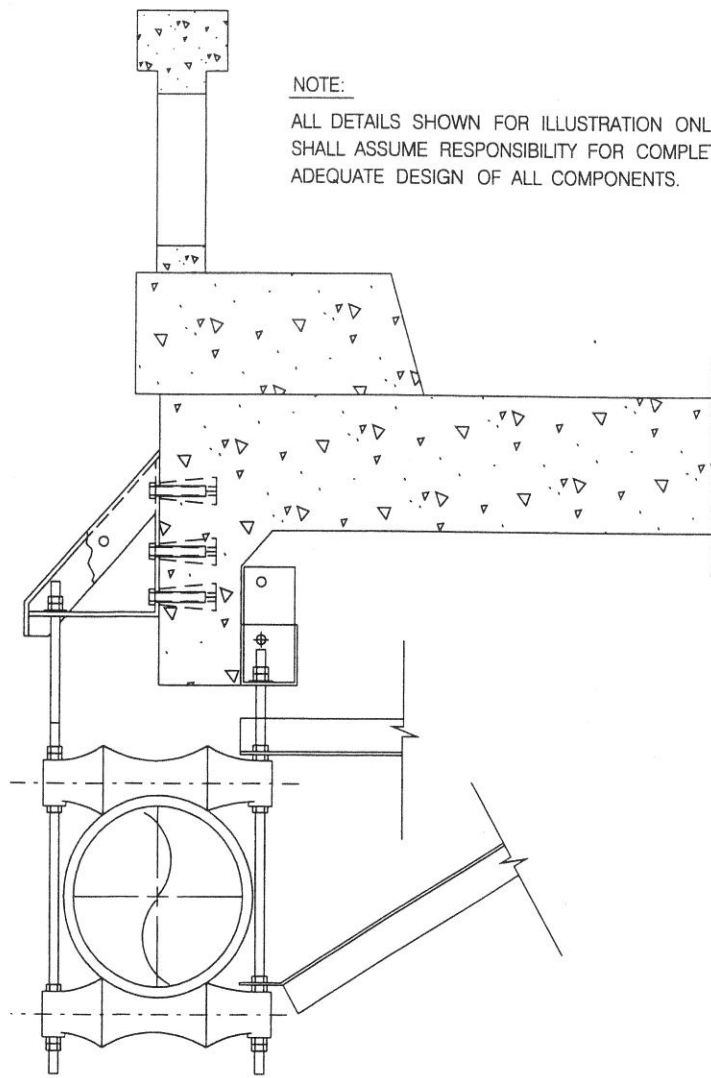

NOTE:

ALL DETAILS SHOWN FOR ILLUSTRATION ONLY. DESIGNER SHALL ASSUME RESPONSIBILITY FOR COMPLETE AND ADEQUATE DESIGN OF ALL COMPONENTS.

**MERCY ROAD BRIDGE
WATER TRANSMISSION LINE**

FIGURE 4-7

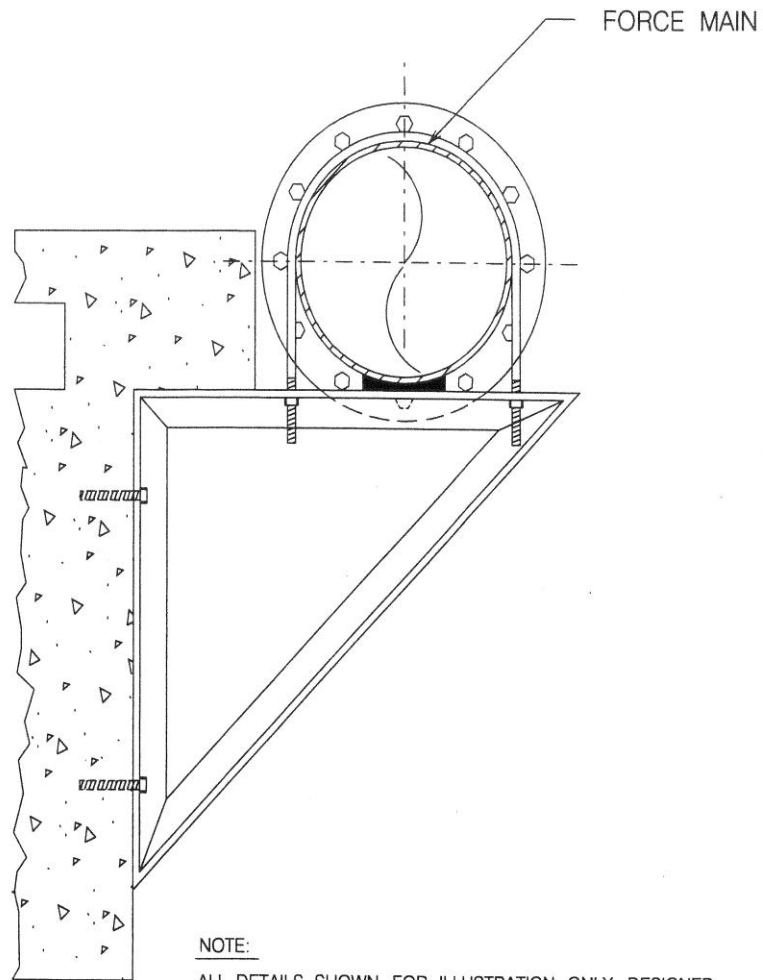

NOTE:

ALL DETAILS SHOWN FOR ILLUSTRATION ONLY. DESIGNER SHALL ASSUME RESPONSIBILITY FOR COMPLETE AND ADEQUATE DESIGN OF ALL COMPONENTS.

**ROBINSON AVENUE BRIDGE
16" FORCE MAIN**

FIGURE 4-8

**CHAPTER 5 ABANDONMENT OF EXISTING SEWER MAINS,
MANHOLES AND EASEMENTS**

5.1 GENERAL

This chapter addresses the requirements for abandonment of existing sewer facilities and easements. Abandonment of any existing sewer facilities or easements, including stubs or dead end mains, requires the approval of the Senior Civil Engineer, Wastewater Collection Division, Public Utilities Department.

5.2 ABANDONMENT OF SEWER FACILITIES

Existing sewer mains and manholes shall be abandoned in accordance with the provisions of the most current edition of the *Standard Specifications for Public Works Construction*. (“GREENBOOK”)

In addition to “GREENBOOK” requirements, all abandoned mains shall be sand or slurry filled for their entire length. As an alternative, where mains will be removed by future construction, the owner may record a Subterranean Facility Abandonment Agreement (see Figure 5-1) with the County Recorder for each affected lot.

All sewer facilities to be abandoned shall be clearly shown on an approved set of public improvement plans and clearly labeled as “To Be Abandoned.” On each sheet of the plans whereon sewer facilities are to be abandoned, Table 5-1 shall be shown on the plans and completed.

TABLE 5-1
SEWER MAIN ABANDONMENT

SYMBOL	SIZE	TYPE	LENGTH	YEAR INSTALLED

5.3 **ABANDONMENT OF SEWER EASEMENTS**

In cases where sewer facilities are proposed to be completely relocated or abandoned from any existing sewer easement, and there are no other sewer facilities using or contemplated in the future for the easement, the sewer easement shall be abandoned per Section 125.1001 of the Municipal Code as part of the work to be done. Where sewer facilities are to be completely relocated or abandoned from any mixed-use or general utility easement, the easement shall be abandoned per Section 125.1001 of the Municipal Code as part of the work to be done if it is determined that there are no other utilities using or contemplated in the future for the easement. This requirement for easement abandonment shall apply to all private development projects and Capital Improvement Projects.

All easements required to be abandoned shall be accomplished through a Process 5 easement abandonment application with the Development Services Department pursuant to the State of California Streets and Highways Code or, if applicable, pursuant to the Subdivision Map Act.

As part of the easement abandonment process, the proposed abandonment shall require the approval of the Senior Civil Engineer of Wastewater Collection Division, Public Utilities Department.

FIGURE 5-1

RECORDING REQUESTED BY:

City of San Diego

AND WHEN RECORDED MAIL TO:
THE CITY OF SAN DIEGO
DEVELOPMENT SERVICES
Land Development Review Division
1222 First Avenue, M.S. 502
San Diego, CA 92101-4155

(THIS SPACE FOR RECORDER'S USE ONLY)

Subterranean Facility Abandonment Agreement

W.O. _____

COORD. # _____

The undersigned, the owner of _____
(Legal Description)
in the City of San Diego, County of San Diego, State of California, in consideration of the grant of permission by the City of San Diego to
abandon the improvements _____
_____ for the use and benefit to the owner's property, over, under and
across the property located at _____ covenants,
and agrees with the City of San Diego as follows:

- (a) This agreement shall run with the land until such time that the facility is removed or filled with grout or sand to the satisfaction of the City Engineer or the City Manager's Representative.
- (b) _____ (Property Owner) agrees to defend, indemnify, protect and hold the CITY, its agents, officers, and employees harmless from and against any and all claims asserted or liability established for damages, injuries, claims or losses to any person or property including injury to property owners employees, invitee, guests, agents, officers, or uninvited visitors which arise out of or are in any manner directly or indirectly connected with this property, including any and all injuries (including personal injury, disability, dismemberment or death), illness loses, loss of or damage to property, damages, claims liabilities or expenses of any kind or nature and all expenses of investigating and defending against same, provided, however, that the property owner's duty to indemnify and hold harmless shall not include any claims or liability arising from the established active negligence, sole negligence or sole willful misconduct of the CITY, its agents, officers, or employees.
- (c) The current property owner and successors in interest must inform any subsequent owner(s) that there is a subterranean void within the limits of the property, so long as this agreement is in effect.
- (d) The owner must fill the void or remove the subterranean facility prior to placing foundations, structures, or other vulnerable improvements over or within the influence of the subterranean facility. The remediation shall be approved by the Building Official.

SEE ATTACHED EXHIBITS

(Date)

(Signature)

(Print Name & Title)

See Dwg. Nos: _____

**For City Engineer
APPROVED:**

By: _____
Deputy

NOTE: NOTARY ACKNOWLEDGES (FOR ALL SIGNATURES) MUST BE ATTACHED, PER CIVIL CODE SEC. 1180 ET. SEQ.

**To request this information in formats for person(s) with disability, call (619)446-5446 or (800)735-2929 (TT)
DS - 201 (02-01)**

CHAPTER 6 CORROSION CONTROL

6.1 GENERAL

The purpose of this chapter is to provide general recommendations for corrosion control. General recommendations for material selection and protective coatings/linings are briefly summarized in Tables 6-1, 6-2, and 6-3 for sewer facilities. More specific recommendations for sewer applications are included in Tables 6-6 and 6-7. These guidelines are intended to be used by the DESIGN ENGINEER in conjunction with the complete version of the Clean Water Program Corrosion Control Guidelines and accepted industry standards and represent a minimum requirement for each circumstance presented. Where field conditions differ from those presented, the DESIGN ENGINEER shall evaluate those conditions and make corrosion control recommendations.

All corrosion control drawings, designs and calculations shall be prepared and signed by a licensed California Corrosion Engineer or a certificated, NACE International Cathodic Protection Specialist (CP-4).

6.2 MATERIAL SELECTIONS AND CONSIDERATIONS

A variety of options are available for eliminating or minimizing possible problems arising from corrosive environments. Selection of appropriate materials for a given service is the most important consideration. It is also possible, in some cases, to modify the environment to which the materials will be exposed. The use of coatings or linings can also be effective in controlling corrosion of materials exposed to corrosive environments. Electrochemical methods such as cathodic protection are also among the alternatives available to the DESIGN ENGINEER for the work. It is also important to provide for monitoring of corrosion activity, where metallic materials are to be used in a corrosive environment.

The following sections summarize information on the selection and performance of various materials to be used for sewer facilities in the Greater San Diego Metropolitan area. Supplemental information is provided in Tables 6-1, 6-2, and 6-3 and in Sections 6.5, "Cathodic Protection", and 6.7, "Coating and Lining", of this chapter.

6.2.1 Concrete

All concrete structures such as pipes, wet wells, and some manholes (Refer to Subsection 2.3.5.3) shall be internally lined with PVC to protect against corrosion. Liners for new concrete installations shall be a mechanically bonded system such as T-Lock and shall be placed with formwork. PVC liners

shall be as specified in the “GREENBOOK”. For existing concrete, a PVC polyurethane bonded product such as Linabond, a spray-on type 100% solids polyurethane or an epoxy coating may be used, depending on the specific application. For more specifics on manholes, please refer to Chapter 2, Section 2.3.

Reinforced Concrete Pipe, 24 Inches or Greater in Diameter:

All reinforced concrete sewer pipe and appurtenant structures shall be PVC lined (see Chapter 2, Figure 2-3) with joint test ports. Pipe shall be lined 360°.

For reinforced concrete pipe installed in soils with elevated chloride ion (>300 ppm) and elevated sulfate ion (>2,000 ppm) concentrations, an external coal-tar epoxy coating shall be applied to the pipe.

6.2.2 Steel

Coatings and linings must be considered for all applications of steel. For buried applications, cathodic protection is recommended for cement-mortar coated steel pipe where soil or groundwater resistivity is less than 10,000 ohm-cm. Cathodic protection of cement-mortar coated steel is required where resistivity is less than 5,000 ohm-cm. Cathodic protection is always required, regardless of soil or groundwater resistivity, on all dielectrically coated steel pipe. Cathodic protection is always required for steel structures continuously or intermittently submerged in raw sewage.

For all exposures, steel should be electrically isolated from dissimilar metals to prevent the formation of unfavorable galvanic corrosion cells.

Steel Pipe 3 Inches and Greater in Diameter: Lining shall be liquid epoxy (AWWA C210), fusion bonded epoxy (AWWA C213) or polyurethane (AWWA C222). Coating shall be cement- mortar (AWWA C205), 3-layer cold applied tape wrap (AWWA C214), liquid epoxy, fusion bonded epoxy, or polyurethane. Linings and coatings shall be compatible with each other.

6.2.3 Ductile Iron

Coatings for buried ductile iron pipe shall be determined on a project by project basis, depending on the specific piping application and soil environment encountered. Loose polyethylene encasement (AWWA C105) may be used when soils have been determined to be mildly corrosive. For moderately corrosive soils, polyethylene encasement and cathodic protection may be considered. For corrosive soils, ductile iron pipe must be coated with a bonded dielectric coating and be installed with cathodic protection. For small scale buried, ductile iron pipe installations, a 3-part, field applied wax-tape coating per AWWA C217 may be considered in lieu of a bonded dielectric coating. All buried ductile iron piping shall be made electrically continuous by the

installation of joint bonds. Depending on the specific project, lining may also be required. Linings for ductile iron pipe can be either cement-mortar, fusion bonded epoxy, polyurethane, or ceramic quartz-filled amine cured novalac epoxy.

Ductile iron pipe which is either continuously submerged or intermittently submerged in raw sewage or exposed to corrosive atmospheres in such locations as wet-wells shall also have a bonded dielectric external coating such as fusion-bonded epoxy.

6.2.4 **Aluminum**

Aluminum is not recommended for use when in contact with soil or process streams. Aluminum is suitable for atmospheric exposure. It may not be used in direct contact with concrete or other high pH environments. There must be physical isolation between aluminum and concrete. Aluminum will corrode in a marine atmosphere unless it is suitably anodized.

6.2.5 **Copper and Brass**

Consideration must be given to coating and cathodic protection of copper and brass used in contact with soil. Care must be taken to prevent direct electrical connection of piping which is operated at different temperatures. Copper and brass must not be used in contact with process streams containing residual chlorine in excess of 2 parts per million (ppm) or in environments with pH less than 5.5.

When copper or brass is used in an aggressive environment, it should be electrically isolated from other structures. Care shall be taken to electrically isolate copper piping from ferrous piping or other dissimilar metal to prevent galvanic corrosion. If copper piping is used for connection of copper service lines to plastic mains, this should be accomplished by using brass tapping saddles.

6.2.6 **Stainless Steel**

Coating and cathodic protection may be considered for stainless steel in soil and water. Stainless steels may be used in most atmospheric exposures and may also be used as hardware for connection to steel. Stainless steel exposed to soil, groundwater and wet environments can experience very rapid corrosion and may be considered when needed where cathodic protection is provided. In these conditions, cathodic protection is ineffective for complex structures, such as overlapping bolted connections and for multiple fittings, due to the probability of very rapid crevice corrosion and, therefore, should not be used.

6.2.7 **Polyvinyl Chloride**

Polyvinyl Chloride (PVC) is suitable for use in buried, submerged and atmospheric exposures. It should not, however, be used in contact with aromatic and chlorinated hydrocarbons, ketones, esters, aldehydes and certain other organics commonly found in leaking underground fuel storage facilities and abandoned chemical storage sites. Soil tests should be conducted prior to

the use of PVC piping in known or suspected areas of contamination. Its use should be limited to temperatures less than 140°F. PVC must be protected from ultraviolet radiation exposure by the use of an appropriate coating system as recommended by the manufacturer. PVC should also not be used in direct contact with concrete backfill or encasements.

6.2.8 Fiberglass

Care should be taken in the use of fiberglass in any piping applications since failures of some products have occurred in the past due to a breakdown of the resins and fibers. This material will not normally be used for sewer piping applications.

6.2.9 Vitrified Clay Pipe

Vitrified clay pipe is suitable for exposure to most soil environments. Care must be taken in using clay pipe because it is brittle. Vitrified clay is the preferred pipe material for concrete encasement or where scour velocities exceeding 10 fps have been approved.

Table 6-1 provides the material selection guide.

TABLE 6-1

MATERIAL SELECTION GUIDE

Material	EXPOSURE					
	Soil		Fluid		Atmospheric	
	C	NC	C	NC	C	NC
Concrete	1	2 or S	1	S	2	2
Steel	1	2	1	2	2	2
Aluminum	NR	NR	NR	NR	S	S
Ductile Iron	1	2	1	2	2	2
Copper/Brass	1	S	NR	NR	NR	S
Stainless Steel	1	2	S	S	S	S
PVC	S	S	S	S	3	3
Other Polymeric Material	S	S	S	S	3	3
FRP ^(a)	S	S	S	S	3	3
Clay	S	S	S	S	NR	NR

(a) See Manufacturer's recommendation for specific requirements.

Legend:

- 1 = Coated and/or Lined & CP
- 2 = Coated Only
- 3 = Must Provide Ultraviolet Protection
- S = Suitable As Is
- C = Corrosive
- NR = Not Recommended for Service
- NC = Non-Corrosive
- CP = Cathodic Protection

Table 6-2 provides the coating selection guide.

TABLE 6-2
COATING SELECTION GUIDE

Material	EXPOSURE		
	Soil	Fluid	Atmospheric
Concrete	CTE	CTE	URE or CTE
Steel	FBE E PWT CMC PU	FBE E PU	URE E
Aluminum	NR	NR	E L
Ductile Iron	PE E FBE PU	E FBE PU	URE E L
Copper/Brass	PWT	NR	E L
Stainless Steel	PWT TWC	CNR	CNR
PVC & Other Polymeric Materials	CNR	CNR	URE (UV Protection Outside Exposure)

Legend:

- NR = Not Recommended for Service
- TWC = Tape Wrap Coating (AWWA C214)

- CTE = Coal Tar Epoxy
- CMC = Cement-Mortar Coated (AWWA C205)
- E = Liquid Epoxy (AWWA C210)
- URE = Aliphatic Urethane (Exterior)
- PU = 100% Solids Polyurethane (AWWA C222)
- L = Latex (Acrylic) (Interior Exposure)
- CNR = Coating Not Required
- PWT = Petrolatum Wax Tape & Filler Paste (AWWA C217)
- FBE = Fusion Bonded Epoxy (AWWA C213)
- PE = Polyethylene Encasement (AWWA C205)

Table 6-3 provides the lining selection guide.

TABLE 6-3

LINING SELECTION GUIDE

Material	Exposure to Sewer
Concrete	PVC, E, PU
Steel	FBE, PU
Aluminum	NR
Ductile Iron	PU, ACNE, FBE
Copper	NR
Stainless Steel	LNR
PVC & Other Polymeric Material	LNR

Legend:

- NR = Not Recommended for Service
- LNR = Lining Not Required
- FBE = Fusion Bonded Epoxy (AWWA C213)
- PVC = Polyvinyl Chloride (T-Lock)
- ACNE = Amine Cured Novalac Epoxy
- PU = Polyurethane (AWWA C222)
- E = 100% Solids Epoxy

6.3 PRE-DESIGN SURVEYS

Corrosion control pre-design surveys are an important aspect with respect to minimizing the adverse effects of corrosion at sewer facilities. Because the corrosion mechanism is most significantly affected by the environment in which the structure is located, it is important that the designer be aware of the anticipated conditions under which the structure will be required to perform. Gathering appropriate and reliable information about the environment will allow determinations to be made as to the corrosive nature of the environment and which materials or corrosion control technique(s) will be most effective and economical.

Pre-design investigations for sewer facilities should begin with the preparation of a soil corrosivity report. The soil corrosivity report should be the basis for the selection of the appropriate piping materials, coatings, and for the determination of the application of cathodic protection for buried piping. At a minimum, the soil corrosivity report should include the following:

- Soil resistivity testing using the Wenner Four-Pin Method
- Laboratory soil resistivity testing of soil samples in the “as-found” and “saturated” states
- Laboratory chemical analysis of soil samples for pH, conductivity, chloride ion concentration, and sulfate ion concentration
- The determination of the existence of cathodic protection systems, or other DC current sources, that may pose a stray current problem

The soil corrosivity report should present conclusions regarding the corrosivity of soil along the project site and provide recommendations regarding materials for buried piping, concrete structures and the application of cathodic protection. For PVC pipe a study of hazardous contamination shall be performed. For vitrified clay no analysis is required.

6.3.1 Soil Resistivity Testing

Predicting corrosion problems associated with buried piping requires the investigation of soil conditions along the pipeline route. Since corrosion of metal is an electrochemical process which, by definition, is accompanied by electric current flow, the electrochemical characteristics of a soil are of primary importance when evaluating corrosivity.

Soil resistivity testing using the Wenner Four Pin Method should be performed along pipeline alignments when ferrous piping is being considered for buried use. Resistivity measurements should be made at a maximum of 1,000-foot intervals along the proposed alignment. Measurements should be taken at various depths to fully capture the resistivity of soil above and below the

pipeline invert depths. Typical pin spacings are usually 2.5, 5, 10, 15 and 20 feet. At a proposed pump station site, measurements should be made in a grid pattern at distances which will provide representative data, but not exceeding 1,000 feet in any direction.

Soil samples should also be obtained at representative locations and at locations of low soil resistivity for laboratory resistivity testing. This testing should be performed in an “as-received” state and in a “saturated” state.

Table 6-4 correlates soil resistivity in ohms-cm with degree of corrosivity.

TABLE 6-4

RESISTIVITY VALUES - CORROSIVITY

Soil Resistivity ohms-cm	Degree of Corrosivity
0 - 1,000	Extremely Corrosive
1,001 - 3,000	Highly Corrosive
3,001 - 5,000	Corrosive
5,001 - 10,000	Moderately Corrosive
10,001 - 20,000	Mildly Corrosive
Above 20,000	Essentially Non-Corrosive

6.3.2 Laboratory Soil Testing

Chemical constituents may also affect the performance of many materials and may often dictate not only the material to be used, but whether or not additional corrosion protection is warranted. At a minimum, soils should be tested for pH, chloride ion concentration and sulfate ion concentration.

Acidic soils, with pH less than 5.5, are considered corrosive to buried steel and concrete structures. Concrete structures (including cement-mortar coated pipe) installed in soils with a pH of less than 5.5, should be installed with a coal-tar epoxy barrier coating.

Elevated chloride ion concentrations can negate the beneficial effects of high pH on buried concrete encased or mortar-coated steel. In soils which contain elevated chloride ion concentrations, additional corrosion protection such as the application of cathodic protection, the addition of silica fume or other corrosion inhibitors, or the application of a barrier coating should be considered.

Soils with high sulfate ion concentrations can also be detrimental to buried concrete encased or mortar-coated steel. Type-V cement should be used on all concrete structures when sulfate ion concentrations in the soil exceed 2,000 ppm. The application of a barrier coating should also be considered for these occasions.

Table 6-5 correlates the effect of chlorides or sulfates on the corrosion of steel or concrete.

TABLE 6-5
CORROSIVE EFFECT OF CHLORIDES OR SULFATES
ON STEEL OR CONCRETE

Degree of Corrosivity	Chloride Concentration (ppm)	Sulfate Concentration (ppm)
Threshold	300	1,000
Positive	300 - 1,500	1,000 - 2,000
Severe	Over 1,500	Over 2,000

6.3.3 Identification of Potential Stray Current Sources

Pre-design investigations must determine the locations of potential stray current sources with respect to the proposed facility. These sources may include, but are not limited to, existing impressed current cathodic protection systems, overhead high voltage AC power transmission lines, and DC light rail transit systems. This information should be considered in the design of new cathodic protection systems, coating selection and corrosion monitoring systems for the proposed facilities.

6.3.4 Stray Currents

Stray current surveys shall be performed on all metallic pipelines and appurtenances to locate power lines and other existing cathodic protection systems that may have an impact on the corrosion protection design of the project pipeline.

6.4 **CORROSION MONITORING AND CATHODIC PROTECTION DESIGN**

All buried, ferrous piping systems must be designed with either a corrosion monitoring system or a cathodic protection system depending on the results of the soil corrosivity study performed during the pre-design survey. Regardless of the system selected, all ferrous piping systems must have the following:

- Longitudinal electrical continuity via the installation of joint bonds or fully welded joints
- Electrical isolation from buried and above grade metallic structures and grounding systems
- Two-wire corrosion test stations
- A protective coating and lining

Where corrosive environments are determined to exist, the application of cathodic protection is required. The application of cathodic protection is always required on buried or submerged, dielectrically coated steel and ductile iron. Cathodic protection systems can be either galvanic anode or impressed current.

6.4.1 **Electrical Continuity**

Electrical continuity is required for all metallic or reinforced cylinder pipes for corrosion monitoring and cathodic protection. Electrical continuity is achieved by the installation of bond cables or bonding clips across all non-welded joints. Bond cables and clips shall be of the appropriate size and number, depending on pipeline diameter.

6.4.2 **Electrical Isolation**

The electrical isolation of new piping systems is essential to proper corrosion control design. Electrical isolation is necessary to minimize cathodic protection current requirements and to avoid dissimilar metals couples and galvanic corrosion. New piping systems should be electrically isolated from existing piping systems, steel casings, concrete encased reinforcing steel, pipe supports, electrical grounding systems, motor operated valves, and any other structure that could adversely affect the performance of a cathodic protection system.

6.4.3 **Test Stations**

Two-wire test stations are required at a maximum of 1,000-foot spacing intervals for all pipes, and at sewer pump stations, as warranted, so that pipe-to-soil potentials can be monitored. Test stations are also required at the beginning and terminus of all pipelines. Specialty test stations such as 4-wire insulating flange test stations, 4-wire casing test stations, 4-wire IR drop test

stations, and foreign pipeline crossings should be utilized as required. The use of corrosion rate monitoring, electrical resistance probes should be considered at critical locations along pipeline alignments. These probes may be used on pipelines with or without cathodic protection or underneath polyethylene encased ductile iron pipe.

6.5 COATINGS AND LININGS

In selecting materials for use in a sewer environment, two main factors must be considered. The materials must be capable of performing the desired function in a safe and economical manner. Also, the materials must operate satisfactorily over the design life of the facility. As corrosion-caused deterioration of materials is a likely mode of failure, it is important to select materials which are capable of withstanding the aggressive environment to which they are exposed.

Coatings and linings used for sewer facilities must be resistant to moisture including possible splash zone exposure (intermittent exposure to air and moisture), atmospheric sulfides, sunlight, and atmospheric chlorides.

The DESIGN ENGINEER must properly specify manufacturer's recommendations regarding surface preparation prior to coating or lining application. A quality coating is of little benefit if it does not adhere to the surface to be protected. See Tables 6-2 and 6-3 for a summary guide of coatings and linings.

6.6 CATHODIC PROTECTION

Design of cathodic protection systems, both impressed current and galvanic (sacrificial anodes), is dependent upon the specific structural and environmental considerations of each project and should be performed by qualified individuals. Design life of systems is typically 20 to 25 years or may be required to be equivalent to the design life of the structure.

For either type of installation, monitoring of the installed system is essential to ensure continued proper operation of the system, throughout its life. Monitoring locations shall be selected to provide a level of confidence that the entire structure is being adequately protected and that the sites are accessible for future data collection.

6.7 SEWER PUMP STATIONS AND FORCE MAINS

6.7.1 Sewer Pump Station Piping Coatings

All coatings for sewer pump station piping shall be applied in accordance with the manufacturer's recommendations to ensure the following: proper preparation of surfaces to be coated typically requires SSPC-SP-10 sandblast to "white metal", proper prime coat, recommended coating thickness per coat, required drying times between coats, and required air temperatures and humidity limits. Provide at least two coats to achieve required final dry coating thickness. Coatings shall be applied pinhole free.

Table 6-6 summarizes the allowable coatings for pump station applications.

TABLE 6-6

ACCEPTABLE COATINGS/LININGS FOR SEWER PUMP STATION PIPING

Lining and Coating Material	Acceptable Applications				Notes
	Wet Well Piping		Dry Well Piping		
	Interior Lining	Exterior Coating	Interior Lining	Exterior Coating	
Fusion-Bonded Epoxy	X	X	X	X	
High-Density Epoxy (100% solids)	X	X	X	X	a, b
Polyethylene	X	–	X	–	–
Polyurethane	–	X	–	–	–
Enamel	–	–	–	X	–

Notes:

- a. Minimum dry thickness of coating is 12 mils, applied pin-hole free in two coats.
- b. Only allowable for fittings/valves where fusion-bonded epoxy cannot be used.

6.7.2 Force Main Linings and Coatings

Allowable corrosion protective coatings and linings are given in Table 6-7.

TABLE 6-7**FORCE MAIN CORROSION PROTECTIVE COATINGS AND LININGS**

Lining and Coating Material	Force Main Piping Interior	Force Main Piping Exterior	Comments
Fusion-Bonded Epoxy	X	X	b
High-Density Epoxy (100% Solids)	X	X	a, b, c
Fusion Polyethylene	X	–	b
Coal Tar Epoxy	–	X	b, d
Wax Tape Wrap	–	X	b

Comments:

- a. Epoxy 12 mil minimum dry film thickness
- b. Only allowable for fittings/valves where fusion-bonded epoxy cannot be used
- c. Coal tar 20 mils minimum dry film thickness

6.7.3 Valve Coatings

All valves located in the dry well, wet well, or buried service shall be coated with fusion-bonded epoxy coating (3M "Scotchkote" #134 or equivalent) inside and out with a 12 mil. minimum thickness. Where fusion-bonded epoxy cannot be applied, high-density liquid epoxy (3M, Inc. #312 or equivalent) shall be allowed (note in project specifications).

6.7.4 Pump Interior Lining

Coat the pump bowl and casing, inside and out, and the suction can interiors with 3M Inc. #134 "Scotchkote" fusion-bonded epoxy or approved equivalent. Final dry coating thickness is to be a minimum of 8 mils.

6.7.5 Wet Well & Emergency Storage Tank Lining

The interior ceiling and walls of wet wells and emergency storage tanks shall have cast-in-place T-Lock PVC liner. Wet well and emergency storage tank floors shall be coated with 100 mils of polyurethane over an epoxy primer base in accordance with SSPWC, Section 500-2.4.

CHAPTER 7 SEWER PUMP STATION DESIGN CRITERIA AND EQUIPMENT DESIGN GUIDELINES

SECTION 7.1 GENERAL REQUIREMENTS FOR DESIGN ENGINEERS

7.1.1.1 **Implementation of Design Guide Requirements:** This Chapter describes the basic flow capacity, hydraulic design, and equipment/material requirements for new City sewer pump station facilities. The DESIGN ENGINEER is required to comprehensively implement the criteria in this Chapter in the preparation of detailed design drawings and specifications.

7.1.1.2 **Energy Efficient Designs:** Pump stations shall be designed for energy efficiency including, but not limited to, the design of force mains, pump selection, overall head losses, lighting, ventilation and odor control. Pumps shall be designed and specified to operate within the manufacturer's recommended operating range and should be within 10-15% of their respective best efficiency operating point. Pumps shall be sized for short-term as well as for long-term growth potential. The design shall be coordinated with San Diego Gas and Electric (SDG&E) Company and their contracted agencies to optimize the use of the available energy-saving incentives and grants.

Occupied facilities shall be designed and oriented to take advantage of natural ventilation, solar gain/protection and pavement shading with deciduous trees when feasible.

Those projects that require energy will be reviewed by the Energy Section of Engineering and Program Management Division, Public Utilities Department.

7.1.1.3 **Documentation of Implementation of Design Guide Requirements:** The DESIGN ENGINEER shall prepare a written response indicating that the design complies with the required criteria. This can be in the form of a cover letter attached to a copy of the criteria with a "check-off" on each item incorporated into the design of the station. The DESIGN ENGINEER shall also reference and discuss any criteria in this listing to which the DESIGN ENGINEER takes exception. The DESIGN ENGINEER shall note when each particular criterion will be incorporated into the design (i.e., at which stage of design submittal). The "check-off" list shall also have space in the margin to note where in the plans and specifications a criterion has been incorporated. This response shall be updated and resubmitted with each design submittal.

7.1.1.4 **Written Responses to Design Review Comments:** The DESIGN ENGINEER shall receive design review comments for all design phases from the City as tabulated written comments in the format below. For all

comments, the consultant shall provide written response comments in a tabular form including the following information: comment number, applicable drawing and/or specification reference, review comment summary, City recommended action, and DESIGN ENGINEER responses, including status of changes (Ref. TABLE 7-1). A similar procedure is in place relating to major facilities in the Clean Water Program Guidelines. This should serve as a guide for the DESIGN ENGINEER to prepare responses to the City’s review comments.

TABLE 7.1-1

DESIGN REVIEW COMMENTS FORM

Comment No.	Reference	Comment	Action	Responses

- 7.1.1.5 **“Special Station Requirements”**: The design criteria for special station requirements are optional and are not required for all stations. The City, in consultation with community representatives and regulatory agencies, will determine the special station requirements of the project. Special stations are typically those with high lift conditions, high pumping capacity requirements, or a wide range of variations in pumping capacity required, i.e., variations between minimum dry weather flow (Ref. Subsection 7.2.6.4) and peak wet weather flow. It may also involve special environmental concerns or other special design requirements. Special station requirements shall be identified in the scope of work and any deviations will require approval by the Senior Engineer of Wastewater Collections Division, Public Utilities Department.

- 7.1.1.6 **Project Meetings with the City**: Prior to the commencement of design, the DESIGN ENGINEER shall meet with the City to review project scope, schedule, submittal requirements, lines of communication, invoicing procedures, etc. Project review meetings shall be held following each design submittal to discuss how City comments are being addressed. The DESIGN ENGINEER’s responses to City comments shall be submitted to the City a minimum of one week prior to the project review meeting. Additional project meetings may be held to discuss key design information, Special Station Requirements compliance, and design progress review. The DESIGN ENGINEER shall prepare meeting notes summarizing all issues discussed and their resolutions.

- 7.1.1.7 **Requirements for Design Documents**: The design drawings and technical specifications shall include all information necessary for the construction of the pump station per normally accepted requirements of engineering design practice. Design drawings shall include, but not be limited to, pump curves,

equipment schedules, design details, pipeline profiles, civil plans (site, grading, yard piping), high-line piping installations for temporary bypass pumping, architectural plans (elevations, schedules), location of equipment to be installed and clearances, existing underground utilities, construction salvage and demolition drawings and notes, structural and mechanical plans and sections, heating, ventilation, and air conditioning (HVAC) and plumbing diagrams, electrical layouts, electrical power and lighting diagrams, control system layouts and schematics, piping and instrumentation diagrams, warning notes, complete dimensions of all aspects of station construction (Contractor shall not be required to scale any dimensions from the drawings), traffic control plans, and landscaping plans. Construction phasing drawings, notes and schedules shall be included as necessary to define and detail temporary equipment and facilities necessary for the continuous operation of the facilities undergoing rehabilitation or replacement. The DESIGN ENGINEER shall provide notes that the Contractor shall be responsible for job site safety.

- 7.1.1.8 **Private Sewer Pump Stations:** For private pump stations requirements, refer to Chapter 1, Subsection 1.5.2.

**SECTION 7.2 SUMMARY OF FACILITY CAPACITY AND
HYDRAULIC DESIGN CRITERIA****7.2.1 PURPOSE**

This Section provides the basic criteria for determining the required facility capacity and hydraulic design requirements of the pump station facility. The DESIGN ENGINEER shall also be responsible for determining the required capacity and design of other facility subsystems not addressed here per normally accepted design practice.

7.2.2 DESIGN CAPACITY CALCULATIONS

7.2.2.1 Pump Station Design Capacity Calculation: Sewer pump station pumping capacity shall be calculated as described in Chapter 1, Subsection 1.5.1.

7.2.3 PUMP AND SYSTEM CALCULATIONS

7.2.3.1 Constant versus Variable Speed Pumps: Constant speed pumps shall be used where pump station design capacity is less than 3 million gallons per day (mgd) or 2000 gallons per minute (gpm). Variable speed pumps shall be evaluated for use where pump station design capacity is greater than 3 mgd capacity and as directed by the Senior Civil Engineer. Where pump station capacity is 1.5 mgd to 3 mgd, the facility shall similarly be evaluated for variable speed if required by special site conditions and/or inflow conditions.

7.2.3.2 Variable Speed Pumps: (Special Station Requirement): Variable speed pumps may be used for pump stations greater than 3 mgd capacity (see above for stations with 1.5 to 3 mgd capacity) as approved by the Senior Civil Engineer. In the preliminary design report for the facility, the DESIGN ENGINEER shall prepare an alternative analysis that calculates the pumping operation/cycling of constant speed versus variable speed pumps to determine if variable speed is the best apparent alternative for the facility. This shall include an evaluation of operation/cycling that will occur during periods of minimum inflow rate vs. periods of maximum inflow rate. The relative life-cycle cost comparison of constant versus variable speed pumps for pumping stations shall include the cost of all structure(s), mechanical and electrical equipment that would be affected by the pump selection. The City shall thereafter direct the DESIGN ENGINEER to incorporate constant or variable speed pumps in its design.

7.2.3.3 Uniform Sizing and Number of Service and Standby Pumps: All installed pumps shall generally be of the same size. The minimum number of pumps

per station shall be two. In stations with two pumps, each pump shall be capable of pumping the design flow with the second pump acting as a full standby. In stations with more than two pumps, an identical “standby pump” of the same size and capacity as the other service pumps shall be installed.

7.2.3.4 **Calculation of Hydraulic Losses:** Procedures to be used for calculating dynamic losses shall follow those presented in the most current edition of “*Pumping Station Design*” by Garr M. Jones, et al; Butterworths-Heinemann Publishers.

7.2.3.5 **Allowable Pipe Velocities:** In general, the maximum recommended suction pipe velocity is 5 fps. Velocity at the suction bell shall not exceed 3.5 fps. Install a larger suction line than the pump inlet diameter if required to reduce velocity and inlet head losses, in order to provide the required net positive suction head (NPSH) according to the Hydraulic Institute, and prevent cavitations for high flow rate pumps.

The maximum recommended velocity in the station discharge piping is 8 fps.

Refer to Section 7.9 for allowable force main velocities.

Suction and discharge pipe design shall follow Hydraulic Institute recommendations for items not addressed in this Section.

7.2.3.6 **NPSHA Calculation:** Net positive suction head available (NPSHA) shall be calculated for all pumps other than column pumps. NPSHA shall be calculated on the basis of the static suction head in feet of water (pool elevation) in the wet well, minus the elevation of the center of the pump, plus the absolute barometric pressure (in feet) minus the vapor pressure of water (in feet) at 85 deg. F at sea level, minus the calculated losses from the wet well to the pump connection. Pump specifications shall include NPSHA values for all anticipated operating conditions. NPSHA shall always be more than net positive suction head required (NPSHR) by the selected pump(s).

NPSHR shall mean the NPSHR determined in accordance with ANSI/HI 1.6 or 2.6, as applicable for the proposed pump. The DESIGN ENGINEER shall require the Contractor to document the method used to determine NPSHR for the proposed pump in its pump submittal material.

The pump station design and pump selections shall be made such that NPSHA is equal to or exceeds the greater of: NPSHR plus 5.0 feet or 1.35 times NPSHR.

7.2.3.7 **Pump and System Curves:** Calculations and curves shall be developed for each station, as described in the following paragraphs.

- 7.2.3.7.1 **Calculation of System Curves:** Station system curves shall include static lift and all dynamic losses from the station suction piping to the point of discharge. Dynamic losses and plotted system curves (total dynamic head) shall be calculated on the basis of Hazen and Williams C values of 110, 130 and 140.
- 7.2.3.7.2 **Selection of Candidate Manufacturer's Pump Curves:** For each of the above calculated C values, select a pump curve from a manufacturers' catalogue that meets the required design operating point(s). Each pump curve shall be accomplished by the same model pump, with only the diameter of the impeller varying (note: refer to comments below on purpose of pump curve plots).
- 7.2.3.7.3 **"Flat" Pump Curves:** Avoid pumps with "flat" pump curves where a small change in total dynamic head (TDH) will result in a large change in pump flow.
- 7.2.3.7.4 **Plotted System and Pump Curve Information on Design Drawings:** For each of the C value condition, provide a plot of the calculated system curve and the associated selected pump curve.
- 7.2.3.7.5 **Multiple Pump Operation Curves:** Where multiple pump operation is designed (i.e. multiple pumps will operate in series or parallel), provide combined pump curves for multiple pump operation required to meet pumping capacity requirements. Should variable speed pumps be selected, pump curve plots over the full range of variable speed pumping, and for multiple variable speed pumps in operation shall be provided.
- 7.2.3.7.6 **Other Information and Pump Curves:** The plots of the associated system and candidate manufacturers' pump curves required as design submittals under Section 7.2.3.7 shall include the following information: Head versus Q, NPSHR versus Q, Hp versus Q, and efficiency versus Q for the candidate pumps at the required operating speed(s). These curves also shall have the manufacturers' allowable operating regions (ANSI/HI 9.6.3) plotted on them to demonstrate that all specified continuous duty operating points are within the candidate manufacturers' recommended pump operating regions. The selected motor shall be non-overloading throughout the maximum speed curves. The DESIGN ENGINEER shall require the Contractor to submit the information described above and to demonstrate that his proposed pumps meet the same requirements and those described below.
- 7.2.3.7.7 **Pump Selection:** The selected pump must provide for stable operation at all operating points falling between the boundary conditions established by the worst (i.e., greatest static lift and lowest pipeline C value) and best (i.e., least static lift and highest pipeline C value) set of assumptions used for development of the station system curves. These boundary conditions must be

within the limits of the pump manufacturers' allowable operating region (ANSI/HI 9.6.3). The selected pump must also meet the criteria of Subsection 7.1.1.2 - Energy Efficient Designs.

The selected pumps shall operate without damaging cavitation or vibration over the entire design range of flow and head conditions (operating points) including those produced by multiple pump operation and/or variable speed.

Pump NPSHR shall be checked against the NPSHA to assure the pump design requirements of subsection 7.2.3.6 are met.

Unless otherwise noted or specified, pump Head/Q curves shall slope in one continuous curve within the specified operating conditions. No points of reverse slope inflection capable of causing unstable operation will be permitted within the specified zone of continuous duty operation. Pumps with Head/Q curves as described in paragraph 9.6.3.3.12 of ANSI/HI 9.6.3 are specifically prohibited if these characteristics will cause unstable operation within the specified range of operating conditions and where startup/shutdown conditions entail operation against a slow opening/closing valve.

Pumps shall be designed in accordance with applicable portions of ANSI/HI 1.1-1.6, 2.1-2.6, and 9.1-9.6. The pumps shall be specifically designed to pump raw wastewater and shall operate without clogging or fouling caused by material in the pumped fluid at any operating condition within the range of service specified.

7.2.3.7.8 Design Pump Rating and Requirements: The specified pump shall be rated to deliver the station design capacity at the worst combination of static head and pipeline C value, and also selected to operate in the manufacturers' Preferred Operating Region (ANSI/HI 9.6.3) at the Head/Q curve intersection with the system curve established by the best combination of static lift and pipeline C value.

The rated condition and all other continuous duty operating conditions specified for full speed operation in the detailed specification section shall fall within the manufacturers' Preferred Operating Region as defined in ANSI/HI 9.6.3. The Preferred Operating Region shall be not less than that specified in paragraph 2.1.12 of API 610. Proposed pumps shall be selected to allow not less than a five percent increase in head, as specified in paragraph 2.1.4 of API 610. Variable speed operation to achieve this objective shall not be considered. Pump selections proposing impeller diameter greater than 90% of the maximum size for the proposed pump model and casing size shall not be accepted.

7.2.3.7.9 Impeller Information for Plotted System and Pump Curves: The purpose of providing separate plotting of the above associated system and pump

curves on the design drawings is to show that for the above various C values, the candidate manufacturers' pump can be made to operate at the required design points. This will be accomplished by only varying (replacing) the impeller diameter. This is to assure that the pump station pumps can be configured and designed to operate through the "C" value changes that typically occur during the extended service of the facility (i.e., grease coating and corrosion occurring inside the pipe reducing the C factor value over the service life).

- 7.2.3.7.10 **Specification of Design Pumps:** Based on the above calculations, the candidate manufacturers' design pump to be listed in the project specifications and supplied during construction shall be specified so the installed impeller shall be the correct size to operate with the C = 130 curve. In no case, shall the maximum impeller diameter available for a particular model pump be selected (Ref. Subsection 7.2.3.7.8).

7.2.4 **MASS ELASTIC SYSTEMS AND CRITICAL SPEED CALCULATIONS**

Each pumping unit, consisting of pump, intermediate shafting, couplings, motor, supports and all attached appurtenances shall have no dangerous critical or resonant frequencies or multiples of resonant frequencies within 20 percent above and 15 percent below the speed (range) required by the pump to meet the indicated operating conditions. A dangerous critical speed shall be defined as one which produces a torsional stress exceeding 3500 psi. The DESIGN ENGINEER shall require the pump manufacturer, through the Contractor, to be responsible for the analysis of critical speeds and the complete mass elastic system, which shall be analyzed and certified by a registered professional engineer regularly engaged in this type of work. Analysis shall be at least equal to the industry standard technique developed by Dunkerly and Holzer.

7.2.5 **SURGE PRESSURE CALCULATIONS**

- 7.2.5.1 **Surge Analysis Methodology:** All pumping stations shall be independently evaluated by the DESIGN ENGINEER for the potential for hydraulic transients. Computer programs for transient analysis shall be approved by the City on a case-by-case basis. Current state-of-the-art computer programs for transient analysis, such as LIQT developed by Stoner Associates, Inc., or SURGE 5 developed by the University of Kentucky, or NETWORK-SURGE developed by John List, or other programs approved by the City, shall be used for evaluation of all transient phenomena and proposed control measures.

Each program is unique in terms of its capabilities and must be assessed in each situation to make sure the program can handle the complexities of the analysis involved.

- 7.2.5.2 **Submittal of Hydraulic Transient Memorandum:** Prior to initiating detailed design of a pumping station, the DESIGN ENGINEER shall submit to the City a Hydraulic Transient Memorandum describing and summarizing the transient analyses performed including assumptions made, analysis program input and output tables, graphs, figures etc. as necessary. The memorandum shall also contain a narrative description of any potential for hydraulic transients and the steps recommended by the DESIGN ENGINEER for further action or mitigation of the hydraulic transients. Based on the contents of this submittal, the City may direct the DESIGN ENGINEER to design the necessary means for mitigation of hydraulic transients. The memorandum shall be signed and sealed by a registered professional engineer.
- 7.2.5.3 **Transient Control Measures:** Devices for transient control shall be considered in design, and installed as required to reduce pressure surges with pump starts and stops. Transient control measures to be considered singly or in combination for wastewater systems are limited to the following and listed in the order of preference:
- 7.2.5.3.1 **Shaft-Mounted Flywheels:** to increase moment of inertia for systems subject to column separation.
- 7.2.5.3.2 **Force Main Alignment:** revisions to eliminate potential column separation zones.
- 7.2.5.3.3 **Vacuum Relief Valves and Pressure Release Valves (Combination Type):** Locate at critical locations along the force main to prevent column separation and damaging vacuum conditions following pump shutoff.
- 7.2.5.3.4 **Slow-Closing, Hydraulically-Operated Pump Discharge Valves:** to control head rise in the pressurized discharge pipelines.
- 7.2.5.3.5 **Vacuum Relief Valves or Check Valves (Vented from Wet Well):** for entry of air into the line to prevent column separation following pump shutoff.
- 7.2.5.3.6 **Non-Approved Measures:** Surge tanks are specifically prohibited as water hammer control measures for wastewater pumping systems.

7.2.6 WET WELL CALCULATIONS

7.2.6.1 **Flow Data Table:** Provide a table of flow data on the design drawings for the sewer line discharging into the wet well up to 500 feet upstream, as shown in Table 7.2-1:

TABLE 7.2-1

FLOW DATA

Pipe Section (MH# to MH#)	Peak Q	"N"	d/D

7.2.6.2 **Wet Well Inlet:** The wet well inlet sewer invert shall be above the normal high water operating level. The wet well inlet sewer shall be designed to minimize turbulence and odor generation, with no free fall discharge into the wet well under any operating condition. In addition, the influent pipe shall not discharge directly on top of the suction elbow of a pump. The wet well inlet shall be designed in accordance with *ANSI/HI 9.8 Pump Intake Design Standard for Solid-Bearing Liquids*.

7.2.6.3 **Wet Well Operating Volume:** The wet well operating volume and pump(s) sequencing start/stop call levels shall be configured to meet minimum inflow conditions through peak wet weather inflow conditions. The total wet well operating volume is the volume between the first pump on start level in the wet well to the all pumps on stop level. For periods of very low inflow, the volume to be pumped by the first pump call shall be as small as possible to allow regular pumping down of the wet well volume to prevent septic action from taking place. However, the wet well must be large enough to provide at least 5 minutes pump running time at minimum flow to prevent overheating of the electric motor and controls (refer to minimum operating volume calculation in Subsection 7.2.6.5).

Where variable speed pumps are installed (i.e. to provide the required variation in pumping rate for minimum inflow through peak wet weather inflow conditions), the pump(s) start/stop call levels in the wet well shall be configured to satisfy the above requirements over the entire range of design pumping rates and pump sequencing.

7.2.6.4 **Minimum Inflow Calculation:** In the sizing of a pump station wet well, determination of minimum flow is also important to control cycling of constant speed pumps. Wet wells should be large enough to provide at least 5 minutes of pump running time to prevent overheating of the motor, but not too

large in order to prevent septic conditions in the wet well. Table 7.2-2 shall be used to determine minimum flow (note: typically 20% to 30% of the average daily flow dependent on population and flow (Source: WPCF Manual of Practice No. 9). No reference to Table 7.2-2

TABLE 7.2-2

RATIO OF MINIMUM TO AVERAGE FLOW

Average Flow (mgd)	Minimum Flow Factor
Less than 1	0.2
2	0.24
3	0.26
4	0.27
5	0.28
7	0.30
10	0.32

7.2.6.5 First Pump Call Level in the Wet Well Operating Volume: The minimum wet well operating volume (i.e. first pump call operating volume based on start and stop levels) shall be equal to the following (Ref. Subsection 1.3.2.2):

$$\text{First Pump Call Wet Well Operating Volume} = [(\text{Pump Station Design Capacity}) - (Q_{\text{Minimum Inflow}})] \times 5 \text{ Minutes}$$

Where:

$$Q_{\text{Minimum Inflow}} = (\text{Average Dry Weather Flow}) \times (\text{Minimum Flow Factor, per Table 7.2-2})$$

7.2.6.6 Wet Well Operating and Alarm Levels: The wet well low and high operating water levels and alarm levels shall be indicated on the design drawings. The pump automatic shut-off level shall be located above the pump volute level to ensure sufficient net positive suction head per Section 7.2.3.6. Minimum submergence of the pump suction bells (this defines the low flow level) shall be not less than that determined in accordance with Section 9.8.7 of the *Hydraulic Institute Pump Intake Design Standard*. The automatic low level shut-off feature shall be inoperable during cleaning cycles of self-cleaning trench type wet wells.

7.2.6.7 **Emergency Storage Volume:** Separate from the wet well operating volume, the DESIGN ENGINEER shall provide an emergency storage volume sufficient to accommodate storage of a two-hour inflow at peak wet weather flow. The total pump station sewage storage volume (i.e., volume of the wet well above the station HIGH WATER ALARM to the lowest sewage spill point) can be accomplished by the following measures singly or in combination, and listed in order of preference: additional storage in the wet well above the operating volume, separate overflow tank and storage in the inlet line to the spill level.

This "emergency repair holding time" will allow operating personnel at least two (2) hours to respond to a station failure alarm and/or to shut off all pumps to perform emergency repairs to correct a failure condition. In addition, this storage is also available to be utilized for flow equalization during large storm events should peak wet weather inflow exceed the pump station design capacity.

7.2.6.8 **Influent Line Storage:** The wet well influent sewer shall not be designed to accommodate storage except as required for "emergency repair holding time" as described in Section 7.2.6.7 (note: this causes grease buildup problems in the inlet line). This storage shall be utilized where it is not practical to provide two-hour emergency storage in the wet well and/or a separate overflow storage tank.

7.2.6.9 **Spill Location Indication:** Influent sewer and pump station spill locations shall be indicated on the design drawings (lowest upstream elevation or wet well cover elevation where backup spill will occur). Mean sea level (MSL) elevation shall be included for information for spill location.

7.2.7 **SIX-HOUR EMERGENCY STORAGE (SPECIAL STATION REQUIREMENT)**

7.2.7.1 **Closed Tanks:** In areas where protection from spillage must be provided, the size of the pump station emergency storage capacity will be determined by the Wastewater Collection Senior Civil Engineer. For example, in areas where maximum protection from a sewer spill would enter a potable water supply reservoir, six-hour emergency overflow storage (at peak wet weather inflow rate) shall be required. This storage requirement is in addition to the wet well operational storage. The emergency storage can be an underground structure or a separate tank that is normally empty but can drain by gravity back into the wet well.

In environmentally sensitive or public contact areas such as at a beach, the Wastewater Collection Senior Civil Engineer shall determine the size of the emergency storage capacity.

Similar to section 7.2.6.7 above, this storage is also available to be utilized for flow equalization during large storm events should peak wet weather inflows exceed the pump station design capacity.

7.2.7.2 **Ponds:** In isolated areas, an open-air basin or a pond may be provided as an emergency storage in lieu of an underground concrete structure. However, the basin shall be lined with an impermeable flexible barrier protected by a layer of concrete. Provisions shall be made for draining the emergency storage basin back into the wet well.

7.2.8 **FORCE MAIN**

7.2.8.1 **Capacity of Discharge Sewer:** During pump station design, the DESIGN ENGINEER shall verify that there is sufficient capacity to handle the increased sewer flow in the gravity sewer into which the force main discharges (Ref. Chapter 1, Subsection 1.7.2 for additional information).

7.2.8.2 **Maximum Force Main Retention Time:** The following calculations shall be used to determine maximum retention time within the force main. This information shall be utilized with other hydraulic factors (i.e. maximum wet well detention time, downstream gravity sewer discharge conditions) to determine if chemical addition for odor control is required.

$$\text{Force Main Volume} = \text{Length} \times \text{Area}$$

$$\text{Minimum Pump Run Time (PRT)} = 5 \text{ Minutes} = \frac{\text{First Pump Call Wet Well Operating Volume}}{[(\text{Pump Station Design Capacity}) - (Q_{\text{minimum inflow}})]}$$

$$\text{Number of Cycles} = \frac{\text{Force Main Volume}}{[(\text{Pump Station Design Capacity}) \times \text{PRT}]}$$

$$\text{Maximum Wet Well Filling Time} = \frac{\text{First Pump Call Wet Well Volume}}{(Q_{\text{minimum inflow}})}$$

$$1 \text{ Cycle Period} = \text{Maximum Wet Well Filling Time} + \text{PRT}$$

$$\text{Maximum Retention Time} = (\text{Number of Cycles}) \times (1 \text{ Cycle Period})$$

SECTION 7.3 PUMPS**7.3.1 VERTICAL NON-CLOG PUMPS**

7.3.1.1 **Standard Design:** Vertical non-clog pumps driven by extended drive shafts are the standard type of pump to be provided in sewer pump stations, and shall have the following features.

7.3.1.2 **General Construction:** Pumps shall have grey iron impeller; stainless steel wear ring on the pump volute and on the impeller; a Type 304 stainless steel shaft and Type 400 shaft sleeve; mechanical seals (refer below); powder epoxy coat on impeller, interior of bowl and water passages; and Type 316 stainless steel fasteners securing the impeller and in all wetted areas and casing bolts. Pumps shall have volute and suction inlet hand holes/inspection plates. Provide a 2-inch valved and capped drain connection on the pump suction elbow.

7.3.1.3 **Maximum Size Solid Passing through Impeller:** All pumps shall be sized to pass a 3-inches spherical solid.

7.3.1.4 **Mechanical Seals:** Pumps shall have a single cartridge type mechanical seal cooled by product water routed from the backhead area into the stuffing box through a machined clearance. Pump/impeller shall be designed to provide positive pressure above atmospheric to the stuffing box area to allow seal flush line to function. Stationary portion of the seals shall have stainless steel construction. Rotating faces of the seal shall be of silicon carbide against carbon. Seal shall be manufactured by AES Engineering - C.U.R.C. Type, or Chesterton 155, no exceptions (note: this mechanical seal specified is a standard single cartridge type with standardized dimensions). The seals shall be constructed to allow rebuilding of the seal utilizing repair parts.

7.3.1.5 **Pump Pressure Gauge Installation:** Provide a combination vacuum and pressure gauge on the suction side between the pump and the suction isolation valve and a pressure gauge on the discharge side of each pump between the pump and the discharge check valve. Gauge assemblies shall include the following and mount off of the piping to reduce vibration: Type 316 stainless steel nipple into piping; 1-inch stainless steel isolation ball valve; high-pressure rated flexible hose; 1-inch stainless steel ball valve; air release fitting; diaphragm seal and pulsation dampener; pressure gauge with safety blow-out relief (diaphragm seal and gauge filled with glycerin for isolating valve from sewage).

7.3.1.6 **Pump Bases:** Pump concrete support bases shall be monolithically constructed with the dry well floor concrete pour. Edges of the pump concrete bases shall be chamfered (1 inch minimum).

7.3.1.7 **Stainless Steel Anchor Bolts for Pump Bases:** Anchor bolts shall be cast in place only, and constructed with Type 316 stainless steel. Wedge type or chemical type anchor bolts are not allowed for rotating equipment, and shall be specifically prohibited.

7.3.1.8 **Pump Drain Lines:** Provide 2-inch maintenance drain line on the suction elbow of each pump. Materials shall be Type 316 stainless steel and include a stainless steel ball valve and end with a quick cam type coupling. Provide a flexible hose to be stored in the station that will connect to the coupling, and be used to drain to the sump.

7.3.2 **MOTORS**

7.3.2.1 **Motors for Extended Shaft Pumps:** The motors specified in this subsection are the standard type to be provided in sewer pump stations, and shall have the following features.

7.3.2.2 **Motor Horsepower Selection:** The motor shall be sized with sufficient rated name plate horsepower to meet the requirements of Subsections 7.2.3.7.9 and 7.2.3.7.10. Provide design pumping capacity at varying "C" friction values that may occur over the service life of the force main.

7.3.2.3 **Motor Features:** Specify totally enclosed fan cooled (TEFC) motors to resist water penetration. Motors shall be of a high efficiency type. Specify resistance strip type motor heaters with automatic disconnect upon motor start to reduce corrosion and a manual on/off breaker switch. Motor windings are to be all copper and epoxy encapsulated (aluminum windings or components are not acceptable). Motor controls are to include high-temperature safety switches installed in the motors. Motors shall be rated for a minimum of ten starts per hour and NEMA motor design letter shall be "B". Starting code letter/locked rotor KVA/hp rating shall be "F" or better. Motor winding insulation shall be epoxy and have a class "F" rating. The motor temperature shall not exceed class "B" temperature limits as measured by resistance method when the motor is operated at full load at 1.15 safety factor continuous in a maximum ambient temperature of 50°C. Motors shall have a Factory Mutual approval. Motor nameplate horsepower must exceed maximum required by pump under all possible operating conditions. Bearing temperature rise at rated load shall not exceed 60°C. For efficiency, the motors specified for constant speed applications shall be rated premium efficiency. Minimum guaranteed motor efficiencies shall be per Specification Section 16040 of the Clean Water Program Guidelines. Avoid greatly oversizing motors since both efficiency and power factors drop in motors running below their full load rating. Specify a 1.15 service factor (SF) for constant speed motors and 1.2 service factor for variable speed motors.

Provide a motor stand as required to allow access to the motor coupling for maintenance. Motors controlled by variable frequency drive (VFD) shall be rated for the service.

- 7.3.2.4 **Soft Start Motor Starters:** All motors shall have programmable solid state “soft start” starters, Allen Bradley “SMC” or approved equal. Provide by-pass magnetic contactor, which shall be used for by-passing the solid state starter when full speed is reached in order to extend the life of the solid state starters, or for emergency across the line starting in the event of soft start failure.

7.3.3 EXTENDED DRIVE SHAFTS

- 7.3.3.1 **General:** Drive shafts shall be fitted with universal joints (U-joints) to assist in disassembly or removal from the station. Shaft length typically shall not exceed 10 feet. Intermediate motor installations shall be located above two-hour overflow storage level. Generally, based on typical manufacturer recommendations, the intermediate shaft shall be furnished as a single unit with couplings and shaft offset between ½ and 1½ degrees.

- 7.3.3.2 **U-Joint Greasing Access:** Motor support bases (including installations with inertial flywheels) shall have sufficient height and clearances above the floor to allow ease of access to U-joints for greasing. At intermediate levels, provide catwalks (with safety ladders) for ease of access to the U-joints for maintenance. Drive shaft safety guard shall have secured access doors for this purpose.

- 7.3.3.3 **Safety Guard:** Install a safety guard around the entire length of the drive shaft with latched access doors at the U-joints. The guard shall be designed with sufficient strength to enclose a swinging, broken, rotating drive shaft. The guard shall be installed in sections to allow removal of the pump after removal of the lower shaft guard section.

- 7.3.3.4 **Intermediate Level Motors (Special Station Requirement):** In stations requiring long drive shafts (30 ft and longer), the motors shall be installed at an intermediate floor level to reduce the drive shaft length. This intermediate floor level shall be above the wet well emergency overflow level.

7.3.4 EQUIPMENT CLEARANCES

- 7.3.4.1 **Minimum Equipment Clearances:** Minimum equipment clearance shall be as follows:

Between adjacent items of equipment (pumps, motors, piping, equipment, appurtenances, and station walls: 3' 6" or manufacturer's recommended minimum maintenance clearances plus 1' 0", whichever is more stringent.

Vertical (floor to overhead obstruction): 7' 6"

Clearance shall be actual, to most outstanding dimension (i.e., edge of flange), not nominal. Equipment shall be located to provide the above clearances on at least three sides.

7.3.5 **SPARE PARTS TO BE FURNISHED**

For installations with two (2) or more installed pumps, furnish the following spare parts and spares:

- a. Provide a complete spare pump to be stockpiled. The spare pump shall be complete and ready for installation and shall include all parts except the pump stand.
- b. Provide a complete set of mechanical seals, bearings, gasket set, wear rings, fasteners, and spare impeller for each of the service, standby and spare pumps to be provided.

7.3.6 **LARGE PUMP STATIONS (SPECIAL STATION REQUIREMENT)**

7.3.6.1 **Classification:** With special approval by the Senior Civil Engineer, the following may be required for large installations (capacity greater than 3 mgd):

7.3.6.2 **Mechanical Seals for Variable Speed Pumps (Special Station Requirement):** Seals on variable speed pumps shall be designed to operate properly over the range of pump speeds and shall meet the requirements of Subsection 7.3.1.4.

7.3.6.3 **Split Mechanical Seals (Special Station Requirement):** Where large pumps cannot be easily removed for replacement of seals, provide split seals for ease of replacement and ensure compliance with all the requirements of Subsection 7.3.1.4.

7.3.6.4 **Air-Gap Seal Water Pressurization System (Special Station Requirement):** Cooling mechanical seals with pressurized potable water fed from air-gap tanks requires special approval from the Senior Civil Engineer. At the seal water connection at each pump provide inlet/outlet isolation valves, head-loss gauge, and flow-rate gauge. The seal water shall have a constant pressure of 10 psi minimum above the operating pressure inside the

pump casing. The pump controls shall cause the pump to stop running upon loss of seal water. The tanks shall have a make-up water supply line.

7.3.6.5 **Air-Gap Tank Installation (Special Station Requirement):** The air-gap tanks and pumps shall be located at the station grade level. Provisions shall be made for periodic drainage of air-gap tanks to prevent scale buildup and contamination. Per Health Code requirements, the system requires reduced pressure backflow protection devices supplying the air-gap tanks located at grade level to allow operation of the system during maintenance and/or testing. All piping downstream of the air-gap tanks must be above ground and visible in the station to prevent the possibility of illegal connections. Provide two seal water regenerative turbine type pumps (one connecting to each tank) with automatic start of the second pump as backup if the on-line pump fails. Provide a precharged type diaphragm hydro-pneumatic tank on the common pump discharge line. A telemetry alarm shall indicate a loss of seal water pressure and shut down the pump on preset low pressure of the seal water. The system shall have 50 micron filters equipped with differential pressure gauges (to detect clogging of the filters) on the seal water return line to the air-gap tank.

7.3.7 **PUMP STATION EQUIPMENT RETROFIT PROJECTS (SPECIAL STATION REQUIREMENT)**

7.3.7.1 **Retrofitting Equipment in Existing Pump Stations:** The following types of equipment are not allowed for the design of new facilities due to higher maintenance requirements and other operational concerns. Where existing facilities with this type of equipment are retrofitted, the following equipment features shall be incorporated:

7.3.7.1.1 **Close-Coupled Motors (Special Station Requirement):** This type of installation is typically not allowed due to the potential of flooding damage in the pump room. Where this type of pump is required (i.e., application in retrofit projects), the following features shall be provided: utilize totally encapsulated motors capable of operation in submerged conditions and NEMA 6P submerged rated power and control wiring. Utility standard motor frame size dimensionality for ease of replacement with standard motors shall be required.

7.3.7.1.2 **Dry Pit Submersible Pump Installation (Special Station Requirement):** This type of pump is typically not allowed due to the higher maintenance requirements and higher equipment costs. Where this type of pump may be required (i.e. application in pump station retrofit projects, or coastal pump station flooding concerns), the following features shall be provided: moisture sensing probes (detect seal failure and send warning only, does not lock out pump); over-temperature detectors; positive oil circulating cooling of motor or

product water cooling of the motor; stainless steel motor and pump shafting; gray iron impeller; powder coat epoxy bowl and impeller; silicon carbide mechanical seals; bearing retaining rings on the shaft; stainless steel wear rings; and a volute hand hole access plate on the pump for cleaning. The pump motor shall be rated for a minimum of ten starts per hour and also for continuous running in a dry well installation without damage. The pump shall have class "F" rated insulation. The pump shall have a Factory Mutual, or UL explosion-proof rating. All power and control cables to the pump below the motor control center level shall be NEMA 6P rated so that the pumps will continue to run if the pump room is flooded. Cables shall be routed directly from the MCC level, supported with Kellum cable grips. Locate all junction box connections for the pump power cable above the pump room where flooding can potentially occur and also for ease of disconnection/re-connection of the cable. Motor cooling jacket shall be equipped with pressurized flushing connection.

7.3.7.1.3 Wet Well Submersible Pump Installation (Special Station Requirement):

This type of pump is typically not allowed due to the higher maintenance requirements. Where this type of pump may be required (i.e. application in pump station retrofit projects), the following features shall be provided: Generally provide the features described as above for dry pit submersible pump applications. Also, pumps shall have a Factory Mutual, or UL explosion-proof rating. Install a ¼-inch bleed hole on the discharge line of the pump at the 90° elbow fitting prior to penetration through the wet well for removal of air (when the wet well has been drained). Provide Type 316 stainless steel cable and guide rails for installing the pump. Submersible pumps for wet well installations are prohibited except when otherwise directed by the City. This wet well installation is for dewatering pumps only and shall not be allowed for wastewater pumping applications.

SECTION 7.4 PIPING AND APPURTENANCES**7.4.1 ISOLATION VALVES**

- 7.4.1.1 Dry Well Isolation Valves:** Dry well isolation valves inside the station shall be rising-stem Type 316 stainless steel "solid wedge" type sewage application gate valves with the following features: Type 316 stainless steel stem, bronze gate and valve body seat inserts, Type 316 stainless steel fasteners in wetted areas, and fusion-bond epoxy coating on all interior and exterior surfaces. Currently available valves of this type are Hilton or Mueller, Inc., no known equals.
- 7.4.1.2 Valve Operators:** Valves shall operate with hand wheels, and have geared operators for ease of turning. Preferable valve stem orientation shall be vertical.
- 7.4.1.3 Valve Accessibility:** All valves in the dry well shall be accessible from the floor, 6 ft above floor maximum.
- 7.4.1.4 Elevated Valve Access:** Elevated valves mounted more than 6 feet above the floor shall be accessible from the stairwell, special platforms, landings, or catwalks installed as required for access. A ladder with safety climb equipment and harness shall be provided on all platforms and catwalks.
- 7.4.1.5 Suction Valve Extensions:** Suction valves shall be fitted with extensions to the grade level (or the floor above if below grade station). Suction valves shall be fitted with hand wheels in the dry well and hand wheels (or recessed and covered valve keys as required) at the level above. The extension shall be equipped with two (2) U-joint type fittings at the valve to allow ease of rotation in the event of minor misalignment of the extension installation.
- 7.4.1.6 Buried Valves:** For buried applications, provide fusion-bonded epoxy coated "solid wedge" gate valves with water tight bonnets and buried service gear operators. Provide a valve extension to the ground level for operating the valve. Locate valves within the station's fenced-in area. Isolation valves outside the station on the inlet and force main shall be located as shallow as possible.
- 7.4.1.7 Wet Well Isolation Valve:** Locate a pressure isolation sluice gate on the wet well inlet sewer with the following features: stainless steel frame with stainless steel guide inserts, slide and stem; rising stem type (provide stem plastic cover tube to protect from dirt); actuation by square nut or wheel stand accessed from top of wet well. Apply fusion epoxy coat on all ferrous items.

7.4.1.8 **Underground Valves in Vaults (Special Station Requirement):** Where difficult soil and/or site conditions exist such that buried valves may not be easily accessible for emergency repairs, locate valves in a vault for easy access to valve bonnet pickings, gear operators and/or pressure greasing fittings. This would include force main isolation valves and emergency pump connection valves (refer to Section 7.2.8 on Force Mains).

7.4.2 CHECK VALVES

7.4.2.1 **General Features - Rubber Flapper Check Valves:** Specify rubber flapper swing check valves. Wherever possible, install the check valve in a horizontal position to prevent pipe clogging from sedimentation. Valves for vertical installations must be approved. The valve shall have an access plate for cleaning debris from the check assembly. The valve seat angle shall be 45 degrees to the flow axis of the pipe. The flapper shall be Buna-N rubber coated steel disk. The disk shall attach to the valve body by an integral fabric-reinforced flexible Buna-N hinge section. Disk swing of approximately 35 degrees is required to full open position. Wetted surfaces in the valve body shall be epoxy coated.

7.4.2.2 **Specific Valve Features:** Specify a proximity switch to indicate when the valve is open or closed, a backflow actuator to permit the valve flapper to be opened by an outside means and minimum solid passing size of 3-inch diameter sphere. Specify rubber flapper check valves manufactured by Vlamatic Surge Buster, no known equal.

7.4.2.3 **Surge Control Check (Special Station Requirement):** Where large discharge heads or flows may cause water hammer, install rubber flapper check valves with a spring to accelerate the disk closure thus preventing reverse fluid flow and valve slam. Valve manufacturer recommendations on spring requirements shall be obtained for each application.

7.4.2.4 **Proximity Switch:** Install a proximity type limit switch on the check valve. Limit switch shall indicate valve open/closed condition, and interlock with pump controls per standard schematic. Switch and wiring shall be NEMA 6P for protection from water. (Note: This switch, indicating a check valve failure to open condition, shall operate with a time delay control relay initiated by pump call to stop the pump motor and prevent motor damage and signal a pump fail alarm should the sensor not be actuated within the set time delay. It shall also prevent a pump start if the check valve is leaking backflow and potentially spinning the pump in a reverse direction).

7.4.3 PIPING AND FITTINGS

- 7.4.3.1 **Ductile Iron Pipe:** Sewage suction and discharge piping and fittings installed in the wet well and the dry well shall be ductile iron (DI).
- 7.4.3.2 **Threaded-On Ductile Iron Flanges:** Threaded-on ductile iron flanges shall be made up with epoxy on the threads for sealing for corrosion protection.
- 7.4.3.3 **Make-Up Length Piping:** Provide flanged by plain end pipe fittings and restrained tie rod coupling section for make-up length fittings.
- 7.4.3.4 **Pipe Disassembly Lengths:** Discharge piping shall be fitted and connected so that there are no lengths of pipe that cannot be disassembled and removed from the station utilizing the station overhead crane rail hoist.
- 7.4.3.5 **Approved Pipe Joints:** All pipe joints must be restrained. The following types of joints are acceptable: flanged and dresser type coupling restrained by tie rods. Threaded on type DI pipe flanges are allowable. For this type the DESIGN ENGINEER shall specify assembly per AWWA standards.
- 7.4.3.6 **Non-Approved Coupling Fittings:** The following fittings are not allowable and shall not be used in design: rubber bellows-type couplings and flange coupling adaptors that utilize set screws for restraint.
- 7.4.3.6.1 **Victaulic Couplings (Special Station Requirement):** These fittings are not generally allowed. However, for retrofit projects and where piping space is critical, grooved pipe couplings may be utilized with proper bracing against lateral and rotational movement.
- 7.4.3.7 **Restrained Couplings for Ease of Piping Alignment:** On suction and discharge piping connected to each pump and on the discharge manifold horizontal and vertical runs, install two flexible sleeve couplings with tie rod thrust restraint to absorb piping misalignment and prevent stress in the pump and piping and for ease of piping removal.
- 7.4.3.8 **Piping Supports and Bracing:** Piping supports shall be provided under the suction and discharge lines. Piping supports shall be designed to support the piping runs both vertically and horizontally. Bracing shall be provided to resist the maximum expected pressure transient forces. Typically, the end of the manifold will be braced to the adjacent wall for this purpose.
- 7.4.3.9 **Seismic Zone 4 Design:** All Piping supports shall be designed to meet Seismic Zone 4 requirements.

- 7.4.3.10 **Base Elbows:** Base elbow fittings shall be installed on pedestals at vertical bends. The vertical piping run shall be braced horizontally to the wall so that base elbows are not required to resist any horizontal thrust loads.
- 7.4.3.11 **Manifold Configuration:** For manifolds, utilize wye fittings rather than tee type fittings. Connect discharge piping from individual pumps horizontally into the side of the manifold.
(Note: to minimize deposition of solids at check valves).
- 7.4.3.12 **Manifold to Force Main(s) Piping Configuration:** Design dual force mains that can be operated independently. Within the dry well pump room, the manifold shall wye into two separate force mains. Each shall be provided with an isolation valve downstream of the wye (Note: this configuration allows operation of any pumps through either force main, while the other force main is isolated for maintenance/repair).

7.4.4 **FORCE MAIN DRAIN LINES**

- 7.4.4.1 **Force Main Drain Lines to Wet Well:** Within the pump room, provide a drain line with isolation valve from each discharge force main, and discharge to the wet well (Note: this configuration will allow draining back the entire force main while the other is operating in the event of a force main break).
- 7.4.4.2 **Force Main Drain Lines (Special Station Requirement):** For large pump stations (greater than 3 mgd) or stations with critical flooding concerns (i.e., existing electrical equipment located in below-grade pump room not permitted for new pumping stations or retrofits), the drainage from the force main(s) and any sump pump installation in the dry well shall be discharged to the sewer manhole immediately upstream of the wet well provided the wet well contains an inlet gate. The gate shall be closed to prevent further flooding and to allow repair work on any pump room leakage.

7.4.5 **SMALL APPURTENANCE PIPE FITTINGS**

- 7.4.5.1 **Small Appurtenance Piping:** Two-inch diameter or less piping appurtenances connected to station DI piping (i.e. air release valve connections, seal water drain lines, or seal piping drain lines) shall be Type 316 stainless steel. Galvanized steel shall not be permitted. Install corrosion isolation nylon bushings when mounting dissimilar metal pipe fittings such as bronze air release gauge cocks on manifold piping.

7.4.6 STAINLESS STEEL BOLTING

7.4.6.1 **Dry Well Fasteners:** All dry well pump and pipe fasteners shall be Type 316 stainless steel.

7.4.6.2 **Wet Well and Buried Fittings Fasteners:** All wet well fasteners and anchor bolts and all fasteners for buried fittings shall be Type 316 stainless steel.

7.4.7 AIR RELEASE VALVES

7.4.7.1 **Installation Locations:** Locate air release valves on the discharge piping of the following:

7.4.7.1.1 **Flooded Suction Pumps:** Provide a manual ½-inch stainless steel ball valve on the top of the volute discharge to remove air after servicing prior to putting pump back in service.

7.4.7.2 **Air Release Valves:** Install two sewage application combination type air release and vacuum valves (Note: two for redundant operation to allow removal for maintenance) on discharge manifolds located at the piping penetration from the dry well. Valves are typically 2-inch size. Provide an independent connection with isolation valve for each valve to the discharge manifold. Brace the valves to the station wall. This installation shall be accessible by a catwalk platform for maintenance. Specify sewage application combination type air release valves, Vent-O-Mat, no known equals.

7.4.7.3 **Stainless Steel Pipe Fittings:** As specified above, for each air valve assembly or gauge cock, the pipe nipple connection to the manifold and all other piping in the assembly shall be Type 316 stainless steel, including a ball valve and pipe union on the assembly to allow maintenance and removal of each air release valve.

7.4.7.4. **Air Valve Drain Piping:** Air release valve discharge piping shall be piped to the station drain sump.

7.4.7.5 **Self-Priming Pumps (Special Station Requirement):** For retrofit projects where these types of pumps are in existence (Note: this type of pump is not approved for new station designs), install sewage type air release valves on the discharge side of the pump (discharges periodic air in the line due to cavitations or on startup). The internal check valve in the pump holds vacuum in the suction line. Route the discharge hose into the wet well so that the discharge is always submerged to prevent loss of vacuum in the bowl if the check valve seat clogs from debris. Piping from the air release valve to the sump shall be 1-inch Type 316 stainless steel.

7.4.7.6 **Submersible Pumps (Special Station Requirement):** For retrofit projects where these types of pumps are existing (Note: this type of pump is not approved for new station designs), locate the following equipment in a discharge valve vault: sewage-type air relief valve (Vent-O-Mat with no known equals), discharge check valve and isolation valve. Also, ½-inch drilled and tapped hole with piped gooseneck may be installed on the discharge piping vertical elbow penetration in the wet well for manual continuous air release.

7.4.8 **SCHEDULE OF PIPE MATERIALS**

7.4.8.1 **Schedule on Mechanical Drawings:** Include data schedule on the mechanical drawings with the following information for each pipe valve, and appurtenance to be provided: item number, size, type, quantity, remarks, and specification reference.

SECTION 7.5 ELECTRICAL, CONTROLS, AND INSTRUMENTATION**7.5.1 GENERAL**

Electrical controls and instrumentation have been standardized by the City. The DESIGN ENGINEER shall obtain a copy of these standards from the City, and shall incorporate them in the design after making modifications to meet project specific requirements. The electrical control and instrumentation system shall also be in compliance with the Public Utilities Department, Wastewater Collection Division, Design Standards.

7.5.2 POWER SWITCHGEAR AND DISTRIBUTION**7.5.2.1 Lockout Safety**

- a. Provide a disconnect to open the incoming electrical power to ensure power is cut off while working on switch gear.
- b. Provide a lockout device and a tag-out sign on the handle of circuit breaker or disconnect switch to inhibit connection of circuit during maintenance. Lockout devices shall have the capability to attach at least two locks.
- c. Install an emergency stop switch at each pump mounted on the wall or on a pedestal, within sight of the motor. If not possible to install within sight, install a sign directing the location of switch. Install the NEMA 6P rated lockout safety switches (Gianni or approved equal).

7.5.2.2 Circuit Breakers: Use of motor circuit protectors for magnetic starters shall be limited to motors rated below 150 HP. The use of motor circuit protectors (MCPs - fully magnetic circuit breakers) on motors 150 HP and larger can cause MCP trip during start-up and the setting cannot be adjusted beyond the 13 times FLA (per NEC). Use thermal magnetic circuit breakers for motors larger than 150 HP. Additionally, when solid state starters are used, the circuit breakers should be thermal magnetic type.

7.5.2.3 Switchgear Rating Coordination

- a. Feeder circuit breakers shall be designed to trip when a fault occurs at an immediate downstream location and will not affect the next higher upstream main circuit breakers from the fault.
- b. A short circuit fault analysis shall be performed to determine levels of fault current throughout the facility. Calculation procedures and methods shall be in accordance with IEEE Red Book, Recommended Practice for Electrical Power Distribution for Industrial Plants. The

selected electrical equipment interrupting and withstand ratings shall be based upon results of this study.

7.5.2.4 **Line Power Monitoring:** The following line power failure conditions shall be monitored by protective devices such IQ Data Plus II (brand name) with interlock protection: phase sequencing; loss of phase; unbalance phase current; high/low voltage. In the event that any of these conditions are detected, the controls shall prevent power from being distributed.

7.5.2.5 **Ground Fault Protection**

- a. The project specifications shall include a requirement for the Contractor to provide a competent independent sub-contractor who will test and provide written certification of complete ground fault testing and verification.
- b. Ground fault protection (GFP) shall be provided on main circuit breakers when the service is 1000A or larger on a 150V to ground system.
- c. *(**Special Station Requirement**). A permanently installed ground fault meter shall be installed in the motor control panel.*
- d. Ground fault protection shall be provided in the feeder circuit breaker for each motor.

7.5.2.6 **Grounding System:** Install a grounding system per California Electrical Code (CEC) requirements. Ground connections to the buried grounding system shall be made at all electrical enclosures and equipment. Ensure adequate corrosion protection of the grounding system and bare copper grounding wire. All ungrounded connections shall be exothermic (welded) connections. No bolted connections shall be buried. Grounding to cold water piping is not acceptable.

7.5.2.7 **Motor Starter Design**

- a. Reduced voltage type solid state motor starters with manual bypass contactors shall be required for all motors larger than 20 hp. The requirement for the addition of soft starters shall be determined by the City during design. The solid state motor starters shall have an adjustable current limit of 50 to 150 percent of full load current and acceleration time adjustments. The solid state starters shall have over temperature protection.
- b. All motor starters shall be equipped to provide under-voltage release and overload protection on all three phases. Provide a "Motor Saver, Inc." protective device with digital fault record on each motor starter. Motor

starter coil and contacts shall be easily replaceable without removing the motor starter from its mounted position or the removal of phase conductors. Provide fuses on the primary and secondary sides of the control power transformers. Install a separate power control transformer for each motor starter. For small appurtenant equipment and other applications, motor starters shall be vertical actuation type and manufactured by Allen-Bradley, Inc., or approved equal. Motor starters shall meet NEMA standards. Overload relays shall be of block-type, utilizing eutectic melting alloy type spindles, and shall have visual trip indication with trip-free operation. Pressing of the overload reset lever shall not actuate the control contact until such time as the overload spindle has reset. The reset lever shall be accessible through the control panel door. Resetting of the overload reset lever will cause a snap-action control contact to reset, thus reestablishing a control circuit. Overload relays shall be manually reset only and not convertible to automatic reset. Trip setting shall be determined by heater element only and not be adjustable settings. Overload elements shall be melting alloy type.

7.5.2.8 **Motor Control Center Switchgear Equipment**

- a. Motor control center switchgear equipment shall be factory prepared sections manufactured by Allen-Bradley, Inc., or approved equal.
- b. All motor control center circuit breakers and motor starters shall be NEMA rated and UL rated.

7.5.2.9 **Wiring and Bus Bars**

- a. Stranded copper wire shall be used for all power and control wire sizes. Solid copper wire is not acceptable. No aluminum wire or connectors shall be allowed for any station wiring.
- b. The motor control center and other control panels shall have bus bars and connectors constructed of tin-plated solid copper. All wiring within the MCC shall be pre-wired in the factory to reduce field wiring by Contractor. NEMA Class II B wiring shall be specified.

- 7.5.2.10 **Seismic Braces:** Seismic braces shall be installed on all electric service cabinets and other free standing equipment per code requirements. Provide a detail drawing of the seismic braces in the design drawings. All electrical equipment shall be anchored to satisfy CBC Zone 4 requirements.

7.5.2.11 House Service Panel

- a. The service breaker panel for lighting and auxiliary equipment shall have balanced loads within 15% for each phase.
- b. The panel shall have its own transformer and not rely on a transformer in the control panel for service voltage.

7.5.2.12 Electrical Conduit

- a. Underground conduit shall be Schedule 40 PVC and concrete encased. Underground conduit shall be connected with water-tight glued joints. Stub-ups shall be galvanized steel, Robroy or approved equal. All couplings and fittings for stub-up shall be coated and threaded. Use long radius conduit fittings to allow pulling cable.
- b. Above-ground conduit and stub-ups shall be rigid galvanized steel, PVC coated 40 mils thick exterior and 2 mil thick phenolic on the interior. All exterior PVC coating shall be green in color.
- c. The Contractor shall provide a pull cord in completed conduit installation for future use.

7.5.2.13 Conduit Routing Schedule: Provide a completed table in the design drawings that shows the conduit routing schedule as shown in Table 7.5-1:

TABLE 7.5-1

CONDUIT ROUTING SCHEDULE

CONDUIT AND WIRE SCHEDULE						
CABLE/ RACEWAY NUMBER	CONDUIT SIZE	WIRING		FROM	TO	REMARKS
		QUANTITY	SIZE			

7.5.2.14 Electrical Outlets

- a. Provide 120 volt electrical outlets in the station for operation of miscellaneous station equipment and/or repair power tools. All outlets below grade and at exterior locations shall be GFI (ground fault

interrupter) protected by GFCI (ground fault circuit interrupter) circuit breakers at panels.

- b. Provide two (2) 230 volt, 1 phase, 30-Amp outlets in the MCC room for supplying power to emergency breathing apparatus that is used by personnel when entering the wet well.
- c. All outlets shall have wet location covers to protect against splashing even when receptacles are in use.

7.5.3 INSTRUMENTATION AND CONTROLS

7.5.3.1 **General:** This Section describes the general features of the standard design of electrical controls and instrumentation. Electrical controls and instrumentation have been standardized by the City. The DESIGN ENGINEER shall obtain a copy of these standards from the City, and shall incorporate them in the design, after making modifications to meet project specific requirements.

7.5.3.2 Dedicated Gas Monitoring

- a. Methane/explosive gas, hydrogen sulfide, low oxygen, and carbon monoxide (CO) detectors shall be installed in the dry well. Methane/explosive gas, and carbon monoxide detectors shall be installed in the power plant room. Methane sensors shall be infrared types which do not require periodic calibration.
- b. Gas detection equipment shall be Sierra Monitor Corporation, Control Unit (electrochemical sensors), and Crowcom Corporation, Cirrus Model (infrared sensor), for standardization of this safety equipment with other pump stations.
- c. The gas detectors shall be calibrated to alarm at the following set point gas concentrations: Combustible gas - 10% LEL; H₂S - 10 ppm; O₂ high - 23%; CO - 35 ppm.

7.5.3.3 **Flow Meter:** The Contractor shall provide Transducer “Transit Type” ultrasonic flow meter with panel display on each discharge manifold, Controlotron Incorporated, Model 1010, or approved equal.

7.5.3.4 **Level Control:** Provide ultrasonic level indicator, PULSAR ULTRA 5, or two pressure transducers for sewer application as level measurement. The decision to use either the ultrasonic transducer or the pressure transducers will be determined during the early stage of design based on sewage basin characteristics.

Transducers shall be stainless steel and submersible rated, KSI series 700. The transmitter output shall be selected per electrical design requirements (4-20 mA, 0-5 VDC, etc.). The higher of the two signals shall be selected by the control system for the pump start/stop and control purposes. Install transducer(s) in the wet well so that cleaning, maintenance or replacement can be done without entering the wet well. A junction box near the wet well shall be installed for connection/termination of transducer(s) cables. This will limit the length of transducer(s) cables to a minimum. Conduit run for the transducer(s) cables shall be two (2) inches diameter without conduit bodies, if possible.

If an ultrasonic level indicator is used, install a float switch as back up with provisions for cleaning, maintenance, or replacement.

7.5.3.5 **Pump Control and Alarm Circuit "Ladder Logic" Diagrams**

- a. The DESIGN ENGINEER is referred to **ATTACHMENT 3** in this Sewer Design Guide, and shall make the necessary modifications to include project-specific requirements (i.e., number, size of pumps, above/below grade facilities, etc.).
- b. Specify that the "as-built" electrical drawings shall show the actual "as-built" wire number labels to conform to PUD standards. (All wires and control devices in the Control Panel shall be labeled by the Contractor).

7.5.3.6 **Pump Control Description:** A pump control sequence description shall be provided in the design specifications and shall also be included in the Summary of Operation Section of the Operations & Maintenance Manual. The description shall be in accordance with the guidelines in **ATTACHMENT 3**.

7.5.3.7 **Calibration Schedule:** Provide a control device calibration range schedule on the design plans for reference during installation and adjustment of the control devices.

7.5.3.8 **Process Instrumentation and Control Diagram:** Include a process instrumentation and control diagram in the design drawings. Show all pump station process components for clarity.

7.5.3.9 **"Fail-Safe" Design Alarm Relays**

- a. Design alarm relays to be normally energized during normal pump station operation. Relay "fail-safe" design shall thus alert operators through the telemetry system should an alarm condition occur that de-energizes the alarm relay as designed, or should an alarm relay fail and de-energize.

- b. Where electro-mechanical relays are installed, provide standard relays with octal base mounting to simplify replacement of defective units.
- c. Provide adequately sized UPS system for maintaining seal-in of relays during ATS operation.

7.5.3.10 **Emergency Motor Controls**

- a. Motor winding imbedded "motor high temperature" pump interlock.
- b. Pedestal mounted emergency stop push button (NEMA 6P submergence rated) at pump unit.
- c. For protection of below grade MCC/control panel locations in event of flooding, "Dry well flood" float switch shall cause main breaker and emergency generator breaker shunt disconnect.
- d. Emergency stop of generator upon methane/explosive gas alarm by closure of natural gas valve with normally closed (NC) solenoid valve located outside generator room on natural gas line. The solenoid shall be operated from DC power generator or battery. Provide hazardous gas alarm warning light and audible alarm at panel.

7.5.3.11 **Motor Starter Circuit Hand Operation**

- a. Design this circuit so that in hand position, the circuit interlocks, including the motor over-temperature and motor starter overload contacts, shall be "hard relay wired" outside the PLC to allow operation of this circuit in hand should failure of the PC occur.
- b. Design control circuit so that for H-O-A switch selection to "off" or "manual hand" operation or lockout of circuit breaker does not result in alarm.

7.5.3.12 **Emergency Stop:** Provide pump emergency stop push button switch controls adjacent to each pump installation. This control shall include a lock-out feature. Switch shall be NEMA 6P submergence rated, Gianini Inc., or approved equal.

7.5.3.13 **Pump Status Indicator Lights:** For each pump include the following indicator lights: pump running (green); pump off (red); pump failure (red).

7.5.3.14 **Pump Run Time:** Provide an externally non-resettable elapsed time meter for each pump in service. The run time meter for each pump shall be located at M.C.

7.5.3.15 **Telemetry Alarms:** Refer to **ATTACHMENT 3** in this Sewer Design Guide.

7.5.3.16 **Station Status and Alarm Condition Annunciator Panel:** Provide an annunciator panel on the control panel to indicate normal pump station status conditions and all alarm conditions. The alarm conditions to be indicated shall correspond to the telemetry alarm points. Refer to **ATTACHMENT 3**. The annunciator shall be Rochester Instrument System Model AN-3100C Series.

7.5.3.17 **Panel Indicator Light Bulbs:** All indicating lights and alarm annunciator lights shall be of the "push-to-test" type.

7.5.3.18 **Alarm and Control Relay Resets**

- a. Alarm display relays shall require a manual reset actuation (i.e., reset of alarm indication shall not occur automatically after an alarm condition clears).
- b. Motor trips shall require a manual reset and shall not occur automatically after a trip/alarm condition clears.
- c. Provide a master alarm with buzzer and acknowledge (silence) function. The buzzer shall be loud enough to be heard near the pump station door, but not too loud to cause neighborhood homeowners complaints.

7.5.4 **TELEMETRY**

Refer to **ATTACHMENT 3**

7.5.5 **ALTERNATE BACKUP POWER**

7.5.5.1 **Emergency Backup Power:** Provide a secondary emergency power supply. There are two options: a second SDG&E service from another service area or an onsite emergency engine generator.

7.5.5.1.1 The emergency generator set shall be designed with the following features:

- a. The generator set shall have sufficient capacity to supply all starting current requirements. It shall be sized to have sufficient capacity to supply maximum load conditions after load factor has been taken into account. Upon application of the rated load, the instantaneous voltage dip shall not exceed 20% and shall recover to rated voltage within one second. (Note: Ensure that the pump motors specified can withstand the low

voltage/high current conditions during ATS emergency generator unit start up). The generator unit shall be sized to sequentially start all pumps at the station in both the normal operation “soft start” mode or emergency operation “across the line” mode. It shall be ensured that in the event that loss of normal station power occurs, the pump motors come to stop before power is re-applied from the alternate source.

- b. The generator set shall be installed on seismic Zone 4 rated spring isolation supports to reduce vibration from the unit into the foundation. An all directional double acting earthquake snubber, Mason Industries “Vibrex” or approved equal, shall be specified. Conduits, ventilation ducting, fuel pipe lines, etc. needed for the operation of the generator unit shall have sufficient flexibility to accommodate movement due to seismic activities.
- c. The generator set shall have an electronic governor controller to hold the engine speed to within ½ cycle per second of rated speed.

7.5.5.1.2 The control panel shall be designed with the following features:

- a. The control panel shall be equipped with the following instrument displays (analogue or digital readouts): voltmeter; ammeter; frequency meter; engine oil pressure; engine temperature; hour run meter (non-resettable); and battery voltage or charge.
- b. The control panel shall be equipped with voltage output adjust, frequency adjust, panel light, test/off/auto switch, lamp test switch, alarm reset switch, and alarm indicator lights/buzzer. The test/off/auto switch control is for testing and exercising the engine unloaded. Provide a timed auto exercise control feature. The City’s preference is that the cool-down period time delay be located in the transfer switch. (Ref. Subsection 7.5.5.5).
- c. The control panel shall have automatic shutdown with indicators for the following conditions: over-crank; over-speed; under/over voltage; low oil pressure; and high engine temperature. It shall include non-shutdown condition indicators (light and audible alarm): low-fuel (diesel engine); low fuel pressure (natural gas fuel); low engine temperature; pre-low oil pressure; pre-high temperature; low battery voltage; high battery voltage; and main fuel tank rupture (diesel engine). Include indicator light and audible alarm also when run/off/auto switch is not in “auto”.
- d. The control panel shall include a “common alarm” point (including run/off/auto switch not in auto) and running status of the engine point for remote SCADA monitoring. The common alarm point is activated

whenever a condition does not allow an automatic startup of the generator unit.

7.5.5.1.3 The engine shall be designed with the following features:

- a. The engine shall be equipped with an engine block coolant heater. The heater units shall be rated to ensure a preheating temperature of 100°F.
- b. Install an oil drain line hose extension with a ball valve and plug end fitting from the sump to the side of the engine unit for ease of routine oil changes. Similarly, install a valved coolant drain line. Provide an oil pan spill dike under the engine to hold spilled oil from the crankcase.
- c. The engine shall be water-cooled only.
- d. Provide an air filter head loss indicator (Donaldson, Inc. or approved equal) that indicates a need for filter replacement due to high head loss through the filter.

7.5.5.1.4 Miscellaneous or Accessory

- a. The battery trickle charger shall be per EPS manufacturer specification/requirement. It shall be adjustable and equipped with an ammeter and voltmeter.
- b. Provide a hospital-grade critical type muffler and sound dampened inlet air louvers to reduce engine noise at the property line if required to meet noise control requirements. On the exhaust manifold, install a water drain trap, wrap the exhaust piping in insulation (non-asbestos type) and at the end install a flapper cover with a stop on the flap to prevent it from hanging open. Use stainless steel material for the exhaust system for stations located less than one mile from the ocean.

7.5.5.2 **Emergency Power Plant Fuel**

The preferred type engine is a natural gas powered engine. For emergency power plants on site, provide the following features:

7.5.5.2.1 **Fuel - Diesel: (Special Station Requirement)**

- a. Diesel engine units can be installed with special approval.
- b. The preferred fuel tank installation shall be double wall fuel tank with leak sensor on the generator unit. Provide proper venting and pressure relief valves for each tank.

- c. The fuel supply system shall include a day tank unit with automatic fuel pumping when using a separate fuel storage tank.
- d. Install a fire suppression system per National Fire Protection Code (NFPC) requirements in the power plant room.
- e. A portable power plant with trailer mounted diesel fuel tank can be considered at the site with prior approval.

7.5.5.3 **Transfer Switch - Automatic**

- a. The station shall have an interlock protected emergency power transfer switch to automatically start the generator in the event of loss of any phase of power, reverse power or low voltage brownout.
- b. The transfer switch shall include time delay controls for the following functions: prevent start/stop short cycling of the emergency generator due to momentary dips in line voltage; transfer the load to the generator when it is at rated voltage and frequency, return to line power with adjustable time delay when line power is restored, and initiate an engine shutdown [note: provide "programmed neutral" —time delay (i.e., adjustable 0-10 second to allow equipment to coast off before transfer) or in-phase monitor (i.e., large units to match generator-to-line phasing)]. Provide a timed auto exercise control feature. The City's preference is that the cool-down period time delay be located in the transfer switch. If the engine manufacturer requires that the cool-down period time delay be located in the engine controller, then this feature shall also not be included at the transfer switch. An instruction plate shall be located at the transfer switch specifying that the cool-down time delay is located at the engine controller. (Ref. Subsection 7.5.5.1.1)
- c. The generator shall have a disconnect plug and interlock at the transfer switch for isolation to prevent auto operation during maintenance.
- d. Transfer switch operation by Programmable Controller is allowable.

7.5.5.4 **Transfer Switch - Manual (Special Station Requirement)**

- a. The manual transfer system shall require the use of an enable key to sequentially open the line power service and then transfer to the emergency power service connection.
- b. The DESIGN ENGINEER shall ensure that the transfer switch is rated at the same amperage interrupting capacity (AIC) withstand rating as the line power service.

- c. The following warning sign shall be posted on the transfer switch panel:

"DO NOT TRANSFER POWER WHEN UNDER LOAD"

7.5.5.5 **Emergency Generator Installation Location**

- a. The emergency power plant shall normally be installed inside the station in a room dedicated to this installation.
- b. Where installed in a power plant room, eye-bolts or a crane rail hoist system shall be installed over the unit for assisting with maintenance and repairs.
- c. Where installed in a power plant room, a remote annunciator panel indicating the operational status of the generator shall be installed at the pump station motor control panel in order to monitor the status of the emergency power plant from that location.
- d. The generator room shall have a floor drain to sewer that includes the following features: drain line oil trap with water seal in sump area; roof vent stack.
- e. If approved for outside installation, the emergency power plant shall be installed under an overhead roof for protection from the elements. This overhead roof shall be equipped with a 115 volt electrical service and lighting. Power plants installed outside the building shall be installed inside a noise attenuating/security enclosure with access panels secured by padlocks. This enclosure and the generator control panel as installed at the site shall be completely secure from entry by rodents or other small animals. The enclosure shall include a view window to allow observation of the operating panel from the outside. In addition, a remote annunciator panel indicating the operational status of the generator shall be installed at the pump station motor control panel in order to monitor the status of the emergency power plant from that location.

- 7.5.5.6 **Emergency Plug-In Connection:** For stations without a dedicated emergency generator (i.e., some existing stations to be retrofitted), install a manual transfer switch and an emergency plug-in power connection to the station for use with a portable generator. The plug-in connector shall be a Kam-Lok, Inc. color coded "Posilok" system, or for services larger than 400 amps, a "Camlock" system.

7.5.6 OTHER STATION REQUIREMENTS

7.5.6.1 **Emergency Lighting:** Install an emergency battery-powered lighting system in the station (including stairwells) and provide lighted exit signs which are interconnected with the emergency lighting system at the station access doors.

7.5.6.2 Corrosion Control System (Special Station Requirement)

- a. Install corrosion control equipment as required to protect the station buried piping and force main, which can include the following: cathodic test stations; sacrificial anodes; impressed current anodes and; rectifiers; insulation flange kits; and pipe flange bonding wiring (for continuous bonding). Dielectric unions and nylon insulation bushings are to be installed between dissimilar metals in piping (i.e. brass fittings connected to manifolds), between pumps and inlet and discharge piping (to insulate from inductance current caused by motors and electrical grounding as required by the cathodic protection system).
- b. Install, as required to help prevent stray current interferences, electrical insulating blankets on cathodically protected pipelines at locations where foreign cathodically protected pipelines are crossed. Insulating blankets shall be installed midway between the crossing pipelines.
- c. The corrosion control system and protective coatings on the force main piping shall be designed to ensure protection for the useful life of the station (typically 50 years). Impressed current and galvanic anode beds shall be designed for a useful life of 20 years.
- d. Contact the Public Utilities Corrosion Engineer for additional information concerning the corrosion control system requirements.
- e. Also refer to Chapter 6 for additional corrosion protection requirements.

SECTION 7.6 VENTILATION**7.6.1 GENERAL REQUIREMENTS**

7.6.1.1 **Dry Well Required Air Changes:** DESIGN ENGINEER shall provide an adequate ventilation system as required by NFPA 820. No less than twelve continuous air changes per hour plus additional requirements for motor and switchgear cooling as required shall be provided for the dry well by a powered supply and exhaust system. Fan control switches shall be installed at accessible locations.

7.6.1.2 **Air Supply/Exhaust Locations:** Air shall be supplied into the dry well pump room at floor level and exhausted both at floor and ceiling levels. Air shall also be exhausted from the upper level motor control center room at ceiling level.

7.6.1.3 **Ductwork Materials:** Ductwork for all applications except wet well exhaust shall be constructed of aluminum with PVC coating/lining. Wet well exhaust ductwork shall be constructed of fiberglass reinforced polyester (FRP). All diffusers, registers, and dampers shall have nylon bearings, stainless steel shafts, and be PVC-coated aluminum or FRP matching the connecting ductwork material.

7.6.1.4 **Maintenance Access Covers:** Provide access covers for ease of maintenance of motors and fan pulleys.

7.6.1.5 **Location of Fan Installations:** Locate the fans at 7 ft above the floor, to be readily accessible with short portable ladders.

7.6.1.6 **Ventilation Filters (Special Station Requirement):** Install a pre-filter and a high-efficiency final filter on inlet vent ducting for noise attenuation and to minimize dust in the station. Filters shall be located for convenient maintenance access, and be provided with an access cover. Label the filter locations to alert the operator to the need for periodic maintenance of the filters.

7.6.1.7 **Rodent Proofing Openings:** Ventilation openings shall be provided with stainless steel screens to prevent the entrance of birds, rodents, and other small animals.

7.6.2 AVOIDING VENTILATION CROSS CIRCUITING

7.6.2.1 **Ventilation Short-Circuiting Considerations:** Locate the ventilation air inlet upstream of all exhaust air outlets relative to the prevailing wind direction.

The minimum separation between any air inlet and discharge outlet shall be 10 feet. Ensure that ventilation inlets are not located where emergency generator exhaust or wet well venting can be drawn into the station ventilation. Both these potentially hazardous discharges should be vented at the roof level to provide dispersion.

7.6.3 NOISE ATTENUATION

7.6.3.1 **Maximum Allowable Noise Levels at Property Line:** Maximum allowable outside sound level at the property line shall be 45 dbA. Install acoustic doors, inlet and outlet baffles/silencers; locate fans away from the inlets and outlets or other features on the station as required. The generator room shall be installed with acoustic panels on the walls and ceiling as necessary.

7.6.3.2 **Maximum Allowable Noise Levels Inside Station:** Provide acoustic liners in the ducting and take any other measures as required to minimize ventilation noise inside the station such that the noise does not interfere with voice communication, or constitute a hearing hazard.

7.6.4. GENERATOR ROOM VENTILATION

7.6.4.1 **Required Continuous Generator Room Ventilation:** Generator rooms, where natural gas or diesel powered generators are installed, require a minimum of 15 air changes per hour continuous powered supply and exhaust.

7.6.4.2 **Ventilation During Generator Operation:** Provide additional powered ventilation/cooling as required for cooling and combustion air for the engine unit. Generally, for above grade facilities, the inlet air is provided by a large set of louvers with power open/close on generator start. For the large air flows required for generator cooling, efficient high air flow rate fans and ducting is required and ducting should be laid out to minimize severe changes in direction.

7.6.5 VENTILATION/ODOR CONTROL OF THE WET WELL

7.6.5.1 **Odor Control System:** Provide for passive venting through a properly sized odor control canister containing activated charcoal. Charcoal canisters shall be of a design which will permit replacement of the media when required. Install PVC piping with valving to allow bypass venting around the canister as required. If charcoal canisters are not immediately needed, install required piping only, to be used in the future.

When conditions such as long residence times in the wet well and/or incoming sewer lines, or if the incoming sewage organic concentration is high and elevated odor emissions are probable, and as directed by the City, provide a foul air wet well exhaust fan located between the wet well and the carbon canister. The wet well foul air exhaust fan shall be sized to provide an air flow rate of 1.5 times the station design pumping rate in terms of cubic feet per minute. The exhaust fan shall be constructed of non-sparking corrosion resistant material and be equipped with an explosion proof motor. Maximum exhaust fan noise at the property line shall be 45 dbA. Provide PVC ventilation ducting to allow bypassing the wet well foul air around the fan and directly into the carbon canister.

7.6.5.2 **Power Ventilation/Odor Control (Special Station Requirement):** Wet wells requiring routine personnel entry for normal operation and maintenance shall be mechanically ventilated (supply and exhaust) continuously in accordance with NFPA 820 to provide 20 air changes per hour. Provide an activated charcoal canister on the exhaust for odor control. Size the canister to provide one year of treatment at the anticipated air flow rates and hazardous gas concentrations. Provide a spare redundant canister. Maximum blower noise at the property line shall be 45 dbA; install a noise attenuator as required. Blower shall be constructed of corrosion resistant materials such as FRP. Exhaust blower shall be located downstream of the activated charcoal canister. Ducting shall be FRP and, where installed in an outside location, shall be coated with an ultraviolet resistant coating such as polyurethane. Also provide a valved bypass for passive venting around the blower and canister.

7.6.6 DEHUMIDIFIER

7.6.6.1 **Dehumidifier Installation (Special Station Requirement):** For underground stations with below-grade control panels, provide an electric dehumidifier on a shelf adjacent to the panels.

7.6.7 AIR CONDITIONING/COOLING SYSTEMS

7.6.7.1 **Electrical Rooms (Special Station Requirement):** At inland locations where the ambient air temperature can exceed 90°F during certain seasons, or where required by the City, the motor control room shall be supplied with air conditioned 80°F maximum air supply and shall be ventilated at a minimum of 6 air changes per hour. Filters shall be as specified under “General Requirements”, except that pre-filters shall be the washable-type.

- 7.6.7.2 **Panel Cooling: (Special Station Requirement):** Where required for VFD units or other specialized electronic equipment, provide dedicated panel air filtration and/or air conditioning equipment for special treatment of the panel ventilation air. Filters shall be as specified under “General Requirements”, except that pre-filters shall be the washable-type.

SECTION 7.7 DRY WELL**7.7.1 GENERAL REQUIREMENTS**

7.7.1.1 Above-Grade Building Construction: Pump stations shall generally be constructed with an above grade building housing the electrical panels, motor control center, control panels and pump motors.

7.7.1.2 Stairway Access: All pump stations shall generally have stairways constructed for access to all levels of the dry well. Stairways may be constructed of cast-in-place concrete or anodized aluminum structural members. Stairs shall be equipped with safety rails, kick plates, non skid nosing plates or safety treads, and safety chains (at access openings as required). Where aluminum safety rails are installed on cast-in-place concrete stairs, provide rubber corrosion insulating strips at contact points with concrete.

7.7.1.3 Underground Station Access Stairs: Where stations are constructed without an above-grade building, stairways for access into underground stations shall be installed instead of ladders. Provide railings and/or multiple detachable chains around stairway access openings for employee and public safety. Install nonskid stair safety tread. Opening the dry well door shall automatically light the stairway. Stairways shall also be constructed between floors.

7.7.1.4 Underground Station Equipment Hatches: For safety reasons, the dry well for underground pumping stations shall have two separate access hatches in addition to the stair access hatch. One access is for personnel entering by safety tripod and the other for removal of equipment. Access floor doors shall be H-20 load rated, dual leaf type fitted with stainless steel hinges and stainless steel hydraulic in a closed tube, spring balanced doors requiring a maximum force of 40 lbs. Provide a recessed padlock compartment in the doors. Opening of stair access hatch shall automatically turn on the lights.

7.7.1.5 Personnel Access to Equipment-Elevated Platforms: All equipment requiring routine maintenance or operation (i.e., isolation valves, air valves, pump shaft U-joints, eye bolts for chain hoist attachment, etc) that cannot be designed to be accessible from the floor level, shall have access provided by catwalk platform. Provide a ladder access to the platform. The ladder shall be provided with installed safety climb rail and harness equipment, and a “ladder up post”, hand rail or safety post that extends 3 feet above the ladder for safe access, Miller Industries or approved equal.

7.7.1.6 Rolling Stairway for Equipment Access (Special Station Requirement): An alternative to the platform access described in the preceding subsection, is installation of a rolling stairway in the pump room and/or intermediate levels. This stairway is to provide safe access to the equipment described in the

previous subsection that requires routine access during operation and maintenance.

- 7.7.1.7 **Fire Extinguishers:** Install fire extinguishers rated for Class A, B, and C fires in the motor room, motor control center room, pump room and standby generator room.
- 7.7.1.8 **Fire Rated Doors:** Install NFPA-approved fire resistant door between the standby generator room and the rest of the dry well.
- 7.7.1.9 **Fluorescent Lights:** Rapid starting type fluorescent lighting shall be used.
- 7.7.1.10 **Safety Lighting:** Provide battery charged emergency lighting in all areas and in stairways.
- 7.7.1.11 **Skylights: (Special Station Requirement):** Install skylights in the pump station roof over the motors and standby generator for natural lighting during maintenance (if practical and/or structurally feasible). These skylights/roof hatches should also be useable for removal of pumps, motors, and power plant equipment through the roof if required by maintenance operations. Install the skylights/roof hatches with inside latches operated by an extension pole. Install a personnel access hatch reached by an inside ladder for access to the roof. Skylights shall incorporate reinforced metal bars to prevent vandalism/break-in through the skylight.
- 7.7.1.12 **Safety Warning Signs:** Safety warning signs shall be posted near all hazardous equipment in plain, unobstructed view and shall include warnings for automatic starting of pumps and other equipment. Warning signs shall include the following: “Warning Automatic Starting of Equipment”, “Warning High Voltage” (at Main Service Center and Motor Control Center), and “Warning Hazardous Chemicals” (at odor control systems).
- 7.7.1.13 **Concrete Surface Sealing:** All interior concrete floor surfaces of the dry well shall be protected with a sealer/hardener finish coating.
- 7.7.1.14 **Non-Skid Coating:** Provide non-skid type floor finish coating around equipment where maintenance will be performed.
- 7.7.1.15 **Equipment Maintenance Clearance:** All equipment shall have adequate (32 feet minimum) clearance from other equipment and station walls for maintenance and repair work space requirements.
- 7.7.1.16 **Safety Guards:** OSHA Safety guards shall be placed around all moving machinery parts including pump drive shaft assemblies.

7.7.1.17 **Valve Wrenches:** Gate keys required for turning station valves, including any alfalfa valves, shall be provided along with a wall bracket mounted inside the station for storage of the gate keys.

7.7.1.18 **Hose Bib:** Provide a ½” hose bib within the pump room for cleaning of equipment. Backflow protection for the hose bib shall be separate from the 2-inch fire hose bib adjacent to the wet well, but may be part of the emergency eyewash or restroom backflow protection, if required.

7.7.2 **EQUIPMENT REMOVAL**

7.7.2.1 **Hoist Clearance:** Ensure adequate horizontal and vertical clearance between overhead crane hoists and other installed equipment to allow lifting and moving motors and pump equipment to the station doors via the crane rail. Motor room crane rails shall extend beyond double entry doors to allow removal of equipment from the dry well building. Rubber enclosure flaps shall be installed where the crane rail exits through the door cutout.

7.7.2.2 **Extended Shaft Pump Equipment Hoisting:** In the pump room, for removal/reinstallation of pumps provide a wall mounted, rotating jib crane between each pair of installed pumps. This crane shall be equipped with hand chain hoists and shall allow lifting and moving pumps between the pump base and the floor. Also, provide an overhead crane rail with motorized hoist and trolley in the pump room for subsequently lifting and moving equipment across the pump room to a position below the equipment maintenance access hatch. Alternatively, where this jib crane installation cannot be accommodated due to space or piping limitations, provide lifting eye bolts in the ceiling between each installed pump and adjacent wall mounted eyebolts. Eyebolts shall be mechanically connected to the reinforcing bar with a structural insert. These will be used for installation of hand chain hoists for lifting and moving pumps vertically or horizontally between the pump base and the floor. If a rolling gantry crane is satisfactory, no other hoist is needed in the pump room. For this alternate installation, provide a heavy duty rolling ladder to be stored in the pump room for installation and movement of the mechanical chain hoists. Finally, install an overhead crane rail and equipment maintenance hatch in the grade level motor control center for removing equipment from the pump room and out of the station; same as the jib crane installation.

7.7.2.3 **Hoisting Submersible Pumps (Special Station Requirement):** For submersible pumps in a dry well application in the pump room, install an overhead crane rail hoist for lifting and moving equipment to the pump room access hatch for equipment removal. Also, install an overhead crane rail in the grade level motor control center room for removing equipment from the pump room and out of the station.

7.7.2.4 **Traveling Overhead Crane Rail Hoists:** For electrical spark hazard safety, traveling rail trolley hoists shall utilize extending power cords (i.e. instead of open bus type electrical power source) to supply power to the unit trolley as it moves along the crane rail.

7.7.2.5 **Equipment Hatches:** Equipment hatches and rail hoists shall readily allow removal or installation of equipment in the station. Access floor doors shall be H-20 load rated, single leaf type fitted with end chains, stainless steel hinges, stainless steel vertical spring in a closed tube, and shall be spring balanced doors requiring a maximum force of 40 lbs, Bilco Inc., or approved equal. For larger sized equipment, use double leaf for easy lifting.

7.7.3 **HAZARDOUS GAS DETECTION SENSORS**

7.7.3.1 **Methane/Explosive Gas Sensors and Alarms:** Methane/explosive gas sensors and alarms shall be provided in accordance with subsection 7.5.3.2 requirements.

7.7.3.2 **Access to Sensors:** Provide ladder with safety climb rail for access from motor or MCC room to sensors mounted above 5-feet in height on the wall.

7.7.3.3 **Hazardous Gas Warning Sign:** Locate the following warning sign in each area of the pump station: “Warning: Possible Hazardous Gas Conditions. Continuously Operate Portable Hazardous Gas Detection Equipment Inside Facility”.

7.7.4 **FINISHES AND STANDARDIZED PAINT SCHEMES AND LETTERING**

7.7.4.1 **Piping Color Scheme and Markers:** Identification of piping associated with equipment and other utility lines and identification devices for all hazardous chemicals storage and conveyance facilities shall comply with the Exposed Piping Identification Schedule of Specification Section 15030, Volume VI of the Clean Water Program Guidelines, and shall include the use of pipe markers that indicate the type of utility line and the flow direction. Table 7.7-1 shows the color identification scheme for piping.

TABLE 7.7-1

EXPOSED PIPING IDENTIFICATION SCHEDULE

<u>Fluid Abbreviation</u>	Function & Identification	Identification Color	Remarks Suggested Tnemec Color, or Approved Equal
CA	Compressed Air	Off-White	Barbados PA24
CS	Sodium Hydroxide (NaOH)	Yellow	Safety Yellow
EE	Engine Exhaust	Yellow	Safety Yellow
FA	Foul Air	Off-White	Barbados PA24
IA	Instrument Air	Off-White	Barbados PA24
PRW	Process Water, Industrial Water, Seal Water	Light Blue	Clear Sky EN17
PW	Potable Water	White	
RS	Raw Sewage	Grey	Grey IN05
SHC	Sodium Hypochlorite (NaOCl)	Yellow	Safety Yellow
Valves		See Remarks	Same color corresponding to fluid being carried
VD	Ventilation Ductwork	Off-White	Barbados PA24
NG	Natural Gas	Yellow	Safety Yellow

7.7.4.2 **Paint Scheme for Other Equipment:** The paint scheme for other equipment shall comply with Specification Section 15030 of Volume VI, City of San Diego Clean Water Program Guidelines. The types of equipment may include engines, generators, air compressors and their accessories, and hazardous chemicals storage for odor control systems. The paint scheme for equipment not included above shall be as directed by the Senior Civil Engineer. Table 7.7-2 is in compliance with Section 15030 of Volume VI, City of San Diego Clean Water Program Guidelines.

TABLE 7.7-2

**COLOR IDENTIFICATION SCHEDULE
FOR EQUIPMENT AND ASSOCIATED PIPING**

Equipment Type	Color
Pumps (service pumps) Piping	OSHA Safety Blue OSHA Safety Red
Air Compressor Compressed Air Pipe	Light Green with Dark Green Bands White
Drive Shaft Guard Cage	OSHA Safety Red
General Hazardous Equipment, Valves	OSHA Safety Red
Overhead Crane Rail/Lifting Hook	OSHA Safety Yellow With Black Striping
General Warning - Equipment	OSHA Safety Yellow
Outside Parking Post	OSHA Safety Yellow With Reflectors
Electrical Conduit	Dark Green
Generator	Manufacturer's Yellow

7.7.5 SUMP PUMPS

7.7.5.1 **Piping to Sump Pump:** Drain the dry well into a sump in the pump room. The sump shall be easily visible from the floor above. Do not drain upper pump station levels directly into the wet well (odor problems, and a flooded wet well will flood the station).

7.7.5.2 **Sump Pump Features:** Sump pumps shall be designed with the following features: Minimum solids passing capability of 2 inches; motor over-temperature and seal chamber moisture detection alarms; recessed vortex impeller or non-clog type impeller. Two pumps (one duty and one standby) shall be provided; and the pump control panel shall be located at the MCC level. Specify pumps with “heavy duty” rating (bearings and seals) suitable for pumping solids and grit that can operate without overheating in a partially submerged condition. The pump shall include the following features: lower shaft bearings, stainless steel shaft, double silicon carbide mechanical seals,

and oil-filled motor. The pump power leads shall plug into an electrical outlet for ease of replacement. Locate this outlet in an accessible area above flood level, but not less than 4 feet above the finished floor.

7.7.5.3 Sump Pump Discharge Piping Features: Piping installation shall be designed with the following features: sump opening shall be covered with FRP grating and 316L stainless steel frame opening; PVC discharge piping and fittings, a union at the connection to the PVC discharge piping (to allow pump removal for maintenance); cleanout tee fittings at elbows; swing check valves mounted in a horizontal position (to prevent jamming from sedimentation); and ball type PVC isolation valves on sump pump discharge piping. The sump pump discharge shall be routed into the wet well 2 feet above the elevation of the overflow pipe to the emergency storage tank.

7.7.6. FLOODED MCC LEVEL ALARM AND SWITCH

7.7.6.1 Electrical Power Shutoff on Major Flooding: For underground pump stations where the motor control center is below grade, a high water level float switch shall be located just below the MCC level. It shall lock out all power to the station, i.e. the main electrical service and emergency generator to prevent shock hazard and damage to electrical equipment from submergence while under load.

SECTION 7.8 WET WELL**7.8.1 INLET DESIGN**

7.8.1.1 **Inlet Pipe:** Design the wet well inlet sewer such that its invert is above the high water operating level. (Note: ensures unusual inlet sewer conditions do not exist that could cause odor problems to occur at upstream sewer lateral roof vents of buildings due to back up of odors from the station wet well). Provide a wall slope below for the inflow to flow down, rather than discharging vertically to the water surface. Locate the inlet so that inflow is evenly distributed to all the pump suctions. The inlet discharge shall be designed to minimize turbulence and odor generation and shall be designed in accordance with ANSI/HI 9.8 Pump Intake Design Standard for solid-bearing liquids.

7.8.1.2. **Inlet Sewer:** The inlet sewer shall be designed to minimize turbulence and odor generation. Design the line to avoid hydraulic jumps or other conditions that can result in sealing of the air flow space above the water flow line, which can create upstream odor conditions. Flow shall be sub-critical and normal depth for at least the final 10 feet before entering the wet well. Design shall include two flexible joints on the influent sewer within 5 feet or 2D of the wall penetration to allow for differential settlement. Do not allow inlet pipe to discharge directly on pump suction elbow. Use troughs if necessary, or direct flow away from suction.

7.8.1.3 **Influent Flow Meter (Special Station Requirement):** Major pump stations (5 MGD and above) shall have a flow measuring device on the incoming sewer, ADS Inc., or approved equal, if required for billing purposes. (Note: this is a separate requirement from the ultrasonic flow meter required on the discharge manifold of all stations).

7.8.1.4 **Spill Location:** The influent sewer and pump station spill locations shall be indicated on the design drawings (i.e., lowest upstream elevation or wet well cover elevation where backup spill will occur). Include M.S.L. elevation information for spill location.

7.8.2 HYDRAULIC DESIGN

7.8.2.1 **Standard Wet Well Configuration:** The standard configuration shall be to install the pump suction ell piping at a flat section of the wet well. This flat section shall have sufficient width for installation of the inclined bar rack, and an additional 2 feet minimum for personnel to stand on in front of the bar rack. Walls shall be sloped down to this floor portion.

- 7.8.2.2. **Suction Elbow:** The distance between the wet well floor and the turned down bell mouth suction inlet of diameter "D" shall be a maximum of D/2 and a minimum of D/4, but not less than 3 inches. Minimum submergence of the pump suction bell (the upper end defines the low flow level) shall be determined in accordance with ANSI/HI Section 9.8.7
- 7.8.2.3 **Self-Cleaning Wet Wells (Special Station Requirement):** Wet wells shall be designed in accordance with the Hydraulic Institute Section 9.8 Pump Intake Design Standard for trench type wet wells for solids-bearing liquids. Velocity at the pump intake bell shall not exceed 3.5 fps. Self-cleaning trench type wet wells shall be evaluated for use for pump stations equal to or greater than 3 mgd capacity. Separate overflow storage may be provided if sufficient storage volume cannot be provided in the wet well above the trench. Normal wet well operating level shall not exceed invert of inlet pipe. Design shall employ an electrically actuated inlet sluice gate for wet well level control during cleaning (when the wet well level is drawn down to the pump intake level). Note: This installation shall include non-submerged inlet, constant speed pumping, bar rack screening, and overflow storage if required. See Figures 7.8-1A, 7.8-1B and 7.8-1C for wet well arrangement.

7.8.3 TRASH RACK

- 7.8.3.1 **Trash Rack above Pump Suction:** Provide a trash rack constructed of 2-inch PVC pipe angled at 45° above the pump suction area. The trash rack openings shall be 2¾ inches clear with 2¾ inches clearance to the floor, and the horizontal support members of the rack shall be spaced at 18-inches. The sections of the trash rack shall be held with Type 316 stainless steel clips to allow removal by maintenance personnel for hand cleaning under the trash rack when the wet well is pumped down. Provide a minimum of 2 feet of flat floor in front of the bar rack for safe footing of personnel during rack maintenance.
- 7.8.3.2 **Large Pump Station Trash Rack/Screen (Special Station Requirement):** For wet wells in large stations (3 mgd), install the following bar rack/screen installation: The inlet sewer shall discharge onto a Type 316 stainless steel bar rack inclined at 45 degrees with 2¾-inch spaced bars to screen inflect (screen objects 3-inches and larger) into the wet well. The bar rack shall connect at its upper end to a bar screen platform with grating openings of 2¾ inches by 4 inches to screen objects larger than 3 inches in diameter. The bar rack/bar screen platform shall extend across the entire horizontal area of the wet well. All supporting beams, and angles to support the bar screen assembly shall be Type 316 stainless steel. All anchor bolts shall be Type 316 stainless steel. A safety railing constructed of Type 316 stainless steel shall be installed at the junction of the bar screen platform and bar rack to protect personnel standing on the bar screen platform cleaning the bar rack from falling onto the bar rack. A removable panel shall be installed in the bar

screen platform below a 36-inch manhole cover (described in subsection 7.8.8.1) to allow access for cleaning the bottom of the wet well with vector truck suction equipment. The clips securing the bar screen shall be Type 316 stainless steel.

7.8.3.3 **Self-Cleaning Wet Wells (Special Station Requirement):** For self-cleaning wet wells, described in subsection 7.8.2.3, bar rack shall be constructed of 2-inch Schedule 80 PVC with 2-inch clear openings and shall rest on the upper portion of the inlet ramp. A 36-inch manhole shall be located directly above the bar rack to allow access from above for cleaning screening accumulations with vector truck suction equipment.

7.8.3.4 **Mechanical Screens: (Special Station Requirements):** Where a mechanical screen is required, provide a moving rake type screen (“Climber” Screen by Infilco-Degremont, FMC or approved equal) in accordance with the Clean Water Program Design Guidelines, Appendix D, Chapter D14. Discharge directly to a screenings washer/compactor and then convey the washed/compacted screenings to a roll-off bin for handling off-site.

7.8.4 **STORAGE VOLUME REQUIREMENTS**

7.8.4.1 **Operational, Two-Hour, and Six-Hour Emergency Storage Volume Requirements:** Refer to subsections 7.2.6.7 and 7.2.7 for emergency storage volume requirements.

7.8.4.2 **Design Features for Emergency Overflow Storage Wet Well:** Separate the working volume storage (volume of sewage pumped per pumping on/off cycle) of the pump station from the two-hour and/or six hour overflow storage. To separate the working volume from the six hour overflow storage volume, provide an overflow line with swing flapper valve to prevent wet well gas from entering overflow storage volume, and a gate valve for drainage back into the working volume for pumping down the overflow storage wet well after the overflow event. Provide two (2) roof access openings for both the operating wet well and emergency storage wet well for safety and maintenance operations.

7.8.4.3 **Design Features for Emergency Overflow Storage Tank:** Alternatively, the emergency storage can be in a separate storage tank. The overflow line to the tank shall be located in a valve box and equipped with a swing flapper valve that will open to allow flow into the storage tank, but will prevent wet well gas from entering the overflow tank. A separate valved drain line to the wet well shall be installed. The tank bottom shall be sloped to provide overall drainage from the floor back to the wet well. Provide two (2) access openings for the tank for safety and maintenance operations.

7.8.4.4 **Passive Overflow:** For low lift pump stations, in lieu of emergency storage, design a passive bypass flow line from the wet well to the discharge trunk sewer (TS) if a high wet well water level can rise above the discharge TS elevation without backup/flooding in the inlet line.

7.8.5 CORROSION PROTECTION

7.8.5.1 **T-Lock Lining:** Wet well walls and ceiling (start at base of wall) shall be lined with T-lock PVC. Pipe penetrations shall be sealed with a bonding agent and T-lock. The floor of the wet well shall be coated with a two part epoxy primer and 100 mil polyethylene coating system, Sancon, Inc., or approved equal. Specify that the installer shall be licensed for this work by the manufacturer. Also, specify that the high voltage holiday (spark testing) inspection for this work shall be accomplished per the most rigorous GREENBOOK requirements (i.e., highest test equipment spark voltage). The coating and PVC lining shall be free of pinholes as confirmed by the spark testing.

7.8.5.2 **Pipe and Fittings Coatings and Linings:** All ferrous piping shall be coated and lined according to the requirements of Chapter 6, Section 6.2.

7.8.5.3 **Fasteners:** All fasteners in the wet well for piping and anchor bolts shall be Type 316 stainless steel.

7.8.6 ELECTRICAL EQUIPMENT INSTALLATION

7.8.6.1 **Level Control:** The level control shall be as indicated in Subsection 7.5.3.4. The installation detail for the transducer, if used, shall be as shown on the associated standard electrical/control drawings in this Design Guide, **ATTACHMENT 3**. The ultrasonic level transducer, if used, shall be located in a position easily reached from the exterior of the wet well but shall not impede access to the wet well.

7.8.6.2 **Explosion Proof Installation:** All electrical conduit and wiring into the wet well shall be NEMA 6P submergence rated. All conduit penetrations into the wet well shall have NEMA 4X explosion proof seal-off fittings. No junction boxes or covers shall be installed in the wet well.

7.8.7 WET WELL VENTILATION AND ODOR CONTROL

7.8.7.1 **Ventilation, Odor Control:** Refer to Design Guide Subsection 7.6.5 for specific requirements regarding wet well ventilation and odor control.

7.8.8 WET WELL ACCESS

All wet well access shall be located outside of the dry well.

- 7.8.8.1 **Standard Access:** Install two 36-inch diameter manhole covers (with 24-inch diameter center access cover) on the wet well roof. Locate at opposite ends and above the flat portion of the wet well (located in front of the inclined bar rack over the pump suction lines). One access is for personnel and the second for vacor cleaning and equipment removal. All access to the wet well shall be by safety tripod and harness. Therefore, no ladders or manhole steps shall be provided in the wet well.
- 7.8.8.2 **Alfalfa Valves (Special Station Requirement):** To prevent spilling from the wet well or exit of odors and to provide access, the wet well shall be fitted with two, 36-inch diameter, rubber-gasketed, locking alfalfa valve covers, each located as described in subsection 7.8.8.1 for manholes. The inner surface of the valves and frames shall be coated with fusion bond epoxy for corrosion protection. The threaded stems and threaded supports shall be low-phosphor bronze. The alfalfa valves shall have a removable arch support with locking eccentric latches to allow unobstructed access into the opening. Each valve shall have a rubber gasket for a gas tight seal.

SECTION 7.9 FORCE MAINS**7.9.1 GENERAL REQUIREMENTS**

- 7.9.1.1 **Force Main Velocity:** The minimum discharge velocity in the force main shall be 4 fps at design capacity in order to achieve cleansing velocities and a maximum of 8 fps to avoid excessive friction head losses.
- 7.9.1.2 **Dual Force Mains:** All pump stations shall be equipped with dual force mains. Each force main shall include the following: isolation valves, emergency pump connection (see subsection 7.9.2.4), and valved drainage line into the wet well (located inside the dry well). This shall allow use of either force main should the other line require draining and repair.
- 7.9.1.3 **PVC Pressure Pipe:** Green PVC pipe is the preferred material for force mains. Force main fittings and appurtenances shall be ductile or cast iron. Analyze pipeline stresses to PVC that will occur with pressure on/off cycles and surge pressures to ensure the PVC will operate over the working life of the pump station (50 years). Use an “E” in the design of PVC pipe that is appropriate for PVC pipe at the end of its planned design life. However, the minimum pressure class for all stations, regardless of total dynamic head requirements, shall be at least Class 200.
- 7.9.1.4 **Ductile Iron Pipe (Special Station Requirement):** Lined and green color coated ductile iron pipe may be specified for force mains in special cases, with prior approval by the Senior Civil Engineer. This may include high lift stations (total discharge head greater than 100 psi) where the initial length of the force main to the property line (where access for repair is typically difficult due to the depth of pipe) may be constructed of ductile iron. Considerations must be made for corrosion monitoring and protection (see Subsection 6.2.3).
- 7.9.1.5 **Force Main Isolation Valves:** Install isolation valves on each force main either inside the dry well (located near the wall penetration) or outside the station, within the fenced-in area (located upstream of the emergency pump connections).
- 7.9.1.6 **Flex Couplings at Pump Station Wall:** Install dual flexible couplings, dresser couplings or ball and socket type fittings, outside the station on the force main to allow for differential settlement.
- 7.9.1.7 **Cathodic Protection:** Cathodic protection requirements for buried metallic piping and fittings shall be determined by the results of the Pre-Design Survey outlined in Chapter 6, Section 6.3.

Refer to Chapter 6 for other detailed specific corrosion protection requirements.

- 7.9.1.8 **Thrust Blocks:** Provide thrust blocks at all bends on the force main. In constructing the required dual force mains, ensure that at bends, each force main thrust block is installed against undisturbed soil. Vertical thrust restraining clamps on siphon high points shall be specified as required to restrain the pipe. No vertical thrust blocks are allowed.
- 7.9.1.9 **Restrained Buried Pipe Joints:** Specify restrained mechanical joints as required in special areas (steep sloped areas, fill areas without sufficient resistance to thrust) to ensure security of joints. Indicate locations of restrained joints on the drawings. Fittings that provide joint thrust restraint and/or joint rotation shall be provided as required, EBAA IRON, “Megalug” or “Flexextend” respectively.
- 7.9.1.10 **Cut-Off Walls:** Cut-off walls, per SDRSD SDS-115, shall be used as required for piping on steep slopes. Provide vertical thrust restraint and/or joint rotation fittings, e.g. for subsidence allowance, as required.
- 7.9.1.11 **Use of 45-Degree Elbow Fittings:** To reduce the potential for stoppages where a 90-degree change of direction in the force main is required, show and specify two 45-degree elbows or a horizontal curve instead of a 90-degree elbow.
- 7.9.1.12 **Force Main Drains: (Special Station Requirement):** If low points exist in the force main, install valved drains at these points to allow localized draining of the force main to suitable locations to facilitate repairs.
- 7.9.1.13 **Force Main Separation and Pipe Joint Stagger:** Construct the dual force mains in separate trenches with a minimum 5 feet separation between their outer surfaces. Plans should contain a notation for staggering the pipe joints to lessen potential undermining if a leak occurs in either force main.
- 7.9.1.14 **Use of Combination Air Valves:** Where at all possible, force mains shall be designed with a continuous uphill slope without high points so that air-release valves are not required on the force main. If the force main cannot be designed this way, provide two (2) redundant air-release valves at high points where there are siphons or at discontinuities in grade. Combination air-release valves (i.e., two body valves to allow air release during filling, air release for trapped air under pressure, and air entry (vacuum relief) during pipe emptying,) shall be installed inside a vault to allow access to the valves for maintenance. All piping and valve appurtenances within the vault shall be Type 316 stainless steel. Discharge from the air vent shall be piped to the nearest sewer manhole. If a manhole is not located within suitable distance, provide additional space in the air valve vault for potential future installation of a charcoal canister for odor control of the air valve discharge, if needed.

7.9.2 ISOLATION VALVES AND EMERGENCY PUMPING CONNECTION

7.9.2.1 **Solid Wedge Type Valves:** For buried applications, provide "solid wedge" type gate valves for sewage applications with the following features: type 316 stainless steel stem, gate, and seat inserts, stainless steel fasteners in wetted areas, and fusion bond epoxy on all ferrous parts. Valves shall be designed for buried service with water tight bonnet and buried service gear operator.

7.9.2.2 **Isolation Valve Location:** Install isolation valves inside the station fenced-in area. Where difficult soil conditions exist or where valves may not be easily accessible, install the valves in a vault for easy access. Isolation valves shall be installed on each force main both inside the dry well (located near the wall penetration) and outside the station within the fenced-in area (located upstream of the emergency pump connections).

7.9.2.3 **Force Main Drain Lines:** Install valved drain lines on each discharge line manifold in the pump room for draining each force main individually back into the wet well (use during maintenance to repair leaks in one force main while operating the second force main).

7.9.2.4 **Emergency Pumping Connections:** An emergency pump discharge connection shall be built into both force mains. This assembly shall be designed as follows: locate a "wye" fitting on each force main downstream of the flex couplings and force main isolation valve. Install the isolation valve and blind flange in a vault (use Type 316 stainless steel bolting for corrosion resistance). Avoid installing the vault in areas subject to traffic. Size each vault large enough for connections of large diameter flexible discharge hoses from emergency pumps. Orient the blind flange at 45 degrees up from horizontal for ease of connecting hoses in the vault. The minimum allowable diameter size for the connection is 6 inches. (Note: this emergency connection can also be used as a cleanout.)

7.9.2.5 **Valving Diagram:** Specify a wall mounted plastic laminated diagram in the station that shows the location(s) of the dual force mains and the force main valving on the site. This sign shall also note the maintenance schedule for exercising and testing the force main isolation valves.

7.9.3 DISCHARGE MANHOLE

7.9.3.1 **Discharge Manhole:** Each force main shall discharge into a separate manhole (PVC lined) with gravity discharge into a gravity sewer. Install offset fittings and/or long radius elbows on the force main discharge as required in order to enter the manhole at the required height and in the direction of flow in the gravity sewer. The force main discharge shall be above the flow line of the gravity sewer to prevent siphoning back to the wet

well. Gravity discharge into the gravity sewer shall have laminar flow prior to entering the manhole.

7.9.4 **ODOR CONTROL**

7.9.4.1 **Chemical Odor Control:** Long force mains and/or excessive detention times in the wet well and/or a long transport in the drainage basin can create odor problems, accelerated corrosion and hazardous gases in downstream discharge sewers. It is desirable that a negative pressure be maintained at the discharge point to prevent gases from entering laterals and discharging through plumbing system vents. This may require a vent back to the pump station wet well or a gravity canister system depending on the volume of gas displaced relative to the current pipe gas pressure and the receiving pipe diameter. If required due to downstream sewer conditions, provide an odor control system which can include chemical injection into the wet well such as calcium nitrate or other approved chemicals.

SECTION 7.10 STATION BUILDINGS AND SITE REQUIREMENTS**7.10.1 STRUCTURAL CONCRETE**

- 7.10.1.1 **Reinforced Concrete:** Specify a shrinkage control concrete mix suitable for wastewater storage structures. The concrete shall include a retarding-densifier admixture for increased flexural strength and shrinkage control (as outlined in ASTM C 157). Structural concrete shall typically have a minimum 28-day compressive strength of 4,000 psi. Specify concrete mix with low specific conductivity (sulfate and chloride concentrations) to minimize the potential for reinforcing bar corrosion.
- 7.10.1.2 **Structure Waterproofing and Moisture Barriers:** Specify waterproofing on the outside buried walls of the station structure. The following methods of water proofing are acceptable: coal tar epoxy coating, bituminous sheeting, polyethylene membrane, polypropylene bentonite or crystalline cementitious chemical treatment. A plastic vapor barrier shall be installed under the pump station and special care shall be taken during construction to avoid puncturing the barrier.
- 7.10.1.3 **Wall Penetrations:** Seals at piping and conduit wall penetrations into the station shall be designed with non-shrink grout (with water stops) if below grade, or mechanical rubber seals if above grade, and be water pressure tight.
- 7.10.1.4 **Concrete Form Taper Ties:** Concrete form taper ties shall be provided with integral water stops and, after removal of forms, shall be grouted water tight with epoxy grout.
- 7.10.1.5 **Waterstops:** Specify waterstops at all cold concrete construction joints. Waterstops shall be as specified in the City of San Diego Clean Water Program Guidelines, Specification Section 03290.
- 7.10.1.6 **Prohibition of Package Plant Type Facilities:** All new pumping stations shall be constructed in reinforced concrete with separate wet well and dry well type layout. Package plant type installations, such as used in buried fiberglass reinforced polyester (FRP) enclosures or steel enclosures are prohibited.
- 7.10.1.7 **Floor Penetrations:** For all piping and conduit penetrations between accessible floors, provide PVC sleeves at least 1-inch larger than the outside diameter of the carrier. The top of the sleeves shall be a minimum of 1-inch above the finished floor elevation. The purpose of the sleeves is to allow for future replacement without damaging the structural components of the floor.

7.10.2 **BUILDING CONSTRUCTION**

7.10.2.1 **Typical Construction:** The typical pump station shall be cement mortar brick construction with tile type roof. Facility architecture shall be compatible with local planning standards.

7.10.3 **BUILDING FEATURES**

7.10.3.1 **Intrusion Security:** Provide an alarm against unauthorized entry to the pump station (refer to the Telemetry Section). An external monitoring camera may be required at the discretion of the Public Utilities Department.

7.10.3.2 **Outside Door Fittings and Locks:** All outside doors and frames shall be corrosion and vandal resistant, with stainless steel security fittings and locks. Specify locks with interchangeable Type 316 stainless steel cylinders that can be keyed to the City standard locks manufactured by Best, Inc., or to the SDG&E standard lock as required. The Contractor shall be directed to contact the City for requirements to install City standard locks and cylinders. Specify that all keys be stamped “Do Not Duplicate”, and specify provision of five (5) complete sets of all required station keys. Station door locks shall allow securing the door from the inside to provide security for personnel while working inside.

7.10.3.3 **Bulletin Board and Reference Shelf:** Specify that the Contractor shall install in the pump room a 3 feet x 4 feet bulletin board for posting operating information, and an adjacent shelf to hold Operations and Maintenance Reference data.

7.10.3.4 **Building Lighting:** Outside building lighting shall be provided at the station door.

7.10.3.5 **Site Lighting:** Provide outside site lighting with photocell and manual on/off control.

7.10.4 **SITE, ACCESS, AND PAVING**

7.10.4.1 **Fee Title Property:** The City shall be granted Fee Title ownership of all sites.

7.10.4.2 **Site Paving:** Vehicular access roads to pump stations shall be paved and a minimum of 24 feet wide at a 15 percent maximum slope. Pave station areas to the maximum extent in order to reduce landscape requirements. All site paving shall be designed for DOT H-20 loading.

- 7.10.4.3 **Site Fencing and Walls:** The pump station site shall be enclosed by a fence. Typically provide a six-foot high PVC-coated chain link fence around the site, with webbing as required by the City of San Diego Standard Drawing SDM-112. Alternately, if required by area architectural requirements, design a site wall.
- 7.10.4.4 **Gates:** All sites shall be provided with a City locked gate. No private gates are permitted across access roads.
- 7.10.4.5 **Positioning Maintenance Vehicles:** Access at the station shall allow positioning a crane truck of the size required for removal of station equipment. Access shall also be provided for the positioning of a vactor truck to clean the wet well, where manual cleaning is required. The site shall also include sufficient parking and turnaround space for two, 1-ton maintenance trucks. Truck access shall be provided at the locations of the emergency discharge connections and all cleanouts.
- 7.10.4.6 **Vehicle Turnaround Radius:** For the largest maintenance trucks, provide a minimum turning diameter of 100 feet for accessing the site.
- 7.10.4.7 **Parking over Wet Well Pipe Connections:** Locating truck access over the inlet and discharge piping penetrations into the station shall be avoided to eliminate pipe shear loadings at these locations.
- 7.10.4.8 **Flood Plain Elevation:** Pump station pad elevations shall be designed to be a minimum of 2 feet above the 100-year flood elevation. Flood plain information shall be indicated on the design drawings.
- 7.10.5 **WATER METER AND BACKFLOW PROTECTION**
- 7.10.5.1 **Water Meter Costs and Backflow Protection Device:** A drawing note and project specifications shall require the Contractor to obtain the water meter permit for a 2-inch meter and reduced pressure (RP) backflow prevention device, and pay all installation costs for the meter to be installed by the City. The 2-inch RP can be installed by the Contractor utilizing RP devices listed on the Water Department's *Approved Materials List*. (Note: Due to capacity charges for new meters, this meter connection now costs approximately \$15,000. **This cost shall be listed in the construction bid as a line item cost.**
- 7.10.5.2 **Water Meter Ownership:** Specify that the water meter shall be in the name of the Contractor and that all meter service charges shall be paid by the Contractor until the service is transferred to Wastewater Collection Division at the time the Facility is accepted by the City.

- 7.10.5.3 **Hose Bib and Backflow Protection:** Design a 2-inch fire hose bib outside, adjacent to the wet well. The connection to the hose bib shall be separately protected with a 2-inch reduced pressure backflow device if a bathroom or emergency eyewash is installed at the building (see subsections 7.10.5.4 and 7.10.5.5). Locate parking posts around the hose bib and backflow protection device to protect against traffic.
- 7.10.5.4 **Emergency Eyewash (Special Station Requirement):** Where odor control installations with hazardous chemicals are included, provide an emergency eyewash/shower station (for accidental chemical burns that may occur during maintenance).
- 7.10.5.5 **Restroom (Special Station Requirement):** If the station includes a restroom facility, a second 2-inch reduced pressure backflow device shall be provided at the hose bib located next to the wet well. This second RP device shall protect the upstream connection to the restroom from potential contamination from the hose bib. Locate parking posts as required around the hose bib and RP to protect from traffic.
- 7.10.6 **LANDSCAPING**
- 7.10.6.1 **City Standard:** All pump stations shall be landscaped in compliance with the City of San Diego Landscape Technical Manual in a manner acceptable to PUD and the community concerned. The landscaping shall be similar to the adjacent area. In addition, the landscaping shall be of drought tolerant species that grow easily in a low maintenance environment, i.e., grow to a plant of suitable natural size and shape without pruning and are disease and insect resistant. The irrigation and landscaping shall be designed in accordance with the City of San Diego Landscape Technical Manual utilizing materials on the Park and Recreation Department's Approved List and shall comply with the City of San Diego Standard Drawings, the Standard Specifications for Public Works Construction (SSPWC, also known as The GREENBOOK), and its Regional and City of San Diego Supplement Amendments including the Clean Water Program Supplement Amendments to The GREENBOOK.
- 7.10.6.2 **Xeriscaping:** Landscaped areas in the pump station shall have low maintenance, drought resistant, low irrigation "xeriscaping" type landscaping. Above grade piping shall be PVC.
- 7.10.6.3 **Backflow Protection on Irrigation Piping:** The irrigation system piping connection shall be protected by a separate 1-inch reduced pressure backflow assembly (i.e., additional to the 2-inch RP backflow protection device at the station water meter).

SECTION 7.11 CONSTRUCTION MANAGEMENT AND OPERATIONAL TESTING SPECIFICATIONS**7.11.1 GENERAL**

The DESIGN ENGINEER shall provide appropriate information in the Design Plans and Specifications to describe the following requirements:

7.11.2 COORDINATION OF NEW CONSTRUCTION WITH EXISTING STATION OPERATION

7.11.2.1 Salvage Note on Drawings: The Contractor shall remove equipment to be salvaged and deliver to location specified by the owner. The Contractor shall list the items to be salvaged when determined by the City.

7.11.2.2 Temporary Bypass Pumping (Special Station Requirement): The Contractor shall install and operate a temporary bypass pumping system as required to maintain pumping operations at existing facilities during construction of the new station. This system shall include an automated telemetry system to dial out to the Contractor for repair response and also to the City in the event of failure conditions. The Contractor shall submit to the City for approval a complete Bypass Plan, including detailed drawings and pump curves, and a Sewage Spill Prevention and Response Plan.

7.11.2.3 Sequence of Construction: Where bypass pumping of the existing station and/or for tie-in connection of new facilities is required, the DESIGN ENGINEER shall provide a general recommended sequence of construction on the plans and in the General Provisions to describe the required construction sequence, including bypass pumping.

7.11.3 FACILITY TESTING

7.11.3.1 General Requirements: The following describes the general responsibilities of the Design Consultant and the Contractor:

7.11.3.1.1 Design Engineer Responsibilities: The DESIGN ENGINEER shall prepare specification Section 01660 of the Clean Water Program Guidelines (CWP) describing facility testing requirements as discussed below. This specification will describe the phases of testing and requirements of the Contractor in accomplishing this testing and maintaining required test records and documentation. This description shall include a detailed listing in tabular form of all the specific test procedures to be accomplished by the Contractor for each phase of the test sequence. Section 01660 shall include a schedule of operational tests that will demonstrate the proper operation of all equipment at

the station. The proper operation of all pump station mechanical equipment, electrical controls, emergency power operations and control warning displays shall be demonstrated by the Contractor. Simulated failure conditions shall be initiated as required to demonstrate proper warning displays.

- 7.11.3.1.2 **Contractor Responsibilities:** The Contractor shall implement the requirements of specification Section 01660, including demonstration and testing of all equipment as described in the operational test procedures, preparation and completion of required equipment test report forms, test procedures verification checklists, and other documentation to be provided by the Contractor.
- 7.11.3.1.3 **“Master Test Plan”:** Based on the Section 01660 requirements, the Contractor shall prepare a “Master Test Plan” for approval by the City prior to the start of testing. This plan shall be a bound, step by step compilation of the specific tests to be performed in the facility test sequence and the sample forms to be submitted documenting the results of the tests and test information. During the step-by-step testing, these forms will require signing off by the City representative prior to continuation of the test sequence. No test sequence shall commence or continue until all preceding tests have been successfully completed and signed-off by the City.
- 7.11.3.1.4 **Contractor Test Coordinator:** The Contractor shall designate a Test Coordinator responsible for accomplishing the required testing. All testing work shall be accomplished by a skilled team of specialists under the direction of the Test Coordinator.
- 7.11.3.1.5 **Scheduling of Facility Tests:** The Contractor shall schedule and coordinate all phases of the facility tests and demonstrations with City representatives.
- 7.11.3.1.6 **Testing Costs:** The DESIGN ENGINEER shall provide a general note in the contract documents specifying that the Contractor is responsible for all costs including power, fuel, potable water, testing/training specialists, and other testing costs associated with the facility tests until such time that the station is accepted by the City.
- 7.11.3.1.7 **Coordination with Other Specification Sections:** Section 01660 shall be a compilation of all facility and equipment testing requirements. It shall be coordinated with specific equipment testing requirements specified in Part 3 of the equipment specification sections.
- 7.11.3.2 **Summary of Master Test Plan:** Section 01660 of the project specifications shall describe the requirements of the facility test sequence. This shall incorporate the following sequential testing phases:

- 7.11.3.2.1 **Factory Testing:** This shall include testing and reports on the following major equipment and other equipment as required: pumps (certified pump test curves), motors, switchgear, emergency generators, motors, drive shaft units, and variable frequency drive units. The factory testing of the pumps shall be witnessed by the City's designated representative for pumps 100 horsepower or larger.
- 7.11.3.2.2 **Functional Checkouts and Installation Certification:** After all construction is completed, the Contractor shall submit a completed "Manufacturer's Installation Certification" form for each major equipment item certifying by the manufacturer's authorized representative that the equipment has been properly installed, aligned, and functionally checked out and is ready for pre-operational and start-up testing. Certification forms shall be submitted for all pumps, motors, extended drive shafts, variable speed drives, emergency generators, electrical switchgear, HVAC equipment, and odor control fans. Documentation demonstrating proper installation of any natural gas or diesel fuel system also shall be submitted. Forms demonstrating successful testing of the switchgear, motor control center, conductor installation, grounding system resistance, control system loops, circuit breakers and motor starters also shall be submitted.
- 7.11.3.2.3 **Pre-Operational and Start-Up Testing:** This shall include testing and reports on the following and other equipment as required: switchgear and MCC, VFD unit (including testing for harmonic distortion), control system operation, pumping units (including vibration testing on installed pump/motor/drive shaft unit to ensure no unusual vibration/harmonics within Hydraulic Institute limits), alignment testing, thermal testing, piping pressure and leakage testing, gate valves, ventilation system, equipment noise testing, generator run test (four hours under full load utilizing a portable load resistance bank), equipment hoists (OSHA Certification), and hazardous gas detection system. Failure conditions shall be simulated as required to demonstrate proper control operations, warning displays and SCADA system communications. The Pre-Operational testing shall utilize potable or reclaimed water (to be re-circulated to the wet well) for preliminary mechanical and electrical/control equipment operation. A performance test for the pumps shall be conducted to demonstrate conformance to the design.
- 7.11.3.2.4 **HVAC Testing:** The station ventilation systems shall be tested and acceptable certified performance test results shall be submitted prior to acceptance of the station.
- 7.11.3.2.5 **Operational Test:** After the Contractor has completed the pre-operational testing, and submitted the equipment certifications described above, the operational testing shall be scheduled. This shall demonstrate pump station operation on automatic control without equipment or control failure and with sewage tie-in. The pump station mechanical equipment, electrical/control systems, and emergency power equipment shall operate without failure during

the Operational Test. The contractor shall operate and monitor the station for five (5) consecutive days. If any failure or function outside the design parameter occurs, the contractor shall correct the deficiencies and the Operational Test shall be repeated.

7.11.3.2.6 **Commissioning:** After all the operational testing and required Master Test Plan documentation is completed and approved by the City, the Contractor shall make final adjustments to all equipment to ensure proper operation. The City will then accept operational responsibility of the facility. Following completion of all punch list items, facility acceptance by the City and filing of Notice of Completion can be initiated (refer below).

7.11.4 OPERATIONS AND MAINTENANCE MANUAL

7.11.4.1 **Number of Copies:** Provide four hard copies and one electronic copy on CD of the O & M manual to the City. All required information shall be provided in labeled and bound manuals.

7.11.4.2 **Warranty Address:** Ensure that the City Internal Order Number and the name/address of the pump station is noted on the manuals.

7.11.4.3 **O&M Contents:** The project specifications shall require the Contractor to include the following information in the O & M manual:

7.11.4.3.1 **Consolidated Summary:** Consolidated summary of required routine scheduled maintenance for all station equipment shall be provided along with references to the location within the manual where detailed information may be found (provided by the Contractor).

7.11.4.3.2 **Automatic Controls Summary:** Summary description of operation of station automatic controls (provided by the DESIGN ENGINEER) as incorporated in project specifications under "controls".

7.11.4.3.3 **As-Built Drawings of Electrical/Controls:** "As-built" drawings of electrical controls and all electrical equipment interconnection diagrams (the DESIGN ENGINEER shall review/check for accuracy the Contractor submitted electrical/control system as-built drawings and diagrams).

7.11.4.3.4 **Manufacturers' Certificates:** Installed equipment manufacturers' certifications.

7.11.4.3.5 **Equipment Specifications and Detailed O&M Information:** Equipment specifications and detailed manufacturers' maintenance and operation information on all equipment installed in the station (provided by the Contractor).

7.11.4.3.6 **Warranty Forms:** Completed manufacturers' warranty forms and information provided by the Contractor. (Refer to 7.11.6 for more information on warranty requirements).

7.11.4.3.7 **Table of Contents:** Table of Contents of material found in O & M manual.

7.11.4.3.8 **Certified Pump Test Curves:** A factory certified pump test curve for the actual pumping units (including motors) installed at the station.

7.11.5 FACILITY ACCEPTANCE BY THE CITY

7.11.5.1 **Recommendation for Acceptance by Owner:** After completion of the operational testing and commissioning, the substantial completion of all inspection punch list items, and receipt of all required submittals including the O & M Manuals and as-built drawings, the Wastewater Collection Division will submit a written memorandum via the Project Manager to the CONSTRUCTION MANAGER recommending that the City issue a Notice of Completion for the station.

7.11.5.2 **Acceptance of Operational Responsibility:** Following commissioning of the facility, the Wastewater Collection Division will accept operational responsibility for the station.

7.11.5.3 **Transfer of Utility Billings:** The Contractor shall submit the SDG&E utility billing and other utility billings to Wastewater Collection Division in order to transfer billings to the City. The effective date of the transfer shall be the date of the memorandum from the Wastewater Collection Division recommending acceptance. The DESIGN ENGINEER shall provide a general note in the design drawings discussing this timing for transfer of utility billings.

7.11.6 WARRANTY

7.11.6.1 **Start of Warranty:** Warranty dates shall commence on the date of the memorandum recommending acceptance in Subsection 7.11.5.1.

7.11.6.2 **One-Year Warranty (for overall facility):** The facility improvements overall will have a one-year full parts and service warranty period.

7.11.6.3 **Two-Year Warranty (for Major Equipment):** Major equipment including motors, wastewater pumps, VFD units (if installed) and the emergency generator shall be provided with a two-year manufacturer's warranty.

7.11.6.4 **Extended Warranty:** Should a facility be constructed by a private development, and not required to be immediately placed in service due to the

lack of subdivision occupancy, the facility overall one-year warranty period shall commence when substantial occupancy occurs. Until that time, after commissioning, the City shall regularly inspect and maintain the facility. However, the Developer shall be responsible for repair of any vandalism and warranty repairs until the end of the extended warranty period.

7.11.6.5 **Warranty Service:** The Contractor and/or equipment vendor (manufacturer's warranty) shall commence all required warranty repairs within 24 hours of notification by the City. Vendors for all major critical equipment (pumps, motors, motor control centers, VFD's, control panels, hazard warning systems, emergency generators, automatic transfer switches) shall have the capability of arriving on site with equipment and personnel for emergency repairs within four hours of notification by the City.

7.11.6.6 **Warranty Ownership:** Manufacturer's warranty documentation shall name both the Contractor and the City of San Diego as the holder of the Warranty.

7.11.7 **FACILITY TRAINING**

The Contractor shall provide, by factory trained representatives, a minimum of 16 hours training of City personnel in the operation of the station. This training shall emphasize theory of operation and maintenance of electrical controls, pumps, motors, generators, and other major equipment. This training can occur in conjunction with the facility test sequence, as appropriate.

7.11.8 **KEYING SYSTEM**

7.11.8.1 **City Standard Locks:** Following City acceptance, The Contractor shall key facility locks with the City standard SPA-1 lock manufactured by Best Inc. Also, provide the SDG&E standard lock, where required.

7.11.8.2 **Number of Key Sets:** The Contractor shall provide FIVE (5) sets of keys to all locked doors, enclosures, and equipment in the station at acceptance of the station by the City.

INDEX

A

Abandonment, 2.5.15, 2.5.16(e), 2.7.5.1, Table 2-8, 3.3.2, 5.1, 5.2, 5.3
Access, vehicular, see Vehicular Access
Access Hatches for Pump Stations, 7.7.1.4, 7.7.1.11, 7.7.2.5, 7.8.8.1
ACCESS ROADS, 1.2.1.3, 1.2.3, 3.2.1.3, 3.2.2.7, 3.2.3
 dead end, 3.2.3.1
 in environmentally sensitive lands, 1.2.3, 3.2.3.4, Exhibit 3-1, Exhibit 3-2
 in parklands, 3.2.2.6, 3.2.3.3
 in residential side yards, 3.2.3.2
 non-contiguous, 3.2.1.3
 pump station, 7.10.4
 requirements, 3.2.3, 3.2.3.1, 3.2.4.3
AGREEMENT,
 abandonment, 5.2, 5.3
 EMRA, 2.5.1(b), 2.5.12 (c), 2.5.13, 2.8.4, 3.3.2, 3.3.3.4, 4.2.1
Air Release Valves, 7.4.7, 7.9.1.14
Alignment of Sewers, 1.2.1, 2.2.5, 3.2.1.1
Alleys, 1.2.1.3, 1.2.1.4, 2.2.5.6, 2.2.5.7
Alternate Power for Pump Stations, 7.5.5, 7.6.4

B

Backwater Devices, 2.5.6, 7.10.5
Bedding, 2.4, 2.5.5
BRIDGES, Chapter 4
 access vaults in, 4.3.1.8, 4.3.3
 casings in, 4.3.1.4, 4.3.1.8, 4.4.2, 4.4.4.3, 4.6
 closed cell (box girder), 4.3.1.5, 4.3.2, 4.3.3, 4.4.2
 design of mains in, 4.3.1.1, 4.3.1.2, 4.3.1.3, 4.3.2, 4.3.4, 4.6
 differential movement, 4.3.4, 4.4.4.
 drainage in, 4.4.2, 4.5
 force main isolation valves in, 4.3.1.7
 future expansion in, 4.3.1.4
 joints in, 4.4.3, 4.4.4, see *also* JOINTS
 location of mains in, 4.3.1.1, 4.3.2, Figures 4-1, 4-2, 4-3, 4-4
 manhole requirements in, 4.3.1.6
 open girder, 4.3.3
 permits, 4.2
 pipe supports in, 4.5, Figures 4-6, 4-7, 4-8
 slab type, 4.3.2

BRIDGES, (*continued*)

 sleeves in, 4.3.1.4, 4.3.1.8, 4.4.2, 4.6
 spare pipe in, 4.3.1.5
 unauthorized access to pipes in, 4.3.3
Building and Site Requirements for Pump Stations, 7.10, 7.10.1, 7.10.2, 7.10.3, 7.10.4
Bypass Pumping (temporary) for Pump Stations, 7.11.2.2, 7.11.2.3

C

CALCULATIONS,

 corrosion control, 6.1
 critical speed, 7.2.4
 deflection, 1.4.2.3, 2.2.3.2, 2.5.2
 design, 2.10, 3.2.2.8, 4.3.4
 differential movement, 4.3.4 flow, 1.3.2.2, 1.5.1, Table 1-1
 hydraulic, 1.3.2.2, 1.3.3.1,
 hydraulic losses, 7.2.3.4
 invert drop, 2.3.6.1, 2.3.6.2
 loading, 2.2.3.2, 2.5.2, 3.3.2, 4.3.4
 net positive suction head (NPSH), 7.2.3.6
 pump, 7.2.3, 7.2.3.7
 pumping capacity, 1.5.1, 7.2.2.1
 settlement, 2.2.2.3, 2.2.3.2
 standing wave, 2.3.3(b)
 structural (for manholes), 2.3.10
 surge pressure, 7.2.5
 wet well, 7.2.6
CALTRANS encroachment permit, 4.2.2
Canyon Sewers, 1.2.1.1, 1.2.1.2, 1.2.1.3, 1.2.3, 1.3.1.4, 2.2.5.4, 2.8.7Capacity, 1.3.1.1, 1.5.1, 1.7.2, 7.2.8.1
Casing, 2.2.1.4, 3.3.2, 4.3.1.4, 4.3.1.8, 4.4.2, 4.4.4.3, 4.6
Cathodic Protection, 4.4.5, 6.2, 6.2.2, 6.2.3, 6.2.5, 6.2.6, 6.3, 6.3.2, 6.3.3, 6.3.4, 6.4, 6.4.1, 6.4.2, 6.4.3, 6.6
CC&R, 1.2.1.4, 1.5.2, 2.8.5
Check List, quality control, 2.9
Check Valves, 7.2.5.3.5, 7.4.2, 7.4.2.1, 7.4.2.2, 7.4.2.3, 7.4.3.11, 7.7.5.3
City Clerk, 3.4.2.1
Cleanout, 2.5.4, 2.5.7, 2.5.16(b), 2.6.1, 2.7.4 (g),(h), 7.7.5.3, 7.9.2.4, 7.10.4.5
Coating and Lining, 4.4.1.1, 4.4.5, 6.1, 6.2, 6.3, 6.4, 6.5, 6.7, 7.8.5.1, 7.8.5.2
Coating Selection Guide, Tables 6-2, 6-6, 6-7

Coatings, valves, 6.7.3, Table 6-6, 7.4.1.1
Color Identification Scheme for Piping and Equipment in Pump Stations, 7.7.4
Concrete Anchors, 2.2.8, Table 2-1
Concrete Encasement, 1.4.2.3, 2.2.1.4, 2.4.3, 2.5.2, 2.7.4(d), 3.2.3.2, 6.2.7, 6.2.9
CONNECTIONS,
 lateral, 2.2.1.5, 2.5.1(f), 2.5.2, 2.5.7, 2.5.8, 2.5.11, 2.6.3, 2.7.3, see also LATERALS
 lateral, to trunk sewer, 2.5.9
Constant Speed Pumps, 7.2.3.1, 7.2.6.4
Construction Management of Pump Stations, 7.11, 7.11.2
Cooling Systems in Pump Stations, 7.6.7
CORROSION CONTROL, Chapter 6
 aluminum, 6.2.4
 coating selection guide, Table 6-2
 concrete, 6.2.1, Table 6-5
 copper and brass, 6.2.5
 ductile iron, 2.2.1.6, 2.7.3, 4.4.5, 6.2.3, 6.4, 7.9.1.4
 ferrous pipelines, 2.2.1.6, 2.7.3, 4.4.5, 6.2.2, 6.2.3, 6.3.1, 6.4, Table 6-5, 7.9.1.4
 fiberglass, 6.2.8
 lining selection guide, Table 6-3
 material selection, 6.2, Table 6-1, 6.5
 monitoring, 6.4, 6.6
 polyvinyl chloride (PVC), 6.2.7
 pre-design surveys, 6.3
 pump stations, 6.7, 7.5.6.2, 7.8.5, 7.9.1.4, 7.9.1.7
 soil resistivity, 6.3, 6.3.1, Table 6-4
 stainless steel, 6.2.6
 steel, 2.2.1.6, 6.2.2, 6.3.2, 6.4, Table 6-5
 stray currents, 6.3.3, 6.3.4
 testing, 6.3, 6.3.1, 6.3.2, 6.4.3
 vitrified clay pipe, 6.2.9
Council Policy 400-13, 1.2.1.1, 1.2.1.2, 1.2.1.3, 1.2.2, 1.2.3, 1.3.1.4, 1.5, 1.8(v), Attachment 1
Council Policy 400-14, 1.2.1.1, 1.2.1.2, 1.2.1.3, 1.2.2, 1.2.3, 1.3.1.4, 1.5, Attachment 1
Council Policy 700-18, 3.3.1
County Administration Building, 3.4.2.3
County Recorder, 3.4, 3.4.2.3, 5.2
Cover, 2.2.1.5
Crossings, skew, 2.2.6
CURVATURE, 2.2.9
 horizontal, 2.2.9.3
 in flexible pipes, 2.2.9.2
 in rigid pipes, 2.2.9.1

CURVATURE, (*continued*)
 minimum allowable radius, Table 2-3
 vertical, 2.2.9.4
Curves, vertical, 1.3.3.1, 2.2.4, 2.2.9.4, 2.3.1.1(c), 2.3.1.5,
Cutoff Walls, 2.2.8, 7.9.1.10

D

Dead End Sewers, 2.2.1.7, 2.3.1.1(e), 2.3.1.6
 d_r/D , 1.3.3.3, 1.7.1, 1.7.2, 2.2.4, 2.2.7, 2.3.6.2
DEFLECTION,
 for shallow mains, 1.4.2.1, 2.2.1.3, 2.2.1.6
 joint, 2.2.9.1, 2.2.9.2, Table 2-3
 longitudinal, 4.3.4
 of PVC pipe, 2.2.1.2
Dehumidifier in Pump Stations, 7.6.6
DEPTH,
 of dead end mains, 2.2.1.7
 of flow, 1.3.3.3
 of laterals, 2.2.2.1, 2.5.2
 of mains, 1.3.1.3, 2.2.1.5, 2.2.1.6, 2.2.2.1
 of manholes, 2.3.10
 of sewers greater than 15 feet, 1.3.1.3, 2.2.1.5, 2.2.2.3, 2.3.10
Design Deviation, 1.3.1.3, 1.4.1.1, 1.4.2.1, 1.4.2.3, 2.2.1.5, 2.2.1.7, 2.2.2.3, 2.2.5.3, 2.2.5.9, 2.2.6, 2.5.3, 3.2.2.2, 3.2.2.4, 3.2.4.2, 3.3.2, 7.1.1.5, Attachment 2
Direction, maximum change in, 2.2.2.2, 2.2.3.1, 7.9.1.11
Drainage Basin, 1.3.1.2
Drawings, Shop, 2.2.3.3, 2.2.9.3, 2.7.1, 2.7.3, 2.7.4(d), 2.10
Drive Shafts in Pump Stations, 7.3.3
Driveways, private, 2.2.5.7, 2.3.1.2(d), 2.5.1(a), 2.5.1(b), 2.7.3, 3.2.2.7, 3.2.3.3
Dry Weather Peak Flow/Factor, 1.3.2.2, 1.3.3.1
Dry Well, 7.4.1.1, 7.6.1.1, 7.7, 7.7.1
Ductile Iron Pipe, 2.2.1.6, 2.7.3, 4.4.1.1, 4.4.4.1, 4.4.5, 6.2.3, 6.4.3, 7.4.3.1, 7.4.3.2, 7.9.1.4

E

EASEMENTS, Chapter 3
 abandonment of, 5.1, 5.3
 access, 1.2.1.5, 2.7.4(i), 3.2.1.3, 3.2.2.7
 adjacent to slopes or walls, 3.2.2.8
 adjacent to structures, 3.2.2.3, 3.2.2.8
 by grant deed, 3.4, 3.4.2, 3.4.2.3

EASEMENTS, (continued)

by map, 3.4, 3.4.1
 fenced, 3.2.1.4
 in areas of geotechnical concern, 3.2.2.9
 in commercial property, 3.2.2.7
 in open space, 3.2.2.5
 in parklands, 3.2.2.6
 in private streets, 3.2.2, 3.2.2.7, 3.2.4.3
 laterals in, 2.5.11, 3.2.4.3
 location of, 3.2.1, 3.2.1.2
 location of sewers in, 3.2.4.1
 minimum, based on depth of sewer, 3.1, 3.2.2, 3.2.2.1, 3.2.2.2, Table 3-1
 multiple use, 3.2.2.4, 3.2.4.2
 private, 2.5.1(g), 2.5.14(a), 3.2.4.4
 records search/research for, 3.4
 sewer, 1.2.1.5, 2.8.3, 3.1, 3.2
 structures adjacent to, 3.2.2.3, 3.2.2.8
 structures encroaching in, 3.3.1, 3.3.2
 substandard, 3.1
 width requirements, 3.1, 3.2.2, 3.2.2.1-10, Table 3-1, 3.2.4.2
 width rounding of, 3.2.2.10

Electrical Controls and Instrumentation, 7.5, 7.5.3, 7.7.6.1, 7.8.6

Emergency Storage, 7.2.6.7, 7.2.6.8, 7.2.7, 7.8.4

EMRA, 2.5.1(b), 2.5.13., 2.8.4, 3.3.2, 3.3.3.4, 4.2.1

Encasement, 1.4.2.3, 2.2.1.4, 2.2.1.6, 2.4.1, 2.4.3, 2.5.2, 2.7.4(d), 3.2.3.2, 4.4.2, 6.2.3, 6.2.7, 6.2.9

Encroachments, 2.10, 3.1, 3.3, 3.3.1, 3.3.2, 3.3.3

Encroachment Laterals, 2.5.1(b), 2.5.12, 2.5.13, 2.5.14, 2.5.16(a), 2.7.4(g),

Environmental Constraints, 1.2.1.3, 1.2.3, 3.2.3.4, 3.3.3.1, 3.3.3.2, 3.3.3.3

Equipment Clearances in Pump Stations, 7.3.4

Equipment Hoisting and Removal in Pump Stations, 7.7.2

Equivalent Population, 1.3.2.2, 1.6, Table 1-1

Existing Planning Studies, 1.3.1.4

F

Facility Acceptance of Pump Stations, 7.11.5
 Facility Testing of Pump Stations, 7.11.3
 Facility Training for Pump Stations, 7.11.7
 Fee Title Ownership in Pump Stations, 7.10.4.1

Fittings in Pump Station Piping, 7.4.3, 7.4.5, 7.4.7.3, 7.7.5.3, 7.8.5.2, 7.9.1.3, 7.9.1.11

Flood, 100 year, 2.2.1.3, 2.2.5.5, 2.2.5.6, 2.2.10(a), 2.3.1.2(b), 3.2.3.4(b), 7.10.4.8

FLOW,
 calculation, 1.3.2.2, 1.5.1, Table 1-1
 estimation, 1.3.2, 1.7.1, 1.7.2, Table 1-1
 depth of, 1.3.3.3, 2.2.4, 2.2.7
 projected peak, 1.3.3.3, 1.5.1, 1.7.1

FORCE MAINS, 2.10, 7.2.8, 7.9, 7.9.1
 capacity of discharge sewer, 7.2.8.1
 coating and lining of, 6.8.2, Table 6-7, 7.9.1.4
 discharge of, 2.3.1.1(h), 2.3.5.3(c), 2.5.7, 2.5.9(d), 7.9.3.1
 drain lines for, 7.4.4, 7.9.1.12, 7.9.2.3
 dual, 7.4.3.12, 7.9.1.2
 emergency pumping connection, 7.9.2.4
 general requirements, 7.9.1
 isolation valves in, 4.3.1.7, 7.9.1.5, 7.9.2.2
 retention time in, 7.2.8.2
 separation of, 7.9.1.13
 velocities in, 7.2.3.5, 7.9.1.1

FPS (feet per second), 1.3.3.1, 2.2.7, 2.3.6.1, 6.2.9, 7.2.3.5, 7.8.2.3, 7.9.1.1

Freeboard, 2.3.3

G

Gas Detection and Monitoring, 7.5.3.2, 7.7.3

Gate, access, 3.2.1.4, 7.10.4.4

Geotechnical report, 2.1(b), 2.2.2.3, 2.2.3.2

Grant Deed, 3.4, 3.4.2

GROUNDWATER, 1.4.1.1, 2.3.5.3(e)
 water table, 2.2.1.3, 2.3.5.4, 2.4.2
 waterproofing, 2.3.5.2, 2.3.5.4, 7.10.1.2

H

HYDRAULIC JUMP, 2.2.4, 2.3.1.5, 2.3.5.3(d)
 height of, 2.2.4
 requirements for, 1.3.3.1, 2.2.4

Hydrostatic Uplift, 2.2.1.3

I

Improvement Plans, 2.7 - 2.10, *see also* PLANS

Infiltration, 1.3.2.2, 1.3.3.1, 2.3.5.2, 2.6.1

Inlet Design for Pump Stations, 7.8.1

Intake Standards, 1.3.1, 2.8, 2.10

Isolation Valves, 4.3.1.7, 7.4.1, 7.9.1.5, 7.9.2.2

J

JOINTS, 4.4.3, 4.4.4
at bridge transitions, 4.4.4.3
ball and socket, 4.4.3.5, 4.4.4.3
bevel, 2.2.9, 2.2.9.1(b), 2.2.9.3
expansion, 4.3.4, 4.4.4.1, 4.4.4.2, 4.4.4.3
flanged, 4.4.3.1, 4.4.4.1
for ductile iron pipe, 4.4.4.1
in pump stations, 7.4.3.5
mechanical, 4.4.3.3, 4.4.4.1, 7.9.1.9
pull, 2.2.9, 2.2.9.3
push-on, 4.4.3.2, 4.4.3.4, 4.4.4.1
restrained, 4.4.4.1, 7.4.3.5, 7.9.1.9
restrained push-on, 4.4.3.4
riser, 2.3.5.2

K

Keys, 3.2.1.4, 7.10.3.2, 7.11.8

L

Land Use, 1.3.2.1, 1.6
Landscaping for Pump Stations, 7.10.6
LATERALS, 2.5, 2.7.5.3
abandonment of, 2.5.15, 2.5.16(e)
allowable locations, 2.5.1, 2.5.8.1,
Table 2-6
allowable types, 2.5.8.2
backwater devices, 2.5.6
bedding of, 2.5.5
cleanouts, 2.5.4
common, 2.5.10
connection of, 2.5.8
connection to trunk sewers, 2.5.9
crossing lot lines, 2.5.1(g), 2.5.14
data table, 2.7.5.3, Table 2-10
deep-cut, 2.5.3
depth requirements, 2.5.2
easement, 2.5.1(f), 2.5.11, 3.2.4.3
encroachment, 2.5.1(b), 2.5.12, 2.5.13,
2.5.14(b), 2.5.16(a), 2.7.4(g)
existing, 1.2.1.2, 2.5.1(a), 2.5.16
in driveways, 2.5.1(a), 2.5.1(b)
in private streets, 2.5.11, 3.2.4.3
location of, 2.5.8.1, 2.5.9
minimum depth of, 2.2.2.1, 2.5.2
minimum spacing of, 2.5.1
on deep sewers, 2.2.1.5(f), 2.5.2

LATERALS, (continued)

pressure, 2.5.7, 2.5.9(d)
private, 2.5.1, 2.5.11, 2.5.13, 2.5.14
at property line, 2.2.2.1, 2.5.2, 2.5.4, 2.5.7,
2.5.10, 2.5.12, 2.7.4(g)
rehabilitation of, 2.5.16, 2.6.3
replacement of, 1.2.1.2, 2.5.4, 2.5.16
required rise of, 2.5.8.4, Table 2-7
size of, 2.5.8.3
slope of, 2.5.3

LENGTH,

between manholes, 2.3.2, Table 2-4
minimum for vertical curves, 2.2.9.4(b)

LINING, 2.2.1.6, 2.3.5, 2.5.4, 4.4.1.1, 6.2.1, 6.7

force main, 6.7.2, Table 6-7
manholes, 2.3.5.1, 2.3.5.3, 2.5.7, 6.2.1
pump station, 6.7.2, Table 6-7, 6.7.4
wet wells, 6.7.5

Lining Selection Guide, Table 6-3

Load Factors, 2.4.3

LOADING,

H-20, 3.2.3.1, 3.2.3.3, 3.2.3.4(b), 7.7.1.4,
7.7.2.5, 7.10.4.2
on clay pipe, 2.4.3
on sewers, 2.2.1.1, 2.2.1.3, 2.2.1.6,
2.2.3.2, 2.5.2, 3.2.2.8, 4.3.4
pavement, 3.2.3.1, 3.2.3.3, 7.10.4.2

M

MAINS, 2.2

15" & smaller in diameter, 1.3.3.3,
2.2.2, 3.2.2.1
18" & larger in diameter, 1.3.3.3, 2.2.3,
2.2.7, 2.3.5.3(a), 2.10, 3.2.2.1
abandonment, 2.7.5.1, 5.2
alignment, 1.2.1, 2.2.5, 3.2.1.1, 4.3.2
bedding, 2.4
bending of flexible pipes, 2.2.9.2
capacity of, 1.3.1.1, 1.7.1, 1.7.2, 7.2.8.1
cover over, 2.2.1.5
crossing, 1.4.2.3, 2.2.6
dead-end, 2.2.1.7, 2.3.1.1(e), 2.3.1.6
deeper than 15 feet, 2.2.1.5, 2.2.2.3, 2.5.2
design of, 2.2, 3.2.1.1, 4.3.1
ductile iron, 2.2.1.4(d), 2.2.1.6, 2.7.4(d),
4.4.1.1, 4.4.4.1, 4.4.5, 6.2.3
easement, 1.2.1.5, 3.2.4.1, 3.2.4.2
environmental constraints on, 1.2.1.2,
1.2.3, 3.2.3.4, 3.3.3.1, 3.3.3.2

MAINS, (continued)

excavation of, 3.2.2, 3.2.2.8, 3.2.2.9
 force, *see* FORCE MAINS
 in bridges, Chapter 4, 4.3.1, 4.3.2,
see also BRIDGES
 maximum change in direction, 2.2.2.2,
 2.2.3.1
 maximum depth of, 1.3.1.3, 2.2.1.5
 minimum depth of, 2.2.1.6, 2.2.2.1
 minimum size of, 1.3.3.4
 parallel, 1.4.2.2
 polyvinyl chloride (PVC), 2.2.1.2, 2.2.1.4(b),
 2.2.2.3, 2.2.3.2, 2.5.2, 6.2.7, 6.3
 private, 1.2.1.4, 2.7.3(8)
 profile, 2.2.7, 2.7.2.1(b),
 public, on single lots, 3.2.2.7
 reinforced concrete, 2.2.9.3, 6.2.1
 relocation of, 1.2.1.2, 3.3.2
 replacement of, 1.2.1.2, 2.3.1.6(b), 2.5.16
 separation of, 1.4, 2.2.5.10, 2.7.3(7)
 shallow, 2.2.1.6
 sizing criteria, 1.3.3.3, 1.3.3.4
 steel, 2.2.1.6, 6.2.2, 6.2.6, 6.4
 vitrified clay, 2.2.1.4(d), 2.4.3, 2.2.9.1(a),
 6.2.9

MANHOLES, 2.3

abandonment of, 5.2
 access to, 2.3.1.2(a), 2.3.1.4, 2.3.11,
 3.2.1.3, 3.2.3.1, 3.2.3.2, 3.3.2
 bases, 2.3.5.1, 2.3.8
 deep, 2.3.10
 discharge, 2.3.1.1(h), 2.3.5.3(c), 2.5.7, 7.9.3
 distance between, 2.3.2, Table 2-4
 drop, 2.3.1
 frames & covers, 2.3.4
 inspection of existing, 2.3.11
 invert drops across, 2.3.6, 2.3.7, Table 2-5
 large diameter, 2.3.9
 lining & grouting, 2.3.5
 locking covers, 2.3.1.4
 maximum drop across, 2.3.7
 minimum drop across, 2.3.6, 2.3.6.1,
 2.3.6.2, Table 2-5
 minimum shelf elevation, 2.3.3
 minimum size, 2.3.8
 outboard shelf, 2.3.3
 outlet pipe larger than inlet, 2.3.6.2
 outlet pipe same as inlet, 2.3.6.1
 outlet pipe smaller than inlet, 2.3.6.2
 outside paved areas, 2.3.1.4

MANHOLES, (continued)

outside public right-of-way, 2.3.1.4
 prohibited locations, 2.3.1.2
 PVC lined, 2.3.5.3, 2.5.7, 2.7.4(b), 6.2.1
 required locations, 2.2.3.1(a), 2.3.1.1,
 2.3.1.5, 2.3.1.6(a), 2.5.7, 4.3.1.6
 rim elevations, 2.3.1
 riser joints, 2.3.5.2
 risers, 2.3.5.3, 2.3.12
 rungs, 2.3.1
 side inlet, 2.2.2.2(c), 2.2.3.1(b), 2.3.1.3,
 2.3.3(a), 2.3.6.1(c)(d), 2.3.7
 straight thru flow, 2.3.6.1(a)(b)
 working platform, 2.3.3(a)
 Manning's Coefficient, 1.3.3.1, 2.2.7
 Map Exhibit Criteria, 1.3.4, 1.8
 Material Selection Guide (corrosion), Table 6-1
 Minimum Intake Standards, 1.3.1, 2.8
 Motors in Pump Stations, 7.2.3.7.6, 7.3.2,
 7.5.2.7, 7.5.2.8, 7.5.3.10, 7.5.3.11

N

Net Positive Suction Head (NPSH), 7.2.3.6
 Noise Attenuation in Pump Stations, 7.6.3

O

Odor Control, 1.7.3, 2.5.9(a), 7.6.5, 7.8.7, 7.9.4
 Open Space, 2.2.1.5(g), 2.2.10(k), 3.2.2.5,
 3.2.3.4(b), 3.3.3.1
 Operations and Maintenance Manual for Pump
 Stations, 7.11.4
 Operational Testing of Pump Stations, 7.11.3
 OSHA Requirements, 3.2.2, 3.2.2.9
 Outboard Shelf, 2.3.3

P

Parking for Pump Stations, 7.10.4.5, 7.10.4.7
 Parklands, 3.2.2.6, 3.2.3.3
 Peaking Factor, 1.3.2.2, Figures 1-1, 1-2
 Pipes, *see* MAINS
 Piping in Pump Stations, 6.7.2, 7.4.3, 7.4.4, 7.9
 PLANNING STUDY, 1.3, 1.5.2, 2.8.2
 capacity, 1.3.1.1, 1.7
 depth of mains, 1.3.1.3
 drainage basin, 1.3.1.2
 existing, 1.3.1.4
 flow estimation, 1.3.2, 1.5.1

PLANNING STUDY, (*continued*)

general requirements, 1.1, 1.3.1

PLANS,

data tables, 2.7.5

for pipelines, 2.7.2.1

legend items, 2.7.4

notes on, 2.7.3

requirements, 2.7.1, 2.7.2, 2.7.2.3, 2.10

special facilities, 2.7.2.2, 2.10

Power Switchgear and Distribution in Pump Stations, 7.5.2

Precedence of Sewer Facilities, 1.2.1.3

Private Driveways, 2.2.5.7, 2.3.1.2(d), 2.5.1(a), 2.5.1(b), 2.7.3, 3.2.2.7, 3.2.3.3

Private Easements, 2.5.1(g), 2.5.14(a), 3.2.4.4

Private Laterals, 2.5.1, 2.5.11, 2.5.13, 2.5.14

Private Streets, 2.5.11, 3.2.2.4, 3.2.2.7, 3.2.4.3

Profile of Sewers, 2.2.7, 2.7.2.1(b)

P-Traps, 2.5.9

PUMP STATIONS, 1.2.2, 1.5, 1.7.2, 6.7, Chap. 7

access hatches, 7.7.1.4, 7.7.1.11, 7.7.2.2, 7.7.2.3, 7.7.2.5, 7.8.4.2, 7.8.4.3, 7.8.8

access roads, 7.10.4

alternate power source, 7.5.5, 7.6.4

building and site requirements, 7.10

bypass pumping, 7.11.2.2, 7.11.2.3

capacity, 1.5.1, 1.7.2, 7.2.2

capacity factor, 1.5.1

check valves, 7.4.2

coating of valves in, 6.7.3

coatings and linings in, 6.7

color identification scheme, 7.7.4

construction management, 7.11.2

cooling systems, 7.6.7

corrosion control in, 6.7, 7.5.6.2, 7.8.5, 7.9.1.7

dehumidifier, 7.6.6

design comments for, 7.1.1.4

design document requirements, 7.1.1.7

design meetings for, 7.1.1.6

drive shafts, 7.3.3

dry pit submersible, 7.3.7.1.2

dry well, 7.7, 7.7.1

effect on downstream sewers, 1.7.2

electrical controls and instrumentation, 7.5, 7.5.1, 7.5.2, 7.5.3, 7.8.6

emergency storage, 7.2.6.7, 7.2.6.8, 7.2.7, 7.8.4

energy efficient design, 7.1.1.2

PUMP STATIONS, (*continued*)

equipment clearances in, 7.3.3.2, 7.3.4, 7.7.1.15, 7.7.2.1

equipment hoisting and removal in, 7.7.2

facility acceptance, 7.11.5

facility testing, 7.11.3

facility training, 7.11.7

fee title ownership in, 7.10.4.1

fencing, 7.10.4.3

fittings, 7.4.3, 7.4.5, 7.4.7.3, 7.9.1.6

force mains, 7.2.8, 7.4.3.12, 7.9, 7.9.1, 7.9.2

gas monitoring/detection in, 7.5.3.2, 7.7.3

gates, 7.10.4.4

general design requirements, 7.1, 7.1.1.1, 7.1.1.3, 7.10

hydraulic losses in, 7.2.3.4

inlet design, 7.8.1

isolation valves, 7.4.1, 7.9.1.5, 7.9.2

keying requirements, 7.10.3.2, 7.11.8

landscaping requirements, 7.10.6

large, 7.3.6

lining of wet wells in, 6.2.1, 6.7.5, 7.8.5.1

location of, 1.2.2, 1.5

minimum inflow, 7.2.6.4

motors, 7.2.3.7.6, 7.3.2, 7.5.2.7, 7.5.2.8, 7.5.3.10, 7.5.3.11

net positive suction head (NPSH), 7.2.3.6

noise attenuation in, 7.6.3

odor control in, 7.6.5, 7.8.7, 7.9.4

operating volume of, 7.2.6.3, 7.2.6.5

operational testing, 7.11

operations and maintenance manual, 7.11.4

other requirements, 7.5.6

overhead cranes in, 7.4.3.4, 7.7.2

parking requirements, 7.10.4.5, 7.10.4.7

pipings, 6.7.2, Table 6-6, 7.4.3, 7.4.4, 7.9

planning of, 1.2.2, 1.5

power switchgear and distribution, 7.5.2

private, 1.5, 1.5.2, 7.1.1.8

public, 1.5, Chapter 7

pump curves for, 7.2.3.7

pump selection for, 7.2.3.7

restroom for, 7.10.5.5

retrofits of, 7.3.7.1, 7.4.7.5, 7.4.7.6

seismic design, 7.4.3.9, 7.5.2.10, 7.5.5.1.1(b)

self-cleaning wet well, 7.8.2.3, 7.8.3.3

small appurtenance fittings, 7.4.5

spare parts for, 7.3.5, 7.6.5.2

PUMP STATIONS, (*continued*)

- special station requirements, 7.1.1.5, 7.2.3.2, 7.2.7, 7.3.3.4, 7.3.6, 7.3.7, 7.4.1.8, 7.4.2.3, 7.4.3.6.1, 7.4.4.2, 7.4.7.5, 7.4.7.6, 7.5.2.5(c), 7.5.5.2.1, 7.5.5.4, 7.5.6.2, 7.6.1.6, 7.6.5.2, 7.6.6.1, 7.6.7.1, 7.6.7.2, 7.7.1.6, 7.7.1.11, 7.7.2.3, 7.8.1.3, 7.8.2.3, 7.8.3.2, 7.8.3.3, 7.8.3.4, 7.8.8.2, 7.9.1.4, 7.9.1.12, 7.10.5.4, 7.10.5.5, 7.11.2.2
- surge pressure in, 7.2.5
- telemetry, 7.5.4, Attachment 3
- trash rack, 7.8.3
- valves, 7.2.5.3.3-5, 7.4.1, 7.4.2, 7.4.7, 7.8.8.2, 7.9.1.5, 7.9.1.14, 7.9.2.1, 7.9.2.2
- ventilation, 7.1.1.2, 7.6, 7.6.1, 7.6.2, 7.6.4, 7.6.5, 7.8.7
- walls, 7.9.1.10, 7.10.1.2, 7.10.1.3, 7.10.4.3
- warranty requirements, 7.11.6
- water meter and backflow protection requirements, 7.7.1.18, 7.10.5, 7.10.6.3
- wet well, 6.7.5, 7.2.6, 7.6.5, 7.8

PUMPS, 7.2.3, 7.3

- bases for, 7.3.1.6, 7.3.1.7
- constant speed, 7.2.3.1, 7.2.3.2, 7.2.6.4
- critical speed of, 7.2.4
- curves for, 7.2.3.7
- dry pit submersible, 7.3.7.1.2
- motors for, 7.2.3.7.6, 7.3.2, 7.5.2.7, 7.5.2.8, 7.5.3.10, 7.5.3.11
- number of service and standby, 7.2.3.3
- selection criteria for, 7.1.1.2, 7.2.3.7.1-10
- self-priming, 7.4.7.5
- submersible, 7.4.7.6, 7.7.2.3
- sump, 7.7.5
- variable speed, 7.2.3.1, 7.2.3.2, 7.2.6.3, 7.3.6.2
- vertical non-clog, 7.3.1
- wet well submersible, 7.3.7.1.3
- PVC, 2.2.1.2, 2.2.1.4(b), 2.2.1.4(d), 2.2.2.3, 2.2.3.2, 2.2.3.3, 2.2.9.2, 2.5.2, 6.2.1, 6.2.7, 6.7.5, 7.8.5.1, 7.9.1.3

Q

- Quality Assurance/Quality Control, 2.8

R

- RADIUS OF CURVATURE, 2.2.9, 2.2.9.1, 2.2.9.2, 2.2.9.3, Table 2-2, Table 2-3
 - minimum, 2.2.9, 2.2.9.1, 2.2.9.2, 2.2.9.3, Table 2-2, Table 2-3, 2.7.5.2
- REHABILITATION, 2.6, 7.1.1.7
 - laterals, 2.5.4, 2.6.3
 - manholes, 2.3.5.1, 2.6.2
 - pipelines, 2.6.1
- Resistivity, soil, 6.2.2, 6.3, 6.3.1, Table 6-4
- Restroom for Pump Stations, 7.10.5.5
- ROADS,
 - access, 1.2.1.3, 1.2.3, 3.2.1.3, 3.2.2.7, 3.2.3
 - minimum radius on access, 3.2.3.1

S

- Schedule "J" Paving, 2.7.4(i), 3.2.3.1, 3.2.3.4(b)
- Seismic Design, 2.1(b), 4.3.4, 7.4.3.9, 7.5.2.10, 7.5.5.1.1(b)
- Self-Cleaning Wet Wells, 7.8.2.3, 7.8.3.3
- SEPARATION,
 - from other utilities, 1.4.1.2, 2.2.5, 2.5.1, 3.2.2.2, 3.2.2.4, 3.2.4.1, 3.2.4.2
 - from trees, 2.2.5.4, 2.2.10(e), 2.7.3(11), 3.3.3
 - horizontal, 1.4.1
 - of mains, 1.4, 2.2.5.10, 2.7.3(7)
 - utility crossings, 1.4.2.3, 2.2.6
 - vertical, 1.4.2
- Settlement, 2.2.2.3, 2.2.3.2, 4.3.4
- Sewer Notes, 2.7.3
- Sewer Study, *see* PLANNING STUDY
- SEWERS, *see also* MAINS
 - canyon, 1.2.1.1, 1.2.1.2, 1.2.3, 1.3.1.4, 2.2.5.4, 2.3.5.4, 2.8.7, 3.2.3.4
 - data tables, 2.7.5
 - dead-end, 2.2.1.7, 2.3.1.1(e), 2.3.1.6
 - laterals, 2.5, - *see also* LATERALS
 - public, on single lots, 3.2.2.7
 - study, *see* PLANNING STUDY
- Shop Drawings, 2.2.3.3, 2.2.9.3, 2.7.3(6), 2.10
- Shrubs, 2.2.10(e), 3.2.3.4(a), 3.3.3.1(b), 3.3.3.3
- Side Yards, residential, 3.2.3.2
- Skew Crossings, 2.2.6
- SLOPE, 1.3.3.1, 1.3.3.2, 2.6.1
 - access roads, 1.2.3(f), 3.2.3.1, 3.2.3.4(b)(c)
 - laterals, 2.5.3, 2.5.8.4
 - minimum, 1.3.3.1, 2.5.3, 2.6.1
 - through manholes, 2.3.6.1, 2.3.6.2

Soil Reports, 2.1(b), 2.2.2.3, 2.2.3.2, 2.2.5.9, 6.3
Special Facilities, 2.7.2.2, 2.10
Special Station Requirements, see PUMP STATIONS, special station requirements
Standing Wave, 2.2.3.1(b)(c), 2.3.3, 2.3.6.1(d)
State Of California Separation Requirements, 1.4.1.1, 1.4.2.3, 2.2.5.10, 2.7.3(7)
Stray Currents, 6.3, 6.3.3, 6.3.4
STRUCTURES,
 adjacent to easements, 2.2.5.9, 3.2.2.3
 encroaching in easements, 3.3.1, 3.3.2
 vault, 2.2.3.1, 2.3.3(a), 2.3.9, 2.3.10
Substandard Easements, 3.1

T

Telemetry in Pump Stations, 7.5.4, Attachment 3
Terrain, steep, 2.2.8
Testing, corrosion control, 6.3, 6.3.1, 6.3.2
Trash Rack in Pump Stations, 7.8.3
Trees, 2.2.5.4, 2.2.10(e), 2.5.1(a), 2.7.3(11), 3.3.3.1(a), 3.3.3.3, 7.1.1.2
Trench Details, 2.2.3.4
Turnaround, 3.2.3.1, 7.10.4.5
Turning Radius, minimum, 3.2.3.1, 7.10.4.6

U

Utility Crossings, 1.4.2.3, 2.2.6, 4.3.1.3
Utility Separation, 1.4, 2.2.5, 2.2.6, 2.5.1, 3.2.2.2, 3.2.2.4, 3.2.4.1, 3.2.4.2, 4.3.2

V

VALVES,
 check, 7.2.5.3.5, 7.4.2, 7.4.2.1, 7.4.2.2, 7.4.2.3, 7.4.3.11, 7.7.5.3
 isolation, 4.3.1.7, 7.4.1, 7.9.1.5, 7.9.2.2
 solid wedge type, 7.4.1.1, 7.4.1.6, 7.9.2.1
Variable Speed Pumps, 7.2.3.1, 7.2.3.2, 7.2.6.3, 7.3.6.2
Vaults, 2.2.3.1, 2.3.3(a), 2.3.9, 2.3.10, 4.3.1.8
Vehicular Access, 2.3.1, 3.1, 3.2.1.4, 3.2.2.7, 3.2.3.1, 7.10.4.2
VELOCITY, 1.3.3.1, 2.2.7, 2.3.6.1, 2.6.1, 7.2.3.5, 7.8.2.3, 7.9.1.1
 discharge, 7.2.3.5
 force main, 7.9.1.1
 maximum, 1.3.3.1, 2.2.7, 7.2.3.5, 7.9.1.1, 7.8.2.3

VELOCITY, (*continued*)
 minimum, 1.3.3.1, 2.2.7, 7.9.1.1
 pipe, 1.3.3.1
 suction pipe, 7.2.3.5
Ventilation of Pump Stations, 7.1.1.2, 7.6, 7.6.1, 7.6.2, 7.6.4, 7.6.5, 7.8.7
Vertical Curve, see CURVES, vertical

W

Wet Weather Peak Flow, 1.3.2.2, 1.3.3.3, 1.5.1, 1.7.1
Wet Weather Peaking Factor, 1.3.2.2
Wet Well, 6.7.5, 7.2.6, 7.6.5, 7.8
Width Requirements, easements, 3.1, 3.2.2, 3.2.2.1-10, Table 3-1, 3.2.4.2

Y

Y-Fitting, 2.5.8.2, 2.5.8.3, 2.5.8.4, 2.5.16(c), 7.9.2.4

Z

Zone-Density Conversions, 1.6, Table 1-1

ATTACHMENT 1

CITY OF SAN DIEGO, CALIFORNIA

COUNCIL POLICY

SUBJECT: PLANNING FOR MANAGEMENT OF SEWER FACILITIES LOCATED IN CANYONS AND OTHER ENVIRONMENTALLY SENSITIVE LANDS

POLICY NO.: 400-13

EFFECTIVE DATE: January 22, 2002

BACKGROUND:

Historically, the City's sewer lines were constructed in canyons in certain areas of the City to take advantage of gravity flow. Of the 2,850 miles of sewer lines in the city, approximately 320 miles are currently situated in the City's canyons and other environmentally sensitive lands. Many sewers in canyons are currently inaccessible, making regular inspection, maintenance, and cleaning difficult. To effectively maintain the existing sewer lines, the Metropolitan Wastewater Department (MWW) must gain access to the sewer mains located in the canyons and other environmentally sensitive lands, many of which contain highly sensitive ecosystems.

In February 2000, the Natural Resources and Culture Committee (NR&C) of the San Diego City Council organized a City-Wide Task Force to assist the City in developing a city wide policy(s) for operating, maintaining, and accessing a sewer collection system where environmental health and public safety are protected and impacts to San Diego's urban canyons are eliminated or minimized. A 33-member City-Wide Canyon Sewer Maintenance Task Force was formed, including representation from the City of San Diego, other governmental agencies, environmental organizations, and community groups throughout the City. On March 28, 2001, the City-Wide Canyon Sewer Maintenance Task Force gave their final report and presentation expressing their proposed policies.

This Policy incorporates many of the Task Force's recommendations regarding how to operate, maintain, and access a sewer collection system that is located within canyons and other environmentally sensitive lands when relocation is not economically practical as defined by Policy 400-14, titled Planning for Redirection of Sewage Discharge away from Canyons and Other Environmentally Sensitive Lands.

PURPOSE:

To establish policies and guidelines for safe and effective access, maintenance, and repair of sewer infrastructure located in canyons and other environmentally sensitive lands, while minimizing impacts to sensitive resources. Any subsequent actions taken pursuant to this Policy will be subject to environmental review.

DEFINITIONS:

Emergency Action: An action taken to repair an active or imminent sewage spill.

Urgent Action: An action taken to repair sewer infrastructure that has deteriorated to the point that a break or backup is deemed likely in the near future.

CITY OF SAN DIEGO, CALIFORNIA
COUNCIL POLICY

Sewer Access Road: A graded, cleared or paved sewer access route.

Sewer Access Way: A pre-determined or preferred route to follow for access into a canyon or other environmentally sensitive lands.

GENERAL POLICY:

Wherever economically practical as defined by Policy 400-14, titled Planning for Redirection of Sewage Discharge away from Canyons and Other Environmentally Sensitive Lands, sewer infrastructure should be relocated out of canyons or other environmentally sensitive lands. When sewer infrastructure cannot be or has not yet been relocated, the City shall minimize the construction of new sewer access roads. All other access and maintenance practices and procedures undertaken in canyons and other environmentally sensitive lands shall avoid or minimize impacts to sensitive resources. For those impacts that cannot be avoided, the City should execute timely and complete environmental restoration.

Impacts to canyons and other environmentally sensitive lands shall be minimized or avoided by implementing the following:

- Developing plans for appropriate emergency and scheduled access into canyons and other environmentally sensitive lands;
- Replacing deteriorated sewer infrastructure;
- Employing low environmental impact practices and procedures for all sewer repairs, replacement or routine maintenance;
- Expanding the City's equipment fleet to include low impact, canyon proficient vehicles that can safely access natural areas, while minimizing impacts to sensitive resources;
- Stabilizing erosion that could threaten the integrity of existing sewer infrastructure, water quality and habitat value;
- Implementing timely and effective restoration procedures when impacts do occur;
- Establishing and enforcing high performance standards for contractors and City crews;
- Implementing measures that minimize the need for unscheduled maintenance due to erosion, storm runoff, vandalism, and other factors, such as general deterioration of habitat due to sewer operations in canyons; and
- Developing a public outreach plan.

Any specific action or course of action taken in accordance with this Policy will be subject to environmental review.

CITY OF SAN DIEGO, CALIFORNIA
COUNCIL POLICY

ACCESS:

Sewer access roads into canyons and other environmentally sensitive lands for purposes of repairing, replacing or maintaining sewer infrastructure shall be avoided whenever possible. Where sewer access paths or roads are necessary for equipment access, they shall be of minimal surface area, require minimal modification to terrain and vegetation, and shall minimize erosion. Surfaces to be considered shall include temporary surfacing materials, permeable surfaces or surfaces that support growing vegetation.

Maintenance Access:

For each canyon or environmentally sensitive land supporting sewer infrastructure, the City shall develop and maintain a Maintenance Access Plan identifying service practices and procedures that minimize environmental damage and community impacts and ensure worker safety.

Emergency Access:

The City shall develop an Emergency Access Policy establishing specialized emergency response teams using specific emergency access plans developed for each canyon supporting sewer infrastructure. This Emergency Access Policy will identify practices and procedures to minimize environmental damage and community impacts, increase worker safety, reduce response times, and provide guidance and confidence to the emergency response teams in making onsite decisions.

SEWER MAIN REPLACEMENT:

Deteriorated sewer mains are a source of sewer spills that pollute San Diego's waterways; therefore, it is the policy of the City to give priority to the repair, replacement or relocation of deteriorated sewer infrastructure.

EMPLOYING LOW ENVIRONMENTAL IMPACT PRACTICES AND PROCEDURES FOR SEWER REPAIRS, REPLACEMENT, AND ROUTINE MAINTENANCE:

All repair, replacement, and maintenance of sewer infrastructure located within canyons or other environmentally sensitive lands shall be conducted in a manner that demonstrates the City's commitment to preserving sensitive natural and cultural resources.

EQUIPMENT:

It is recognized that a fleet of canyon proficient vehicles is necessary to service the different types of terrain and specific sewer maintenance and emergency needs of the various canyons environmentally sensitive lands. The City should evaluate and acquire vehicles and cleaning equipment, both for routine maintenance and emergency repair, that will safely and effectively access, maintain and clean sewers in canyons, and will minimize impact to the canyon's natural and residential environment.

CITY OF SAN DIEGO, CALIFORNIA

COUNCIL POLICY

While cost and expediency are factors, they shall not be the overriding factor in the selection of equipment and cleaning techniques for canyons.

EROSION CONTROL AND RESTORATION:

The hydrological function, habitat, and terrain of canyons impacted by sewer-related activities shall be restored to the maximum extent feasible to their preconstruction or natural condition.

PERFORMANCE:

Performance standards and specifications for work conducted in canyons and other environmentally sensitive lands shall be developed to ensure the protection of sensitive resources.

MINIMIZE THE NEED FOR UNSCHEDULED MAINTENANCE:

To reduce the potential for sewage spills and the need for unscheduled maintenance, steps shall be taken to minimize damage to or blockage of sewer infrastructure resulting from exterior factors such as erosion and vandalism.

Canyons and other environmentally sensitive lands that contain sewer infrastructure shall be regularly monitored for erosion problems, downstream sedimentation, invasive species, inappropriate human intrusion, and roots. If these or other situations could result in damage to sewer infrastructure, they should be corrected in a timely manner.

PUBLIC OUTREACH:

A Public Outreach Plan shall be developed and implemented that will keep community groups, adjoining property owners, and other stakeholders informed of repair, mitigation, and restoration activities occurring within an adjoining canyon or other environmentally sensitive area.

HISTORY

Adopted as R-295976 01/22/2002

CITY OF SAN DIEGO, CALIFORNIA

COUNCIL POLICY

SUBJECT: PLANNING FOR REDIRECTION OF SEWAGE DISCHARGE AWAY FROM CANYONS AND OTHER ENVIRONMENTALLY SENSITIVE LANDS

POLICY NO.: 400-14

EFFECTIVE DATE: January 22, 2002

BACKGROUND:

Historically, the City's sewer lines were constructed in canyons in certain areas of the City to take advantage of gravity flow. Of the 2,850 miles of sewer lines in the City, approximately 320 miles are currently situated in the City's canyons and other environmentally sensitive lands. Many sewers in canyons are currently inaccessible, making regular inspection, maintenance, and cleaning difficult. To effectively maintain the existing sewer lines, the Metropolitan Wastewater Department (MWWD) must gain access to the sewer mains located in the canyons and other environmentally sensitive lands, many of which contain highly sensitive ecosystems.

In February 2000, the Natural Resources and Culture Committee (NR&C) of the San Diego City Council organized a City-Wide Task Force to assist the City in developing a city-wide policy(s) for operating, maintaining, and accessing a sewer collection system where environmental health and public safety are protected and impacts to San Diego's urban canyons are eliminated or minimized. A 33-member City-Wide Canyon Sewer Maintenance Task Force was formed, including representation from the City of San Diego, other governmental agencies, environmental organizations, and community groups throughout the City. On March 28, 2001, the City-Wide Canyon Sewer Maintenance Task Force gave their final report and presentation expressing their proposed policies and other related recommendations to the NR&C Committee.

One of the alternatives for gaining access to sewer facilities that are located in canyons and other environmentally sensitive lands is to relocate those sewer facilities out of those canyons and other environmentally sensitive lands to more accessible locations. There are, however, cost issues and community impacts that should be considered when deciding to relocate a sewer facility. The City-Wide Canyon Sewer Maintenance Task Force explored and analyzed those issues and provided recommendations in its report on how to incorporate those issues into the decision making process of when to relocate sewer facilities and when not to.

Often, to redirect sewage flow away from canyons and other environmentally sensitive lands, it is necessary to redirect private sewer laterals away from the existing sewer facilities located in the canyons to an existing or proposed sewer facility located in City streets or other accessible locations. Also, redirecting private sewer laterals may create a situation where it is necessary to install a pump system to the private sewer lateral. This situation may arise because the elevation of the private sewer lateral may be lower than the elevation of the existing or proposed sewer main in the street or other accessible location.

This policy incorporates many of the Task Force's recommendations regarding the redirection of sewer flow from canyons and other environmentally sensitive lands.

CITY OF SAN DIEGO, CALIFORNIA
COUNCIL POLICY

PURPOSE:

To establish a feasibility and planning framework for the redirection of sewage discharge away from canyons and other environmentally sensitive lands, including: i) a procedure that the City shall use to determine when to redirect sewer flow from canyons or other environmentally sensitive lands; and ii) parameters that the City shall use when interacting with property owners who will be required to install a pump as a result of redirection of sewer flow from canyons or other environmentally sensitive lands. Any subsequent actions taken pursuant to this Policy will be subject to environmental review.

DEFINITIONS:

1. Individual Lateral Pump:

Individual Lateral Pump means a pump used to direct sewage from a lateral located on private property to the operating sewer main.

2. Property Owner:

Property Owner means the person or entity who has legal ownership of private property affected by Redirection of Flow and who is required to use an Individual Lateral Pump in order to maintain sewer service in the City of San Diego.

3. Redirection of Flow:

Redirection of Flow means the decision by the City to abandon sewer main(s) located in canyons or other environmentally sensitive lands and to redirect sewer flow into existing or newly proposed mains in streets or other accessible locations.

4. Cost-Benefit Analysis:

Cost-Benefit Analysis means the procedure used to assist in determining when Redirection of Flow should be implemented.

5. Stakeholders:

Stakeholders means private property owners, groups, and individuals affected by Redirection of Flow. It includes community planning groups and residents in or adjacent to the project area.

POLICY:

When planning for future projects, the City shall make Redirection of Flow a priority. To assist in determining when to redirect sewer flow, a Cost-Benefit Analysis shall be conducted by the appropriate entity responsible for the project and shall include both quantitative and qualitative costs and benefits of alternatives. The Cost-Benefit Analysis shall consider the life cycle cost of the

CITY OF SAN DIEGO, CALIFORNIA
COUNCIL POLICY

alternatives. The Cost-Benefit Analysis shall be conducted during the early design stages of the project. When estimating the cost to maintain sewer facilities in canyons or other environmentally sensitive lands, the cost of the increased risk of a sewage spill occurring and the cost of the impacts to the canyon habitat resulting from necessary canyon access shall be considered. When the City determines that the risk of a sewer spill occurring and the impacts to canyon or other environmentally sensitive habitat are high, the estimated cost for maintaining sewer facilities located in canyons should be increased by thirty-five percent (35%).

Financial concerns shall not be the only methodology used to determine the feasibility of Redirection of Flow. Environmental analysis will be a part of the feasibility analysis. In addition, City staff shall involve Stakeholders and solicit community input as an integral part of the decision-making process.

If the City determines that Individual Lateral Pumps are necessary to implement a Redirection of Flow sewer project, the City may provide and install Individual Lateral Pumps with City Council approval. If the City provides and installs an Individual Lateral Pump, the Property Owner will own and be responsible for maintenance of the Individual Lateral Pump. In addition, the City and the Property Owner must enter into an appropriate written agreement which must be recorded in the Office of the County Recorder as an agreement affecting real property. Further, the City should provide comprehensive informational resources regarding pump ownership and maintenance to the Property Owner. City staff shall work with the Property Owner and the City Attorney's Office as appropriate to accomplish these purposes.

When it is determined by the City that an Individual Lateral Pump is justified, the City should obtain and install a high quality pump, as determined by the City, with a manufacturer's warranty of five years if available. Further, the City may determine that a one-time lump sum payment to the Property Owner for estimated maintenance costs of the pump over its projected life is appropriate.

Any specific action or course of action taken in accordance with this Policy will be subject to environmental review.

HISTORY

Adopted as R-295976 01/22/2002

CITY OF SAN DIEGO
PUBLIC UTILITIES DEPARTMENT
DEVIATION FROM STANDARDS

CASE/PERMIT/IO NUMBER: _____ COORD: _____

PROJECT DESCRIPTION/LOCATION _____

ENGINEER OF WORK: _____ RCE NO. _____
(Sign Name)

_____ EXP DATE: _____
(Print Name)

(PLACE RCE STAMP HERE)

DESCRIPTION OF DEVIATION:

REASON FOR DEVIATION:

MITIGATION MEASURES FOR DEVIATION:

REVIEWED BY: _____ DATE: _____

APPROVED BY: _____ DATE: _____
DEPUTY CITY ENGINEER

DEPUTY
DIRECTOR: _____ DATE: _____

(PLACE RCE STAMP HERE)

ATTACHMENT 3

A.2.1 GENERAL

ATTACHMENT 3 does not contain any paper hard copies. However, the texts, figures, drawings, and plans included in the following outline of **ATTACHMENT 3** are stored in computer electronic files for the benefit of the Design Engineer. Currently, the custodian of these electronic files is the CADD Section of Engineering and Program Management Division, Public Utilities Department (PUD). **ATTACHMENT 3** is not all inclusive. It includes only electrical, controls, and instrumentation standardized design for wastewater collection system pump stations including plans, construction/installation specifications, and PLC programming. These are generic in nature and the Design Engineer shall modify and edit them on a case-by-case basis to make them project specific. Other disciplines will require design criteria and specifications beyond the contents of **ATTACHMENT 3**. The Design Engineer is referred to the 10-volume Clean Water Program (CWP) Guidelines of PUD which include, by reference, the Standard Specifications for Public Works Construction (SSPWC, also known as The GREENBOOK) and its Regional and City of San Diego Supplement Amendments (also known as the WHITEBOOK), plus local, state, and federal requirements, as well as industrial and commercial codes, standards, and specifications. For requirements outside the PUD's CWP Guidelines, the Design Engineer shall be responsible for providing and developing specifications from their own resources. On request, copies of the electronic files referred to in **ATTACHMENT 3** can be made available to the Design Engineer.

The computer electronic files for the following specification sections, standard drawings, schematic flow charts, and SCADA flow diagrams are available with the CADD Section of PUD. They can be obtained upon request.

A.2.2 ELECTRICAL STANDARDIZED DESIGNS AND SPECIFICATIONS

- Section 16040 - Electric Motors
- Section 16110 - Raceways, Fittings, and Supports
- Section 16120 - Wire and Cable
- Section 16130 - Junction and Device Boxes and Fittings
- Section 16150 - Wiring Devices
- Section 16155 - Motor Starters
- Section 16160 - Control Cabinets and Panel Devices
- Section 16400 - Electrical Service Equipment
- Section 16440 - Disconnect Switches and Fuses
- Section 16450 - Grounding
- Section 16460 - Dry Type Transformers
- Section 16470 - Panelboards
- Section 16480 - Motor Control Centers
- Section 16500 - Lighting Fixtures
- Section 16700 - Supervisory Control and Data Acquisition (SCADA), Gas Detection and Intrusion Systems
- Section 16900 - Controls and Instrumentation

A.2.3 STANDARD DRAWINGS (FIGURES 1 TO 30)

Figure SE-1	Typical Electrical Symbols and legends
Figure SE-2	Typical Electrical Symbols and legends
Figure SE-3	Site Plan and Notes
Figure SE-4	Typical Single Line Diagrams
Figure SE-5	Typical MCC Details, Light Fixture Schedule
Figure SE-6	Typical Conduit Schedules
Figure SE-7	Typical Roof Level Power and Lighting Plans
Figure SE-8	Typical Generator Room Level Power Plan
Figure SE-9	Typical Generator Room Level Lighting Plan
Figure SE-10	Typical Pump Room Level Power and Lighting Plan
Figure SE-11	Typical Panel Schedule and Details
Figure SE-12	Typical Miscellaneous Details
Figure SE-13	WWCD SCADA Project, Standard Sewer Pump Station, Pump No.1 Control Schematic
Figure SE-14	WWCD SCADA Project, Standard Sewer Pump Station, Pump No. 2 Control Schematic
Figure SE-15	WWCD SCADA Project, Standard Sewer Pump Station, Pump No. 3 Control Schematic
Figure SE-16	WWCD SCADA Project Standard Sewer Pump Station, Pump Control Schematic Power Distribution
Figure SE-17	WWCD SCADA Project, Standard Sewer Pump Station Pump Control Schematic Pump No.1
Figure SE-18	WWCD SCADA Project, Standard Sewer Pump Station Pump Control Schematic Pump No.2
Figure SE-19	WWCD SCADA Project, Standard Sewer Pump Station Pump Control schematic Pump No.3
Figure SE-20	WWCD SCADA Project, Standard Sewer Pump Station Pump Control Schematic Gas/Generator Monitoring
Figure SE-21	WWCD SCADA Project, Standard Sewer Pump Station Pump Control Schematic Pump Alarms
Figure SE-22	WWCD SCADA Project, Standard Sewer Pump Station Pump Control Schematic Level Control Monitoring
Figure SE-23	WWCD SCADA Project, Standard Sewer Pump Station Pump Control Schematic Pump No. 1 PLC Discrete Inputs
Figure SE-24	WWCD SCADA Project, Standard Sewer Pump Station Pump Control Schematic Pump No. 2 PLC Discrete Inputs
Figure SE-25	WWCD SCADA Project, Standard Sewer Pump Station Pump Control Schematic Pump No.3 PLC Discrete Inputs
Figure SE-26	WWCD SCADA Project, Standard Sewer Pump Station Pump Control Schematic Gas Generator PLC Discrete Inputs
Figure SE-27	WWCD SCADA Project, Standard Sewer Pump Station Pump Control Schematic PLC Discrete Outputs
Figure SE-28	WWCD SCADA Project, Standard Sewer Pump Station Pump Control Schematic PLC Discrete Outputs
Figure SE-29	WWCD SCADA Project, Standard Sewer Pump Station Pump Control Panel Outside Elevation
Figure SE-30	WWCD SCADA Project, Standard Sewer Pump Station Pump Control Panel Inside Elevation

A.2.4 PUMP CONTROL SCHEMES FLOW CHARTS (FIGURES 1 TO 12)

- Figure 1 Level Monitoring and Scaling
- Figure 2 Initial Pump Calls
- Figure 3 Check Valve Fail
- Figure 4 Pump N Availability
- Figure 5 Pump N Run Time Service Call
- Figure 6 Pump Run Time Out
- Figure 7 Pump N Run Sequence Fail
- Figure 8 Pump N Fail/Alarm
- Figure 9 Call 1 Pump Sequence Typical for All Calls
- Figure 10 Station Power Monitor
- Figure 11 Hardwired Float Switch Level Monitoring
- Figure 12 Station Communication Via Radio

A.2.5 SCADA OVERVIEW BLOCK DIAGRAMS (FIGURES 1 TO 3)

- Figure 1 WWCD SCADA Project Sewer Pump Station Programmable Logic Controller Interconnect Diagram
- Figure 2 WWCD SCADA Project Repeater Station Programmable Logic Controller and Radio Component
- Figure 3 WWCD SCADA Project Communication Schematic

ATTACHMENT 4

Low Growing Native Plant Species (Pre-approved for erosion control and access path areas)	
Scientific Name	Common Name
<i>Achillea millefolium</i>	yarrow
<i>Adiantum capillus</i>	maidenhair
<i>Allium spp.</i>	onion- variety
<i>Ambrosia maritima</i>	sand verbena
<i>Ambrosia psilostachya</i>	Western ragweed
<i>Amsinckia spp.</i>	fiddleneck
<i>Anemopsis californica</i>	yerba mansa
<i>Antirrhinum spp.</i>	snapdragon- variety
<i>Apiastrum angustifolium</i>	mock-parsley
<i>Aspidotis californica</i>	lace fern
<i>Astragalus spp.</i>	locoweed- variety
<i>Atriplex triangularis</i>	saltbush
<i>Batis maritima</i>	saltwort
<i>Bloomeria crocea</i>	common goldenstar
<i>Bowlesia incana</i>	bowlesia
<i>Bromus carinatus</i>	California brome
<i>Camissonia californica</i>	sun cup
<i>Calandrinia breweri</i>	Brewer's calandrinia
<i>Calandrinia ciliata</i>	red maids
<i>Calystegia macrostegia</i>	morning glory
<i>Camissonia spp.</i>	sun cup- variety
<i>Cardionema ramosissimum</i>	tread lightly
<i>Carex spp.</i>	sedge - variety
<i>Castilleja spp.</i>	paintbrush - variety
<i>Caulanthus heterophyllus</i>	San Diego jewelflower
<i>Centaureum venustum</i>	canchalagua
<i>Chaenactis artemisiifolia</i>	white pincushion
<i>Chaenactis glabriuscula</i>	pincushion
<i>Cheilanthes clevelandii</i>	lip fern
<i>Cheilanthes newberryi</i>	cotton fern
<i>Chenopodium californicum</i>	California goosefoot
<i>Chlorogalum parviflorum</i>	soap-plant
<i>Chorizanthe spp.</i>	spineflower- variety
<i>Clarkia spp.</i>	clarkia- variety
<i>Claytonia spp.</i>	miner's lettuce- variety

ATTACHMENT 4

<i>Clematis pauciflora</i>	ropevine clematis
<i>Coreopis maritima</i>	sea-dahlia
<i>Cressa truxillensis</i>	alkali weed
<i>Croton californicus</i>	California croton
<i>Cryptantha spp.</i>	cryptantha- variety
<i>Curcubita foetidissima</i>	calabazilla
<i>Cyperus eragrostis</i>	tall flatsedge
<i>Datura wrightii</i>	jimson weed
<i>Delphinium spp.</i>	larkspur
<i>Daucus pusillus</i>	rattlesnake weed
<i>Dodecatheon clevelandii</i>	shooting stars
<i>Dichlostema capitatum</i>	blue dicks
<i>Dienandra fasciculatum</i>	fascicled tarweed
<i>Distichlis spicata</i>	salt grass
<i>Eleocharis macrostachya</i>	spike rush
<i>Emmenanthe penduliflora</i>	whispering bells
<i>Encelia californica</i>	California encelia
<i>Erigeron foliosus</i>	daisy
<i>Epilobium canum</i>	California fuchsia
<i>Eriastrum spp.</i>	wooly-star
<i>Eriophyllum confertiflorum</i>	golden yarrow
<i>Eschsholzia californica</i>	California poppy
<i>Eremocarpus setigerus</i>	doveweed
<i>Eucrypta chrysanthemifolia</i>	eucrypta
<i>Filago spp.</i>	filago - variety
<i>Frankenia salina</i>	alkali-heath
<i>Galium angustifolium</i>	bedstraw
<i>Gilia spp.</i>	gilia
<i>Gnaphalium spp</i>	everlasting- variety
<i>Gutierrezia californica</i>	matchweed
<i>Hazardia squarrosa</i>	sawtooth goldenbush
<i>Helianthemum scoparium</i>	rush-rose
<i>Heliotropium curassavicum</i>	salt heliotrope
<i>Heterotheca grandiflora</i>	telegraph weed
<i>Holocarpha virgata</i>	graceful tarplant
<i>Hordeum californicum</i>	California barley
<i>Jepsonia parryi</i>	coast jepsonia
<i>Juncus bufonius</i>	toad rush
<i>Juncus mexicanus</i>	Mexican rush
<i>Lasthenia californica</i>	goldfields
<i>Lathyrus vestitus</i>	sweet pea
<i>Layia platyglossa</i>	tidy tips

ATTACHMENT 4

<i>Lessingia filaginifolia</i>	California aster
<i>Linanthus spp.</i>	linanthus
<i>Linaria canadensis</i>	blue toadflax
<i>Lomatium spp.</i>	lomatium
<i>Lonicera subspicata</i>	honeysuckle
<i>Lotus purshianus</i>	Spanish clover
<i>Lotus scoparius</i>	deerweed
<i>Ludwigia peploides</i>	water-primrose
<i>Lupinus bicolor</i>	miniature lupine
<i>Lupinus succulentus</i>	arroyo lupine
<i>Malvella leprosa</i>	alkali mallow
<i>Melica imperfecta</i>	tall melic
<i>Mirabolis laevis</i>	wishbone bush
<i>Mulenbergia rigens</i>	deergrass
<i>Nassella lepida</i>	foothill needlegrass
<i>Nassella pulchra</i>	purple needlegrass
<i>Navarettia hamata</i>	skunk weed
<i>Nemophila rotata</i>	baby blue eyes
<i>Osmadenia tenella</i>	osmadenia
<i>Osmorhiza brachypoda</i>	sweet cicely
<i>Paeonia californica</i>	California peony
<i>Pectocarya linearis</i>	pectocarya
<i>Pellaea mucronata</i>	bird's foot cliff-brake
<i>Penstemon spp.</i>	penstemen- variety
<i>Phacelia spp.</i>	phacelia - variety
<i>Pholistoma spp.</i>	fiesta flower
<i>Plagiobothrys spp.</i>	popcorn flower - variety
<i>Plantago ovata</i>	plantain
<i>Pluchea odorata</i>	salt marsh flea-bane
<i>Polygonum amphibium</i>	smartweed
<i>Polygonum lapathifloium</i>	willow weed
<i>Polypodium californicum</i>	California polypody
<i>Porophyllum gracile</i>	odorata
<i>Psilocarphus tenellus</i>	slender woolly-heads
<i>Rafinesquia californica</i>	chicory
<i>Ranunculus californicus</i>	buttercup
<i>Rorippa nasturtium</i>	watercress
<i>Salvia columbariae</i>	chia
<i>Sanicula bipinnatifolia</i>	purple sanicle
<i>Sarcocornia pacifica</i>	pickleweed
<i>Selaginella bigelovii</i>	spike-moss
<i>Senecio californicus</i>	butterweed

ATTACHMENT 4

<i>Sidalcea malvaeflora</i>	checker-bloom
<i>Silene laciniata</i>	southern pink
<i>Silene multinervia</i>	catchfly
<i>Sisyrinchium bellum</i>	blue-eyed grass
<i>Solanum parishii</i>	nightshade
<i>Stephanomeria diegensis</i>	wreath plant
<i>Suaeda esteroa</i>	estuary sea blight
<i>Suaeda taxifolia</i>	woolly sea blight
<i>Symphyotrichum sublatum</i>	slim aster
<i>Tauschia arguta</i>	southern tauschia
<i>Trichostema lanatum</i>	wooly bluecurls
<i>Trichostema lanceolatum</i>	vinegar weed
<i>Trifolium spp.</i>	clover-variety
<i>Verbena lasiostachys</i>	western vervain
<i>Viola pendunculata</i>	johnny jump-up
<i>Vitis girdiana</i>	wild grape
<i>Vulpia microstachys</i>	fescue

- Seed mixture composition will need to be determined based on a variety of conditions present at the site.
- Species suited to a variety of differing conditions including geographic location, soils, wetland versus upland, salinity, slope and aspect, disturbance levels, etc.
- Plants chosen by the architect shall be consistent with species natural to the adjacent area where possible.

ATTACHMENT 5

City of San Diego – Water and Sewer Development Review

CONSTRUCTION PLAN MINIMUM INTAKE QUALITY ASSURANCE/QUALITY CONTROL CHECKLIST

INSTRUCTIONS:

1. This form must be completed, signed and included with each set of construction plans submitted for review by Water and Sewer Development Review. Failure to complete or include the check list will result in the return of the design documents without review or approval.
2. The Design Engineer shall indicate compliance with, or deviation from, each of the items by placing a check mark in the appropriate column and initialing the item. All deviations must be addressed in the comments section at the end of the form. Attach additional information where requested.
3. The completed form shall be signed and dated in the indicated locations by the Engineer of Record.

CHECKLIST:

ITEM	Comply	Deviation	Initials
1. Obtain approval of the Sewer Study per Tentative Map condition for the project. (Attach copy of approval document.)			
2. Submit Plans for review only after the sewer study has been accepted.			
3. Show all existing sewer mains in public right-of-way and sewer lateral(s) adjacent to the project.			
4. Reference City drawing numbers, centerline information, dimensions, sizes and types for all existing sewer mains.			
5. Provide note on Improvement Plans: “All existing unused sewer laterals shall be plugged at property line by Contractor.”			
6. Provide a note on the Improvement Plans: “Prior to connecting to any existing sewer lateral, it shall be inspected using a closed-circuit television (CCTV) by a California Licensed Plumbing Contractor to verify the lateral is in good working condition and free of all debris.”			

ITEM	Comply	Deviation	Initials
7. Provide detail of manhole re-channelization showing invert elevations of all inlets and outlets and indicate the drop across the manhole (straight-through flow acceptable for 8" - 15" mains, 0.1' min. drop for 18" and larger mains, 0.2' min. drop for side inlet for all mains) (Ref. Subsection 2.3.6).			
8. Show invert elevations on profile view of all manhole inlets and outlets shown (straight-through flow acceptable for 8"-15" mains provided that the slope of main is the same on both sides of manhole. If not, then 0.1' min. drop for 18" and larger mains, and 0.2' min. drop for side inlet for all mains shall be required).			
9. Provide a 20-foot minimum width paved vehicular sewer access road with a turn-around to all manholes. Refer to City of San Diego Drawings FHPS-101 for requirements. The need for a turn-around may be waived when sewer access roads are 150 feet or less in length, have generous easements, and flat grades. Evaluations, if requested, will be reviewed on a case-by-case basis.			
10. Submit sewer easement drawings "B" sheet (minimum 15 feet wide easement for sewer pipe depths to 10 feet, plus 2 additional feet in easement width for every foot greater than 10 feet in depth).			
11. Provide a 20-foot minimum width vehicular sewer access easement from the public right-of-way to the existing/proposed sewer/general utility easement, where applicable.			
12. Provide a minimum 1-foot sand cushion or 6-inch sand cushion with 1-inch neoprene pad for all crossings where vertical clearance is 1 foot or less.			
13. Submit an Encroachment Maintenance and Removal Agreement (EMRA) for all private sewer laterals(s)/main(s)/water/other private utilities, private retaining wall, private storm drain, enhanced paving, landscape, irrigation, etc, within the sewer/water/general utility easement and/or public right-of-way.			
14. Provide sewer main abandonment table (See Subsection 2.7.5.1).			
15. Provide Sewer Notes, (See Subsection 2.7.3			
16. If the sewer main is located within Open Space or Environmentally Sensitive Lands (ESL), the DESIGN ENGINEER shall place a note on the Improvement Plans: "No shrubs greater 3 feet in height at maturity or trees shall be allowed within 10 feet of any public sewer main or lateral; no pressurized landscape irrigation mains or electrical or gas utilities shall be allowed within any sewer easement.."			

ITEM	Comply	Deviation	Initials
17. If the sewer main is located in environmental lands, the DESIGN ENGINEER shall place a Note on the Improvement Plans, limiting the placement of trees and shrubs per Subsection 3.2.3.4.			
18. Submit a copy of the subdivision/parcel map showing all sewer/access and/or general utility easements.			
19. Submit a copy of the CC&R's covering the maintenance and operation of the Private on-site Sewerage System.			
20. Call out all City Forces-provided Work Items on plans.			
21. Show all work to be done on plan/profile view and by legend items.			
22. Provide sewer lateral data table and drop to main: 1.2' for 8" main; 1.3' for 10"; 1.4' for 12"; and 1.8' for 15" with minimum 2% slope for all laterals.			
23. Provide sewer data table (See Subsection 2.7.5.2).			
24. For all private sewers which serve only one lot, label as "PRIVATE SEWER UNDER SEPARATE PLUMBING PERMIT" and add the following note to the plans: "ALL PRIVATE SEWER IMPROVEMENTS SHOWN ON THESE PLANS ARE FOR REFERENCE ONLY TO AVOID CONFLICTS AND TO SHOW CONNECTIONS TO PUBLIC SEWER LATERALS AND MAINS. ALL PRIVATE SEWERS SHOWN ON THESE PLANS SHALL BE INSTALLED UNDER SEPARATE PLUMBING PERMIT ISSUED BY THE CITY OF SAN DIEGO". Or, remove private sewer from public improvement plan, typical all sheets.			
25. For all private sewers which serve more than one lot, label as follows: "ALL PRIVATE SEWER MAINS, SEWER MANHOLES, SEWER LATERALS AND CLEANOUTS SHOWN ON THESE PLANS ARE TO BE BUILT TO PUBLIC STANDARDS AND SHALL BE INSPECTED BY THE CITY OF SAN DIEGO, ENGINEERING AND CAPITAL PROJECTS DEPARTMENT, FIELD ENGINEERING DIVISION". Typical all sheets.			

ATTACHMENT 6



THE CITY OF SAN DIEGO
PUBLIC UTILITIES
DEPARTMENT

City of San Diego On-Site Wastewater Treatment and Reuse Project Review and Permitting Guideline

February 13, 2015



Introduction

Purpose: The purpose of this document is to provide an overview of the submittal and permitting process for private on-site wastewater treatment and reuse projects in the City of San Diego. The project's source of influent, the treatment and reuse systems shall all be located on the same site and shall be under the control of the site owner. Projects that include sewer mining (extraction of wastewater from a publicly owned sewer) for plant influent shall not be considered under these guidelines. A project which included sewer mining would be in conflict with some of the City's sewer and water bond covenants and could impact the ability of the City to finance sewer and/or water projects.

Background: The document was prepared by the Public Utilities Department with input from numerous additional departments. Stakeholder input was requested through a working group meeting held on August 19, 2014 where in the draft document was presented and discussed. Comments on the draft document were submitted and addressed.

Regulatory Responsibility: The regulatory responsibility for an on-site wastewater treatment and reuse project is divided among several governmental entities. In general, the regulatory responsibilities are as presented below:

City of San Diego: Facility compliance with development regulations and building codes, recycled water run-off and for industrial waste discharge permit for any discharges into the publicly owned wastewater collection system.

State of California Water Resources Control Board, Division of Drinking Water: Treated water quality requirements, treatment process approval and monitoring of treatment performance.

County of San Diego Department of Environmental Health: Permitting and monitoring of recycle water application sites.

Organization: This document is divided into 8 sections as follows:

- Introduction
- Step 1 – Project Preliminary Review
- Step 2 – Final Project Application Review
- Step 3 – Detailed Design
- Step 4 – Project Construction
- Step 5 – Start-Up
- Step 6 – Full Operation
- Useful Reference Documents and Web Addresses

Abbreviations, Web Addresses and Telephone Nos.

DSD: City of San Diego Development Services Department
www.sandiego.gov/development-services/ 619-446-5000

- PUD: City of San Diego Public Utilities Department
www.sandiego.gov/publicutilities/ 619-515-3500
- TSWD: City of San Diego Transportation and Storm Water Department
www.sandiego.gov/tsw/ 619-235-1000
- RWQCB: San Diego Regional Water Quality Control Board
www.waterboards.ca.gov/sandiego/ 619-516-1990
- SWRCB: State Water Resources Control Board-Division of Drinking Water
www.waterboards.ca.gov/drinking_water/
- DEH: San Diego County Department of Environmental Health
www.sandiegocounty.gov/deh/ 619-607-8351

Disclaimer: This document is meant to be an aid to the Project Owner and staff of the City of San Diego in the review and permitting process of On-Site Wastewater Treatment and Reuse systems. It cannot be relied upon to be all inclusive, complete or to be a representation of the State, County or City laws, regulations or policies.

Step 1 – Project Preliminary Review

Project Owner:

- A. Prepares and submits the Project Preliminary Review Application with initial data to DSD.
- B. Provides initial project application to State and County Regulatory Agencies as required.
- C. Provides required initial fee deposits to establish a project review accounts with City and Regulatory Agencies as they work under a “fee for service basis”.

City:

- A. DSD notifies owner of required initial fee deposit and on receipt establishes project review account and distributes the Project Preliminary Review Application to all relevant City Departments for review
- B. Departments review and provide comments to DSD concerning the following
 - a. DSD: Zoning Requirements, determination of required environmental documentation.
 - b. PUD: Impact on downstream City sewer facilities, applicable industrial waste discharge requirements.
 - c. DSD: potential impacts on local storm water runoff quality.
- C. DSD compiles and transmits comments to Project Owner.

Regulatory Agency:

- A. Notifies Project Owner of required initial fee deposit and on receipt, establishes review account.
- B. Reviews and provide comment on the initial project notification.
- C. SWRCB determines product water quality requirements based on proposed uses of recycled water.

Step 2 – Final Project Application Review

Project Owner:

- A. Prepares Title 22 Engineering Report in compliance with SWRCB requirements (See Note 1).
- B. Prepares environmental documents to comply with the California Environmental Quality Act (CEQA), if required.
- C. Includes an Appendix in Engineering Report to address City comments and requirements.
- D. Submits Engineering Report to DSD and RWQCB, SWRCB, DEH.
- E. Addresses comments from City and Regulatory Agencies, updates and submits Final Engineering Report as needed.

City:

- A. DSD distributes the Draft Engineering Report to relevant City Departments for review and comment:
 - a. DSD: Zoning Requirements, information usually included in a standard sewer study and environmental documentation
 - b. PUD: Impact on downstream City sewer facilities, applicable industrial waste discharge requirements.
 - c. DSD: Impact on local storm water runoff quality.
- B. DSD compiles comments and transmits them to the Project Owner. Provides a copy to the Regulatory Agencies.
- C. DSD reviews and distributes to PUD the final updated Engineering Report, environmental documentation and comment responses. DSD approves City portions of Engineer Report and environmental documentation.

Regulatory Agencies:

- A. RWQCB, SWRCB and DEH review the Engineering Report and environmental documentation for compliance with their requirements. Submits comments to the Project Owner. Generally RWQCB will review the Title 22 Engineering Report and DEH will review the Title 22 Report and plans for irrigation and cooling towers.

Note 1: Useful references include: “Guidelines for the Preparation of an Engineering Report for the Production, Distribution and Use of Recycled Water” (March 2001), by the California Department of Health Services (now the State Water Resources Control Board-Division of Drinking Water); “Alternative Treatment Technology Report for Recycled Water (September 2014) by California State Water Resources Control Board; and “Recycled Water Plan Check and Inspection Manual” (2001) by Department of Environmental Health.

STEP 3 – Detailed Design

Project Owner:

- A. Prepares detailed design documents (drawings, specifications, & Operation Maintenance manuals, etc.) based on the approved Engineering Report and environmental document, (approval from all agencies) and all applicable rules and regulations.
- B. Submits signed and sealed documents to DSD and other agencies for the plan check and issuing of the required permits (Grading and Right of Way, Building/Structural, Electrical, Plumbing, Mechanical and Signs).
- C. Addresses review comments and updated documents as necessary to achieve approval.
- D. Prepares and pays for all permitting fees and inspection deposit.
- E. Prepares and submits an application for a Waste Discharge Permit to RWQCB.

City:

- A. DSD receives and distributes the design documents to relevant City Departments for review & comment.
 - a. DSD: Code compliance
 - b. PUD: Cross connections and public utility interface requirements.
 - c. DSD: Storm water impacts
- B. DSD compiles comments and transmits them to the Project Owner. Provides a copy to the Regulatory Agencies.
- C. DSD and PUD review updated design documents and comment responses. DSD approves portions of design under City authority.
- D. Based on approved design documents from City and Regulatory Agencies, DSD issues needed permits for construction: Grading and Right of Way, Building/structural, Electrical, Plumbing, Mechanical, Signs.

Regulatory Agencies:

- A. Review project design documents to ensure conformance with approved Engineering Report and environmental documentation and transmits comments to Project Owner.
- B. Provide approval of design to project owner. Notifies DSD of Approval.
- C. Reviews waste discharge permit application from Project Owner.

Step 4 – Project Construction

Project Owner:

- A. Constructs the facilities according to the approved plans, specifications and permit requirements.
- B. Notifies City and Regulatory Agencies of construction progress.
- C. Requests and/or performs inspections as required by the permits.
- D. Tests equipment and systems for proper function.
- E. Informs City and Regulatory Agencies of construction changes and initiates review.
- F. Corrects all defects and non-conforming work.
- G. Provides a Construction Certification Letter to all agencies at completion stating that all facilities are constructed in accordance with the approved Engineering Report, permit requirements and approved plans and specifications.
- H. Performs and passes cross connection testing by certified specialist.

City

- A. DSD performs inspection. Notifies Project Owner of non-conforming work.
- B. DSD reviews Construction Certification Letter.
- C. DSD issues Final Inspection approval.

Regulatory Agencies:

- A. Perform inspections and certification reviews
- B. Provide Construction Completion Certificate.

STEP 5 – Start-up

Project Owner:

- A. As a prerequisite for initiating start-up, the facility operation and maintenance manuals and staffing must be approved by the Regulatory Agencies. In addition, the potable water backflow protection testing has been complete by PUD and the Temporary Certificate of Occupancy is issued by DSD.
- B. Initiates operation of the facility.
- C. Discharges recycled water to sewer until it consistently meets the standard required by the Regulatory Agencies.
- D. Makes necessary modifications if, required, to achieve permitted recycled water quality.
- E. Performs process and waste discharge sampling and testing in accordance with the Regulatory Agency and City requirements. Provides monthly reports.
- F. Initiates operation of the recycled water distribution systems after consistently meeting water quality standards and approval by Regulatory Agency.

City:

- A. PUD issues a short term Industrial User Discharge Permit allowing for start-up services. Term of permit will match Regulatory Agency permitted duration of start-up services.
- B. PUD reviews plant operating records and performs sampling and analysis of wastes discharged into the City sewer system for compliance with discharge permit and for initial billing parameters
- C. PUD issues a 4-year Industrial User Discharge Permit based approved successful commissioning by Regulatory Agencies. Permit will require monthly flow reporting of untreated wastewater, recycled water and sludge and COD and TSS analysis of sludge.

Regulatory Agencies:

- A. Issue short term start-up permit.
- B. Monitor and review Commissioning activities and reports from the Owner.
- C. Perform inspections of facility, recycled water system and application sites
- D. Issue approval for full operation when all requirements are met consistently for a period specified by the regulatory agency.

STEP 6 – Full Operation

Project Owner:

- A. Operates plant in accordance with permits and regulations.
- B. Prepares and submits operating reports as required by Regulatory Agencies and PUD.

City:

- A. PUD prepares invoices for discharges to the public sewer.
- B. PUD performs inspections and sampling to confirm Industrial Waste Discharge compliance.

Regulatory Agencies:

- A. Monitor facility operations and review operating reports.
- B. Perform inspections and sampling to confirm compliance.

Useful Reference Documents and Web Addresses

State Water Resources Control Board

- Preparation of an Engineering Report for the Production, Distribution and Use of Recycled Water (March 2001)
- Alternative Treatment Technology Report for Recycled Water (September 2014)
- http://www.waterboards.ca.gov/drinking_water/certlic/drinkingwater/RecycledWater.shtml

State Department of Public Health (Currently the State Water Resources Control Board, Division of Drinking Water)

- California Health Laws Related to Recycled Water
<http://www.cdph.ca.gov/certlic/drinkingwater/Documents/Recharge/Purplebookupdate6-01.PDF>

San Diego County Department of Environmental Health

- Recycled Water Plan Check and Inspection Manual (DEH 2001 Edition)
http://www.sandiegocounty.gov/content/sdc/deh/lwqd/lu_recycled_water.html

City of San Diego

- Industrial User Discharge Permit and Application
<http://www.sandiego.gov/mwwd/enviroment/iwcp/significant.shtml>