

**STANDARDS
FOR
LANDSCAPE IRRIGATION SYSTEMS**



JANUARY 2008 EDITION



TABLE OF CONTENTS

Introduction..... page 1

General

1. Scope of Work page 2
2. Quality Assurance page 2
3. Submittals page 3
4. Site Conditions page 3
5. Owner or Representative page 4
6. Regulations page 4
7. Alternate Materials page 4

Design

1. Sprinklers page 5
2. Pipe page 5
3. Zoning page 6
4. Controls page 6
5. Pressure Control page 6
6. Winterizing page 7
7. Low Volume / Micro Irrigation page 7
8. Control Wire page 7

Materials

1. Sprinklers page 8
2. Control Valves page 8
3. Isolation Valves page 8
4. Controllers page 8
5. Wire page 9
6. Backflow Prevention Devices page 9
7. Pipe – Polyethylene page 9
8. Pipe - Poly Vinyl Chloride page 9
9. Fittings page 10
10. Cement and Primer page 10
11. Valve Boxes page 10
12. Sleeving page 10
13. Hydraulic Controls page 10

Installation

1. Excavation and Backfill page 11
2. Pipe page 11
3. Valves and Valve Boxes page 12
4. Sprinklers page 12
5. Wire page 13
6. Backflow Prevention page 13
7. Controller page 13
8. Turf Valves / Quick Coupling Valves page 14
9. Sleeving page 14

Site Maintenance page 15

Inspection and Testing

1. Inspection page 16
2. Testing page 16
3. Deficiencies page 16

Installation Detail Drawings

Figure 1 Shrub Spray on Riser page 17
Figure 2 Turf Rotary Head or Pop Up Spray Headpage 18
Figure 3 Quick Coupler Valve page 19
Figure 4 Globe Valve - Standard Installation page 20
Figure 5 Controller – Wall Mount page 21
Figure 6 Residential Point of Connection page 22
Figure 7 As-Built Plans Minimum Recommendations page 23

INTRODUCTION

The following Standards for Landscape Irrigation Systems replace the previous publication of March 1997. They have been developed by the Irrigation Industry Association of British Columbia to reflect the current *minimum* Standards for the industry and to provide guidance to its members as a benchmark for their performance. The principles embodied in these Standards apply to all landscape irrigation systems but the special circumstances of some owners or installations may require the development of more customized specifications related to the project.

The use of these Standards is intended to encourage efficient and responsible water management and result in irrigation systems that are economical, practical, and sustainable.

Owners, designers, and installers of these systems are responsible for the use of a precious and finite resource to maintain healthy and functional landscapes. Accepted industry practice reflects these goals.

The Irrigation Industry Association of British Columbia accepts no liability arising from the use of these Standards in contractual relationships between parties to an irrigation project.

GENERAL

1. Scope of Work

- (a) Supply and install the components required for an automatic irrigation system to provide supplemental water to the intended landscape efficiently and uniformly.
- (b) Obtain or prepare a scaled design of the proposed irrigation system which meets IIABC Design Standards.
- (c) Obtain properly informed agreement from the owner's representative as to the inclusion or not of desirable features in the design which exceed IIABC Design Standards and/or are site specific.

2. Quality Assurance

- (a) All irrigation work shall be done by a suitably experienced and qualified irrigation contractor, having trained and competent personnel adequate for the scope of work. Utilizing Staff certified by the IIABC in such disciplines as Certified Irrigation Technician (level 1 or 2), Certified Designer (Commercial or Residential), Certified Irrigation Auditor, etc. are recommended.
- (b) The contractor shall be a member in good standing of the Irrigation Industry Association of B.C. and have met the qualification standards currently applied to contractors by that organization.
- (c) A written guarantee of the installed system shall be provided to the owner covering workmanship and materials for a minimum of one year.

3. Submittals

- (a) A suitably scaled as built drawing shall be provided. All components of the irrigation system shall be shown as installed, with clear measurements from an identifiable reference point to the location of the controller and its circuit breaker, master valve, zone control valves, main water connection, blow out connection, pump and its electrical connections, and any other similar features. Please see Figure 7 for details.
- (b) Provide a manual containing operating and maintenance instructions for all components of the system including but not limited to a zone map or list of zones and the areas they cover.
- (c) Provide clear instructions for operating the irrigation system "in season", showing the relative timing differences between zones of different precipitation rates, and a schedule of run times suggested for various weather conditions. Division of the system into "Hydrozones", or areas with different water requirements, whether based on gardens/grass, sun exposure, drainage patterns, or distinct areas is encouraged.
- (d) Provide any special tools as provided by the manufacturer for day to day servicing of the irrigation equipment installed.
- (e) Provide a base irrigation schedule indicating when and how much to irrigate, by zone, for the system installed. Indicate a source of local evapotranspiration data with clear instructions on how to alter the schedule reflecting changing ET values appropriately.

4. Site Conditions

- (a) Verify and mark the location of all on site utilities required by the irrigation system.
- (b) Verify and mark the location of all buried cables, conduits, pipes, etc., prior to any trenching.
- (c) Adjust the design as necessary, together with the owner's representative, to suit existing site conditions and grades before proceeding with the work.
- (d) Protect from damage as necessary, existing landscape features, plant material structures, this work in progress, and the work of other trades.
- (e) Ensure that sequencing of this work is carried out in coordination with the work of other trades and that sleeves are installed when appropriate.

5. Owner or Representative

- (a) Prior to commencement of any involvement with an irrigation project, identify the person or persons properly authorized to make project decisions.

6. Regulations

- (a) Obtain all permits and licenses applicable to the work to be done.
- (b) Ensure that there is compliance with the relevant codes and regulations both in the design and during the conduct of the work involved in the project.

7. Alternate Materials

- (a) The formal approval of the owner's representative is required prior to the use of materials that are different from those shown in the design.
- (b) Alternate materials must match the original materials in performance, flow, pressure loss, and other important characteristics so as not to compromise the intent of the design.
- (c) The materials must all remain compatible. When changing from one product to another the flow from all the sprinklers must be recalculated to confirm pipe is still sized at 5 ft/sec.
- (d) The alternate materials proposed must be applied according to their manufacturer's recommendations.

DESIGN

An irrigation system must apply a consistent, even, measurable amount of water to the landscape over a period of time. It is necessary that the system design consider water cost and conservation, long term durability and maintenance cost, safety issues, aesthetic issues, and site specific requirements. The relative importance of these considerations will vary from project to project and require the attention of a qualified and experienced designer. An IIABC Certified Designer of the appropriate discipline is recommended. The design will incorporate the following:

1. Sprinklers

- (a) The maximum spacing shall be equal to the radius of throw (head to head) with appropriate allowance for wind if applicable.
- (b) The selection of pop-up or riser style sprinklers must consider safety, maintenance, risk of vandalism, and appearance on the site.
- (c) Pop-up or riser height must consider the related plant material, its growth potential, interfering landscape features, and arrive at a solution which provides optimum coverage for as long as possible.
- (d) All sprinklers must be suitably adjustable and located so as to keep the water within the landscaped area and minimize overthrow.
- (e) Sprinklers with built in check valves must be used when low head drainage is apparent to eliminate wasted water and reduce erosion.
- (f) Sports fields and public parks shall be equipped with sprinklers with rubber covers in turf areas.
- (g) Pressure compensating devices (heads, screens, or valves) are recommended to increase efficiency and water conservation.

2. Pipe

- (a) The velocity of flow in piping must not exceed 5 feet per second.
- (b) Pipe routing must take site elevation changes into consideration to minimize low head drainage.
- (c) Selection of the strength and / or flexibility of the pipe material and its installation criteria must consider site specific requirements such as frost, traffic, soil depth, soil composition, soil quality, etc.
- (d) Pipe sizing and routing must include pressure loss calculations to ensure that the required pressure will be delivered under all circumstances and that pressure variation within the lateral is at a minimum.

3. Zoning

- (a) All sprinklers grouped into a zone must have the same precipitation rates. Rotating style heads should take into account arcs of coverage to ensure matched precipitation.
- (b) The potential for low head drainage must be minimized for each zone.
- (c) The areas of the landscape that have different water requirements (different hydrozones) must be identified and a determination made as to the significance of these differences and whether they require separate zoning. The type of plant material and its location on site (sun exposure and natural drainage), and varying soil and slope conditions must be considered.
- (d) The pressure variation within each zone from the first to the last head must not exceed 15%.

4. Controls

- (a) Controllers must be C.S.A. / C.U.L. approved, suitable for their mounting location, and sufficiently flexible to allow for and encourage optimum operation of the designed system in all circumstances.
- (b) Moisture sensors or other "rain off" devices are a desirable enhancement of any irrigation system and are recommended for effective water management.
- (c) Valves must meet the pressure and flow requirements of the zone being controlled.
- (d) "ET Based" controllers or "Smart Controller" products with significant water savings are encouraged.
- (e) Indoor rated controllers should only be mounted indoors. Indoor rated controllers can only be mounted outdoors in suitable weather-tight enclosures.

5. Pressure Control

- (a) The design must include suitable regulation of the pressure throughout the irrigation system utilizing such devices as pressure compensating valves, heads, and screens.
- (b) The pressure at every head must be within the range recommended by the manufacturer of the head/nozzle combination being used.

6. Winterizing

- (a) The system design must make the water connection and all the system components safe from winter freezing damage.
- (b) A suitable and convenient blow out point and connection is the most desirable method of purging the system of water using a suitably sized air compressor.
- (c) Automatic drain valves are not recommended.

7. Low Volume / Micro Irrigation

- (a) Any low volume irrigation included in a system must be separately zoned and valved independently from rotors or spray heads.
- (b) Filtration and pressure control as recommended by the manufacturer of the low volume devices must be provided together with suitable controller capabilities.
- (c) Connect (loop) ends of the individual laterals to improve system uniformity and limit contamination if drip tubing is damaged.
- (d) Use air-vacuum relief valves to minimize injection of dirt or other contaminants into the emitters.
- (e) Wherever possible use drip irrigation to increase irrigation efficiency.

8. Control Wire

- (a) Control wire must be sized to the length of its run using the recommendations of the manufacturer of the zone control valves being wired.
- (b) A spare wire should be available at each valve manifold.

MATERIALS

1. Sprinklers

- (a) All sprinklers shall be in new condition with the size, manufacturer, and features as shown in the design or approved equal (see GENERAL 7.)
- (b) The relevant manufacturer's recommendations must be followed in the selection and application of each sprinkler being used.

2. Control Valves

- (a) All control valves shall be in new condition with the size, manufacturer, and features as shown in the design or approved equal (see GENERAL 7.)
- (b) The relevant manufacturers recommendations must be followed in the selection and application of each control valve being used.

3. Isolation Valves

- (a) All isolation valves shall be in new condition with the size, manufacturer, and features as shown in the design or approved equal (see GENERAL 7.)
- (b) Valves 1/2" through 2 1/2" may be ball or gate valves while those larger shall be operated by butterfly valves.

4. Controllers

- (a) All controllers shall be in new condition with the size, manufacturer, and features as shown in the design or approved equal (see GENERAL 7.)
- (b) All controllers shall be C.S.A. / C.U.L. approved for use in the mounting location selected.

5. Wire

- (a) All power and control wiring and its associated components shall conform to local codes being used.
- (b) All wire shall be sized and specified as shown in the design.
- (c) Line voltage wire shall be C.S.A. approved either NMWU or TWU. Line voltage wire should be installed by a certified electrician with the requisite qualifications.
- (d) Approved multi-conductor control wire may be used if specifically manufactured for use as direct burial irrigation wire.
- (e) White wire shall only and always be used as the common wire.
- (f) All connectors shall be approved for water tight application and assembled according to the manufacturer's recommendations.
- (g) No wire smaller than 18 gage shall be used.

6. Backflow Prevention Devices

- (a) All backflow prevention devices shall be in new condition with the size, manufacturer, and features as shown in the design or approved equal (see GENERAL 7.)
- (b) All devices used must be approved for the application and must meet or exceed the local plumbing requirements.

7. Pipe - Polyethylene

- (a) All pipe shall be in new condition, extruded from virgin materials and continuously and permanently marked with the manufacturers name, material, size, and pressure rating.
- (b) All pipe must be Series rated for a pressure equal to or greater than the maximum water pressure to be encountered in the irrigation system.

8. Pipe - Poly Vinyl Chloride

- (a) All pipe shall be in new condition, extruded from virgin materials and continuously and permanently marked with the manufacturer's name, material, size, and pressure rating
- (b) A minimum of Series / Class 315 pipe shall be used in 1/2", Series 200 in 3/4" and 1", and Series 160 in 1 1/4" and larger.

9. Fittings

- (a) Fittings for P.V.C. pipe shall be Schedule 40 P.V.C. suitable for solvent welding or threaded connections.
- (b) Fittings for Polyethylene pipe may be compression style or insert fittings with strength at least equal to the pipe used complete with all stainless steel clamps.
- (c) Nipples shall be Schedule 80.
- (d) Threaded connections of P.V.C. to metal shall have male threads on the P.V.C. and female threads on the metal.
- (e) Polyethylene barb fittings and marlex street ells are acceptable for use with ½ inch swing pipe or triple swing joint assemblies.

10. Cement and Primer

- (a) The cement and primer combination shall be as recommended by the manufacturer to be suitable for the materials and application, when used as directed, and meet local codes.

11. Valve Boxes

- (a) All valve boxes shall be in new condition and of the size and type as shown in the design or approved equal (see GENERAL 7.)

12. Sleeving

- (a) Sleeving material shall be Series 160 P.V.C. unless the circumstances of its installation require a stronger material to ensure its survival during ongoing construction activity by other trades.
- (b) Sleeving shall be sized to be twice the size of the pipe being protected if lateral line and three times the size if main line.

13. Hydraulic Controls

- (a) Hydraulic control lines and the associated water filtration equipment shall be as recommended by the manufacturer of the control devices being used.

INSTALLATION

Prior to beginning the installation, the contractor should verify the site specific design information, including water pressure and flow, the area for each hydrozone, grading and slopes, utility locations, and any other important features. The proposed system should be laid out and sprinkler locations flagged. The relative lack of flexibility in pipe, valve, and particularly head placement will require coordination with landscape planting locations to minimize conflict, damage, and avoid compromising the irrigation design.

1. Excavation and Backfill

(a) The following coverage to finished grade is required over the piping:

Residential and Commercial Landscape	8 to 12 inches (200 to 300 mm)
Public Parks and Sports Fields	12 to 16 inches (300 to 400 mm)
Sleeving under Roadways	18 to 24 inches (450 to 600 mm)
Sleeving in Landscape	Depth of Pipe
Piping on Slab	If required depth is not available, pipe is to be on top of the filter fabric above the drain rock or voiding material.

- (b) All trenches shall be as straight as possible with a level, uniform slope to the bottom.
- (c) Backfill trenches in 4" (200 mm) layers, tamping firmly to ensure that the compaction of the trench is equal to the surrounding undisturbed areas.
- (d) Backfill material shall be free of rocks and / or other unsuitable materials which could damage the pipe or create unusual settlement problems.
- (e) Backfill material around the swing joints and under the heads shall be of a suitable type so as to allow appropriate movement under impact.
- (f) Trenches shall be at least 12 inches (300 mm) away from paving stone or other hard surfaces to avoid undermining such surface or its edge retention.

2. Pipe

- (a) Visually inspect each pipe prior to installation, removing any dimpled or otherwise damaged sections.
- (b) Lay the pipe in a straight line between fittings, placing it on firm soil at all points in the trench.
- (c) Multiple pipes may occupy the same trench provided that a minimum of 2 inches (50 mm) horizontal clearance can be maintained and the pipes are all on the same plane.

- (d) All solvent welding is to be done in careful compliance with the manufacturers recommendations with particular attention to cleanliness, air temperature, moisture, and curing time. Excess cement must be removed from all joints.
- (e) All polyethylene insert fittings in 1 1/2" and 2" sizes shall be double clamped.
- (f) Thrust blocking is required for gasketed pipe 3" and larger.
- (g) As the pipe layout in the design is diagrammatic, care must be taken during the installation to size the pipe to keep the velocity of flow at 5 feet per second.

3. Valves and Valve Boxes

- (a) All valve boxes shall be installed flush with finished grade and located in shrub areas where possible.
- (b) All valves shall be installed vertically and centered in the box so as to be easily accessible for servicing.
- (c) All valve boxes shall be installed with adequate clearance above the pipe and on a firm base so as not to contact the pipe with settlement or upon being depressed.
- (d) Valve boxes shall be supported and of a type of material such as to be able to support the weight of expected traffic.
- (e) Minimum valve box size recommendations are:

910	-	One 1 1/2" or Two 1 " valves
1419	-	Two 1 1/2" or Three 1" valves
1220	-	Three 1 1/2" or Four 1" valves

4. Sprinklers

- (a) All pop-up sprinklers shall be connected to the pipe by an adjustable swing joint assembly that is sized to meet the flow requirements of the sprinkler.
- (b) A swing joint assembly shall be either a P.V.C. triple swing joint consisting of a Schedule 40 street elbow (MIPT x FIPT), a Schedule 80 nipple, and two Schedule 40 street elbows at the head end, or a polyethylene swing pipe with a barb by pipe thread elbow at each end; the end that connects to the base of the sprinkler must have an extra threaded street elbow.
- (c) All sprinklers with an inlet size larger than 3/4" shall use a P.V.C. triple swing joint assembly or a pre-assembled swing joint only.
- (d) Swing joint assemblies for valve-in-head sprinklers shall have Acme threads and an O ring sealing mechanism.

- (e) The bottom street elbow of the swing joint assembly shall be connected to an outlet on the side of the lateral line pipe and the nipple shall be of sufficient length to be installed at an approximate 45 degree angle when the sprinkler is mounted at finished grade. A similar alignment is required if swing pipe is used, with a minimum length of polyethylene tubing of 12".
- (f) All pop-up sprinklers shall be installed flush and level with the finished grade and not higher than any adjoining hard surface from which there must be at least a 2" separation to allow for edging.
- (g) All stationary shrub risers shall be installed with two P.V.C. street elbows connected to the side of the lateral line pipe and a Schedule 80 nipple that is long enough to suit the plant material.
- (h) All piping must be thoroughly flushed prior to the installation of sprinklers and nozzles. Large zones will require progressive flushing.

5. Wire

- (a) All wiring shall be installed to meet local electrical codes.
- (b) All wiring shall be protected by being bundled and taped at 10 foot intervals and installed beneath the irrigation piping or in appropriately sized conduit if run independently.
- (c) All wire splices must be contained in a valve box.
- (d) Sufficient extra wire shall be left in each valve box such that the splice may be lifted 12" above grade. Extra wire to be neatly coiled.
- (e) White wire shall only be used as the common wire and other colors used shall be consistent from valve to controller.

6. Backflow Prevention

- (a) Backflow prevention assemblies shall be installed according to the local plumbing code and the Cross Connection Control Manual adopted by the B.C.W.W.A.
- (b) All cross connection control devices installed must be sized to accommodate the flow requirements present, and successfully tested after installation by an active certified Cross Connection Control Specialist.

7. Controller

- (a) The controller shall be firmly mounted at approximate eye level with all wiring done in the controller or an approved junction box.
- (b) Zones shall be wired in a logical sequence and unless they can be clearly described, a scaled site plan shall be mounted next to the controller with each zone clearly outlined.
- (c) The installation of any rain / moisture sensing equipment shall be noted on the controller and the location of the controller's circuit breaker indicated unless obvious.

8. Turf Valves / Quick Coupling Valves

- (a) All turf valves / quick coupling valves installed in the landscape shall be mounted on a suitably sized swing joint, either solidly supported by clamping to an angle iron stake or the last two fittings attached to the quick coupling valve shall be a 90 degree galvanized/brass elbow and a galvanized/brass nipple.

9. Sleeving

- (a) All sleeving in soil shall be installed and backfilled with the same considerations for protection of the material as if it were water pipe. Compaction shall be to the same standard as the adjoining undisturbed soil and the sleeves shall project at least 12" on either side of the hard surface being crossed.
- (b) Sleeving being installed across roads or driveways for later use shall have the necessary pipe installed at the same time with each end elbowing to at least 36" above grade.
- (c) When it is not possible to install sleeving, the water pipe shall be either Schedule 40 P.V.C. or Series 160 Polyethylene.

SITE MAINTENANCE

- 1) The job site shall be kept in a neat, clean, and orderly condition at all times during the installation process.
- 2) All scrap and excess materials are to be regularly removed from the site and not buried in trenches.
- 3) Trenching, laying pipe, and backfilling shall be continuous so that the amount of open trench at the end of each work day is minimized. Any open trench or other excavations shall be barricaded and marked with high visibility flagging tape.



INSPECTION AND TESTING

1. Inspection

- (a) Upon completion of the irrigation system installation, all pressure regulation, arcs, distances of throw, sprinkler locations and height, controller zones, etc., must be adjusted so as to optimize the operation of the system and make it ready for inspection and testing
- (b) Inspection will be carried out by the owner's representative to ensure that the work has been done in a neat and workmanlike fashion, and meets the intent of the installation standards previously agreed upon, in all important aspects.

2. Testing

- (a) The test will require that the system be operated sequentially with the controller, in the presence of the owner's representative.
- (b) The purpose of the test is to ensure that the system adequately covers the landscape to be irrigated and meets the design criteria previously agreed upon.
- (c) There are no circumstances under which the system main line should be subjected to the application of compressed air as a static pressure test. This is a hazardous and unnecessary procedure. The water meter will detect leakage of any significance and if absent and leaking is suspected, hydrostatic pressure testing can be considered.

3. Deficiencies

- (a) Any deficiencies noted during the inspection and testing will be rectified promptly and signed off by the owner's representative.
- (b) Any disputes arising from the use or implementation of these standards may be referred to the IIABC for arbitration or recommendations.

INSTALLATION DETAIL DRAWINGS

The following drawings are provided for reference only. Individual project requirements may dictate differences in installation procedure that are not identified here.

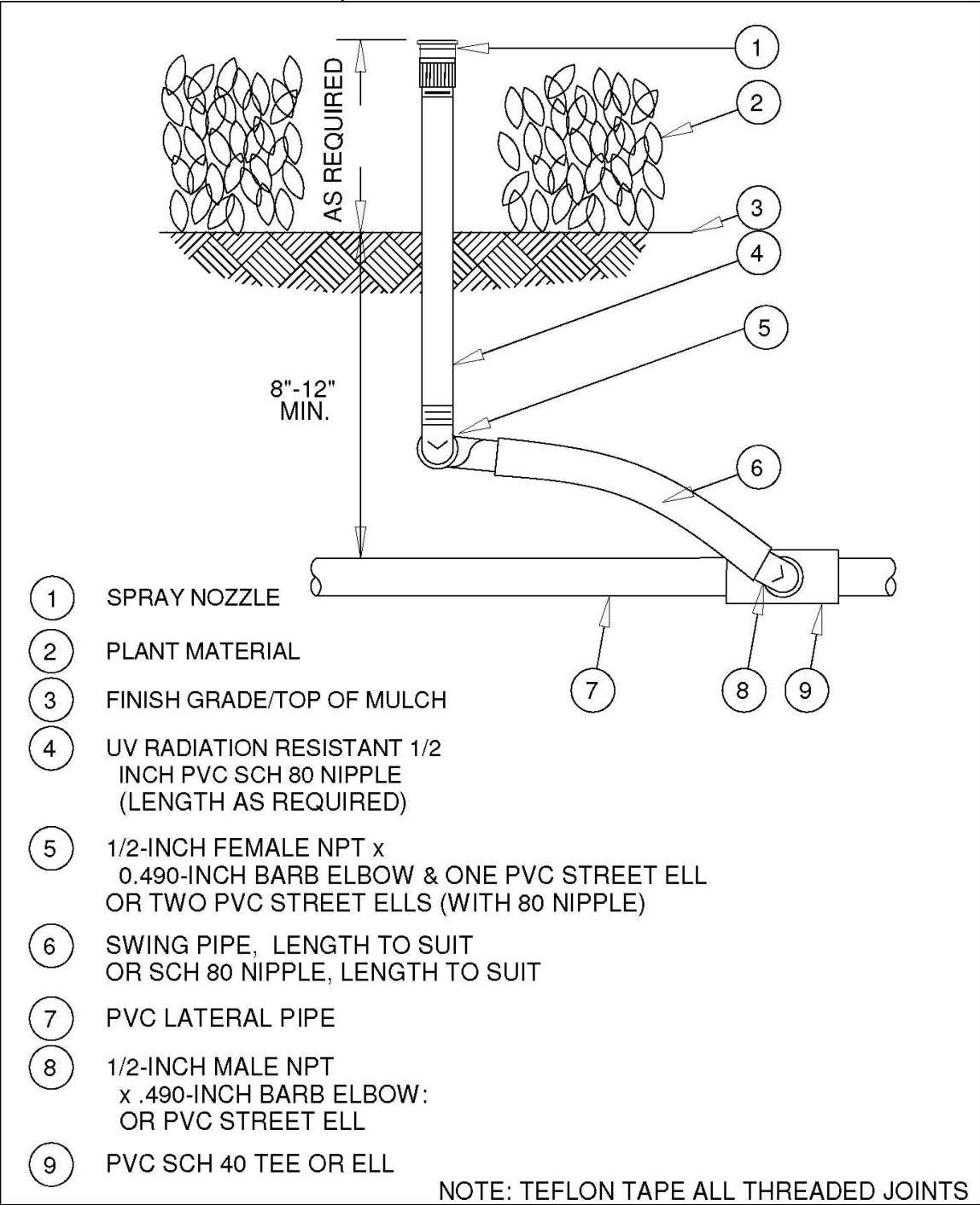

Figure 1 Shrub Spray on Riser

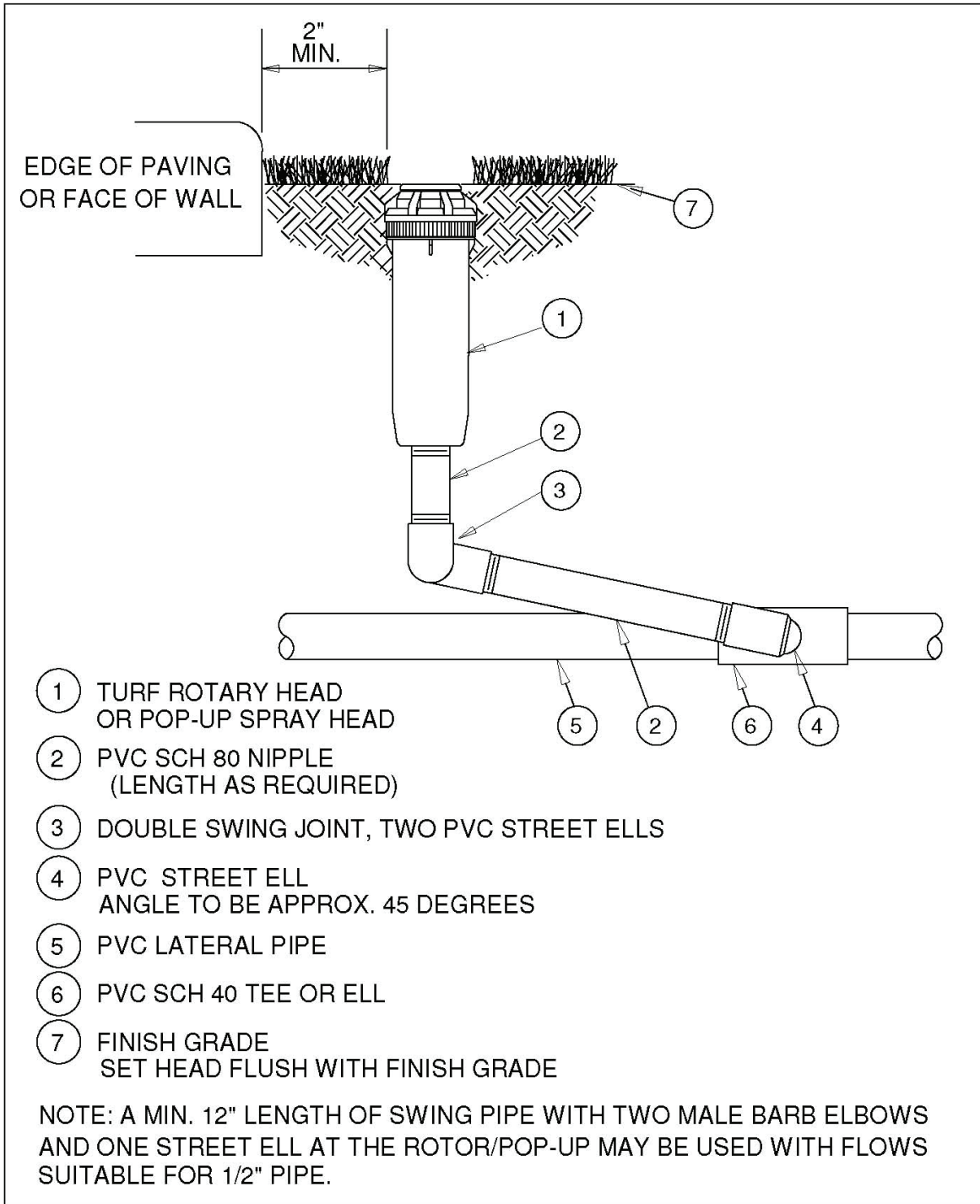
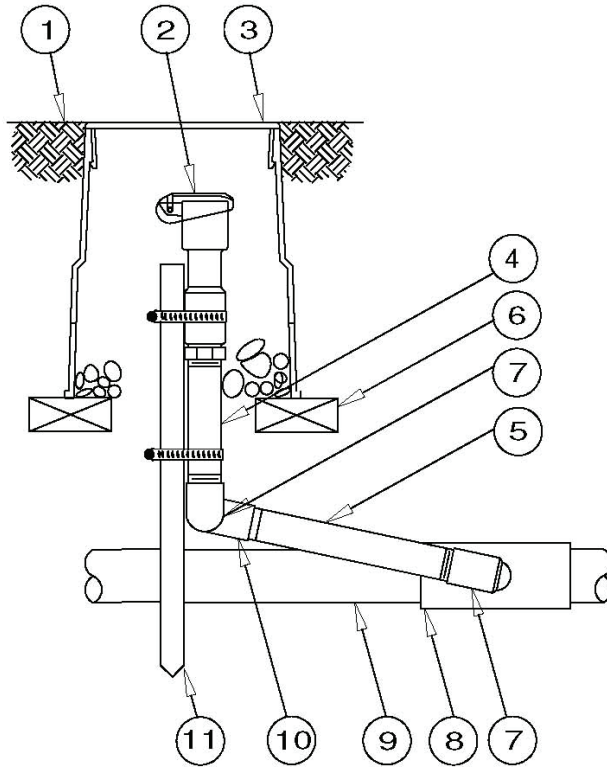

Figure 2 Turf Rotary Head or Pop-up Spray Head



- | | |
|---|---|
| ① FINISH GRADE/TOP OF MULCH | ⑦ PVC SCH 40 STREET ELL |
| ② QUICK-COUPLING VALVE | ⑧ PVC SCH 40 TEE OR ELL |
| ③ VALVE BOX WITH COVER
SIZED FOR THE VALVE KEY TO BE USED | ⑨ PVC MAINLINE PIPE |
| ④ GALVANIZED VERTICAL NIPPLE | ⑩ PVC SCH 40 ELL |
| ⑤ PVC SCH 80 NIPPLE @ 45 DEGREE ANGLE
(LENGTH AS REQUIRED) | ⑪ 30" X 1" GALVANIZED ANGLE IRON
STAKE WITH HEAVY DUTY
GALVANIZED FASTENERS
(2 REQUIRED) |
| ⑥ BRICK (1 OF 2) | |

NOTE:

1. FURNISH FITTINGS AND PIPING NOMINALLY SIZED IDENTICAL TO NOMINAL QUICK COUPLING VALVE INLET SIZE.
2. TEFLON TAPE TO BE USED ON ALL THREADED JOINTS.

Figure 3 Quick Coupler Valve

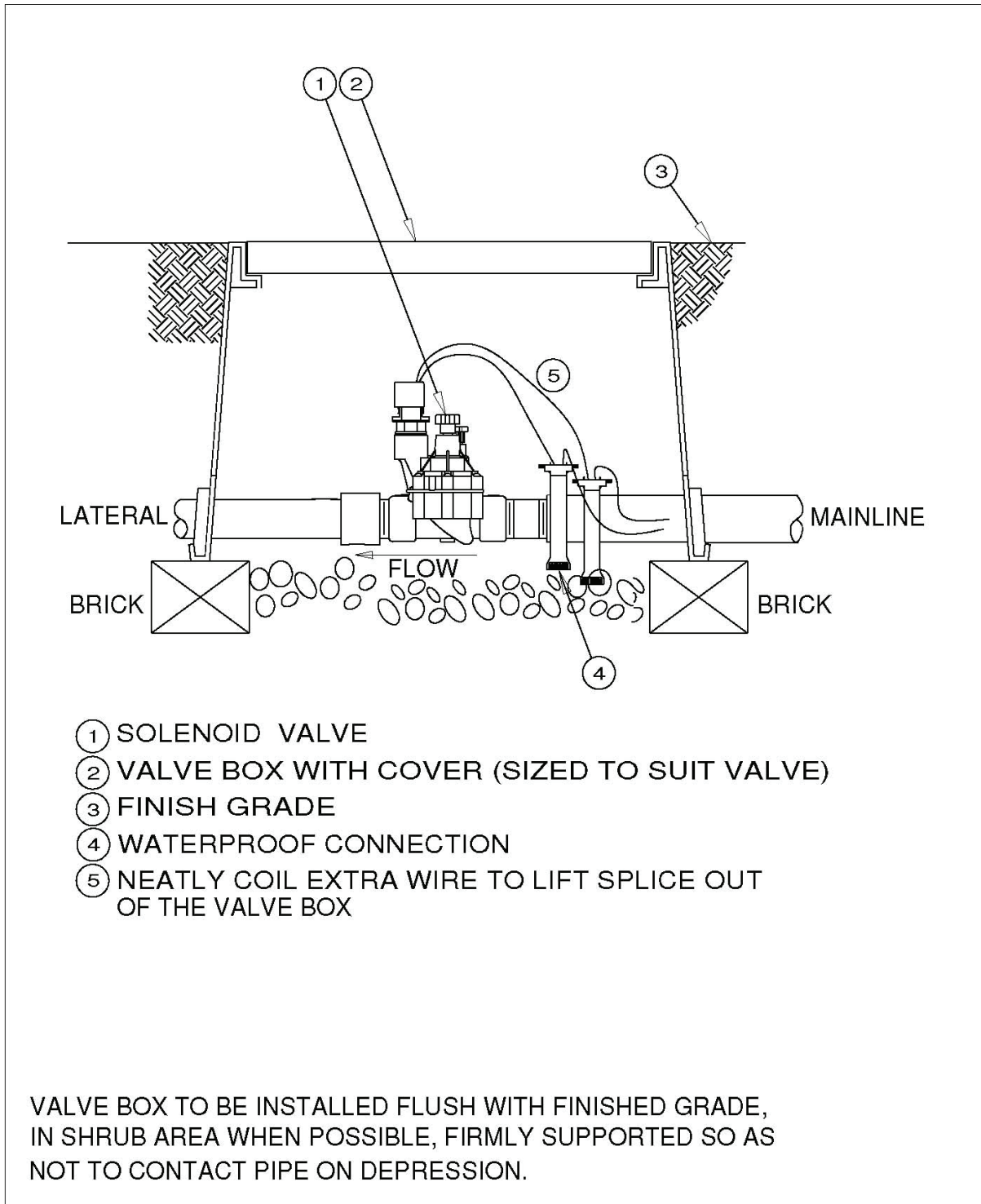

Figure 4 Electric Solenoid Valve

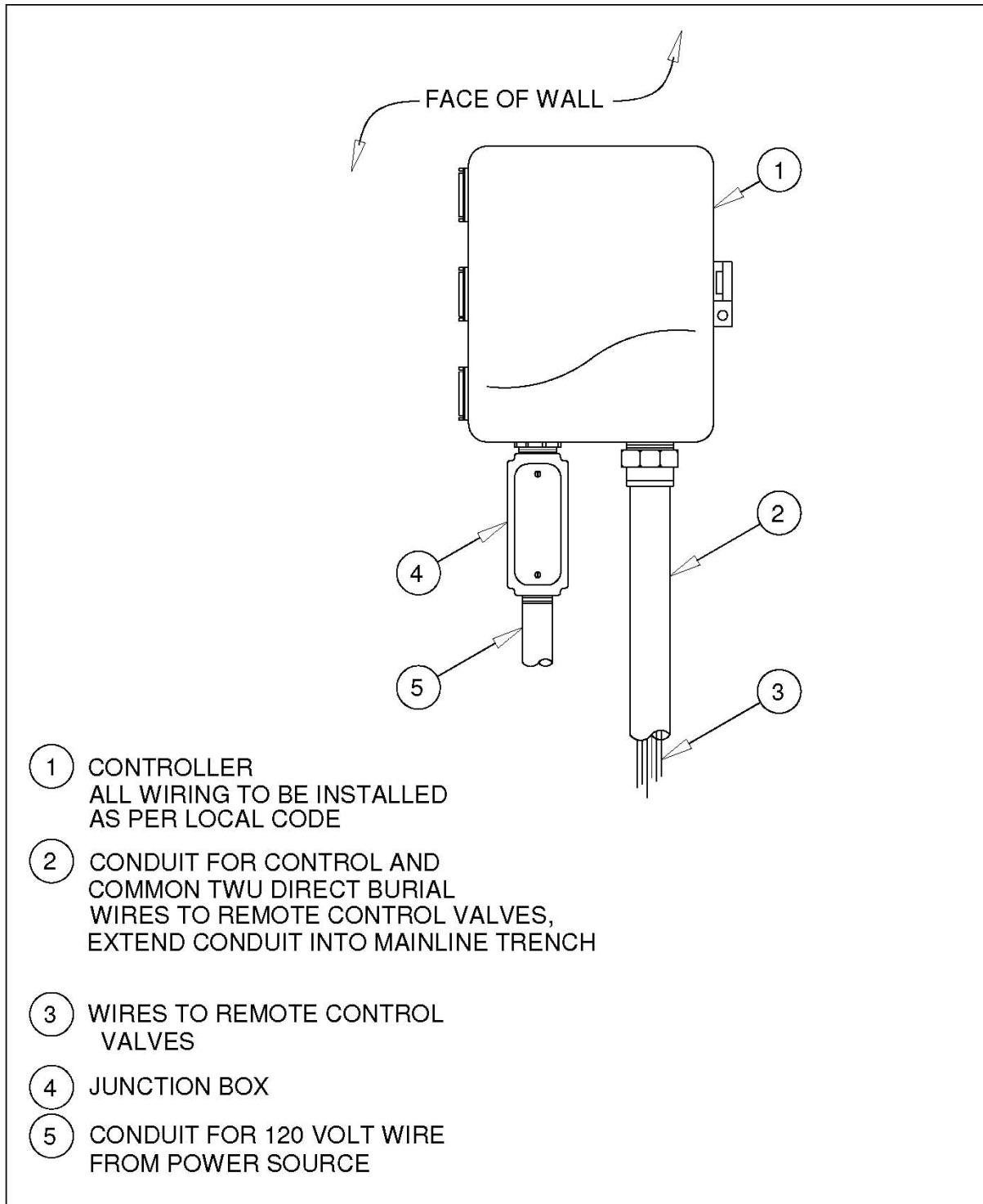

Figure 5 Controller -Wall Mount

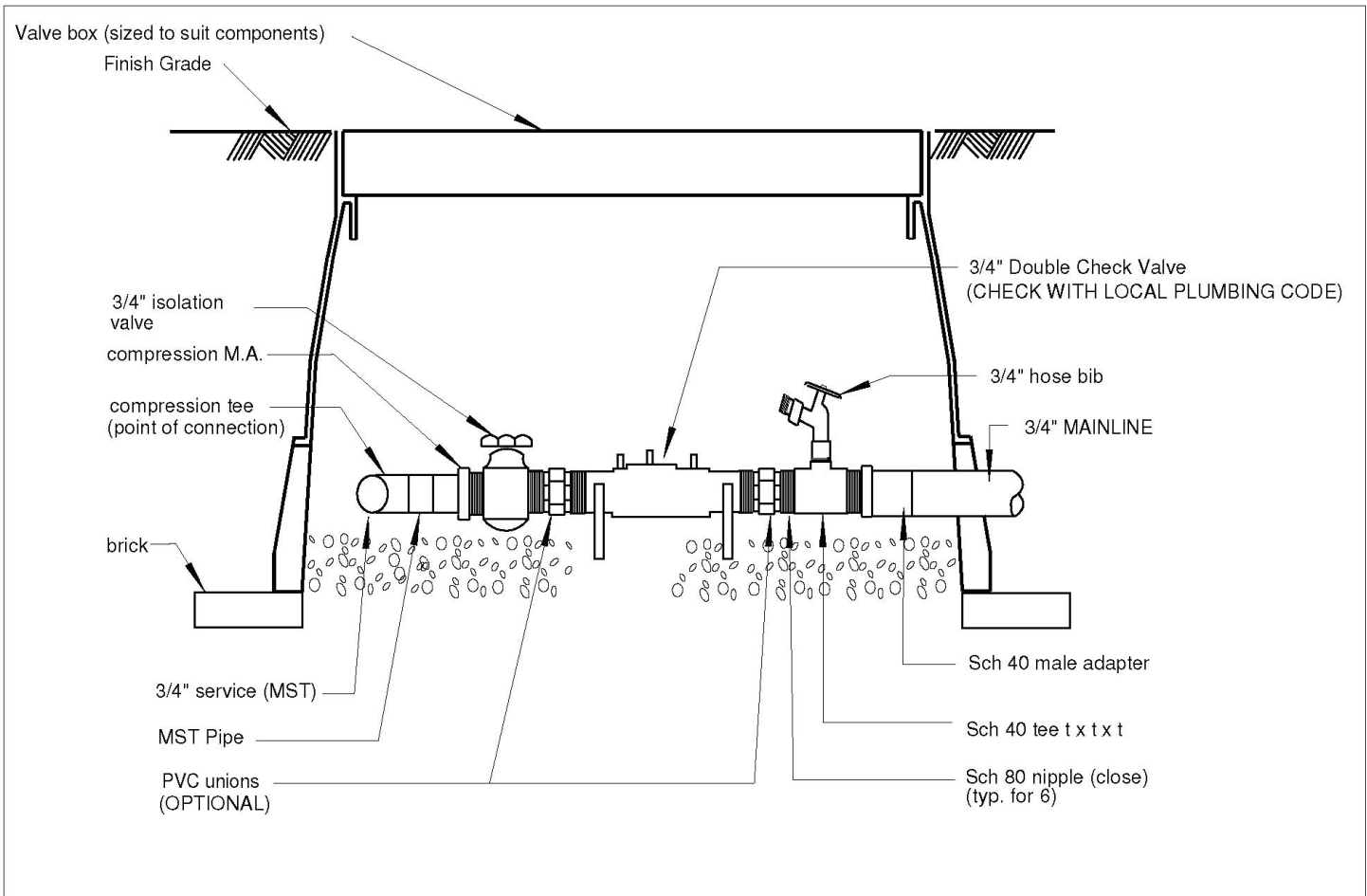

Figure 6 Residential Point of Connection



IRRIGATION PLANS / AS - BUILT PLANS Minimum Recommendation

Every owner of an irrigation system will need to locate the equipment buried on his/her property at some point in time. This is why an As-built Plan of the irrigation system is recommended.

It is a contractor's responsibility to supply an as built plan to the owner in the form of a reproducible *Scaled* plot plan. It is also recommended that the contractor retain a copy for his/her records.

As-built plans will indicate any changes from the original design of the proposed irrigation system.

Items included on a typical as-built plan are:

1. Scale of the drawing, complete with legend of equipment.
2. Date of the installation/ As-Built Plan
3. Minimum system requirements (e.g. 60 USGPM @ 55 PSI)
4. Location of the main connection referenced to a permanent structure. Information included shall be:
 - o The size and type of the pipe the system is connected to;
 - o Size and type of backflow prevention device;
 - o Location and type of winterization point.
5. Locations of all sprinklers used on the property, including the make and manufacturer of all sprinkler types used. The plan shall indicate what type is used in what location (usually done in the Legend)
6. Locations of all underground irrigation pipe including type and size of pipe (e.g. 1" PVC; 1/2" Poly, 3/4" PEX, 2" Copper, etc)
7. Location of all valves and valve Boxes, including make, model and size; as well as an indication of the operation (e.g. Manual operation or Automatic.)
8. Location of all irrigation controllers, including make and model.
9. Location of all buried wire and connection points.
10. Location and function of other irrigation equipment used on the project (e.g. Fertilizer injectors, Rain Shut-off Devices, Booster pumps, etc)
11. Location of all underground sleeves including the size and type of pipe.
12. Name and contact phone number and address of the installing contractor.



**IRRIGATION INDUSTRY ASSOCIATION
OF
BRITISH COLUMBIA**