

# Wastewater Treatment Plant Operator Certification Training



## Module 8: Overview of Advanced Wastewater Treatment Processes

Revised 2014

This course includes content developed by the Pennsylvania Department of Environmental Protection (Pa. DEP) in cooperation with the following contractors, subcontractors, or grantees:

The Pennsylvania State Association of Township Supervisors (PSATS)  
Gannett Fleming, Inc.  
Dering Consulting Group  
Penn State Harrisburg Environmental Training Center



## Topical Outline

### Unit 1 – Odor Control

- I. Sources and Types of Odors
  - A. Odor Generation
  - B. Impacts of Odors
  - C. Organic Vapors
  - D. Inorganic Vapors
  - E. Factors Affecting the Existence of Odors
  - F. Odor Detection
  - G. Managing Odor Complaints
- II. Solutions to Odor Problems
  - A. The Odor Detective
  - B. Chemical Treatment Alternatives for Wastewater Sources
  - C. Treating Air Containing Odors
  - D. An Ounce of Prevention – Good Housekeeping

### Unit 2 – Effluent Polishing

- I. Removing Solids from Secondary Effluents
  - A. Why is additional treatment necessary?
  - B. Alternatives for Effluent Polishing
- II. Chemical Precipitation
  - A. Chemicals Used to Improve Settling
  - B. Selecting the Right Chemical and Dosage
  - C. Physical-Chemical Treatment Process Equipment

- III. Gravity Filtration
  - A. Gravity Filtration Basics
  - B. The Filtration Process
  - C. The Backwash Process
  - D. Gravity Filtration Alternatives
  - E. Major Parts of a Gravity Filter
  - F. Operational Considerations
  
- IV. Pressure Filtration
  - A. Pressure Filtration Basics
  - B. Major Parts of a Pressure Filter
  - C. Operational Considerations
  
- V. Continuous Backwash, Upflow, Deep-Bed Granular Media Filtration
  - A. Benefits of Continuous Backwash, Upflow, Deep-Bed Granular Media Filters
  - B. Filter System Components
  - C. Operational Considerations
  
- VI. Cross Flow Membrane Filtration
  - A. The Basics of Membrane Filtration
  - B. Types of Membrane Filters
  - C. Membrane System Configurations
  - D. The Membrane Filtration Process
  - E. Operational Considerations

### Unit 3 – Phosphorous Removal

- I. Phosphorus Removal Basics
  - A. Why Remove Phosphorus
  - B. Technology Options for Phosphorus Removal
- II. Biological Phosphorus Removal
  - A. How the Process Works
  - B. Equipment Requirements
  - C. Operational Considerations
- III. Chemical Phosphorus Removal
  - A. Phosphorus Removal by Lime Precipitation
  - B. Phosphorus Removal by Alum Flocculation

### Unit 4 – Nitrogen Removal

- I. Nitrogen Removal Basics
  - A. Why Remove Nitrogen from Wastewater
  - B. Technology Options for Nitrogen Removal
- II. Biological Nitrogen Removal
  - A. Nitrification/Denitrification Process
  - B. Nitrification Reactors
  - C. Denitrification Reactors
  - D. Process Configurations Based on Sludge Management Options
  - E. Review of Biological Nitrogen Control Reactions
- III. Physical Nitrogen Removal By Ammonia Stripping
  - A. How Ammonia Stripping Works
- IV. Chemical Nitrogen Removal By Breakpoint Chlorination
  - A. How Breakpoint Chlorination Works
  - B. Equipment Considerations
  - C. Operational Considerations

## **MODULE 8: OVERVIEW OF ADVANCED WASTEWATER TREATMENT PROCESSES**

---

(This page was intentionally left blank.)

---

---

# Unit 1 – Odor Control

---

---

## Learning Objectives

- Identify the source and general types of wastewater odors.
- List three potential impacts of odors.
- List three factors affecting the existence of odors.
- Name a commonly used method to reduce odors from wastewater.
- Describe three methods for solving odor problems in air.

### Odor Generation

Odor generation is a common problem at wastewater treatment plants and in collection systems. In addition to the problems odors can create for plant personnel and plant equipment, odors can adversely impact the community surrounding the treatment plant. Not only is this a problem for the community, but it also puts a strain on treatment plant resources to solve the problem and appease the community. However, it must not be forgotten that controlling odors is an important community-relations task that must be addressed by treatment plant personnel.

### Biological Degradation of Wastes

- Gas production by microorganisms in the collection system and in treatment processes is the principal source of odors.
- Longer collection systems are more likely to become septic, which contributes to the production of odiferous gases and corrosion problems.



**Septic** is a condition produced by anaerobic bacteria. The wastewater produces hydrogen sulfide, turns black, gives off foul odors, contains little or no dissolved oxygen and the wastewater has a high oxygen demand. <sup>1</sup>

- The gases produced are classified as either organic or inorganic in nature. These gas types will be discussed later.

### Discharge of Odiferous Materials

- Odor may also be produced when odor-containing or odor-generating materials are discharged into the collection system.
- Industrial and commercial wastewater discharges are most likely to contribute these sources or odors.



### Impacts of Odors

Treatment plant personnel need to be aware that odors are not just a nuisance for the plant and potentially the community, but they can have significant impacts on plant personnel and treatment system equipment as well.

#### Safety Hazards

Several odiferous gases can overwhelm the sense of smell so that upon continued exposure, the odor can no longer be detected. This can create a dangerous situation because exposure to elevated concentrations of some gases can be fatal.

- A concentration of 300 parts per million (ppm) of hydrogen sulfide is immediately dangerous to life and health. While this is a strong concentration, hydrogen sulfide in small concentrations will destroy the mucous membranes in the nose and throat and numb the sense of smell. Continued exposure can cause drowsiness, coma, and eventually death if the victim cannot escape the exposure.
- The density of hydrogen sulfide is 0.0895 lbs/ft<sup>3</sup> at 20°C and 1 atmosphere (atm). This is 16% greater than air which has a density of 0.0752 lbs/ft<sup>3</sup> at the same temperature and pressure. Hydrogen sulfide can accumulate in confined spaces and in low lying areas and is highly flammable.
- Other gases, such as methane, which is actually odorless, can create an explosive atmosphere. The density of methane is 0.0417 lbs/ft<sup>3</sup> at 20°C and 1 atmosphere (atm). This most commonly becomes a problem in confined spaces, but it can happen elsewhere.
- The generation of any gases, odiferous or not, can create a life-threatening environment if the oxygen concentration in the atmosphere is reduced below approximately 19% (a suffocation hazard) or above approximately 23% (a potentially explosive atmosphere hazard).

#### Aesthetic Problems

Many disagreeable odors have a very low odor threshold.

- For example, hydrogen sulfide, the rotten egg odor, has an odor threshold of only 0.00047 ppm. Many other sulfur-based gases have similarly low odor thresholds.
- Gases also come in a wide variety of unpleasant odors. Since people have different abilities to detect odors and different tolerances to odors, aesthetic problems may be more subjective than objective.

### Maintenance Issues

Some gases can cause a corrosive atmosphere so that continued exposure of plant equipment and appurtenances to the gas will eventually cause severe damage.

- For example, when hydrogen sulfide vapor combines with water vapor, sulfuric acid will be formed. This will corrode sewers, wetwells, and other treatment plant facilities.
- Additionally, accumulation in the upper regions of the collection system will corrode the pipes and cause sewer lines and manholes to collapse.

### Organic Vapors



**Organic vapors** are defined as those that contain at least one C-H or C-C bond. Methane, CH<sub>4</sub>, is one of the simplest organic gases and is a common wastewater treatment plant gas.

#### Anaerobic Decomposition of Nitrogen & Sulfur Bearing Organic Compounds

Anaerobic decomposition of nitrogen and sulfur bearing organic compounds by microorganisms in the collection and treatment systems is the most common cause of organic vapors. The microorganisms use the oxygen bound to the source molecule for energy and replace the oxygen with hydrogen.

#### Examples of Organic Vapors

Common wastewater organic vapors include:

- Skatole (C<sub>9</sub>H<sub>9</sub>N) – has a fecal odor
- Indole (C<sub>8</sub>H<sub>7</sub>N) – has an ammonia-like odor
- Mercaptans (many varieties of thiols) – have a skunk-like or onion-like odor



**Thiols** are compounds similar to alcohols or phenols; however, a sulfur molecule replaces the oxygen

- The decomposition of carbohydrates and proteins is a common pathway for generation of organic vapors.

### Inorganic Vapors



**Inorganic vapors** include all vapors that are not organic vapors.

#### Examples of Inorganic Vapors

Hydrogen sulfide and ammonia are two very common odiferous wastewater vapors.

- Other examples of inorganic vapors range from carbon dioxide, nitrogen, oxygen (all of which have no odor), to chlorine, which has a sharp, pungent irritating odor and is also life-threatening at concentrations as low as 30 ppm.

### Factors Affecting the Existence of Odors

The presence and intensity of odors are affected by, and can be controlled by, environmental conditions such as temperature, pH, and dissolved oxygen concentration.

- Higher temperatures will cause the activity of microorganisms to increase, which generally will result in an increase in odor generation. Therefore, warmer climates are more likely to have odor issues. Higher-temperature industrial wastewaters can also cause odors to increase, which is one reason why sewer use ordinances limit the temperature of discharges.
- Chemical equilibria are affected by pH. Therefore, by proper control of pH conditions, the chemical equilibria can be managed so that odor causing compounds remain dissolved in the wastewater (in ionic form) rather than leaving the wastewater in gaseous form. For example, hydrogen sulfide will remain mostly in dissolved form when the wastewater pH is maintained above 7.5.
- When oxygen is dissolved in wastewater, microorganisms can fulfill their need for oxygen by using the dissolved oxygen rather than obtaining the oxygen bound in the compounds in the wastewater. Wherever reaeration occurs, such as in turbulent sewer flow or in a mixing tank, odor production will be less likely.

### Odor Detection

It is no longer necessary to rely on the human nose to detect and track odors. Modern technology has introduced an array of odor detection devices that can be more effective in measuring and tracking odors.

#### Olfactory Detection (Smell)

People have different sensitivities to odors, so relying strictly on the human nose to detect and track odors may not be very reliable.

#### *Odor Thresholds*

Odor thresholds are established by using groups of people collectively as a panel to evaluate diluted odors and determine the lowest concentration at which an odor can be detected. Odor thresholds for common wastewater substances are listed in the following table.

Table 1.1 Odor Characteristics <sup>2</sup>

**TABLE 1.1 ODOR CHARACTERISTICS<sup>a</sup>**

Substance	Remarks	Typical <sup>b</sup> Threshold Odor, ppm
Alkyl Mercaptan	Very disagreeable, garlic-like	0.00005
Ammonia	Sharp, pungent	0.037
Benzyl Mercaptan	Unpleasant	0.00019
Chlorine	Pungent, irritating	0.010
Chlorophenol	Medicinal	0.00018
Crotyl Mercaptan	Skunk	0.000029
Dimethyl Sulfide	Decayed vegetables	0.0001
Diphenyl Sulfide	Unpleasant	0.000048
Ethyl Mercaptan	Odor of decayed cabbage	0.00019
Ethyl Sulfide	Nauseating	0.00025
Hydrogen Sulfide	Rotten egg	0.00047
Methyl Mercaptan	Decayed cabbage	0.0011
Methyl Sulfide	Decayed vegetables	0.0011
Pyridine	Disagreeable, irritating	0.0037
Skatole	Fecal, nauseating	0.0012
Sulfur Dioxide	Pungent, irritating	0.009
Thiocresol	Rancid, skunk-like	0.0001
Thiophenol	Putrid, garlic-like	0.000062

<sup>a</sup> *MOP 11*, Chapter 27, "Odor Control," Water Pollution Control Federation, Washington, DC, 1976.

<sup>b</sup> Various references will list slightly different threshold odor concentrations.

### Gas Detecting Devices

Both hand-held devices and laboratory instruments are available for the detection and measurement of gas concentrations. These devices are calibrated with standard gas concentrations suitable for the service required. A variety of different gases can now be measured using hand-held devices.



What kind of gas-detecting devices are used in your treatment plant?

---



---



---



---



---

### Managing Odor Complaints

It is inevitable that wastewater treatment plants will create odors, and often the public will detect these odors. An important function of the wastewater treatment plant personnel is to respond to odor complaints promptly and courteously. It is important to show concern for the problem and a willingness to address the problem. If a spirit of cooperation can be fostered, the public may be more tolerant of occasional small odor problems than if an adversarial relationship exists.

## The Odor Detective

In order to monitor and control odors effectively, it is necessary to be able to distinguish between odors and to determine the probable cause or source of an odor, in part based on the type of odor detected. This ability to track down an odor comes with experience but also with knowledge about odor types and potential causes.

### Classification of Odors

Dealing with odors effectively starts with being able to describe the odor. While it is true that people react differently to odors and have different sensitivities, being able to classify an odor into a particular category may go a long way toward identifying the source of the odor. Operators should establish a classification system that works for them. Here is a common listing of offensive odor classifications.

Garlic,  
Medicinal,  
Skunk,  
Decayed cabbage,  
Ammonia,  
Fecal,  
Fishy,  
Rotten egg, and  
Decayed flesh.



Figure 1.1 Common list of offensive odor classifications <sup>3</sup>

### Source Detection

Once the odor has been classified, the detective work can begin.

- Skunk or onion-like odors are most often associated with sulfur compounds and are typically due to mercaptans (thiols).
- Fishy smells are produced by organic compounds containing nitrogen, often amines.
- Ammonia also is derived from organic compounds containing nitrogen, as are fecal odors. Rotten egg odor is caused by hydrogen sulfide.
- Being able to associate the chemical compounds associated with particular odors will help to determine a possible cause and potential solution to the odor problem.

### Systematic Approach to Odor Detection

Employing an orderly approach will work best when attempting to solve difficult odor problems.

- Evaluate housekeeping schedules and plant operations to help identify problem areas.
- A review of plant performance may reveal operations that may be deficient and potential sources of the odor problem.
- Following a systematic approach that eliminates sources one at a time is the preferred approach to odor problem solving.



What kinds of odor problems have you experienced at your treatment plant? How were they resolved?

---

---

---

---

---



## Chemical Treatment Alternatives for Wastewater Sources

As discussed previously in this unit, anaerobic conditions are a common cause of offensive odors. Therefore, preventing or eliminating the anaerobic condition will often provide the solution to the odor problem. Chemicals that produce an oxidizing environment are good choices to mitigate odors. Manipulating chemical equilibria can also be effective in eliminating odors.

### Chlorination

Chlorine is a commonly-used chemical at wastewater treatment plants for disinfection of plant effluent, so it is often available.



**Effluent** is wastewater or other liquid flowing out of a treatment plant or treatment process. <sup>4</sup>

- Because chlorine is a strong oxidizer, it is very good at eliminating many types of odors.
- Chlorine reacts readily with two common treatment plant odor-causing compounds: hydrogen sulfide and ammonia. In addition, chlorine is a disinfectant, so it will destroy odor-causing bacteria and inhibit slime growth in sewers and on treatment plant equipment.
- However, because chlorine is so reactive, much of the applied dosage will react with other compounds present that do not contribute to odor problems. Consequently, relatively high dosages of chlorine may be required to effectively deal with odor problems.

### Aeration

Aeration has proven very successful in the prevention of odor problems and in their cure.

- By preventing the development of anaerobic conditions, many microorganism-produced odors can be prevented.
- In an oxidizing environment, sulfate and nitrate will not be used as oxygen sources.
- Also, aeration provides a stripping effect that removes odiferous gases from solution. While this can, in some instances, cause odors to be released, a preventive program of aeration will generally not allow odors to develop.

### pH Control

pH control can be used in appropriate situations to prevent or mitigate odors by causing a shift in the chemical equilibrium to prevent the odiferous compound from forming.

- Generally, this occurs by maintaining a specified pH range to keep the component parts of the odiferous compound dissolved in solution. In this way, pH control can be effective in controlling hydrogen sulfide and ammonia odors, for example.

### Other Chemicals

Other oxidizing chemicals are also available to control odors, such as hydrogen peroxide, potassium permanganate, and ozone, among others. Also, chemicals such as chromate and zinc may be used to bind (by precipitation) the energy sources used by microorganisms and/or to create a toxic environment for the microorganisms, thus preventing the odor-causing compound from being generated.

## Treating Air Containing Odors

In some respects, treating air containing odors may be likened to closing the barn door after the horses have left. However, the managed collection and treatment of odors in air may be more economical than treating wastewater. Consequently, this approach to odor control is becoming more common. A variety of physical and chemical means are available to accomplish this.

### Chemical Absorbers



**Absorption** is the taking in or soaking up of one substance into the body of another by molecular or chemical action. <sup>5</sup>

- In the chemical absorption process, odiferous compounds become dissolved in an absorbing solution. To accomplish this, the air stream containing the odor must be brought into contact with the absorbing compound.
- The greater the opportunity for contact between the odiferous air and the absorber, the better the treatment. A common process for accomplishing this is called scrubbing, in which the air containing the odiferous compound is washed by a liquid stream that is the absorbing solution. The absorbing solution is selected and customized based on the nature and concentration of the particular odor-causing compound. The process could be as simple as a spray chamber or the more complex packed tower, in which the gas phase rises through a down-flowing liquid phase.

- Examples of chemical absorption systems are shown in Figure 1.2 (An electrolytic chemical scrubber using a brine solution) and Figure 1.3 (A chemical mist odor control system):

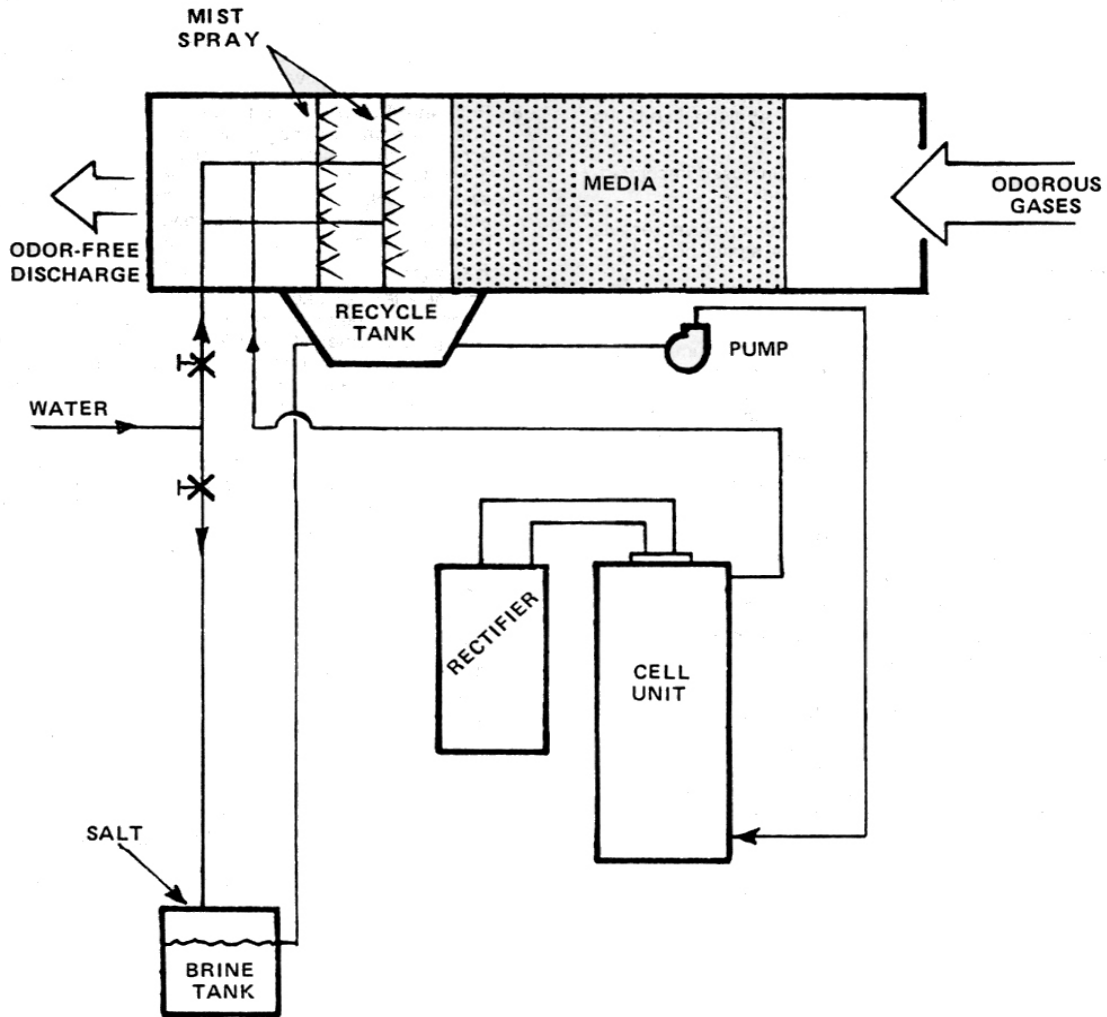

Figure 1.2 An electrolytic chemical scrubber using a brine solution <sup>6</sup>



Electrolytic solution is a solution that is capable of conducting electricity.

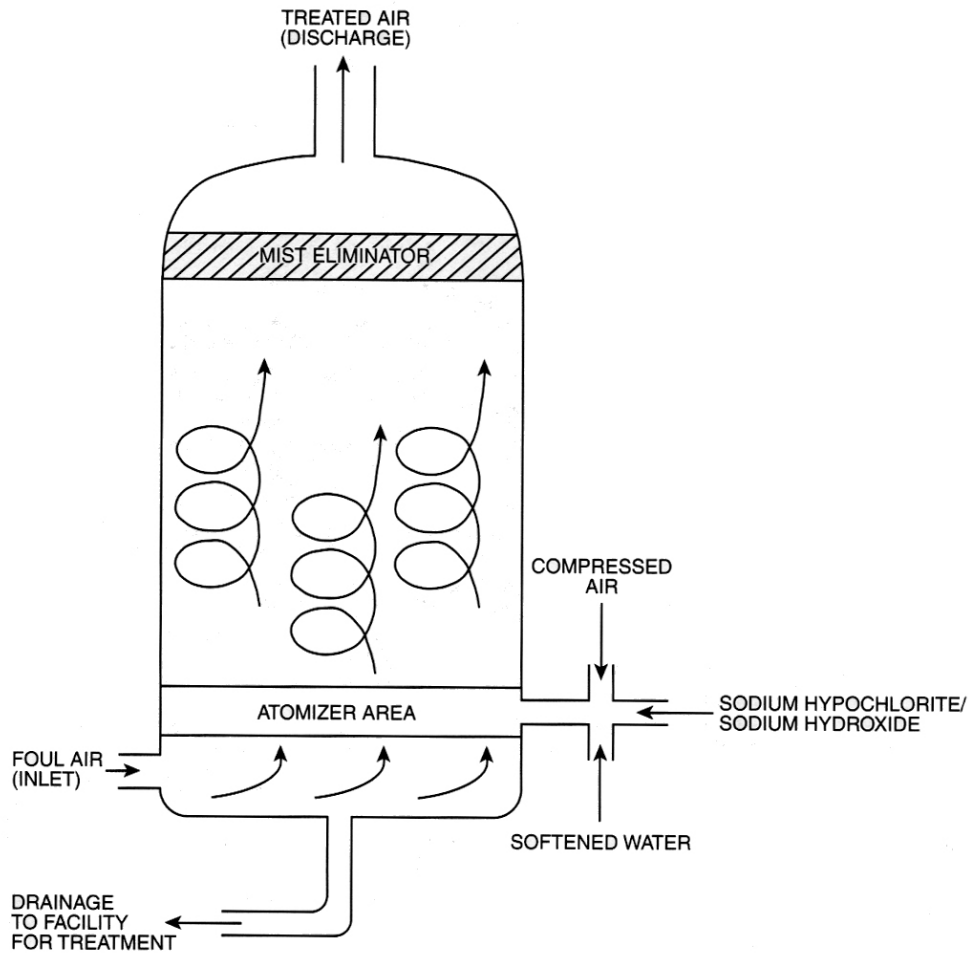

Figure 1.3 A chemical mist odor control system <sup>7</sup>

### Packed Tower Scrubbers

This treatment system generally consists of:

- A contact chamber with an inert packed bed media
- A scrubbing solution
- A recirculating system for the scrubbing solution
- An air blower to move the odiferous gas
- Associated ductwork and controls.

The configuration may use a countercurrent air flow (air rises through a falling liquid spray) as shown in Figure 1.4.

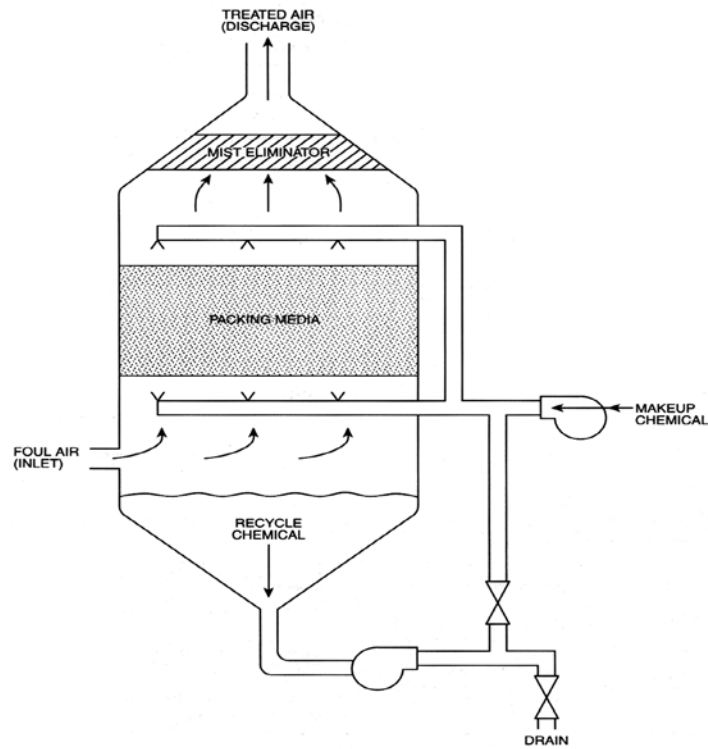

Figure 1.4 Packed tower scrubber with countercurrent air flow <sup>8</sup>

Or, it may use a cross air flow as shown below (air flow is at 90° angle to liquid flow direction).

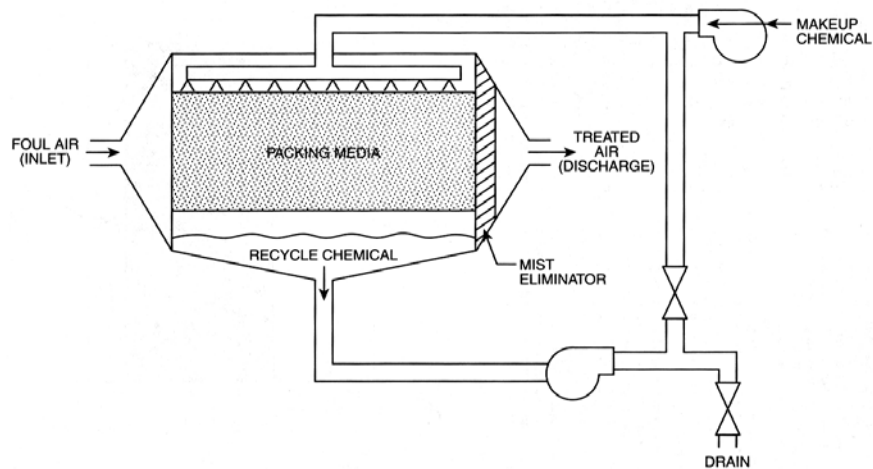

Figure 1.5 Packed tower scrubber with cross air flow <sup>9</sup>

In either case, the odor-carrying air passes through the packed bed where it intimately contacts the absorbing solution. The odor is removed from the air stream, which continues through the scrubber's mist eliminator and is discharged.

### Activated Carbon Adsorption

In the adsorption process:

- The odiferous compounds are contacted with and adhere to the surface of a solid phase.
- The most effective solid phases, such as activated carbon, have a very high surface area available to retain the odiferous compounds.
- The holding force may be either physical or chemical, depending in part on the odor-causing compound.
- Because activated carbon has a non-polar surface, it is effective in adsorbing a wide range of compounds, both organic and inorganic in nature.



Figure 1.6 A large-scale activated carbon system <sup>10</sup>

### Other Options

Some other odor control options for odors in air include:

- Biological odor removal towers
- Masking agents
- Combustion of the odiferous gases
- Ozonation



**Ozonation** is an oxidation process in which  $O_3$  is the active agent.

For additional information on these process options, refer to pages 32 and 33 of Advanced Waste Treatment, 3<sup>rd</sup> Edition.



Which of these methods for treating air containing odors are used at your treatment plant? How do they work?

---

---

---

---

---

### **An Ounce of Prevention – Good Housekeeping**

The best way to deal with odors is to prevent them from occurring, to the extent possible. This involves adherence to a comprehensive, well-designed maintenance schedule that reduces the probability that odors will develop into problems.

#### **Prevention as the First Line of Defense**

Maintenance ideas to prevent the likelihood of odors include:

- Minimizing detention times in pipes and wetwells.
- Maintaining dissolved oxygen in wastewater and recycle streams.
- Minimize solids deposition by maintaining sufficient velocities.
- Regular cleaning of structures prone to slime and growth accumulation.
- Regular cleaning of equipment and disposal of screenings and grit.
- Continuous or immediate removal of scum and floatables.

**Key Points for Unit 1 – Odor Control**

1. Odors coming from a wastewater plant can be both an important community-relations issue and a health risk to workers.
2. Some objectionable odors such as the rotten egg smell from hydrogen sulfide have a very low odor threshold in humans.
3. Some gases can cause a corrosive atmosphere that will eventually damage equipment.
4. Gases emitted by wastewater plants can be either organic or inorganic in nature.
5. The presence and intensity of odors can be affected by temperature, pH and dissolved oxygen concentration.
6. Both hand-held devices and laboratory instruments are available for the detection and measurement of gas concentrations.
7. Methods of treating odor problems in wastewater include chlorination, aeration, pH control and the addition of an appropriate chemical based on the cause of the odor.
  - Chemical treatment includes potassium permanganate, chlorine, or hydrogen peroxide.
8. Methods for treating air containing odors include adsorption, packed tower scrubbers, Ozonation and masking.



**Exercise for Unit 1 – Odor Control**

1. True or False: Some gases can cause a corrosive atmosphere that will eventually damage equipment.
2. The presence and intensity of odors can be affected by \_\_\_\_\_, \_\_\_\_\_, and \_\_\_\_\_.
3. Which of the following are effective in chemical treatment of odors
  - a. Silica
  - b. Potassium permanganate
  - c. Chlorine
  - d. Hydrogen peroxide
4. Which of the following are effective methods for treating air containing odors:
  - a. Adsorption
  - b. Potassium permanganate injection
  - c. Packed tower scrubbers
  - d. Ozonation

<sup>1</sup> Tom Ikesaki, "Chapter 1: Odor Control," in *Advance Waste Treatment*, (Sacramento, CA: California State University, Sacramento Foundation, 1998), p. 6.

<sup>2</sup> Ikesaki, p. 11.

<sup>3</sup> Ikesaki, p. 11.

<sup>4</sup> George Freeland, "Collection System Words," in *Operation and Maintenance of Wastewater Collection Systems*, Vol. I, (Sacramento California: California State University, Sacramento Foundation, 1999), p. 516.

<sup>5</sup> Ikesaki, p. 5.

<sup>6</sup> Ikesaki, p. 19.

<sup>7</sup> Ikesaki, p. 23.

<sup>8</sup> Ikesaki, p. 26.

<sup>9</sup> Ikesaki, p. 27.

<sup>10</sup> Ikesaki, p. 29.

(This page was intentionally left blank.)

---

---

# Unit 2 – Effluent Polishing

---

---

## Learning Objectives

- Identify two distinct technologies for polishing effluent wastewater.
- Describe the three main steps for chemical precipitation.
- Describe a typical jar test procedure.
- Identify the major components of a physical-chemical treatment system.
- For each of the following filtration systems, explain how they work, and identify the major system components and operational considerations:
  - Gravity Filtration
  - Pressure Filtration
  - Continuous Backwash, Upflow, Deep-Bed Granular Media Filtration
  - Cross Flow Membrane Filtration

### Why is Additional Treatment Necessary?

As more demands are placed on our water resources, the need to have cleaner water is becoming more important. Also, as more water users discharge their wastewater to the water resources, the quality of the effluent from each user needs to be cleaner to prevent any further reduction in the quality of the receiving water resources. Consequently, the discharge permits that specify the quality of the effluent discharged by the permit holder are now containing more stringent conditions.

These stricter discharge requirements often require the treatment plant to provide additional facilities beyond secondary treatment known as tertiary treatment. The use of tertiary treatment as a final treatment stage may be needed to meet the more stringent effluent limits. This advanced treatment can be accomplished by a variety of methods such as coagulation sedimentation, sand filtration, reverse osmosis, and extending secondary biological treatment to further stabilize oxygen-demanding substances or remove nutrients. In various combinations, these processes can achieve any degree of pollution control desired.

### Alternatives for Effluent Polishing

Effluent polishing, to remove additional contaminants from secondary wastewater discharges, provides a solution to meet the growing demand for cleaner wastewater discharges to water resources. Further solids removal is a primary goal of effluent polishing, although the overall effect of effluent polishing is to reduce particulates, BOD, and bacteria as well as solids. This can be accomplished using physical-chemical treatment as well as through several filtration process options.

#### Physical - Chemical Treatment

Physical-chemical treatment is a three-step process consisting of coagulation, flocculation, and liquids/solids separation.

- ✓ Step 1: Coagulation
  - Chemicals are rapidly mixed with the wastewater to induce ultra-fine particles with the same electrostatic charge to bind together.
  - The result is the formation of small agglomerations of similarly charged particles.
  - These particulates are called pinpoint floc and they are so small they do not readily separate from the wastewater
  
- ✓ Step 2: Flocculation
  - The wastewater is discharged to a separate tank where it is gently mixed, generally with polymer chemicals, to induce the smaller pinpoint floc to agglomerate into larger, denser particles that will more readily separate from the wastewater.
  
- ✓ Step 3: Separation

## **REMOVING SOLIDS FROM SECONDARY EFFLUENTS**

---

- This step allows the separation of the flocculated particles from the wastewater in a separate tank, generally a conventional gravity separator.

### Filtration



**Filtration** is a physical separation process to remove particulates from a liquid phase. The filtration process can consist of any of several different technologies to accomplish the separation, and will often be combined with the addition of chemicals to enhance the separation process.

Typical filtration technologies include:

- ✓ Gravity filtration
- ✓ Pressure filtration
- ✓ Continuous backwash, upflow filtration
- ✓ Membrane filtration

## Chemicals Used to Improve Settling

The purpose of using chemicals to treat secondary effluent is to create larger, denser particles that will readily separate from the secondary effluent. Without the use of these chemicals, the physical separation of wastewater particulates from secondary effluents would not be effective.

### Coagulation/Flocculation Basics



**Coagulant aids** are used to neutralize charges on molecules and particulates in the wastewater. Flocculants are used to agglomerate small particles into larger, denser particles that will more readily separate by gravity from wastewater.

- ✓ The first treatment step involves the addition of a chemical to aid in the coagulation process.
  - In addition to neutralizing charges on molecules and particulates, the coagulant aid may also alter the chemical equilibrium of the wastewater causing the precipitation of insoluble molecules and complexes.
  - The precipitation process causes otherwise dissolved atoms or molecules to be removed from solution.
  - The reactor in which the coagulation occurs provides only a short retention time, so over mixing and the breakup of coagulated particles, will not occur.
- ✓ Flocculation occurs in a separate reactor with a much less intense mixing regime.
  - Polymers are generally used to facilitate the flocculation process. The long-chain polymer molecules wrap around several coagulated particles creating larger and denser particles that will separate readily from the wastewater. This is illustrated in Figure 2.1.

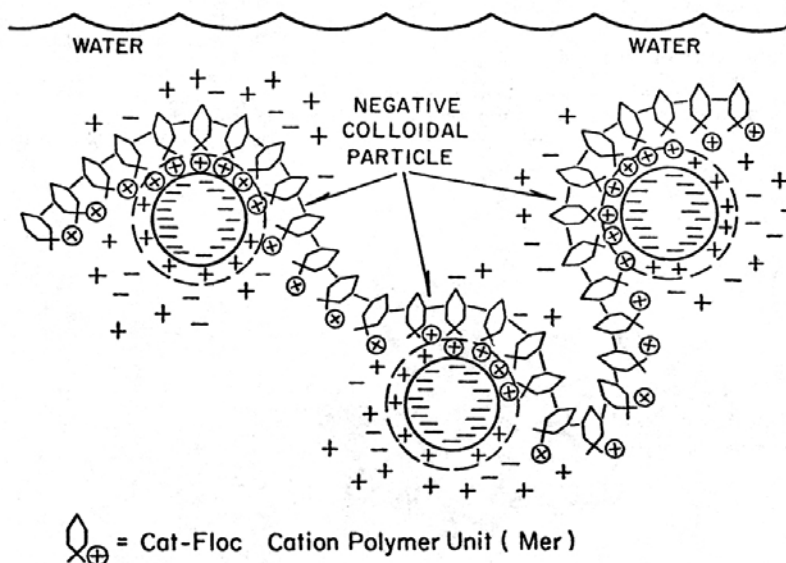

Figure 2.1 Illustration of the Coagulation-Flocculation Process <sup>1</sup>



## Chemical Coagulants

- ✓ Common coagulants include:
  - Alum (aluminum sulfate)
  - Ferric chloride
  - Lime
  - Certain polymers
- ✓ Alum and ferric chloride are effective in destabilizing charged particles while also producing hydroxide precipitates, which are insoluble in water. These hydroxide precipitates are gelatinous in nature so they do not readily release water, and therefore create a bulking, low-density sludge. Without the addition of flocculants, these chemicals would produce a large sludge volume that would make the overall process relatively ineffective.

## Chemical Flocculants

- ✓ Flocculation is generally accomplished with the addition of a polymer.
- ✓ Polymers with different ionic characteristics are available and comprise:
  - Anionic polymers (negatively charged)
  - Cationic polymers (positively charged)
  - Nonionic polymers (neutrally charged)
- ✓ Polymers with a wide range of molecular weights and charge densities are also available.
- ✓ The selection of the appropriate polymer for the process is an important part of the process design.
- ✓ A polymer map, shown in Figure 2.2, may be used to assist in initial selection of an appropriate polymer.

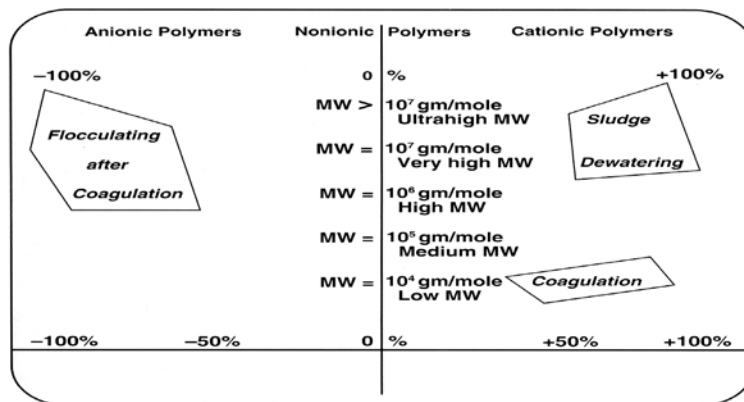

Definitions:  
 1. MW = Molecular Weight.  
 2. gm/mole = molecular weight of a substance expressed in grams.

Figure 2.2 A Polymer Map <sup>2</sup>

## Selecting the Right Chemical and Dosage

A polymer map can be a useful tool for the initial selection of a polymer. However, more rigorous testing of both coagulants and flocculants on the specific wastewater to be treated is the appropriate method to use when designing a chemical treatment process.

### Jar Testing



**A jar test** is a valuable tool for selecting chemicals and dosages for a chemical treatment process.

- ✓ Jar testing equipment consists of a gang of mixers (often six) used generally with beakers that serve as reactors (refer to Figure 2.3).

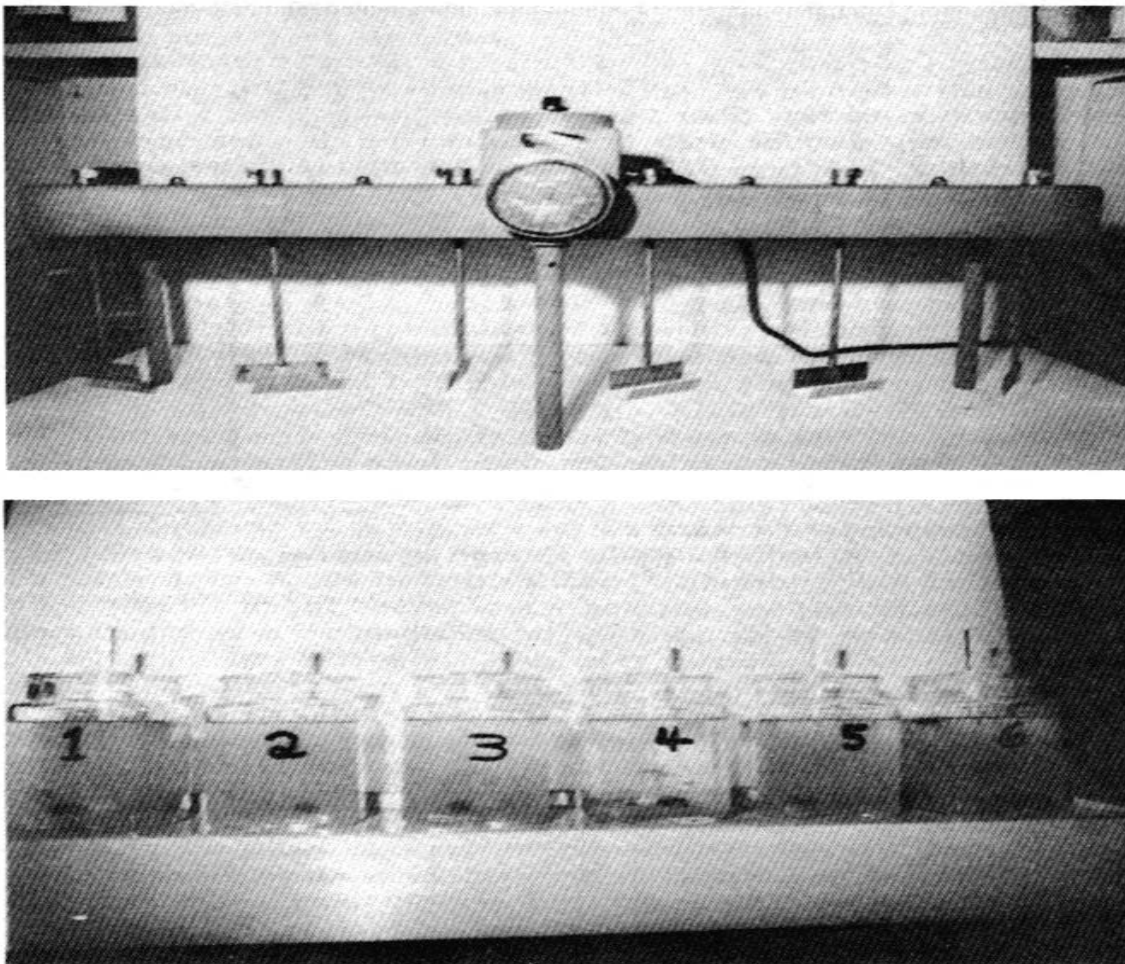

Figure 2.3 Jar Testing Equipment: Mechanical Stirrers and Magnetic Stirrers<sup>3</sup>

- ✓ Jar tests are used to conduct a simultaneous evaluation of several chemicals or several chemical dosages.
  - The test is conducted by rapidly mixing the beakers containing the wastewater and the various coagulants.
  - Just before reducing the mixing to a slow speed, flocculant is added.
  - After mixing at slow speed for the appropriate time, the mixers are shut off and the floc is allowed to settle.
  - A more rigorous protocol for conducting the jar testing is presented in the textbook.

### *Evaluating Results*

Initial evaluations can be made by visually observing the performance of each reactor as to the nature of the floc and the supernatant (liquid). More rigorous evaluation, after preliminary testing has been conducted, would involve recording the chemicals and dosages used in each reactor; recording the characteristics of the floc formed; the speed at which the floc settled; the volume of the sludge generated; and the characteristics of the supernatant (liquid).

### *Scaling the Test*

- ✓ Once a chemical has been selected as the most likely candidate for use, the testing should be conducted in the wastewater treatment facility itself.
- ✓ The amount of chemical to be added will be calculated based on the dosage requirement from the jar testing. A range of dosages bracketing the testing dosage should be used. Each dosage would be applied for a specified time.
- ✓ Untreated and treated wastewater will be analyzed several times during the course of each test to document the performance of each dosage.

### *Performance Optimization*

- ✓ Performance optimization involves the periodic testing of system performance once the selected chemicals and dosages are applied to the full-scale operation. Analysis of treated effluent is most important, while analysis of untreated wastewater may be less frequent, or possibly based on historic information if appropriate.

## Physical-Chemical Treatment Process Equipment

Slight variations in the physical-chemical treatment equipment may be required based on the nature of the chemicals used in the process.

### Chemical Storage and Mixing Equipment

Coagulants and flocculants may be available in either solid or liquid form. The specific equipment requirements for storage and mixing will depend on the form used.

#### ✓ Solid Chemicals

- Solids need to be dissolved in water before they can be used. Special equipment is required to properly meter the solid, wet the solid and mix it into a useable solution (see to Figure 2.4).

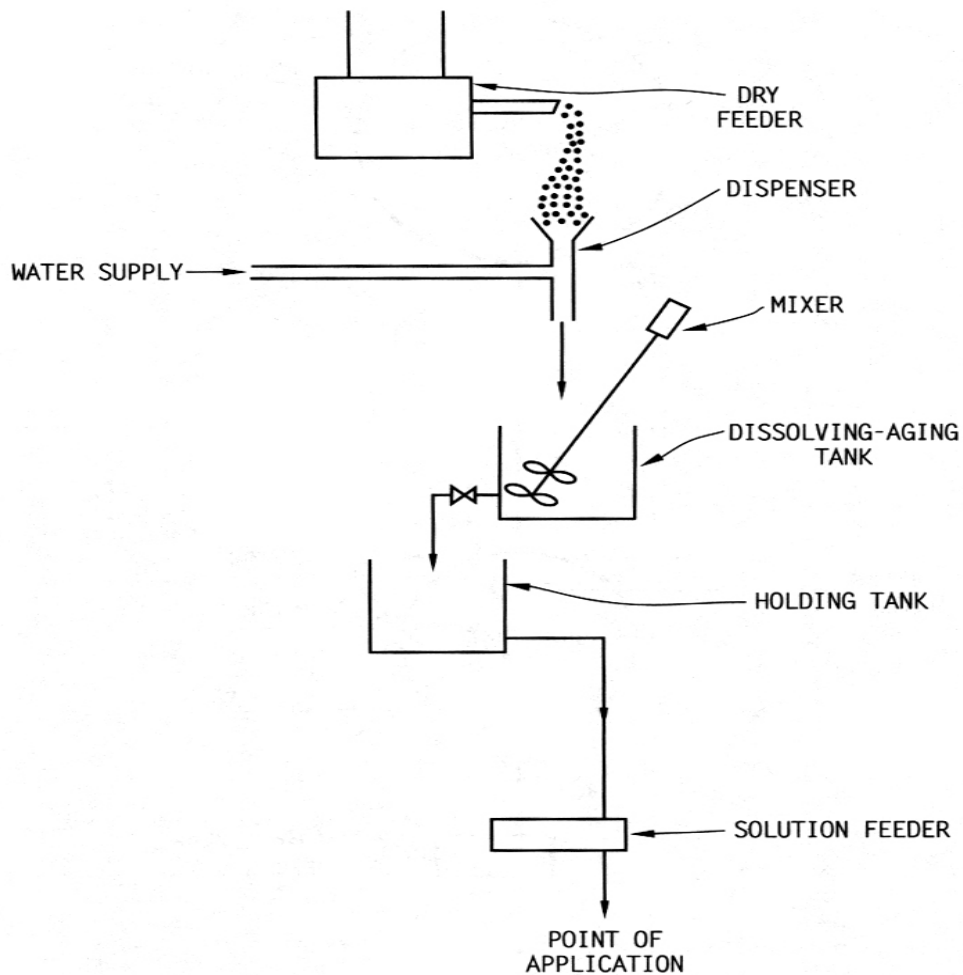

Figure 2.4 Dry Chemical Feed System <sup>4</sup>

- Polymers can be difficult to dissolve and require extra care when preparing solutions. Generally, polymers need to age before their full effectiveness is achieved.
  - Once the solution at the selected concentration has been prepared, it may be transferred to a day tank (holding tank) and diluted to the use concentration. From there, it is metered to the point of application.
  - Storage of the solid itself requires an appropriate bin or dry tank with the necessary environmental controls.

### ✓ Liquid Chemicals

- Liquid chemicals are often received in a concentrated form then diluted for use. Consequently, a day tank may be used to mix the liquid chemical to the appropriate concentration and hold it for metering to the point of application.
- Polymers generally require dilution and aging before use to bring them to their full effectiveness.

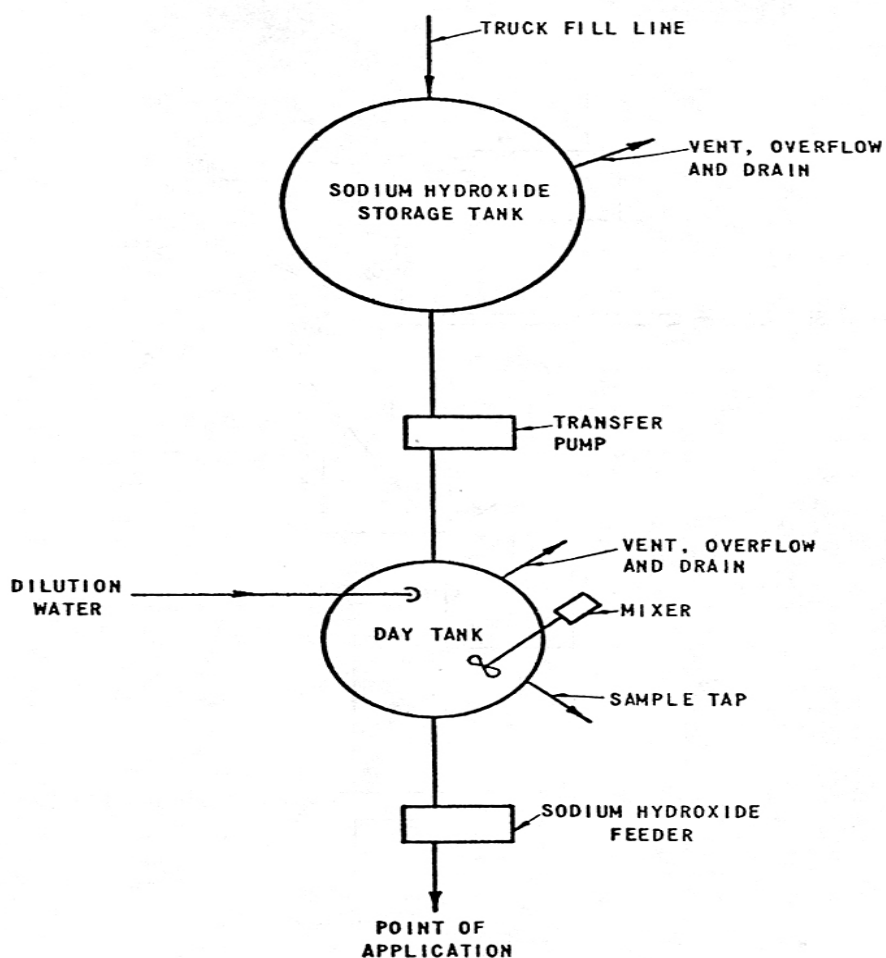
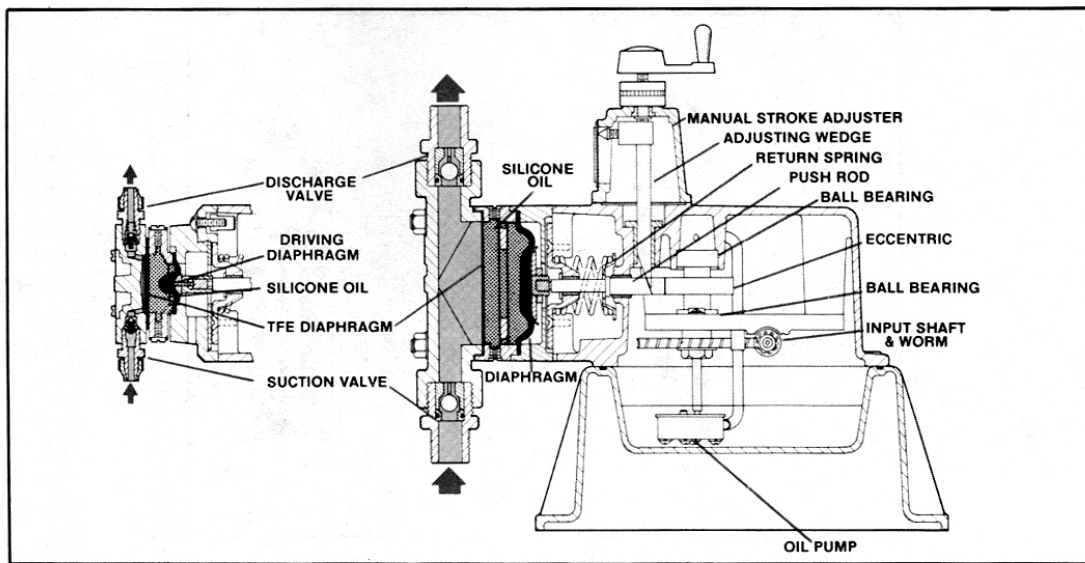

Figure 2.5 Liquid Chemical Feed System With Day Tank <sup>5</sup>

**Chemical Feed Equipment**

- ✓ Chemical feed pumps are generally used to meter chemical solutions at an accurate rate to the point of application.
  - The pumps can be provided with rate controllers that will allow the chemical to be metered at a rate that matches the demand for the chemical.
  - The demand can be determined by wastewater flow rate or some measurable characteristic of the treated wastewater.
  
- ✓ Positive displacement pumps using a plunger or a diaphragm are typically used for liquid chemical feed.
  - The length of the stroke and the stroke frequency can be adjusted manually or automatically to vary the chemical feed rate.



**Diaphragm Pump**

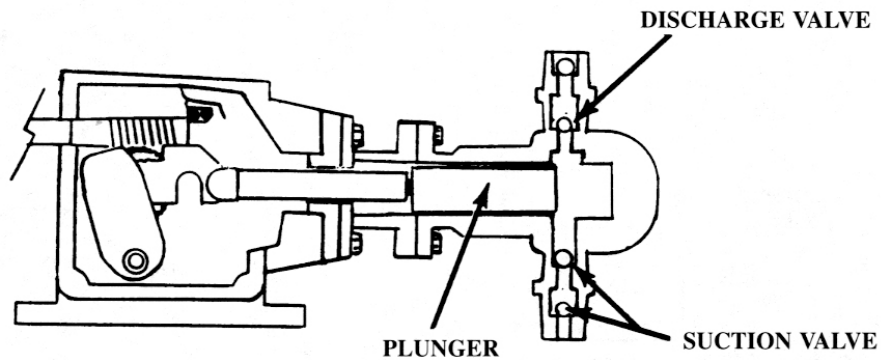

**PLUNGER PUMP**

(Courtesy of Wallace & Tiernan)

Figure 2.6 Positive Displacement Pumps: Diaphragm Pump (top) and Plunger Pump (bottom) <sup>6</sup>

- ✓ Screw feeders are commonly used to meter solid chemicals to solution tanks or the point of application.
  - The feed rate is adjusted by varying the screw rotation rate.
  - Other chemical feeder designs are also used.

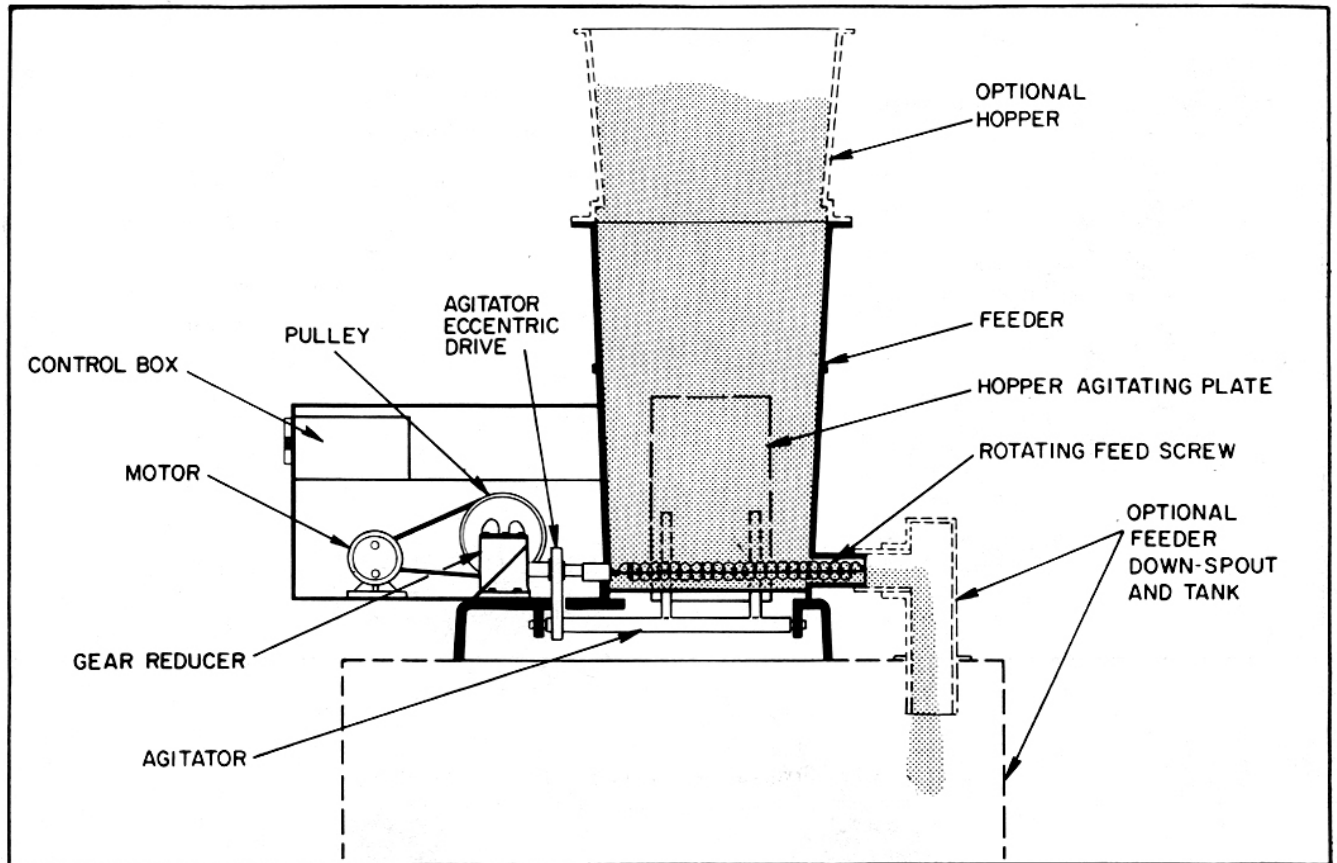

Figure 2.7 Screw Feeder For Dry Chemical 7

### Coagulant Mixing Units

- ✓ Coagulant mixing tanks have a short detention time and a high rate mixing regime to introduce the chemical, create a homogeneous solution, and create intimate contact between the fine particulates to cause coagulation.
- ✓ The mixing is most often achieved with high-speed impeller or turbine mixers. However, in-line static mixers, which use baffles and a high velocity throughput to create the turbulence necessary for high rate mixing, are also used.

**Flocculators**

- ✓ Flocculators use relatively large paddles or impellers running at a relatively slow speed to produce the optimum mixing regime to enhance agglomeration of the coagulated particles.
- ✓ Generally, the flocculating time will be five to 10 times longer than the coagulating time.

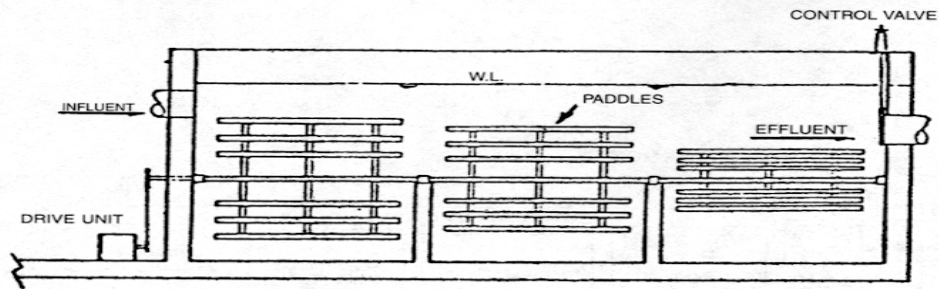

**Mechanical Flocculation Basin  
Horizontal Shaft — Reel Type**

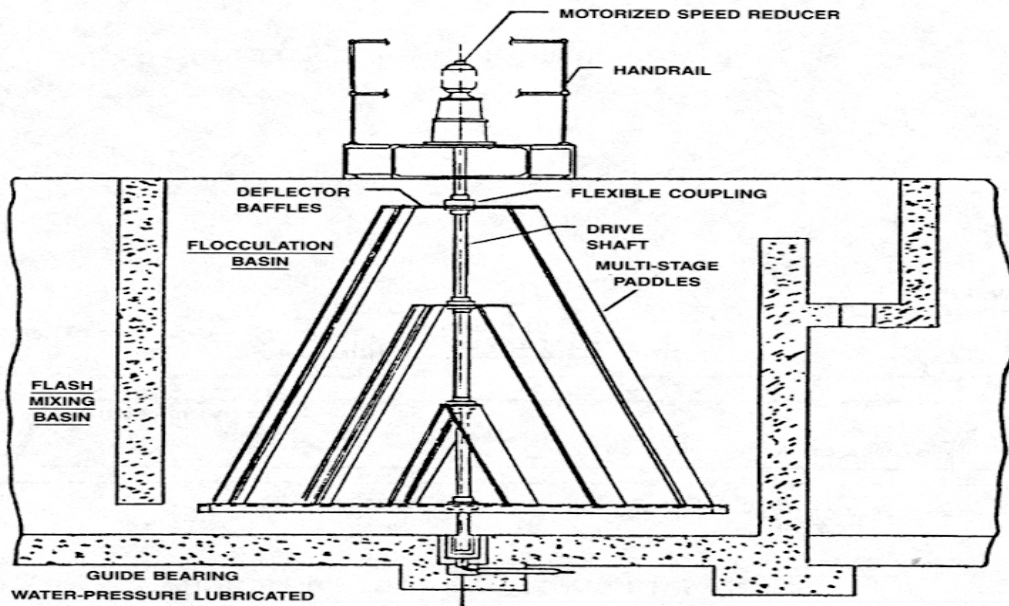

**Mechanical Flocculator  
Vertical Shaft — Paddle Type**  
(Courtesy of Ecodyne Corp.)

Figure 2.8 Mechanical Flocculators<sup>8</sup>



**Clarifiers**

- ✓ Conventional sedimentation clarifiers are generally used for solids separation.
- ✓ Clarifier design may be rectangular or circular.
  - Rectangular – uses a chain and flight or a traveling bridge for solids collection

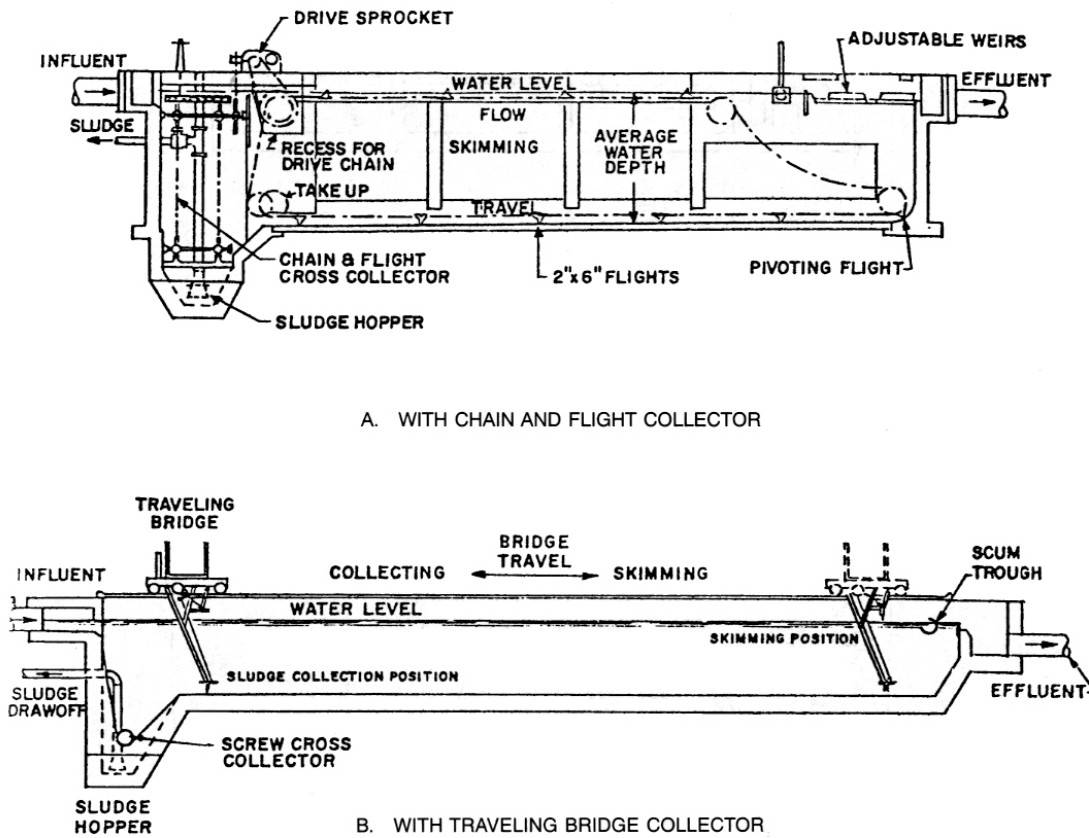

Figure 2.9 Rectangular Sedimentation Clarifiers: Chain and Flight (top) and Traveling Bridge (bottom) <sup>9</sup>

- Circular – solids are scraped to the center of the tank into a collection well
- Variations on these designs are used, with various degrees of sophistication.

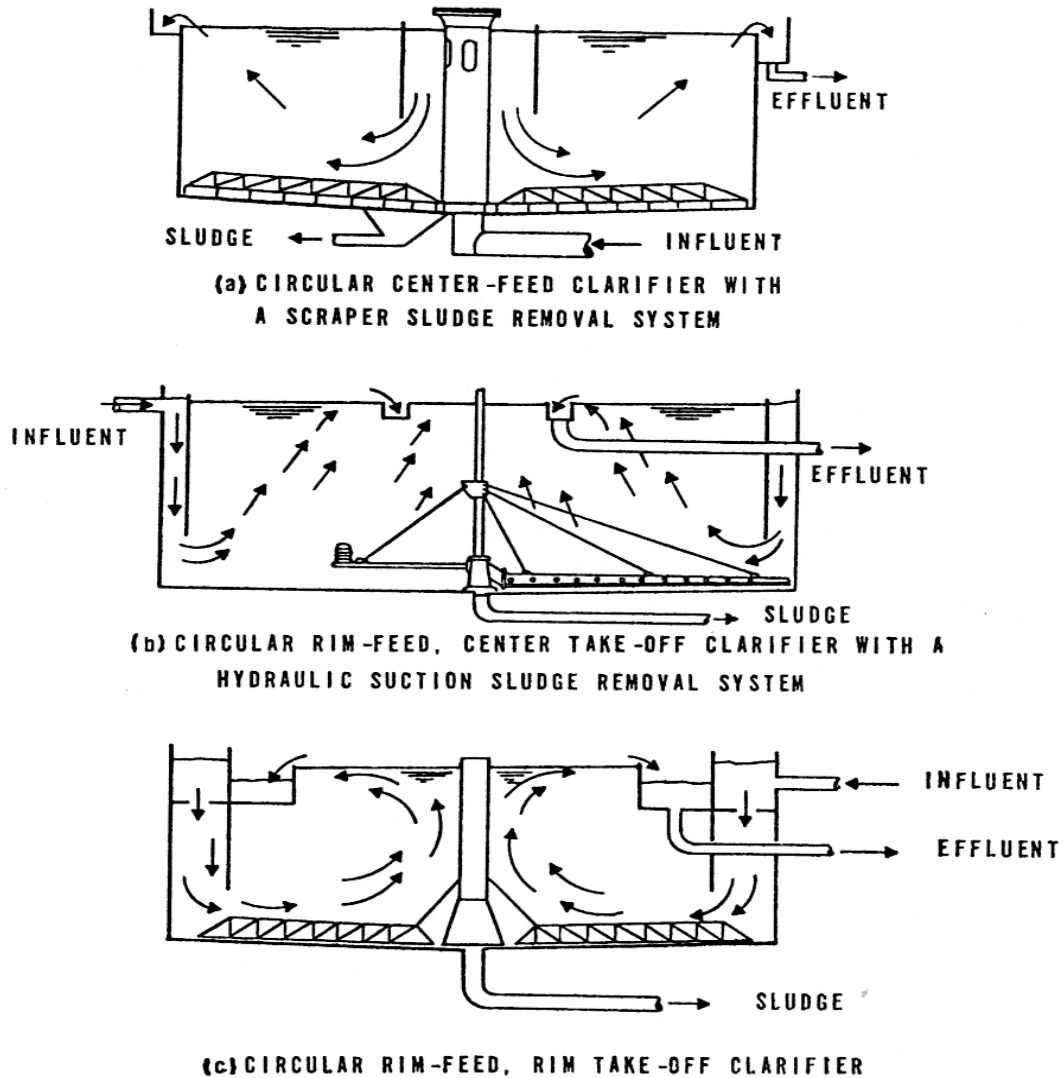

Figure 2.10 Typical Circular Clarifiers<sup>10</sup>

- ✓ Tube settlers are also used which reduce the distance solids are required to travel before they are removed from the solution.

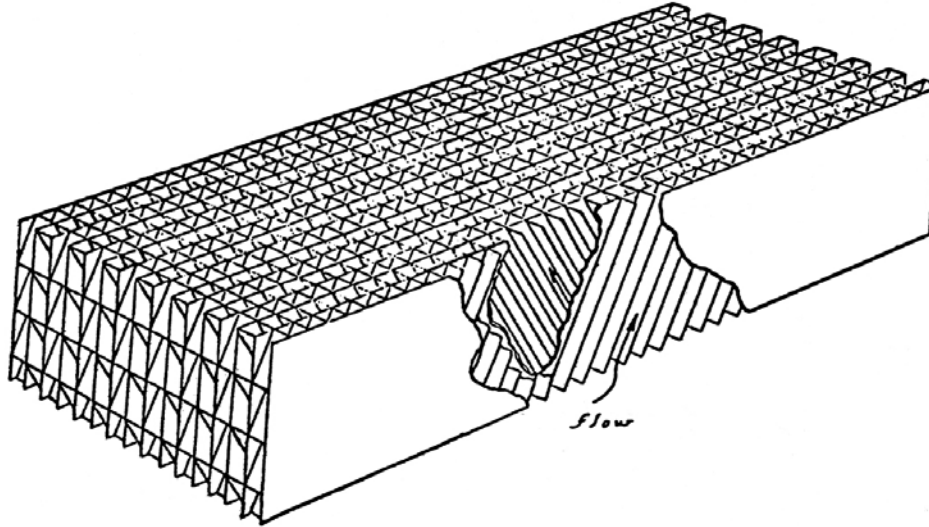

Figure 2.11 Tube Settler Module <sup>11</sup>

### Sludge Management

- ✓ The sludge level in the clarifier should be maintained at the lower end of the operating range.
- ✓ Set controls to remove sludge from the clarifier regularly; do not use the clarifier for sludge holding.
- ✓ Typically, a sludge thickening tank will be used to hold and thicken the sludge, with decanted water returned to the head of the treatment plant for processing.

### Operation and Maintenance Considerations

Good operational practices include:

- ✓ Monitor and calibrate chemical feeders regularly.
- ✓ If automatic feed control is not used, manually adjust chemical dosing to match flow rates.
- ✓ Visually observe the coagulation and flocculation performance for upsets or needed adjustments.
- ✓ Monitor the effluent characteristics to check system performance and identify needed adjustments.
- ✓ Evaluate system performance in consideration of overall treatment plant performance.

Maintenance considerations include:

- ✓ Maintain the spare parts necessary to keep the system running.
- ✓ Check dry feeders often for plugs and voids and polymer mixing tanks, especially for fisheyes (incompletely mixed chemical).
- ✓ Routinely check level alarms for chemical holding tanks.
- ✓ Check chemical feed pumps for proper operating pressure, especially diaphragm pumps.



**Exercise**

1. What is the importance of mixing in the coagulation process?

---

---

---

---

2. What is flocculation?

---

---

---

---

3. Briefly describe the jar test procedure.

---

---

---

---

## Gravity Filtration Basics

In wastewater treatment operations, gravity filtration involves the removal of suspended solids from wastewater through the application of the wastewater to a medium that allows the water to pass through while retaining the solids. No forces, other than gravity, are at work to affect the separation.

The most common applications of gravity filtration at wastewater treatment plants include:

- ✓ Separation of residual biological floc from secondary treatment systems, such as trickling filters and activated sludge.
- ✓ Removal of floc following chemical treatment of secondary effluent.

## The Filtration Process

Most filtration systems operate on a batch basis. This means that wastewater is applied to the filter until its solids handling capacity is reached. At that point, the head loss through the filter, caused by the accumulated solids, becomes excessive and the filter must be cleaned. Water is applied to the filter in the opposite direction, called backwash, to flush the solids from the filter so a new cycle can be initiated.

### Influent Distribution to the Top of the Media

- ✓ The influent distribution system typically includes an inlet valve and distribution piping that allows the influent to be evenly distributed over the surface of the filter for more effective treatment.

### Solids Capture on the Media

- ✓ The nature of the filter medium is designed so that water will pass through but solids will be retained.
- ✓ The type and configuration of the filter medium can be selected based on the nature of the solids to be separated and the quality of effluent required.

### Collection of Effluent in Underdrain System

- ✓ The underdrain system is generally a piping configuration at the bottom of the filtration system that allows the uniform removal of treated effluent from the filtration system.
- ✓ The underdrain must also be designed to evenly apply backwash water across the bottom of the filter surface when the filter is being cleaned (backwashed).

**Effluent Flow Rate Monitoring and Control**

- ✓ After entering the underdrain, the treated effluent might pass through a flow meter that controls a rate valve. This arrangement controls the flow through the filter within the desired range. This helps control the head loss through the filter and the quality of the effluent.

**The Backwash Process**

The backwash process removes accumulated solids from the filter. Generally this will be accomplished by stopping the influent flow, changing valve positions, and pumping treated effluent in a reverse direction (upward) through the filter.

**Monitoring Head Loss to Avoid Breakthrough**

- ✓ Manufacturers' recommendations or operating experience will dictate when head loss through a filter has reached the point that backwashing is required. The head loss is measured as the difference in pressure between the influent and effluent sides of the filter (see Figure 2.12).

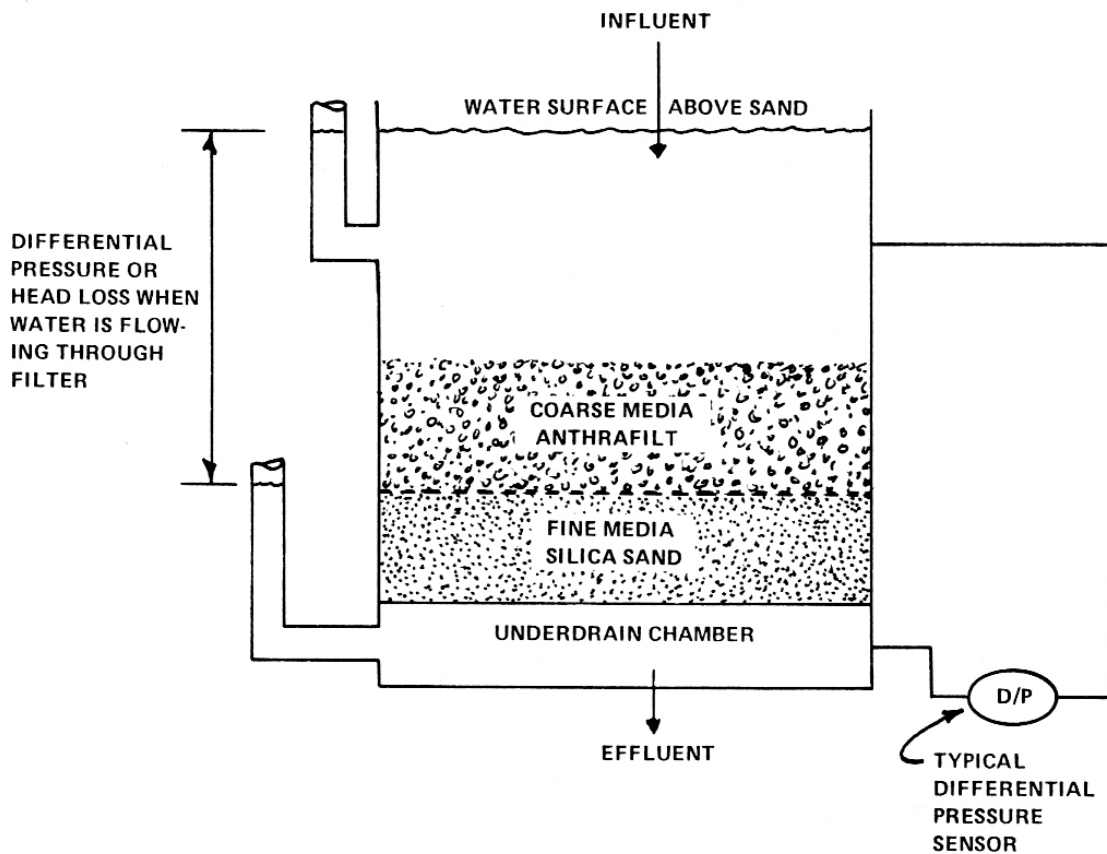

Figure 2.12 Differential Pressure Through a Sand Filter <sup>12</sup>

### Backwash Water Applied Through Underdrain System

- ✓ Backwash water enters the filter system through the underdrain system so that the backwash water is applied evenly across the bottom face of the filter medium. This helps ensure a uniform cleaning of the filter medium.

### Upward (Reverse) Flow of Backwash Water Fluidizes the Media

- ✓ As the backwash water flows upward through the filter medium, if the medium is not fixed, it will fluidize at the proper backwash rate. This means that the medium will unpack and become suspended in the backwash water. This suggests that the backwash flow rate must be controlled to cause the medium to float but avoid flushing the filter medium out of the filtration system.

### Solids are Carried Out with Wash Water to Discharge

- ✓ The force of the upward backwash flow and the turbulence created by the fluidization of the filter medium removes the solids from the filter medium and carries the solids to the top of the filtration system where the backwash water and the solids are removed from the system via collection troughs.

### Alternative Processes

- ✓ Alternative backwashing schemes are available with different equipment:
  - Externally Cleaned Media
    - In some instances, the filter medium may be removed from the system and cleaned externally in a separate cleaning system. Then the cleaned medium will be returned to the filtration system.
  - In-Process Cleaning of Media
    - In other systems, cleaning of a portion of the filter medium may occur while the remainder of the filtration system continues to operate. In this case, an air scour or traveling backwash system is activated for the portion of the filter medium to be cleaned.



## Gravity Filtration Alternatives

Different filter medium types are available as well as different filtration configurations. The discussion of all the possible arrangements is beyond the scope of this lesson; however, these alternatives fall into two general categories of filtration – surface straining type and depth filtration type. The following is a discussion of these two filter types with examples of each type.

### Surface Straining Type

- ✓ A surface straining filter medium is designed to remove solids at the top face of a downflow filter.
- ✓ With this design, the filter medium provides the initial filtration, however, as solids accumulate on the filter surface, they also provide a filtering medium that is often more effective than the filter medium alone.
- ✓ In this configuration (as opposed to depth filtration), head loss builds more rapidly, and backwashing is more frequent; however, solids breakthrough (to the effluent) is not a concern.

### Rapid Sand Filters

Rapid sand filters are often used in wastewater treatment plants. They are surface straining filters.

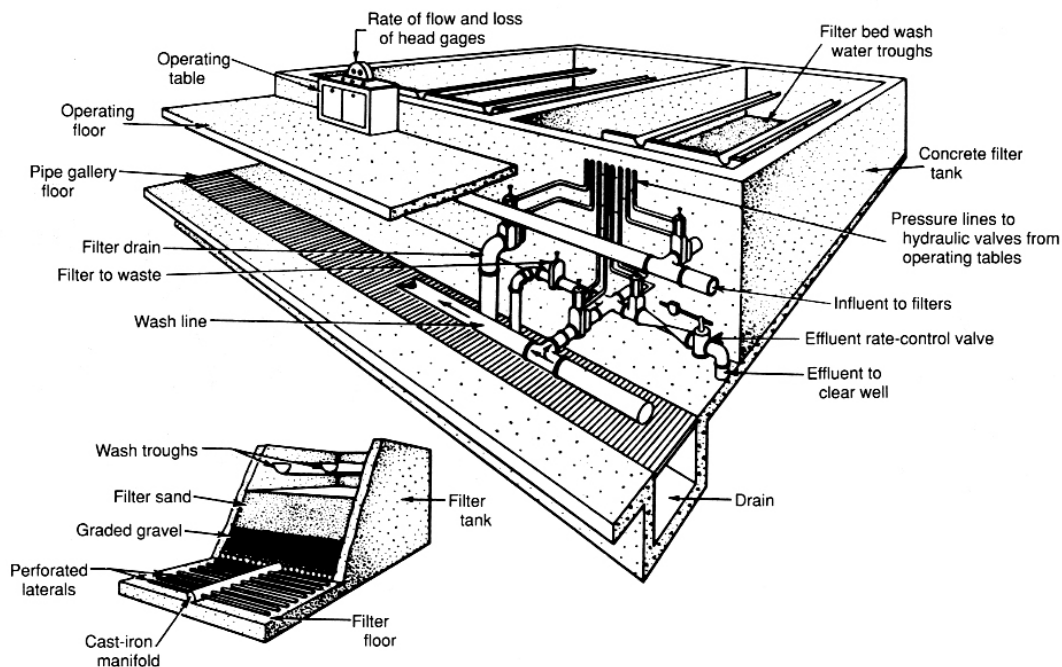

Figure 2.13 Rapid Sand Filter <sup>13</sup>

## Depth Filtration Type

- ✓ The medium used for depth filters is designed to allow the solids to penetrate into the filter medium. This provides a greater surface upon which to capture solids. Therefore, head loss will build more slowly than with a surface straining filter, and filter runs will be longer before backwash is required. However, because solids penetrate the filter medium, breakthrough of solids to the effluent can be problematic. Consequently, depth filters usually also contain a surface straining medium to minimize solids breakthrough.

## Dual Media Filters

These filters use two filter media with different characteristics:

- ✓ The coarse, less-dense medium, at the filter inlet, removes larger solids that would quickly blind the fine medium. It acts as a depth filter.
- ✓ A fine, denser medium, essentially surface strains solids that penetrate the coarse medium and prevent solids breakthrough.

## Multi-Media Filters

These filters are similar to the dual media filters but use multiple media types to affect filtration. A typical arrangement would include two types of depth filter media and a surface straining medium.

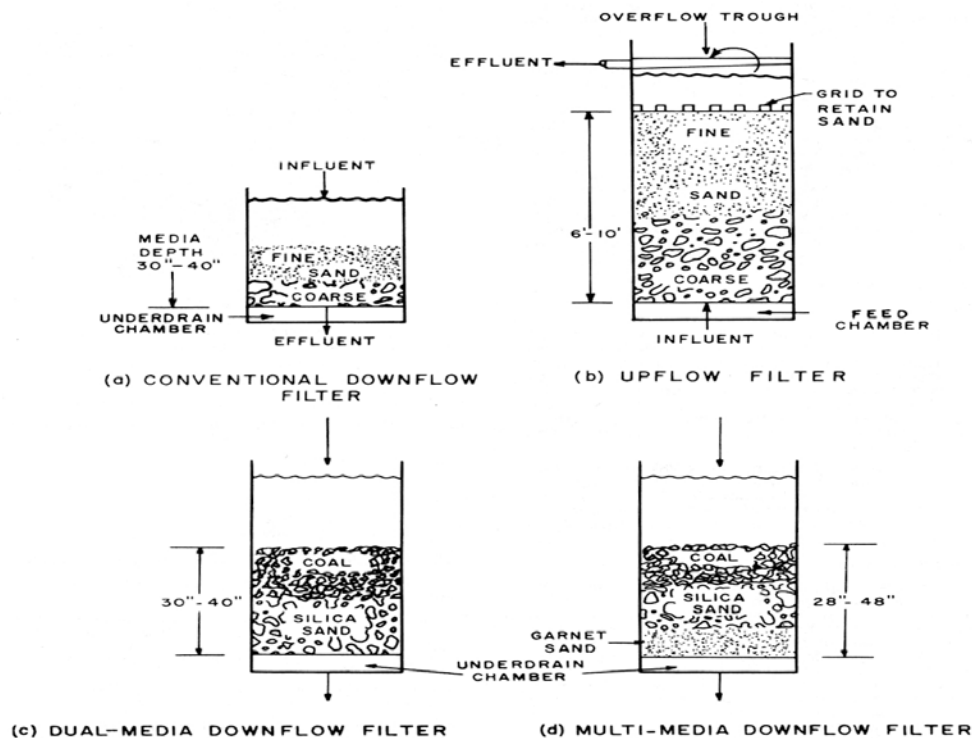

Figure 2.14 Filter Configurations<sup>14</sup>

## Major Parts of a Gravity Filter

This section highlights the major parts of a gravity filter and the basic function of each. Some of the material reinforces previous discussions.

### Inlet Distribution System

- ✓ Various arrangements are used to properly distribute influent evenly across the filter surface for more effective treatment. Uniform distribution is also important to avoid scouring the filter medium, which could occur from a single discharge point.

### Filter Media

- ✓ Various media types and filter flow configurations are used depending on the filtration application.
- ✓ Multimedia filters are typically used where higher solids loading is expected or where longer filter runs are necessary. Multimedia filters use more than one type of filter medium, which have differing sizes and densities.
- ✓ Surface straining filters are used where capture of solids and prevention of breakthrough are more critical. A typical surface straining filter medium is fine sand.

### Underdrain System

- ✓ The filter underdrain system is designed to contain the filter medium and help maintain a uniform flow through the filter during both filtering and backwash operations. Modern underdrain designs use the hollow block configuration to support the filter media and provide for distribution of water, both effluent and backwash.

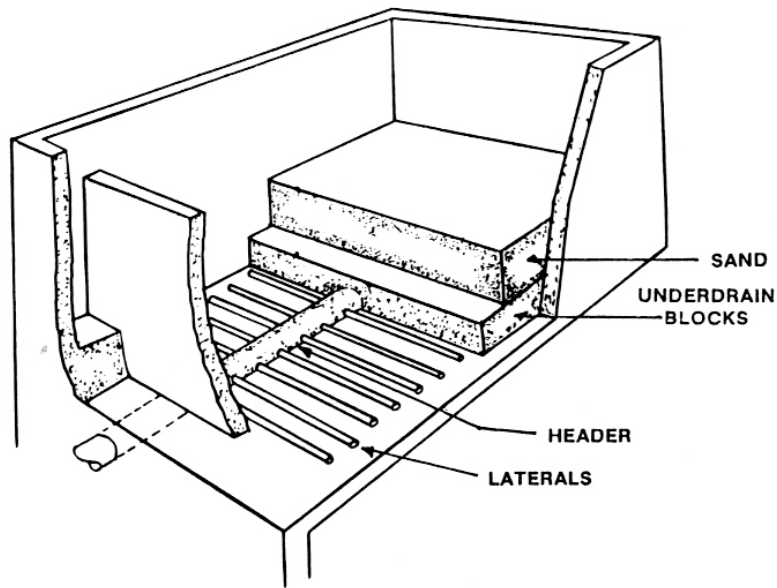

A. HEADER LATERALS  
(Courtesy of the AWWA)

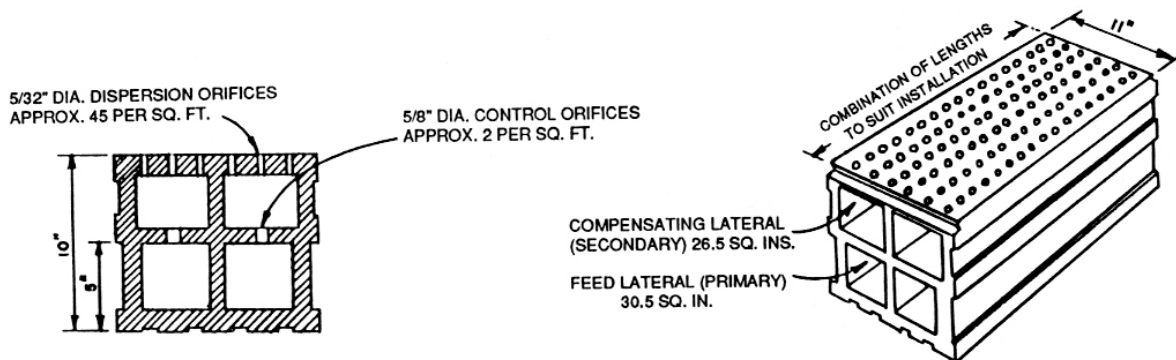

B. LEOPOLD BLOCK SYSTEM  
(Courtesy of F.B. Leopold Co.)

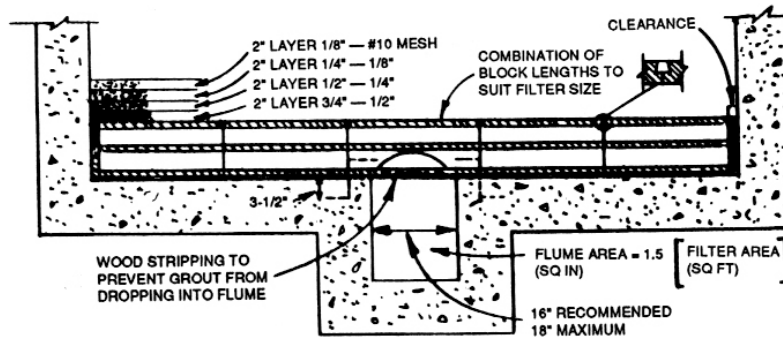

Figure 2.15 Underdrain System <sup>15</sup>

### Media Scouring System

- ✓ Incomplete cleaning of filter media during backwash can result in the eventual formation of mudballs within the filter.



The **mudballs** are agglomerations of solids, which, if not removed during backwash, will continue to grow in size and may plug underdrains or disrupt the filter configuration after the media settles following backwashing.

- ✓ Media scouring systems, often using air diffusers or water jets set at various depths in the filter, are effective in breaking up mudballs, but more importantly, they scour the filter media to help prevent the formation of mudballs in the first place.

### Effluent Rate Control Valve

- ✓ After entering the underdrain, the treated effluent might pass through a flow meter that controls a rate valve. This arrangement controls the flow through the filter within the desired range. This helps control the head loss through the filter and the quality of the effluent.

### Backwash System

Various configurations and equipment options are used for backwashing:

- ✓ Backwash Effluent Trough
  - Solids and backwash water are often removed from the filtration system via overflow troughs.
  - To be effective, the troughs should have sufficient capacity to carry the backwash water volume and solids, should be self-cleaning to the extent possible, should be set at the proper elevation, and be level to uniformly remove the backwash water and solids without creating dead spots.
- ✓ Backwash Holding Tank
  - Backwash water contains relatively high concentrations of solids and generally will be returned to the head of the treatment plant for reprocessing.
  - Due to the high flow rates used for backwashing, the backwash water could cause hydraulic overloading of the headworks. To avoid this, backwash-holding tanks might be needed to slowly release the backwash water to the headworks.
- ✓ Backwash Water Rate Control
  - The backwash water flow rate needs to be great enough to effect satisfactory solids removal without flushing the filter media out of the system.
  - The rate is generally controlled within a preset range, either by using pumps for backwashing or maintaining continuous adjustment of gravity-fed backwash water.

## Operational Considerations

This section is intended to highlight key operational considerations. For a more in-depth discussion of equipment operations the student should refer to manufacturers' operation and maintenance manuals and textbooks on this subject.

### Filter Loading Rate

- ✓ Observe the design loading rates suggested by the equipment manufacturers and as modified through experience with the equipment for the specific wastewater application. Excessive hydraulic rates may create solids breakthrough. Very low hydraulic rates may cause excessively longer filter runs that could cause matting on the filter surface (solids accumulation that is difficult to remove).

### Head Loss

- ✓ Maintain the head loss across the filter within the range suggested by the manufacturer. If an excessive head loss occurs too quickly, check: solids loading rate, hydraulic loading rate, flocculation effectiveness (examine the floc), and the underdrain for plugging (inadequate cleaning). If the head loss is too small, check: hydraulic loading rate, and for improper bed settlement.

### Backwash Effectiveness

- ✓ A complete cleaning is important to proper operation of the filter and prevention of mudball formation. If the optimal head loss range is exceeded too quickly, that might be an indication of improper cleaning. Another benefit of a thorough cleaning is that it may not be necessary to waste the initial filtered effluent following a thorough cleaning.

### Loss of Media

- ✓ Some loss of media can be expected over time. Inspection and/or sampling of backwash water can provide immediate insight into potential media loss. Also, periodic monitoring of the freeboard in the filter can provide an indication of potential media loss.



**Exercise**

1. When should a gravity filter be cleaned?

---

---

---

---

---

2. How is head loss through the filter media determined?

---

---

---

---

---

3. What can happen if the filter media is not thoroughly cleaned during each backwashing?

---

---

---

---

---

## Pressure Filtration Basics

- ✓ Pressure filters used for removing solids from secondary effluents operate similarly to gravity filters with the principal difference being the use of closed vessels so that pressure can be applied to force the wastewater through the filter media. The basic process is the same, in that an inert medium is used to capture solids, and chemical coagulants are used to enhance the removal of colloidal solids.
- ✓ As with gravity filtration, a method of controlling the flow through the filter must be provided
  - Because the head loss across the filter varies during the filtration process (due to the build-up of solids on the filter media) without a mechanism to control the flow rate the wastewater feed pumps would need to pump over a wide range of flow.
  - To control the flow rate, a rate control valve is used on the effluent header. When the filter is clean and the head loss through the filter is small, the rate control valve is throttled to increase the head loss and control the flow through the filter.
  - As solids collect on the media and the head loss increases, the rate control valve is manipulated to decrease the head loss through the valve. In this manner, the overall pressure loss through the filter can be stabilized at a preset value so that the flow through the filter will remain relatively constant.

## Major Parts of a Pressure Filter

With a few exceptions, the basic parts of a pressure filter are very similar to a gravity filter. The differences relate to the use of pressure versus gravity to affect the separation of solids from the wastewater.

### Influent Holding Tank

- ✓ Because the wastewater must be pressurized, it is typically collected in a holding tank or wet well for secondary effluent.
  - The tank may be configured like a clarifier so that additional solids can settle prior to filtration.
  - The tank also provides the wastewater volume necessary for the operation of the feed pumps.
  - Provisions are also made to by-pass the holding tank in the event the filtration system is down, and to remove floatable solids to the solids handling processes.



### Filter Feed Pumps

- ✓ The filter feed pumps lift and pressurize the secondary effluent as they transfer it through the filtration system.
- ✓ Instrumentation is required to manage the operation of the pumps because of the variable water level in the holding tank and the variable pressure across the filter.
  - Water level sensors in the holding tank may cycle the feed pumps on and off based on the wastewater level or they may be used to vary the pump speed based on the wastewater level.
  - Also, provisions are required to protect the pumps from pumping to the filter when the solids handling capacity has been reached. In this case, the pressure required to pump through the loaded filter could cause damage to the pumps, so a by-pass provision, to another filter or to discharge, must be available.

### Chemical Feed Systems

- ✓ The chemical feed systems discussed previously when reviewing gravity filters are also used with pressure filters.
- ✓ The same coagulants and flocculants may be used and similar equipment for feeding the chemicals is used. However, because the wastewater is transferred under pressure in this case, in-line mixing, rather than in-tank mixing, of both coagulant and flocculant must be used.
- ✓ Dosing control can be managed by using flow meters or based on the number of wastewater feed pumps operating.

### Filter

- ✓ For pressure filtration, a pressure vessel is required to contain the filter media. Typically a cylindrical vessel with dished heads will be used. The vessels design incorporates provisions for: access for media installation and maintenance; inlet and outlet pressure monitoring; pressure relief in the event of over pressurization; and air release during vessel filling and draining, and during operation.
- ✓ Interior piping is provided to distribute the influent uniformly across the filter face. Typically, a header arrangement with laterals is used. In addition, a filter surface wash system may be included, which is comprised of several laterals with high-pressure nozzles, possibly with a rotating mechanism.

- ✓ The underdrain system includes piping with a header and laterals to uniformly collect the filtered wastewater and a support medium for the inert filtering media. Typically, the underdrain support medium consists of a multi-layer gravel bed that allows the passage of filtered wastewater to the collection drain while also providing a support bed to hold the inert filter media in place.
- ✓ The filter media commonly used include silica sand, anthracite coal, and garnet sand. These media range in size and in density, and may be used individually as surface straining filters (silica or garnet sand) or combined to provide multi-media filtration. The media design selected is based on the filter application and the desired operating characteristics of the filter.

### Backwash System

- ✓ When the pressure loss through the filter reaches a predetermined value, the filter must be cleaned to prevent damage to the wastewater feed pumps, by-pass of the filter system, or breakthrough of solids to the effluent.
- ✓ As with gravity filtration, a backwash method is used to clean the solids from the filter media.
  - Backwash pumps are typically used to flush clean water in a reverse direction through the filter media. This action flushes and scrubs the solids from the media, and collection troughs remove the solids and backwash water from the filtration system.
- ✓ If possible, backwash operations will be scheduled during the plant's low-flow hours to minimize the wastewater holding requirements and because the backwash water will typically be returned to the head of the plant, "stealing" some of the capacity of the treatment plant.

### Backwash Decant Tank

- ✓ Because the flow rate of backwash water is high, decant tanks are often used to collect and hold the backwash waste prior to further processing of the water. Decant tanks, used to remove solids from the water by settling, may be used to equalize the flow of backwash water to the processing systems. Polymers may be injected at the decant tank to facilitate solids removal.

## Operational Considerations

This section is intended to highlight key operational considerations. For a more in-depth discussion of equipment operations the participant should refer to manufacturer's operation and maintenance manuals and textbooks on this subject.

### Filter Loading Rate

- ✓ Observe the design loading rates suggested by the equipment manufacturers and as modified through experience with the equipment for the specific wastewater application.
- ✓ Excessive hydraulic rates may create solids breakthrough. Very low hydraulic rates may cause excessively longer filter runs that could cause matting on the filter surface (solids accumulation that is difficult to remove).

### Head Loss

- ✓ Maintain the head loss across the filter within the range suggested by the manufacturer.
- ✓ If an excessive head loss occurs too quickly, check: solids loading rate, hydraulic loading rate (pumps), the effluent rate control valve for proper operation, flocculation effectiveness (examine the floc), and the underdrain for plugging (inadequate cleaning).
- ✓ If the head loss is too small, check: hydraulic loading rate (pumps), and for improper bed settlement.

### Chemical Feed Management

- ✓ Routine inspection and maintenance of the chemical feed system components is necessary for satisfactory operation of the equipment.
- ✓ Inspection and testing of the effectiveness of the chemicals and their proper dosing is necessary for optimum filtration and management of chemical feed costs.
- ✓ Proper storage of chemicals is important to prevent crystallization of chemicals (alum and sodium hydroxide) and damage to polymers from over mixing.

### Backwash Effectiveness

- ✓ A cleaning is important to proper operation of the filter and prevention of mudball formation. If the optimal head loss range is exceeded too quickly, that might be an indication of improper cleaning.
- ✓ Another benefit of a thorough cleaning is that it may not be necessary to waste the initial filtered effluent following a thorough cleaning.

### Backwash Water Management

- ✓ Proper management of backwash water can impact not only the backwashing process and proper operation of the filter, but can also impact other treatment plant operations.
- ✓ The following considerations should be evaluated at each facility:
  - An adequate supply of clean water for backwashing to ensure properly cleaned filters.
  - Storage and treatment of backwash water or backwash scheduling to minimize impacts on headworks or on chlorination facilities



**Exercise**

1. List the major components of a pressure filter system.

---

---

---

---

2. What is the purpose of the holding tank located just ahead of a pressure filter?

---

---

---

---

3. What could cause high operating filter differential pressures?

---

---

---

---

## Benefits of Continuous Backwash, Upflow, Deep-Bed Granular Media Filters

Continuous backwash, upflow, deep-bed granular media filters consistently produce a high quality, low turbidity effluent which reduces the demands on the disinfection system.

These filters continuously remove solids from the influent wastewater while at the same time cleaning the sand medium and returning it to service at the top of the filter. Therefore, these filters do not need to be taken out of service to be backwashed and consequently, these filters can operate continuously at their design flow rate. Therefore, fewer or smaller-sized filters can be used compared to conventional sand or multi-media filters.

## Filter System Components

Filter system components may be housed within factory-provided a tank, or the components may be installed in a concrete tank constructed on-site.

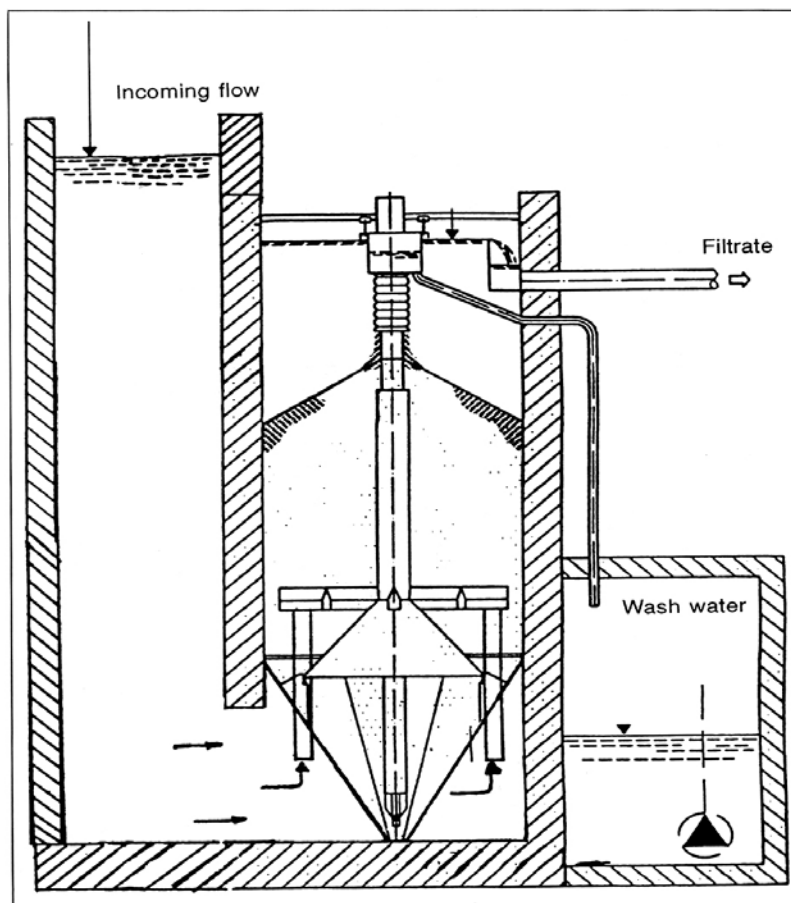

Figure 2.16 Bottom Feed Concrete Filter <sup>16</sup>

# CONTINUOUS BACKWASH, UPFLOW, DEEP-BED GRANULAR MEDIA FILTRATION

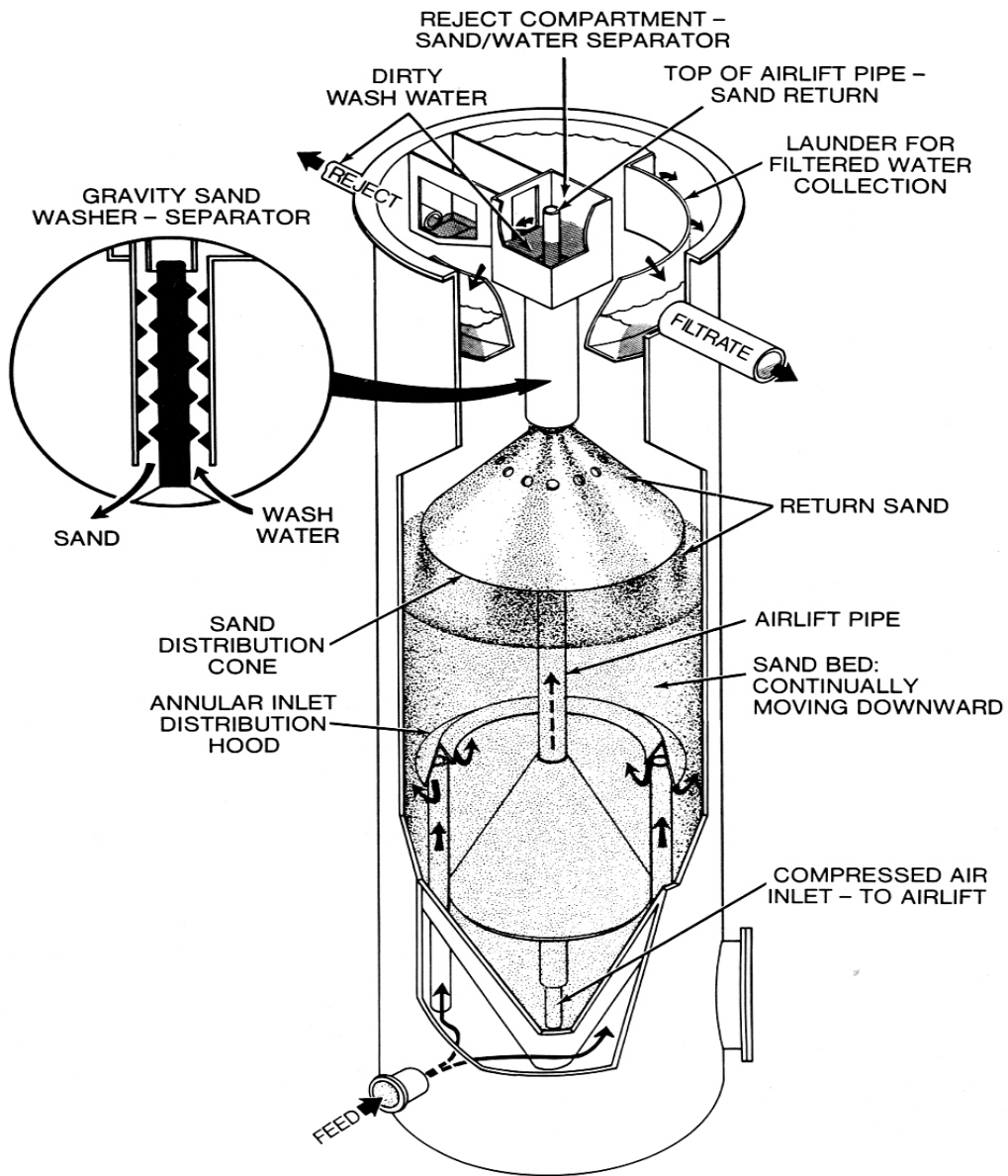

Figure 2.17 Bottom Feed Cylindrical Filter <sup>17</sup>

---

## **CONTINUOUS BACKWASH, UPFLOW, DEEP-BED GRANULAR MEDIA FILTRATION**

---

### **Chemical Feed Systems**

- ✓ Chemical feed pumps are generally used to meter chemical solutions at an accurate rate to the point of application.
  - These pumps can be provided with rate controllers that will allow the chemical to be metered at a rate that matches the demand for the chemical.
  - The demand can be determined by wastewater flow rate or some measurable characteristic of the treated wastewater.
  - Positive displacement pumps using a plunger or a diaphragm are typically used for liquid chemical feed.
- ✓ The length of the stroke and the stroke frequency can be adjusted manually or automatically to vary the chemical feed rate.
- ✓ Screw feeders are commonly used to meter solid chemicals to solution tanks or the point of application.
- ✓ The feed rate is adjusted by varying the screw rotation rate. Other solid chemical feeder designs are also used.

### **Flocculation Tank**

- ✓ A flocculation tank with a slow-speed mixer is used to enhance the development of large floc particles in the wastewater. The flocculant is typically added in-line prior to the flocculation tank.

### **Influent Distribution System**

- ✓ Piping is used to conduct the influent wastewater from the filter bottom to the filtration medium. A distribution ring is commonly used to apply the wastewater uniformly across the face of the filter medium.

### **Influent and Effluent Turbidity Monitoring**

- ✓ Influent and effluent turbidity monitoring may be used to provide a continuous record of the filter performance.



## CONTINUOUS BACKWASH, UPFLOW, DEEP-BED GRANULAR MEDIA FILTRATION

### Influent and Effluent Flow Metering

- ✓ Dosage control for the chemical feed systems may be managed by influent and effluent wastewater flow meters. These meters also provide a time-variable record of the flow to the filters.

### Continuous Backwash System

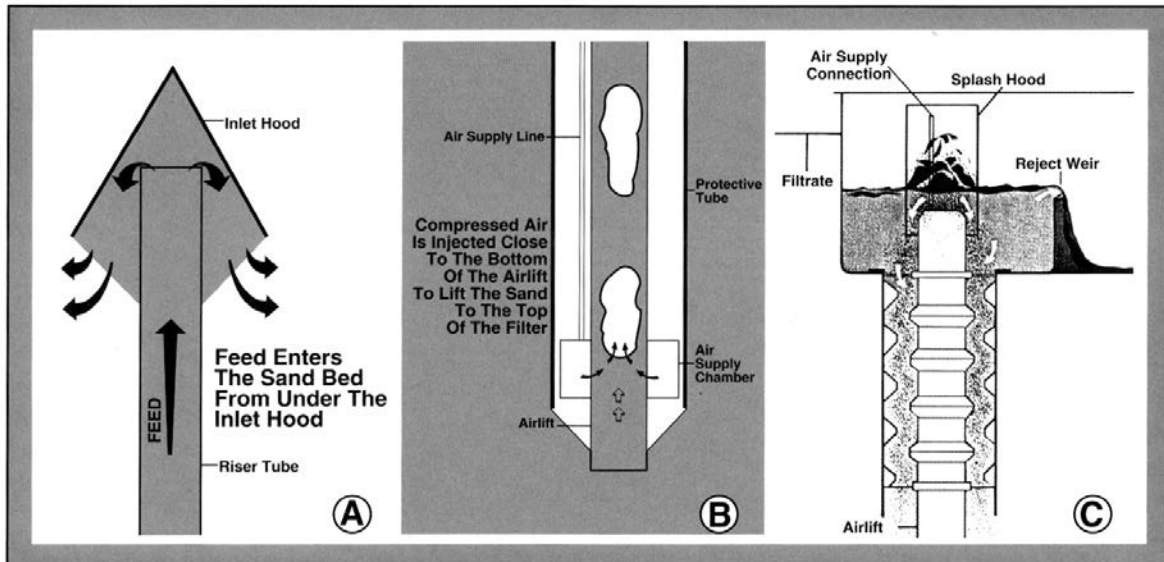

Figure 2.18 Internal Details of the Continuous Backwash System, Plates B and C <sup>18</sup>

- ✓ Spent sand is continuously removed from the bottom of the filter using an air-lift pump and carried to the top of the filter to the sand/water separator.
- ✓ In the separator, dirty wash water overflows a weir to a dirty backwash water sump or tank, and sand is allowed to fall back down to the top of the sand bed, but it must pass through a baffled launder mechanism to do so.
- ✓ In the launder, which is similar to an in-line mixer, the downward falling sand encounters upward flowing filtered water that cleans the sand during its downward migration. Consequently, the sand is returned to the top of the bed in a cleaned condition, and the upward flowing water carries solids to the reject compartment where the dirty water and solids overflow a weir and discharge to the dirty backwash water sump or tank.

### Backwash Water Sump

- ✓ Reject water containing dirty water and solids leaves the filter system and is discharged to a holding sump or tank. From this sump, the dirty water and solids are generally returned to the headworks for treatment.

## Operational Considerations

As with other filtration systems it is important to maintain the proper solids and hydraulic loading rate to the filter, to monitor the performance of the filter system, and to maintain the proper chemical dosing rate for optimum treatment. However, there are some unique operational considerations pertinent to a continuous backwash upflow, deep-bed granular media filter.

### Air Lift Pump

- ✓ The airlift pump must be operating whenever wastewater is being processed through the filter, otherwise the sand in the filter will not get cleaned and solids will quickly plug the filter.
- ✓ Conversely, the air-lift pump must not be operated if no influent is being processed because no wash water will be provided to clean the dirty sand pumped to the top of the filter, so dirty sand will be returned to the top of the sand bed which will adversely impact the effluent quality when the filter is operated normally.
- ✓ There is a design range (between 100 SCFM and 150 SCFM) for pumping sand through the airlift to achieve optimum cleaning. If the pumping rate is too slow, the sand will not be cleaned quickly enough and solids will begin to accumulate in the filter, adversely impacting filter performance.
- ✓ The pumping rate for the sand should be adjusted within the design range so that the head loss for the wastewater flowing through the filter system remains relatively stable. If the head loss increases, the air lift pumping rate may be too slow; and if the head loss decreases, the air lift pumping rate may be too fast. An operating log should be maintained so that the head loss, pumping rate, and other filter process parameters can be properly monitored and controlled.

### Controlling Reject Water Flow Rate

- ✓ The flow of reject water over the weir must be within the design range (10 to 15 gallons per minute) to properly remove solids from the filter. If the rate is too low, solids will not be properly and permanently removed from the filter, so only partially cleaned sand will be returned to the top of the filter bed. This will adversely impact the filter performance.

# CONTINUOUS BACKWASH, UPFLOW, DEEP-BED GRANULAR MEDIA FILTRATION



## Exercise

1. What happens if the air lift is allowed to operate without wastewater flowing to the filter?

---

---

---

---

2. What are the advantages of continuous backwash, up-flow, deep-bed silica sand media filters over other types of granular media filters?

---

---

---

---

3. How is silica sand media cleaned in a continuous backwash, up-flow, deep-bed silica sand media filter?

---

---

---

---

**The Basics of Membrane Filtration**

Cross flow membrane filtration is an alternative process for separating solids from a liquid phase. The process uses a membrane, rather than a granular medium, to prevent the passage of solids to the effluent stream. When wastewater under pressure is applied to a membrane filter, water permeates through the membrane as the wastewater containing solids passes along the length of the membrane. Consequently, the concentration of solids increases as the wastewater flows along the length of the membrane. One possible membrane filtration schematic is shown in the following figure:

**CROSS FLOW MEMBRANE FILTRATION  
Wastewater Process Schematic**

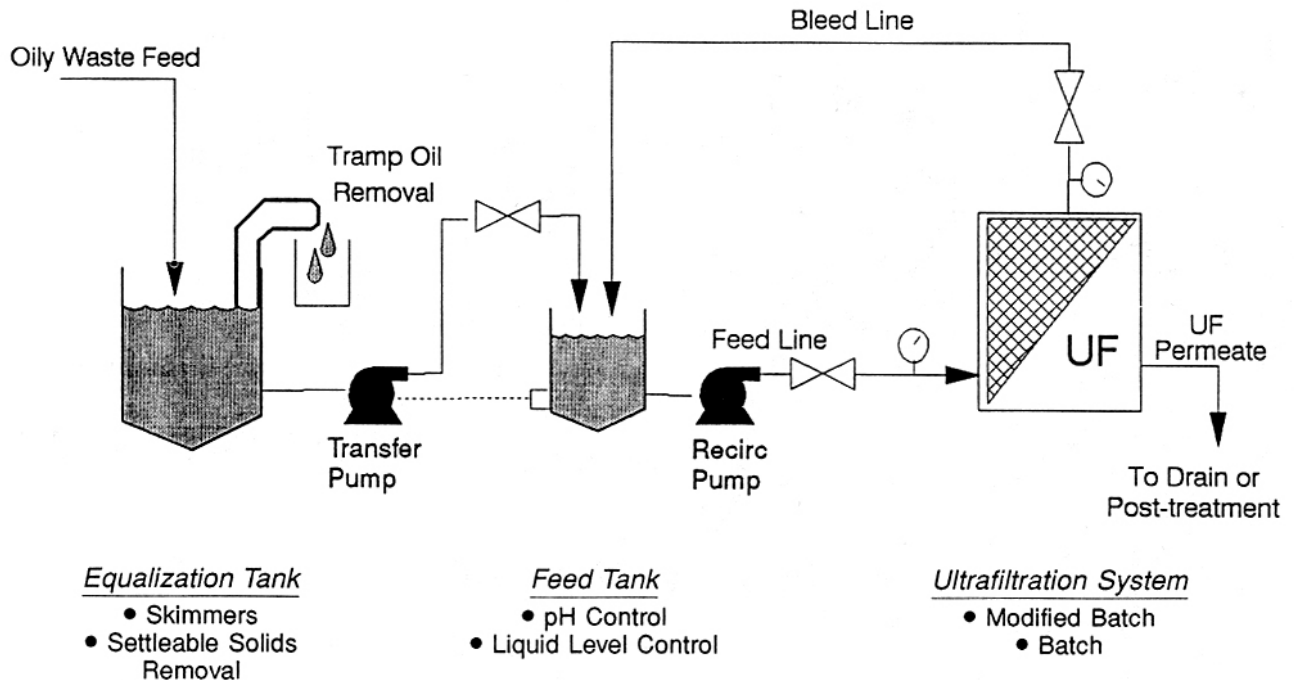

Figure 2.19 Typical Ultrafiltration Wastewater Treatment Flow Schematic <sup>19</sup>

The membrane provides a physical barrier to the passage of solids, and even to the passage of large molecules. The size of the molecules that are able to cross the membrane can be selected based on the characteristics of the membrane.

### Types of Membrane Filters

Membranes can be constructed of various materials and with various characteristics. A simple distinction is to differentiate membranes based on the size of the molecules they pass. On this basis there are a few significant membrane processes: microfiltration, ultrafiltration, nanofiltration, and reverse osmosis. These processes are gaining favor for industrial wastewater pretreatment applications. Highlights of these processes are presented below.

#### Microfiltration

- ✓ Microfiltration membranes have pores that range in size from 0.1 to 2.0 microns (which is relatively large).



A **micron** is one-millionth of a meter.

- ✓ Because of the relatively large pore size, this process is more suitable for production processes rather than for wastewater treatment processes. The large pores let too much wastewater contamination through the membrane.

#### Ultrafiltration

- ✓ Ultrafiltration is the most commonly used membrane for wastewater treatment applications. It uses a membrane with pore sizes ranging from 0.005 to 0.1 micron. Emulsified oils, metal hydroxides, proteins, and starches are larger than the pore size and will not pass through the membrane.

#### Nanofiltration

- ✓ The pores for a nanofilter are so small that they will allow only small molecules, such as salts, to pass, but will retain larger molecules, such as sugars and nitrogen molecules. These larger molecules create BOD and COD in wastewaters, and therefore nanofiltration is effective in reducing the BOD of wastewater by removing these molecules.
- ✓ There is a trade-off between small pore size and solids handling capacity. Nanofilters may not be efficient for many wastewaters because the amount of solids present may require a disproportionately long time for cleaning.

## Reverse Osmosis

- ✓ The tightest membranes are used in reverse osmosis, which only allows very small molecules such as water to pass. Most solids, even salts, are retained on the membrane. Because of the small size of the pores, reverse osmosis has limited solids handling capability, so the process is most often used following a coarser filtration process, such as ultrafiltration and only when very high quality water is required.

### PARTIAL LIST OF STANDARD MEMBRANES

#### REVERSE OSMOSIS

Membrane Type	Molecular Weight Cut-Off (Daltons)				Configuration
	10	100	1,000	10,000	
KMS-CA					Tubular

#### ULTRAFILTRATION

Membrane Type	Molecular Weight Cut-Off (Daltons)				Configuration
	1,000	10,000	100,000	1,000,000	
HFK-328					Spiral
HFK-434					Spiral
HFK-131					Spiral
HFM-100					Spiral, Tubular
HFM-116					Spiral
HFM-251					Spiral, Tubular
HFP-276					Tubular
HFM-183					Spiral, Tubular

#### MICROFILTRATION

Membrane Type	Pore Size (Microns)			Configuration
	0.1	1.0	10.0	
MMP-603				Spiral
MMP-613				Spiral
MMP-601				Spiral
MMP-615				Tubular
MMP-600				Spiral
MMP-617				Tubular
MMP-602				Spiral

Figure 2.20 Cross Flow Membrane Filtration <sup>20</sup>



What experiences have you had with any of the membrane filters listed above?

---

---

---

---

---

## Membrane System Configurations

Membranes are constructed in various configurations and are housed in a variety of materials. A few examples are discussed below.

### Tubular Membranes

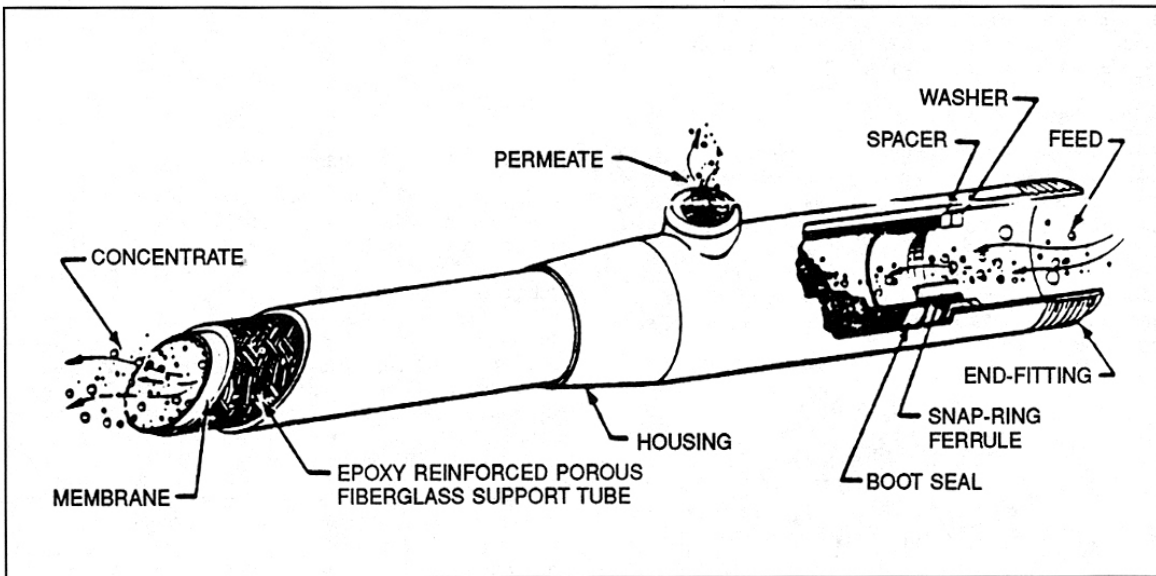

Figure 2.21 FEG one-inch tube <sup>21</sup>

- ✓ As shown in the graphic, membranes can be applied to plastic and steel piping so that the membrane covers the inside diameter and length of the piping. This is a rugged arrangement that allows the solids to travel along the length of the pipe as water permeates through the membrane and exits through the side of the pipe.

### Hollow Fiber Membranes

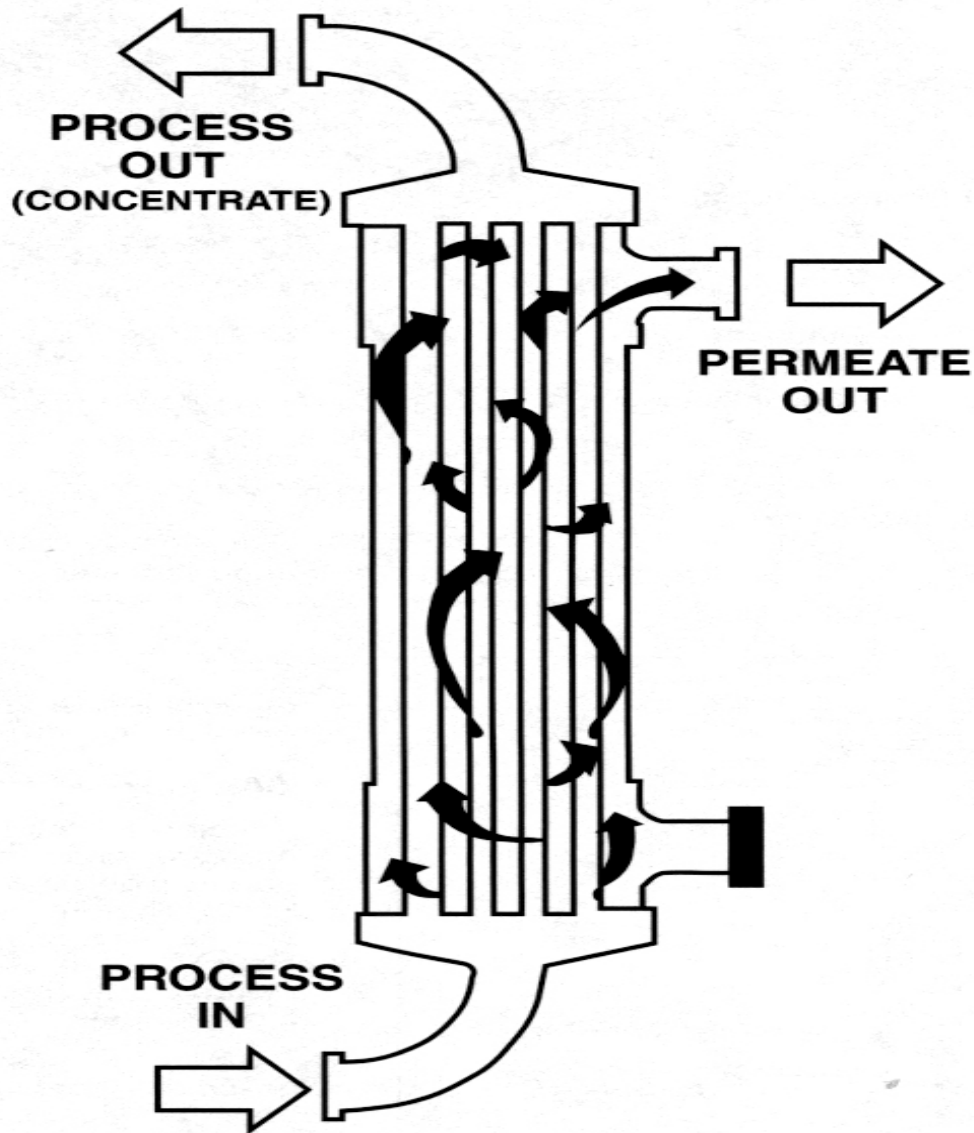

Figure 2.22 Hollow Fiber Cartridge <sup>22</sup>

- ✓ Hollow fiber membranes are thin tubes of membrane polymer, with the membrane surface normally on the inside of the hollow fiber. The fibers are closely packed in a support structure so that a high density of membrane is created. This allows for a relatively high permeate rate and is an economical membrane configuration.
- ✓ Another advantage of this configuration is that the membranes can be backwashed by causing permeate to flow in the reverse direction, which flushes out accumulated solids.



## Spiral Membranes

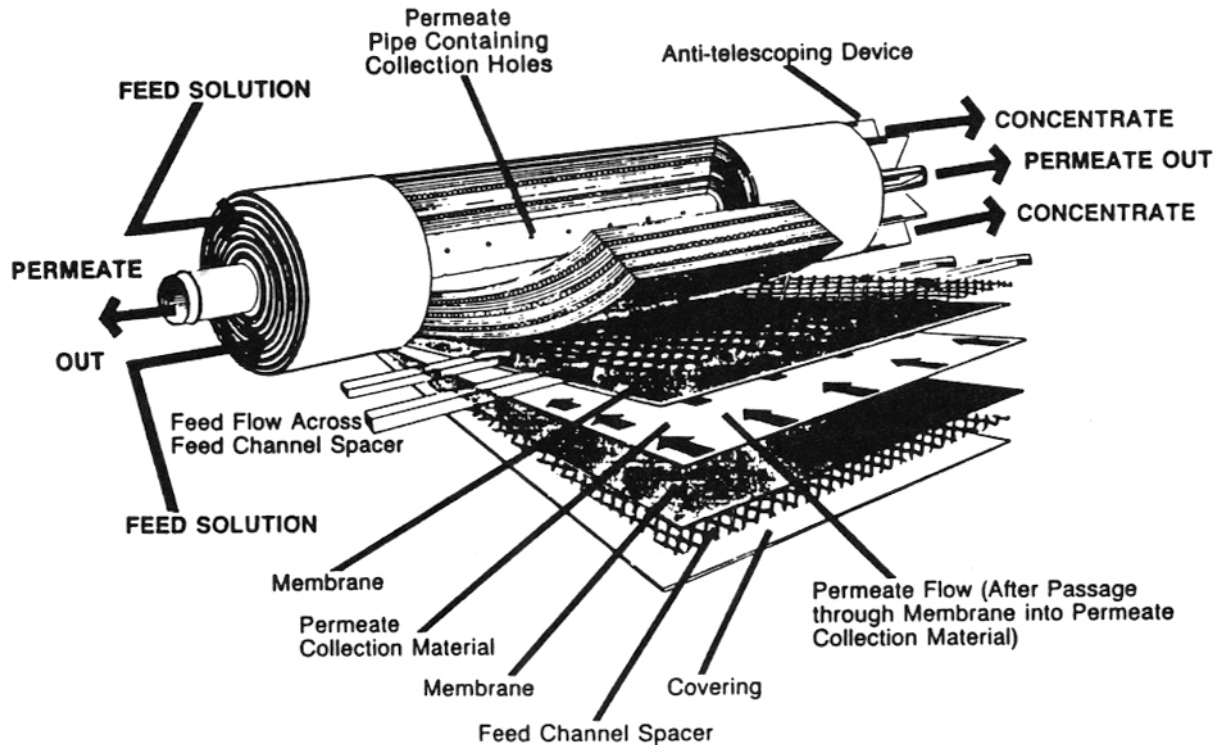

Figure 2.23 Spiral Wound Module <sup>23</sup>

- ✓ A spiral module is composed of a flat sheet membrane, a permeate carrier, a feed spacer, and glue to isolate the feed from the permeate. Spiral membranes are capable of packing a large surface area into a small space. However, they have limited solids handling capability so require the most effective pretreatment.

### The Membrane Filtration Process

Membrane systems remove solids and other wastewater contaminants from the wastewater, producing a relatively clean water effluent. In the process, the concentration of solids and other contaminants remaining in the wastewater that does not cross the membrane is increased significantly. If the volume of wastewater is reduced 20- to 100-fold by membrane filtration, the concentration of solids in the unfiltered wastewater may be as high as 60 percent.

#### Terminology



**Permeate** is the water that crosses the membrane and is the effluent from the process.



**Concentrate** (or retentate) is the wastewater that does not cross the membrane and is the waste product of the process (containing solids and other contaminants).



**Transmembrane pressure** is the pressure differential across the membrane. This is the driving force that creates the permeate.



**Flux** is the amount of permeate flow per unit area of membrane. The flux is dependent on a number of variables including: transmembrane pressure, wastewater flow rate, contaminant concentration, temperature, viscosity, and cleanliness of the membrane.



**Retention** is the effectiveness of the membrane in preventing contaminants from crossing the membrane, and is generally expressed as a percentage.



**Recirculation** is the wastewater that passes through the filter without crossing the membrane. After passing through the system it is returned to the feed tank and recirculated back through the membrane filter. This process continues until the concentration of the recirculation stream reaches a limiting value.

CROSS FLOW MEMBRANE FILTRATION

Industrial Wastewater Ultrafiltration 8-in-Series One-Inch Tubular Arrangement

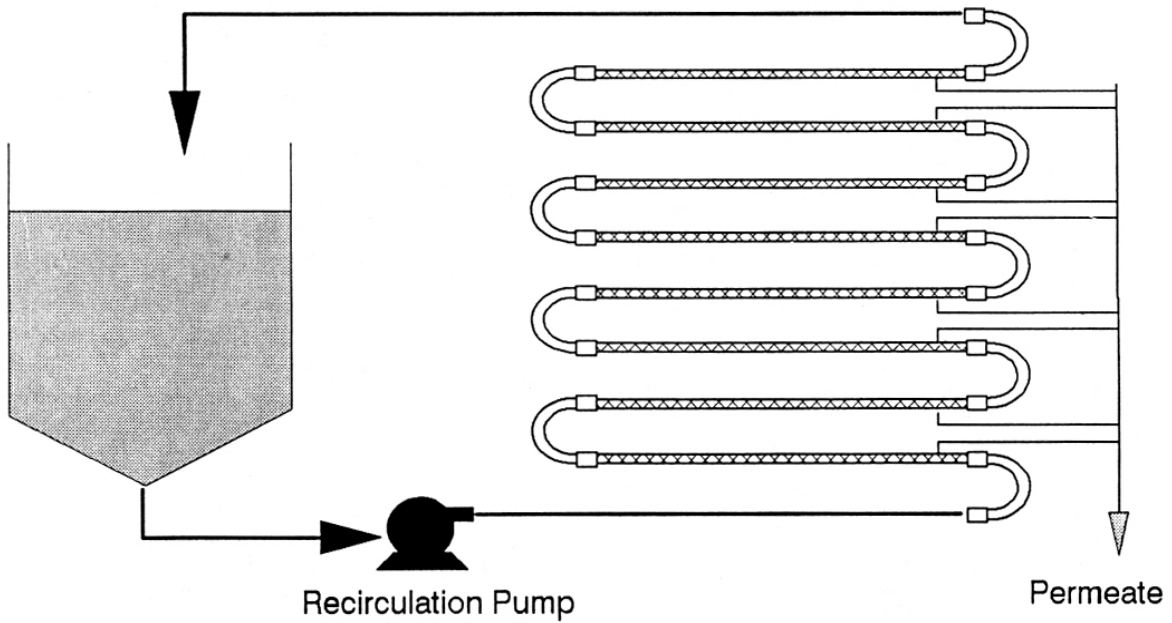

CROSS FLOW MEMBRANE FILTRATION

Batch Process

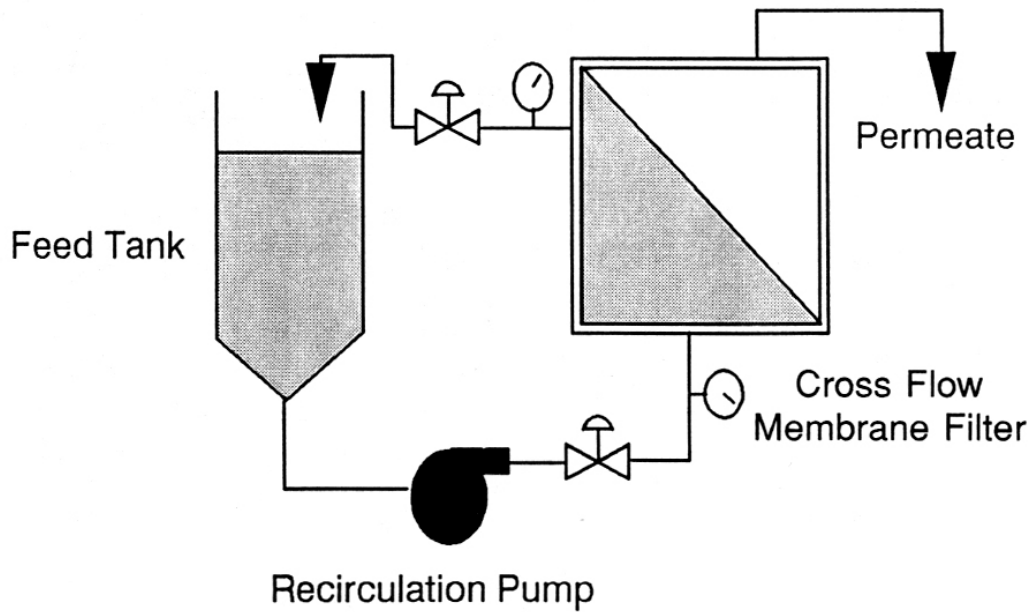
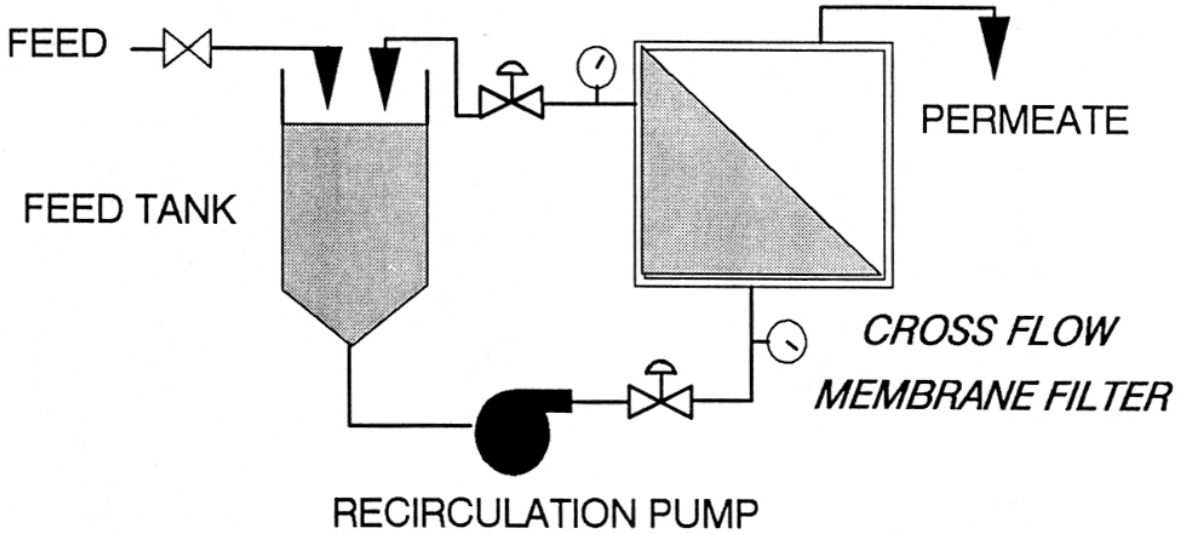

Figure 2.24 Tubular Arrangement and Batch Process <sup>24</sup>

**CROSS FLOW MEMBRANE FILTRATION  
Modified Batch Process**



**CROSS FLOW MEMBRANE FILTRATION  
Stages-in-Series Process**

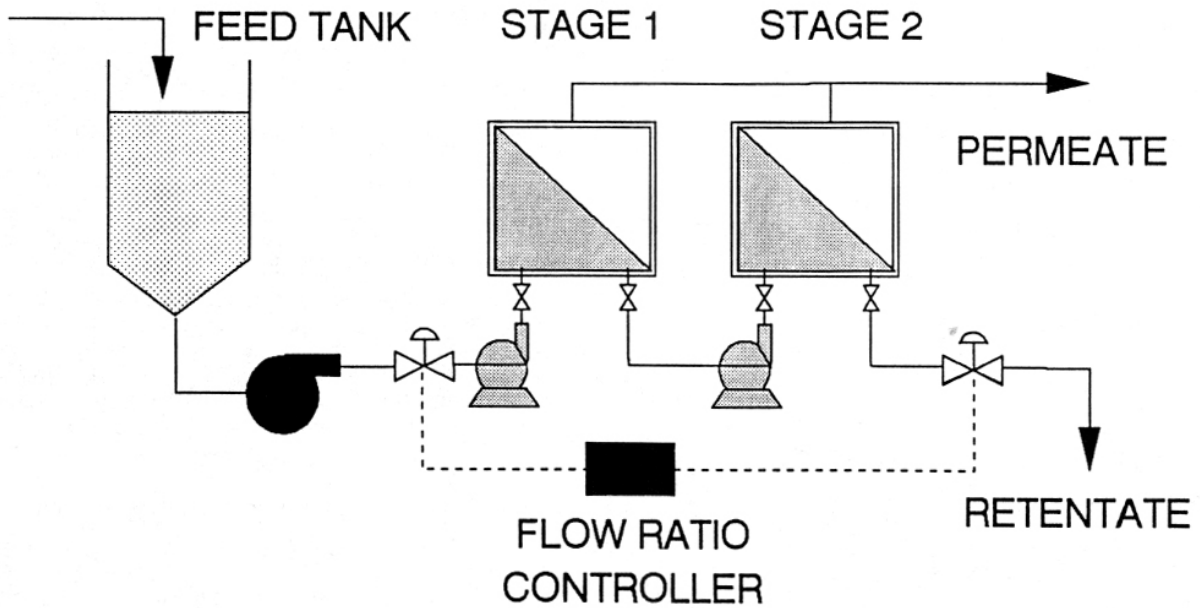

Figure 2.25 Modified Batch Process and Stages in Series Process <sup>25</sup>

### Basic Calculations

Retention =  $1 - (\text{Permeate concentration of component} / \text{Concentrate concentration of component})$

Flux =  $\text{Permeate Flow Rate} / \text{Membrane Area}$       units are gallons per square foot per day

Transmembrane pressure =  $[(\text{Inlet Pressure} - \text{Outlet Pressure}) / 2] - \text{Pressure of Permeate}$

Feed Volume =  $\text{Permeate Volume} + \text{Concentrate Volume}$



Refer to pages 424 and 425 of *Advanced Waste Treatment*, 3<sup>rd</sup> Edition and do the sample calculations identified by your instructor.

### Operational Considerations

Membrane filtration systems require proper pretreatment of the feed to prevent fouling or plugging of the system. In addition, several process parameters are important to the proper functioning of a membrane filter and are worthy of discussion.

#### Temperature

- ✓ Temperature affects membrane filtration because the viscosity of fluids is inversely related to temperature (the higher the temperature the smaller the viscosity). Therefore, operating at the upper end of the allowable temperature range will optimize the performance of a membrane filtration system.
- ✓ However, temperatures exceeding the design range will likely damage and may destroy the membrane. Consult the manufacturer's instructions to determine the appropriate operating temperature for the specific membrane used.

#### Flux

- ✓ Membrane filtration systems are generally designed to achieve a specified flux rate. This design takes into account the variables that affect the flux of a system (as discussed above).
- ✓ Deviation from the design flux generally indicates a problem with the system or a change in the influent characteristics from the design values. The problems could entail a drop in transmembrane pressure or a reduction in the recirculation flow rate (due to potential pump problems), or fouling or plugging of the membrane surface (indicating that cleaning is required).

#### Transmembrane Pressure

- ✓ For ultrafiltration, the transmembrane pressure is typically in the range of 20 to 80 pounds per square inch (PSI) and for reverse osmosis is in the range of 400 to 1,000 PSI.
- ✓ Flux is a function of transmembrane pressure up to a point where the wastewater concentration becomes great enough to negate the effect of transmembrane pressure on flux.

#### Differential Pressure of the Recirculation Flow

- ✓ The differential pressure of the recirculation flow is a measure of the pressure drop from the inlet of the membrane system (at the pump discharge) to the outlet of the membrane system (where the recirculation flow leaves the system). This pressure drop is generally related directly to the recirculation flow rate through the membrane system and is a simple pipe flow head loss relationship.

- ✓ Changes in the influent characteristics or build-up of solids on the membrane can cause changes in the differential pressure. Deviations from the normal differential pressure should be investigated immediately as an indication of potential major problems with the system.

### Membrane Fouling



**Fouling** is a molecular attraction between contaminants in the feed with the membrane material.

- ✓ Reversible fouling is expected for all membrane and can be managed with routine cleaning.
- ✓ Irreversible fouling, though rare, can also occur. In this case, contaminants that are not compatible with the membrane material react with the membrane so that they cannot be cleaned off or removed. Consult manufacturer's literature for the specific membrane material to identify potential irreversible fouling contaminants.

### Cleaning Options

- ✓ Cleaning of membranes is a routine procedure that may need to be performed on a weekly or semi-weekly basis, depending on the process characteristics. A cleaning cycle typically takes approximately two to four hours to complete.
- ✓ The cleaning cycle includes:
  - Displacement of wastewater from the system with clean water.
  - Circulation of a warm, caustic surfactant solution through the system.
  - Flushing the system with warm water after the wash cycle is completed.
  - Washing the system with a warm, dilute acid cleaner to remove accumulated salts.
  - Flushing again with warm water.
  - Checking and recording flux rate using clean water.
- ✓ Exposure of membranes to aggressive cleaning solutions contributes significantly to their degradation, so cleaning solutions should be carefully prepared to minimize damage to the membrane while still completing the necessary cleaning function.
- ✓ Tubular systems can be mechanically cleaned as well as chemically cleaned. To perform a mechanical cleaning, sponge balls sized for the tube diameter are flushed through the system.
- ✓ Hollow fiber systems can be mechanically cleaned by backwashing the membrane with clean water. However, most tubular and spiral membrane systems cannot be backwashed do to delamination of the membrane from the support.



## Key Points for Unit 2 – Effluent Polishing

- Today's strict discharge requirements often require the treatment plant to provide additional facilities beyond secondary treatment.
- Physical-chemical treatment is a three-step process consisting of coagulation, flocculation, and liquids/solids separation.
- Typical filtration technologies include: gravity, pressure, upflow and membrane filtration.
- Polymers are generally used to facilitate the flocculation process. The long-chain polymer molecules wrap around several coagulated particles creating larger and denser particles that will separate readily from the wastewater.
- Polymers can be difficult to dissolve and require extra care when preparing solutions. Generally, polymers need to age before their full effectiveness is achieved.
- Jar tests are used to conduct a simultaneous evaluation of several chemicals or several chemical dosages.
- Coagulant mixing tanks have a short detention time and a high rate mixing regime to introduce the chemical, create a homogeneous solution, and create intimate contact between the fine particulates to cause coagulation.
- Generally, the flocculating time will be five to 10 times longer than the coagulating time.
- Conventional sedimentation clarifiers are generally used for solids separation.
- It is good practice to maintain enough spare parts as necessary to keep the system running.
- Most filtration systems operate on a batch basis. This means that wastewater is applied to the filter until its solids handling capacity is reached. At that point, the head loss through the filter, caused by the accumulated solids, becomes excessive and the filter must be cleaned using a backwash procedure.
- Typical gravity filtration alternatives include surface straining, rapid sand filters, depth filtration type, dual media filters, and multi-media filters.
- Pressure filters used for removing solids from secondary effluents operate similarly to gravity filters with the principal difference being the use of closed vessels so that pressure can be applied to force the wastewater through the filter media.
- Continuous backwash, upflow, deep-bed granular media filters consistently produce a high quality, low turbidity effluent which reduces the demands on the disinfection system.
- Cross flow membrane filtration is an alternative process for separating solids from a liquid phase. The process uses a membrane, rather than a granular medium, to prevent the passage of solids to the effluent stream.
- Types of membrane filters include microfiltration, ultrafiltration, Nanofiltration and reverse osmosis.
- Some key operational considerations for using membrane filtration systems include temperature, flux, transmembrane pressure, differential pressure of the recirculation flow, membrane fouling and cleaning options.





**Exercise**

1. How do cross flow filtration processes differ from conventional filtration?

---

---

---

---

2. The amount of flux across a membrane is dependent on what factors?

---

---

---

---

3. List the steps for cleaning (washing) a membrane.

---

---

---

---

<sup>1</sup> Paul Amodeo, Ross Gudgel, James L. Johnson, Paul J. Kemp, Robert G. Blanck and Francis J. Brady, "Chapter 4: Solids Removal from Secondary Effluents," in *Advance Waste Treatment*, (Sacramento, CA: California State University, Sacramento Foundation, 1998), p. 321.

<sup>2</sup> Amodeo, p. 325.

<sup>3</sup> Amodeo, p. 327.

<sup>4</sup> Amodeo, p. 340.

<sup>5</sup> Amodeo, p. 339.

<sup>6</sup> Amodeo, p. 342-343.

<sup>7</sup> Amodeo, p. 344.

<sup>8</sup> Amodeo, p. 353.

<sup>9</sup> Amodeo, p. 354.

<sup>10</sup> Amodeo, p. 355.

<sup>11</sup> Amodeo, p. 358.

<sup>12</sup> Amodeo, p. 370.

<sup>13</sup> Amodeo, p. 373.

<sup>14</sup> Amodeo, p. 368.

<sup>15</sup> Amodeo, p. 374.

<sup>16</sup> Amodeo, p. 401.

<sup>17</sup> Amodeo, p. 402.

<sup>18</sup> Amodeo, p. 408.

<sup>19</sup> Amodeo, p. 430.

<sup>20</sup> Amodeo, p. 418.

<sup>21</sup> Amodeo, p. 420.

<sup>22</sup> Amodeo, p. 421.

<sup>23</sup> Amodeo, p. 422.

<sup>24</sup> Amodeo, p. 428.

<sup>25</sup> Amodeo, p. 429.

---

---

# Unit 3 – Phosphorus Removal

---

---

## Learning Objectives

- Identify two distinct technology options for removing phosphorus from wastewater.
- Describe each of the following processes, list the equipment required for each process and identify the operational considerations for each:
  - Biological Phosphorus Removal
  - Phosphorus Removal by Lime Precipitation
  - Phosphorus Removal by Alum Flocculation

## Why Remove Phosphorus

Phosphorus is an essential nutrient for algae growth. The discharge of phosphorus, along with other essential nutrients, stimulates algae growth in the streams receiving the wastewater discharge. Algae causes taste and odor problems, is aesthetically unpleasing and most importantly, creates enormous oxygen demand when algal bloom dies off. Depletion of oxygen caused by the dying algal blooms is responsible for fish kills and other significant disruptions of the aquatic environment. For these reasons, regulatory agencies often regulate the amount of phosphorus allowed in wastewater discharges.

## Technology Options for Phosphorus Removal

The most common methods for removing phosphorus from wastewater are biological removal and chemical precipitation. These processes are typically implemented following secondary treatment, such as activated sludge treatment, and are therefore referred to as tertiary treatment. There are other methods to remove phosphorus from wastewater, but the focus of this module is biological and chemical removal in tertiary treatment processes.

### Biological Phosphorus Removal

- Microorganisms found in conventional activated sludge systems remove phosphorus from wastewater and incorporate it into their cell structure.
- An effective biological phosphorus removal system can be created by transferring the microorganisms back and forth between controlled environments that first forces them to release phosphorus from their cells and then induces them to absorb more phosphorus than they normally would.

### Chemical Phosphorus Removal

Two chemical processes are commonly used to remove phosphorus from wastewater: lime precipitation and alum flocculation and precipitation.

- During lime treatment for phosphorus removal, an excess of lime is added to the wastewater causing phosphorus to form a precipitate with calcium hydroxide. This precipitate can be flocculated and removed from the wastewater by settling.
- When alum (aluminum sulfate) is added to wastewater, a precipitate of aluminum phosphate forms. Aluminum phosphate is not a dense precipitate and requires flocculation with a polymer, and often filtration to achieve adequate removal of the precipitate.

### How the Process Works

Biological phosphorus removal is accomplished by transferring microorganisms back and forth between two distinct treatment environments.

- One treatment tank provides an abundant supply of food and oxygen, encouraging the microorganisms to absorb constituents from the wastewater, especially phosphorus.
- The other treatment tank provides an anaerobic environment (no oxygen) and very little food, which causes the microorganisms to use their own cell mass for food and energy. Phosphorus is released from the microorganisms' cells in this anaerobic tank.
  - This also means that the presence of dissolved oxygen inhibits the release of phosphorus.

### Luxury Uptake of Phosphorus

- Luxury uptake of phosphorus occurs in a modification of the basic activated sludge process. The modification uses an anaerobic tank to condition the microorganisms.
- After spending time in the anaerobic tank, the microorganisms' bodies contain a depleted amount of phosphorus because they needed to use the phosphorus for survival.
- Luxury uptake of phosphorus occurs when the microorganisms from the anaerobic tank are transferred to an aerobic tank with plenty of food. As a reaction to being depleted of phosphorus, the microorganisms in the aerobic tank absorb more phosphorus than their bodies require. This is referred to as luxury uptake.
- As the process is repeated, the phosphorus absorbed by the microorganisms in the aerobic tank is released in the anaerobic tank, and the microorganisms are again conditioned to want an excess amount of phosphorus when they are returned to the aerobic tank.

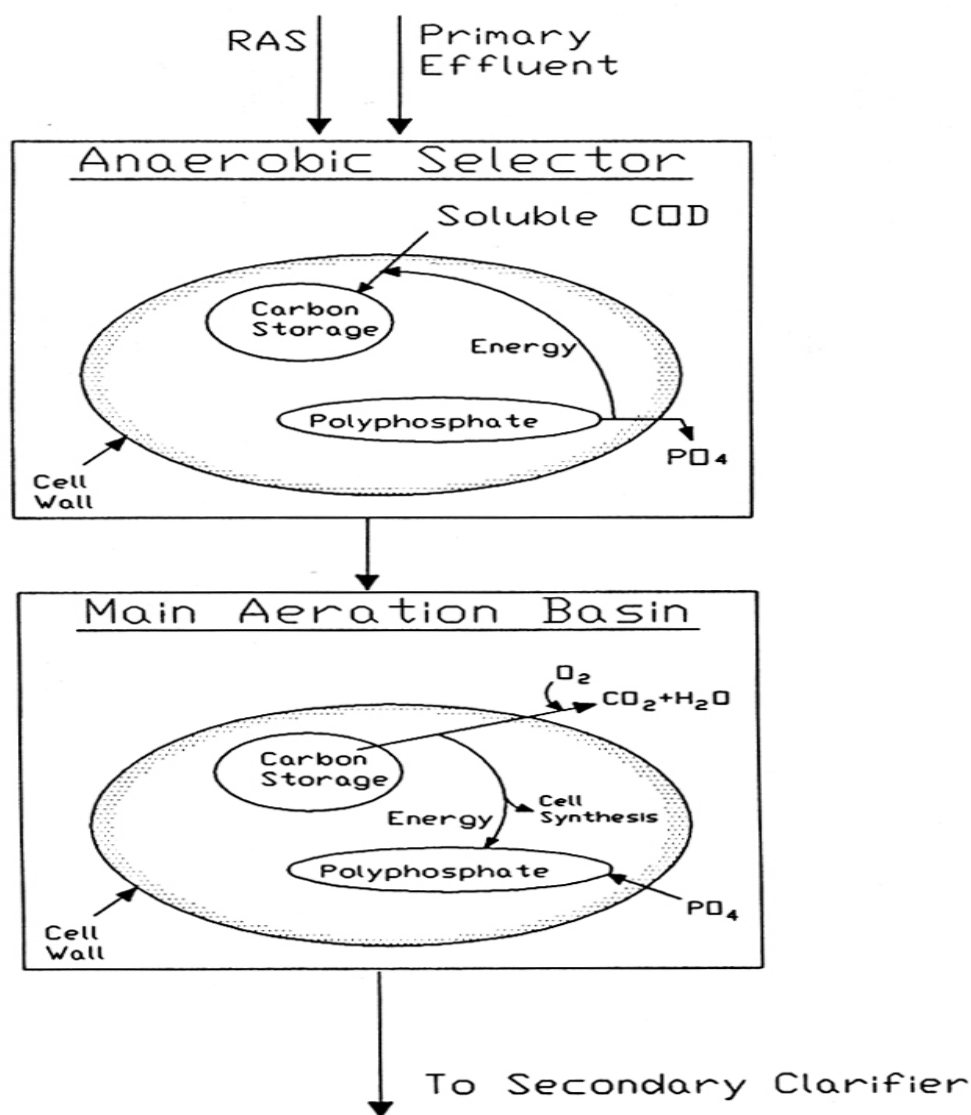

Figure 3.1 Microorganism cell reactions during phosphorus release and luxury uptake processes <sup>1</sup>

## Anaerobic Selector

- Strict anaerobic conditions must be maintained in the anaerobic selector in order to properly condition the microorganisms and induce them to release phosphorus, as phosphate, from their cell mass. Also, sufficient detention time in the anaerobic selector is required to force the microorganisms to have to use the phosphorus in their cell mass for survival. However, if the microorganisms stay too long in the anaerobic selector, they will die. Therefore, the operator must strike the proper balance to achieve the desired treatment without ruining the process.



**Anaerobic** is a condition in which atmospheric or dissolved molecular oxygen is not present in the aquatic environment. <sup>2</sup>

## Aerobic Reactor



Aerobic is a condition in which atmospheric or dissolved molecular oxygen is present in the aquatic environment.<sup>3</sup>

- The aerobic reactor provides an environment rich in food and oxygen. In this environment the microorganisms are able to use the carbon stored in their bodies as an energy source so that they can rebuild their cell structure that was depleted in the anaerobic selector. In doing this, the microorganisms absorb phosphorus from the wastewater. However, as a reaction to having their cell structure depleted, the microorganisms absorb much more phosphorus than they actually need to rebuild their cell structure. This is a key element in the biological phosphorus removal process.

## Equipment Requirements

Process layouts for biological phosphorus removal may utilize sedimentation tanks to remove the cell mass of the microorganisms that contain accumulated phosphorus, or they may include chemical treatment to enhance the removal of dissolved phosphorus. In either case, anaerobic and aerobic treatment tanks are utilized as well as a solids sedimentation tank.

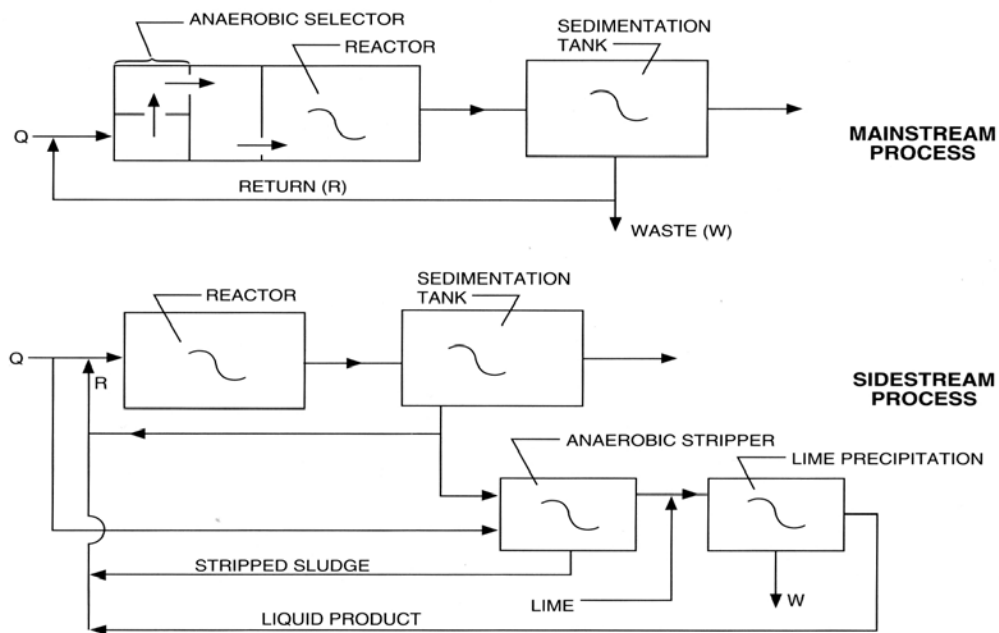

Figure 3.2 Biological Phosphorus Removal Process Layouts<sup>4</sup>

- **Aerobic Reactor**
  - The aerobic reactor is a conventional activated sludge treatment tank that provides the proper environment for luxury uptake of phosphorus.
  - The tank provides a means to aerate the wastewater and mix it completely with the microorganisms in the tank.
  - In the mainstream process, the influent to the aerobic tank is the effluent of the anaerobic tank.
  - In the sidestream process, primary effluent and aerobic and anaerobic sludge streams are discharged into the aerobic tank.
  
- **Sedimentation tank**
  - In both the mainstream and sidestream process schemes, a sedimentation tank is used to remove solids, including microorganisms, from the effluent of the aerobic tank.
  - In both the mainstream and sidestream processes, some of the microorganisms removed are returned to the anaerobic selector. However, in the mainstream process, some solids are wasted, while in the sidestream process some solids are returned to the aerobic reactor.
  - Solids wasting occurs from the chemical clarifier in the sidestream process.
  
- **Anaerobic Selector/Stripper**
  - The anaerobic selector provides an environment low in food and absent oxygen to encourage the microorganisms to release phosphorus from their cell mass.
  - Typically, the anaerobic selector will have baffles to create a series of flow-through chambers and a subsurface mechanical mixer will be used to mix the tank.
  - Diffusers could not be used because oxygen must not be introduced into this tank.
  
- **Chemical Phosphorus Removal System**
  - The sidestream process uses chemicals to enhance the removal of dissolved phosphorus from the anaerobic selector effluent. Details of the equipment are discussed further in Unit 3 – III.

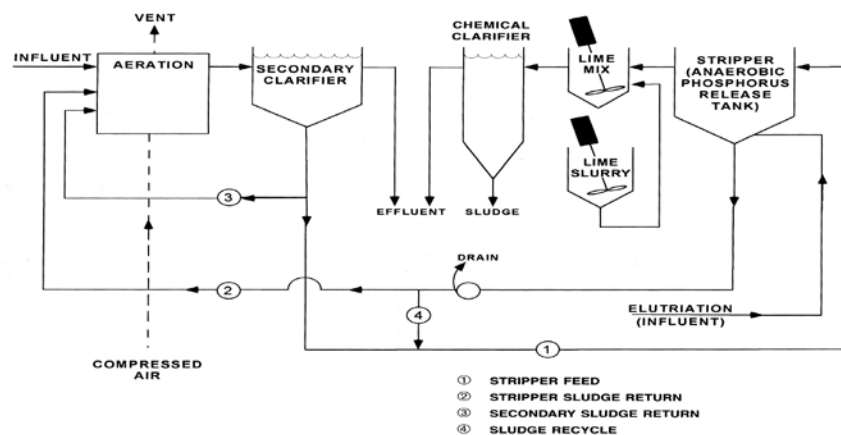

Figure 3.3 Luxury Uptake of Phosphorus (elevation flow diagram) <sup>5</sup>



## Operational Considerations

Operational considerations relate directly to the process employed for phosphorus removal. The more complex sidestream process will have operational considerations above and beyond the mainstream process because of additional issues associated with a chemical treatment system, including chemical feed systems and a chemical clarifier. Key operational considerations for both process types are presented below.

- Anaerobic Selector Cell Residence Time
  - The operator must carefully select and monitor the residence time of the microorganisms in the anaerobic selector to achieve the process goals without damaging the microorganisms.
  - If the residence time is too short, the microorganisms may not need to metabolize the phosphorus in their cell mass. If this happens, phosphorus will not be released and the stimulus for luxury uptake of phosphorus in the aerobic reactor may not be triggered.
  - If the residence time is too long, the microorganisms may not survive their stay in the anaerobic selector.
  
- Maintenance of Anaerobic Conditions in the Anaerobic Selector
  - A strict anaerobic environment is necessary in the anaerobic selector to force the microorganisms to utilize the polyphosphates in their cell mass for energy to survive their stay in the anaerobic selector.
  - If any oxygen is available to help the microorganisms metabolize carbon sources in the anaerobic selector, the microorganisms will not need to use the polyphosphates in their cell mass and the biological phosphorus removal process will fail.
  
- Maintenance of Sufficient Dissolved Oxygen in the Aerobic Reactor
  - The luxury uptake process requires that the environment for the microorganisms provide sufficient oxygen so the microorganisms will have all the resources they need to regenerate their cell mass.
  - In order to regenerate their cell mass, the microorganisms need the oxygen to metabolize the carbon sources they accumulated in the anaerobic selector. The carbon sources provide the energy required by the microorganisms to transform dissolved phosphorus into polyphosphates, which are used to rebuild their cell mass.

- Considerations Associated with the Chemical Phosphorus Removal System
  - There are a number of issues associated with chemical removal of phosphorus that must be addressed to properly operate the system.
    - The chemical make-up and feed systems must be operated to deliver the proper chemical dosage
    - The environment of the chemical treatment tank must be monitored to maintain the proper pH range for precipitation of phosphorus
    - The residence time in the chemical clarifier must be sufficient to properly remove the phosphorus.

## Phosphorus Removal by Lime Precipitation

A common alternative for removal of phosphorus from wastewater is lime precipitation. The process relies on chemical addition and a high pH to precipitate phosphorus from the wastewater. The high reaction pH requires that a neutralization step be incorporated into the treatment system prior to the discharge of effluent. Also, the amount of lime required to achieve satisfactory treatment generally produces a relatively large amount of sludge for disposal. However, the lime sludge does dewater well, making sludge volume reduction easier.

### How the Process Works

- Calcium reacts with phosphate in the presence of hydroxyl ion (high pH) to form an insoluble precipitate, hydroxylapatite. The following equation describes the reaction that occurs:

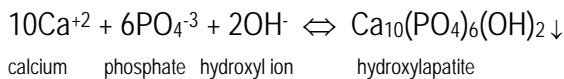

- The amount of lime required for treatment is generally independent of the amount of phosphorus present and depends primarily on the alkalinity of the wastewater.
- Typically, the pH of the wastewater will be raised to the range of 10 to 11 with the addition of lime to properly precipitate the phosphorus present.

### Equipment Requirements

The equipment required for the lime precipitation process includes lime preparation and feeding systems; mixing and flocculation chambers; chemical clarifiers; and associated pumps and piping. In addition, equipment may be required for sludge thickening; neutralization of the treated wastewater prior to discharge; recovery of the lime from the sludge; and sludge management. Key equipment components are briefly described below. Additional details related to chemical feeding systems can be obtained from other sources, including another PADEP training module devoted to chemical feeding systems.

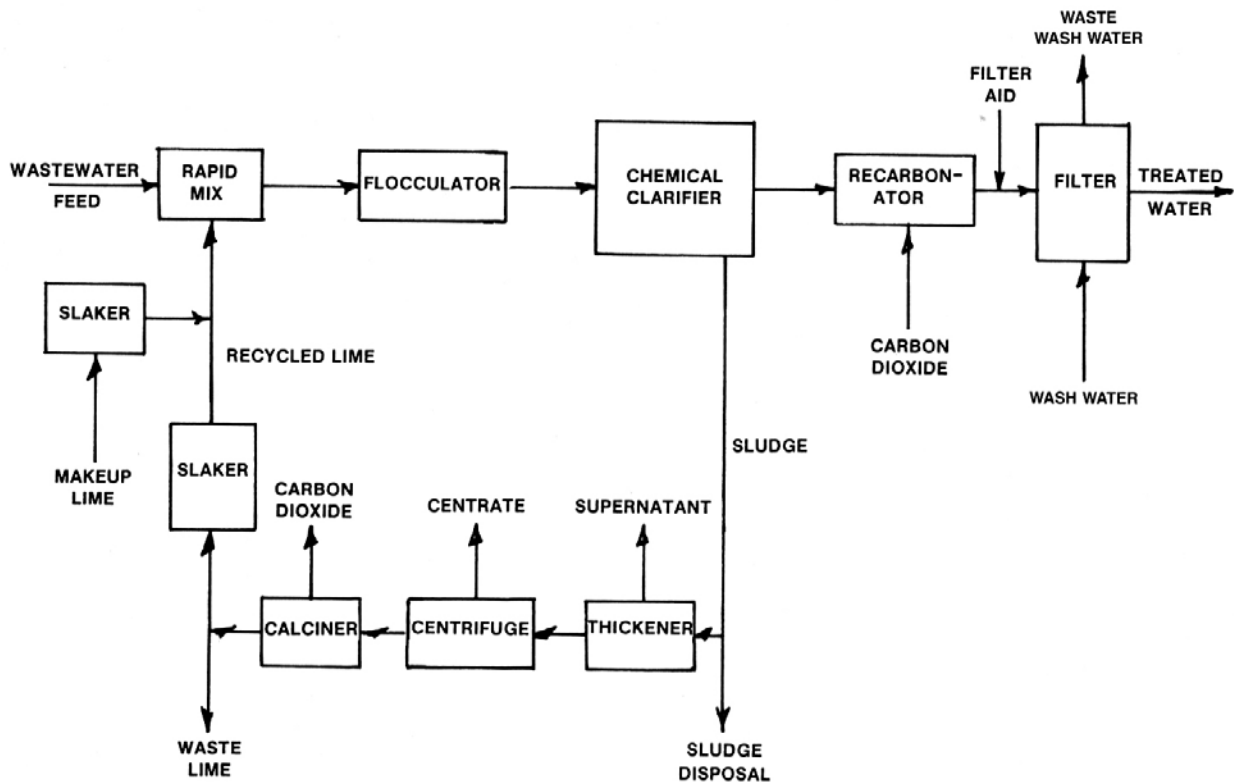

Figure 3.4 Single-stage lime recarbonation process <sup>6</sup>

- Lime Storage and Feeding System
  - Lime usually comes in a dry form (calcium oxide) that must be mixed with water to form a slurry (calcium hydroxide) before use.
  - Typically, calcium oxide will be fed from a storage bin by a dry chemical feeder to a slurry preparation tank, where water is added and the slurry is mixed. The slurry is then metered to the point of application.
  
- Mixing Chamber
  - Wastewater to be treated and the lime slurry are added to a chamber mixed by a high-speed mixer. The purpose is to rapidly and intimately contact the lime with the wastewater. Typically, the mixing chamber will have a detention time of only a few minutes.
  
- Flocculation Chamber
  - The flocculation chamber is an area of controlled, low-intensity mixing that is designed to provide opportunities for collisions between precipitated solids in order to make them agglomerate into larger, more dense particle that will settle readily in a clarifier. Typically, this chamber may have a detention time of 15 minutes.

- Clarifier
  - A clarifier provides a quiescent zone with no mixing so that agglomerated particles will settle out of solution to produce a clear effluent.
- Sludge Dewatering (if necessary)
  - Commonly, a thickening tank will be required to thicken the lime sludge. This may be used in conjunction with another sludge dewatering device, especially if lime is recovered and reused. Otherwise, because lime sludge generally dewateres easily, only a thickening tank may be used.
- Recarbonation Tank
  - The recarbonation tank is where the wastewater pH is adjusted down to a suitable pH range for discharge. This is often accomplished by injecting carbon dioxide into the wastewater, but other means may also be used to bring the pH down to the appropriate discharge range.
- Effluent Polishing System
  - Final removal of solids before discharge of the wastewater should be incorporated into the treatment system. This will generally be necessary because the recarbonation process produces precipitates, notably calcium carbonate. Effluent polishing would normally be accomplished with a filter. Effluent polishing systems were discussed in detail in Unit 2 of this Module.
- Pumps, Piping, and Instrumentation
  - Transfer pumps and piping will be required to interface the various treatment components of the lime precipitation system. Also, instrumentation will be required to monitor chemical addition, flow rates, pH of the treatment tank and the final effluent, and for recording system performance.

### Operational Considerations

There are a number of operational considerations associated with a lime precipitation system because of the range of equipment components involved in the process. The following discussion focuses on a few of the more prominent considerations.

- Target pH Level
  - The target pH range for lime precipitation of phosphorus is 10 to 11. A large fraction of phosphorus can be removed at a pH as low as 9; however to obtain the maximum amount of phosphorus removal, a pH in excess of 11 may be required. However, a disadvantage of using a higher pH is the possibility of solubilizing organic matter in the wastewater, which increases the turbidity and reduces the quality of the effluent. Therefore, the operator should operate the system at the lowest pH that will reliably provide the required phosphorus removal. A lower pH will also reduce the recarbonation requirements prior to discharge.

- Effectiveness of Flocculation
  - Maintaining the optimum mixing environment and the proper use of flocculation aids will produce an effective flocculation system. The goal is to produce large particles and a clear supernatant (liquid phase) to remove the maximum amount of phosphorus without impairing the effluent.
  
- Recarbonation Control
  - Recarbonation of the treated effluent is required to adjust the effluent pH from approximately 10 to 11 down to approximately 7 to 8, or whatever pH is necessary to meet the discharge permit requirements.
  - During recarbonation, as the pH is reduced, calcium carbonate will begin to precipitate from solution and settle. If a single stage recarbonation system is used, the solids load produced will go directly to the effluent polishing filter, which may create short filter runs. If a two-stage recarbonation system is used, the pH is reduced in two stages so that the bulk of the calcium carbonate precipitate can be settled out in a preliminary sedimentation tank prior to the second recarbonation chamber. This design reduces the solids load on the effluent polishing system.
  
- Lime Handling Safety Procedures
  - Lime is a strong caustic solution that can cause severe burns if it comes in contact with the skin, eyes, or mucous membranes. Care should be exercised when working with lime slurries as well as calcium oxide (quicklime), the dry form of lime.

### Phosphorus Removal by Alum Flocculation



**Alum** (aluminum sulfate) is an effective chemical for precipitating phosphorus from wastewater. When added to wastewater containing phosphorus, alum produces aluminum phosphate and aluminum hydroxide precipitates.

#### How the Process Works

When alum is added to wastewater, it reacts with the alkalinity in the wastewater to form aluminum hydroxide precipitate. If phosphates are present, the aluminum ion also reacts with the phosphate to form an aluminum phosphate precipitate. Phosphorus is therefore removed by direct precipitation with aluminum ion and is enhanced by adsorption of phosphorus onto the aluminum hydroxide precipitate.

- The following key reactions occur during alum precipitation of phosphorus from wastewater:

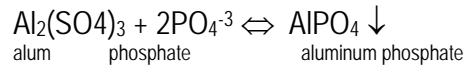

- When alum is mixed with wastewater, it acts as an acid, reducing the pH of the wastewater (by reducing alkalinity). Optimum phosphorus removal is generally achieved at a pH range of approximately 6.0 to 7.0.

### Equipment Requirements

The equipment requirements for alum precipitation are generally similar to the requirements for lime precipitation with a few minor differences as highlighted below.

- Alum Storage and Feeding System
  - Alum is fed to the point of application as a solution, rather than a slurry as lime is. Also, if alum is not procured as a liquid, operators will generally prepare alum solutions in storage tanks or day tanks from dry alum rather than relying on a dry chemical feed system to mix the solution.
  - Because of its chemical nature, alum must be carefully mixed into solution to minimize the possibility of incomplete mixing and reduce the chance that alum will congeal and stick to piping and clog pumps.
- Effluent Treatment
  - Optimum phosphorus removal is generally achieved at a pH range of approximately 6.0 to 7.0. Therefore, unlike lime precipitation, alum precipitation may not require a final pH adjustment system or may only need minor pH adjustment, depending on the discharge permit requirements.
  - Because the floc formed by alum is relatively fragile, polymers are generally used to produce a larger, more robust floc. Effluent polishing by filtration is also common.

### Operational Considerations

The operational considerations for alum precipitation are generally similar to those for lime precipitation with a few minor differences as highlighted below.

- Alum Handling and Safety Precautions
  - A principal concern with using alum is that a very slippery solution is formed when it is mixed with water. Spills of alum solution can produce slipping hazards, so spills should be promptly cleaned.

### ■ Alum Dosage

- Overdosing with alum will have detrimental effects on system performance. Overdosing with alum further reduces the wastewater pH, which hinders the alum's ability to coagulate suspended solids. The result may be a cloudy supernatant containing turbidity and suspended solids. It is preferable to under dose slightly than to overdose.



**Supernatant** is the liquid removed from settled sludge. <sup>7</sup>

- Jar testing is recommended to optimize the alum dosage and to avoid overdosing. Jar testing should be performed routinely to verify that the correct alum dosage is being applied.

### ■ Target pH Level

- Optimum phosphorus removal is generally achieved at a pH range of approximately 6.0 to 7.0. This pH level is achieved naturally by the addition of alum, and does not require the addition of other pH adjusting chemicals.

### ■ Alum Feed System Pump and Pipe Plugging

- The most important maintenance concern for alum feeding systems is the prevention of plugging in the piping and pumps. This becomes a significant problem if alum is not properly and thoroughly mixed into solution, but nevertheless, plugging is a concern for any alum system. By periodically running clear water through the alum feed system, plugging problems can be reduced.

### ■ Effectiveness of Flocculation

- Because the floc formed by alum is relatively fragile, polymers are often used to produce larger and more robust floc particles. The use of polymers and proper control of the mixing intensity in the flocculator are important considerations in achieving good overall system performance.

### ■ Sludge Dewatering and Disposal

- Aluminum hydroxide is a gelatinous solid that is difficult to thicken and dewater. Therefore, polymers are typically used as a flocculant aid to produce a precipitate that is more amenable to thickening and dewatering. Nevertheless, the polymer enhanced aluminum phosphate precipitate will not thicken or dewater as well as lime precipitated phosphorus. There are no economical methods currently available to recover alum, so the sludge is disposed of.





### Key Points for Unit 3 – Phosphorous Removal

- Phosphorus is an essential nutrient for algae growth. Algae causes taste and odor problems, is aesthetically unpleasing and most importantly, creates enormous oxygen demand when algal bloom dies off.
- The most common methods for removing phosphorus from wastewater are biological removal and chemical precipitation.
- An effective biological phosphorus removal system can be created by transferring the microorganisms back and forth between controlled environments that first forces them to release phosphorus from their cells and then induces them to absorb more phosphorus than they normally would.
- Luxury uptake of phosphorus occurs when the microorganisms from the anaerobic tank are transferred to an aerobic tank with plenty of food.
- The luxury uptake process requires that the environment for the microorganisms provide sufficient oxygen so the microorganisms will have all the resources they need to regenerate their cell mass.
- A common alternative for removal of phosphorus from wastewater is lime precipitation. The process relies on chemical addition and a high pH to precipitate phosphorus from the wastewater.
- Lime usually comes in a dry form (calcium oxide) that must be mixed with water to form a slurry (calcium hydroxide) before use.
- Lime is a strong caustic solution that can cause severe burns if it comes in contact with the skin, eyes, or mucous membranes. Care should be exercised when working with lime slurries as well as calcium oxide (quicklime), the dry form of lime.
- Alum (aluminum sulfate) is an effective chemical for precipitating phosphorus from wastewater.
- A principal concern with using alum is that a very slippery solution is formed when it is mixed with water. Spills of alum solution can produce slipping hazards, so spills should be promptly cleaned.

**Exercise for Unit 3 – Phosphorous Removal**

1. How would you determine the optimum alum dosage for phosphorus removal?
  
2. What would you do first if you observed a cloudy appearance in the effluent from a filtration unit in a phosphorus removal system that uses alum?
  
3. What safety hazard might operators encounter in areas where aluminum sulfate is mixed with water?
  
4. Two chemical processes are commonly used to remove phosphorus from wastewater are \_\_\_\_\_ precipitation and \_\_\_\_\_ flocculation and precipitation.
  
5. A polymer is often used as a flocculation aid with alum, because the aluminum phosphate precipitate is not dense enough to provide adequate removal.
  - a. \_\_\_\_ True
  - b. \_\_\_\_ False
  
6. Luxury uptake is a term used to describe a reaction of microorganisms after they have been depleted of \_\_\_\_\_.
  
7. Aerobic is a condition in which atmospheric or dissolved molecular \_\_\_\_\_ is present in the aquatic environment.
  
8. A strict anaerobic environment is necessary in the anaerobic selector to force the microorganisms to utilize the polyphosphates in their cell mass for energy to survive their stay in the anaerobic selector.
  - a. \_\_\_\_ True
  - b. \_\_\_\_ False
  
9. Typically, the pH of the wastewater will be raised to the range of \_\_\_\_ to \_\_\_\_ with the addition of lime to properly precipitate the phosphorus present.
  
10. When alum is mixed with wastewater, it acts as an acid, reducing the pH of the wastewater (by reducing alkalinity). Optimum phosphorus removal is generally achieved at a pH range of approximately \_\_\_\_ to \_\_\_\_.
  
11. \_\_\_\_\_ testing is recommended to optimize the alum dosage and to avoid overdosing.

<sup>1</sup> John G. M. Gonzales, "Chapter 5: Phosphorus Removal," in *Advance Waste Treatment*, (Sacramento, CA: California State University, Sacramento Foundation, 1998), p.455.

<sup>2</sup> Gonzales, p.447.

<sup>3</sup> Gonzales, p. 447.

<sup>4</sup> Gonzales, p. 453.

<sup>5</sup> Gonzales, p. 456.

<sup>6</sup> Gonzales, p. 470.

<sup>7</sup> Ross Gudgel and Larry Peterson, "Chapter 2: Activated Sludge," in *Advance Waste Treatment*, (Sacramento, CA: California State University, Sacramento Foundation, 1998), p. 52.

(This page was intentionally left blank.)

---

---

# Unit 4 – Nitrogen Removal

---

---

## Learning Objectives

- Identify three distinct technology options for removing nitrogen from wastewater.
- Explain the purpose and process of Nitrification.
- Explain the purpose and process of Denitrification.
- Explain the difference between suspended and attached growth reactors.
- Describe each of the following processes, list the equipment required for each process and identify the operational considerations for each:
  - Ammonia Stripping
  - Breakpoint Chlorination

**Why Remove Nitrogen from Wastewater**

Nitrogen is a nutrient in the algal food chain, and in the presence of phosphorus, is responsible for stimulating algal blooms in receiving streams. When these algal blooms die, they create a significant oxygen demand that can deplete the stream of oxygen and cause fish kills. Removal of nitrogen at the wastewater treatment plant, before effluent is discharged to the receiving stream, can protect the streams from unsightly and troublesome algal blooms. In addition, ammonia in the wastewater discharge is toxic to aquatic life, it creates additional chlorine demand during disinfection, and it creates additional oxygen demand in the receiving streams.

**Technology Options for Nitrogen Removal**

Nitrogen removal from wastewater can be accomplished by a variety of biological, physical and chemical processes. Some of these processes are introduced below and listed in Table 4.1.

<b>System</b>	<b>Operational Considerations</b>
<b>1. PHYSICAL TREATMENT METHODS</b> A. Sedimentation B. Gas Stripping	1. Expensive
<b>2. CHEMICAL TREATMENT METHODS</b> A. Breakpoint Chlorination B. Ion Exchange	2. Expensive
<b>3. BIOLOGICAL TREATMENT METHODS</b> A. Activated Sludge Processes B. Trickling Filter Processes C. Rotating Biological Contactor Processes D. Oxidation Pond Processes E. Land Treatment Processes (Overland Flow) F. Wetland Treatment Systems (Hyacinth Cultures)	3. A-D Operational control. Additional costs for oxygen to produce nitrification.  3. E & F Land requirements. Suitable temperatures. Control of plants.

Table 4.1 Types of Nitrogen Removal Systems <sup>1</sup>

### Biological Processes

- The most common method of biological nitrogen removal is nitrification/denitrification. This is accomplished by modifying the activated sludge process to encourage the growth of nitrifying microorganisms in one part of the process and denitrifying organisms in another part of the process.
- Nitrogen removal can also be achieved using attached growth reactors such as trickling filters and rotating biological contactors (RBCs).

### Physical Processes

- The most common method of physically removing nitrogen from wastewater is ammonia stripping. In this process, ammonia gas is removed from the wastewater by chemically altering the chemical equilibrium to convert nitrogen to ammonia gas, then blowing air through the wastewater stream to strip the ammonia gas from the wastewater.

### Chemical Processes

- The most common method of removing nitrogen from wastewater is breakpoint chlorination. In this process, ammonia nitrogen is converted to nitrogen gas by chemically treating the wastewater with excess chlorine. Because of the large amount of chlorine required to oxidize the ammonia to nitrogen gas, this process is generally too expensive to operate except as a polishing step following another nitrogen removal method.

## Nitrification/Denitrification Process

Nitrification/denitrification is a biological process for removing nitrogen from wastewater. The environment established, and the types of microorganisms predominating to achieve nitrification are different from those used to denitrify. Also, note that it is also possible to nitrify the wastewater by converting ammonia to nitrates without going to the next step of denitrifying, which converts nitrates to nitrogen gas.

### Goal of the Process

The overall goal of nitrification/denitrification is to remove nitrogen compounds, especially ammonia, from wastewater. This is accomplished by converting ammonia nitrogen to nitrates and subsequently converting nitrates to nitrogen gas, which leaves the wastewater and enters the atmosphere.

### Chemical Conversions during Nitrification

There are actually two reactions and two distinct autotrophic microorganisms responsible for nitrification.



**Autotrophic** microorganisms are those that break down inorganic matter to obtain energy and food for survival.

- These reactions occur simultaneously in the same environment with the overall result being the conversion of ammonia to nitrates ( $\text{NO}_3^-$ ). In the first step, ammonia (in the form of ammonium ion) is converted to nitrites ( $\text{NO}_2^-$ ) by a microorganism known as Nitrosomonas. Nitrosomonas uses dissolved molecular oxygen to convert the ammonium ion to nitrite in accordance with the following equation:

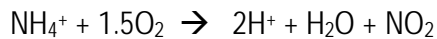

- The second step is the conversion of nitrites to nitrates ( $\text{NO}_3^-$ ) by a microorganism known as Nitrobacter. Nitrobacter requires free oxygen (dissolved), a carbon source, and the correct environment (pH and temperature) to complete the transformation. The following equation presents the reaction that occurs to produce nitrates:

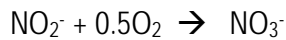



### Chemical Conversions during Denitrification

The denitrification process is actually accomplished by a number of heterotrophic microorganisms that break down nitrates to obtain the oxygen they need for survival.



**Heterotrophic** microorganisms are those that break down organic matter to obtain energy and food for survival.

- The heterotrophic microorganisms require a carbon source to complete the metabolism (break down) of nitrates into nitrogen gas (and other minor end products). Typically, methanol, which is added to the process tank by the operator, is used as a carbon source (food). Oxygen to metabolize the food is obtained from nitrates rather than dissolved oxygen. The following equation represents the reaction that occurs to reduce nitrates to nitrogen gas using methanol as a carbon source:

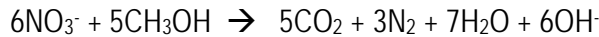

### Nitrification Reactors

Nitrification can be made to occur in suspended and attached growth reactors. A suspended growth reactor is typically an aeration tank, which contains microorganisms mixed with the wastewater. An attached growth reactor has a specific location where the microorganisms grow and the process occurs when wastewater is passed over the attached growth.

#### Suspended Growth Reactors

- The environment of a suspended growth reactor (aeration tank) must be controlled to provide conditions that will encourage the growth and activity of the nitrifying microorganisms.
- Modifications of the conventional activated sludge process can be used to encourage nitrification, but because of the limiting conditions necessary to encourage the growth of nitrifying microorganisms, only a few of the modifications allow for significant nitrification.

#### *Process Modes Suitable for Nitrification*

- A conventional plug flow activated sludge tank may be operated to encourage nitrification. Because of the detention time normally maintained for this type of plant, nitrification can occur if the other necessary environmental conditions are satisfied.

### *Factors Impacting Performance*

One of the most important factors necessary to achieve nitrification is a sufficient sludge age. Sludge age is a measure of how long the mixed liquor suspended solids (MLSS) is maintained in the aeration process before being wasted. Because the nitrifying microorganisms are slow growing compared to other microorganisms in the MLSS, the sludge age must be on the order of 10 days or greater to develop a population of nitrifying microorganisms that is large enough to achieve substantial nitrification. In addition, the appropriate pH, temperature, dissolved oxygen concentration, and detention time is important parameters for optimizing the nitrification of wastewater. Because the nitrification reaction produces hydrogen ion (H<sup>+</sup>), which reacts to reduce alkalinity, the pH of a nitrifying reactor may decrease over time as the buffering capacity (alkalinity) of the wastewater is reduced. This must be properly monitored and controlled by the operator.

### **Attached Growth Reactors**

Attached growth reactors, such as trickling filters, can nitrify wastewater if sufficient nitrifying microorganisms are encouraged to grow in the reactor. In order for this to happen the environmental conditions must be right to encourage the growth of nitrifying microorganisms rather than non-nitrifying microorganisms.

### *Commonly Used Process Modes*

Trickling filters, packed towers, and rotating biological contactors (RBCs) are commonly used attached growth reactors for nitrification. For trickling filters and packed towers, air may be introduced by either natural or forced ventilation. Forced ventilation, where air is provided by fans or blowers, would provide a more reliable source of ventilation. RBCs utilize rotating discs upon which the microorganisms grow. The process works by rotating the discs alternately through the wastewater and the air. If additional oxygenation is required, the wastewater may be aerated in the immediate vicinity of the RBCs.

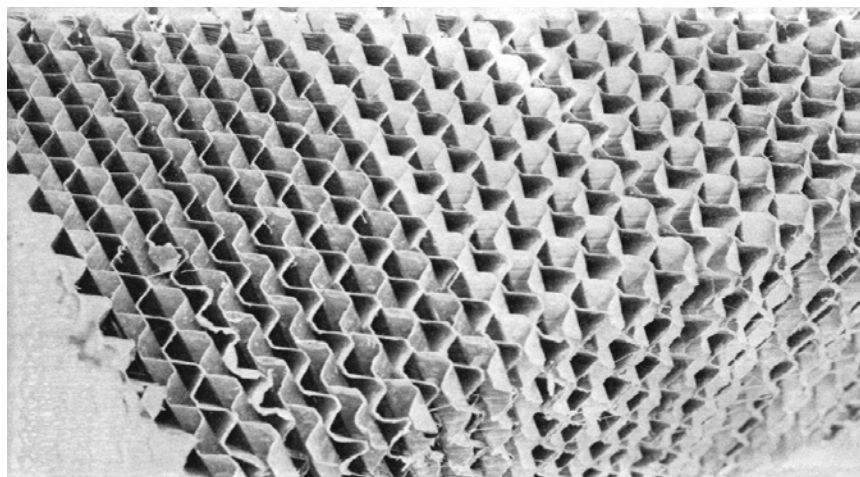

Figure 4.1 Trickling Filter Plastic Media <sup>2</sup>

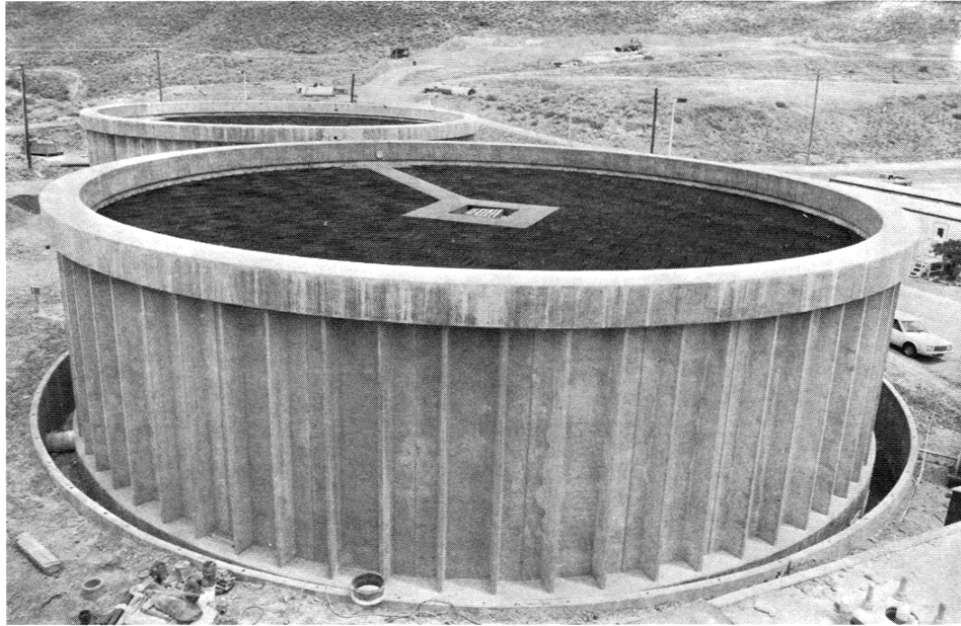

Figure 4.2 Packed Tower for Nitrification <sup>3</sup>

### *Factors Impacting Performance*

Aerobic conditions are essential for successful nitrification. Also, sufficient time must be provided for the nitrifying microorganisms to convert ammonia to nitrates. This can be managed by controlling the hydraulic loading rate to the reactor and by managing the return sludge rate to the reactor.

## **Denitrification Reactors**

Denitrification can be made to occur in suspended and attached growth reactors. A suspended growth reactor is typically a mixed anaerobic tank, which contains microorganisms mixed with the wastewater containing no dissolved oxygen. An attached growth reactor has a specific location where the microorganisms grow and the process occurs when wastewater is passed over the attached growth. Anoxic conditions (no dissolved oxygen) are required for attached growth reactors too.

### **Suspended Growth Reactor**

A suspended growth denitrification reactor is typically a tank, similar to an aeration tank, but without the application of oxygen or air. Mixing would be provided by a submerged mechanical mixer or a turbine-type mixer. A portion of an existing aeration tank or a separate chamber may be used, as long as the appropriate environmental conditions are established to optimize denitrification.

### *Factors Impacting Performance*

Denitrification requires anaerobic conditions and a source of food (carbon source). The denitrifying microorganisms obtain oxygen from chemically bound oxygen in nitrate molecules. The presence of dissolved oxygen will allow other competing microorganisms to grow and possibly thrive, which would inhibit denitrification.

### **Attached Growth Reactor**

Attached growth reactors for denitrification generally use a submerged media upon which microorganisms grow, with wastewater surrounding the media in the void spaces. A fluidized bed may also be used. A fluidized bed is an upflow reactor with a media bed that expands when the wastewater is passed through it at the design velocity. In its operating condition, the media “floats” in the wastewater.

### *Factors Impacting Performance*

Anaerobic conditions are necessary for denitrification to occur. Because the heterotrophic microorganisms responsible for denitrification are slow-growing, the ideal environment is required to preclude the growth of competing microorganisms. If oxygen is present even in a small amount, the competing microorganisms could grow and overwhelm the heterotrophic microorganisms needed for denitrification. A carbon source (food) is also required. Typically methanol is added to provide the food source.

**Process Configurations Based on Sludge Management Options**

Suspended growth denitrification can be performed with various process configurations, based on the order of the operations and how the sludge is managed.

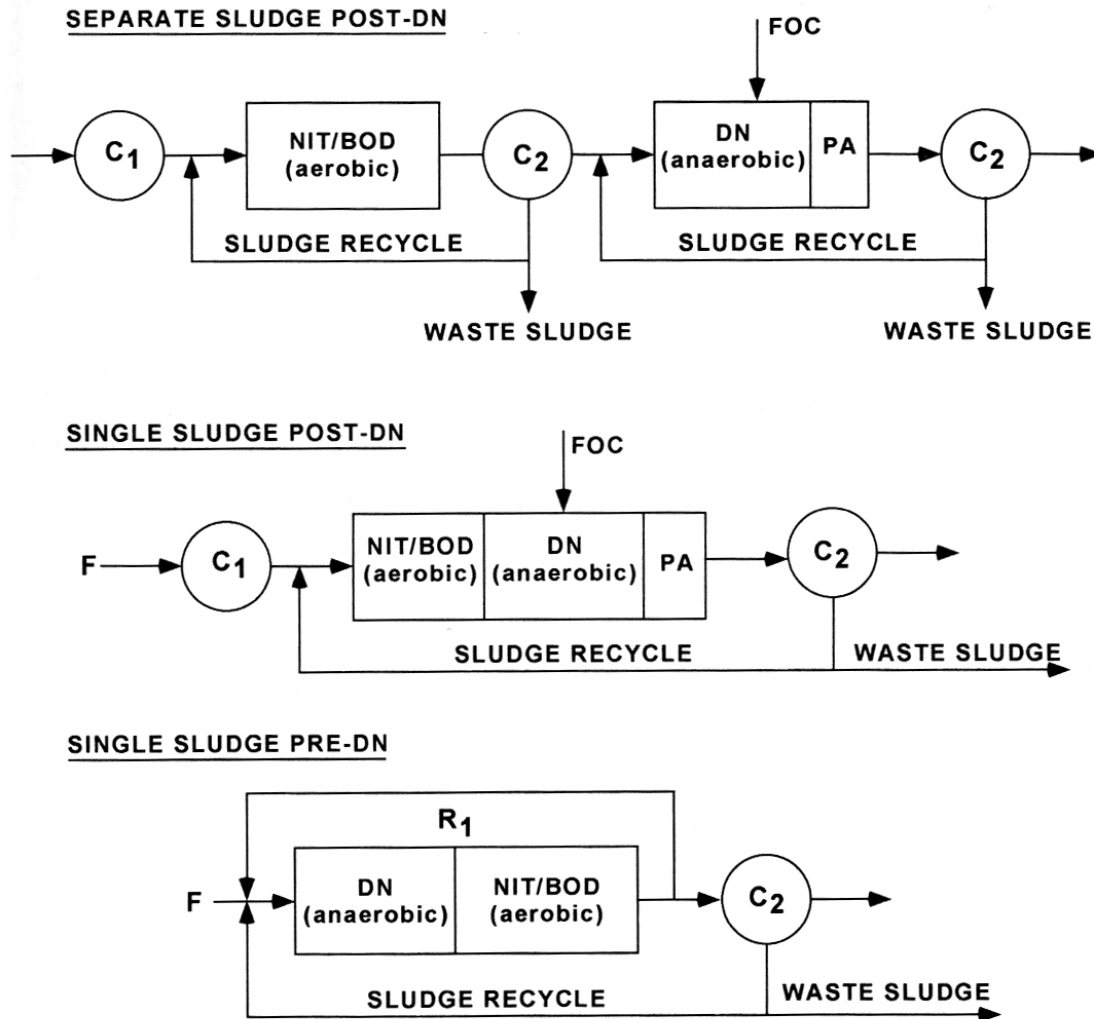

**Legend**

- |                |                               |                |                |
|----------------|-------------------------------|----------------|----------------|
| C <sub>1</sub> | Clarifier 1 or Primary        | PA             | Post Aeration  |
| C <sub>2</sub> | Clarifier 2 or Secondary      | F              | Food Source    |
| C <sub>3</sub> | Clarifier 3                   | R <sub>1</sub> | Recirculation  |
| DN             | Denitrification               | OC             | Organic Carbon |
| NIT/BOD        | Nitrification and BOD Removal |                |                |

Figure 4.3 Nitrification and Denitrification using suspended growth reactors <sup>4</sup>

## Review of Biological Nitrogen Control Reactions

Knowledge of the chemical reactions involved in the nitrification and denitrification processes can be used to develop rules of thumb for controlling and monitoring the processes.

Table 4.2 Summary of Biological Nitrogen Control Reactions<sup>5</sup>

---

### **BIOLOGICAL NITROGEN CONTROL REACTIONS<sup>a</sup>**

---

#### ***Biochemical Nitrogen Removal by Microorganisms (microbial uptake)***

- 0.075 to 0.10 mg N removed per mg net volatile suspended solids produced by microorganisms

#### ***Biochemical Nitrogen Oxidation (Nitrification)***

- 4.6 mg oxygen required per mg nitrogen oxidized
- 7.1 mg CaCO<sub>3</sub> alkalinity depleted per mg nitrogen oxidized
- approximately 0.1 mg net volatile suspended solids formed per mg nitrogen oxidized

#### ***Biochemical Oxidized Nitrogen Removal (Denitrification)***

- 2.9 mg oxygen released per mg oxidized nitrogen removed
- 1.5 mg COD per mg methanol (CH<sub>3</sub>OH)
  - ... 1.9 mg methanol required per mg oxidized nitrogen removed
  - ... 0.7 mg methanol required per mg dissolved oxygen removed

*NOTE:* Sufficient substrate (COD) must be added to satisfy nitrogen reduction and microorganism needs; typically add 1.5 times theoretical predictions.<sup>b</sup>

- 3.6 mg CaCO<sub>3</sub> alkalinity recovered (added to system) per mg oxidized nitrogen removed
- Same to slightly lower net volatile suspended solids per COD (or BOD<sub>5</sub>) removed

*NOTE:* COD removed is the total amount of COD oxidized by microorganisms.

#### ***Chlorine Demand due to Nitrite Nitrogen (associated with incomplete nitrification or denitrification)***

- 2.5 mg chlorine per mg nitrite nitrogen, yielding nitrate nitrogen

---

<sup>a</sup> Prepared by Mike Mulbarger, Paladin Enterprises, Xenia, OH

<sup>b</sup> Theoretical prediction. The quantity calculated on the basis of the theoretical amounts involved in chemical reactions.

---



**Exercise**

1. Nitrification can be accomplished by the use of what two types of biological growth reactors? <sup>6</sup>

---

---

---

---

2. What can an operator do to maintain sufficient alkalinity in a nitrification process? <sup>7</sup>

---

---

---

---

3. What tests must be conducted to monitor nitrogen levels in the reactors during the nitrification process? <sup>8</sup>

---

---

---

---

### How Ammonia Stripping Works

Nitrogen is removed from wastewater in the ammonia stripping process by the forced removal of ammonia gas from the wastewater. In order for this process to be effective, the nitrogen present in the wastewater as ammonium ion ( $\text{NH}_4^+$ ) must be converted to ammonia gas ( $\text{NH}_3$ ). Then, because of the higher concentration of ammonia gas present in the wastewater after the conversion, ammonia gas will begin to release from the wastewater. The release of ammonia gas is enhanced in a stripping tank packed with inert media. As wastewater flows over the media the surface area exposure of the wastewater increases, enhancing the release of ammonia gas. Then the ammonia gas can be removed from the stripper by blowing a large volume of air through the media in the stripping tank. Ammonia is either discharged to atmosphere, if the mass of ammonia is small, or the effluent air stream is treated to remove the ammonia gas before the air is released to atmosphere.

### Equilibrium Equation

- The key to stripping ammonia is converting ammonium ion to ammonia gas as shown in the following equation:

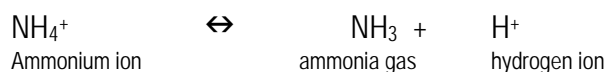

- Note that this reaction can go in both directions: ammonium ion can be converted to ammonia gas, and ammonia gas can be converted to ammonium ion, depending on the environmental conditions.
- At ambient temperatures and a neutral pH of 7, the reaction is shifted almost completely to the left. Therefore, the nitrogen present is almost entirely ammonium ion with very little ammonia gas. As the pH is increased, the reaction begins to shift to the right, so that some of the ammonium ion is converted to ammonia gas.



## Process Considerations

As noted above, the equilibrium equation is sensitive to pH, so that the amount of ammonia gas present changes as the pH changes. However, temperature also affects the equilibrium equation. Refer to the following figure and the discussion that follows:

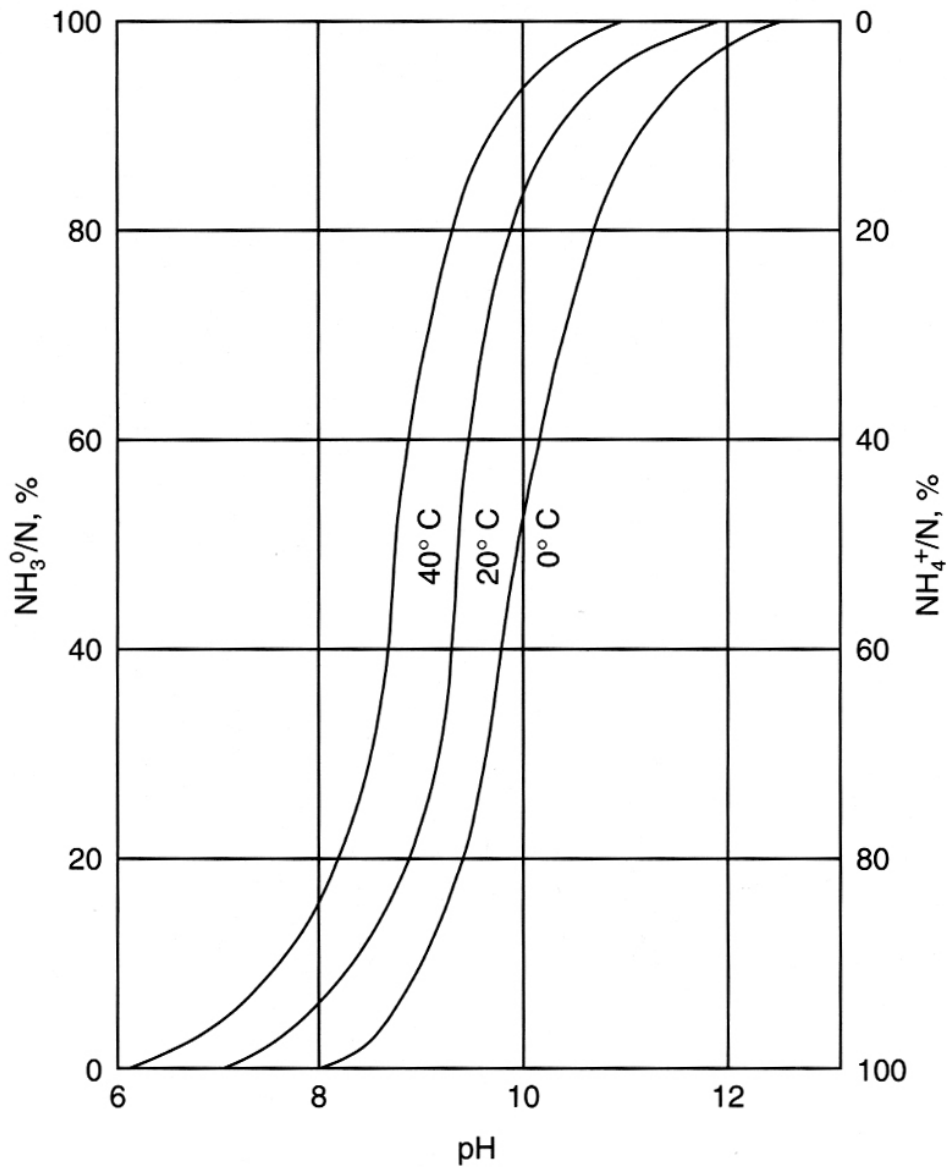

Figure 4.4 Effects of pH and temperature on equilibrium between ammonium ion and ammonia gas <sup>9</sup>

## PHYSICAL NITROGEN REMOVAL BY AMMONIA STRIPPING

---



**Exercise:** Using the figure above answer the following three problems. Your instructor may select additional operating points on the above figure and ask you to answer questions about them.

1. At a temperature of 0°C and a pH of 11.0, what are the approximate percentages of ammonia gas and ammonium ion in solution?
2. At a pH of 9.0 and a temperature of 20°C, what are the approximate percentages of ammonia gas and ammonium ion in solution?
3. If the wastewater contains 60% ammonia gas and 40% ammonium ion, and the temperature of the wastewater is 40°C, what would be the approximate pH of the wastewater?

### pH Sensitivity

- As pH increases, the amount of ammonia gas increases and the amount of ammonium ion decreases. In the figure, note that pH is presented on the bottom, horizontal axis.
- Note that as the pH increases (move from left to right on the bottom axis following one of the curves) the curves move sharply upward. This reflects the change in the ratio of ammonia gas to ammonium ion.
- At any point of a curve, get the percentage of ammonia gas present in the wastewater by reading the value on the left vertical axis. (The value of ammonium ion is read from the right vertical axis.)
  - ▶ For example, at a temperature of 20°C, and pH of 8, less than 10% of the nitrogen will be ammonia gas while more than 90% will be ammonium ion. However, at the same 20°C temperature and a pH of 10, approximately 85% of the nitrogen will be ammonia gas and only 15% will be ammonium ion.

### Temperature Sensitivity

- Note also that the equilibrium is sensitive to temperature.
- As the temperature increases for any given pH value, the ratio of ammonia gas to ammonium ion increases. This means that at higher temperatures, the conversion of ammonium ion to ammonia gas increases.
  - ▶ For example, at a pH of 10 and a temperature of 0°C, approximately 50% of the nitrogen will be present as ammonia gas and 50% will be ammonium ion. However, at pH 10 and a temperature of 40°C, more than 90% of the nitrogen will be ammonia gas and less than 10% will be ammonium ion.

### Ammonia Stripping Equipment

A schematic of an ammonia stripping process with the recovery of lime is shown in the following figure.

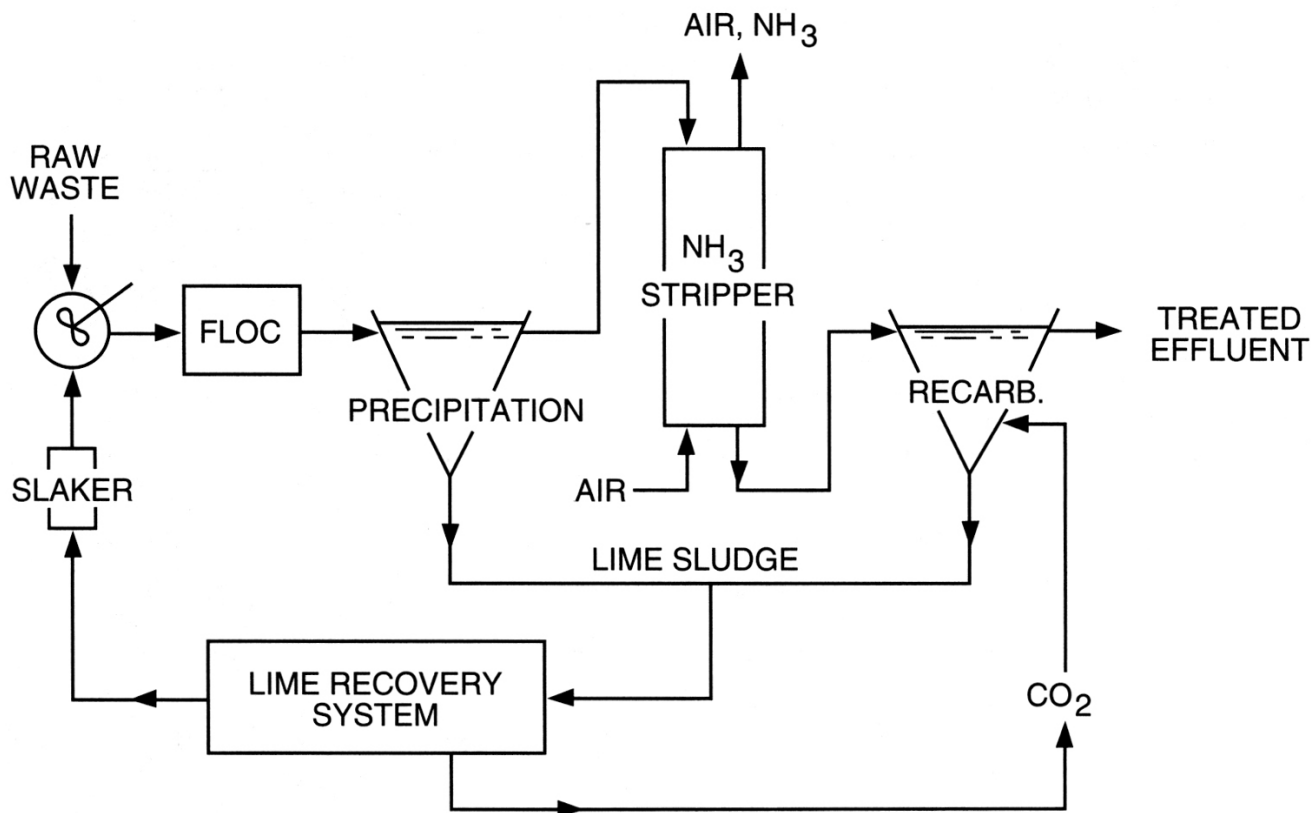

Figure 4.5 Schematic of ammonia stripping process with lime recovery <sup>10</sup>

The focus of the discussion that follows will be on the key components of the ammonia stripper rather than the lime feed and recovery system.

#### ➤ Packed Towers

- ▶ The most common configuration of a stripper is a vertical tank, with inlet and outlet zones, and the middle packed with porous media. The wastewater flows down from the top of the stripper over the media to expose a large surface area of the wastewater making it easier for ammonia gas to leave the wastewater. Air is blown up through the media from the bottom of the stripper.
- ▶ Most modern media is made of plastic in a variety of configurations designed to maximize the wastewater surface area exposed to the atmosphere. Media is most often packed loose, by dumping the media into the stripper, but some media is pre-packed to facilitate removal and replacement.

- Pumps and Piping
  - ▶ Because strippers are generally tall, pumps and piping are required to transport the wastewater to the top of the stripper. Generally, an equalization sump is required to allow the pump to run at a constant, preset rate.
  
- Instrumentation and Controls
  - ▶ Instrumentation and controls are required to monitor performance and adjust the operation based on performance. Level controls would be used in an equalization sump to stop and start the transfer pump that moves the wastewater to the top of the stripper. pH controls are needed on the influent to ensure that the proper treatment pH is attained and on the effluent to ensure that the pH is properly adjusted downward prior to discharge. Air flow monitoring may be used to monitor and adjust the air flow from the blowers.

### Operational Considerations

The ammonia removal efficiency is dependent on several considerations in addition to pH and temperature. Key considerations are discussed below.

- Air to Liquid Mass Flow Ratio
  - ▶ Ammonia removal efficiency depends on the proper ratio of air flow to liquid flow through the stripper.
  - ▶ Stripper design considers this ratio. A rule of thumb for hydraulic loading is to maintain a liquid flow rate of less than 2 gallons per minute per square foot of stripper area (cross sectional area).
  - ▶ The optimum air flow rate is then selected based on the hydraulic loading. Too little air will not remove ammonia gas quickly enough and efficiency will decrease. Too much air and the hydraulic flow through the stripper will decrease, adversely impacting efficiency.
  
- Scaling
  - ▶ Scaling is an inherent operating problem for ammonia strippers. Scale is formed when carbon dioxide from the atmosphere reacts with calcium oxide (lime) to form calcium carbonate. The build up of scale reduces the hydraulic capacity of the stripper and may also impact the capacity of piping and the performance of pumps.
  - ▶ Periodic cleaning of the media, stripper walls, piping, and pumps are recommended to manage scale buildup. A mild acid solution, such as muriatic acid or dilute sulfuric acid, or in some cases hot water, is generally effective in cleaning the stripper.



### Freezing

- ▶ Because of the large size of strippers (height) they are generally installed outside. Therefore, strippers are often subject to the daily and seasonal fluctuations in temperature.
- ▶ The temperature of the wastewater and the temperature of the air will also impact stripper performance.
- ▶ Because temperature impacts performance (refer to discussion above), careful monitoring of system performance over variable temperature ranges is required. In northern climates, in particular, freezing could prevent the operation of strippers. Often strippers in northern climates are insulated to reduce heat loss, prevent freezing, and improve performance.



### Exercise

1. Why must the pH of the wastewater be increased to successfully strip ammonia from wastewater?
2. What are the two most common operating problems for ammonia strippers?
3. How is scale (calcium carbonate) formed during the stripping process?

## How Breakpoint Chlorination Works

When chlorine is added to wastewater containing ammonia, the ammonia reacts with the chlorine (HOCl) to form chloramines.



**Chloramines** are a residual form of chlorine with some disinfecting power.

However, the formation of chloramines depends on several characteristics of the wastewater, such as pH, temperature, and the presence of reducing agents. Before reacting with ammonia, chlorine will react with inorganic reducing materials in the wastewater, such as hydrogen sulfide, nitrite, and ferrous iron. Chlorine also reacts with (oxidizes) organic compounds in the wastewater to form chlororganic compounds. After enough chlorine is added to the wastewater to react with all the inorganic reducing materials, the ammonia, and the organic compounds, then the addition of more chlorine will result in the oxidation of the chloramines and the chlororganic compounds. As each chloramine molecule is completely oxidized, nitrogen gas (N<sub>2</sub>) and nitrous oxide gas (N<sub>2</sub>O) are formed.

Therefore, by adding enough chlorine to wastewater containing ammonia, the ammonia can be completely oxidized. After that, the addition of more chlorine will result in the buildup of free residual chlorine.

### Chemical Reactions

- Three chloramines are formed successively from the reaction of HOCl and NH<sub>3</sub> as shown in the following three equations:

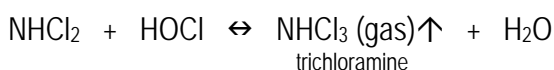
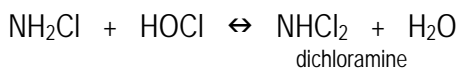
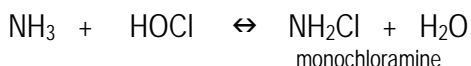

- In addition, chlorine and ammonia can also react stoichiometrically as represented in the following equation:

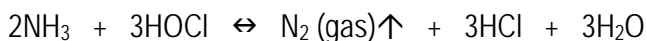

- The extent of these reactions depends on a variety of wastewater characteristics, including pH, temperature, time of contact, and concentrations of the reactants.

## CHEMICAL NITROGEN REMOVAL BY BREAKPOINT CHLORINATION

### Chlorine Demand

As discussed above, chlorine is an oxidizing agent that will react with reducing agents present in the wastewater. It is not possible to directly measure the amount of chlorine that will be required to react with the reducing agents and other compounds that will react with chlorine added to the wastewater. Therefore, chlorine demand is often defined as the difference between the amount of chlorine added to wastewater and the amount of free available chlorine remaining at the end of a specified contact period.

### Breakpoint Chlorination Curve

The breakpoint chlorination curve provides a visual representation of the concentration of chlorine residual present in wastewater at various doses of chlorine. The beginning point of the curve is at the point that the inorganic demand has been satisfied, or alternatively the curve, as presented, assumes that there is no inorganic demand. The following figure is referred to as a breakpoint chlorination curve.

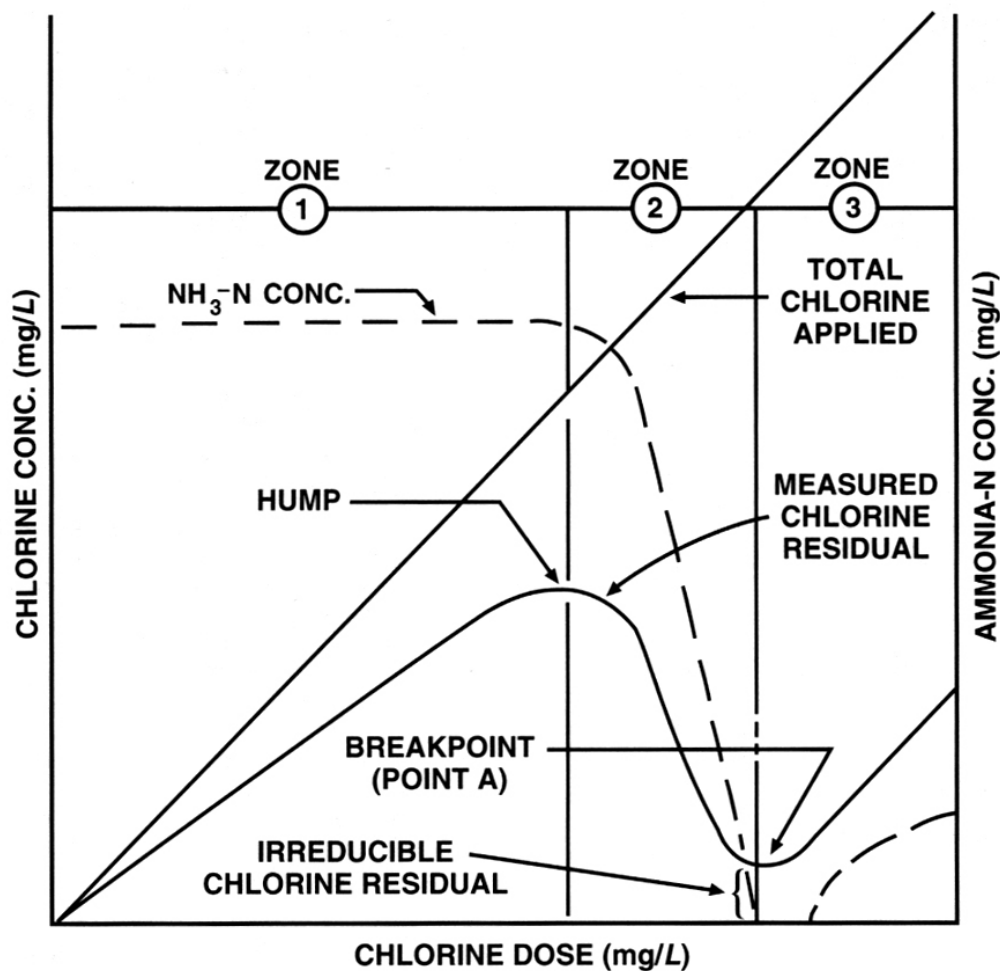

Figure 4.6 Typical breakpoint chlorination reaction curve illustrating destruction of the ammonia molecule <sup>11</sup>



## Equipment Considerations

The amount of chlorine required to achieve the breakpoint depends on the quality of the effluent being chlorinated. Therefore, the equipment capacity required depends on the quality of the effluent and the volume and flow rate of the effluent. Some key equipment considerations are provided below.

### Capacity of Chlorine Feed System

- The required chlorine dosage will depend on the initial inorganic demand, the organic demand, and the concentration of ammonia in the wastewater.
- The required amount of chlorine can be estimated from the overall reactions of chlorine with ammonia, plus the inorganic and organic demands. Approximately 10 milligrams per liter of chlorine will be required for each one milligram per liter of ammonia, plus the inorganic and organic demand.
- The capacity of the system should be sized to at least meet that demand for a maximum daily flow rate.

### Mixing and Reactor Configuration

- A typical configuration includes a rapid mixing tank followed by a contact chamber that provides sufficient detention time for the reactions to go to completion. A serpentine detention chamber is appropriate because it provides opportunities for intermixing of the wastewater as it passes through the chamber.

## Operational Considerations

A summary of the key operational considerations for breakpoint chlorination are presented below.

### Chlorine Dosage Rate

- Relatively clean effluents will require a chlorine dosage of ten times the ammonia concentration, assuming minimal inorganic and organic demand. However, contaminants in the effluent could increase the chlorine requirement considerably due to inorganic and organic demand for chlorine.

### Chlorine Demand

- Chlorine initially reacts with inorganic reducing materials in the effluent. After that demand is satisfied, chlorine reacts with ammonia and then organic compounds. The total chlorine requirement to reach the point where free chlorine residual first appears is referred to as the chlorine demand of the effluent.

### Flash Mixing

- Flash mixing tanks are used to initially contact chlorine with the effluent. Flash mixing ensures intimate contact of the chlorine with the contaminants in the effluent so that reactions can begin immediately and flash mixing ensures that minimal chlorine is lost from the system by diffusion.

### Reaction Time

- Following initial rapid reactions with inorganic reducing materials, and the relatively rapid reaction of chlorine and ammonia, additional reactions of residual chlorine with chlorine demand proceeds more slowly. Therefore, to achieve complete oxidation of chlorine demand, it is important to provide sufficient contact time to allow the reactions to go to completion.



### Key Points for Unit 4 – Nitrogen Removal

- The most common method of biological nitrogen removal is nitrification/denitrification.
- The most common method of physically removing nitrogen from wastewater is ammonia stripping.
- The overall goal of nitrification/denitrification is to remove nitrogen compounds, especially ammonia, from wastewater. This is accomplished by converting ammonia nitrogen to nitrates and subsequently converting nitrates to nitrogen gas, which leaves the wastewater and enters the atmosphere.
- One of the most important factors necessary to achieve nitrification is a sufficient sludge age. The sludge age must be on the order of 10 days or greater to develop a population of nitrifying microorganisms that is large enough to achieve substantial nitrification.
- Nitrogen is removed from wastewater in the ammonia stripping process by the forced removal of ammonia gas from the wastewater.
- Ammonia is either discharged to atmosphere, if the mass of ammonia is small, or the effluent air stream is treated to remove the ammonia gas before the air is released to atmosphere.
- Ammonia stripping processes are sensitive to both pH and temperature.
- Chlorine demand is often defined as the difference between the amount of chlorine added to wastewater and the amount of free available chlorine remaining at the end of a specified contact period.
- The chlorine dosage would have to be ten times the ammonia concentration for effective removal assuming minimal inorganic and organic demand in the wastewater.



### Exercise for Unit 4 – Nitrogen Removal

1. Explain how the breakpoint chlorination process works.

---

---

---

---

2. What is the appropriate application for breakpoint chlorination?

---

---

---

---

## CHEMICAL NITROGEN REMOVAL BY BREAKPOINT CHLORINATION

---

<sup>1</sup> John G.M. Gonzales, "Chapter 6: Nitrogen Removal," in *Advance Waste Treatment*, (Sacramento, CA: California State University, Sacramento Foundation, 1998), p. 489.

<sup>2</sup> Gonzales, p. 497.

<sup>3</sup> Gonzales, p.497.

<sup>4</sup> Gonzales, p. 505.

<sup>5</sup> Gonzales, p. 493.

<sup>6</sup> Gonzales, p. 502.

<sup>7</sup> Gonzales, p. 502.

<sup>8</sup> Gonzales, p. 502.

<sup>9</sup> Gonzales, p. 508.

<sup>10</sup> Gonzales, p. 509.

<sup>11</sup> Gonzales, p. 511.