

FIRE PREVENTION

CONTINUING EDUCATION UNIT PROFESSIONAL DEVELOPMENT COURSE

.8 CEUs, 8 PDHs, 8 T.C.s



Printing and Saving Instructions

The best thing to do is to download this pdf document to your computer desktop and open it with Adobe Acrobat reader.

Abode Acrobat reader is a free computer software program and you can find it at Abode Acrobat's website.

You can complete the course by viewing the course materials on your computer or you can print it out. We give you permission to print this document.

Printing Instructions: If you are going to print this document, this document is designed to be printed double-sided or duplexed but can be single-sided.

This course booklet does not have the assignment. Please visit our website and download the assignment also.

Internet Link to Assignment...

<http://www.abctlc.com/PDF/Fire%20Prevention%20Assignment.pdf>

State Approval Listing Link, check to see if your State accepts or has pre-approved this course. Not all States are listed. Not all courses are listed. If the course is not accepted for CEU credit, we will give you the course free if you ask your State to accept it for credit.

Professional Engineers; Most states will accept our courses for credit but we do not officially list the States or Agencies acceptance or approvals.

State Approval Listing URL...

<http://www.tlch2o.com/PDF/CEU%20State%20Approvals.pdf>

You can obtain a printed version from TLC for an additional \$49.95 plus shipping charges.



Fire Prevention

Workplace fires and explosions kill 200 and injure more than 5,000 workers each year. In 1995, more than 75,000 workplace fires cost businesses more than \$2.3 billion. ***"Fires wreak havoc among workers and their families and destroy thousands of businesses each year, putting people out of work and severely impacting their livelihoods,"*** said Secretary of Labor Robert B. Reich (1996, October 8). ***"The human and financial toll underscores the serious nature of workplace fires."***

Building Fire Exits

- ✓ Each workplace building must have at least two means of escape remote from each other to be used in a fire emergency.

- ✓ Fire doors must not be blocked or locked to prevent emergency use when employees are within the buildings. Delayed opening of fire doors is permitted when an approved alarm system is integrated into the fire door design.

- ✓ Exit routes from buildings must be clear and free of obstructions and properly marked with signs designating exits from the building.



Blocked Fire Exit

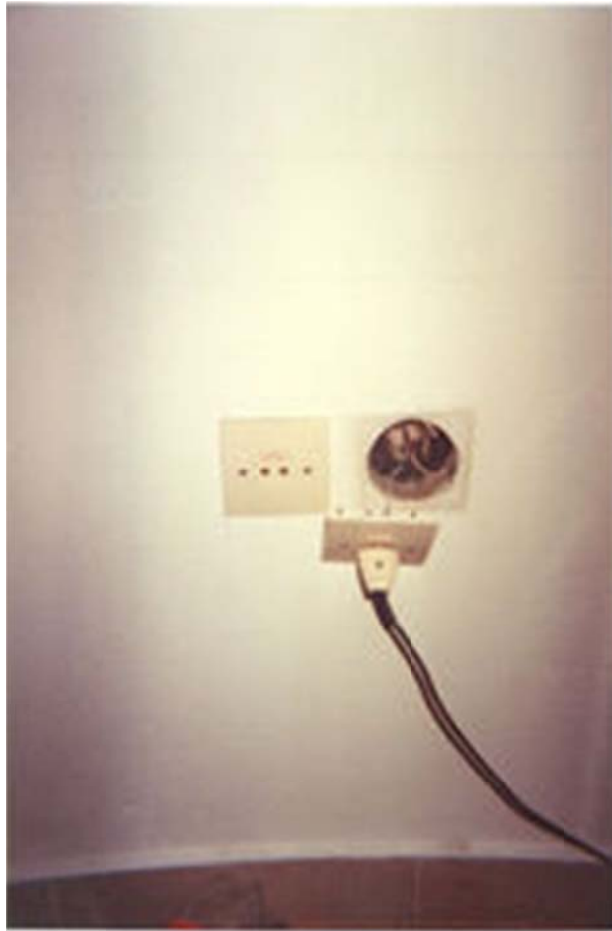

Unsafe, live electrical outlet



Dangerous Electrical Outlet



Blocked Fire Exit

CEU Course Description

Fire Prevention CEU Training Course

The basic goal of the **Fire Prevention Program** and "**Emergency action plan**" - 1910.38(a)(1) are to make sure employers and employees know about potential fire hazards, how to recognize them and, most importantly, how to protect themselves and correct the hazards. This course is designed to help reduce the possible incidence of fire related illness and injuries.

Prerequisites: None

Course Procedures for Registration and Support

All of Technical Learning College correspondence courses have complete registration and support services offered. Delivery of services will include, e-mail, web site, telephone, fax and mail support. TLC will attempt immediate and prompt service.

When a student registers for a distance or correspondence course, he/she is assigned a start date and an end date. It is the student's responsibility to note dates for assignments and keep up with the course work.

If a student falls behind, he/she must contact TLC and request an end date extension in order to complete the course. It is the prerogative of TLC to decide whether to grant the request. You may be required to pay \$40.00. All students will be tracked by their social security number or a unique number will be assigned to the student.

Instructions for Written Assignments

The Fire Prevention CEU correspondence course will have a True/False type of an exam. TLC will require that the document is typed and preferably e-mailed to TLC. You may find an extra copy of the assignment and Student/Course Support on TLC's website under the Assignment Page.

Feedback Mechanism (examination procedures)

Each student will receive a feedback form as part of their study packet. You will be able to find this form in the rear of the course or lesson.

Security and Integrity

All students are required to do their own work. All lesson sheets and final exams are not returned to the student to discourage sharing of answers. Any fraud or deceit and the student will forfeit all fees and the appropriate agency will be notified.

Required Texts

The Fire Prevention course does not require any course materials. Course is complete.

Recordkeeping and Reporting Practices

TLC will keep all student records for a minimum of seven years. It is your responsibility to give the completion certificate to the appropriate agencies.

ADA Compliance

TLC will make reasonable accommodations for persons with documented disabilities. Students should notify TLC and their instructors of any special needs. Course content may vary from this outline to meet the needs of this particular group.

Educational Mission

The educational mission of TLC is:

To provide TLC students with comprehensive and ongoing training in the theory and skills needed for the environmental education field,

To provide TLC students opportunities to apply and understand the theory and skills needed for a successful career,

To provide opportunities for TLC students to learn and practice environmental educational skills with members of the community for the purpose of sharing diverse perspectives and experience,

To provide a forum in which students can exchange experiences and ideas related to environmental education,

To provide a forum for the collection and dissemination of current information related to environmental education, and to maintain an environment that nurtures academic and personal growth.

Copyright Notice

©2005 Technical Learning College (TLC) No part of this work may be reproduced or distributed in any form or by any means without TLC's prior written approval. Permission has been sought for all images and text where we believe copyright exists and where the copyright holder is traceable and contactable. All material that is not credited or acknowledged is the copyright of Technical Learning College. This information is intended for educational purposes only. Most uncredited photographs have been taken by TLC instructors or TLC students. We will be pleased to hear from any copyright holder and will make good on your work if any unintentional copyright infringements were made as soon as these issues are brought to the editor's attention.

Every possible effort is made to ensure that all information provided in this course is accurate. All written, graphic, photographic or other material is provided for information only. Therefore, Technical Learning College accepts no responsibility or liability whatsoever for the application or misuse of any information included herein. Requests for permission to make copies should be made to the following address:

TLC

P.O. Box 420

Payson, AZ 85547-0420

Information in this document is subject to change without notice. TLC is not liable for errors or omissions appearing in this document.

TABLE OF CONTENTS

Characteristics of Fire	13
Fire Triangle	15
Classifications of Fuels	17
Facts about Fire	19
Fire Prevention	21
OSHA Emergency Action Planning	23
Fire Prevention Measures	27
Flammable Materials Checklist	31
Elimination of Ignition Sources	33
Fire Extinguishers	35
Should I Try to Fight a Fire?	39
P.A.S.S.	41
Emergencies and Fire	47
Fire Emergency Procedures	49
Emergency Evacuation Planning	51
Fire Suppression	57
Carbon Monoxide	61
Smoke Detectors	63
Right To Know	69
Hazardous & Flammable Chemicals	73
MSDS Terminology	75
Colors, Numbers and Codes	77
High Rise Fire Safety	79
Rural Fire	81
Fire Definitions	83
OSHA Definitions	95
Fire Protection Rule	97
Fixed Fire Fighting Rules	99
Fire Prevention Rule	101
Flammable & Combustible Liquids	103
Flammable Liquid Storage	107
Liquefied Petroleum Gas	111
Temporary Heating Devices	123
Action Plans	125
Inspection Report	137

Characteristics of Fire

Below are some simple facts that explain the particular characteristics of fire.

Fire is FAST!

There is little time!

In less than 30 seconds a small flame can get completely out of control and turn into a major fire. It only takes minutes for thick black smoke to fill a house. In minutes, a house can be engulfed in flames. Most fires occur in the home when people are asleep. If you wake up to a fire, you won't have time to grab valuables because fire spreads too quickly and the smoke is too thick. There is only time to escape.

Fire is HOT!

Heat is more threatening than flames.

A fire's heat alone can kill. Room temperatures in a fire can be 100 degrees at floor level and rise to 600 degrees at eye level. Inhaling this super-hot air will scorch your lungs. This heat can melt clothes to your skin. In five minutes a room can get so hot that everything in it ignites at once: this is called flashover.

Fire is DARK!

Fire isn't bright, it's pitch black.

Fire starts bright, but quickly produces black smoke and complete darkness. If you wake up to a fire you may be blinded, disoriented and unable to find your way around the home you've lived in for years.

Fire is DEADLY!

Smoke and toxic gases kill more people than flames do.

Fire uses up the oxygen you need and produces smoke and poisonous gases that kill. Breathing even small amounts of smoke and toxic gases can make you drowsy, disoriented and short of breath. The odorless, colorless fumes can lull you into a deep sleep before the flames reach your door. You may not wake up in time to escape.





Never fight a fire larger than a trash can size.

The Fire Triangle

In order to understand how fire extinguishers work, you first need to know a little bit about fire.

Four things must be present at the same time in order to produce fire:

- Enough **oxygen** to sustain combustion,
- Enough **heat** to raise the material to its ignition temperature,
- Some sort of **fuel** or combustible material, and
- The **chemical, exothermic reaction** that is fire.

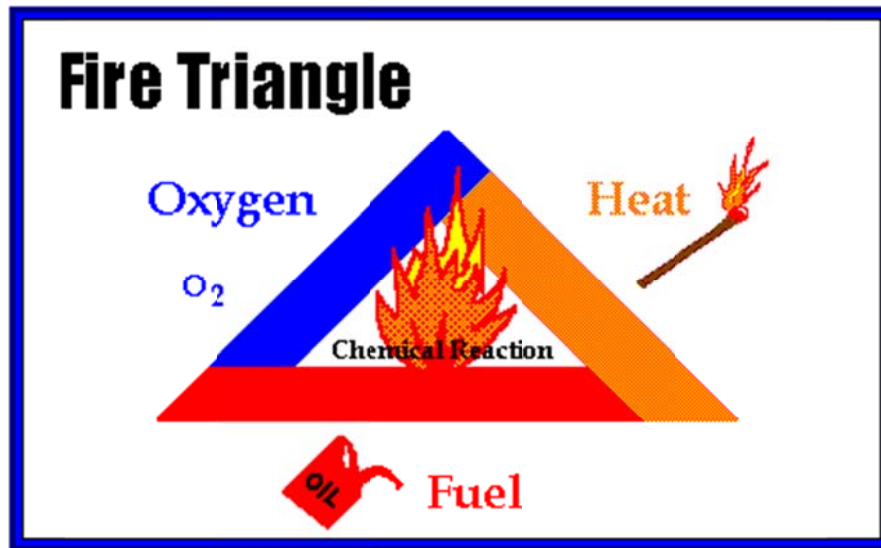

Oxygen, heat, and fuel are frequently referred to as the "**fire triangle**." Add in the fourth element, the chemical reaction, and you actually have a fire "**tetrahedron**." The important thing to remember is: **take any of these four things away, and you will not have a fire or the fire will be extinguished.**

Essentially, fire extinguishers put out fire by taking away one or more elements of the fire triangle/tetrahedron.

Fire safety, at its most basic, is based upon the principle of keeping fuel sources and ignition sources separate.

The percentage of combustible gas in the air is important, too. For example, a manhole filled with fresh air is gradually filled by a leak of combustible gas such as methane or natural gas, mixing with the fresh air. As the ratio of gas to air changes, the sample passes through three ranges: lean, explosive and rich.

In the lean range there isn't enough gas in the air to burn. On the other hand, the rich range has too much gas and not enough air. However, the explosive range has just the right combination of gas and air to form an explosive mixture.

Care must be taken, however, When a mixture is too rich, because dilution with fresh air could bring the mixture into the flammable or explosive range. An analogy is the automobile that won't start on a cold morning (a lean atmosphere because the liquid gasoline has not vaporized sufficiently), but can be flooded with too much gasoline (a rich atmosphere with too much vaporization). Eventually, when the right mixture of gas and air finally exists (explosive), the car starts.

The Fire Tetrahedron

Modern day thinking now accepts there is a fourth element required to sustain combustion. It is **Chemical Reaction** and must be present with all the other elements at the same time in order to produce fire. The four elements are:-

- Enough **oxygen** to sustain combustion,
- Enough **heat** to raise the material to its ignition temperature,
- Some sort of **fuel** or combustible material, and
- The **chemical, exothermic reaction** that is fire.

Once you have three sides of the fire triangle you promote a fourth element, a chemical reaction, consequently you have a fire "**Tetrahedron.**" The important thing to remember is, **take any of these four things away, and you will not have a fire or the fire will be extinguished.**

To extinguish a fire by the fourth element you need to interfere with the chemical reaction. One way, is to mop up the free radicals in the chemical reaction using certain chemicals. BCF and other Halon extinguishers will achieve this, it also creates an inert gas barrier, however this type of extinguisher is being phased out.

In the future other extinguishing agents may be found using this principle.

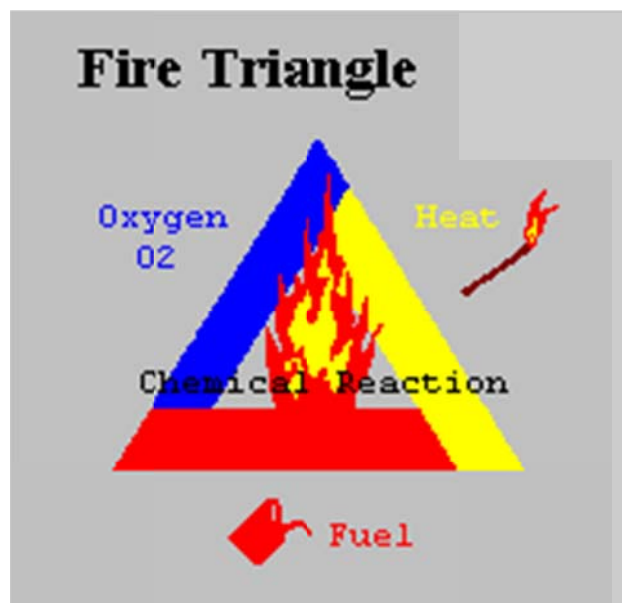



Not all fires are the same, and they are classified according to the type of fuel that is burning. If you use the wrong type of fire extinguisher on the wrong class of fire, you can, in fact, make matters worse. It is therefore very important to understand the four different fire classifications.

Class A - Wood, paper, cloth, trash, plastics

Solid combustible materials that are not metals.

Class B - Flammable liquids: gasoline, oil, grease, acetone

Any non-metal in a liquid state, on fire. This classification also includes flammable gases.

Class C - Electrical: energized electrical equipment

As long as it's "plugged in," it would be considered a class C fire.

Class D - Metals: potassium, sodium, aluminum, magnesium

Unless you work in a laboratory or in an industry that uses these materials, it is unlikely you'll have to deal with a Class D fire. It takes special extinguishing agents (Metal-X, foam) to fight such a fire.

Most fire extinguishers will have a pictograph label telling you which classifications of fire the extinguisher is designed to fight. For example, a simple water extinguisher might have a label like the one below, indicating that it should only be used on Class A fires.



An empty fire extinguisher. Common in business settings. Bad news.



Fire Extinguisher without a discharge hose. A disaster waiting to happen.



Dangerous Electrical Wiring. Fire waiting to happen.

Facts on Fire

Fire in the United States

- ✓ The U.S. has one of the highest fire death rates in the industrialized world. For 1998, the U.S. fire death rate was 14.9 deaths per million population.
- ✓ Between 1994 and 1998, an average of 4,400 Americans lost their lives and another 25,100 were injured annually as the result of fire.
- ✓ About 100 firefighters are killed each year in duty-related incidents.
- ✓ Each year, fire kills more Americans than all natural disasters combined.
- ✓ Fire is the third leading cause of accidental death in the home; at least 80 percent of all fire deaths occur in residences.
- ✓ About 2 million fires are reported each year. Many others go unreported, causing additional injuries and property loss.
- ✓ Direct property loss due to fires is estimated at \$8.6 billion annually.
- ✓ Where Fires Occur
- ✓ There were 1,755,000 fires in the United States in 1998. Of these:
- ✓ 41% were Outside Fires
- ✓ 29% were Structure Fires
- ✓ 22% were Vehicle Fires
- ✓ 8 % were fires of other types
- ✓ Residential fires represent 22 percent of all fires and 74 percent of structure fires.

Fires in 1-2 family dwellings most often start in the:

1. Kitchen 23.5%
2. Bedroom 12.7%
3. Living Room 7.9%
4. Chimney 7.1%
5. Laundry Area 4.7%

Apartment fires most often start in the:

1. Kitchen 46.1%
2. Bedroom 12.3%
3. Living Room 6.2%
4. Laundry Area 3.3%
5. Bathroom 2.4%



The South has the highest fire death rate per-capita with 18.4 civilian deaths per million population.

80 percent of all fatalities occur in the home. Of those, approximately 85 percent occur in single-family homes and duplexes.

Causes of Fires and Fire Deaths

- ✓ Cooking is the leading cause of home fires in the U.S. It is also the leading cause of home fire injuries. Cooking fires often result from unattended cooking and human error, rather than mechanical failure of stoves or ovens.
- ✓ Careless smoking is the leading cause of fire deaths. Smoke alarms and smolder-resistant bedding and upholstered furniture are significant fire deterrents.
- ✓ Heating is the second leading cause of residential fires and the second leading cause of fire deaths. However, heating fires are a larger problem in single family homes than in apartments. Unlike apartments, the heating systems in single family homes are often not professionally maintained.
- ✓ Arson is both the third leading cause of residential fires and residential fire deaths. In commercial properties, arson is the major cause of deaths, injuries and dollar loss.

Who is Most at Risk

- ✓ Senior citizens age 70 and over and children under the age of 5 have the greatest risk of fire death.
- ✓ The fire death risk among seniors is more than double the average population.
- ✓ The fire death risk for children under age 5 is nearly double the risk of the average population.
- ✓ Children under the age of 10 accounted for an estimated 17 percent of all fire deaths in 1996.
- ✓ Men die or are injured in fires almost twice as often as women.
- ✓ African Americans and American Indians have significantly higher death rates per capita than the national average.
- ✓ Although African Americans comprise 13 percent of the population, they account for 26 percent of fire deaths.

People with Special Needs

More than 4,000 Americans die each year in fires, and more than 25,000 are injured.

Special populations such as older adults, people with disabilities, the deaf and hard of hearing and the visually impaired can significantly increase their chances of surviving a fire by practicing proven fire safety precautions.

Why are Special Populations at Risk?

Special populations are at risk for a number of reasons:

- ✓ Decreased mobility, health, sight, and hearing may limit a person's ability to take the quick action necessary to escape during a fire emergency.
- ✓ Depending on physical limitations, many of the actions an individual can take to protect themselves from the dangers of fire may require help from a caretaker, neighbor, or outside source.

Fire Prevention

Workplace fires and explosions kill 200 and injure more than 5,000 workers each year. In 1995, more than 75,000 workplace fires cost businesses more than \$2.3 billion. "***Fires wreak havoc among workers and their families and destroy thousands of businesses each year, putting people out of work and severely impacting their livelihoods,***" said Secretary of Labor Robert B. Reich (1996, October 8). "***The human and financial toll underscores the serious nature of workplace fires.***"

Building Fire Exits

- ✓ Each workplace building must have at least two means of escape remote from each other to be used in a fire emergency.
- ✓ Fire doors must not be blocked or locked to prevent emergency use when employees are within the buildings. Delayed opening of fire doors is permitted when an approved alarm system is integrated into the fire door design.
- ✓ Exit routes from buildings must be clear and free of obstructions and properly marked with signs designating exits from the building.





OSHA Rule 1910.38(a)

"Emergency action plan" -

1910.38(a)(1)

"Scope and application." This paragraph (a) applies to all emergency action plans required by a particular OSHA standard. The emergency action plan shall be in writing (except as provided in the last sentence of paragraph (a)(5)(iii) of this section) and shall cover those designated actions employers and employees must take to ensure employee safety from fire and other emergencies.

1910.38(a)(2)

"Elements." The following elements, at a minimum, shall be included in the plan:

1910.38(a)(2)(i)

Emergency escape procedures and emergency escape route assignments;

1910.38(a)(2)(ii)

Procedures to be followed by employees who remain to operate critical plant operations before they evacuate;

1910.38(a)(2)(iii)

Procedures to account for all employees after emergency evacuation has been completed;

.. 1910.38(a)(2)(iv)

1910.38(a)(2)(iv)

Rescue and medical duties for those employees who are to perform them;

1910.38(a)(2)(v)

The preferred means of reporting fires and other emergencies; and

1910.38(a)(2)(vi)

Names or regular job titles of persons or departments who can be contacted for further information or explanation of duties under the plan.

1910.38(a)(3)

"Alarm system."

1910.38(a)(3)(i)

The employer shall establish an employee alarm system which complies with 1910.165.

1910.38(a)(3)(ii)

If the employee alarm system is used for alerting fire brigade members, or for other purposes, a distinctive signal for each purpose shall be used.

1910.38(a)(4)

"Evacuation." The employer shall establish in the emergency action plan the types of evacuation to be used in emergency circumstances.

1910.38(a)(5)

"Training."

1910.38(a)(5)(i)

Before implementing the emergency action plan, the employer shall designate and train a sufficient number of persons to assist in the safe and orderly emergency evacuation of employees.

.. 1910.38(a)(5)(ii)

1910.38(a)(5)(ii)

The employer shall review the plan with each employee covered by the plan at the following times:

1910.38(a)(5)(ii)(A)

Initially when the plan is developed,

1910.38(a)(5)(ii)(B)

Whenever the employee's responsibilities or designated actions under the plan change, and

1910.38(a)(5)(ii)(C)

Whenever the plan is changed.

1910.38(a)(5)(iii)

The employer shall review with each employee upon initial assignment those parts of the plan which the employee must know to protect the employee in the event of an emergency. The written plan shall be kept at the workplace and made available for employee review. For those employers with 10 or fewer employees the plan may be communicated orally to employees and the employer need not maintain a written plan.

1910.38(b)

"Fire prevention plan" -

1910.38(b)(1)

"Scope and application." This paragraph (b) applies to all fire prevention plans required by a particular OSHA standard. The fire prevention plan shall be in writing, except as provided in the last sentence of paragraph (b)(4)(ii) of this section.

..1910.38(b)(2)

1910.38(b)(2)

"Elements." The following elements, at a minimum, shall be included in the fire prevention plan:

1910.38(b)(2)(i)

A list of the major workplace fire hazards and their proper handling and storage procedures, potential ignition sources (such as welding, smoking and others) and their control procedures, and the type of fire protection equipment or systems which can control a fire involving them;

1910.38(b)(2)(ii)

Names or regular job titles of those personnel responsible for maintenance of equipment and systems installed to prevent or control ignitions or fires; and

1910.38(b)(2)(iii)

Names or regular job titles of those personnel responsible for control of fuel source hazards.

1910.38(b)(3)

"Housekeeping." The employer shall control accumulations of flammable and combustible waste materials and residues so that they do not contribute to a fire emergency. The housekeeping procedures shall be included in the written fire prevention plan.

1910.38(b)(4)

"Training."

1910.38(b)(4)(i)

The employer shall apprise employees of the fire hazards of the materials and processes to which they are exposed.

..1910.38(b)(4)(ii)

1910.38(b)(4)(ii)

The employer shall review with each employee upon initial assignment those parts of the fire prevention plan which the employee must know to protect the employee in the event of an emergency. The written plan shall be kept in the workplace and made available for employee review. For those employers with 10 or fewer employees, the plan may be communicated orally to employees and the employer need not maintain a written plan.

1910.38(b)(5)

"Maintenance." The employer shall regularly and properly maintain, according to established procedures, equipment and systems installed on heat producing equipment to prevent accidental ignition of combustible materials. The maintenance procedures shall be included in the written fire prevention plan.

[45 FR 60703, Sept. 12, 1980]



Blocked Fire Exit. Death trap.



The employer shall review with each employee upon initial assignment those parts of the fire prevention plan which the employee must know to protect the employee in the event of an emergency. The written plan shall be kept in the workplace and made available for employee review. For those employers with 10 or fewer employees, the plan may be communicated orally to employees and the employer need not maintain a written plan.

Fire Prevention Measures

Fire prevention measures propose to reduce the incidence of fires by eliminating opportunities for ignition of flammable materials.

Flammable and Combustible Materials

A. Substitution

Flammable liquids sometimes may be substituted by relatively safe materials in order to reduce the risk of fires. Any substituted material should be stable and nontoxic and should either be nonflammable or have a high flashpoint.

B. Storage

Flammable and combustible liquids require careful handling at all times. The proper storage of flammable liquids within a work area is very important in order to protect personnel from fire and other safety and health hazards.



1) Cabinets

Not more than 120 gallons of Class I, Class II, and Class IIIA liquids may be stored in a storage cabinet. Of this total, not more than 60 gallons may be Class I and II liquids. Not more than three such cabinets (120 gallons each) may be located in a single fire area except in an industrial area.



Table 1. Maximum allowable capacity of containers and portable tanks

Container	Flammable Liquids		Combustible Liquids		
	1A	1B	1C	II	III
Glass or approved plastic ¹	1 pt ²	1 qt ²	1 gal	1 gal	1 gal
Metal (Other than DOT drums)	1 gal	5 gal	5 gal	5 gal	5 gal
Safety Cans	2 gal	5 gal	5 gal	5 gal	5 gal
Metal drums (DOT specifications)	60 gal	60 gal	60 gal	60 gal	60 gal
Approved portable tanks	660 gal	660 gal	660 gal	660 gal	660 gal

(1) Nearest metric size is also acceptable for the glass and plastic
 (2) One gallon or nearest metric equivalent size may be used if metal and labeled with their contents.



A fire resistant file cabinet that is burned completely and beside it are modern flammable liquids storage cabinets.

2) Containers

The capacity of flammable and combustible liquid containers will be in accordance with Table 1.

3)

Storage Inside Buildings.

Where approved storage cabinets or rooms are not provided, inside storage will comply with the following basic conditions:

a. The storage of any flammable or combustible liquid shall not physically obstruct a means of egress from the building or area.

b. Containers of flammable or combustible liquids will remain tightly sealed except when transferred, poured or applied. Remove only that portion of liquid in the storage container required to accomplish a particular job.

c. If a flammable and combustible liquid storage building is used, it will be a one-story building devoted principally to the handling and storing of flammable or combustible liquids. The building will have 2-hour fire-rated exterior walls having no opening within 10 feet of such storage.

d. Flammable paints, oils, and varnishes in 1 or 5 gallon containers, used for building maintenance purposes, may be stored temporarily in closed containers outside approved storage cabinets or room if kept at the job site for less than 10 calendar days.

C. Ventilation

Every inside storage room will be provided with a continuous mechanical exhaust ventilation system. To prevent the accumulation of vapors, the location of both the makeup and exhaust air openings will be arranged to provide, as far as practical, air movement directly to the exterior of the building and if ducts are used, they will not be used for any other purpose.





Firefighter preparing PPE or “Turnouts”.



Inspecting SCBA equipment.

Flammable and Combustible Materials Checklist

	Are combustible scrap, debris, and waste materials (oily rags, etc.) stored in covered metal receptacles and removed from the worksite promptly?
	Is proper storage practiced to minimize the risk of fire including spontaneous combustion?
	Are approved containers and tanks used for the storage and handling of flammable and combustible liquids?
	Are all connections on drums and combustible liquid piping, vapor and liquid tight?
	Are all flammable liquids kept in closed containers when not in use (for example, parts cleaning tanks, pans, etc.)?
	Are bulk drums of flammable liquids grounded and bonded to containers during dispensing?
	Do storage rooms for flammable and combustible liquids have explosion-proof lights?
	Do storage rooms for flammable and combustible liquids have mechanical or gravity ventilation?
	Is liquefied petroleum gas stored, handled, and used in accordance with safe practices and standards?
	Are "NO SMOKING" signs posted on liquefied petroleum gas tanks?
	Are liquefied petroleum storage tanks guarded to prevent damage from vehicles?
	Are all solvent wastes and flammable liquids kept in fire-resistant, covered containers until they are removed from the worksite?
	Is vacuuming used whenever possible rather than blowing or sweeping combustible dust? Are firm separators placed between containers of combustibles or flammables, when stacked one upon another, to assure their support and stability?
	Are fuel gas cylinders and oxygen cylinders separated by distance, and fire-resistant barriers, while in storage?
	Are fire extinguishers selected and provided for the types of materials in areas where they are to be used?
	Class A Ordinary combustible material fires.
	Class B Flammable liquid, gas or grease fires.
	Class C Energized-electrical equipment fires.

	Are appropriate fire extinguishers mounted within 75 feet of outside areas containing flammable liquids, and within 10 feet of any inside storage area for such materials?
	Are extinguishers free from obstructions or blockage?
	Are all extinguishers serviced, maintained and tagged at intervals not to exceed 1 year?
	Are all extinguishers fully charged and in their designated places?
	Where sprinkler systems are permanently installed, are the nozzle heads so directed or arranged that water will not be sprayed into operating electrical switch boards and equipment?
	Are "NO SMOKING" signs posted where appropriate in areas where flammable or combustible materials are used or stored?
	Are safety cans used for dispensing flammable or combustible liquids at a point of use?
	Are all spills of flammable or combustible liquids cleaned up promptly?
	Are storage tanks adequately vented to prevent the development of excessive vacuum or pressure as a result of filling, emptying, or atmosphere temperature changes?
	Are storage tanks equipped with emergency venting that will relieve excessive internal pressure caused by fire exposure?
	Are "NO SMOKING" rules enforced in areas involving storage and use of hazardous materials?



Elimination of Ignition Sources

D. All nonessential ignition sources must be eliminated where flammable liquids are used or stored. The following is a list of some of the more common potential ignition sources:

- Open flames, such as cutting and welding torches, furnaces, matches, and heaters- these sources should be kept away from flammable liquids operations. Cutting or welding on flammable liquids equipment should not be performed unless the equipment has been properly emptied and purged with a neutral gas such as nitrogen.
- Chemical sources of ignition such as d.c. motors, switched, and circuit breakers- these sources should be eliminated where flammable liquids are handled or stored. Only approved explosion-proof devices should be used in these areas.
- Mechanical sparks- these sparks can be produced as a result of friction. Only nonsparking tools should be used in areas where flammable liquids are stored or handled.
- Static sparks- these sparks can be generated as a result of electron transfer between two contacting surfaces. The electrons can discharge in a small volume, raising the temperature to above the ignition temperature. Every effort should be made to eliminate the possibility of static sparks. Also proper bonding and grounding procedures must be followed when flammable liquids are transferred or transported.

E. Removal of Incompatibles

Materials that can contribute to a flammable liquid fire should not be stored with flammable liquids. Examples are oxidizers and organic peroxides, which, on decomposition, can generate large amounts of oxygen.

F. Flammable Gases

Generally, flammable gases pose the same type of fire hazards as flammable liquids and their vapors. Many of the safeguards for flammable liquids also apply to flammable gases, other properties such as toxicity, reactivity, and corrosivity also must be taken into account.

Also, a gas that is flammable could produce toxic combustion products.





Could these overload circuit be an ignition source?

Or, how about this wiring job? Homeowners are nuts to do electrical work without a licensed contractor.



Fire Extinguishers

A portable fire extinguisher is a "first aid" device and is very effective when used while the fire is small. The use of fire extinguisher that matches the class of fire, by a person who is well trained, can save both lives and property. Portable fire extinguishers must be installed in workplaces regardless of other firefighting measures. The successful performance of a fire extinguisher in a fire situation largely depends on its proper selection, inspection, maintenance, and distribution.

A. Classification of Fires and Selection of Extinguishers

Fires are classified into four general categories depending on the type of material or fuel involved. The type of fire determines the type of extinguisher that should be used to extinguish it.

- 1) Class A fires involve materials such as wood, paper, and cloth which produce glowing embers or char.
- 2) Class B fires involve flammable gases, liquids, and greases, including gasoline and most hydrocarbon liquids which must be vaporized for combustion to occur.
- 3) Class C fires involve fires in live electrical equipment or in materials near electrically powered equipment.
- 4) Class D fires involve combustible metals, such as magnesium, zirconium, potassium, and sodium.

Extinguishers will be selected according to the potential fire hazard, the construction and occupancy of facilities, hazard to be protected, and other factors pertinent to the situation.

B. Location and Marking of Extinguishers

Extinguishers will be conspicuously located and readily accessible for immediate use in the event of fire. They will be located along normal paths of travel and egress. Wall recesses and/or flush-mounted cabinets will be used as extinguisher locations whenever possible.

Extinguishers will be clearly visible. In locations where visual obstruction cannot be completely avoided, directional arrows will be provided to indicate the location of extinguishers and the arrows will be marked with the extinguisher classification.

If extinguishers intended for different classes of fire are located together, they will be conspicuously marked to ensure that the proper class extinguisher selection is made at the time of a fire.

Extinguisher classification markings will be located on the front of the shell above or below the extinguisher nameplate. Markings will be of a size and form to be legible from a distance of 3 feet.

Portable Fire Extinguishers

A fire extinguisher is **NO** substitute for the Fire Department. One third of all people injured by fire are hurt while trying to control it.

Virtually all fires are small at first and might easily be contained if the correct type of extinguisher is readily available and properly used. Fire extinguishers are the first line of defense against unfriendly fires, and should be installed in all homes and businesses.

When used properly, portable fire extinguishers can save lives and property by putting out a small fire or containing it until the fire department arrives.

- ✓ Portable fire extinguishers for home use, however, are not designed to fight large or spreading fires. Even for small fires they are useful only under certain conditions:
- ✓ The operator must know how to use the extinguisher. There is no time to read directions during an emergency.
- ✓ The extinguisher must be within easy reach, in working order, and fully charged.
- ✓ The operator must have a clear escape route that will not be blocked by fire.
- ✓ The extinguisher must match the type of fire being fought. Extinguishers that contain water are unsuitable for use of grease and electrical fires.
- ✓ The extinguisher must be large enough to put out the fire. Many portable extinguishers discharge completely in as few as 8 to 10 seconds.



The four classes of fire extinguishers are:



Class A: Fires that involve ordinary materials such as wood, paper, cloth, and cardboard.



Class B: Fires that involve flammable liquids such as gasoline, oil, and oil-based paint.



Class C: Fires that involve energized electrical equipment, such as appliances, wiring, fuse boxes, and circuit breakers.

Class D fires involve combustible metals, such as magnesium, zirconium, potassium, and sodium.

The fire extinguisher must be appropriate for the type of fire being fought. If you use the wrong kind of fire extinguisher, you can make the fire worse and endanger yourself.

For example, if a water extinguisher is used on an electrical fire, there will be a risk of electrical shock.

Multipurpose fire extinguishers can be used on **A, B, C** classes of fires.

Portable Fire Extinguishers

- ✓ Each workplace building must have a full complement of the proper type of fire extinguisher for the fire hazards present, excepting when employer wish to have employees evacuate instead of fighting small fires.
- ✓ Employees expected or anticipated to use fire extinguishers must be instructed on the hazards of fighting fire, how to properly operate the fire extinguishers available, and what procedures to follow in alerting others to the fire emergency.
- ✓ Only approved fire extinguishers are permitted to be used in workplaces, and they must be kept in good operating condition. Proper maintenance and inspection of this equipment is required of each employer.
- ✓ Where the employer wishes to evacuate employees instead of having them fight small fires there must be written emergency plans and employee training for proper evacuation.

What sizes of fire extinguisher are available?

Portable fire extinguishers are also rated for the size of fire they can handle. This rating will appear on the label - for example, **2A:10B:C**. The larger the numbers, the larger the fire that the extinguisher can put out. Higher-rated models are often much heavier. Make sure you can hold and operate an extinguisher before you buy it.

What should I know about installing and maintaining fire extinguishers?

- ✓ Fire extinguishers should be installed in plain view, above the reach of children, near an escape route and away from stoves and heating appliances.
- ✓ Fire extinguishers require some routine care. Make sure you read your operator's manual to learn how to inspect your fire extinguisher. Follow the manufacturer's instructions on maintaining the extinguisher.
- ✓ Rechargeable models must be serviced after every use (look in the Yellow Pages of your telephone directory under "**Fire Extinguishers**" for local companies that service them). The disposable fire extinguishers can be used only one time and must be replaced after use.



Should I Try to Fight the Fire?

Before you begin to fight a fire:

Make sure everyone has left or is leaving the building.

Make sure the fire department has been called. The Fire Department will be on the way in case the fire cannot be controlled.

Make sure the fire is confined to a small area and is not spreading.

Make sure you have an unobstructed escape route to which the fire will not spread.

Make sure you have read the instructions and know how to use the extinguisher.

Make sure the fire extinguisher is the right type for the fire.

It is reckless to fight a fire in any other circumstances. Instead, leave immediately and close off the area.

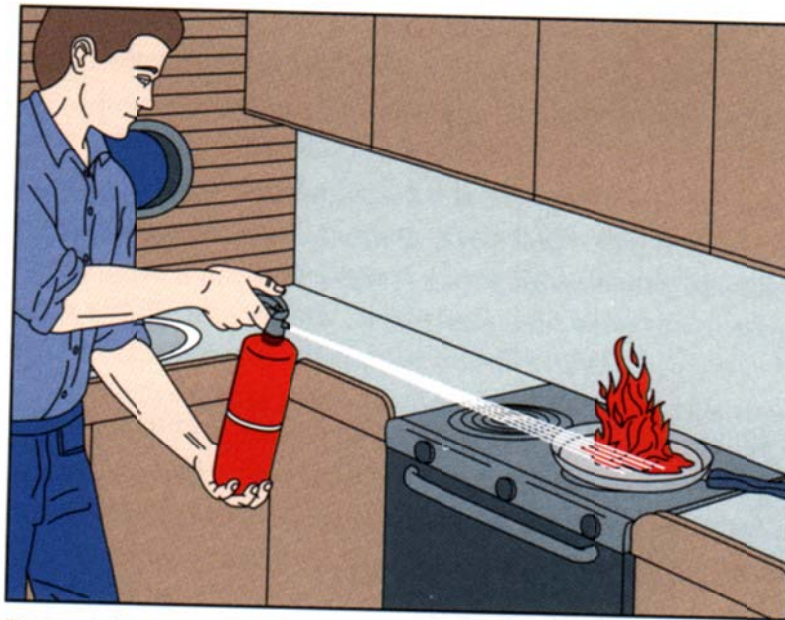

Pull out the extinguisher lock pin and squeeze the two handle levers together. Aim at the base of the flame with a sweeping motion; hold the stream steadily on the base of the flames until you are certain the fire is out. Dry chemical extinguishers are effective for 5 to 15 feet from the nozzle, Halon 1211 for 9 to 15 feet, Halon 1301 up to 6 feet and CO₂ up to 3 feet.



Important tips to remember.

Most fires start small. Except for explosions, fires can usually be brought under control if they are attacked correctly with the right type and size of extinguisher within the first two minutes!

A portable fire extinguisher can save lives and property by putting out a small fire or containing it until the fire department arrives. Before attempting to fight a small fire be sure everyone is out of the building. It is important to have someone call the fire department. If the fire starts to spread or threatens your escape path, get out immediately!

The operator must know how to use the extinguisher, quickly without taking time to read directions during an emergency. Remember that the extinguishers need care and must be recharged after every use.

P.A.S.S.

PULL the pin: this unlocks the operating lever and allows you to discharge the extinguisher. Some extinguishers may have other lever release mechanisms.

AIM low: point the extinguisher nozzle (or hose) at the **BASE** of the fire.



SQUEEZE the lever above the handle: this discharges the extinguishing agent. Releasing the lever will stop the discharge (some extinguishers have a button instead of a lever).

SWEEP from side to side: moving carefully toward the fire, keep the extinguisher aimed at the base of the fire and sweep back and forth until the flames appear to be out. Watch the fire area. If the fire ignites again, repeat the process.

ALWAYS make sure the fire department is called and inspects the fire site, even if you think you have extinguished the fire!

Important tips to remember

Most fires start small. Except for explosions, fires can usually be brought under control if they are attacked correctly with the right type and size of extinguisher within the first two minutes!

A portable fire extinguisher can save lives and property by putting out a small fire or containing it until the fire department arrives. Before attempting to fight a small fire be sure everyone is out of the building. It is important to have someone call the fire department. If the fire starts to spread or threatens your escape path, get out immediately!

The operator must know how to use the extinguisher, quickly without taking time to read directions during an emergency. Remember that the extinguishers need care and must be recharged after every use.

The steps to use a fire extinguisher are P.A.S.S. Pull, Aim, Squeeze, and Sweep. Most portable extinguishers work according to these directions, but some do not. Read and follow the directions on your extinguisher.

If you have the slightest doubt about whether or not to fight a fire - **DON'T!** Get out and close the door behind you.

Portable fire extinguishers can be a useful component of a home fire safety plan, but they aren't the only component. A comprehensive home fire safety plan should include smoke detectors and an evacuation plan.

It is also important to talk about fire safety with your family regularly to re-enforce the evacuation plan, check your smoke detectors' batteries, and review where your fire extinguishers are kept, and how to use them.

C. Condition

Portable extinguishers will be maintained in a fully charged and operable condition. They will be kept in their designated locations at all times when not being used.

When extinguishers are removed for maintenance or testing, a fully charged and operable replacement unit will be provided.

D. Mounting and Distribution of Extinguishers

Extinguishers will be installed on hangers, brackets, in cabinets, or on shelves. Extinguishers having a gross weight not exceeding 40 pounds will be so installed that the top of the extinguisher is not more than 3-1/2 feet above the floor.

Extinguishers mounted in cabinets or wall recesses or set on shelves will be placed so that the extinguisher operating instructions face outward. The location of such extinguishers will be made conspicuous by marking the cabinet or wall recess in a contrasting color which will distinguish it from the normal decor.

Extinguishers must be distributed in such a way that the amount of time needed to travel to their location and back to the fire does not allow the fire to get out of control. OSHA requires that the travel distance for Class A and Class D extinguishers not exceed 75 feet.

The maximum travel distance for Class B extinguishers is 50 feet because flammable liquid fires can get out of control faster than Class A fires.

There is no maximum travel distance specified for Class C extinguishers, but they must be distributed on the basis of appropriate patterns for Class A and B hazards.

E. Inspection and Maintenance

Once an extinguisher is selected, purchased, and installed, it is the responsibility of the facility manager to oversee the inspection, maintenance, and testing of fire extinguishers to ensure that they are in proper working condition and have not been tampered with or physically damaged.

Fire Safety Inspections/Housekeeping

First line supervisors and Safety Committees are responsible for conducting work site surveys at least annually.

These surveys should include observations of worksite safety and housekeeping issues and should specifically address proper storage of chemicals and supplies, unobstructed access to fire extinguishers, and emergency evacuation routes. Also, they should determine if an emergency evacuation plan is present in work areas and that personnel are familiar with the plan.

Emergency Egress

Every exit will be clearly visible, or the route to it conspicuously identified in such a manner that every occupant of the building will readily know the direction of escape from any point. At no time will exits be blocked.

Any doorway or passageway which is not an exit or access to an exit but which may be mistaken for an exit, will be identified by a sign reading "**Not An Exit**" or a sign indicating its actual use (i.e., "Storeroom").

Exits and accesses to exits will be marked by a readily visible sign. Each exit sign (other than internally illuminated signs) will be illuminated by a reliable light source providing not less than 5 foot-candles on the illuminated surface.



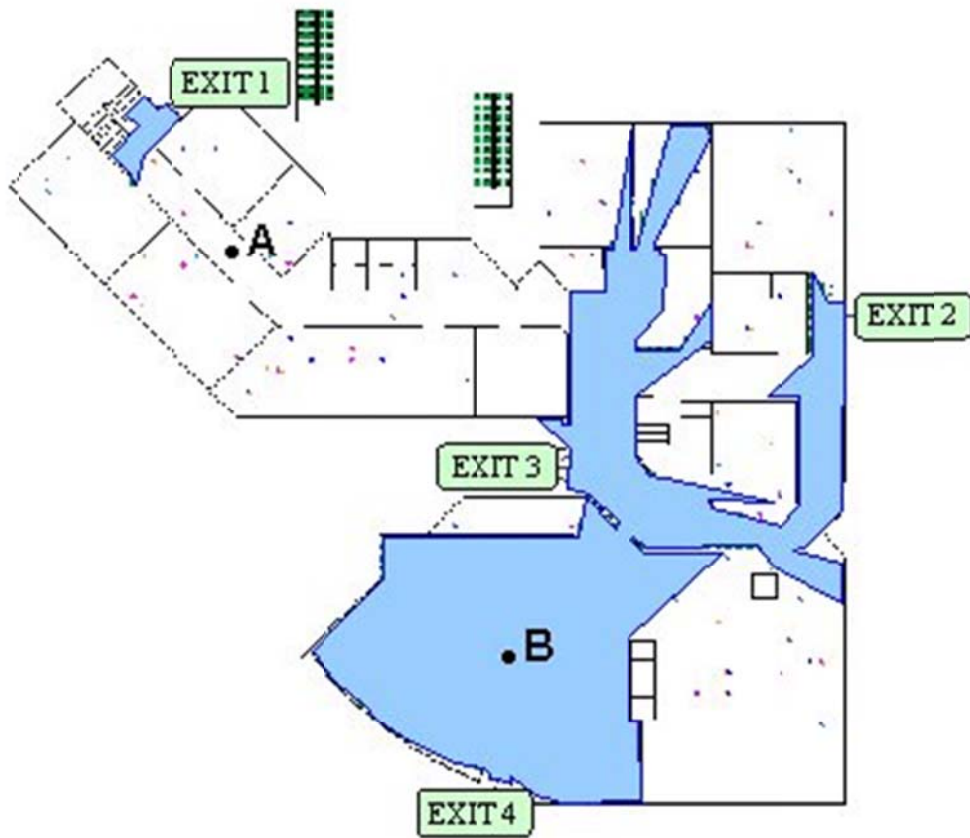

Facilities Design Review

Facilities will be designed in a manner consistent with health and safety regulations and standards of good design. The Engineering Services Office, together with OHS, will ensure that there is appropriate health and safety review of facility concepts, designs, and plans. A formal design review process is currently in place for all new construction efforts.

Occupant Emergency Plan for Persons with Disabilities

The first line supervisor is assigned the responsibility to assist Persons with Disabilities under their supervision. An alternate assistant will be chosen by the supervisor. The role of the two assistants is to report to their assigned person, and to either assist in evacuation or assure that the PWD is removed from danger.

- Supervisors, alternates, and the person with a disability will be trained by OHS on available escape routes and methods.
- A list of persons with disabilities is kept in the Office of Health and Safety. This list is updated by the Emergency coordinators, emergency monitors, OHS, the Office of Personnel Management, and the PWD Committee.
- Visitors who have disabilities will be assisted in a manner similar to that of employees. The Host of the person with disabilities will assist in their evacuation.



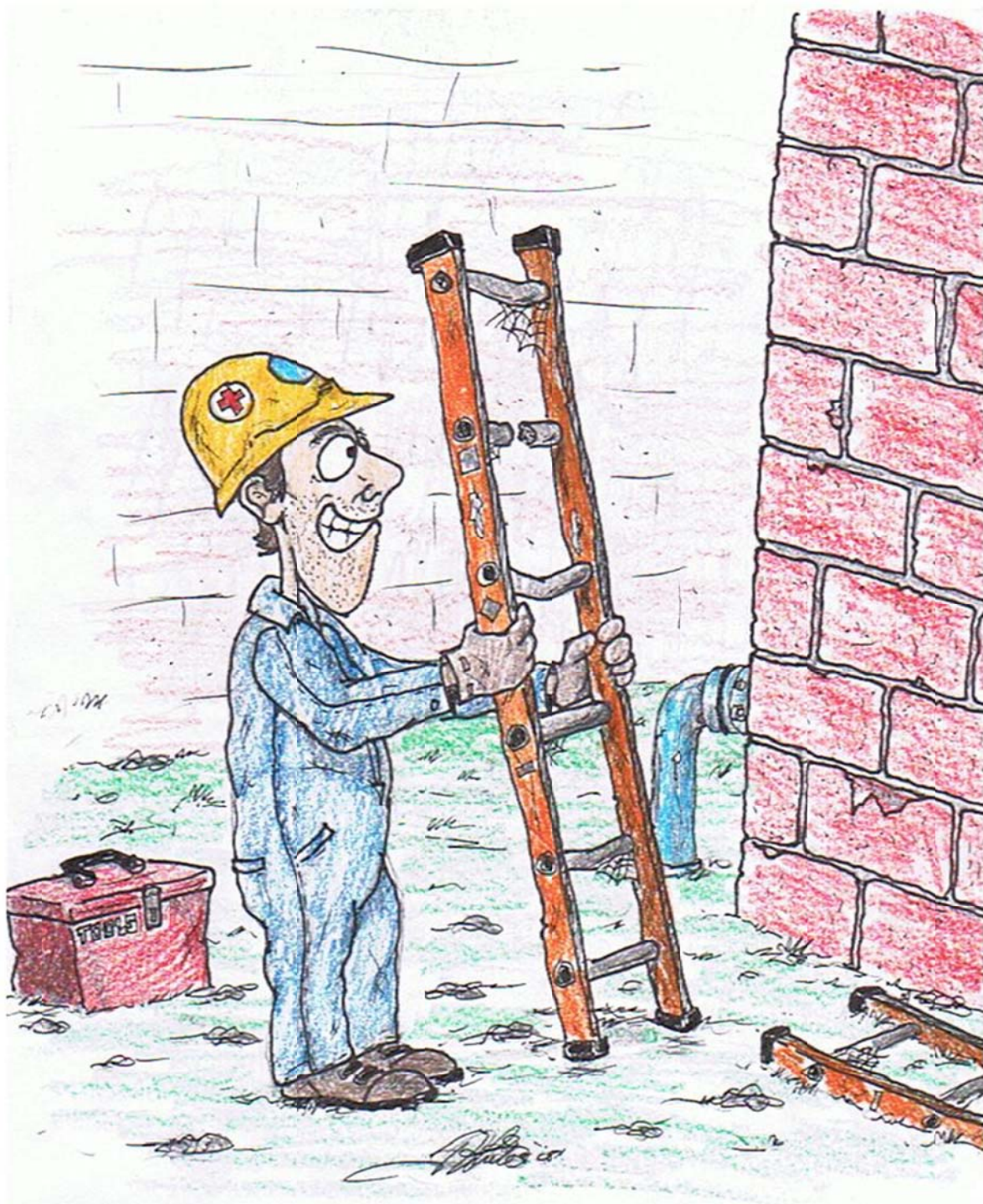

In the event of a fire, remember time is the biggest enemy and every second counts!

Escape first, and then call for help. Develop a home fire escape plan and designate a meeting place outside. Make sure everyone in the family knows two ways to escape from every room. Practice feeling your way out with your eyes closed. Never stand up in a fire, always crawl low under the smoke and try to keep your mouth covered. Never return to a burning building for any reason; it may cost you your life.

Emergencies Involving Fire

A. Fire Alarms

In the event of a fire emergency, a fire alarm will sound for the building.

B. Evacuation Routes and Plans

Each facility shall have an emergency evacuation plan. All emergency exits shall conform to NFPA standards.

Should evacuation be necessary, go to the nearest exit or stairway and proceed to an area of refuge outside the building. Most stairways are fire resistant and present barriers to smoke if the doors are kept closed.

Do not use elevators. Should the fire involve the control panel of the elevator or the electrical system of the building, power in the building may be cut and you could be trapped between floors. Also, the elevator shaft can become a flue, lending itself to the passage and accumulation of hot gases and smoke generated by the fire.

C. Emergency Coordinators

Emergency Coordinators will be responsible for verifying personnel have evacuated from their assigned areas.



1910.38(a)(2)(vi)

Names or regular job titles of persons or departments who can be contacted for further information or explanation of duties under the plan.



While enjoying electric TVs, radios and other appliances, we may forget they can cause shocks and fires. In 1990, bad plugs, cords, switches, and outlets caused about 13,000 home fires and nearly 200 deaths. Most electrical fires and injuries can be prevented. People should take the time to have their electrical systems inspected and learn about electrical safety.

- **Tips on electrical safety:**
 - **People who live in homes that are more than 10 years old should consider having the wiring inspected. If your home is more than 40 years old, an inspection is overdue. Be sure to consult with your local building inspector before making repairs.**
 - **Never place electric cords under rugs or bedding. Heat or sparks from these cords could cause a fire.**
 - **Follow the safety tips on new appliances.**
 - **Check electrical cords for signs of wear. Replace frayed or cracked cords to prevent shocks and fires.**

Fire Emergency Procedures (Example)

If you discover a fire:

1. Activate the nearest fire alarm.
2. Notify the fire department by dialing 9-911. Give your location, the nature of the fire, and your name.
3. Notify your Emergency Coordinator and other occupants.

Fight the fire ONLY if:

1. The fire department has been notified of the fire, AND
2. The fire is small and confined to its area of origin, AND
3. You have a way out and can fight the fire with your back to the exit, AND
4. You have the proper extinguisher, in good working order, AND know how to use it.
5. If you are not sure of your ability or the fire extinguisher's capacity to contain the fire, leave the area.

If you hear a fire alarm:

1. Evacuate the area. Close windows, turn off gas jets, and close doors as you leave.
2. Leave the building and move away from exits and out of the way of emergency operations.
3. Assemble in a designated area.
4. Report to the monitor so he/she can determine that all personnel have evacuated your area.
5. Remain outside until competent authority (Physical Security, Office of Health and Safety, or your supervisor) states that it is safe to re-enter.

Evacuation Routes

1. Learn at least two escape routes, and emergency exits from your area.
2. Never use an elevator as part of your escape route.
3. Learn to activate a fire alarm.
4. Learn to recognize alarm sounds.
5. Take an active part in fire evacuation drills.

Have a Sound Fire Safety and Escape Plan

It is vitally important to make and practice escape plans. In the event of a fire, remember, time is the biggest enemy and every second counts!

- ✓ Involve the assistance of a building manager, family member, or an entrusted friend when practicing your fire escape plan.
- ✓ Know at least two exits from every room.
- ✓ If you use a walker or wheelchair, check all exits to make sure they get through the doorways.
- ✓ Practice opening locked or barred doors and windows.
- ✓ When a fire occurs, do not waste any time saving property. Leave the home immediately. Once out, stay out.

DEVELOP A HOME FIRE SAFETY PLAN

People with mobility difficulties should be encouraged to have their bedroom on the ground floor and as close as possible to an exit.

- ✓ If necessary, have a ramp available for emergency exits.
- ✓ Unless instructed by the fire department, never use an elevator during a fire.
- ✓ Be sure your street address is clearly marked and visible from the street.
- ✓ Know which local emergency services are available and have those numbers posted or memorized.

INFORM OTHERS OF YOUR SPECIAL NEEDS

Contact your local fire department on a non-emergency telephone number and explain your special needs.

- ✓ Your local fire department will be able to help you with your escape plan and may also be able to perform a home fire safety inspection, as well as offer suggestions about smoke alarm placement and maintenance.
- **Ask emergency providers to keep your special needs information on file.**



Modern 911 Dispatcher's center.

Emergency Evacuation Planning

- ✓ Emergency action plans are required describe the routes to use and procedures to be followed by employees. Also procedures for accounting for all evacuated employees must be part of the plan. The written plan must be available for employee review.
- ✓ Where needed, special procedures for helping physically impaired employees must be addressed in the plan; also, the plan must include procedures for those employees who must remain behind temporarily to shut down critical plant equipment before they evacuate.
- ✓ The preferred means of alerting employees to a fire emergency must be part of the plan and an employee alarm system must be available throughout the workplace complex and must be used for emergency alerting for evacuation. The alarm system may be voice communication or sound signals such as bells, whistles or horns. Employees must know the evacuation signal.
- ✓ Training of all employees in what is to be done in an emergency is required. Employers must review the plan with newly assigned employees so they know correct actions in an emergency and with all employees when the plan is changed.



1910.38(b)(3)

"Housekeeping." The employer shall control accumulations of flammable and combustible waste materials and residues so that they do not contribute to a fire emergency. The housekeeping procedures shall be included in the written fire prevention plan.

1910.38(b)(4)

"Training."

1910.38(b)(4)(i)

The employer shall apprise employees of the fire hazards of the materials and processes to which they are exposed.

..1910.38(b)(4)(ii)



- **Check labels on lamps and use the right size bulb. Check the label on your fuse box and be sure you use the right size fuses.**
- **Fix electrical problems right away. If fuses blow often, circuit breakers trip often, switches get hot or people are shocked, something is wrong.**
- **Cover unused outlets with plastic plugs.**
- **If a cord has 3-prongs, use it properly. Don't remove the extra prong. The third prong is there because the appliance must be grounded to prevent electrical shocks.**
- **Take cover during a thunder storm. If you are indoors, stay away from open windows and doors and use the telephone only in an emergency. If you are outdoors stay in your car and away from water, trees, and metal objects. Avoid low areas that might flood in a heavy rain.**
- **Do not overhaul outlets. Extension cords shouldn't be used as permanent fixtures in home rebuilding.**

Fire Prevention Plan

- ✓ Employers need to implement a written fire prevention plan to complement the fire evacuation plan to minimize the frequency of evacuation. Stopping unwanted fires from occurring is the most efficient way to handle them. The written plan shall be available for employee review.
- ✓ Housekeeping procedures for storage and cleanup of flammable materials and flammable waste must be included in the plan. Recycling of flammable waste such as paper is encouraged; however, handling and packaging procedures must be included in the plan.
- ✓ Procedures for controlling workplace ignition sources such as smoking, welding and burning must be addressed in the plan. Heat producing equipment such as burners, heat exchangers, boilers, ovens, stoves, fryers, etc., must be properly maintained and kept clean of accumulations of flammable residues; flammables are not to be stored close to these pieces of equipment.
- ✓ All employees are to be apprised of the potential fire hazards of their job and the procedures called for in the employer's fire prevention plan. The plan shall be reviewed with all new employees when they begin their job and with all employees when the plan is changed.

1910.38(b)

"Fire prevention plan" -

1910.38(b)(1)

"Scope and application." This paragraph (b) applies to all fire prevention plans required by a particular OSHA standard. The fire prevention plan shall be in writing, except as provided in the last sentence of paragraph (b)(4)(ii) of this section.

..1910.38(b)(2)

1910.38(b)(2)

"Elements." The following elements, at a minimum, shall be included in the fire prevention plan:

1910.38(b)(2)(i)

A list of the major workplace fire hazards and their proper handling and storage procedures, potential ignition sources (such as welding, smoking and others) and their control procedures, and the type of fire protection equipment or systems which can control a fire involving them;

1910.38(b)(2)(ii)

Names or regular job titles of those personnel responsible for maintenance of equipment and systems installed to prevent or control ignitions or fires; and

1910.38(b)(2)(iii)

Names or regular job titles of those personnel responsible for control of fuel source hazards.





Notice the blocked access to the Fire Line Stand Pipe (Riser) and poor housekeeping. Depending upon the Fire Code, the Riser needs to be inspected at least annually or more frequently depending on the stock or processes in the facility. You will find a yellow inspection tag allow will spare sprinkler parts along side or attached to the Riser.



FIRE EVACUATION PLAN (example)

DATE OF EVALUATION: February 15, 2002	DATE LAST EVALUATED: N/A
--	---------------------------------

TOWN OF SUNFLOWER, PUBLIC WORKS DEPARTMENT

DEPARTMENT: Water Department	TELEPHONE: 474-5222 Ext 289
ADDRESS/LOCATION: 69 N. Beeline Hwy	NAME OF DEPARTMENT SUPERINTENDENT: Frank Jones
Actions are required by: 29 CFR 1910.1200, 29 CFR 1910.138 -146 and Town of Sunflower	NAME OF HAZARD COMMUNICATION PROGRAM MONITOR: Frank Jones

POTENTIAL HAZARDS FIRE

FIRE: If smoke or fire is detected, remove any person that shall require assistance from immediate danger. Close doors to confine and to prevent the fire from spreading to other areas. Send for help. Call Sunflower Fire Department or **911**, any employee can call the Fire Department, or pull Fire Alarm.

Combat small, contained fires with portable fire extinguishers- **IF SAFE TO DO SO!** Exit building, with the last person to leave to close the door.

All personnel will evacuate to the north parking lot Assembly Area (North of City Hall).

Management shall authorize any occupant to sound the alarm and notify the Fire Department upon the discovery of fire or smoke.

CONTROLS

(Existing or Recommended Protective Equipment, Engineering or Administrative Controls)

Every Department/Building/Section in the Town of Sunflower is required by 29 CFR 1910.38 and the Town Fire Safety Program to include evacuation procedures, rules for fire extinguishers, fire suppression, and building fire exit inspections. Exercising the plan with Fire Department input and cooperation is essential, especially the scheduling of periodic fire exit drills. It is your Section Supervisor's responsibility to develop a fire evacuation plan and to conduct fire exit drills.

The purpose of fire exit drills is to ensure a safe and orderly exit from the building. In the event of a fire, speed is secondary to proper order and control. An initial fire drill shall be held on approval of this plan by the Fire Department. Additional drills will be held every (6) six months. The Fire Department will assist and participate in the first scheduled fire exit drill and will assist the Section Supervisor in preparing a fire inspection and plan of action for fire evacuation drills.

Portable fire extinguishers are provided throughout the Water Dept. building for extinguishing small controllable fires. Fire extinguisher use training is available. All employees must be familiar with the fire evacuation plan, exits, and assigned refuge area (North Parking Lot)

Management shall insure that building fire protection and emergency equipment is maintained. Management shall maintain a list of all disabled personnel known to be occupants of the building. The Safety Representative will insure that Material Safety Data Sheets and the Chemical Inventory are made available to the Fire Department for emergency use.

Surveyed By: Jesse David	Reviewed By: Jack Kolie
---------------------------------	--------------------------------



COMBUSTIBLE LIQUID: Combustible liquids have a flash point of 100°F (38°C) or higher. Non-liquid materials, such as wood or paper, are classified as ordinary combustibles.

Fire Suppression Systems

- ✓ Properly designed and installed fixed fire suppression systems enhance fire safety in the workplace. Automatic sprinkler systems throughout the workplace are among the most reliable fire fighting means. The fire sprinkler system detects the fire, sounds an alarm and puts the water where the fire and heat are located.
- ✓ Automatic fire suppression systems require proper maintenance to keep them in serviceable condition. When it is necessary to take a fire suppression system out of service while business continues, the employer must temporarily substitute a fire watch of trained employees standing by to respond quickly to any fire emergency in the normally protected area. The fire watch must interface with the employers' fire prevention plan and emergency action plan.
- ✓ Signs must be posted about areas protected by total flooding fire suppression systems which use agents that are a serious health hazard such as carbon dioxide, Halon 1211, etc. Such automatic systems must be equipped with area pre-discharge alarm systems to warn employees of the impending discharge of the system and allow time to evacuate the area. There must be an emergency action plan to provide for the safe evacuation of employees from within the protected area. Such plans are to be part of the overall evacuation plan for the workplace facility.



Double Check Backflow Assembly (Notice chain).



Halon Systems. These are almost completely removed because of the suffocation danger and other damage to frail humans. If fire wasn't enough.



Reduced Pressure Backflow Assembly. A device to prevent contaminants from backflowing into the public water system.

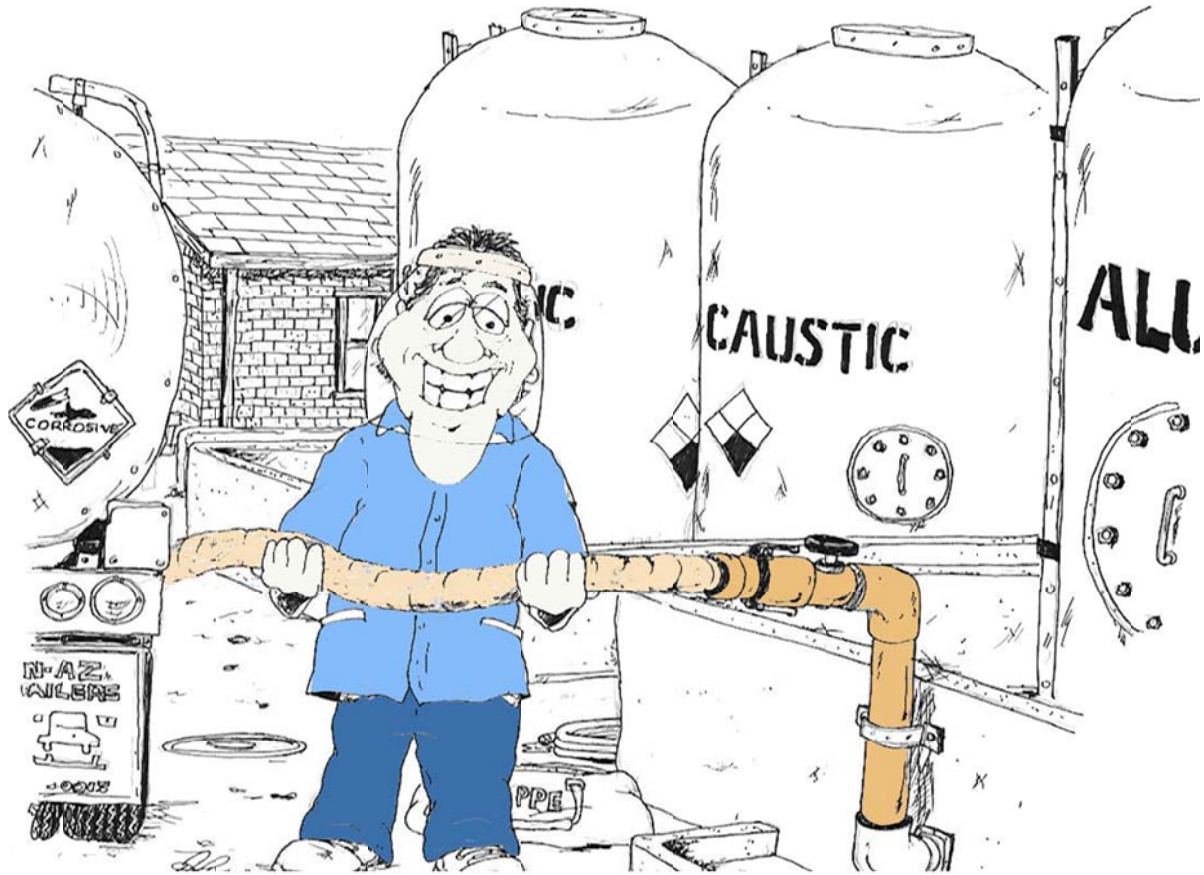

Storage Site

The entire storage site shall be kept free from accumulation of unnecessary combustible materials. Weeds and grass shall be kept down and a regular procedure provided for the periodic cleanup of the entire area. When there is a danger of an underground fire, that land shall not be used for combustible or flammable storage.

Method of piling shall be solid wherever possible and in orderly and regular piles. No combustible material shall be stored outdoors within 10 feet of a building or structure.

Portable fire extinguishing equipment, suitable for the fire hazard involved, shall be provided at convenient, conspicuously accessible locations in the yard area. Portable fire extinguishers, rated not less than 2A, shall be placed so that maximum travel distance to the nearest unit shall not exceed 100 feet.

Exposing an Invisible Killer: *Carbon Monoxide*

Each year in America, carbon monoxide (**CO**) poisoning claims more than 200 lives and sends another 10,000 people to hospital emergency rooms for treatment.

UNDERSTANDING THE RISK

What is carbon monoxide?

- Carbon monoxide is an odorless, colorless and toxic gas. Because it is impossible to see, taste or smell the toxic fumes, CO can kill you before you are aware it is in your home. At lower levels of exposure, CO causes mild effects that are often mistaken for the flu. These symptoms include headaches, dizziness, disorientation, nausea and fatigue. The effects of CO exposure can vary greatly from person to person depending on age, overall health and the concentration and length of exposure.

Where does carbon monoxide come from?

- CO gas can come from several sources: gas-fired appliances, charcoal grills, wood-burning furnaces or fireplaces and motor vehicles.

Who is at risk?

- Everyone is at risk for CO poisoning. Medical experts believe that unborn babies, infants, children, senior citizens and people with heart or lung problems are at even greater risk for CO poisoning.

WHAT ACTIONS DO I TAKE IF MY CARBON MONOXIDE ALARM GOES OFF?

What you need to do if your carbon monoxide alarm goes off depends on whether anyone is feeling ill or not.

If no one is feeling ill:

1. Silence the alarm.
2. Turn off all appliances and sources of combustion (i.e. furnace and fireplace).
3. Ventilate the house with fresh air by opening doors and windows.
4. Call a qualified professional to investigate the source of the possible CO buildup.

If illness is a factor:

1. Evacuate all occupants immediately.
2. Determine how many occupants are ill and determine their symptoms.
3. Call your local emergency number and when relaying information to the dispatcher, include the number of people feeling ill.
4. Do not re-enter the home without the approval of a fire department representative.
5. Call a qualified professional to repair the source of the CO.

PROTECT YOURSELF AND YOUR FAMILY FROM CO POISONING

- Install at least one UL (Underwriters Laboratories) listed carbon monoxide alarm with an audible warning signal near the sleeping areas and outside individual bedrooms. Carbon monoxide alarms measure levels of CO over time and are designed to sound an alarm before an average, healthy adult would experience symptoms. It is very possible that you may not be experiencing symptoms when you hear the alarm. This does not mean that CO is not present.
- Have a qualified professional check all fuel burning appliances, furnaces, venting and chimney systems at least once a year.
- Never use your range or oven to help heat your home and never use a charcoal grill or hibachi in your home or garage.
- Never keep a car running in a garage. Even if the garage doors are open, normal circulation will not provide enough fresh air to reliably prevent a dangerous buildup of CO.

When purchasing an existing home, have a qualified technician evaluate the integrity of the heating and cooking systems, as well as the sealed spaces between the garage and house. The presence of a carbon monoxide alarm in your home can save your life in the event of CO buildup.



What Saves Lives

Fire Safety Tips

In the event of a fire, remember time is the biggest enemy and every second counts!

Escape first, and then call for help. Develop a home fire escape plan and designate a meeting place outside. Make sure everyone in the family knows two ways to escape from every room. Practice feeling your way out with your eyes closed. Never stand up in a fire, always crawl low under the smoke and try to keep your mouth covered. Never return to a burning building for any reason; it may cost you your life.

Finally, having a working smoke alarm dramatically increases your chances of surviving a fire.

And remember to practice a home escape plan frequently with your family.

Source: National Fire Protection Association 1998 Fire Loss in the U.S. and Fire in the United States 1987-1996 11th Edition

INSTALL AND MAINTAIN SMOKE ALARMS

Working smoke alarms installed on every level of your home dramatically increase your chances of survival.

- ✓ People with physical limitations should be aware of special fire safety devices that are available, such as smoke alarms with a vibrating pad or flashing light for the deaf and hard of hearing. In addition, smoke alarms with a strobe light outside the house can catch the attention of neighbors or others who might pass by.
- ✓ Smoke alarm batteries need to be tested every month and changed at least once a year. If you can't reach the test button on your smoke alarm, ask someone to inspect it for you.
- ✓ A working smoke alarm dramatically increases a person's chance of surviving a fire.
- ✓ Approximately 88 percent of U.S. homes have at least one smoke alarm. However, these alarms are not always properly maintained and as a result might not work in an emergency. There has been a disturbing increase over the last ten years in the number of fires that occur in homes with non-functioning alarms.
- ✓ It is estimated that over 40 percent of residential fires and three-fifths of residential fatalities occur in homes with no smoke alarms.

Residential sprinklers have become more cost effective for homes. Currently, few homes are protected by them.



SAFETY ZONE: An area cleared of flammable material used for escape in the event the line is outflanked or in case a spot fire causes fuels outside the control line to render the line unsafe. In firing operations, crews progress so as to maintain a safety zone close at hand allowing the fuels inside the control line to be consumed before going ahead. Safety zones may also be constructed as integral parts of fuel breaks; they are greatly enlarged areas which can be used with relative safety by firefighters and their equipment in the event of blowup in the vicinity.

Smoke Detectors

Properly installed and maintained smoke detectors provide early warning of a fire.

When there is a fire in your home, you are much more likely to survive when you have working smoke detectors.

Keep your smoke detectors properly maintained. Test them at least once every month to make sure they work.

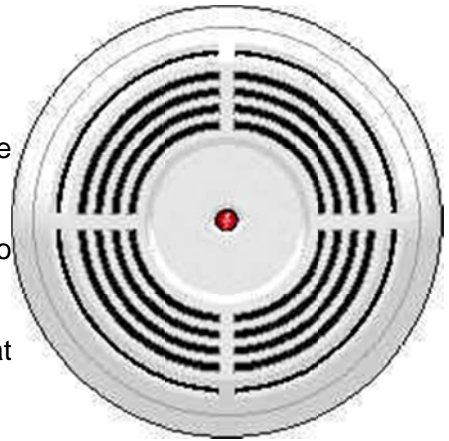

Time is crucial. When your smoke detector sounds, you may only have a minute or two to escape.

SMOKE DETECTOR Q & A

How effective are smoke detectors?

Residential fire deaths have decreased steadily as the number of homes with smoke detectors increased.

Reports from the National Fire Protection Association on residential fire deaths show that people have nearly a 50 percent better chance of surviving a fire if their home has the recommended number of smoke detectors.

In the event of a fire, properly installed and maintained smoke alarms will provide an early warning signal to your household. This alarm could save your own life and those of your loved ones by providing the chance to escape.

How many detectors should I have?

The average sized home or apartment needs more than one smoke detector. The exact number depends on the number of levels in the home and the number of bedrooms. National fire safety standards recommend a minimum of one detector on each level of the home, one detector outside the bedroom area, and one in each bedroom.

Where smoke detectors should be installed?

Install smoke alarms on every level of your home, including the basement. Many fatal fires begin late at night or in the early morning. For extra safety, install smoke alarms both inside and outside the sleeping area.

The detector that is placed outside of the bedroom area should be installed near enough to be heard at night through a closed bedroom door.

Also, smoke alarms should be installed on the ceiling or 6 to 8 inches below the ceiling on side walls. Since smoke and many deadly gases rise, installing your smoke alarms at the proper level will provide you with the earliest warning possible. Always follow the manufacturer's installation instructions.

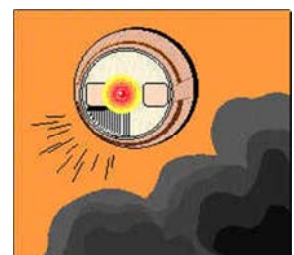

Is there more than one type of smoke detector, and what is the difference?

There are two types of smoke detectors for homes. One type is called an ionization detector because it monitors *ions*, or electrically charged particles. Smoke particles entering the sensing chamber change the electrical balance of the air. The detector's horn will sound when the change in electrical balance reaches a preset level.

The other type of detector is called photoelectric because its sensing chamber uses a beam of light and a light sensor. Smoke particles entering the chamber change the amount of light that reaches the light sensor. The detector sounds when the smoke density reaches a preset level.

There is also a combination detector that incorporates both photoelectric and ionization sensors in a single unit.

Is one type better than the other?

The ionization detector responds faster to small smoke particles, while the photoelectric responds faster to large smoke particles. Usually fast-flaming fires produce more small smoke particles and smoldering fires produce more large particles.

Thus, the response time of the two types of detectors will vary, depending on the mix of small and large smoke particles in the fire. Both types, however, activate in either type of fire situation.

What is more important, the type of detector or the number?

The number and the positioning of detectors is more important than the type. Installing several smoke detectors of each type or using combination detectors will provide better coverage for long-term smoldering or fast flaming fires. The most important thing however, is to install enough detectors in the proper locations regardless of type.

When should I replace my smoke detector?

Smoke detectors that are 10 years old are near the end of their service life and should be replaced. A smoke detector constantly monitors the air 24 hours a day. At the end of 10 years, it has gone through over 3.5 million monitoring cycles. After this much use, components may become less reliable. This means that as the detector gets older, the potential of failing to detect a fire increases.

Replacing them after 10 years reduces this possibility.

My detectors are wired into my electrical system. Do I need to replace them as often as battery-operated detectors?

Yes. Both types of detectors are equally affected by age.

What about changing batteries?

The detector will sound a short beep about once every minute, when a battery reaches the end of its service life. When this low battery warning is heard the batteries should be replaced. Always use new batteries when replacing old ones.

The most effective way to insure that you always have operable batteries in your smoke detectors is to change them twice a year at the same time you reset your clocks for Daylight Saving Time.

My detector goes off when I cook. How can I stop this?

If the detector activates when smoke from cooking is unusually heavy, you can silence the detector by fanning it with a newspaper to clear the smoke from the chamber. Don't remove the batteries.

This is a bad idea as you may forget to replace them. If a detector is being activated by normal cooking activity, repositioning the detector to a location further away from the cooking area is one way to resolve the problem. If repositioning the detector is not feasible, then it could be replaced with a detector which has a button to silence it for a few minutes, or with a photoelectric type if it's a ionization detector.

How can I test my detector?

Every smoke detector comes with a test button. Detectors should be tested regularly, at least once a month.

Should I use real smoke to test my detectors?

NO. The burning object used to generate the real smoke could cause a real fire.



How important is it to clean my detectors?

It is very important. Dust accumulation and cooking residue can significantly increase the time it takes a detector to respond to a fire. Fortunately, cleaning is easy. Simply vacuum the detector to remove dust and residue from the openings.

I've heard about fires where smoke detectors didn't work. Why?

The most common reason that smoke detectors fail to operate is due to people removing the batteries. This is often done to silence the detector because of a nuisance alarm or to stop the low battery warning beep and then forgetting to replace them. The only time batteries should be removed from a smoke detector is when you replace them.



**WATCH FOR SLIP
HAZARDS!!**



Right-to-Know Hazard Communication and Fire Section

Employees have a right to know about chemical hazards in their workplace. With the help of the Hazard Communication Standard, they can protect themselves from chemical injuries and hazards.

Employees should practice these safety rules every day on the job:

- ✓ Know where to find the company's written HazCom program and MSDSs.
- ✓ Identify hazards before starting a job.
- ✓ Use correct personal protective equipment when handling hazardous substances.
- ✓ Practice sensible, safe work habits; follow warnings and instructions.
- ✓ Respect all precautions-don't take chances.
- ✓ Ask the supervisor when in doubt.
- ✓ Know in advance what could go wrong and what to do about it.
- ✓ Know how and where to get help.

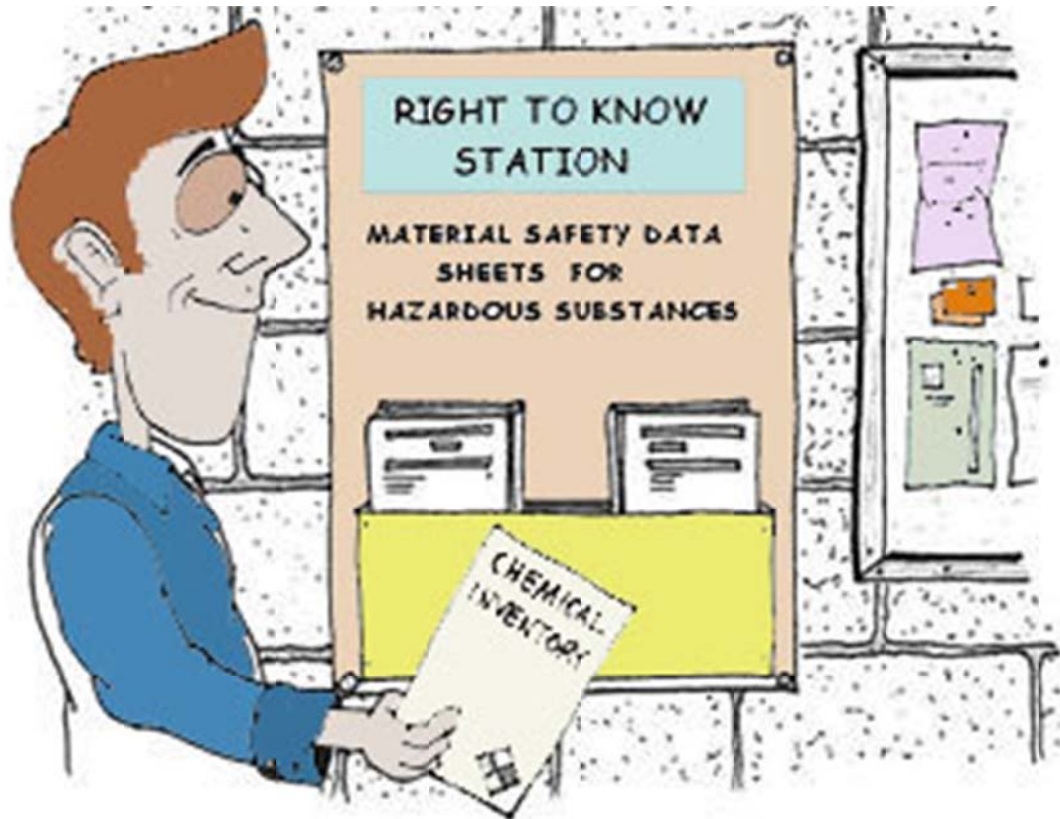

Different Types of Chemical Hazards

Chemicals cause health hazards if they are:

- ✓ **Target organ chemicals**—they injure specific organs in your body.
- ✓ **Toxic**—cause illness or death. Toxic chemicals are determined on the basis of tests on laboratory animals that are exposed to a given chemical through either inhalation, ingestion, or skin absorption.
- ✓ **Corrosive**—can destroy your skin or eyes.
- ✓ **Irritants**—cause reversible inflammation when they make contact with living tissue.
- ✓ **Carcinogens**—have been known to cause cancer or have the potential of causing cancer in humans.
- ✓ **Sensitizers**—can cause an allergic reaction on subsequent repeated exposures.
- ✓ **Neurotoxins**—produce toxic effects primarily on the central nervous system.
- ✓ **Nephrotoxins**—Produce toxic effects on kidneys.
- ✓ **Reproductive toxins**—have the potential to adversely affect the reproductive system.
- ✓ **Hepatotoxins**—can adversely affect the liver.
- ✓ **Lung hazards**—can irritate or damage pulmonary tissue.
- ✓ **Skin hazards**—can affect the dermal layer of the body, resulting in rashes and irritation.
- ✓ **Eye hazards**—can adversely affect the eye or diminish the visual capacity of a human.
- ✓ **Blood system hazards**—caused by chemicals that decrease the hemoglobin function; depriving of oxygen. Chemicals that present physical hazards and are covered by the Hazard Communication Standard include combustible liquids, flammable materials, all compressed gases, explosives, organic peroxides, oxidizers, pyrophoric materials, unstable materials, and water-reactive materials.
- ✓ **Fire hazards**—chemicals that have the potential for creating a fire or aiding an ongoing fire.

These materials are flammables, combustibles, oxidizers, pyrophoric materials, and organic peroxides.

- ✓ **Flammables**—catch fire quickly.
- ✓ **Oxidizers**—capable of initiating or promoting a fire in other compounds by the release of oxygen or other gases.
- ✓ **Pyrophoric materials**—can be ignited as a result of contact with oxygen in the absence of an ignition source at temperature below 130°F.
- ✓ **Organic peroxides**—contain both fuel, in the form of carbon, and excess oxygen, and thus can pose a severe fire hazard.
- ✓ **Compressed gases**—all compressed gases pose a physical hazard.
- ✓ **Explosive materials**—can be decomposed in a violent chemical reaction with the production of heat, pressure, and large quantities of gas.
- ✓ **Unstable materials**—certain compounds in their pure form can undergo vigorous decomposition or polymerization under moderate conditions of shock, pressure, or temperature.
- ✓ **Water-reactive compounds**—can react vigorously with water to produce a toxic or flammable gas.



Battery Separation, Below is the effects of water and Lithium a small explosion.



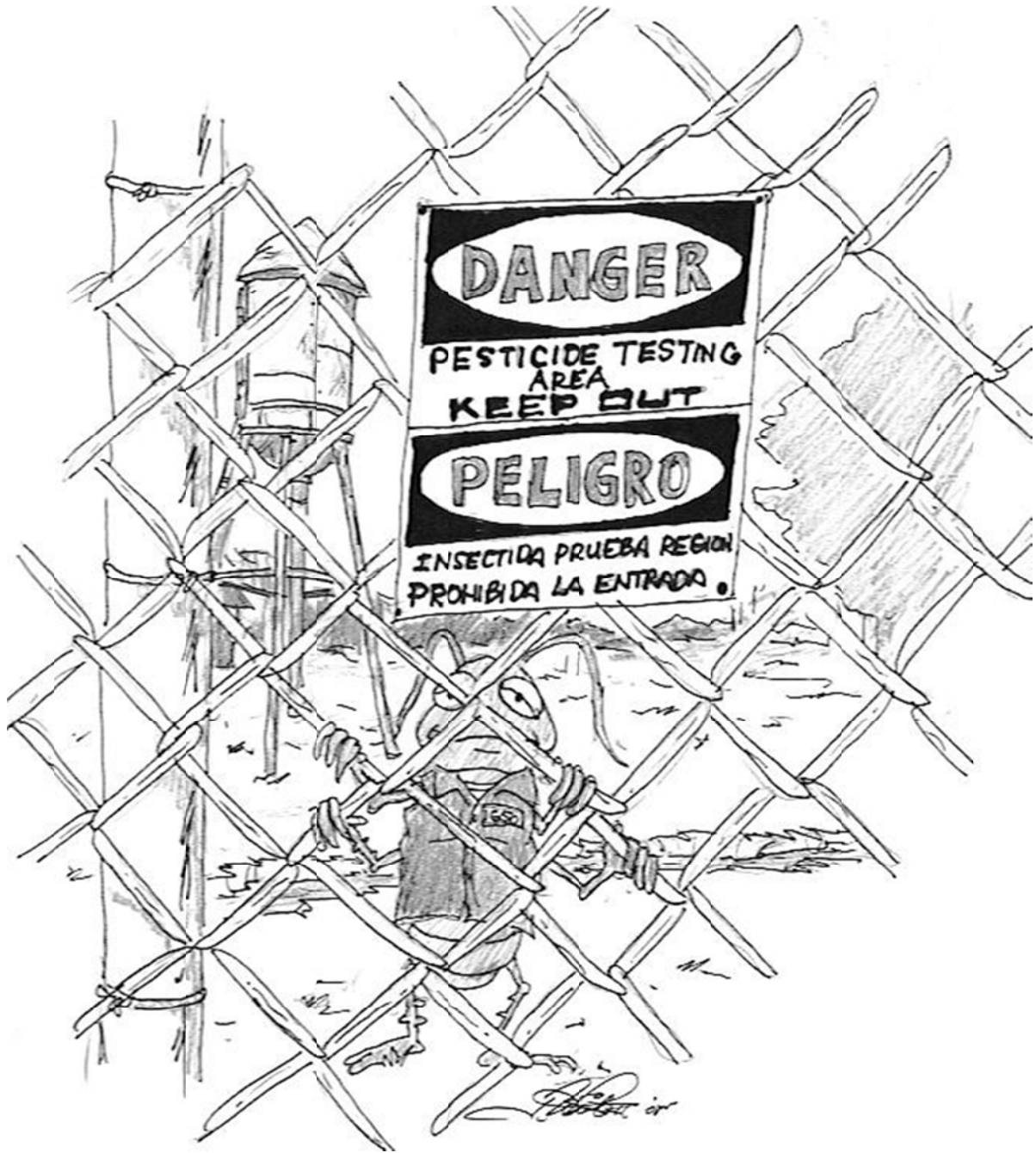

Identifying Hazardous and Flammable Chemicals

Chemical manufacturers have to let users know about hazards. They do this by providing for each product a container label, which gives a quick overview of the chemical, and an MSDS, which offers more complete information.

Label Information

Hazardous chemical containers are labeled by the manufacturer. The label format may differ from company to company, but all labels must contain the same information. This makes it easy to determine at a glance about a chemical's possible hazards and the basic steps that employees must take to protect themselves.

The label may use words or symbols to tell you:

- ✓ The chemical's identity and its components (unless they're part of the manufacturer's trade secrets, which do not have to be revealed)
- ✓ The name and address of the company that made or imported the chemical
- ✓ Specific hazard warnings, such as physical or health hazards Labels may also include:
 - ✓ Precautionary measures, such as basic protective clothing, equipment, and procedures to work safely
 - ✓ Proper handling and storage instructions
 - ✓ First-aid instructions
 - ✓ Special instructions concerning children

MSDS Information

Each company should have on file an MSDS for every chemical and hazardous product in the workplace. MSDSs describe everything an employee needs to know about the chemical.

Employees must read the MSDS before starting a job to know what they're working with and how to handle it safely. Though individual MSDSs may give a different amount of information, they all contain similar types of information.

Grounding and Bonding

Grounding and Bonding of flammable chemicals is important to prevent electric shock or a buildup of static electricity that could cause sparks and result in ignition of flammable vapors. Cables that are about ten feet long and have a "**banana**" plug that fits the outlets should be readily available.

If grounding is used in the facility, the supervisor or safety designate should be certain, that the connections are sound, the cable is adequate, and the path to ground is valid. Connections to water pipes, metal shelving, glass drying racks, and the like for grounding do not always guarantee a clear path to ground.

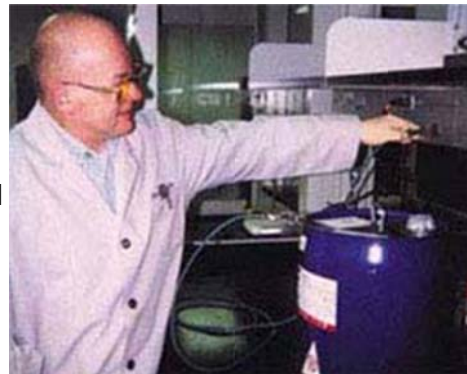

MSDSs explain:

- ✓ **Identity of the chemical.** This includes its chemical and common names, manufacturer, etc. If the chemical is a mixture, each ingredient in the mix will be listed along with its hazards. The only time the components won't be covered is when they're a trade secret, but the MSDS will still tell about the hazards and required safety measures.
- ✓ **Physical and chemical characteristics.** The MSDS provides information such as the chemical's boiling point, vapor pressure, vapor density, melting point, evaporation point, evaporation rate, water solubility, flash point, and appearance and odor under normal conditions.
- ✓ **Physical hazards.** This covers such possible hazards as fire and explosion and what means should be used to prevent and to combat them.
- ✓ **Health hazards.** For example, the MSDS will reveal whether the chemical is believed to be a carcinogen and whether the hazards are acute (**short-term**) or chronic (**long-term**). It will give any permissible exposure limits set by OSHA or other agencies.
- ✓ **Signs and symptoms of exposure.** The chemical could cause eye irritation, nausea, dizziness, headaches, skin rashes, or aggravate existing medical conditions.
- ✓ **How the chemical enters the body.** It's important to know how exposure occurs: swallowing, inhaling, or contacting skin or eyes.
- ✓ **Reactivity.** The MSDS reports on the substance's stability as well as chemicals and situations that could make the substance unstable.
- ✓ **Protective equipment.** Any PPE such as respirators, gloves, goggles, etc. that are recommended to prevent exposure will be listed, along with ventilation requirements.
- ✓ **Spills, leaks, and disposal.** If the substance is accidentally released, the MSDS explains how to handle such an incident and dispose of the substance properly.
- ✓ **Handling and storage.** The proper ways of handling and storing the substance are covered by the MSDS.
- ✓ **Other.** The MSDS may also go into other topics related to the substance's hazards, such as toxicity to fish if spilled, transport requirements, etc.

The **MSDS** is every worker's guide to safe handling of hazardous substances. An individual chemical's hazards determine exactly what information the MSDS contains.

However, it always contains the information needed to avoid accidents and illness when handling that substance. Stress to employees the importance of reading the MSDS before starting a job.



MSDS Terminology

The Hazard Communication Standard requires employees to understand chemical hazards, labels, and MSDSs and to use them on the job. Before starting jobs involving possible exposure to hazardous substances, employees must read MSDSs to know what they're working with and procedures for safe handling.

Hundreds, perhaps thousands, of terms could be included in a listing like the one provided in this session. The list of terms and definitions included in this session is not comprehensive or all-inclusive.

The intent is to provide users with a brief list of some of the terms that may appear in common MSDSs. Additional terms specific to the substances your company uses or keeps on-site should be added to the list.

The list of terms and definitions included in this session has been divided into three categories:

- ✓ **Health hazards**
- ✓ **Physical hazards**
- ✓ **Hazardous limits.**

1. Where are labels used? (On the container of every hazardous chemical in the workplace. Hazardous chemicals can pose a danger to people or the environment.)



2. What does a label tell you? (It lists the chemical's identity, who made it, its hazards, and protections against those hazards.)

3. When should employees read the label for a hazardous chemical? (Before starting the job every time that chemical is used—its hazards or protections could change or an employee could forget or confuse it with other chemicals.)

The Hazard Communication Standard (29 CFR 1910.1200) specifically requires every hazardous chemical container to have a label. Labels are part of the company's Hazard Communication Program, which gives employees the Right to Know about the chemical hazards they face on the job.



Label Information

Hazardous chemical containers are labeled by the manufacturer. The label format may differ from company to company, but all labels must contain the same information. This makes it easy to determine at a glance about a chemical's possible hazards and the basic steps that employees must take to protect themselves.

Colors, Number Codes

Color- and number-coded label systems have been developed by the National Fire Protection Association (NFPA) and other organizations.

Colors represent the kind of hazard:

- Red** means a fire hazard
- Yellow** is a reactivity hazard
- Blue** is a health hazard.

Numbers show the degree of hazard:

- 0** = minimal hazard
- 1** = slight hazard
- 2** = moderate hazard
- 3** = serious hazard
- 4** = severe hazard.

For example, a Blue 4 would mean that very short exposure to this substance could cause death or major injury even if the person received prompt medical treatment.

A Blue 2 signifies less risk; exposure could problems after heavy or continued exposure.

A Red 4 indicates an extremely flammable substance; a material marked Red 1, though not easily ignitable, will burn as a fuel.

A Yellow 4 marking means the substance could detonate or explode or react at normal pressure and room temperature.

Yellow 2 indicates a substance that is unstable or may react with water.

The white part of the label is handled differently by different systems.



HMIS LABEL

HEALTH HAZARD

- 4 - Deadly
- 3 - Extreme Danger
- 2 - Hazardous
- 1 - Slightly Hazardous
- 0 - Normal Materials
- * Chronic Hazard

REACTIVITY HAZARD

- 4 - May Detonate
- 3 - Shock & Heat May Detonate
- 2 - Violent Chemical Change
- 1 - Unstable if Heated
- 0 - Stable



FIRE HAZARD

- 4 - Very Flammable
- 3 - Readily Ignitable
- 2 - Ignited with Heat
- 1 - Combustible
- 0 - Will not Burn

PERSONAL PROTECTIVE EQUIPMENT RECOMMENDATIONS

NFPA-type labels list specific hazards in the white area:

OX = oxidizer

acid = acid

alk = alkali

co = corrosive

[W with a line through it] = Use no water

[Symbol] = Radioactive

Color bar-type labels use a letter in the white bar to tell which personal protective equipment to use. For example,

A = goggles

B = goggles and gloves

C = face mask, gloves, apron.

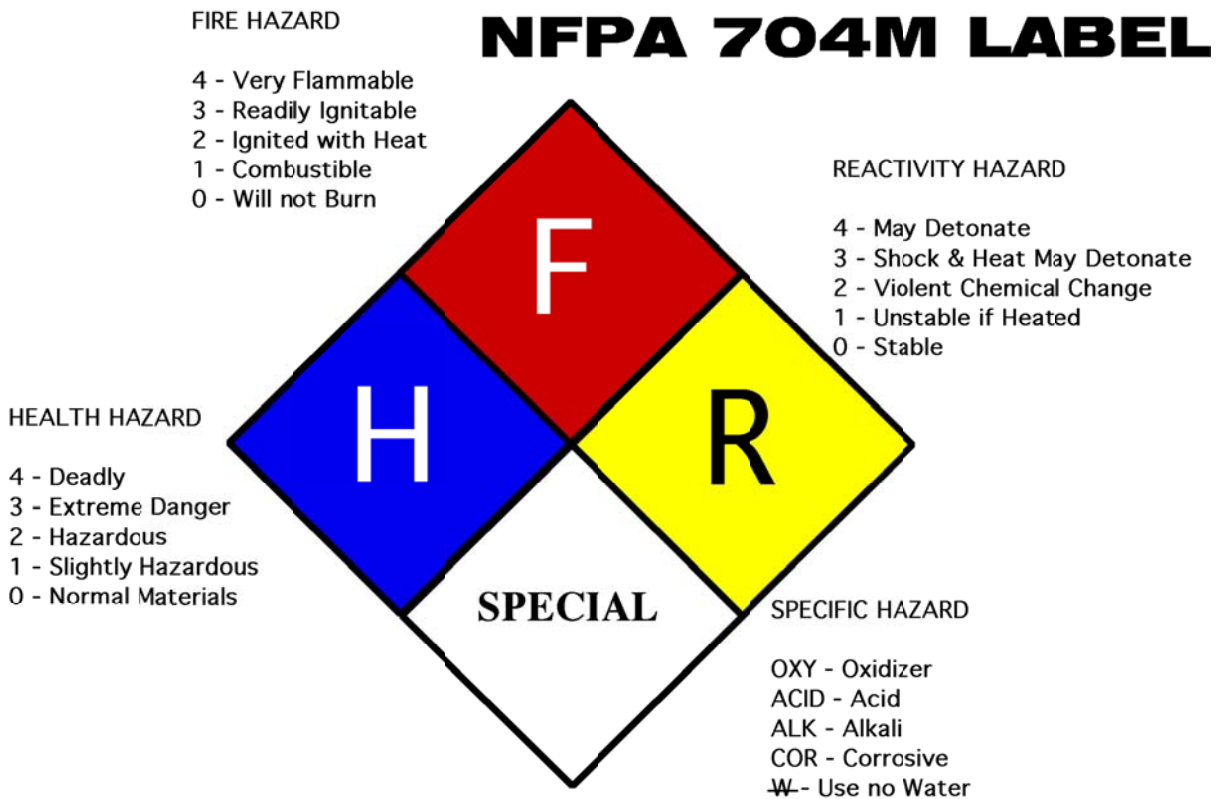

High-Rise Safety

Recent fatal fires in high-rise structures have prompted Americans to rethink fire safety. A key to fire safety for those who live and work in these special structures is to practice specific high-rise fire safety and prevention behaviors.

BE PREPARED FOR A HIGH-RISE FIRE EMERGENCY

- Never lock fire exits or doorways, halls or stairways. Fire doors provide a way out during the fire and slow the spread of fire and smoke. Never prop stairway or other fire doors open.
- Learn your buildings evacuation plans. Make sure everyone knows what to do if the fire alarm sounds. Plan and practice your escape plan together.
- Be sure your building manager posts evacuation plans in high traffic areas, such as lobbies.
- Learn the sound of your building's fire alarm and post emergency numbers near all telephones.
- Know who is responsible for maintaining the fire safety systems. Make sure nothing blocks these devices and promptly report any sign of damage or malfunction to the building management.

DO NOT PANIC IN THE EVENT OF A HIGH-RISE FIRE EMERGENCY

- Do not assume anyone else has already called the fire department.
- Immediately call your local emergency number. Early notification of the fire department is important. The dispatcher will ask questions regarding the emergency. Stay calm and give the dispatcher the information they request.

IF THE DOOR IS WARM TO THE TOUCH

Before you try to leave your apartment or office, feel the door with the back of your hand. If the door feels warm to the touch, do not attempt to open it. Stay in your apartment or office.

- Stuff the cracks around the door with towels, rags, bedding or tape and cover vents to keep smoke out.
- If there is a phone in the room where you are trapped, call the fire department again to tell them exactly where you are located. Do this even if you can see fire apparatus on the street below.
- Wait at a window and signal for help with a flashlight or by waving a sheet.
- If possible, open the window at the top and bottom, but do not break it, you may need to close the window if smoke rushes in.
- Be patient. Rescuing all the occupants of a high-rise building can take several hours.

IF THE DOOR IS NOT WARM TO THE TOUCH

- If you do attempt to open the door, brace your body against the door while staying low to the floor and slowly open it a crack. What you are doing is checking for the presence of smoke or fire in the hallway.
- If there is no smoke in the hallway or stairwells follow your building's evacuation plan.
- If you don't hear the building's fire alarm, pull the nearest fire alarm "**pull station**" while exiting the floor.
- If you encounter smoke or flames on your way out, immediately return to your apartment or office.

Curious Kids Set Fires: Teaching Children Fire Safety

Every day Americans experience the tragedy of fire. Each year more than 4,000 Americans die in fires and more than 25,000 are injured. Figures show that each year about 300 people are killed and \$280 million in property is destroyed in fires attributed to children playing with fire.

Curious Kids Set Fires

Children under five are curious about fire. Often what begins as a natural exploration of the unknown can lead to tragedy.

- Children of all ages set over 100,000 fires annually. Approximately 20,000 of those fires are set in homes.
- Children make up 20% of all fire deaths.
- Over 30% of the fires that kill children are set by children playing with fire.
- At home, children usually play with fire in bedrooms, in closets and under beds. These are "secret" places where there are a lot of things that catch fire easily.
- Too often, child firesetters are not given proper guidance and supervision by parents and teachers. Consequently, they repeat their firesetting behavior.

Practice Fire Safety in Your Home

- Supervise young children closely. Do not leave them alone even for short periods of time.
- Keep matches and lighters in a secured drawer or cabinet.
- Have your children tell you when they find matches and lighters.
- Check under beds and in closets for burned matches, evidence your child may be playing with fire.
- Develop a home fire escape plan, practice it with your children and designate a meeting place outside.
- Take the mystery out of fire play by teaching children that fire is a tool, not a toy.
- Teach children the nature of fire. It is **FAST, HOT, DARK and DEADLY!**
- Teach children not to hide from firefighters, but to get out quickly and call for help from another location.
- Show children how to crawl low on the floor, below the smoke, to get out of the house and stay out in the case of fire.
- Demonstrate how to stop, drop to the ground and roll if their clothes catch fire.
- Install smoke alarms on every level in your home.
- Familiarize children with the sound of your smoke alarm.
- Test the smoke alarm each month and replace the battery at least once a year.
- Replace the smoke alarm every ten years, or as recommended by the manufacturer.

Finally, having a working smoke alarm dramatically increases your chances of surviving a fire. And remember to practice a home escape plan frequently with your family.

Rural Fire Safety and Prevention

A move from an urban center to a suburb or rural area requires you to rethink fire safety. First, you must be aware of special fire hazards near wooded areas. Second, geographic location may create longer response times for fire and rescue services.

Fire Facts about Rural Living

- Once a fire starts outdoors in a rural area, it is often hard to control. Wildland firefighters are trained to protect natural resources, not homes and buildings.
- Many homes are located far from fire stations. The result is longer emergency response times. Within a matter of minutes, an entire home may be destroyed by fire.
- Limited water supply in rural areas can make fire suppression difficult.
- Homes may be secluded and surrounded by woods, dense brush and combustible vegetation that fuel fires.

Tips For Making Your Property Fire Resistant

- Keep lawns trimmed, leaves raked, and the roof and rain-gutters free from debris such as dead limbs and leaves.
- Stack firewood at least 30 feet away from your home.
- Store flammable materials, liquids and solvents in metal containers outside the home at least 30 feet away from structures and wooden fences.
- Create defensible space by thinning trees and brush within 30 feet around your home.
- Landscape your property with fire resistant plants and vegetation to prevent fire from spreading quickly.
- Post home address signs that are clearly visible from the road.
- Provide emergency vehicle access with properly constructed driveways and roadways, at least 12 feet wide with adequate turnaround space.

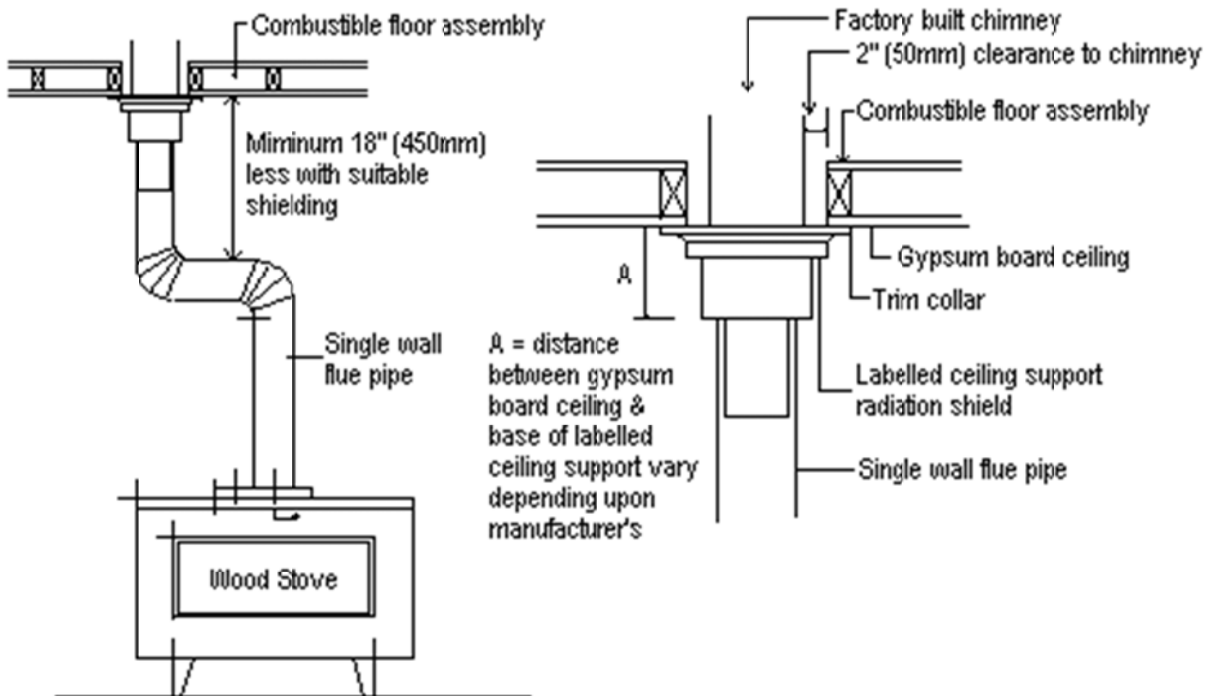

Wood Stove Installation Instructions

- Make sure water sources, such as hydrants and ponds, are accessible to the fire department.

- Burning yard waste is a fire hazard. Check with your local fire agency on a non-emergency number for fire permit requirements and restricted burning times.

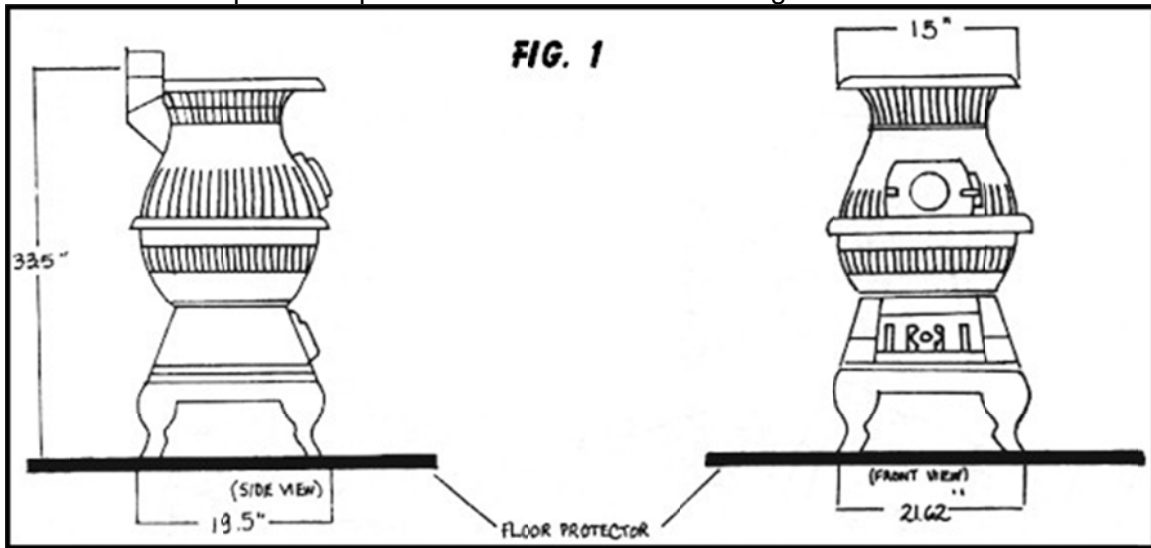

Protect Your Home

- Use fire resistant, protective roofing and materials like stone, brick and metal to protect your home. Avoid using wood materials that offer the least fire protection.
- Cover all exterior vents, attics and eaves with metal mesh screens no larger than 6 millimeters.
- Install multipane windows, tempered safety glass or fireproof shutters to protect large windows from radiant heat.
- Use fire-resistant draperies for added window protection.
- Have chimneys, wood stoves and all home heating systems inspected and cleaned annually by a certified specialist.

Prepare Your Family

- Know how to contact fire emergency services in your area.
- Plan ahead. Make sure you and your family is prepared for a fire emergency.
- Develop and practice escape and evacuation plans with your family.
- Install smoke alarms on every level of your home. Test them monthly and change the batteries at least once a year. Consider installing the new long-life smoke alarms.

Fire Definitions

Sections taken from the Fireline Handbook - January 1998

ACUTE: resulting from a single exposure to a toxic or hazardous chemical.

ADVANCED LIFE SUPPORT (ALS): Emergency medical service level provided by Paramedic certified members. It include advanced levels of care including cardiac monitoring, intravenous therapy, advanced airway management, and drug therapy.

AIR TANKER: Fixed-wing aircraft certified by FAA as being capable of transport and delivery of fire retardant solutions.

ALLERGEN: a substance capable of causing an allergic response. An allergic response is an abnormal response of a hypersensitive person to chemical and physical stimuli.

ANCHOR POINT: An advantageous location, usually a barrier to fire spread, from which to start constructing a fireline. The anchor point is used to minimize the chance of being flanked by the fire while the line is being constructed.

APPARATUS: means a motorized fire department vehicle including, but not restricted to, pumpers, elevating devices, tankers, rescue vehicles and equipment vehicles.

AREA COMMAND: An organization established to: (1) oversee the management of multiple incidents that are each being handled by an incident management team (IMT) organization; or (2) to oversee the management of a very large incident that had multiple IMT's assigned to it. Area Command has the responsibility to set overall strategy and priorities, allocate critical resources based on priorities, ensure that incidents are properly managed, and that objectives are met and strategies followed.

ASPHYXIAN: a vapor or gas that can cause unconsciousness or death due to lack of oxygen. Most simple asphyxiants are harmful to the body only when they become so concentrated that they reduce the available oxygen to 18 percent of air.

AUTOMATIC AID: response of fire companies from one or more other fire department, under written agreement authorized by law, to provide protection, incorporating an interlocking automatic response schedule between the fire departments such that responses are, in effect, those of a single department.

BACKFIRE: A fire set along the inner edge of a fireline to consume the fuel in the path of a wildfire and/or change the direction or force of the fire's convection column.

BARRIER: Any obstruction to the spread of fire. Typically an area or strip devoid of combustible fuel.

BASIC LIFE SUPPORT (BLS): Emergency medical service level provided by Emergency Medical Technician (EMT) certified members. This is the basic level of certification required of all operational members of most Fire Departments. It includes; basic splinting of sprains and broken bones, bandaging, basic airway management, cardiopulmonary resuscitation (CPR) and oxygen therapy.

BATTALION CHIEF (BC): A command officer who is in charge of one of the departments' three rotating shifts. They are available 24 hours a day and provide general day to day supervision, and support to the on duty engine and ladder companies. In addition, they are responsible for and direct all emergency activities at major incidents. Currently each BC is responsible for a variety of emergency response units and 6-7 personnel.

BIOHAZARDOUS: Describes an agent that is biological in nature and capable of self-replication and that has the capacity to produce deleterious effects on other biological organisms, particularly humans.

BLOWUP: Sudden increase in fireline intensity or rate of spread of a fire sufficient to preclude direct control or to upset existing suppression plans. Often accompanied by violent convection and may have other characteristics of a fire storm.

BOILING POINT: Temperature at which a liquid boils or changes to a vapor.

BRANCH: The organizational level having functional or geographical responsibility for major parts of incident operations. The branch level is organizationally between section and division/group in the operations section, and between section and unit in the logistics section. Branches are identified by roman numerals or by functional name (e.g., service, support).

BURN OUT: Setting fire inside a control line to consume fuel between the edge of the fire and the control line.

BURNING PERIOD: The part of each 24-hour period when fires spread most rapidly; typically from 10:00 AM to sundown.

CARCINOGENIC: describes a material capable of producing cancer in test animals and/or humans.

CHRONIC: resulting from repeated exposure to sub-lethal doses of toxic or hazardous chemicals over a period of time.

CLOSED AREA: An area in which specified activities or entry are temporarily restricted to reduce risk of human-caused fires.

CLOSURE: Legal restriction, but not necessarily elimination, of specified activities such as smoking, camping, or entry that might cause fires in a given area.

COLD TRAILING: A method of controlling a partly dead fire edge by carefully inspecting and feeling with the hand for heat to detect any fire, digging out every live spot, and trenching any live edge.

COMBUSTIBLE LIQUID: Combustible liquids have a flash point of 100°F (38°C) or higher. Non-liquid materials, such as wood or paper, are classified as ordinary combustibles.

COMMAND STAFF: The command staff consists of the information officer, safety officer and liaison officer. They report directly to the incident commander and may have an assistant or assistants, as needed.

COMPANY : means a complement of personnel operating one or more pieces of apparatus under the control of a supervisor.

COMPLEX: Two or more individual incidents located in the same general area which are assigned to a single incident commander or unified command.

CONFINE A FIRE: The least aggressive wildfire suppression strategy which can be expected to keep the fire within established boundaries of constructed firelines under prevailing conditions.

CONTAIN A FIRE: A moderately aggressive wildfire suppression strategy which can be expected to keep the fire within established boundaries of constructed firelines under prevailing conditions.

CONTROL LINE: An inclusive term for all constructed or natural barriers and treated fire edges used to control a fire.

CORROSIVE: a chemical that causes visible destruction of or irreversible alterations in living tissue by chemical action at the site of contact; a liquid that causes a severe corrosion rate in steel.

COYOTE TACTICS: A progressive line construction duty involving self-sufficient crews which build fireline until the end of the operational period, remain at or near the point while off duty, and begin building fireline again the next operational period where they left off.

CREEPING FIRE: Fire burning with a low flame and spreading slowly.

CREW: a working team assembled at the fire scene.

CROWN FIRE: A fire that advances from top to top of trees or shrubs more or less independent of a surface fire. Crown fires are sometimes classed as running or dependent to distinguish the degree of independence from the surface fire.

CROWN OUT: A fire that rises from ground into the tree crowns and advances from tree top to tree top. To intermittently ignite tree crowns as a surface fire advances.

CYTOTOXIC: describes chemicals toxic to cells because of DNA disruption.

DIRECT ATTACK: Any treatment applied directly to burning fuel such as wetting, smothering, or chemically quenching the fire or by physically separating the burning from unburned fuel.

DISPATCH TIME: The time to relay the emergency message to the first due responding company from the communications centre of first receipt.

DIVISION: Divisions are used to divide an incident into geographical areas of operation. Divisions are established when the number of resources exceeds the span-of-control of the operations chief. A division is located with the ICS organization between the branch and the task force/strike team.

DOZER LINE: Fireline constructed by the front blade of a dozer.

DOZER: Any tracked vehicle with a front mounted blade used for exposing mineral soil.

EMERGENCY MEDICAL TECHNICIAN (EMT): This is the basic level of certification required of all operational members of the most Fire Departments. It includes; basic splinting of sprains and broken bones, bandaging, basic airway management, cardiopulmonary resuscitation (CPR) and oxygen therapy.

ENGINE COMPANY: Standard fire attack unit used to deliver fire protection and emergency medical services. The average cost of a fire truck is approximately \$350,000. It is staffed by a Captain, Engineer, and two Fire Fighters. Its' main mission is to establish a water supply, perform search and rescue, and gain fire control at structural fires.

ENGINE: Any ground vehicle providing specified levels of pumping, water, and hose capacity but with less than the specified level of personnel.

ESCAPED FIRE: Fire which has exceeded or is expected to exceed initial attack capabilities or prescription.

EVOLUTION : A series of supervised activities undertaken by fire suppression staff leading to the completion of a fire or training ground function.

EXPLOSIVE: A chemical that causes sudden or instantaneous release of pressure, gas, and heat when subjected to sudden shock, pressure, or high temperature.

EXTENDED ATTACK: Situation in which a fire cannot be controlled by initial attack resources within a reasonable period of time. The fire usually can be controlled by additional resources within 24 hours after commencing suppression action.

FIRE ATTACK TEAM : One or more companies responding to a fire.

FIRE BEHAVIOR: The manner in which a fire reacts to the influences of fuel, weather, and topography.

FIRE DEMAND: A defined level of fire risk.

FIRE DEPARTMENT: A fire department organized under the Municipal Act and equipped with one or more motorized fire pumpers.

FIRE EDGE: The boundary of a fire at a given moment.

FIRE EFFECTS: The physical, biological, and ecological impacts of fire on the environment.

FIRE GROUND: The location where fire suppression and rescue are conducted.

FIRE PREVENTION: Includes inspections, investigations and public fire safety education programs.

FIRE PROTECTION SERVICES: A range of programs and services designed to protect the inhabitants of the fire department response area from the adverse effects of fire, sudden medical emergencies or exposure to dangerous conditions created by man or nature and includes prevention, rescue and suppression services.

FIRE RETARDANT: Any substance except plain water that by chemical or physical actions reduces flammability of fuels or slows their rate of combustion.

FIRE RISK: The features of a property including the occupancy which determines the potential fire severity and accompanying work load to accomplish rescue, control, extinguishment and salvage.

FIRE SHELTER: An aluminized tent offering protection by means of reflecting radiant heat and providing a volume of breathable air in a fire entrapment situation. Fire shelters should only be used in life threatening situations, as a last resort.

FIREBREAK: A natural or constructed barrier used to stop or check fires that may occur, or to provide a control line from which to work.

FIRELINE: The part of a control line that is scraped or dug to mineral soil. Also called fire trail.

FLAMMABLE LIQUID: Defined as a liquid with a flash point below 100°F (38°C), a liquid that gives off vapors readily ignitable at room temperature.

FLANKS OF A FIRE: The parts of a fire's spread perimeter that are roughly parallel to the main direction of spread.

FLARE-UP: Any sudden acceleration in rate of spread or intensification of the fire. Unlike blowup, a flare-up is of relatively short duration and does not radically change existing control plans.

FLASH FUELS: Fuels such as grass, leaves, draped pine needles, fern, tree moss and some kinds of slash, which ignite readily and are consumed rapidly when dry.

FLASH POINT: The lowest temperature at which a liquid gives off enough vapors to allow ignition

FLASHOVER: The stage of a fire at which all surfaces and objects are heated to a temperature at which flames break out almost at once over the entire surface within the space.

FOAM: The aerated solution created by forcing air into, or entraining air in water containing a foam concentrate by means of suitably designed equipment or by cascading it through the air at a high velocity. Foam reduces combustion by cooling, moistening and excluding oxygen.

FUEL TYPE: An identifiable association of fuel elements of distinctive species, form, size, arrangement, or other characteristics that will cause a predictable rate of spread or resistance to control under specified weather conditions.

FUELBREAK: A natural or manmade change in fuel characteristics which affects fire behavior so that fires burning into them can be more readily controlled.

GENERAL STAFF: The group of incident management personnel reporting to the Incident Commander. They may each have a deputy, as needed. The General Staff consists of: Operation Section Chief, Planning Section Chief, Logistics Section Chief, and a Finance/Administration Chief.

GROUND FIRE: Fire that consumes the organic material beneath the surface litter ground, such as peat fire.

HAND CREW: A number of individuals that have been organized and trained and are supervised principally for operational assignments on an incident.

HAZARDOUS CHEMICAL: Any chemical that is a physical or health hazard. The degree of hazard is generally based upon the extent of exposure or usage.

HEAD OF A FIRE: The most rapidly spreading portion of a fire's perimeter, usually to the leeward or up slope.

HEAVY FUELS: Fuels of large diameter such as snags, logs, large limb wood, which ignite and are consumed more slowly than flash fuels.

HELD LINE: All control line that still contains the fire when mop-up is completed. Excludes lost line, natural barriers not backfired, and un-used secondary lines.

HELISPOT: A natural or improved takeoff and landing area intended for temporary or occasional helicopter use.

HOLDOVER FIRE: A fire that remains dormant for a considerable time. Also called sleeper fire.

HOT SPOT: A particularly active part of a fire.

HOTSHOT CREW: Intensively trained fire crew used primarily in hand line construction.

INCIDENT COMMAND POST (ICP): Location at which primary command functions are executed. The ICP may be collocated with the incident base or other incident facilities.

INCIDENT COMMAND SYSTEM: A standardized on-scene emergency management concept specifically designed to allow its user(s) to adopt an integrated organizational structure equal to the complexity and demands of single or multiple incidents, without being hindered by jurisdictional boundaries.

INCIDENT: An occurrence, either human-caused or natural phenomena, that requires action or support by emergency service personnel to prevent or minimize loss of life or damage to property and/or natural resources.

INDIRECT ATTACK: A method of suppression in which the control line is located some considerable distance away from the fire's active edge. Generally done in the case of a fast-spreading or high-intensity fire and to utilize natural or constructed firebreaks fuelbreaks and favorable breaks in the topography. The intervening fuel is usually backfired; but occasionally the main fire is allowed to burn to the line, depending on conditions.

INFRARED (IR): A heat detection system used for fire detection, mapping, and hotspot identification.

INITIAL ATTACK: The actions taken by the first resources to arrive at a wildfire to protect lives and property, and prevent further extension of the fire.

INITIAL FIRE ATTACK TEAM: The minimum complement assembled at the fire scene capable of commencing interior rescue or fire fighting operations.

INTERVENTION TIME: The time from fire ignition to the point where the first arriving pumper, or other apparatus providing comparable functions, arrives at the fire scene and directs an extinguishing agent on the fire. For the purposes of this study intervention time is comprised of preburn time, notification time, dispatch time, travel time, setup time and first application of extinguishing agent.

IRRITANT: A non-corrosive material that causes a reversible inflammatory effect on living tissue by chemical action at the site of contact as a function of concentration or duration of exposure.

KNOCK DOWN: To reduce the flame or heat on the more vigorously burning parts of a fire edge.

LADDER COMPANY: Standard fire attack unit equipped with a hydraulic aerial ladder, an assortment of ground ladders, technical rescue equipment, forcible entry tools, and loss control equipment. The average cost of a ladder truck is approximately \$500,000. Its' main mission is to support engine companies at structural fires by shutting off gas and electric service from a structure, perform ventilation activities to remove smoke and heat form a structure on fire, and assist with search and rescue of trapped occupants. In addition, the unit provides Technical Rescue activities.

LEAD PLANE: Aircraft with pilot used to make trial runs over the target area to check wind, smoke conditions, topography and to lead air tankers to targets and supervise their drops.

LOWER EXPLOSIVE LIMIT (LEL): The lowest end of the range at which the gas or vapor level is sufficient to burn or explode if exposed to an ignition source. Below that level the mixture is too lean to burn.

MATERIAL SAFETY DATA SHEET (MSDS): Written or printed material about a hazardous chemical.

MOP-UP: Extinguishing or removing burning material near control lines, felling snags, and trenching logs to prevent rolling after an area has burned, to make a fire safe, or to reduce residual smoke.

MUTAGENIC: Capable of producing genetic changes in animals and/or humans that are passed on to future generations of offspring.

NATIONAL FIRE PROTECTION ASSOCIATION (N.F.P.A.): A U.S. based scientific and educational organization that looks at the causes, prevention and control of fire; and develops and publishes standards.

NOTIFICATION TIME: The time to register the emergency with the communications centre of first receipt from the point at which a person or device first takes steps to announce the incident.

OBSERVED VARIABLE: A variable whose value is not changed however its effects are observed.

OPTIMUM LEVEL OF PROTECTION: The combination of fire fighting staff and apparatus that delivers a suppression effort commensurate with the fire demand faced, yet representing the most efficient use of resources in a safe and effective manner.

OVERHEAD: Personnel assigned to supervisory positions, including Incident Commander, Command Staff, General Staff, Branch Directors, Supervisors, Unit Leaders, Managers, and staff.

OXIDIZER: A substance that yields oxygen readily to stimulate the combustion of other materials.

PARAMEDIC: Specially trained and capable of providing advanced life support.

PATROL: (1) To travel over a given route to prevent, detect, and suppress fires; (2) To go back and forth vigilantly over a length of control line during and/or after construction to prevent breakovers; (3) A person or group of persons who carry out patrol actions.

PERMISSIBLE EXPOSURE LIMIT (PEL): The averaged maximum concentration of a chemical in the air that a person can be exposed to repeatedly without developing health problems. Generally expressed in parts per million (ppm). Concentrations at or above the PEL make respiratory protection mandatory.

POLYMERIZATION: A condition that occurs when a substance reacts with itself and releases heat that can lead to an explosion.

PRE-BURN TIME: The time from commencement of unwanted burning to the point when notification of fire is initiated.

PREPARATION TIME: The time for a company to assemble for an emergency response after the alarm dispatch and before commencing travel time.

PYROPHORIC: Capable of spontaneous ignition when exposed to air at temperatures of 130°F or below.

RADIOACTIVE MATERIAL: Material that emits energy as alpha, beta, or gamma radiation from the nucleus of an atom. Always involves changes of one kind of atom into a different kind.

REACTIVE MATERIAL: A chemical substance or mixture that vigorously polymerizes, decomposes, condenses, or becomes self-reactive due to shock, pressure, or temperature. Includes materials or mixtures that fall within any of these categories: (1) organic peroxide, (2) pressure-generating material, and (3) water reactive material.

REBURN: (1) Repeat burning of an area over which a fire has previously passed, but left fuel that later ignites when burning conditions are more favorable; (2) An area that has reburned.

RELATIVE HUMIDITY (RH): The ratio of the amount of moisture in the air, to the maximum amount of moisture that air would contain if it were saturated. The ratio of the actual vapor pressure to the saturated vapor pressure.

REPRODUCTIVE TOXIN: Any agent that has a harmful effect on the adult male or female reproductive system or a developing fetus or child. Such hazards have a variety of effects on people, including loss of sexual drive, mental disorders, impotence, infertility, sterility, mutagenic effects on germ cells, teratogenic effects on a fetus, and transplacental carcinogenesis.

RESOURCES: (1) Personnel, equipment, services and supplies available, or potentially available, for assignment to incidents. Personnel and equipment are described by kind and type, e.g., ground, water, air, etc., and may be used in tactical, support or overhead capacities at an incident. (2) The natural resources of an area, such as timber, grass, watershed values, recreation values, and wildlife habitat.

RESPONSE TIME: The elapsed time between fire ignition and the arrival of the first unit and its crew at the occurrence location.

SAFETY ZONE: An area cleared of flammable material used for escape in the event the line is outflanked or in case a spot fire causes fuels outside the control line to render the line unsafe. In firing operations, crews progress so as to maintain a safety zone close at hand allowing the fuels inside the control line to be consumed before going ahead. Safety zones may also be constructed as integral parts of fuel breaks; they are greatly enlarged areas which can be used with relative safety by firefighters and their equipment in the event of blowup in the vicinity.

SECONDARY LINE: Any fireline constructed at a distance from the fire perimeter concurrently with or after a line already constructed on or near to the perimeter of the fire. Generally constructed as an insurance measure in case the fire escapes control by the primary line.

SENSITIZER: A material that on first exposure causes little or no reaction in humans or test animals but that after repeated exposure may cause a marked response not necessarily limited to the contact site. Skin sensitization is the most common form. Respiratory sensitization to a few chemicals is also known to occur.

SET UP TIME: The time from arrival at the fire scene until just prior to commencement of applying extinguishing agent on the fire.

SLASH: Debris resulting from such natural events as wind, fire, or snow breakage; or such human activities as road construction, logging, pruning, thinning, or brush cutting. It include logs, chunks, bark, branches, stumps, and broken understory trees or brush.

SMOKEJUMPER: A specifically trained and certified firefighter who travels to wildland fires by aircraft and parachutes to the fire.

SMOLDERING: A fire burning without flame and barely spreading.

SPECIFIC GRAVITY: A mass-to-volume comparison relative to water (1). A specific gravity below 1 will float in water, above 1 will sink.

SPOT FIRES: Fire ignited outside the perimeter of the main fire by a firebrand.

SPOTTING: Behavior of a fire producing sparks or embers that are carried by the wind and which start new fires beyond the zone of direct ignition by the main fire.

STRIKE TEAM: Specified combinations of the same kind and type of resources, with communications, and a leader.

SUPERVISOR: A person designated by department policies and guidelines to assume command of a crew or company.

SUPPRESSION CREW: Two or more firefighters stationed at a strategic location for initial action on fires. Duties are essentially the same as those of individual firefighters.

SUPPRESSION: All the work of extinguishing or confining a fire beginning with its discovery.

SURFACE FIRE: Fire that burns loose debris on the surface, which include dead branches, leaves, and low vegetation.

TACTICS: Deploying and directing resources on an incident to accomplish the objectives designated by strategy.

TARGET ORGAN EFFECT: Effects on specifically listed organs and systems, such as the liver, kidneys, nervous system, lungs, skin, and eyes, caused by exposure to a material.

TASK FORCE: Any combination or single resources assembled for a particular tactical need, with common communications and a leader. A Task Force may be pre-established and sent to an incident, or formed at an incident.

TECHNICAL RESCUE: Technical rescue is a specialized area of service provided by specially trained members of the fire department. These members are capable of providing high angle rescue, water rescue, trench and confined space rescue (cave-ins), and various other assisted rescues. This service is primarily provided by the departments' ladder company.

TERATOGENIC: Describes a material capable of producing birth defects in animals and humans.

THRESHOLD LIMIT VALUE (TLV): the quantity of chemical exposure that an individual can tolerate on a daily or routine basis during his or her working life without incurring adverse effects from the exposure.

TOTAL FIRE ATTACK TEAM: The total number of fire fighters assembled on the fire ground capable of rescue, fire containment, fire extinguishment and minimization of injury life, property and environment losses.

TOXICITY: The ability of a chemical to do harm to the human organism.

TRAVEL TIME: The time period between leaving the station and arriving at the fire scene.

TRIPLE COMBINATION PUMPER (PUMPER): A motorized vehicle designed to transport fire fighters to the scene of a fire and provide the necessary fire suppression equipment for extinguishment and equipped with a major pump, water tank, ground ladders and hose body. For the purposes of the study, a triple combination pumper equipped with elevated fire fighting capability may be substituted.

UNIFIED COMMAND: In ICS, unified command is a unified team effort which allows all agencies with jurisdictional responsibility for the incident, either geographical or functional, to manage an incident by establishing a common set of incident objectives and strategies. This is accomplished without losing or abdicating authority, responsibility, or accountability.

UNSTABLE REACTIVE: A chemical that in its pure state, or as produced or transported, will vigorously polymerize, decompose, condense, or become self-reactive under conditions of shock, pressure, or temperature.

UPPER EXPLOSIVE LIMIT (UEL): The upper end of the range at which the gas or vapor level is sufficient to burn or explode if exposed to an ignition source. Above that level the mixture is too rich to burn.

VAPOR DENSITY: Compares a chemical's vapor density to air density (1). A vapor below 1 will rise in air, above 1 will sink.

VAPOR PRESSURE: The higher the number, the faster a chemical evaporates, increasing inhalation risk.

WATER REACTIVE AGENT: A chemical that reacts with water to release a gas that is either flammable or presents a health hazard.

WATER TENDER: Any ground vehicle capable of transporting specified quantities of water.

WILDFIRE: A fire occurring on wildland that is not meeting management objectives and thus requires a suppression response.

WILDLAND: An area in which development is essentially nonexistent, except for roads, railroads, powerlines, and similar transportation facilities. Structures, if any, are widely scattered.



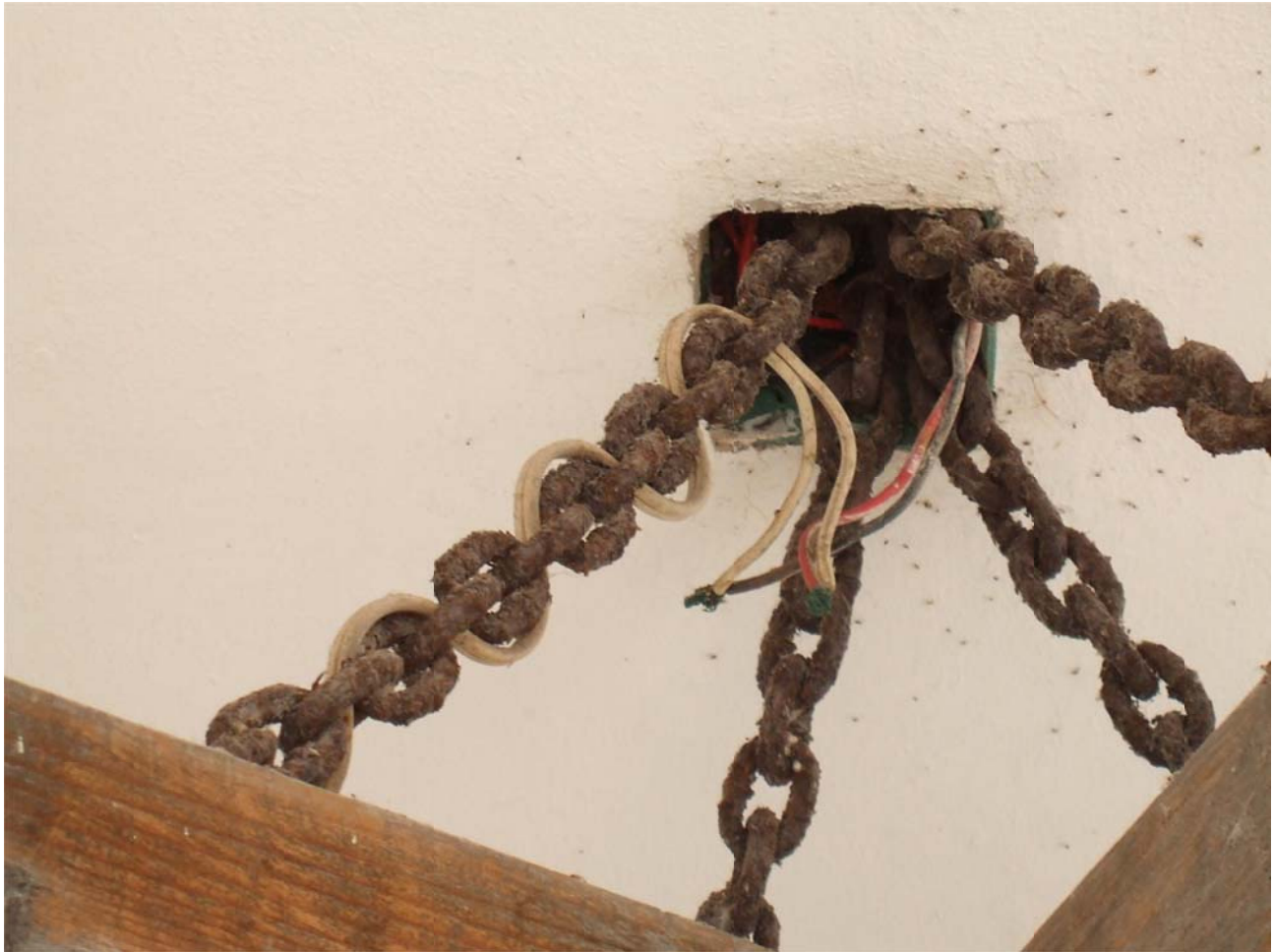

The Problem

Electrical fires in our homes claim the lives of 485 Americans each year and injure 2,305 more. Some of these fires are caused by electrical system failures and appliance defects, but many more are caused by the misuse and poor maintenance of electrical appliances, incorrectly installed wiring, and overloaded circuits and extension cords.

During a typical year, home electrical problems account for 67,800 fires, 485 deaths, and \$868 million in property losses. Home electrical wiring causes twice as many fires as electrical appliances.

Facts

December is the most dangerous month for electrical fires. Fire deaths are highest in winter months which call for more indoor activities and increase in lighting, heating, and appliance use. Most electrical wiring fires start in the bedroom.

OSHA Definitions used in the Fire Planning and Evacuation Rules

"Approved" means equipment that has been listed or approved by a nationally recognized testing laboratory such as Factory Mutual Engineering Corp., or Underwriters' Laboratories, Inc., or Federal agencies such as Bureau of Mines, or U.S. Coast Guard, which issue approvals for such equipment.

"Closed container" means a container so sealed by means of a lid or other device that neither liquid nor vapor will escape from it at ordinary temperatures.

"Combustible liquid" means any liquid having a flash point at or above 140 deg. F (60 deg. C), and below 200 deg. F (93.4 deg. C).

"Combustion" means any chemical process that involves oxidation sufficient to produce light or heat.

"Fire brigade" means an organized group of employees that are knowledgeable, trained, and skilled in the safe evacuation of employees during emergency situations and in assisting in fire fighting operations.

"Fire resistance" means so resistant to fire that, for specified time and under conditions of a standard heat intensity, it will not fail structurally and will not permit the side away from the fire to become hotter than a specified temperature. For purposes of this part, fire resistance shall be determined by the *Standard Methods of Fire Tests of Building Construction and Materials*, NFPA 251-1969.

"Flammable" means capable of being easily ignited, burning intensely, or having a rapid rate of flame spread.

"Flammable liquid" means any liquid having a flash point below 140 deg. F and having a vapor pressure not exceeding 40 pounds per square inch (absolute) at 100 deg. F.

"Flash point" of the liquid means the temperature at which it gives off vapor sufficient to form an ignitable mixture with the air near the surface of the liquid or within the vessel used as determined by appropriate test procedure and apparatus as specified below.

(1) The flash point of liquids having a viscosity less than 45 Saybolt Universal Second(s) at 100 deg. F (37.8 deg. C) and a flash point below 175 deg. F (79.4 deg. C) shall be determined in accordance with the *Standard Method of Test for Flash Point by the Tag Closed Tester*, ASTM D-56-69.

(2) The flash point of liquids having a viscosity of 45 Saybolt Universal Second(s) or more at 175 deg. F. (79.4 deg. C) or higher shall be determined in accordance with the *Standard Method of Test for Flash Point by the Pensky Martens Closed Tester*, ASTM D-93-69.

"Liquefied petroleum gases," "LPG" and "LP Gas" mean and include any material which is composed predominantly of any of the following hydrocarbons, or mixtures of them, such as propane, propylene, butane (normal butane or isobutene), and butylenes.

"Portable tank" means a closed container having a liquid capacity more than 60 U.S. gallons, and not intended for fixed installation.

"Safety can" means an approved closed container, of not more than 5 gallons capacity, having a flash-arresting screen, spring-closing lid and spout cover and so designed that it will safely relieve internal pressure when subjected to fire exposure.

"Vapor pressure" means the pressure, measured in pounds per square inch (absolute), exerted by a volatile liquid as determined by the *Standard Method of Test for Vapor Pressure of Petroleum Products (Reid Method)*, ASTM D-323-58.

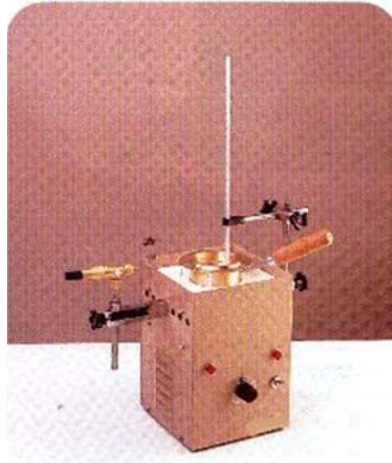

MANUAL CLEVELAND FLASH POINT TESTER

ASTM D92 - NF EN 22592 - ISO 2592 - IP 36

DEFINITION

This test method covers determination of flash and fire points of petroleum products by means of a Cleveland Open Cup tester.

CHARACTERISTICS

- Electronic regulation
- Requires external supply of butane/propane or town gas
- Needle valve for a fine adjustment of the flame
- Delivered with open cup and thermometer

SPECIFICATION

MANUAL CLEVELAND OPEN CUP TESTER in stainless steel comprising electronic regulation, pilot burner with needle valve for fine adjustment of the flame, thermometer support, Cleveland open cup and ASTM 11C thermometer.

FIRE PROTECTION - §1926.150

General Requirements

The employer shall be responsible for the development of a fire protection program to be followed throughout all phases of the construction and demolition work, and shall provide for the firefighting equipment as specified in this subpart. As fire hazards occur, there shall be no delay in providing the necessary equipment.

Access to all available firefighting equipment shall be maintained at all times. All firefighting equipment, provided by the employer, shall be conspicuously located.

All firefighting equipment shall be periodically inspected and maintained in operating condition. Defective equipment shall be immediately replaced.

As warranted by the project, the employer shall provide a trained and equipped firefighting organization (Fire Brigade) to assure adequate protection to life.

Water Supply

A temporary or permanent water supply, of sufficient volume, duration, and pressure, required to properly operate the firefighting equipment shall be made available as soon as combustible materials accumulate.

Where underground water mains are to be provided, they shall be installed, completed, and made available for use as soon as practicable.

Portable Firefighting Equipment

Fire Extinguishers and Small Hose Lines

A fire extinguisher, rated not less than 2A, shall be provided for each 3,000 square feet of the protected building area, or major fraction thereof. Travel distance from any point of the protected area to the nearest fire extinguisher shall not exceed 100 feet.

One 55-gallon open drum of water with two fire pails may be substituted for a fire extinguisher having a 2A rating.

A ½-inch diameter garden-type hose line, not to exceed 100 feet in length and equipped with a nozzle, may be substituted for a 2A-rated fire extinguisher, providing it is capable of discharging a minimum of 5 gallons per minute with a minimum hose stream range of 30 feet horizontally. The garden-type hose lines shall be mounted on conventional racks or reels. The number and location of hose racks or reels shall be such that at least one hose stream can be applied to all points in the area.

One or more fire extinguishers, rated not less than 2A, shall be provided on each floor. In multistory buildings, at least one fire extinguisher shall be located adjacent to stairway.

Extinguishers and Water Drums

Extinguishers and water drums, subject to freezing, shall be protected from freezing.

A fire extinguisher, rated not less than 10B, shall be provided within 50 feet of wherever more than 5 gallons of flammable or combustible liquids or 5 pounds of flammable gas are being used on the jobsite. This requirement does not apply to the integral fuel tanks of motor vehicles.

Carbon tetrachloride and other toxic vaporizing liquid fire extinguishers are prohibited.

Portable fire extinguishers shall be inspected periodically and maintained in accordance with *Maintenance and Use of Portable Fire Extinguishers*, NFPA No. 10A-1970. Fire extinguishers which have been listed or approved by a nationally recognized testing laboratory, shall be used to meet the requirements of this subpart.

Table F-1 in §1926.150(c)(1)(x) may be used as a guide for selecting the appropriate portable fire extinguishers.

Fire Hose and Connections

One hundred feet, or less, of 1½-inch hose, with a nozzle capable of discharging water at 25 gallons or more per minute, may be substituted for a fire extinguisher rated not more than 2A in the designated area provided that the hose line can reach all points in the area.

If fire hose connections are not compatible with local firefighting equipment, the contractor shall provide adapters, or equivalent, to permit connections.

During demolition involving combustible materials, charged hose lines, supplied by hydrants, water tank trucks with pumps, or equivalent, shall be made available.

Fixed Firefighting Equipment

Sprinkler Protection

If the facility being constructed includes the installation of automatic sprinkler protection, the installation shall closely follow the construction and be placed in service as soon as applicable laws permit following completion of each story.

During demolition or alterations, existing automatic sprinkler installations shall be retained in service as long as reasonable. The operation of sprinkler control valves shall be permitted only by properly authorized persons.

Modification of sprinkler systems to permit alterations or additional demolition should be expedited so that the automatic protection may be returned to service as quickly as possible. Sprinkler control valves shall be checked daily at close of work to ascertain that the protection is in service.



Standpipes

In all structures in which standpipes are required, or where standpipes exist in structures being altered, they shall be brought up as soon as applicable laws permit, and shall be maintained as construction progresses in such a manner that they are always ready for fire protection use.

The standpipes shall be provided with Siamese fire department connections on the outside of the structure, at the street level, which shall be conspicuously marked. There shall be at least one standard hose outlet at each floor.

Fire Alarm Devices

An alarm system, e.g., telephone system, siren, etc., shall be established by the employer whereby employees on the site and the local fire department can be alerted for an emergency. The alarm code and reporting instructions shall be conspicuously posted at phones and at employee entrances.

Fire Cutoffs

Fire walls and exit stairways, required for the completed buildings, shall be given construction priority. Fire doors, with automatic closing devices, shall be hung on openings as soon as practicable.

Fire cutoffs shall be retained in buildings undergoing alterations or demolition until operations necessitate their removal.

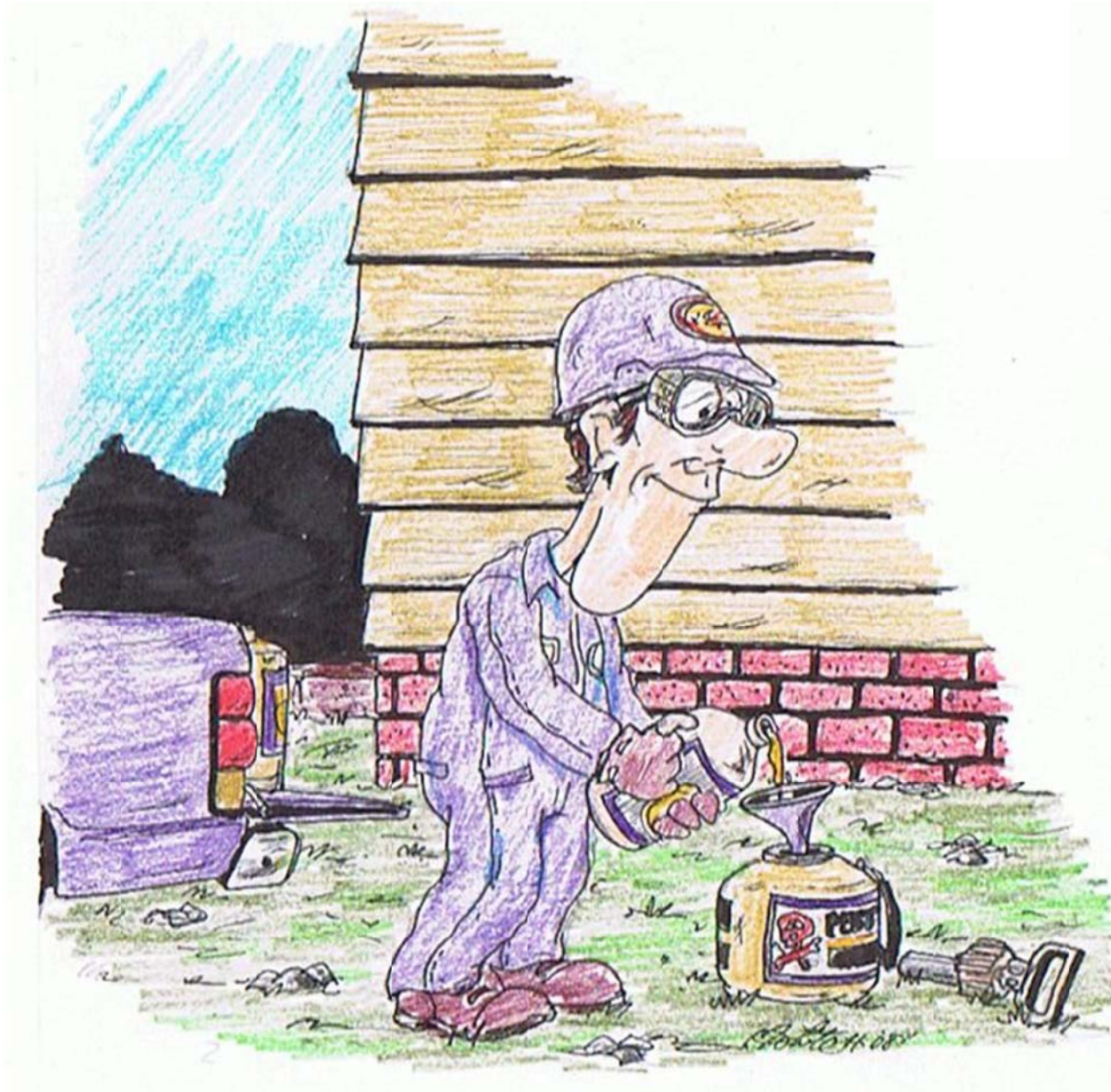

The employer shall be responsible for the development of a fire protection program to be followed throughout all phases of the construction and demolition work, and shall provide for the firefighting equipment as specified in this subpart. As fire hazards occur, there shall be no delay in providing the necessary equipment.

Access to all available firefighting equipment shall be maintained at all times. All firefighting equipment, provided by the employer, shall be conspicuously located.

All firefighting equipment shall be periodically inspected and maintained in operating condition. Defective equipment shall be immediately replaced.

As warranted by the project, the employer shall provide a trained and equipped firefighting organization (Fire Brigade) to assure adequate protection to life.

FIRE PREVENTION - §1926.151

Ignition Hazards

Electrical wiring and equipment for light, heat, or power purposes shall be installed in compliance with the requirements of Subpart K, *Electrical*.

Internal combustion engine powered equipment shall be so located that the exhausts are well away from combustible materials. When the exhausts are piped to outside the building under construction, a clearance of at least 6 inches shall be maintained between such piping and combustible material.

Smoking shall be prohibited at or in the vicinity of operations which constitute a fire hazard, and shall be conspicuously posted: "No Smoking or Open Flame."

Portable battery powered lighting equipment, used in connection with the storage, handling, or use of flammable gases or liquids, shall be of the type approved for the hazardous locations.

The nozzle of air, inert gas, and steam lines or hoses, when used in the cleaning or ventilation of tanks and vessels that contain hazardous concentrations of flammable gases or vapors, shall be bonded to the tank or vessel shell. Bonding devices shall not be attached or detached in hazardous concentrations of flammable gases or vapors.

Temporary Buildings

No temporary building shall be erected where it will adversely affect any means of exit.

Temporary buildings, when located within another building or structure, shall be of either noncombustible construction or of combustible construction having a fire resistance of not less than 1 hour.

Temporary buildings, located other than inside another building and not used for the storage, handling, or use of flammable or combustible liquids, flammable gases, explosives, or blasting agents, or similar hazardous occupancies, shall be located at a distance of not less than 10 feet from another building or structure.

Groups of temporary buildings, not exceeding 2,000 square feet in aggregate, shall, for the purposes of this part, be considered a single temporary building.

Open Yard Storage

Combustible materials shall be piled with due regard to the stability of piles and in no case higher than 20 feet.

Driveways between and around combustible storage piles shall be at least 15 feet wide and maintained free from accumulation of rubbish, equipment, or other articles or materials. Driveways shall be so spaced that a maximum grid system unit of 50 feet by 150 feet is produced.

Storage Site

The entire storage site shall be kept free from accumulation of unnecessary combustible materials. Weeds and grass shall be kept down and a regular procedure provided for the periodic cleanup of the entire area. When there is a danger of an underground fire, that land shall not be used for combustible or flammable storage.

Method of piling shall be solid wherever possible and in orderly and regular piles. No combustible material shall be stored outdoors within 10 feet of a building or structure.

Portable fire extinguishing equipment, suitable for the fire hazard involved, shall be provided at convenient, conspicuously accessible locations in the yard area. Portable fire extinguishers, rated not less than 2A, shall be placed so that maximum travel distance to the nearest unit shall not exceed 100 feet.

Indoor Storage

Storage shall not obstruct, or adversely affect, means of exit. All materials shall be stored, handled, and piled with due regard to their fire characteristics.

Noncompatible materials, which may create a fire hazard, shall be segregated by a barrier having a fire resistance of at least 1 hour.

Material shall be piled to minimize the spread of fire internally and to permit convenient access for firefighting. Stable piling shall be maintained at all times. Aisle space shall be maintained to safely accommodate the widest vehicle that may be used within the building for firefighting purposes.

Clearance of at least 36 inches shall be maintained between the top level of the stored material and the sprinkler deflectors.

Clearance shall be maintained around lights and heating units to prevent ignition of combustible materials.

A clearance of 24 inches shall be maintained around the path of travel of fire doors unless a barricade is provided, in which case no clearance is needed. Material shall not be stored within 36 inches of a fire door opening.

FLAMMABLE AND COMBUSTIBLE LIQUIDS - §1926.152

General Requirements

Only approved containers and portable tanks shall be used for storage and handling of flammable and combustible liquids. Approved metal safety cans shall be used for the handling and use of flammable liquids in quantities greater than one gallon, except that this shall not apply to those flammable liquid materials which are highly viscid (extremely hard to pour), which may be used and handled in original shipping containers. For quantities of one gallon or less, only the original container or approved metal safety cans shall be used for storage, use, and handling of flammable liquids.

Flammable or combustible liquids shall not be stored in areas used for exits, stairways, or normally used for the safe passage of people.

Indoor Storage of Flammable and Combustible Liquids

No more than 25 gallons of flammable or combustible liquids shall be stored in a room outside of an approved storage cabinet. For storage of liquefied petroleum gas, see §1926.153.

Quantities of flammable and combustible liquid in excess of 25 gallons shall be stored in an acceptable or approved cabinet meeting the following requirements:

(i) Acceptable wooden storage cabinets shall be constructed in the following manner, or equivalent: The bottom, sides, and top shall be constructed of an exterior grade of plywood at least 1 inch in thickness, which shall not break down or delaminate under standard fire test conditions. All joints shall be rabbeted and shall be fastened in two directions with flathead wood screws.

When more than one door is used, there shall be a rabbeted overlap of not less than 1 inch. Steel hinges shall be mounted in such a manner as to not lose their holding capacity due to loosening or burning out of the screws when subjected to fire. Such cabinets shall be painted inside and out with fire retardant paint.

(ii) Approved metal storage cabinets will be acceptable.

(iii) Cabinets shall be labeled in conspicuous lettering, "Flammable-Keep Fire Away."

Not more than 60 gallons of flammable or 120 gallons of combustible liquids shall be stored in any one storage cabinet. Not more than three such cabinets may be located in a single storage area. Quantities in excess of this shall be stored in an inside storage room.

Inside storage rooms shall be constructed to meet the required fire-resistive rating for their use.

Such construction shall comply with the test specifications set forth in *Standard Methods of Fire Test of Building Construction and Material*, NFPA 251-1969.

Where an automatic extinguishing system is provided, the system shall be designed and installed in an approved manner. Openings to other rooms or buildings shall be provided with noncombustible liquid-tight raised sills or ramps at least 4 inches in height, or the floor in the storage area shall be at least 4 inches below the surrounding floor. Openings shall be provided with approved self-closing fire doors. The room shall be liquid-tight where the walls join the floor. A permissible alternate to the sill or ramp is an open-grated trench, inside of the room, which drains to a safe location.

Where other portions of the building or other buildings are exposed, windows shall be protected as set forth in the *Standard for Fire Doors and Windows*, NFPA No. 80-1970, for Class E or F openings. Wood of at least 1-inch nominal thickness may be used for shelving, racks, dunnage, scuffboards, floor overlay, and similar installations.

Materials which will react with water and create a fire hazard shall not be stored in the same room with flammable or combustible liquids.

Storage in inside storage rooms shall comply with Table F-2:

TABLE F-2			
Fire Protection Provided	Fire Resistance	Maximum Size	Total Allowable Quantities (gal./sq. ft. floor area)
Yes	2 hrs.	500 sq. ft.	10
No	2 hrs.	500 sq. ft.	4
Yes	1 hr.	150 sq. ft.	5
No	1 hr.	150 sq. ft.	2

NOTE: Fire protection system shall be sprinkler, water spray, carbon dioxide or other system approved by a nationally recognized testing laboratory for this purpose.

Electrical wiring and equipment located in inside storage rooms shall be approved for Class I, Division 1, Hazardous Locations. For definition of Class I, Division 1, Hazardous Locations, see §1926.449.

Every inside storage room shall be provided with either a gravity or a mechanical exhausting system. Such system shall commence not more than 12 inches above the floor and be designed to provide for a complete change of air within the room at least 6 times per hour. If a mechanical exhausting system is used, it shall be controlled by a switch located outside of the door. The ventilating equipment and any lighting fixtures shall be operated by the same switch. An electric pilot light shall be installed adjacent to the switch if flammable liquids are dispensed within the room. Where gravity ventilation is provided, the fresh air intake, as well as the exhausting outlet from the room, shall be on the exterior of the building in which the room is located.

In every inside storage room there shall be maintained one clear aisle at least 3 feet wide. Containers over 30 gallons capacity shall not be stacked one upon the other.

Storage Outside Buildings

Flammable and combustible liquids in excess of that permitted in inside storage rooms shall be stored outside of buildings in accordance with paragraph "Storage Outside Buildings" of this section.

The quantity of flammable or combustible liquids kept in the vicinity of spraying operations shall be the minimum required for operations and should ordinarily not exceed a supply for 1 day or one shift. Bulk storage of portable containers of flammable or combustible liquids shall be in a separate, constructed building detached from other important buildings or cut off in a standard manner.

Storage Outside Buildings

Storage of containers (not more than 60 gallons each) shall not exceed 1,100 gallons in any one pile or area. Piles or groups of containers shall be separated by a 5-foot clearance. Piles or groups of containers shall not be nearer than 20 feet to a building.

Within 200 feet of each pile of containers, there shall be a 12-foot-wide access way to permit approach of fire control apparatus.

The storage area shall be graded in a manner to divert possible spills away from buildings or other exposures, or shall be surrounded by a curb or earth dike at least 12 inches high. When curbs or dikes are used, provisions shall be made for draining off accumulations of ground or rain water, or spills of flammable or combustible liquids. Drains shall terminate at a safe location and shall be accessible to operation under fire conditions.

Outdoor portable tank storage:

(i) Portable tanks shall not be nearer than 20 feet from any building. Two or more portable tanks, grouped together, having a combined capacity in excess of 2,200 gallons, shall be separated by a 5-foot-clear area. Individual portable tanks exceeding 1,100 gallons shall be separated by a 5-foot-clear area.

(ii) Within 200 feet of each portable tank, there shall be a 12-foot-wide access way to permit approach of fire control apparatus.

Storage areas shall be kept free of weeds, debris, and other combustible material not necessary to the storage.

Portable tanks, not exceeding 660 gallons, shall be provided with emergency venting and other devices, as required by chapters III and IV of NFPA 30-1969, *The Flammable and Combustible Liquids Code*.

Portable tanks, in excess of 660 gallons, shall have emergency venting and other devices, as required by chapters II and III of *The Flammable and Combustible Liquids Code*, NFPA 30-1969.

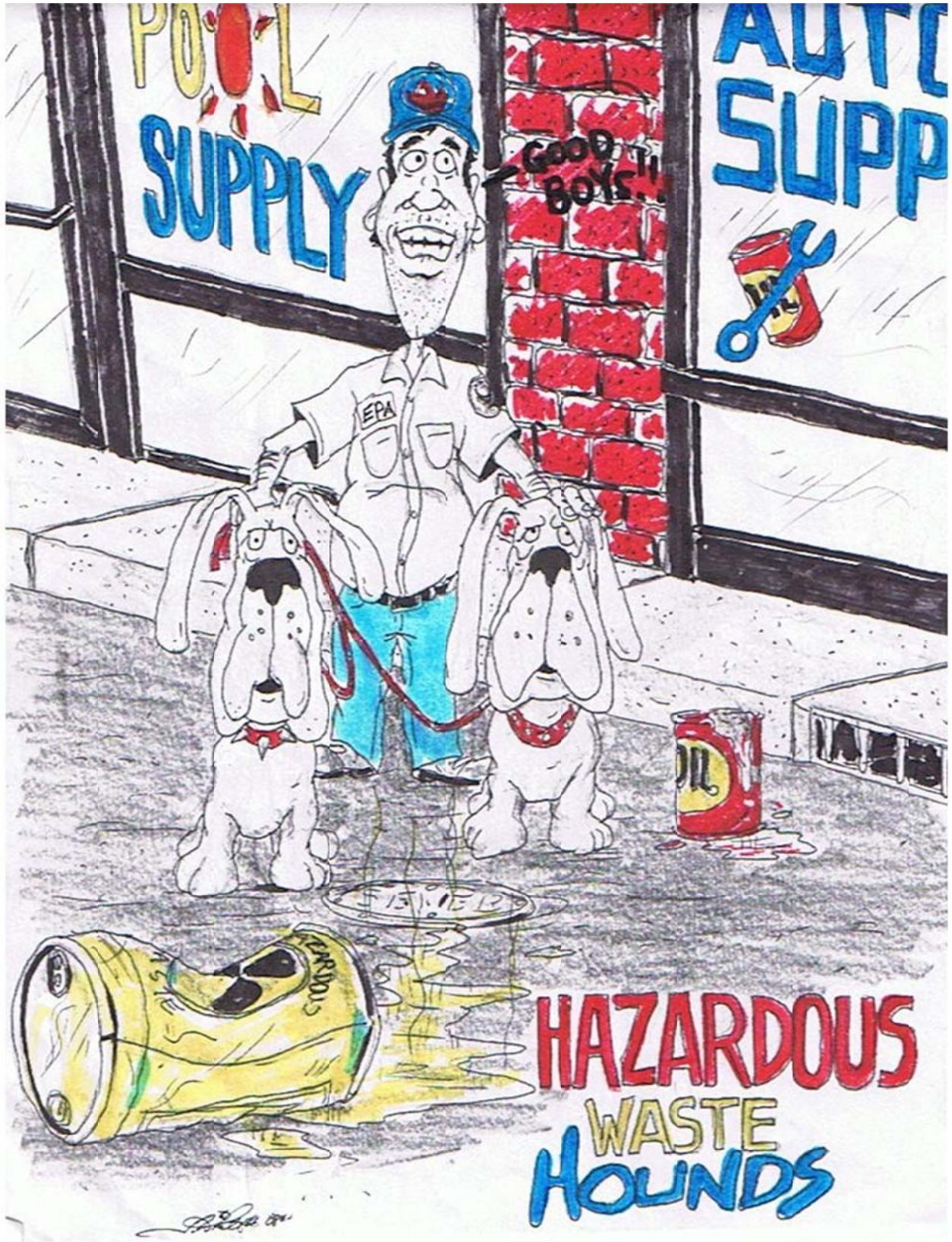

Fire Control for Flammable or Combustible Liquid Storage

At least one portable fire extinguisher, having a rating of not less than 20-B units, shall be located outside of, but not more than 10 feet from, the door opening into any room used for storage of more than 60 gallons of flammable or combustible liquids.

At least one portable fire extinguisher having a rating of not less than 20-B units shall be located not less than 25 feet, nor more than 75 feet, from any flammable liquid storage area located outside.

When sprinklers are provided, they shall be installed in accordance with the *Standard for the Installation of Sprinkler Systems*, NFPA 13-1969.

At least one portable fire extinguisher having a rating of not less than 20-B:C units shall be provided on all tank trucks or other vehicles used for transporting and/or dispensing flammable or combustible liquids.

Dispensing Liquids

Areas in which flammable or combustible liquids are transferred at one time, in quantities greater than 5 gallons from one tank or container to another tank or container, shall be separated from other operations by 25-foot distance or by construction having a fire resistance of at least 1 hour. Drainage or other means shall be provided to control spills. Adequate natural or mechanical ventilation shall be provided to maintain the concentration of flammable vapor at or below 10 percent of the lower flammable limit.

Transfer of flammable liquids from one container to another shall be done only when containers are electrically interconnected (bonded).

Flammable or combustible liquids shall be drawn from or transferred into vessels, containers, or tanks within a building or outside only through a closed piping system, from safety cans, by means of a device drawing through the top, or from a container, or portable tanks, by gravity or pump, through an approved self-closing valve.

Transferring by means of air pressure on the container or portable tanks is prohibited.

The dispensing units shall be protected against collision damage. Dispensing devices and nozzles for flammable liquids shall be of an approved type.

Handling Liquids at Point of Final Use

Flammable liquids shall be kept in closed containers when not actually in use.

Leakage or spillage of flammable or combustible liquids shall be disposed of promptly and safely.

Flammable liquids may be used only where there are no open flames or other sources of ignition within 50 feet of the operation, unless conditions warrant greater clearance.

Service and Refueling Areas

Flammable or combustible liquids shall be stored in approved closed containers, in tanks located underground, or in aboveground portable tanks.

The tank trucks shall comply with the requirements covered in the *Standard for Tank Vehicles for Flammable and Combustible Liquids*, NFPA No. 385-1966.

The dispensing hose shall be an approved type, and the dispensing nozzle shall be an approved automatic-closing type without a latch-open device.

Underground tanks shall not be abandoned.

Clearly identified and easily accessible switch(es) shall be provided at a location remote from dispensing devices to shut off the power to all dispensing devices in the event of an emergency.

Heating equipment of an approved type may be installed in the lubrication or service area where there is no dispensing or transferring of flammable liquids, provided the bottom of the heating unit is at least 18 inches above the floor and is protected from physical damage.

Heating equipment installed in lubrication or service areas, where flammable liquids are dispensed, shall be of an approved type for garages, and shall be installed at least 8 feet above the floor.

There shall be no smoking or open flames in the areas used for fueling, servicing fuel systems for internal combustion engines, receiving or dispensing of flammable or combustible liquids. Conspicuous and legible signs prohibiting smoking shall be posted.

The motors of all equipment being fueled shall be shut off during the fueling operation.

Each service or fueling area shall be provided with at least one fire extinguisher having a rating of not less than 20-B:C located so that an extinguisher will be within 75 feet of each pump, dispenser, underground fill pipe opening, and lubrication or service area.

Scope

This section applies to the handling, storage, and use of flammable and combustible liquids with a flashpoint below 200 deg. F (93.33 deg. C). This section does not apply to: (1) Bulk transportation of flammable and combustible liquids; and (2) Storage, handling, and use of fuel oil tanks and containers connected with oil burning equipment.

Tank Storage

Refer to §1926.152(i) for design, construction, and installation requirements for flammable or combustible liquid storage tanks.

Piping, Valves, and Fittings

Refer to §1926.152(j) for design, fabrication, assembly, test, and inspection requirements for piping systems containing flammable or combustible liquids.

Marine Service Stations

Refer to §1926.152(k) for dispensing, tanks and pumps, and piping service stations where flammable or combustible liquids used as fuels are stored and dispensed.



2 x ¾ inch mechanical service tap.



Electrical Wiring

- Most electrical fires result from problems with "fixed wiring" such as faulty electrical outlets and old wiring. Problems with cords and plugs, such as extension and appliance cords, also cause many home electrical fires.
- In urban areas, faulty wiring accounts for 33% of residential electrical fires.
- Many avoidable electrical fires can be traced to misuse of electric cords, such as overloading circuits, poor maintenance and running the cords under rugs or in high traffic areas.

Home Appliances

- The home appliances most often involved in electrical fires are electric stoves and ovens, dryers, central heating units, televisions, radios and record players.

Liquefied Petroleum Gas (LP-GAS) - §1926.153

Approval of Equipment and Systems

Each system shall have containers, valves, connectors, manifold valve assemblies, and regulators of an approved type.

All cylinders shall meet the Department of Transportation specification identification requirements published in 49 CFR Part 178, ***Shipping Container Specifications***.

As used in this section, "***Containers***" are defined as all vessels, such as tanks, cylinders, or drums, used for transportation or storing liquefied petroleum gases.

Welding on LP-Gas Containers

Welding is prohibited on containers.

Container Valves and Container Accessories

Valves, fittings, and accessories connected directly to the container, including primary shut off valves, shall have a rated working pressure of at least 250 p.s.i.g. and shall be of material and design suitable for LP-Gas service.

Connections to containers, except safety relief connections, liquid level gauging devices, and plugged openings, shall have shutoff valves located as close to the container as practicable.

Safety Devices

Every container and every vaporizer shall be provided with one or more approved safety relief valves or devices.

These valves shall be arranged to afford free vent to the outer air with discharge not less than 5 feet horizontally away from any opening into a building which is below such discharge.

Shutoff valves shall not be installed between the safety relief device and the container, or the equipment or piping to which the safety relief device is connected, except that a shutoff valve may be used where the arrangement of this valve is such that full required capacity flow through the safety relief device is always afforded.

Container safety relief devices and regulator relief vents shall be located not less than 5 feet in any direction from air openings into sealed combustion system appliances or mechanical ventilation air intakes.

Dispensing

Filling of fuel containers for trucks or motor vehicles from bulk storage containers shall be performed not less than 10 feet from the nearest masonry-walled building, or not less than 25 feet from the nearest building or other construction and, in any event, not less than 25 feet from any building opening.

Filling of portable containers or containers mounted on skids from storage containers shall be performed not less than 50 feet from the nearest building.

Requirements for Appliances

Any appliance that was originally manufactured for operation with a gaseous fuel other than LP-Gas, and is in good condition, may be used with LP-Gas only after it is properly converted, adapted, and tested for performance with LP-Gas before the appliance is placed in use.

Containers shall be upright upon firm foundations or otherwise firmly secured. The possible effect on the outlet piping of settling shall be guarded against by a flexible connection or special fitting.

Containers and Equipment Used Inside of Buildings or Structures

When operational requirements make portable use of containers necessary, and their location outside of buildings or structures is impracticable, containers and equipment shall be permitted to be used inside of buildings or structures in accordance with paragraphs (h)(2) through (11) of this section.

"**Containers in use**" means connected for use.

Systems utilizing containers having a water capacity greater than 2½ pounds (nominal 1 pound LP-Gas capacity) shall be equipped with excess flow valves. Such excess flow valves shall be either integral with the container valves or in the connections to the container valve outlets.

Regulators shall be either directly connected to the container valves or to manifolds connected to the container valves. The regulator shall be suitable for use with LP-Gas. Manifolds and fittings connecting containers to pressure regulator inlets shall be designed for at least 250 p.s.i.g. service pressure.

Valves on containers having water capacity greater than 50 pounds (nominal 20 pounds LP-Gas capacity) shall be protected from damage while in use or storage.

Aluminum piping or tubing shall not be used.

Hose shall be designed for a working pressure of at least 250 p.s.i.g. Design, construction, and performance of hose, and hose connections shall have their suitability determined by listing by a nationally recognized testing agency.

The hose length shall be as short as practicable. Hoses shall be long enough to permit compliance with spacing provisions of paragraphs (h)(1) through (13) of this section, without kinking or straining, or causing hose to be so close to a burner as to be damaged by heat.

Portable heaters, including salamanders, shall be equipped with an approved automatic device to shut off the flow of gas to the main burner, and pilot if used, in the event of flame failure.

Such heaters, having inputs above 50,000 B.T.U.s per hour, shall be equipped with either a pilot, which must be lighted and proved before the main burner can be turned on, or an electrical ignition system.

NOTE: The provisions of this subparagraph do not apply to portable heaters under 7,500 B.T.U.s per hour input when used with containers having a maximum water capacity of 2½ pounds.

Container valves, connectors, regulators, manifolds, piping, and tubing shall not be used as structural supports for heaters.

Containers, regulating equipment, manifolds, pipe, tubing, and hose shall be located to minimize exposure to high temperatures or physical damage.

Containers having a water capacity greater than 2½ pounds (nominal 1 pound LP-Gas capacity) connected for use shall stand on a firm and substantially level surface and, when necessary, shall be secured in an upright position.

The maximum water capacity of individual containers shall be 245 pounds (nominal 100 pounds LP-Gas capacity).

For temporary heating, heaters (other than integral heater-container units) shall be located at least 6 feet from any LP-Gas container.

This shall not prohibit the use of heaters specifically designed for attachment to the container or to a supporting standard, provided they are designed and installed so as to prevent direct or radiant heat application from the heater onto the containers. Blower and radiant type heaters shall not be directed toward any LP-Gas container within 20 feet.

If two or more heater-container units, of either the integral or nonintegral type, are located in an unpartitioned area on the same floor, the container or containers of each unit shall be separated from the container or containers of any other unit by at least 20 feet.

When heaters are connected to containers for use in an unpartitioned area on the same floor, the total water capacity of containers, manifolded together for connection to a heater or heaters, shall not be greater than 735 pounds (nominal 300 pounds LP-Gas capacity).

Such manifolds shall be separated by at least 20 feet.

Storage of containers awaiting use shall be in accordance with paragraphs (j) and (k) of this section.

Multiple Container Systems

Valves in the assembly of multiple container systems shall be arranged so that replacement of containers can be made without shutting off the flow of gas in the system. This provision is not to be construed as requiring an automatic changeover device.

Heaters shall be equipped with an approved regulator in the supply line between the fuel cylinder and the heater unit. Cylinder connectors shall be provided with an excess flow valve to minimize the flow of gas in the event the fuel line becomes ruptured.

Regulators and low-pressure relief devices shall be rigidly attached to the cylinder valves, cylinders, supporting standards, the building walls, or otherwise rigidly secured, and shall be so installed or protected from the elements.

Storage of LPG Containers

Storage of LPG within buildings is prohibited.

Storage Outside of Buildings

Storage outside of buildings, for containers awaiting use, shall be located from the nearest building or group of buildings, in accordance with the following:

TABLE F-3	
Quantity of LP-Gas Stored	Distance (feet)
500 lbs. or less	0
501 to 6,000 lbs.	10
6,001 to 10,000 lbs.	20
Over 10,000 lbs	25

Containers shall be in a suitable ventilated enclosure or otherwise protected against tampering.

Fire Protection

Storage locations shall be provided with at least one approved portable fire extinguisher having a rating of not less than 20-B:C.



Systems Utilizing Containers Other Than DOT Containers

This paragraph applies specifically to systems utilizing storage containers other than those constructed in accordance with DOT specifications. Paragraph (b) of this section applies to this paragraph unless otherwise noted in paragraph (b) of this section.

Storage containers shall be designed and classified in accordance with Table F-31 of §1926.153(m)(2).

Containers with foundations attached (portable or semiportable containers with suitable steel "runners" or "skids" and popularly known in the industry as "skid tanks") shall be designed, installed, and used in accordance with these rules subject to the following provisions:

(i) If they are to be used at a given general location for a temporary period not to exceed 6 months they need not have fire-resisting foundations or saddles but shall have adequate ferrous metal supports.

(ii) They shall not be located with the outside bottom of the container shell more than 5 feet (1.52 m) above the surface of the ground unless fire-resisting supports are provided.

(iii) The bottom of the skids shall not be less than 2 inches (5.08 cm) or more than 12 inches (30.48 cm) below the outside bottom of the container shell.

(iv) Flanges, nozzles, valves, fittings, and the like, having communication with the interior of the container, shall be protected against physical damage.

(v) When not permanently located on fire-resisting foundations, piping connections shall be sufficiently flexible to minimize the possibility of breakage or leakage of connections if the container settles, moves, or is otherwise displaced.

(vi) Skids, or lugs for attachment of skids, shall be secured to the container in accordance with the code or rules under which the container is designed and built (with a minimum factor of safety of four) to withstand loading in any direction equal to four times the weight of the container and attachments when filled to the maximum permissible loaded weight.

Field welding where necessary shall be made only on saddle plates or brackets which were applied by the manufacturer of the tank.

Marking of Gas Cylinders

When LP-Gas and one or more other gases are stored or used in the same area, the containers shall be marked to identify their content. Marking shall be in compliance with American National Standard Z48.1-1954, *Method of Marking Portable Compressed Gas Containers To Identify the Material Contained*.

Damage From Vehicles

When damage to LP-Gas systems from vehicular traffic is a possibility, precautions against such damage shall be taken.



The following agencies can provide more information on Propane:

CHEMTREC
(800) 262-8200
www.chemtrec.org

PERS - Professional Emergency Resource Services
(800) 728-2482
www.pers-er.com

Infotrac
(800) 535-5053
www.infotrac.net

Chem-tel Inc.
(813) 248-0573
www.chemtelinc.com



Propane Storage

Retail propane storage facilities are known in the propane industry as "bulk plants." In the United States, there are 13,500 bulk plants that contain one or more propane tanks, with typically 18,000 to 30,000 gallons storage capacity each.

Bulk propane storage tanks are constructed of steel in accordance with the Boiler and Pressure Vessel Code, Section VIII of the American Society of Mechanical Engineers (ASME) and the requirements of state and municipal authorities. The tanks are equipped and located as set forth in NFPA 58, "Liquefied Petroleum Gas Code." Each storage tank, depending on size, is set a specific distance away from other tanks, buildings, and property lines.

- Bulk storage tanks are always installed on a firm foundation and are protected by an enclosure to prevent trespassing and tampering.
- Tanks are painted light, reflective colors for both safety and appearance.

Safety Record

The U.S. propane industry has a proud safety record, with equal emphasis on the adoption of sound engineering principles, up-to-date employee training, and educating consumers on the safe use of propane.

The industry's safety record has been praised in the *Congressional Record*, and such organizations as the National Fire Protection Association, the U.S. Chemical Safety Board, and the International Association of Fire Chiefs have public acknowledged the propane industry's commitment to safety.

Storage and Distribution Safety

Transferring Propane Safely from Truck to Tank

Pumps are used to transfer propane from the tank truck to the consumer storage tank. Various valves and accessories are required by NFPA 58 and the U.S. Department of Transportation to enhance the safety of the transfer operation.

The following safety valves are typically found on containers or used during the transfer of liquid propane to residential storage systems:

- **Pressure Relief Valves**—Propane tanks are protected by pressure relief valves that open and close to prevent excessive internal pressure due to abnormal conditions.
- **Excess Flow Valves**—These valves can be found on the storage tank, the loading facility known as the “*bulk head*” and on the delivery vehicle. They provide protection during product transfer or anytime that propane flows through them, including during normal operating periods. Should the flow of propane exceed the valve's setting, which might occur if the piping downstream of the valve is broken, the valve will automatically close and shut off the flow of propane.
- **Line Valves**—These manually operated valves are used to control flow into or out of the system or to isolate piping for maintenance purposes. Other valves are used with bulk storage tanks and tank trucks where special attention and protective measures are needed.
- **Remote Shutoff Systems**—New bobtail delivery trucks, and by 2006 all existing bobtail trucks, will be equipped with radio-controlled systems or other DOT-approved systems that can shut off the main truck valve and the truck's engine if the operator detects a leak in the system.
- **Passive Shutoff Systems**—New propane transports and as of July 1, 2001, re-qualified existing transports, will be protected with a “*passive*” product control system that will automatically stop the flow of propane if a line separation occurs.

CHEMTREC

The Chemical Transportation Emergency Center (**CHEMTREC**) is operated by the Chemical Manufacturers Association in Arlington, Virginia.

CHEMTREC is a public service that provides 24-hour telephone service, seven days a week, to supply emergency response information and coordinate shipper and carrier efforts in coping with transportation accidents involving hazardous materials.

In 1981, the Department of Energy released a report containing an analytical examination of fatal accidents involving propane gas transportation and storage between 1971 and 1979. The purpose of the investigation was to assess the risks associated with propane storage and transportation.

According to this report, the individual risk is about one death per 37 million persons; about the same as the risk of a person on the ground being killed by an airplane crash, and much less than the risk of death by lightning, tornadoes, or dam failures.

See the following table for a summary of average annual fatalities and individual risk comparisons contained in the report titled, “**LPG Land Transportation and Storage Safety.**”

Safety Training and Education

To further enhance the industry's safety and service, a number of training programs and efforts have been implemented throughout the country.

AVERAGE ANNUAL FATALITIES AND INDIVIDUAL RISK COMPARISONS

EVENT AVERAGE FATALITIES INDIVIDUAL RISK*

Voluntary Risk

Motor Vehicle Accident 46,700 1 in 4,700

Air Crashes (persons in plane) 1,552 1 in 140,000

Involuntary Risk

Lightning 160 1 in 1,375,000

Tornadoes 90 1 in 2,450,000

Dam Failures 35 1 in 6,300,000

Air Crashes (persons on ground) 6** 1 in 37,000,000

LPG Transportation/Storage Accidents

6** 1 in 37,000,000

* Based on U.S. population of 222,000,000.

** Applies only to members of the general public, i.e., persons at the scene of the accident through coincidence or curiosity.

(Table S-2: Department of Energy "LPG Land Transportation and Storage Safety," December 1981)

For Propane Industry Personnel

In keeping with the industry's high safety standards, NPGA has developed the Certified Employee Training Program (**CETP**), which provides service personnel with a complete technical training curriculum. The areas covered include:

- Basic Principles & Practices
- Propane Delivery
- Plant Operations
- Distribution System Operations
- Transfer System Operations
- Appliance Installation
- Appliance Service
- Large Equipment Connection & Service



Important industry references such as ANSI Z223.1/NFPA 54, "**The National Fuel Gas Code**," and NFPA 58, "**Liquefied Petroleum Gas Code**" are utilized in the development of this material.

Each year, thousands of industry employees and firefighters attend service and safety schools sponsored by the industry. The sessions provide important training in the methods of quickly controlling and safely handling a propane emergency.

The award-winning **Propane Emergencies** program was created to provide a uniform curriculum to help America's emergency responders and firefighters develop the knowledge and skills necessary to safely and effectively manage a propane emergency in transportation or at fixed facilities. Visit www.propanesafety.com for more information.

For Homeowners

Home appliances and fuel systems need regular check-ups to keep them running properly, just as automobiles do. That is why the National Propane Gas Association (**NPGA**) developed the Gas Appliance System Check (**GAS Check®**) program.

This national safety program was designed to reduce the chances of residential accidents involving propane gas. A GAS Check® inspection allows service personnel to explain in everyday terms the safety features of gas appliances. The service technician checks the entire propane system for leaks and makes sure that every element satisfies local regulations and industry standards.

The technician also familiarizes homeowners with the distinctive smell of propane and provides other important safety information. If there is any worn or damaged equipment that should be replaced, the consumer is informed and advised of the options for correcting the problem or improving the system.

The GAS Check® technician also provides instructional materials and advises the consumer about the most efficient and safest way to operate the propane system. The GAS Check® program has been so successful that it is nationally recognized as an important home safety program.

The National Fire Protection Association awarded GAS Check® its Organization Member Award in 1985 for the best example of a public fire safety program.

National Propane Gas Association (NPGA)

Founded in 1931, the National Propane Gas Association (**NPGA**) is the only national trade association for the U.S. propane gas industry. With a membership including both small, family-owned businesses and large, multi-state corporations, NPGA represents every segment of the industry—retail marketers of propane gas and appliances; producers and wholesalers of LP-gas; appliance and equipment manufacturers and distributors; tank and cylinder fabricators; transporters; and consultants.

In addition to 3,700 U.S. member companies, NPGA membership includes international members from 28 countries. Governed by an elected Board of Directors, NPGA develops programs and activities through its Executive Committee and seven standing committees.

NPGA's Mission

NPGA's mission is to promote the safe and increased use of propane, to work for a favorable environment for production, distribution and marketing, and to serve as the principal voice of the propane industry.

Strategic Initiatives

- To promote safety in the propane industry.
- To achieve favorable governmental actions on propane issues.
- To provide forums for communication within the industry.
- To anticipate and respond to challenges and opportunities that face our industry and members.

Approximate Properties Of LP-Gases (Commercial Propane)

Specific gravity of liquid at 60 degrees F 0.504 Latent heat of vaporization at boiling point:

Initial boiling point at 14.7 psia, degrees F -44.0 (a) Btu per pound 184

Weight per gallon of liquid at 60 degrees F, lb 4.20 (b) Btu per gallon 773

Specific heat of liquid, Btu/lb. At 60 degrees F 0.630

Total heating values after vaporization:

Cubic ft. of vapor per gallon at 60 degrees F 36.38 (a) Btu per cubic foot 2,488

Cubic ft. of vapor per pound at 60 degrees F 8.66 (b) Btu per pound 21,548

Specific gravity of vapor (air=1) at 60 degrees F 1.50 (c) Btu per gallon 91,502

Ignition temperature in air, degrees F 920-1120 Molecular weight 44.094

Maximum flame temperature in air, degrees F 3,595 Chemical formula C₃H₈

Limits of flammability in air, Percent of vapor in air-gas mixture:

Vapor pressure in psig

70 degrees F 127

(a) Lower 2.15 100 degrees F 196

(b) Upper 9.60 105 degrees F 210

130 degrees F 287

NFPA 58, Liquefied Petroleum Gas Code, 1998 Edition, Table B-1.2

NPGA #3026 Rev. 4/10/01



Propane Tanker truck hookup for mass storage facilities.



Fusion Butt Joint on plastic pipe.

Mechanical (compression) joint on plastic.

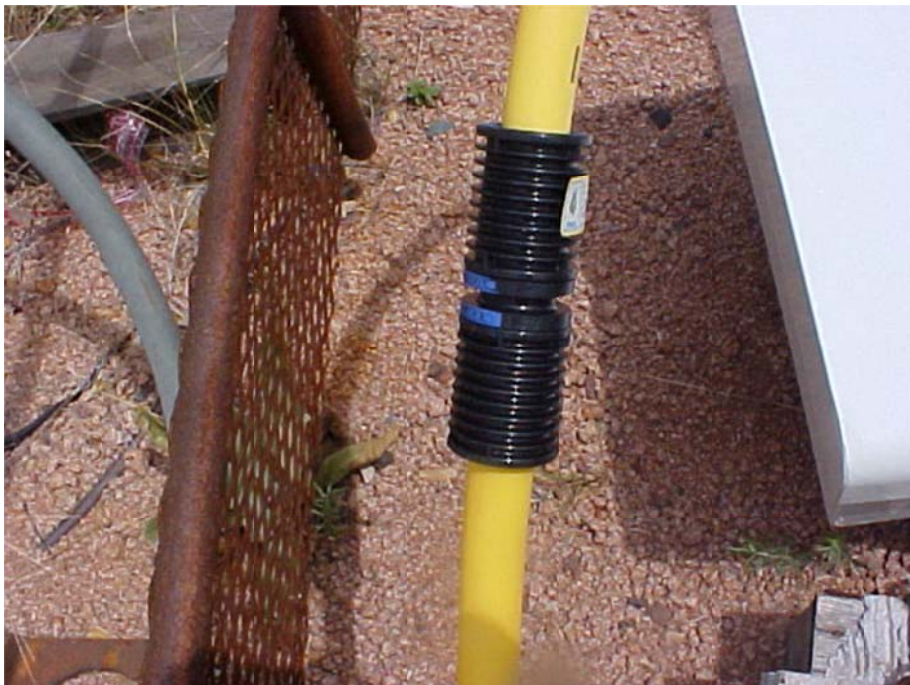

Temporary Heating Devices - §1926.154

Ventilation

Fresh air shall be supplied in sufficient quantities to maintain the health and safety of workers. Where natural means of fresh air supply is inadequate, mechanical ventilation shall be provided.

When heaters are used in confined spaces, special care shall be taken to provide sufficient ventilation in order to ensure proper combustion, maintain the health and safety of workers, and limit temperature rise in the area.

Clearance and Mounting

Temporary heating devices shall be installed to provide clearance to combustible material not less than the amount shown in Table F-4 in §1926.154(b)(1).

Temporary heating devices, which are listed for installation with lesser clearances than specified in Table F-4, may be installed in accordance with their approval.

Heaters not suitable for use on wood floors shall not be set directly upon them or other combustible materials. When such heaters are used, they shall rest on suitable heat insulating material or at least 1-inch concrete, or equivalent. The insulating material shall extend beyond the heater 2 feet or more in all directions.

Heaters used in the vicinity of combustible tarpaulins, canvas, or similar coverings shall be located at least 10 feet from the coverings. The coverings shall be securely fastened to prevent ignition or upsetting of the heater due to wind action on the covering or other material.

Stability

Heaters, when in use, shall be set horizontally level, unless otherwise permitted by the manufacturer's markings.

Solid Fuel Salamanders

Solid fuel salamanders are prohibited in buildings and on scaffolds.

Oil-Fired Heaters

Flammable liquid-fired heaters shall be equipped with a primary safety control to stop the flow of fuel in the event of flame failure. Barometric or gravity oil feed shall not be considered a primary safety control.

Heaters designed for barometric or gravity oil feed shall be used only with the integral tanks.

Heaters specifically designed and approved for use with separate supply tanks may be directly connected for gravity feed, or an automatic pump, from a supply tank.

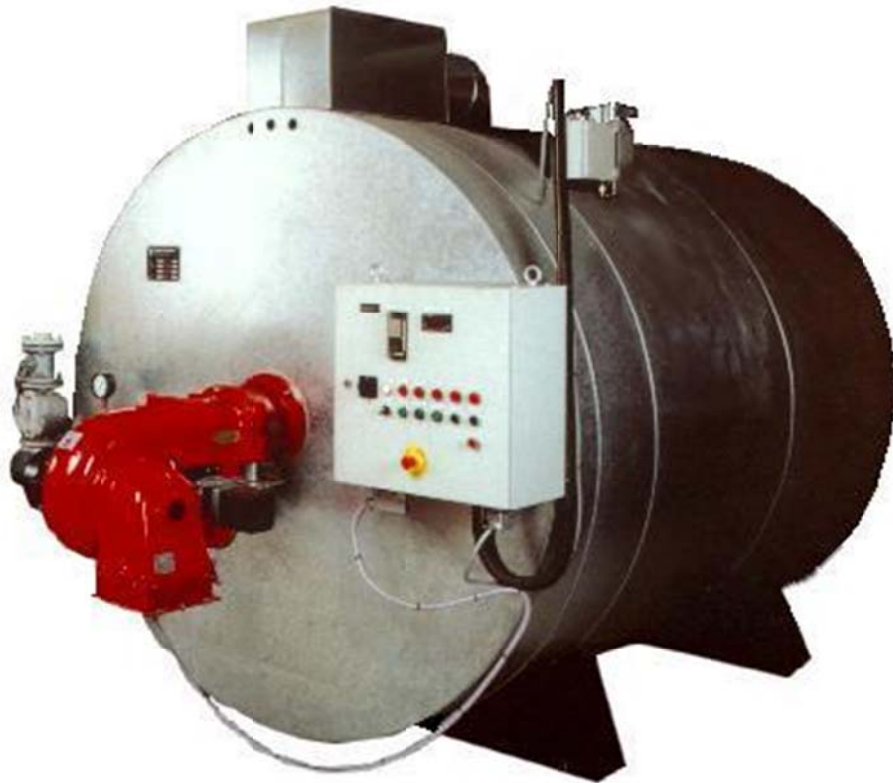

If there is fire...



1. Exit the building as quickly as possible.



2. Crawl low in smoke.

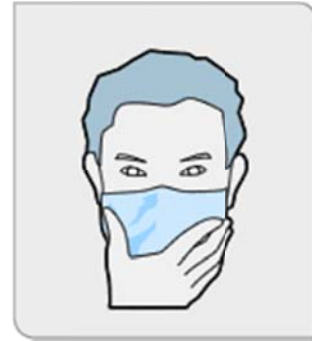

3. Use a wet cloth to cover your nose and mouth.



4. Use the back of your hand to feel the lower, middle, and upper parts of closed doors.



5. If the door is not hot, brace yourself against the door and open it slowly.

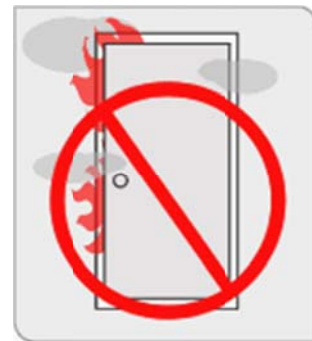

6. Do not open the door if it is hot. Look for another way out.



7. Use appropriate fire exits, not elevators.



8. If you get caught in fire, do not run!



9. Stop, Drop and Roll.

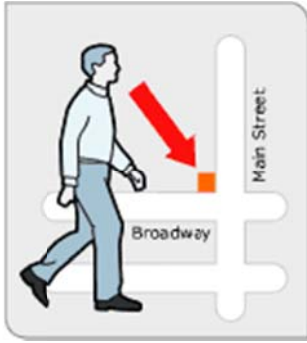

10. If you are at home, go to previously designated meeting place.



11. Account for your family members.



12. Do not go back into a burning building and carefully supervise small children.

If there is fire...



13. Call the fire department.

Chemical Attack

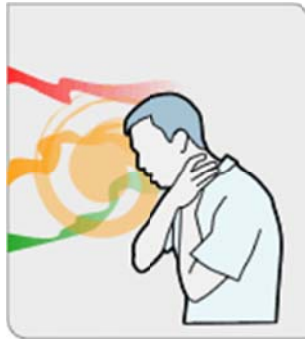
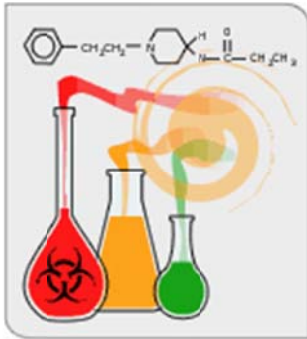

1. A chemical attack is the deliberate release of a toxic gas, liquid or solid that can poison people and the environment.
2. Watch for signs such as many people suffering from watery eyes, twitching, choking, having trouble breathing or losing coordination.
3. Many sick or dead birds, fish or small animals are also cause for suspicion.



4. If you see signs of a chemical attack, quickly try to define the impacted area or where the chemical is coming from, if possible.
5. Take immediate action to get away from any sign of a chemical attack.
6. If the chemical is inside a building where you are, try to get out of the building without passing through the contaminated area, if possible.



7. Otherwise, it may be better to move as far away from where you suspect the chemical release is and "shelter-in-place."

8. If you are outside when you see signs of a chemical attack, you must quickly decide the fastest way to get away from the chemical threat.

9. Consider if you can get out of the area or if it would be better to go inside a building and follow your plan to "shelter-in-place."



10. If your eyes are watering, your skin is stinging, you are having trouble breathing or you simply think you may have been exposed to a chemical, immediately strip and wash. Look for a hose, fountain, or any source of water.

11. Wash with soap and water, if possible, but do not scrub the chemical into your skin.

12. Seek emergency medical attention.

Biological Attack

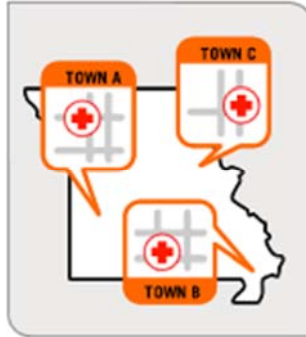
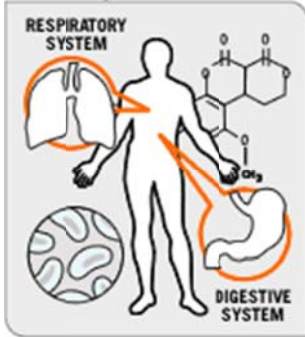

1. A biological attack is the release of germs or other biological substances. Many agents must be inhaled, enter through a cut in the skin or be eaten to make you sick. Some biological agents can cause contagious diseases, others do not.
2. A biological attack may or may not be immediately obvious. While it is possible that you will see signs of a biological attack it is perhaps more likely that local health care workers will report a pattern of unusual illness.
3. You will probably learn of the danger through an emergency radio or TV broadcast.



4. If you become aware of an unusual or suspicious release of an unknown substance nearby, it doesn't hurt to protect yourself.



5. Get away from the substance as quickly as possible.



6. Cover your mouth and nose with layers of fabric that can filter the air but still allow breathing.

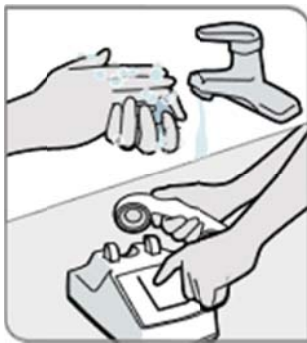

7. Wash with soap and water and contact authorities.



8. In the event of a biological attack, public health officials may not immediately be able to provide information on what you should do. However, you should watch TV, listen to the radio, or check the Internet for official news as it becomes available.



9. At the time of a declared biological emergency be suspicious, but do not automatically assume that any illness is the result of the attack. Symptoms of many common illnesses may overlap. Use common sense, practice good hygiene and cleanliness to avoid spreading germs, and seek medical advice.

If there is an explosion...



1. Take shelter against your desk or a sturdy table.



2. Exit the building as quickly as possible.



3. Do not use elevators.



4. Check for fire and other hazards.



5. Take your emergency kit if time allows.

Nuclear Blast



1. Take cover immediately, below ground if possible, though any shield or shelter will help protect you from the immediate effects of the blast and the pressure wave.
2. Consider if you can get out of the area;
3. Or if it would be better to go inside a building and follow your plan to "shelter-in-place".
4. In order to limit the amount of radiation you are exposed to, think about shielding, distance and time.



Shielding: If you have a thick shield between yourself and the radioactive materials more of the radiation will be absorbed, and you will be exposed to less.

Distance: The farther away from the blast and the fallout the lower your exposure.

Time: Minimize time spent exposed will also reduce your risk.

If you are trapped in debris...



1. If possible, use a flashlight to signal your location.



2. Avoid unnecessary movement so that you don't kick up dust.



3. Cover your mouth and nose with anything you have on hand. Dense weave cotton material can create a good filter. Try to breathe through the material.



4. Tap on a pipe or wall so that rescuers can hear where you are.



5. Use a whistle if one is available. Shout only as a last resort - shouting can cause a person to inhale dangerous amounts of dust.

FIRE INSPECTION REPORT

Business/Project Name:		Phone:		Occupancy:	
Business/Project Address:			City:	State:	ZIP:
Business / Property Representative:				Title:	
Insp. / Eng. Co.	Shift:	Date:	District / Plat:	Page	of

NOTICE OF FIRE & SAFETY HAZARDS: You are hereby notified that an inspection of your premises has disclosed the following fire / safety hazards and/or violations of the provisions of local and/or state codes.

TYPE OF INSPECTION:

- | | | | |
|--|--|---|---|
| <input type="checkbox"/> General Inspection | <input type="checkbox"/> Residential AS | <input type="checkbox"/> Single Family Resid. | <input type="checkbox"/> Construction up-date |
| <input type="checkbox"/> Reinspection | <input type="checkbox"/> Commercial AS | <input type="checkbox"/> Driveway / Access | <input type="checkbox"/> Special Hazard |
| <input type="checkbox"/> Code Complaint | <input type="checkbox"/> Fire Alarm System | <input type="checkbox"/> Brush / Weeds | <input type="checkbox"/> Temporary C/O |
| <input type="checkbox"/> Miscellaneous / Other | <input type="checkbox"/> Hood System | <input type="checkbox"/> Occupancy Inspection | <input type="checkbox"/> Final C/O |

ITEMS TO BE CORRECTED:

- | | | |
|--|--|---|
| <input type="checkbox"/> 1. Repair illuminated exits signs | <input type="checkbox"/> 7. Storage 18" of sprinkler heads | <input type="checkbox"/> 13. Secure gas cylinders |
| <input type="checkbox"/> 2. Repair emergency lights | <input type="checkbox"/> 8. Service, test or repair AS system | <input type="checkbox"/> 14. Remove extension cords |
| <input type="checkbox"/> 3. Exits unlocked at business hours | <input type="checkbox"/> 9. Service, test or repair fire alarm | <input type="checkbox"/> 15. Maintain occupant load |
| <input type="checkbox"/> 4. Clear blocked exits & exit paths | <input type="checkbox"/> 10. Clean hood & flue system | <input type="checkbox"/> 16. Keep site accessible |
| <input type="checkbox"/> 5. Remove weeds/grass/debris | <input type="checkbox"/> 11. Service, test or repair hood system | <input type="checkbox"/> 17. Access to electrical service |
| <input type="checkbox"/> 6. Storage from concealed spaces | <input type="checkbox"/> 12. Service fire extinguisher(s) | <input type="checkbox"/> 18. Other |

ITEM #	DESCRIPTION / LOCATION	COMPLY BY	APPROVED

ORDER TO COMPLY: As the above-described conditions are contrary to law, you are hereby required to correct said conditions as indicated. This inspection is for your safety and the safety of your customers / clients. Your cooperation is appreciated.

COPY RECEIVED BY: _____ **DATE:** _____



We welcome you to complete the assignment in Microsoft Word. You can easily find the assignment at www.abctlc.com. Once complete, just simply fax or e-mail the answer key along with the registration page to us and allow two weeks for grading. Once we grade it, we will mail a certificate of completion to you. Call us if you need any help. If you need your certificate back within 48 hours, you may be asked to pay a rush service fee of \$50.00.

You can download the assignment in Microsoft Word from TLC's website under the Assignment Page. www.abctlc.com You will have 90 days in order to successfully complete this assignment with a score of 70% or better. If you need any assistance, please contact TLC's Student Services. Once you are finished, please mail, e-mail or fax your answer sheet along with your registration form.
