

Hazardous Area Classification



At the beginning, let's review some basic definitions



Hazard

Something with the potential to cause harm such as FIRE Hazard



Risk

The probability of that harm to occur and its consequences.



Fire & Explosion Fundamentals

Fire

A combustion reaction in which fuel is converted to combustion products in the presence of oxygen rapidly producing heat and light.

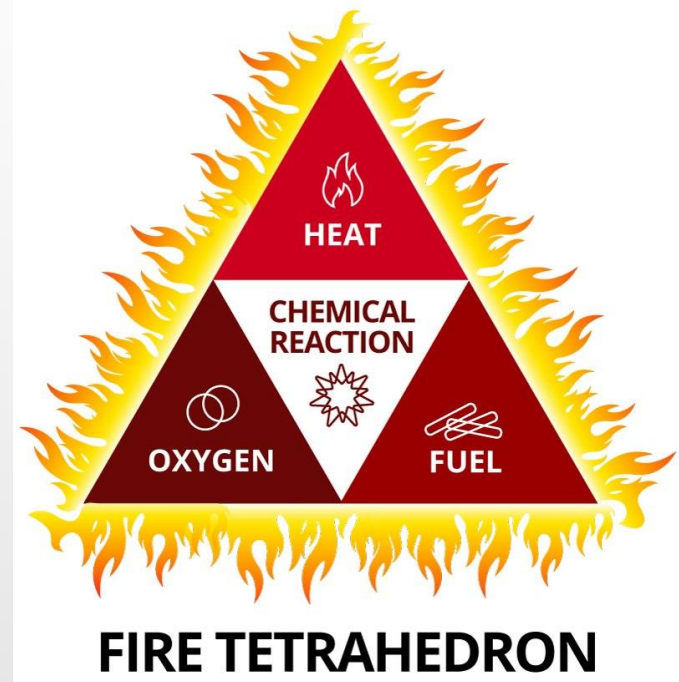

Explosion

A sudden release of energy causing a pressure blast wave.







Usually it is the result, not the cause, of a sudden release of gas under high pressure.



Ignition sources

- ❑ Open flames – matches, welding, etc.
- ❑ Electrical sparking.
- ❑ Spontaneous ignition.
- ❑ Static electricity.
- ❑ Hot surfaces.
- ❑ Smoking.



CLASSES OF FIRES	TYPES OF FIRES	SYMBOL
A	Wood, paper, fabric, plastic, and most kinds of trash.	
B	Flammable liquids (for example, gasoline).	
C	Burning gases (for example, natural gas).	
D	Combustible metals * such as magnesium, potassium, titanium, and zirconium. * Exception of the metals that burn in contact with air or water (for example, sodium).	
E	Fires involving potentially energized electrical equipment .	
F	Unsaturated cooking oils in well insulated cooking appliances located in commercial kitchens.	

The stages of combustion

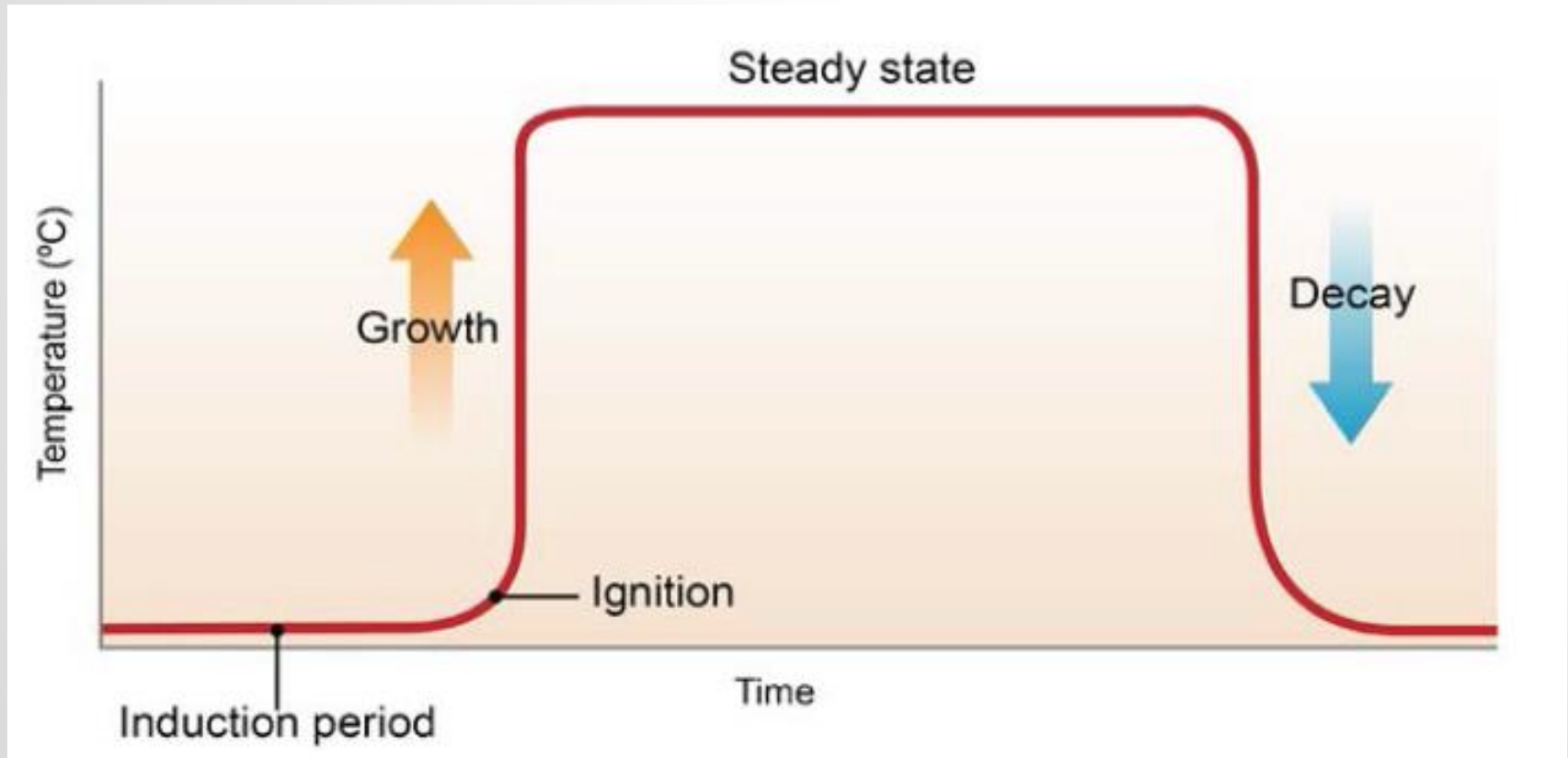

Flash Point

The lowest temperature of a liquid at which sufficient vapor is given off to ignite momentarily (flash), when an external source of ignition is applied.

Note the difference between Diesel & Petrol

Some common solvents and their flash points

Solvent	Flash Point (°C) (Abel closed cup)
Butanone (methyl ethyl ketone, MEK)	-7
Carbon disulphide (CS ₂)	-30 (Auto-ignition temp. 102°C)
Diesel oil	+40 (approx.)
Ethyl ethanoate (ethyl acetate)	-4
Ethoxyethane (diethyl ether)	-40
Methylated spirit	10
Methylbenzene (toluene)	4
Petrol	-40 (approx.)
Phenylethene (styrene)	32
Propanone (acetone)	-17

Fire Point

The lowest temperature of a liquid at which sufficient vapor is given off at the surface that the application of an external ignition source will lead to continuing burning.

The fire point temp. is usually just above the flash point.

Auto-Ignition temperature (AIT)

The lowest temperature at which the substance will ignite without the application of an external ignition source.

No requirement of external ignition source to achieve combustion as Methane gas has an auto-ignition temp. of 580 °C

Limits of Flammability



The extremes of fuel (vapor or gas) to air ratios between which the mixture is combustible

Examples of Flammable Limits

Fuel	Physical State	Lower % Limit	Upper % Limit
Hydrogen	Gas	4	74
Carbon monoxide		12.5	74
Methane		5	15
Propane		2.5	9.5
Butane		2	8.5
Ethylene (ethene)		3	32
Acetylene (ethyne)		2.5	80
Ethyl alcohol (ethanol)		Vapour from liquid	4
Carbon disulphide	1.3		50
Petrol	1.4		7.5
Paraffin	0.7		5.0
Diethyl ether (ethoxyethane)	2		36

How to prevent and mitigate Explosions?

- **V**entilation
- **I**gnition sources
- **C**ontainment
- **E**xchange
- **S**eparation

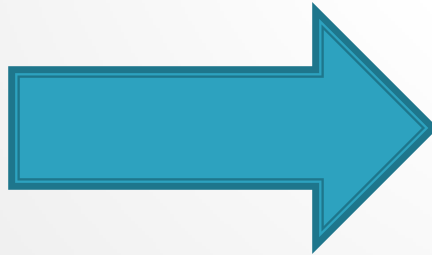

VICES

1. Ventilation

Ensure that any vapors given off from a spill, leak, or release from any process will be rapidly dispersed, preventing the formation of a vapor/air mixture above the LEL.



2. Ignition Sources

Ignition sources must be removed from storage and process areas of flammable materials. If the ignition source generates energy above the Minimum Ignition Energy (MIE) for the flammable vapor or gas an explosion will occur.



3. Containment

Prevents the escape of flammable materials into the workplace which can release vapors and generate explosive mixture.



4. Exchange

Exchange of a flammable substance for a less flammable one will reduce the risk of formation of an explosive atmosphere under normal working conditions.

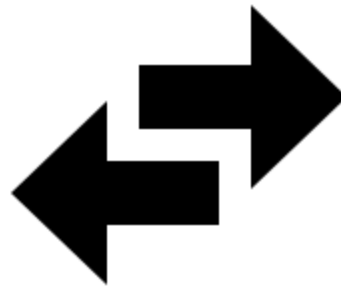

5. Separation

Separation of flammable substances from other processes and general storage areas by physical barriers, walls or partitions will contribute to a safer workplace by controlling the zone in which flammable atmosphere may be present.

Source of Release

A point from which a flammable gas, vapors or liquids may be released into atmosphere

Such as : flanges, vents, instrument connections...etc.

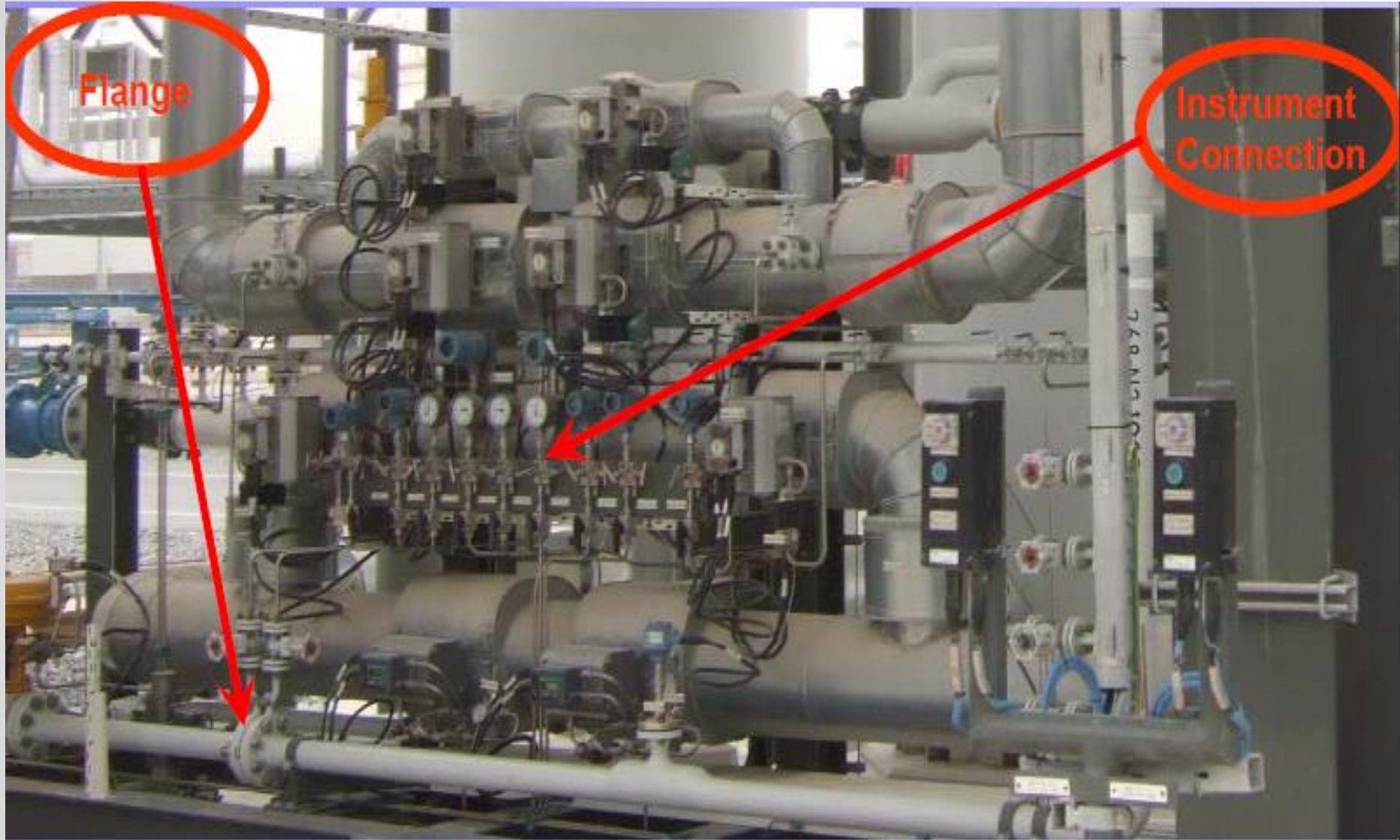

Ignition source

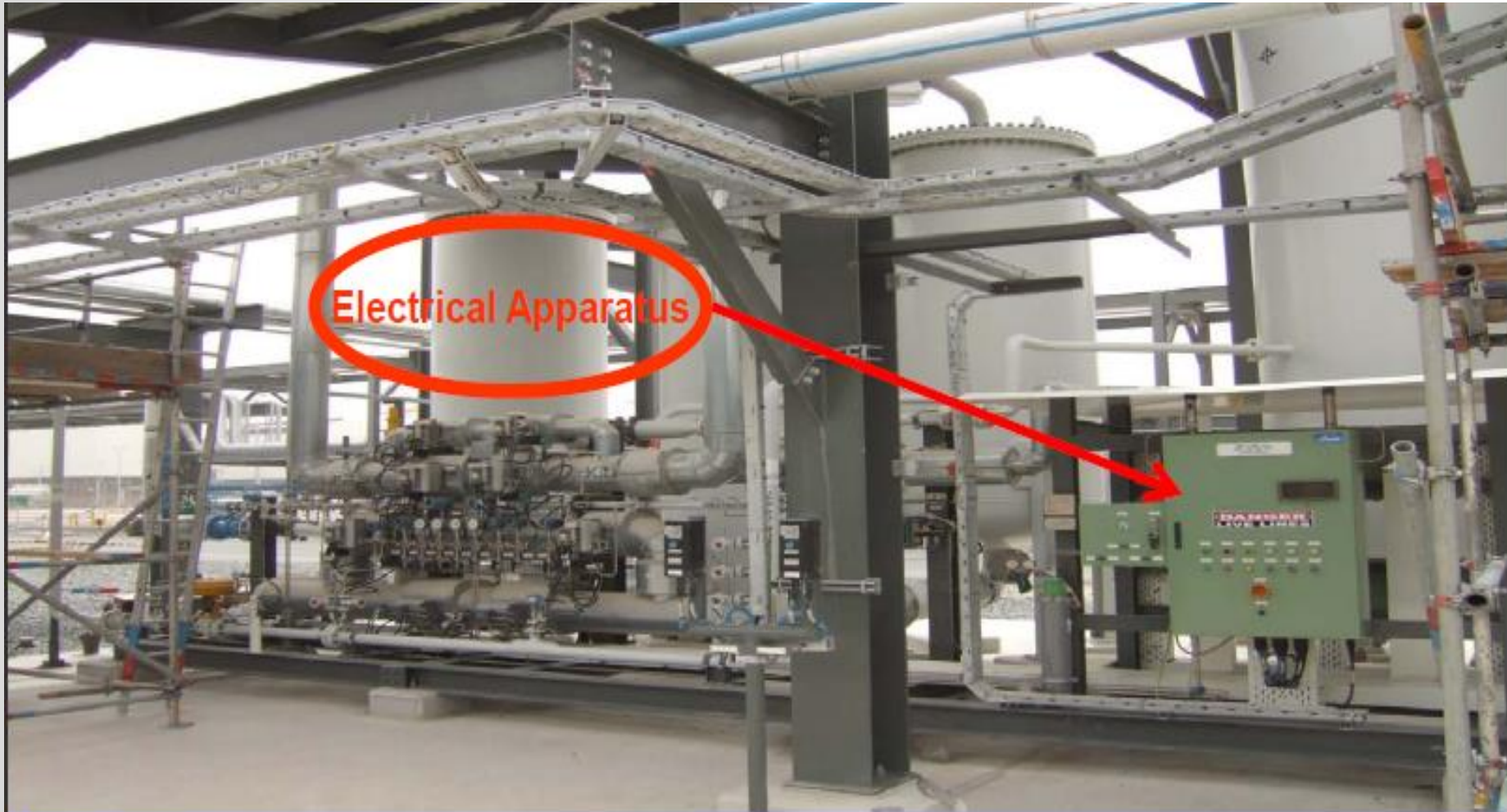

We have now source of release and source of ignition.

What is missing for a fire to occur ??



Aim of Area Classification

To avoid ignition of releases that may occur from time to time

The approach is to reduce (to an acceptable level) the probability of coincidence of a flammable atmosphere and an electrical or other source of ignition.

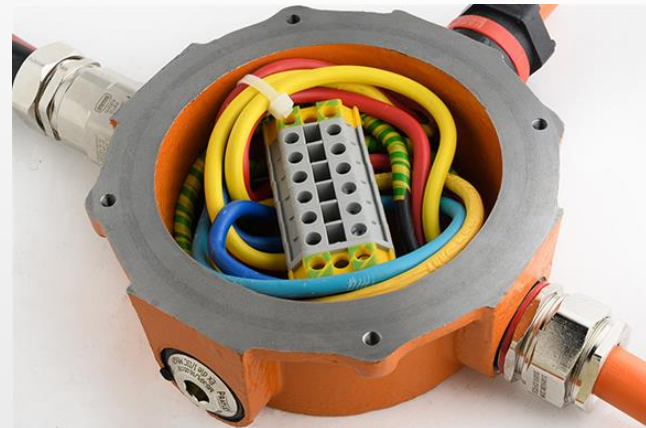

Hazardous Area

A three dimensional space in which a flammable atmosphere may be expected to be present at such frequencies as to require special precaution for the design and construction of equipment, and the control of potential ignition sources.

**Leak
source**

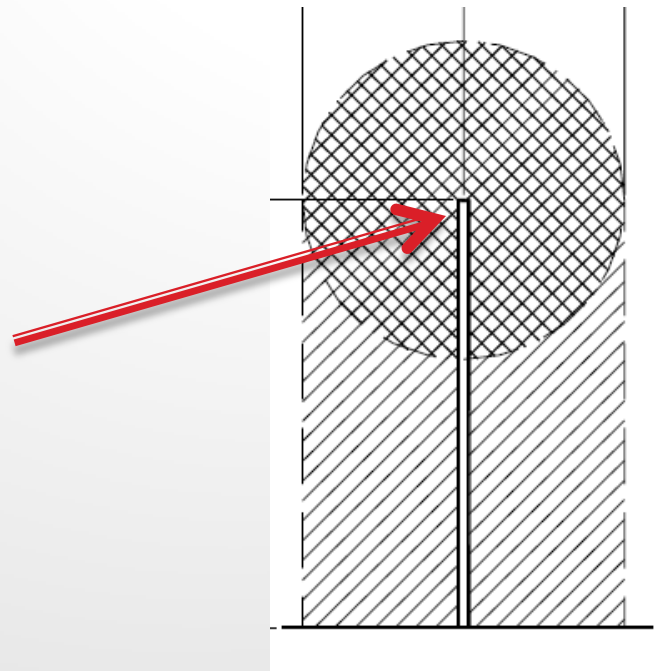

Where is the Leak & Ignition Sources here ?



Subdivisions of Hazardous Area

- The European classification

Zone 0 – Zone 1 – Zone 2

- The American classification

Division 1 – Division 2

- ❑ **Zone 0**: flammable atmosphere is **continuously** present or present for long periods.
- ❑ **Zone 1**: flammable atmosphere is **likely** to occur in normal operation.
- ❑ **Zone 2**: flammable atmosphere is **unlikely** to occur in normal operation and, if it occurs, will exist only for short period.

Grade of Release

- ❑ **Continuous**: A release that is **continuous** or nearly so.
- ❑ **Primary**: A release that is **likely** to occur periodically or occasionally in normal operation. (Vents, Sample points, etc)
- ❑ **Secondary**: A release that is **unlikely** to occur in normal operation and, in any event, will do so only infrequently and for short periods. (Flanges, Instrument connections, etc)

Zones and Divisions

Continuous Release	Primary Release	Secondary Release	Codes and Standards
Zone 0	Zone 1	Zone 2	IEC 60079, IP 15, API 505, NFPA 497
Division 1		Division 2	API 500, NEC Article 500, NFPA 497

Hazardous Location Types

	Example	NEC 500-503	NEC 505
CLASS I (Gases and Vapors)	Acetylene Hydrogen Ethylene Propane	Group A Group B Group C Group D	IIC IIC or IIB+H ₂ IIB IIA
CLASS II (Dusts)	Metal dust Coal dust Grain dust	Group E Group F Group G	
CLASS III (Fibers & Flying)	Wood, paper or cotton processing.	No sub-groups	

□ Class I

An area where Flammable Gases or Vapors are or can be present in the air in quantities sufficient to produce explosive or ignitable mixtures.

Examples : Petroleum Refineries, Gasoline storage and dispensing areas, Dry cleaning plants, Spray Finishing areas, utility gas plants.



□ Class II

An area where presence of Combustible Dust present a fire or explosion hazard.

For example:

Grain elevators, flour and feed mills, Use or store of magnesium or aluminum powders, producers of plastics, fireworks.



□ Class III

An area made hazardous due to the presence of easily Ignitable Fibers or flings.

For example:

Textile mills, cotton gins, cotton seed mills, plants that shape or cut wood and create sawdust or flings.



In addition to the types of hazardous locations, the kind of conditions under which these hazards are present are very important :

Normal Conditions & Abnormal Conditions

Division 1: Normal Conditions

Division 2 : Abnormal Conditions

Class I Division 1
II
III

1
2

Class I, Division 1

- ❑ Where ignitable concentration of flammable gases, vapors or liquids can exist all of the time or some of the time under normal operating conditions. (Remember Zone 0 & Zone 1)
- ❑ Where ignitable concentrations of such gases or vapors may exist frequently because of repair or maintenance operations or because of leakage.
- ❑ Faulty operations of equipment or processes might release ignitable concentrations of flammable gases or vapors and might cause simultaneous failure of electrical equipment in such a way as to directly cause the electrical equipment to become a source of ignition.

Class I, Division 2

Is a location in which volatile flammable liquids or flammable gases are handled, processed, or used, but in which the liquids, vapors, or gases will normally be confined within closed containers or closed systems from which they can escape only in case of accidental rupture or breakdown of such containers or systems or in case of abnormal operation of equipment.

Remember Grades of Release and Zone 2 definition

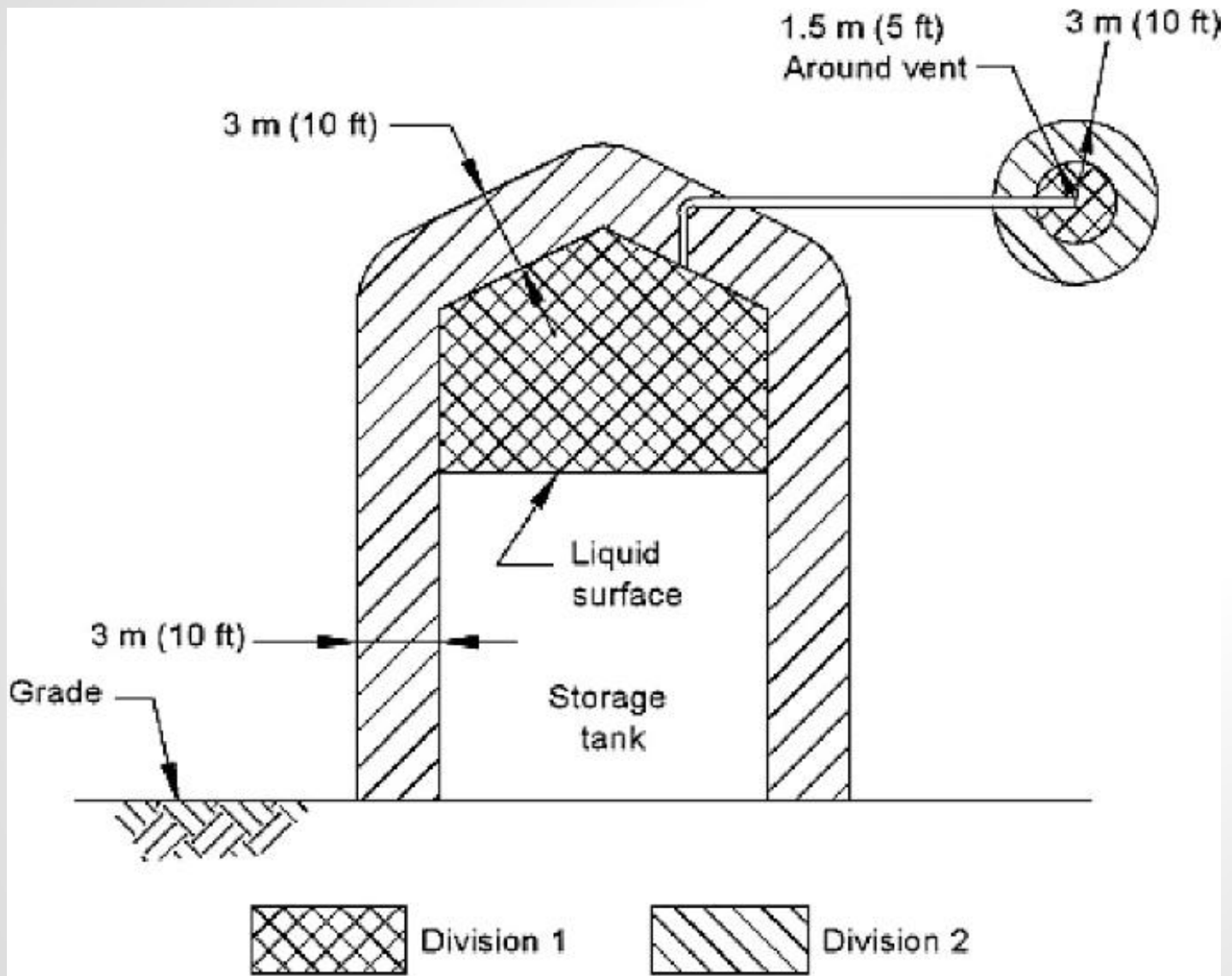

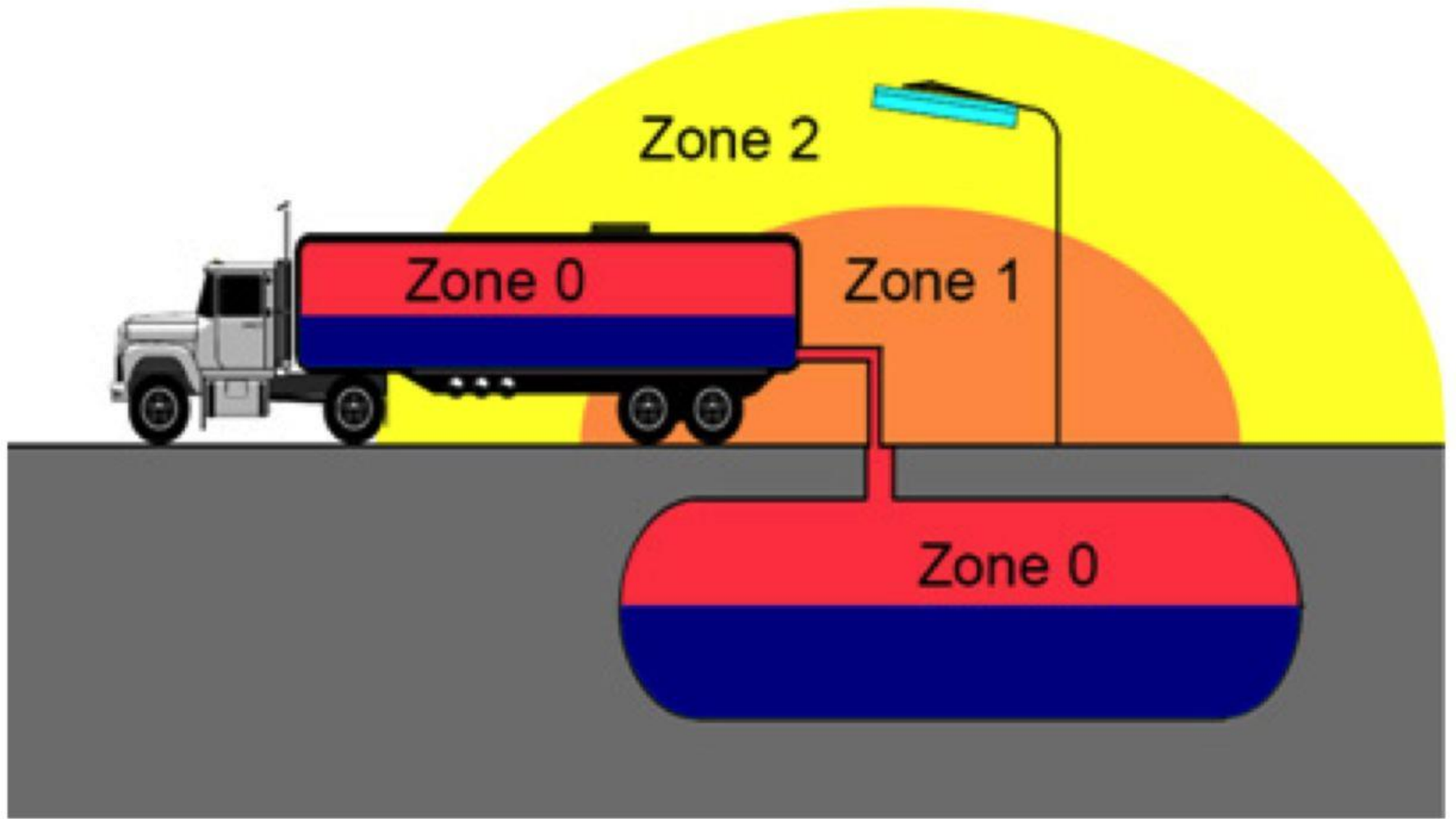

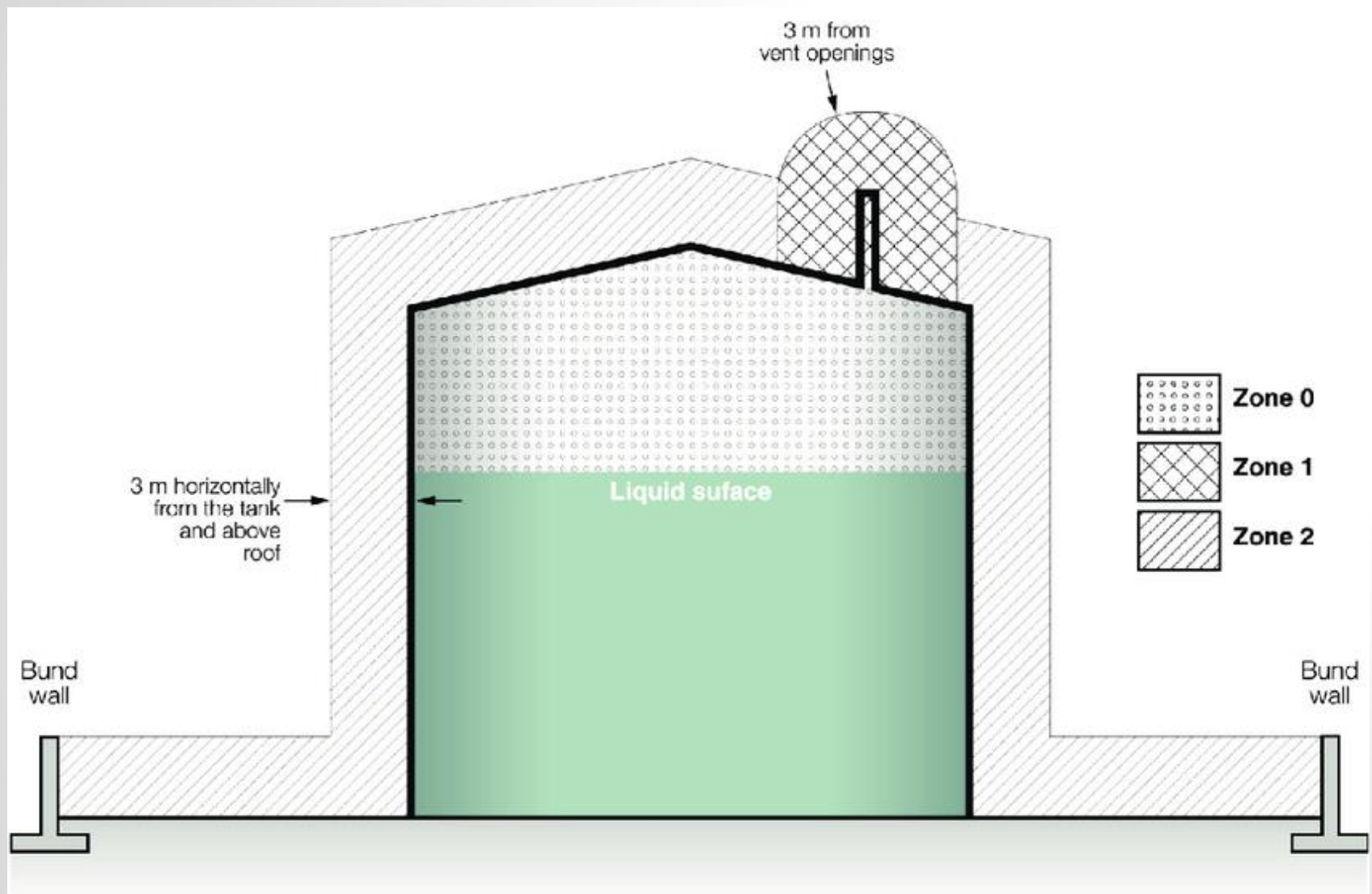



□ Gas Grouping

The gases and vapors of class I locations are broken into four groups : A, B, C, and D.

These materials are grouped according to the ignition temperature of the substance, its explosion pressure, and other flammable characteristics.

Typical Gas Hazard	NEC Article 500	IEC
Acetylene	A	IIC
Hydrogen	B	IIC
Ethylene	C	IIB
Propane	D	IIA

Group A

An atmosphere containing **Acetylene**.

Group B

Atmosphere containing a flammable gas, a flammable liquid produced vapor, or a combustible liquid produced vapor mixed with air that may burn or explode, such as **Hydrogen** or fuel and combustible process gases containing more than 30% hydrogen by volume – or gases of equivalent hazard such as butadiene, ethylene oxide.

Group C

Atmosphere containing a flammable gas, a flammable liquid produced vapor or a combustible liquid such as carbon monoxide, ether, hydrogen sulfide, Morphine, cyclopropane, ethyl, isoprene, Acetaldehyde and ethylene or gases of equivalent hazard.

Group D

Atmosphere containing flammable gas, flammable liquid produced vapor, or combustible liquid produced vapor mixed with air that may burn or explode, such as gasoline, acetone, ammonia, benzene, butane, ethanol, hexane, methanol, methane, vinyl chloride, natural gas, naphtha, propane or gases of equivalent hazard

□ Temperature Class

- It is important to know how hot equipment gets, so that hot surfaces cannot be ignition sources.
- Six temperature classes are used T1 - T6
- The lower the number the higher the maximum allowable surface temperature
- Temperature classification is based on fault conditions.
- T-class must be below Auto-ignition Temperature of the gas.

□ Auto-Ignition Temperature (AIT)

Temperature Class is assigned to flammable material based on its auto-ignition temperature. **(Remember the definition)**

Temperature Class	Auto-ignition Temperature (°C)
T1	>450
T2	>300
T3	>200
T4	>135
T5	>100
T6	>85

Material	AIT (° C)	Temperature Class
Methane	595	T1
Ethane	515	T1
Propane	470	T1
Butane	365	T2
Pentane	285	T3

Selection of Electrical Equipment in Hazardous Areas



□ Factors to be considered

- 1– **Zone** in which the equipment will be used.
- 2– Sensitivity to ignition of the material likely to be present, expressed as a **gas group**.
- 3– Sensitivity of the material present to ignition by hot surfaces, expressed as a **temperature class**.

1. Selection According to Zone Classification

- ❑ Equipment suitable for Zone 0 can be used in Zones 0, 1 or 2.
- ❑ Equipment suitable for Zone 1 can be used in Zones 1 or 2.
- ❑ Equipment suitable for Zone 2 can be used only in Zone 2.

2. Selection According to Gas Groups



- ❑ Grouping becomes more severe in going from IIA to IIB to IIC.
- ❑ Group IIB equipment may be used in place of Group IIA equipment.
- ❑ Group IIC equipment can be used in place of equipment for both Group IIA and IIB.

3. Selection According to Temperature Class

Temperature Class	Maximum Surface Temperature (° C)
T1	450
T2	300
T3	200
T4	135
T5	100
T6	85

Types Of Protection



Country/Region	Standard & Marking	Description
North America		<p>For North America hazardous locations, equipment certification are performed by nationally recognized laboratories UL, MET, FM and CSA. In addition, the American National Standard Institute coordinates US standard to be used internationally and allow equipment to be used globally.</p>
Europe		<p>This standard is in accordance with EU directives; EN 60079 and 61241 specifically cover explosion protection. The CE along with Ex mark follows indications of the group and category. Also, if Group II equipment relates to the gases (G) or dust (D)</p>
International		<p>This standard addresses "Hazardous Locations", "Hazardous Area", and "Explosive Atmosphere". Places where flammable liquids, vapors, gases or combustible dusts along with sufficient quantities to cause fire or explosion.</p>

- 1. Flameproof Enclosures “d”**
- 2. Intrinsic Safety “i”**
- 3. Increased Safety “e”**
- 4. Powder/Sand Filled “q”**
- 5. Pressurized Apparatus “p”**
- 6. Oil Immersion “o”**
- 7. Special Protection “s”**
- 8. Encapsulation “m”**
- 9. Type of protection N “N”**

1. Flameproof Enclosures “d”

Type of protection, for which the parts which can ignite an explosive atmosphere are inside an enclosure which will

Withstand the pressure of the Explosion within the enclosure.

Prevent the transmission of the Explosion to an explosive Atmosphere surrounding the Enclosure.



2. Intrinsic Safety “i”

Type of protection, for which the energy in the electrical circuit is held so low that sparks, arcs or temperatures capable of causing ignition cannot occur.

Includes sub-division into the categories **ia** & **ib**

ia must not produce any ignition when any combination of two faults is present.

ib must not produce any ignition, in normal operation, when one fault is present.

3. Increased Safety “e”

Type of protection, for which measures are taken to prevent the possibility of non-permissible high temperatures and the formation of sparks or arcs on inner or outer parts of electrical apparatus, on which these do not occur in normal operation, with an increased level of safety.

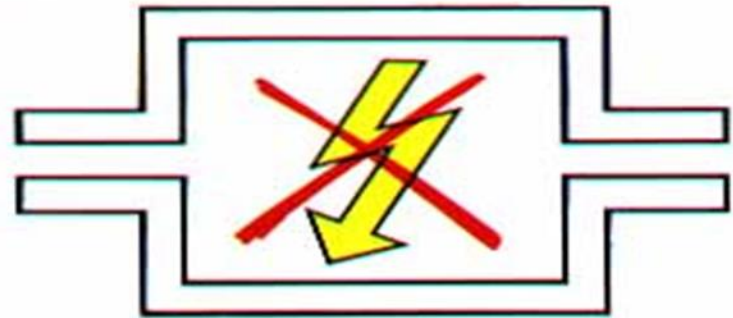

4. Powder/Sand Filled “q”

- ❑ The electrical apparatus enclosure is filled with powder or sand.
- ❑ An arc occurring in the enclosure does not ignite an explosive atmospheres surrounding the enclosure.



5. Pressurized Apparatus “p”

Preventing the entry of surrounding atmosphere into the enclosure by holding an ignition-protection gas (air, inert gas) under over-pressure in relation to the surrounding atmosphere.

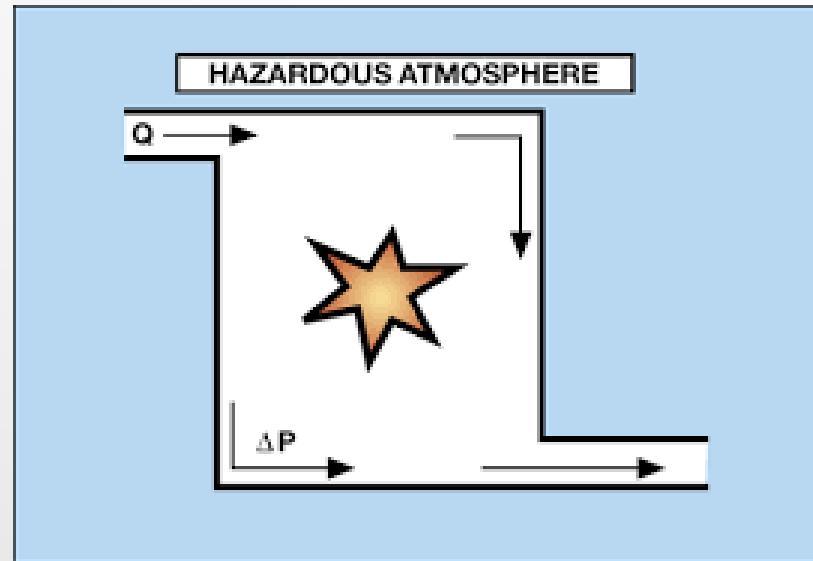

6. Oil Immersion “o”

Electrical apparatus or parts thereof are made safe by immersion in oil such that potentially explosive atmosphere above the surface of the oil or outside the enclosure will not be ignited.

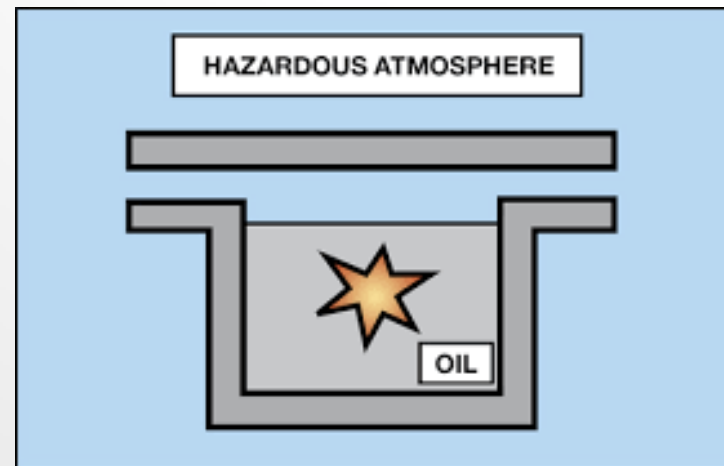

□ Ingress Protection (IP)





Ingress protection ratings or IP ratings, refer to the level of protection offered by an electrical enclosure, against solids and liquids.

In an environment where dust or water could damage electronic components, a sealed enclosure is used to prevent such ingress and safe house the electronics.



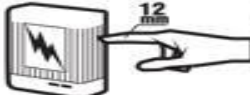
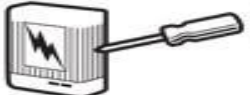

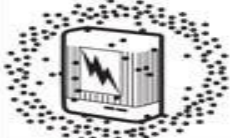



They are commonly used for applications which may be exposed to the elements, as well as dust or moisture. Typical industries include marine, offshore oil and gas platforms, lighting, food processing and more.

IP (Ingress Protection) Ratings Guide

SOLIDS

1		Protected against a solid object greater than 50 mm such as a hand.
2		Protected against a solid object greater than 12.5 mm such as a finger.
3		Protected against a solid object greater than 2.5 mm such as a screwdriver.
4		Protected against a solid object greater than 1 mm such as a wire.
5		Dust Protected. Limited ingress of dust permitted. Will not interfere with operation of the equipment. Two to eight hours.
6		Dust tight. No ingress of dust. Two to eight hours.

WATER

1		Protected against vertically falling drops of water. Limited ingress permitted.
2		Protected against vertically falling drops of water with enclosure tilted up to 15 degrees from the vertical. Limited ingress permitted.
3		Protected against sprays of water up to 60 degrees from the vertical. Limited ingress permitted for three minutes.
4		Protected against water splashed from all directions. Limited ingress permitted.
5		Protected against jets of water. Limited ingress permitted.
6		Water from heavy seas or water projected in powerful jets shall not enter the enclosure in harmful quantities.
7		Protection against the effects of immersion in water between 15 cm and 1 m for 30 minutes.
8		Protection against the effects of immersion in water under pressure for long periods.

Rating Example:

IP65

INGRESS PROTECTION

And now, How do you select an Electrical Equipment to install in Hazardous Area?



1. Identify the flammable materials.

Gas, Vapors, Dusts.....??

Hydrogen, LPG, Gasoline ??

2. Identify Sources of Release

Identify sources of release and determine grade of release.

and hence Zone 0 – Zone 1 – Zone 2 or Division 1, 2

3. Determine extent of hazardous area.

API RP 500 shows typical examples of classifications of equipment in oil and gas production facilities, including the extent of the classified areas around such equipment.

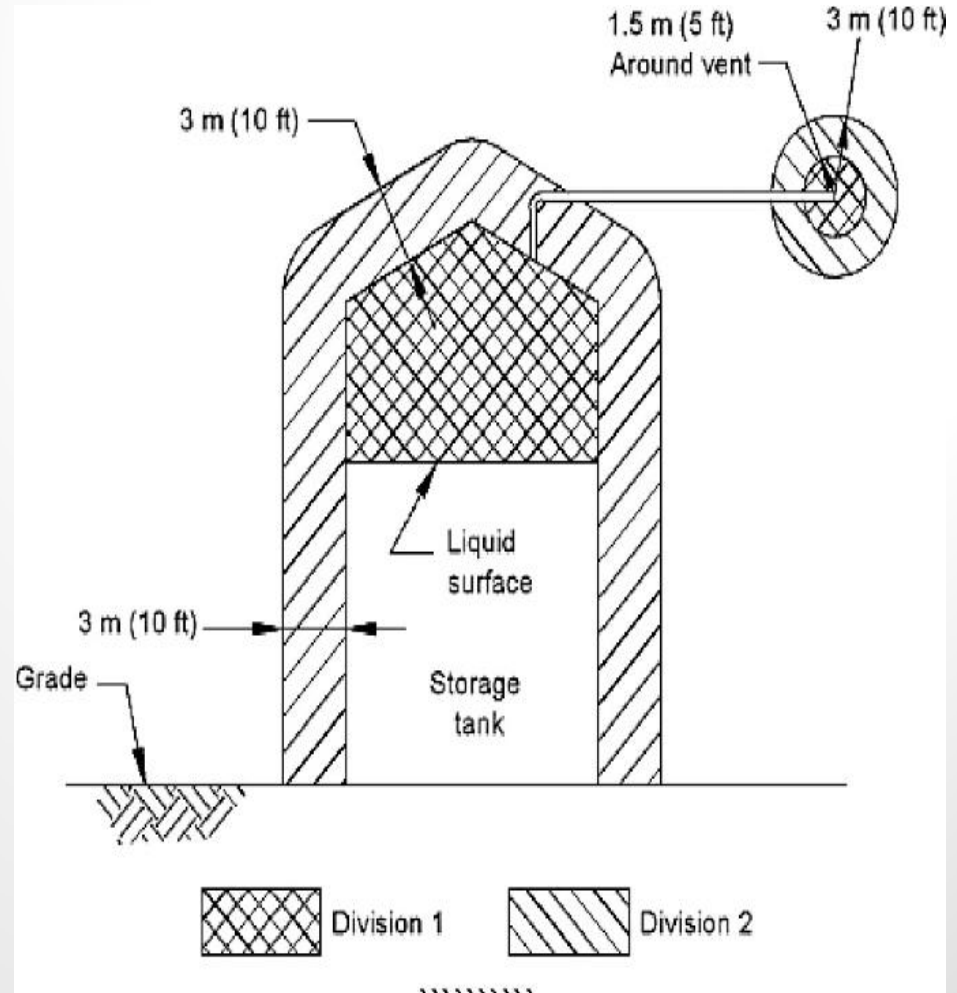

4. Assign Gas Groups and Temperature Class.

Gas Groups : A, B, C, D OR IIA, IIB, IIC

Temp. classes from T1 to T6

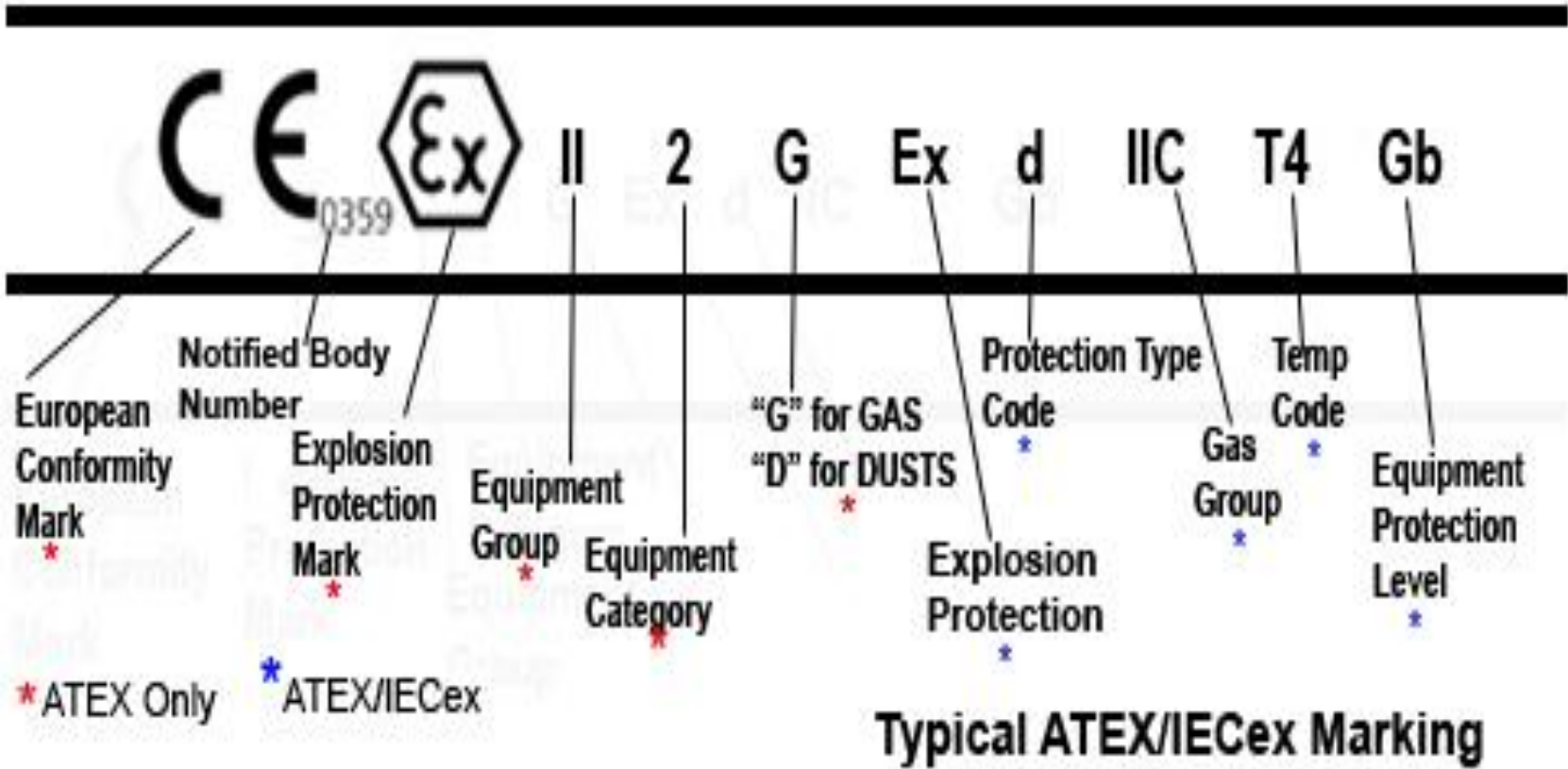

Group Quiz



1. The elements of Fire Triangle are

- A. Oxygen, Wood, CO₂
- B. Oxygen, Fuel, CO₂
- C. Oxygen, Fuel, Nitrogen
- D. Oxygen, Fuel, Heat

2. In the event of an uncontrolled fire in your vicinity, your first course of action should be to:

- A. Activate the Alarm
- B. Ask someone else what to do
- C. Run away as quickly as possible
- D. Get a fire extinguisher

3. To operate the fire extinguisher, the acronym P.A.S.S. is often used to help us remember to _____.

- A. Pass by the fire, activate the sprinkler system, seal fire area from oxygen, stop unauthorized entry.
- B. Pull the alarm, alert the response team, shut down the power sources, secure the area.
- C. Pass by the fire, activate the fire alarm, select the proper extinguisher, shoot at the base of the fire.
- D. Pull the pin, aim at the base of the fire, squeeze the handle, and sweep at the base of the fire.

4. A Powder Extinguisher can be used on which types of fires:

- A. Class A (solid materials like wood, paper, textiles)
- B. Class B (liquids like petrol, diesel or oils)
- C. Class C (gasses)
- D. All the above

5. The lowest temperature of a liquid at which sufficient vapor is given off to ignite momentarily , when an external source of ignition is applied is:

- a. Boiling Point.
- b. Auto Ignition Temperature.
- c. Flash Point.
- d. Fire Point.

6. Areas defined as “Hazardous” will:

- a. Be documented
- b. Documentation will be available
- c. Classification under supervision of qualified registered engineer
- d. All the above

7. Areas where flammable gases or vapors are or may be present in the air in sufficient quantities to be explosive or ignitable are classified as:

- a. Class I
- b. Class II
- c. Class III
- d. Hazardous

8. Areas that are considered hazardous because of the presence of combustible fibers are classified as:

- a. Class 1
- b. Class 11
- c. Class 111
- d. Hazardous

9. Equipment shall be approved not only for the class of location, but also for the ignitable or combustible properties of the specific gas, vapor, dust, or fiber that will be present. This statement is:

- a. True
- b. False

10. What classification would be used at locations where volatile flammable liquids or flammable gases or vapors are used, but which would become hazardous only in case of an accident or of some unusual operating condition.

- a. Class I, Division 1
- b. Class II
- c. This is not considered a hazardous location
- d. Class I, Division 2

11. A facility may contain multiple classifications in various parts of a building. For example the storage room may be classified as Class III and a production area may be classified as a Class 1 Location. This statement is :

- a. True
- b. False

12. Equipment, wiring methods, and installations of equipment in hazardous (classified) locations shall be:

- a. intrinsically safe
- b. approved or safe for the hazardous (classified) location
- c. waterproof
- d. Both a and b

13. In which zone a flammable atmosphere is present continuously for a long time ?

- a. Zone 0
- b. Zone 1
- C. Zone 2
- d. Zone 3

Thank
you



