

**“TAKING PRESSURE VESSELS FROM CRADLE TO GRAVE”
SEMINAR**

**INSPECTION
OF
PRESSURE VESSELS
TO
Section VIII Div. 1**





Presentation Outline

- **What is Authorized Inspection?**
- **Overview of ASME Codes**
- **Code Stamps**
- **Inspection responsibilities: Manufacturer & Authorized Inspector**
- **ASME Section VIII: Scope & organization**
- **Section VIII Division 1 Inspection requirements**
- **Question & Answers**

What is Authorized Inspection?

ASME

- Develop Codes
- Accreditation of AIAs
- Issue Certificates of Authorization
- Conducts Joint Review
- Conducts Investigations

ABSG Consulting Inc

AUTHORIZED INSPECTION AGENCY

- Writes Boiler & PV Insurance
- Employs & Designates Inspectors
- Employs & Designates Supervisors
- Provide Support for Field Activities
- Certify ASME Data Reports

Jurisdiction

- Adopts Code
- Enforces ASME Code
- Function as AIA
- Conduct Joint Reviews
- Conduct Investigations

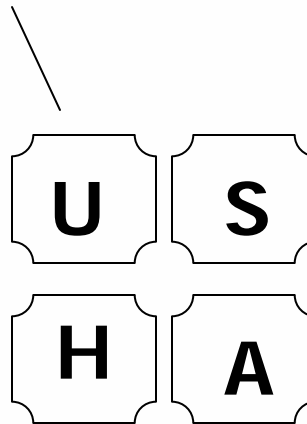

FABRICATORS

- Agreement with AIA
- Q.C. Program/ Manual
- Certificate of Authorization
- Comply with Code
- Certify ASME Data Reports
- Register Items with The National Board

National Board

- Commission Authorized Inspectors
- Register Data Reports
- Conduct Joint Reviews
- Conduct Investigations
- Issues The NBIC
- "R" Stamp Program

Hierarchy of Standards

- Laws and Regulations at the place of Installation
(e.g. Minnesota, New York City, Quebec...)
- ASME - Boiler & Pressure Vessel Code

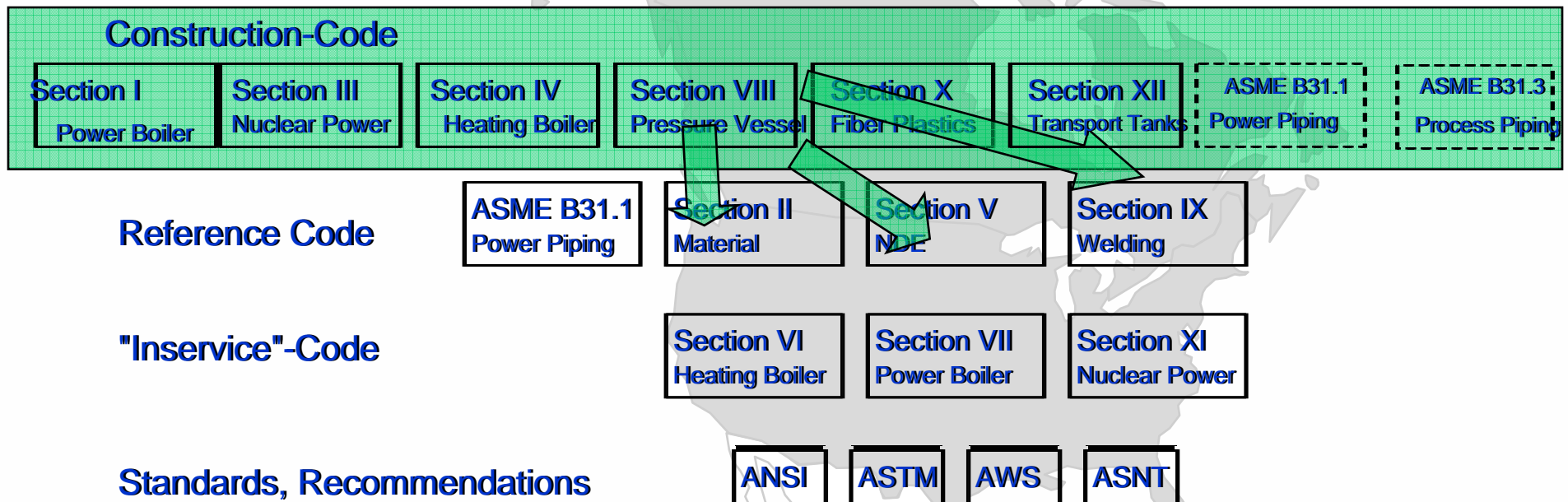

- National Board Inspection Code NBIC



Brief History of ASME

- 1911 - ASME set up the B&PV Committee - to formulate std rules for construction of boilers and pressure vessels
- 1915 - first Code issued - ASME 1 - Power Boilers
- 1923 - Heating Boilers - Section IV
- 1924 - Materials - Section II
- 1925 - Pressure Vessels - Section VIII Div 1
- 1941 - Welding & Brazing - Section IX
- 1963 - Nuclear Codes - Section III
- 1968 - Pressure Vessels - Section VIII Div 2
- 1971 - NDE - Section V
- 1997 - Pressure Vessels - Section VIII Div 3



INTRODUCTION

- ASME establishes rules for new construction of pressure vessels that will perform in a safe & reliable manner.
- ASME also interprets these rules when questions arise regarding their intent
- Code does not address all aspects and those not addressed should not be considered prohibited.
- Code does not fully address tolerances.
- Code is not a design handbook, designer must use engineering judgement consistent with Code philosophy which do not overrule mandatory requirements of the Code.



ASME CODE

Editions: Every 3 years new issuance (2004, 2007, 2010...)

Addenda: Issuance every year.
Replacement page format (coloured).
Mandatory 6 months after issuance.

Interpretations: Issued by ASME Code committees upon request.
Not part of the Code.

Code Cases: Formulated by the ASME Code Committee to clarify existing requirements or to provide rules not covered by the existing Code.

Errata: Are mandatory immediately

re-affirmed: referenced Codes & Standards
ASME B16.5 - E2003



ASME Code Manufacturer

- ASME Shop Approval is a prerequisite
- QC-System according to the ASME Code
- Audit by ASME, renewal every 3 years (U, U2)
- valid Inspection-Service-Agreement between Manufacturer and an AIA
- Authorized by ASME to use the Code Symbol Stamp(s).
- Certificate of Authorization, validity 3 years (U, U2)



Approvals

ASME shop approvals are not required for:

- Material Manufacturers (except Section III)
- Manufacturers of Welding Consumables (except Section III)
- Valve Manufacturers (except Section III and Safety Valves)
- Suppliers of Services (Design, Heat Treatment, Machining)
- Piping Manufacturers (except Section III)



Procedure of ASME Authorization

- Obtain Application Forms from ASME:

http://www.asme.org/Codes/CertifAccred/Certification/Application_Forms_2.cfm

- Submit Application Forms to ASME and remit Fees
- Purchase ASME Code Books
- Describe a QC-System according ASME Code
- Prepare a Demonstration Item
- Qualify Procedures and Personnel
- Pre-Joint Review by the Supervisor of AIA
- Joint Review (Audit) with ASME Designee, Inspector und Supervisor
- Issuance of Certificate and Stamp by ASME

ASME Boiler & Pressure Vessel Code

Section I - Steam Boilers

S	steam boilers (master)
A	assembly only
E	electric boilers
M	miniature boilers
PP	power piping (B31.1)
V *	safety valves

Section IV - Heating Boilers

H *	cast iron heating boilers
H	wrought steel heating boilers
HLW	potable water heaters
HV *	safety valves

National Board Inspection Code

R	repair and alteration
VR*	repair of safety valves

Section VIII Div. 1 - Pressure Vessels

U	pressure vessels
UM *	miniature vessels
UV *	safety valves
UD *	rupture disk devices

Section VIII Div. 2 - Alternative Rules

U2	pressure vessels
----	------------------

Section VIII Div. 3

U3	High Pressure Vessels
UV3*	safety valves

Section X - Fibre reinforced Plastic Pressure Vessels

RP	pressure vessels
----	------------------

Section XII - Transport Tanks

T	Transport tanks
TV*	safety valves
TD*	rupture disk devices

** Components not subject to Authorized Inspection, ASME Audit of the Manufacturer*



Responsibilities U-2, UG-90

Manufacturer's Responsibilities

- comply with all of the applicable requirements of the Code.
- assure that all work done by others also complies.
- have design calculation available.
- assure that QC is performed.
- assure that examinations are performed as required by the Code.
- arrange Inspection and free access of the Inspector.



Authorized Inspector Responsibilities U-2(e)

- To make all of the inspections specified by the rules of this Division
- Monitoring the quality control and the examinations made by the Manufacturer.
- Make such other inspections as in his judgment are necessary to permit him to certify that the vessel has been designed and constructed in accordance with the requirements.
- Verifying that the applicable calculations have been made and are on file at Manufacturer's plant at the time the Data Report is signed.
- Any questions concerning the calculations raised by the Inspector must be resolved.



ASME Code Key Words

shall

mandatory rules

may not

prohibition

may

recommendations or

can

exemptions from prohibitions

should

recommendations



ASME CODE SEC VIII

Section VIII Division 1

- up to 3,000 psi (20 MPa)
- simple stress calculation formulas
- no stress analysis required
- widespread use for Pressure Vessels

Section VIII Division 2

- up to 10,000 psi (70 MPa)
- user specifies service conditions (**user's design specification - UDS**)
- UDS shall be certified by a **Registered Professional Engineer (RPE)**
- provisions for stress analysis, fatigue, creep, experimental analysis)
- reduced wall thickness
- larger extend of NDE
- higher design stress levels
- Registered Professional Engineer (RPE) shall certify **Design Report**

Section VIII Division 3

- over 10,000 psi
- stress analysis is mandatory
- consideration of prestressed components
- extensive mandatory NDE
- small range of permitted material
- two RPEs are required



ORGANIZATION OF SEC VIII DIV.1

Forword

Introduction: U-1, U-2, U-3, U-4

Subsection A: UG – General Requirements

Subsection B: Methods of Fabrication

UW – welded pressure vessels

UF – forged pressure vessels

UB – brazed pressure vessels

Subsection C: Classes of Material - Special Constructions

Materials:	UCS	-	Carbon and Low Alloy Steel
	UNF	-	Non ferrous Materials
	UHA	-	High Alloy Steel
	UCI	-	Cast Iron
	UCL	-	Cladding and Lining
	UCD	-	Cast Ductile Iron
	UHT	-	Ferritic Steels with Heat Treatment
	ULW	-	Layered Constructions
	ULT	-	Low Temperature Service
	UHX	-	Shell and Tube Heat Exchanger

Mandatory and Nonmandatory Appendices

Index

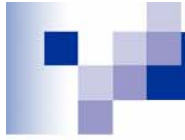

ASME VIII Div. 1

INSPECTION REQUIREMENTS



Inspection and Tests - Manufacturer

The inspection and testing shall conform to the general requirements in UG-90 & in addition, to the specific requirements for *Inspection and Tests* given in the applicable Parts of Subsections B and C.

- the drawings and design calculations for the vessel or part [10-5 and 10-15(d)];



Inspection and Tests - Manufacturer

- examination of all materials before fabrication to make certain they have the required thickness, to detect defects [UG-93(d)], to make certain the materials are permitted by this Division (UG 4), and that traceability (UG-77) to the material identification (UG-93) has been maintained
- identification for all material used in the fabrication of the vessel or part (UG-93); MTR's for plates
 - correct Material
 - visual Inspection for cracks specifically for impact tested material
 - Markings original/ transferred
 - securing Partial Data Reports [UG-120(c)]



Inspection and Tests - Manufacturer

- documentation of impact tests when such tests are required (UF-5, UCS-66, UHA-51, UHT-6, and ULT-5);
- concurrence of the Inspector prior to any base metal repairs (UG-78 and UF-37);
- examination of the shell and head sections to confirm they have been properly formed to the specified shapes within the permissible tolerances (UG-79, UG-80, UG-81, UF-27, and UF-29);



Forming Requirements



Plate Forming

UG-79 FORMING SHELL SECTIONS AND HEADS

(a) All plates for shell sections and for heads shall be formed to the required shape by any process that will not unduly impair the physical properties of the material. Limits are provided on cold working of all carbon and low alloy steels, nonferrous alloys, high alloy steels, and ferritic steels with tensile properties enhanced by heat treatment [see UCS-79(d), UHA-44(a)(1), UNF-79(a)(1), and UHT-79(a)].



UG-79 FORMING SHELL SECTIONS AND HEADS

(b) If the plates are to be rolled, the adjoining edges of longitudinal joints of cylindrical vessels shall first be shaped to the proper curvature by preliminary rolling or forming in order to avoid having objectionable flat spots along the completed joints (see UG-80).

(c) When the vessel shell section, heads, or other pressure boundary parts are cold formed by other than the manufacturer of the vessel, the required certification for the part shall indicate whether or not the part has been heat-treated (see UCS-79, UHA-44, UNF-79, and UHT-79).



Allowable Forming

- Code allows two types of forming:
 - Cold forming
 - Heating to shape
- Flat spots along the longitudinal joints must be avoided



Cold Forming

- Bumping to form the head dish
- Spinning to form the knuckle portion

Bumping



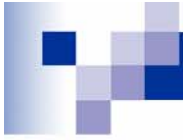

Head Measurement



Marking for Identification



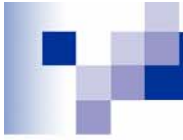

Head Spinning



Flange End Cutting



Hot Forming





Forming Carbon Steel

Additional requirements when forming carbon steel:

- Cold forming by blows is not permitted
- Forming by blows may be permitted when steel is at forging temperature provided the blows do not objectionably deform the plate and followed by PWHT
- Cold forming by those other than the Manufacturer requires a certification per UCS-79



Heat Treatment UCS-79

Requires material heat treatment when:

- Resulting fiber elongation is more than 5% from the as-rolled condition
- P-1 group 1 & 2 materials may have fiber elongation as great as 40%, provided none of the following conditions exist
 - Vessel is for lethal services
 - Material requires impact testing
 - Material thickness exceeds 5/8"
 - Reduction by cold forming from the as-rolled thickness is more than 10%
 - Temperature of the material during forming is 250 °F to 900 °F



UCS-79 – Fiber elongation

For double curvature (for example, heads),

$$\% \text{ extreme fiber elongation} = \frac{75t}{R_f} \left(1 - \frac{R_f}{R_o} \right)$$

For single curvature (for example, cylinders),

$$\% \text{ extreme fiber elongation} = \frac{50t}{R_f} \left(1 - \frac{R_f}{R_o} \right)$$

where

R_f = final centerline radius, in. (mm)

R_o = original centerline radius (equals infinity for flat plate), in. (mm)

t = plate thickness, in. (mm)



Interpretation: VIII-1-95-50

Subject: Section VIII, Division 1 (1992 Edition, 1993 Addenda); UCS-79(d)

Date Issued: March 13, 1995

Question (1): A cold formed head has to be heat treated to fulfill the requirements of UCS-79(d) in Section VIII, Division 1. Does the term “heat treated subsequently” mean just after forming and prior to any other operation?

Reply (1): No.

Question (2): If Reply (1) is no, then will PWHT in accordance with UCS-56 satisfy the requirements of UCS-79(d) following welding of the head to the vessel?

Reply (2): Yes.

FIG. 1-4 PRINCIPAL DIMENSIONS OF TYPICAL HEADS

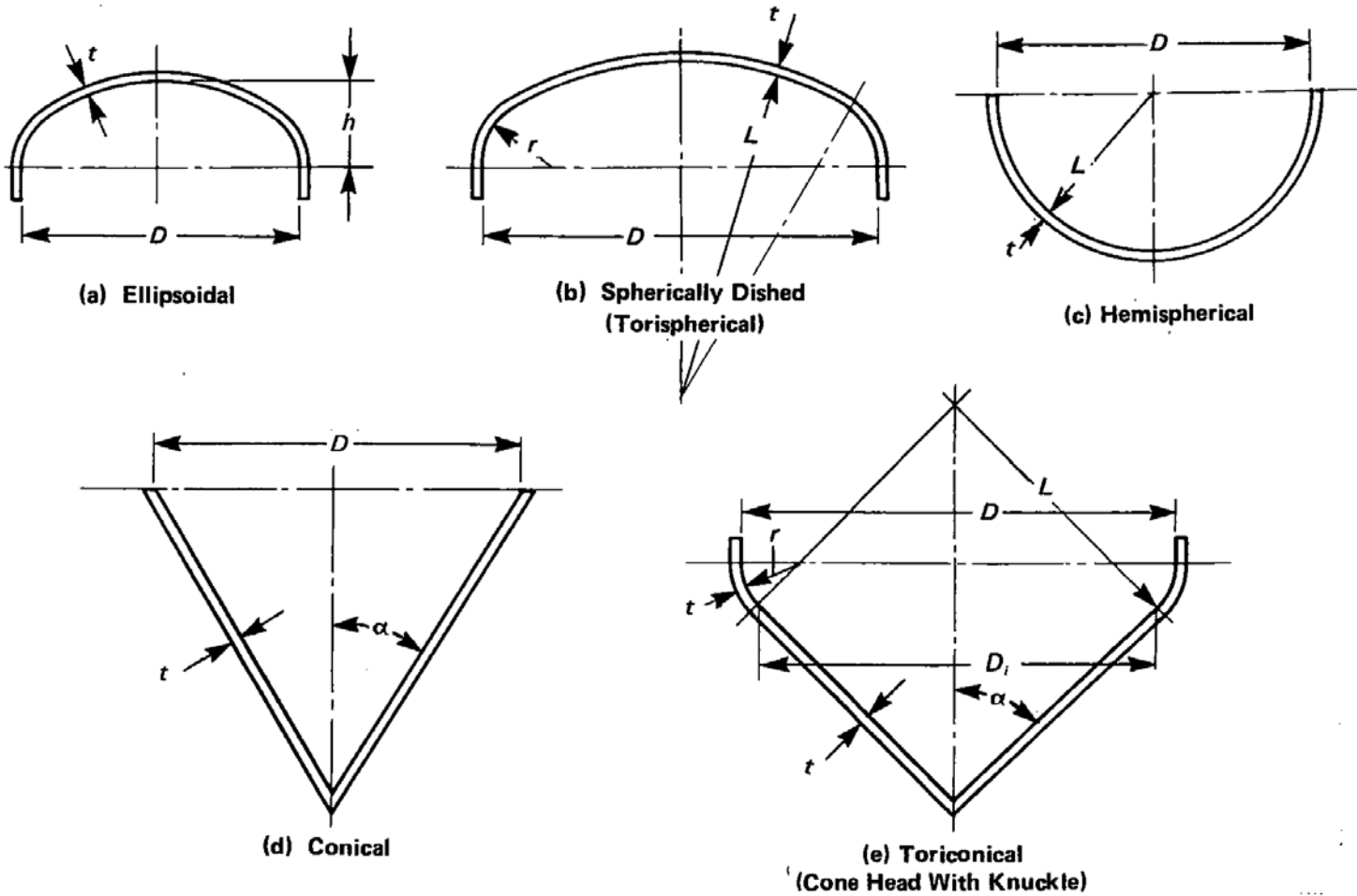

UG-80: Out-Of-Roundness

Internal Pressure

$$\frac{\text{Maximum ID} - \text{Minimum ID}}{\text{Nominal ID}} \times 100\% \leq 1\%$$

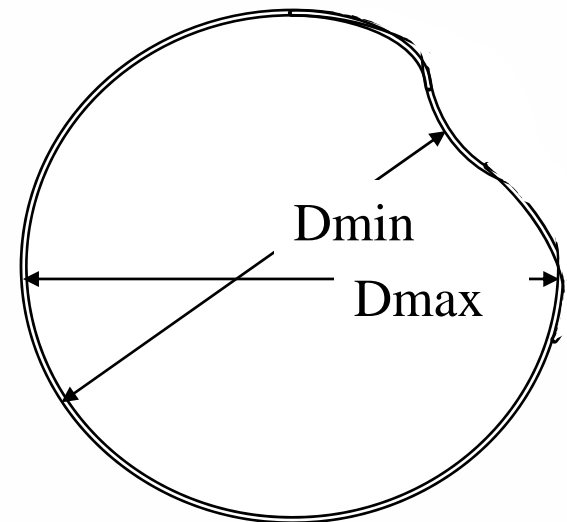
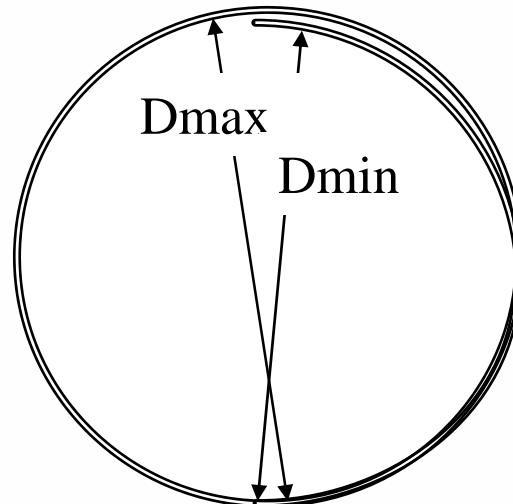
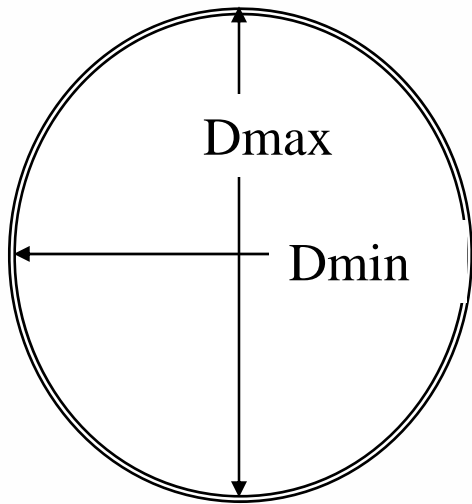



Out of Roundness – Internal Pressure

UG-80 PERMISSIBLE OUT-OF-ROUNDNESS OF CYLINDRICAL, CONICAL, AND SPHERICAL SHELLS

(a) Internal Pressure. The shell of a completed vessel shall be substantially round and shall meet the following requirements:

(1) The difference between the maximum and minimum inside diameters at any cross section shall not exceed 1% of the nominal diameter at the cross section under consideration. The diameters may be measured on the inside or outside of the vessel. If measured on the outside, the diameters shall be corrected for the plate thickness at the cross section under consideration (see Fig. UG-80.2).



Out of Roundness – Internal Pressure

(2) When the cross section passes through an opening or within 1 I.D. of the opening measured from the center of the opening, the permissible difference in inside diameters given above may be increased by 2% of the inside diameter of the opening. When the cross section passes through any other location normal to the axis of the vessel, including head-to-shell junctions, the difference in diameters shall not exceed 1%.



Out-of-Roundness

UG-80: External Pressure

- Must meet requirements for internal pressure
- Must meet requirements in Figure UG-80.1
- Measurement shall be made from a segmental circular template, having the design inside or outside radius and chord length equal to twice the arc length (Fig UG-29.2)



External Pressure

UG-80 PERMISSIBLE OUT-OF-ROUNDNESS OF CYLINDRICAL, CONICAL, AND SPHERICAL SHELLS

(2) The maximum plus-or-minus deviation from the true circular form, measured radially on the outside or inside of the vessel, shall not exceed the maximum permissible deviation e obtained from Fig. UG-80.1. Use $e = 1.0t$ or $e = 0.2t$, respectively, for points falling above or below these curves. Measurements shall be made from a segmental circular template having the design inside or outside radius (depending upon where the measurements are taken) and a chord length equal to twice the arc length obtained from Fig. UG-29.2. The values of L and D_o in

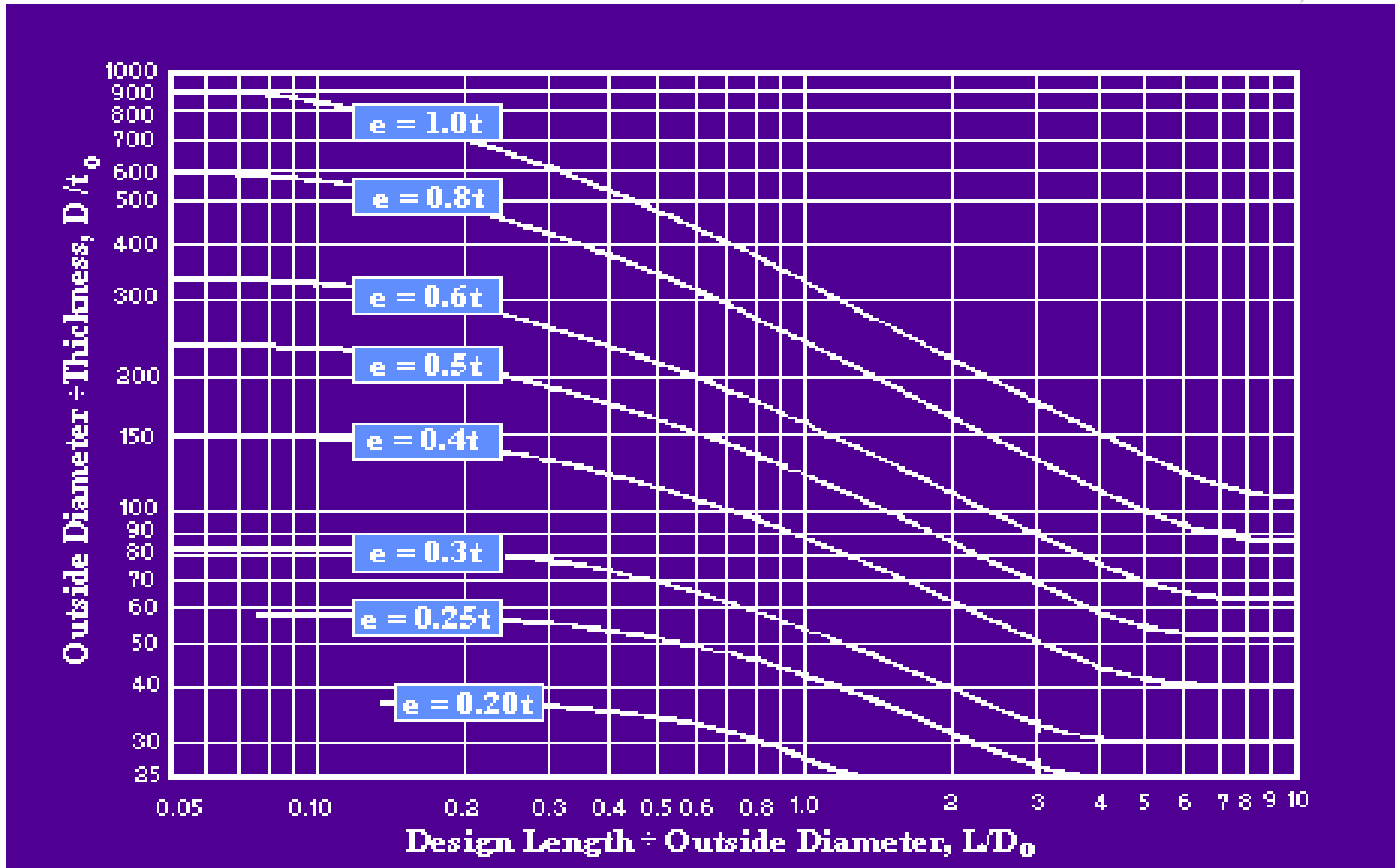
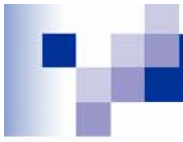
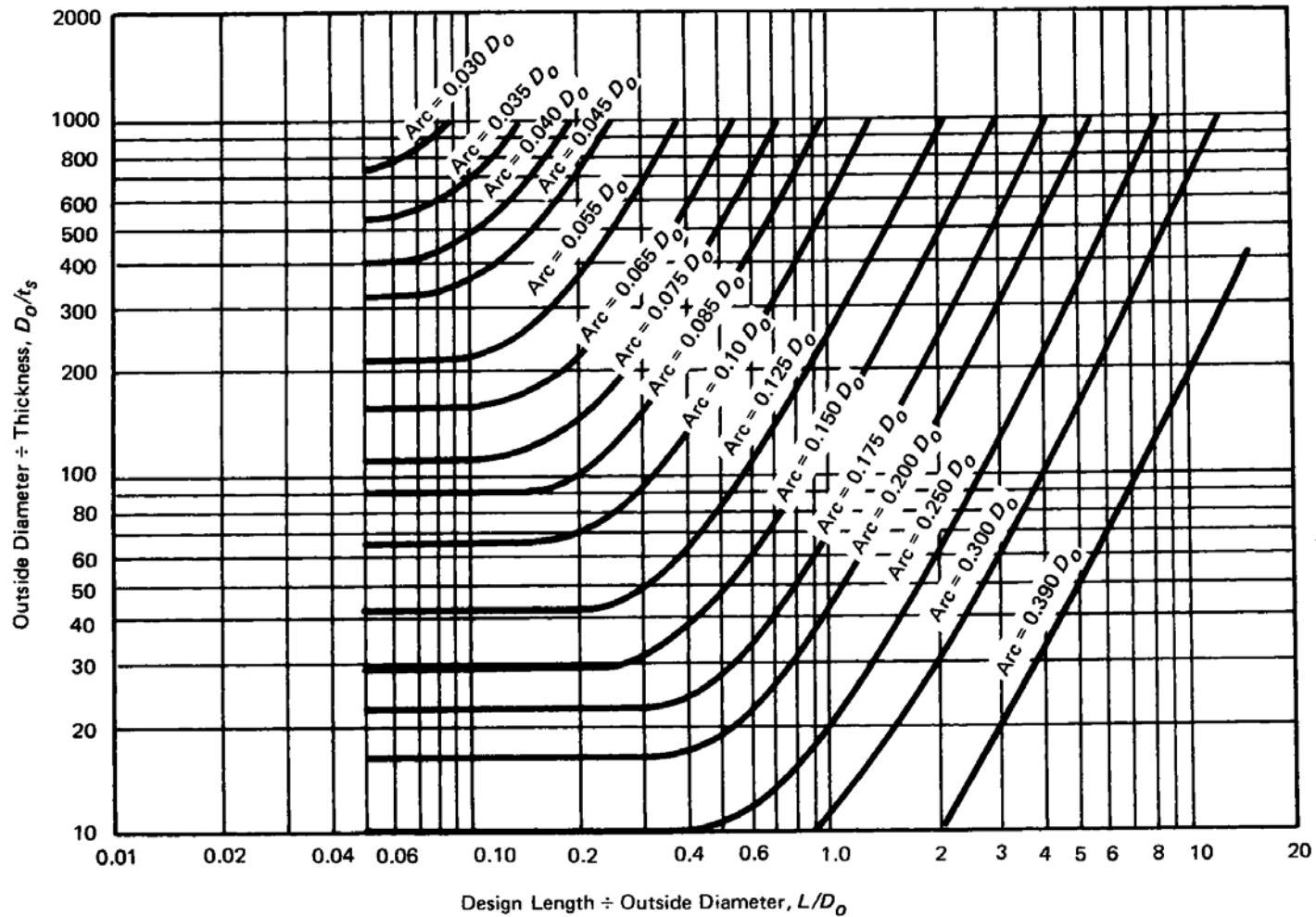
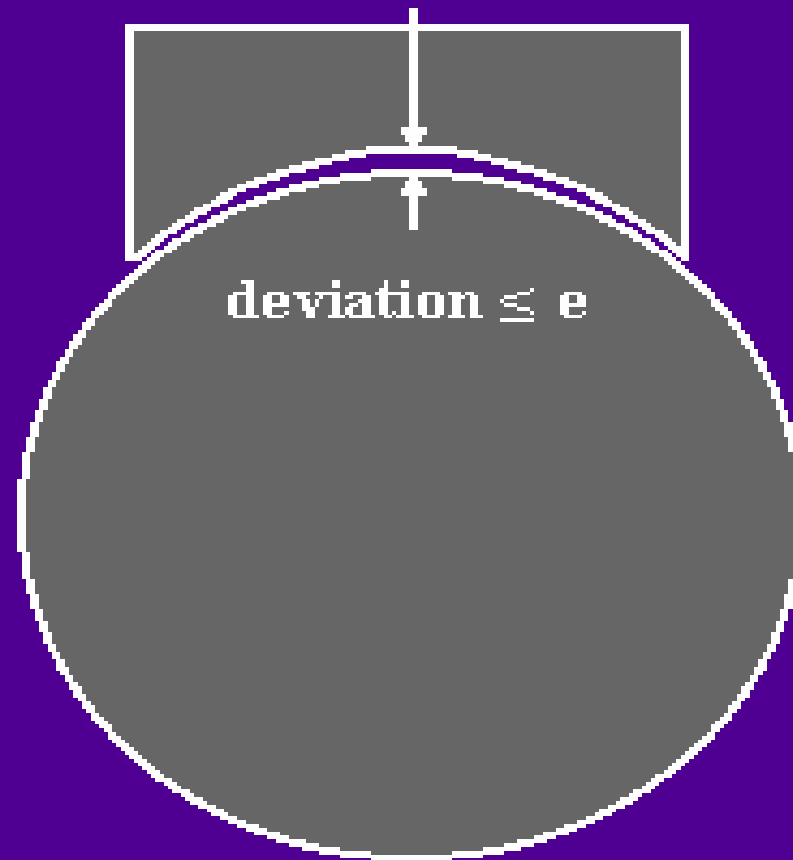

FIG. UG-29.2 MAXIMUM ARC OF SHELL LEFT UNSUPPORTED BECAUSE OF GAP IN STIFFENING RING OF CYLINDRICAL SHELL UNDER EXTERNAL PRESSURE



Segmental Circular Template





Inspection and Tests - Manufacturer

- qualification of the welding and/or brazing procedures before they are used in fabrication [UG-84(h), UW-28(b), and UB-31];
- qualification of welders and welding operators and brazers before using the welders or brazers in production work (UW-29, UW-48, UB-32, and UB-43);

Welding Processes

- Arc Welding processes
 - SMAW, GTAW, SAW, GMAW
- Stud Welding
- Electroslag Welding
- Electrogas Welding



Permitted Welding Processes

UW-27 WELDING PROCESSES

(a) The welding processes that may be used in the construction of vessels under this Part of this Division are restricted as follows:

(1) arc welding processes: atomic hydrogen, electro-gas, gas metal arc, gas tungsten arc, plasma arc, shielded metal arc, stud, and submerged arc;

(2) other than arc welding processes: electron beam, flash, electroslag, explosive,⁶ induction, inertia and continuous drive friction, laser beam, oxyfuel gas, resistance, and thermit.

(b) Other than pressure inherent to the welding processes, no mechanical pressure or blows shall be applied except as permitted for peening in UW-39.



UW-28 Welding Procedures

- Welding of pressure parts and of joining load-carrying, nonpressure-bearing parts to pressure parts shall be qualified in accordance with ASME Section IX
- Welding of nonpressure-bearing attachments with no load-carrying function to pressure parts welded manually, semi-automatically or machine-welded shall be qualified in accordance with ASME Section IX.



UW-28: Welding Procedures

- Welding of nonpressure bearing attachments, with no load-carrying function to pressure parts, welded using automatic welding requires a procedure but qualification is *not required*



Welder Qualification

- Welders must be qualified when welding pressure parts or load-carrying, nonpressure-bearing parts
- Welders may be qualified using production welds



Inspection and Tests - Manufacturer

- examination of all parts prior to joining to make certain they have been properly fitted for welding or brazing and that the surfaces to be joined have been cleaned and the alignment tolerances are maintained (UW-31, UW-32, UW-33, and UB-17);



Alignment Requirements

Butt Joint

- Definition: Per ASME Code IX, a joint aligned on the same plane, not exceeding 30 degrees

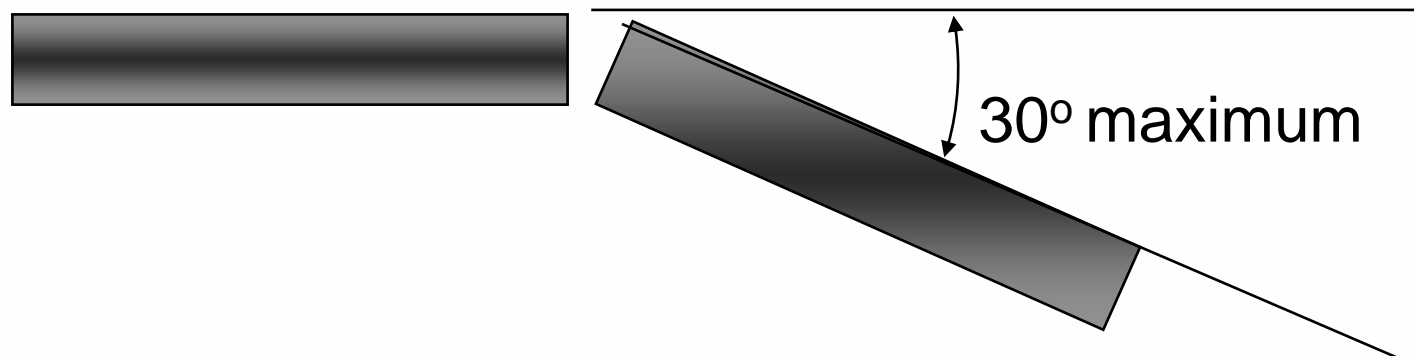



Alignment Tolerance

TABLE UW-33

SI Units		
Section Thickness, mm	Joint Categories	
	A	B, C, & D
Up to 13, incl.	$\frac{1}{4}t$	$\frac{1}{4}t$
Over 13 to 19, incl.	3 mm	$\frac{1}{4}t$
Over 19 to 38, incl.	3 mm	5 mm
Over 38 to 51, incl.	3 mm	$\frac{1}{8}t$
Over 51	Lesser of $\frac{1}{16}t$ or 10 mm	Lesser of $\frac{1}{8}t$ or 19 mm

Unequal Thickness

- Butt joints of unequal thickness shall have a tapered transition of not less than 3:1 when the difference in thickness varies more than $1/4t$ (thinner plate) or $1/8''$, whichever is less
- Taper may be machined or welded
- Weld metal build up shall be subject to the requirements of UW-42

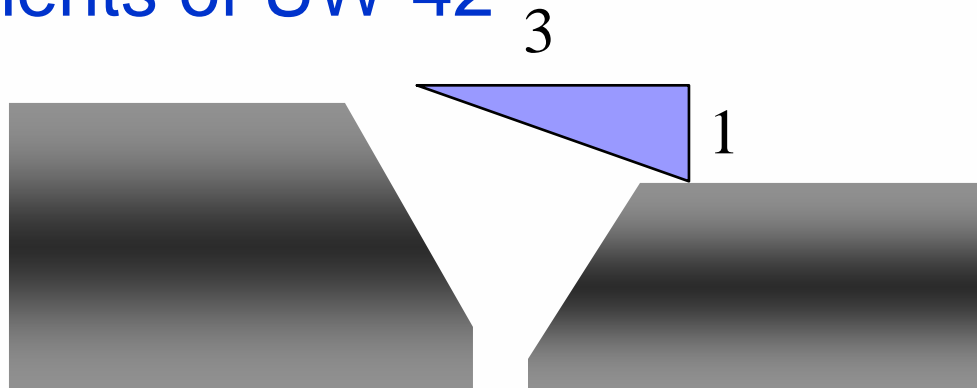



UW-42 SURFACE WELD METAL BUILDUP

(1) A butt welding procedure qualification in accordance with provisions of Section IX must be performed for the thickness of weld metal deposited, prior to production welding.

(2) All weld metal buildup must be examined over the full surface of the deposit by either magnetic particle examination to the requirements of Appendix 6, or by liquid penetrant examination to the requirements of Appendix 8.

When such surface weld metal buildup is used in welded joints which require full or spot radiographic examination, the weld metal buildup shall be included in the examination.



Inspection of Finished Welds



Root Area

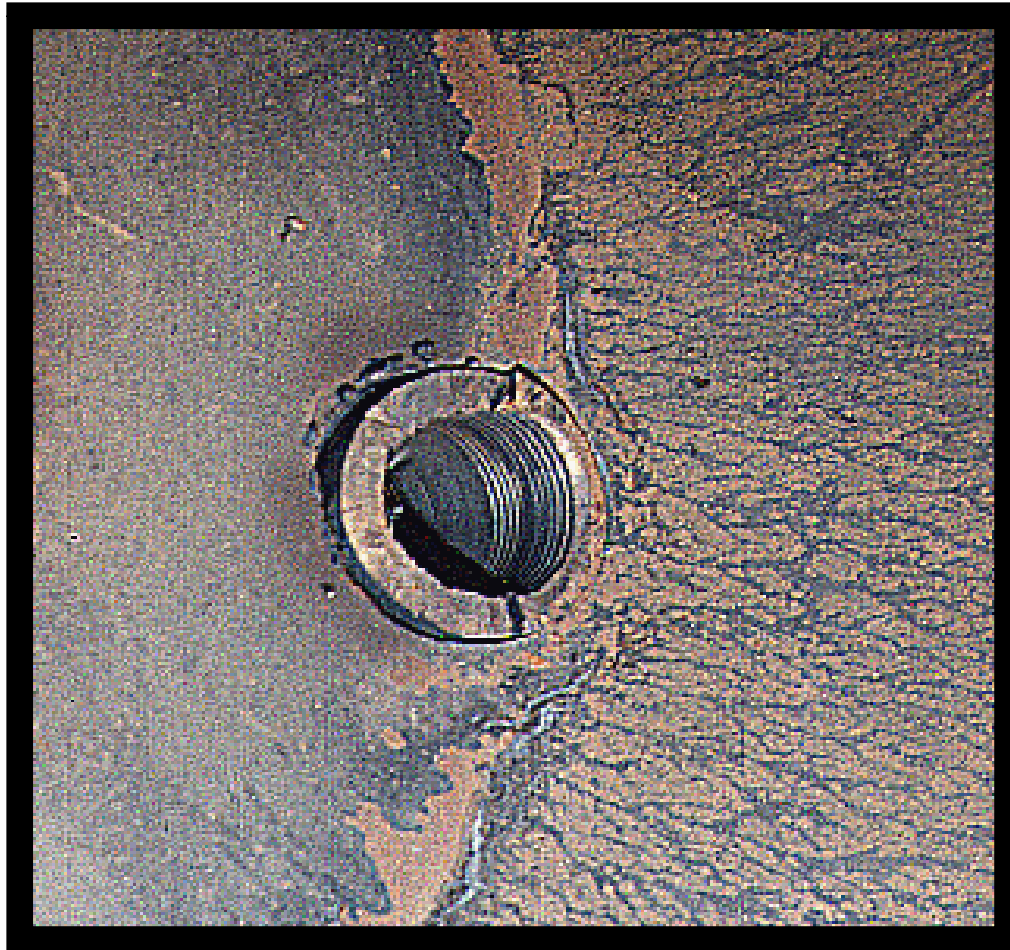

Lack of Penetration Nozzle Weld

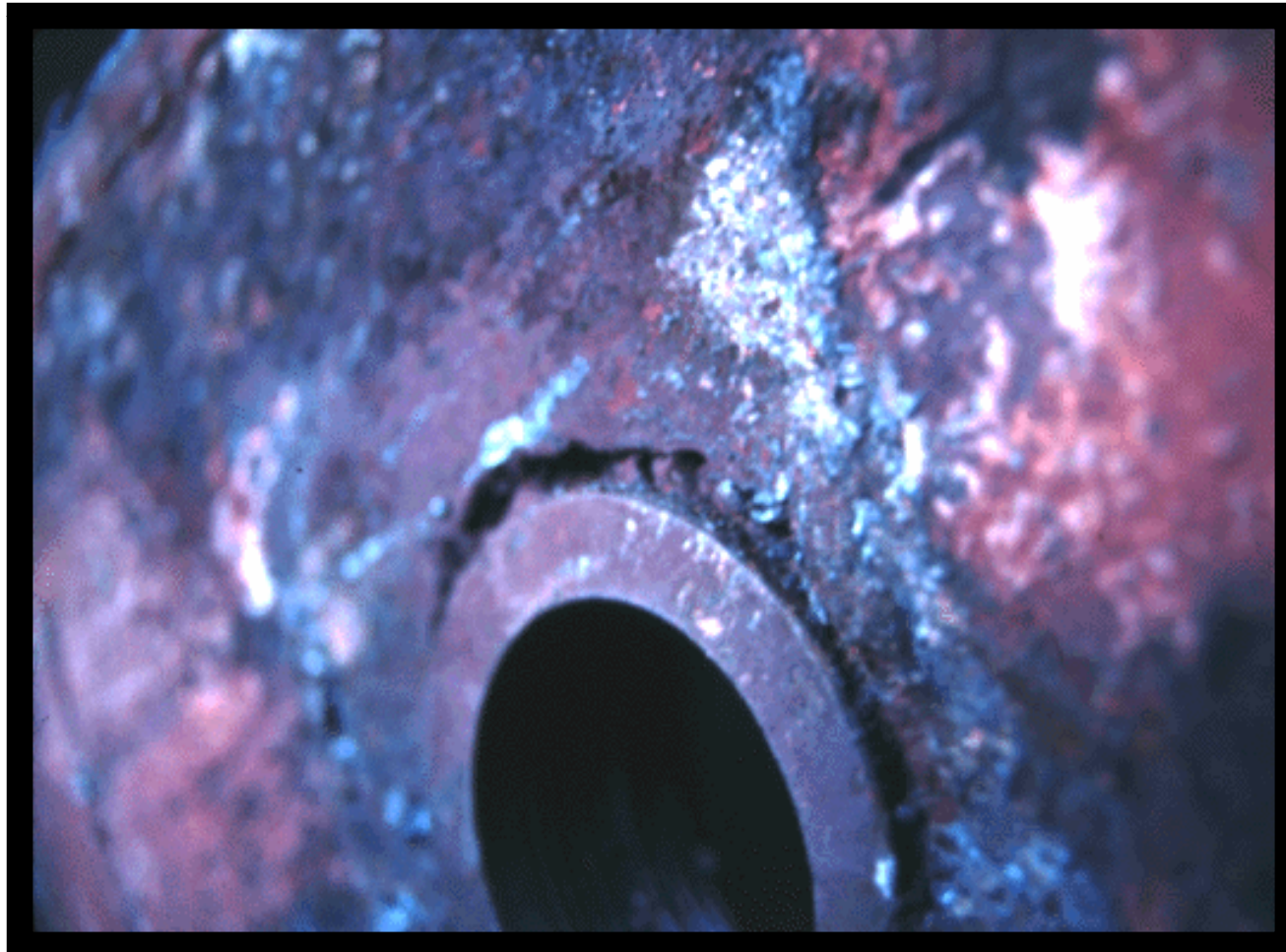



Attachments

- Non-pressure retaining parts welded over pressure retaining welds must be notched or the weld ground flush
- Pressure retaining parts welded over pressure retaining welds must be ground flush



UG-82 LUGS AND FITTING ATTACHMENTS

All lugs, brackets, saddle type nozzles, manhole frames, reinforcement around openings, and other appurtenances shall be formed and fitted to conform reasonably to the curvature of the shell or surface to which they are attached.

- (a) When pressure parts, such as saddle type nozzles, manhole frames, and **reinforcement around openings**, extend over pressure retaining welds, such welds shall be ground flush for the portion of the weld to be covered.*
- (b) When nonpressure parts, such as lugs, brackets, and support legs and saddles, extend over pressure retaining welds, such welds shall be ground flush as described in (a) above, or such parts shall be notched or coped to clear those welds.*



Notched Support

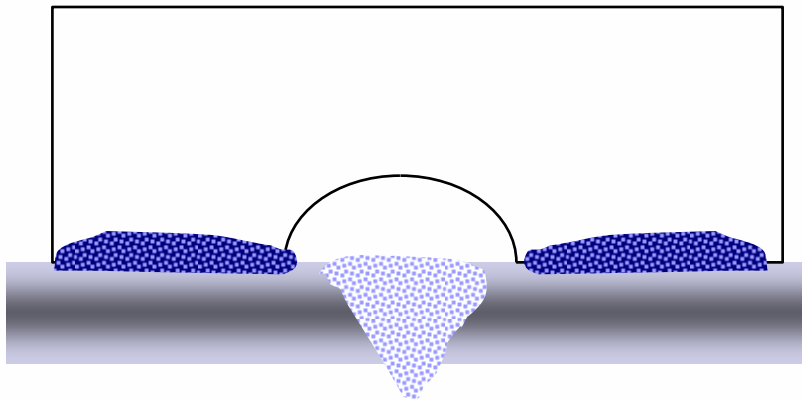

Option "A"

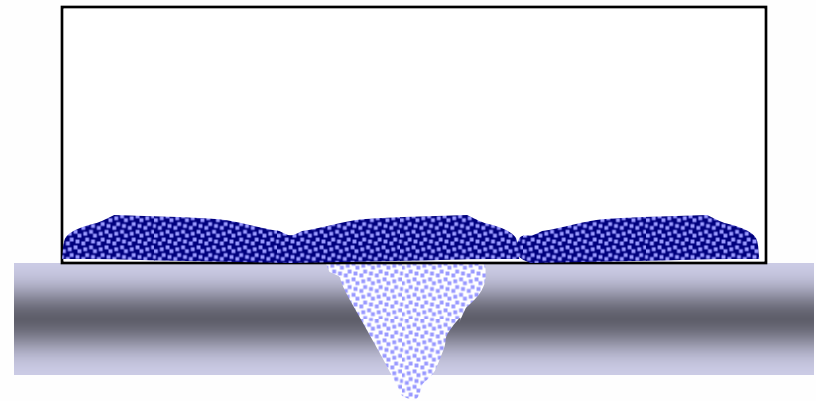

Option "B"



UW-9(d): Long Seams

Vessels made up of two or more shell courses

- Long seams between courses shall be staggered at a distance at least 5 times the thickness of the thicker plate

or

- 4" of the joints on each side of the girth seam shall be radiographed

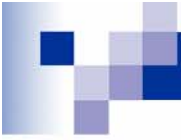



UW-35: Undercut

■ Longitudinal and Girth Welds

- Undercut is allowable if within 1/32" or 10% on the nominal plate thickness, whichever is less
- Reduction in thickness is not less than the minimum required thickness

Note: It is not the intent of this Code paragraph to require measurement of reductions in thickness due to the welding process. If a disagreement between the Manufacturer and the Inspector exists as to the acceptability of any reduction in thickness, the depth shall be verified by actual measurement.

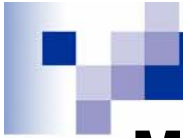

Measurement for Undercut





Finished Weld Reinforcement

UW-35 FINISHED LONGITUDINAL AND CIRCUMFERENTIAL JOINTS

SI Units

Material Nominal Thickness, mm	Maximum Reinforcement, mm.	
	Category B & C Butt Welds	Other Welds
Less than 2.4	2.4	0.8
2.4 to 4.8, incl.	3.2	1.6
Over 4.8 to 13, incl.	4.0	2.4
Over 13 to 25, incl.	4.8	2.4
Over 25 to 51, incl.	5	3.2
Over 51 to 76, incl.	6	4
Over 76 to 102, incl.	6	6
Over 102 to 127, incl.	6	6
Over 127	8	8



Welder Traceability

UW-37 MISCELLANEOUS WELDING REQUIREMENTS

(f) Welder and Welding Operator Identification

(1) Each welder and welding operator shall stamp the identifying number, letter, or symbol assigned by the Manufacturer, on or adjacent to and at intervals of not more than 3 ft (1 m) along the welds which he makes in steel plates $\frac{1}{4}$ in. (6 mm) and over in thickness and in nonferrous plates $\frac{1}{2}$ in. (13 mm) and over in thickness; or a record shall be kept by the Manufacturer of welders and welding operators employed on each joint which shall be available to the Inspector. For identifying welds on vessels



Openings At or Near a Weld

- UW-14 allows openings at weld seam provided:
 - Reinforcement calculation meets UG-37/ UG-39
 - Openings meeting UG-36(c)(3) may be located at category B or C joints provided a length of 3 time the diameter on both sides are radiographed
 - Openings should be located at least 1/2" from seams on plate thickness up to 1-1/2"

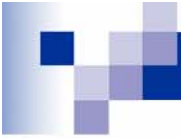

UW-14(d) Except when the adjacent butt weld satisfies the requirement for radiography in (b) above, the edge of openings in solid plate meeting the requirements of UG-36(c)(3) shall not be placed closer than $\frac{1}{2}$ in. (13 mm) from the edge of a Category A, B, or C weld for material $1\frac{1}{2}$ in. (38 mm) thick or less.



UW-14

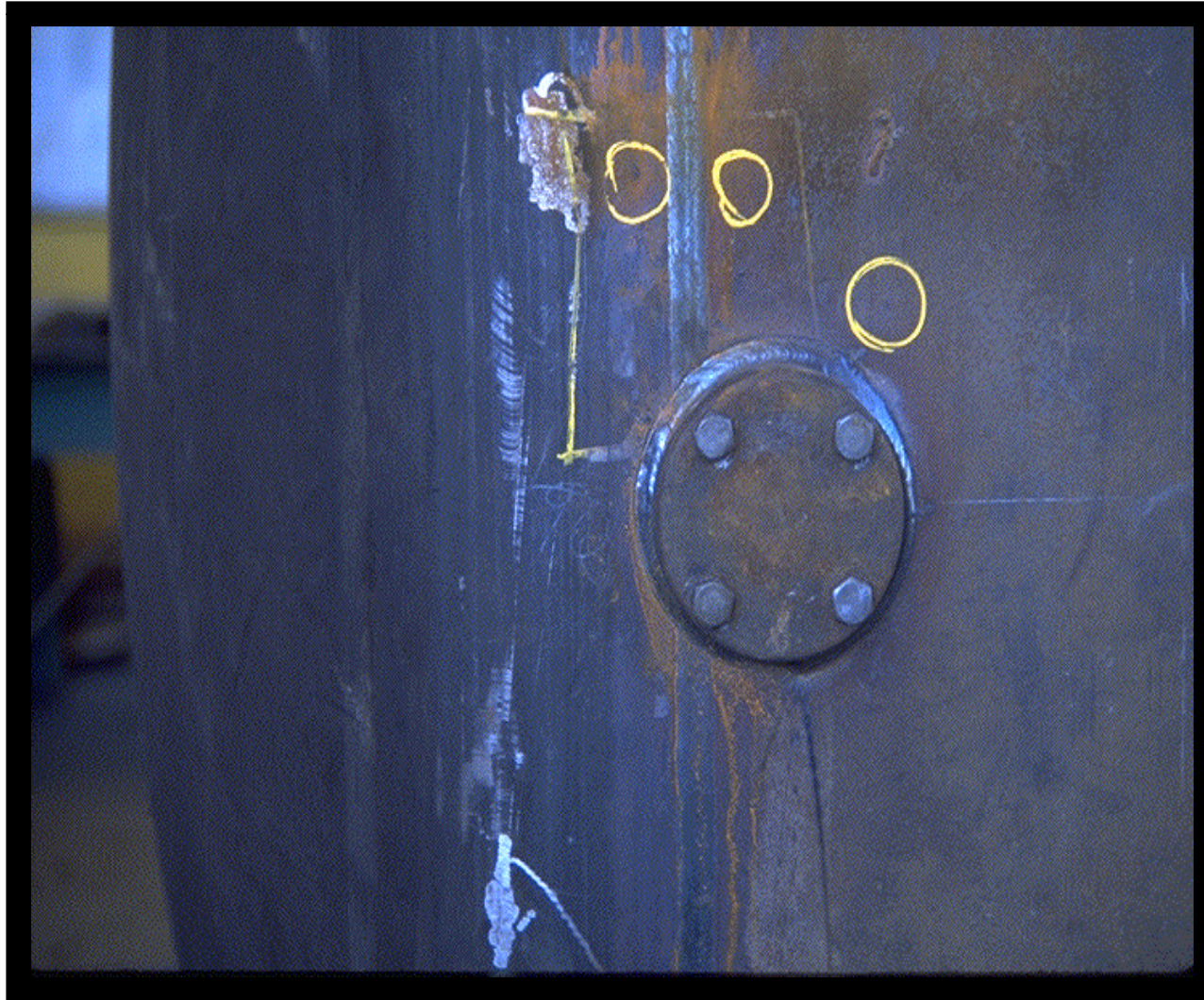



Inspection of Welds

- WPS, WPQ
- Materials are acceptable to Code
- Fit-up geometry meets the requirements of the WPS and tacks welds are acceptable
- Root pass is inspected
- Inspect back gauge to sound metal
- Inspection of finished weld on both sides
- Welder traceability
- Perform required NDE



Inspection and Tests - Manufacturer

- examination of parts as fabrication progresses, for material marking (UG-94), that defects are not evident (UG-95), and that dimensional geometries are maintained (UG-96 and UF-30);
 - shape verification by use of template
 - Vessel attachments like nozzles to be checked to ensure that they properly fit vessel curvature
- verification to assure that all required heat treatments are performed (UW-2, UW-10, UG-85, UF-31, and 10-11);



When required UCS-56

“Except as otherwise specifically provided in the notes to Table UCS-56, all welds in pressure vessels or pressure vessel parts shall be given a PWHT at a temperature not less than specified in those tables when the nominal thickness including corrosion allowance exceeds the limits of those tables.”

- UCS - 56 Thickness considerations
- UW-2 Service considerations



Exemptions

Thickness exemptions for different P-Numbers:

- P-No.1 Group 1,2,3 = up to 1-1/4"
- P-No.3 Group 1,2 = up to 5/8"
- P-No.4 Group 1,2 = No exemption for plates
- P No.5 A,B,C = No exemption for plates

- 
- PWHT need not be in one continuous cycle. It may be performed in multiple cycles
 - Welding of parts with different P nos., use table with the higher PWHT temperature
 - Welding pressure parts to non pressure parts: PWHT temp for pressure parts shall govern



Interpretation: VIII-1-89-30

Subject: Section VIII, Division 1 (1986 Edition, 1987 Addenda)
Table UCS-56

Date Issued: September 20, 1988

File: BC88-192

Question: A P-No. 1 Group No. 2 plate has a specified nominal thickness of 1-1/2 in. It has a measured maximum thickness which exceeds this value, but is in accordance with the tolerances permitted in Table A1.1 of SA-20 in Section II, Part A. Is this plate exempt from post weld heat treatment by Note (2)(a) of Table UCS-56, provided the preheat is performed as required by this Note?

Reply: Yes.



Inspection and Tests - Manufacturer

- making the required hydrostatic or pneumatic test and having the required inspection performed during such test (UG-99, UG-100, and UW-50);
- applying the required stamping and/or nameplate to the vessel and making certain it is applied to proper vessel (UG-116, UG-118, and UG-119);
- preparing required Manufacturer's Data Report and having it certified by the Inspector (UG-120);
- retention of radiographs (UW-51), ultrasonic test reports (12-4), Manufacturer's Data Reports (UG-120), and other documents as required by this Division (10-13).



Hydrostatic Test

UG-99 STANDARD HYDROSTATIC TEST

(b) Except as otherwise permitted in (a) above and 27-4, vessels designed for internal pressure shall be subjected to a hydrostatic test pressure which at every point in the vessel is at least equal to 1.3 times the maximum allowable working pressure to be marked on the vessel multiplied by the lowest ratio (for the materials of which the vessel is constructed) of the stress value S for the test temperature on the vessel to the stress value S for the design temperature (see UG-21).



Hydrostatic Test

UG-99 STANDARD HYDROSTATIC TEST

(f) Single-wall vessels designed for a vacuum or partial vacuum only, and chambers of multichamber vessels designed for a vacuum or partial vacuum only, shall be subjected to an internal hydrostatic test or when a hydrostatic test is not practicable, to a pneumatic test in accordance with the provisions of UG-100. Either type of test shall be made at a pressure not less than 1.3 times the difference between normal atmospheric pressure and the minimum design internal absolute pressure.

Marking

	Certified by

	(Name of Manufacturer)
	(Pressure) ____ at (temperature) ____ Max. allowable working pressure
	(Pressure) ____ at (temperature) ____ Max. allowable external working pressure [if specified; see Note (1)]
W (if arc or gas welded) RT (if radiographed) HT (if postweld heat treated)	(Temperature) ____ at (pressure) ____ Min. design metal temperature

	Manufacturer's serial number

	Year built

GENERAL NOTE: Information within parentheses is not part of the required marking. Phrases identifying data may be abbreviated; minimum abbreviations shall be MAWP, MAEWP, MDMT, S/N, and year, respectively.

NOTE:

(1) The maximum allowable external working pressure is required only when specified as a design condition.



Inspection and Tests – Authorized Inspector

All inspections specifically required of him plus such other inspections as he believes are necessary to enable him to certify that all vessels which he authorizes to be stamped with the Code Symbol have been designed and constructed in accordance with the requirements of this Division.

- verifying that the Manufacturer has a valid Certificate of Authorization [UG-117(a)] and is working to a Quality Control System [UG-117(e)];
- verifying that the applicable design calculations are available [U-2(b), U-2(c), 10-5, and 10-15(d)];
- verifying that materials used in the construction of the vessel comply with the requirements of UG-4 through UG-14 (UG-93);
- verifying that all welding and brazing procedures have been qualified (UW-28, UW-47, and UB-42);
- verifying that all welders, welding operators, brazers, and brazing operators have been qualified (UW-29, UW-48, and UB-43);



Inspection and Tests – Authorized Inspector

- verifying that the heat treatments, including PWHT, have been performed (UG-85, UW-10, UW-40, UW-49, and UF-52);
- verifying that material imperfections repaired by welding were acceptably repaired [UG-78, UW-52(d)(2)(c), UF-37, and UF-47(c)];
- verifying that weld defects were acceptably repaired [UW-51(c) and UW-52(c)];
- verifying that required nondestructive examinations, impact tests, and other tests have been performed and that the results are acceptable (UG-84, UG-93, UW-50, UW-51, UW-52, and UB-44);
- making a visual inspection of vessel to confirm that the material identification numbers have been properly transferred (UG-77 and UG-94);
- making a visual inspection of the vessel to confirm that there are no material or dimensional defects (UG-95, UG-96, and UG-97);



Inspection and Tests – Authorized Inspector

- Performing internal and external inspections and witnessing the hydrostatic or pneumatic tests (UG-96, UG-97, UG-99, UG-100, and UG-101);
- verifying that the required marking is provided (UG-115) and that any nameplate has been attached to the proper vessel;
- signing the Certificate of Inspection on the Manufacturer's Data Report when the vessel, to the best of his knowledge and belief, is in compliance with all the provisions of this Division.



Inspection and Tests – Authorized Inspector

Multiple, duplicate pressure vessels

Manufacturer, in collaboration with the Inspector prepares an inspection and quality control procedure setting forth, in complete detail, the method by which the requirements of this Division will be maintained.

This procedure is included in the Manufacturer's written Quality Control System [see UG-117(e)].

This procedure, after acceptance of the inspection agency, is submitted by the inspection agency for written acceptance by the legal jurisdiction concerned [see UG-117(f)] and by an ASME Designee.

The joint reviews include an ASME Designee.

Any changes in this inspection and quality control procedure which affect the requirements of this Division are subject to review and acceptance by the parties required for a joint review. The Data Report for such a vessel shall include under "Remarks" the statement:

"Constructed under the provisions of UG-90(c)(2)."

Broad Spectrum of Services

Analytical Services

- * Structural Analysis.
- * Stability Analysis
- * Risers Analysis
- * Reliability Engineering
- * Corrosion & Materials Selection
- * Fire and Explosion Analysis
- * Root Cause Analysis
- * Human Factors
- * Life-Cycle Costing

Operational Support Services

- * AIM Strategy/Integrity Management Program
- * In-Service Inspection / Inspection Program
- * RBI Program
- * RCM (Risk/Reliability) Program
- * Materials & Corrosion Engineering
- * Baseline Condition Assessment
- * Chemicals/Spares Management
- * Performance Metrics/KPI's
- * Integrated Inspection Database
- * Rapid Response Damage Assessment/ Emergency Response.
- * Expert Witness
- * Maintenance Manuals
- * Structural Repair Design
- * Critical Spares Analysis

Risk Management Services

- * HAZID/HAZOP/ FMEA/PHSER
- * Bow-Tie Analysis
- * Hazard/ Consequence Analysis
- Risk Assessment/QRA
- PSA / PSM
- * Reliability Analysis
- * Emergency Response Planning
- * HSEIA /COMAH/Safety Case
- * SIL/LOPA
- * Incident Investigation
- * Cost Benefit Analysis
- * Event Tree/Fault Tree Analysis

Construction Services

- * Design Engineering Review
- * Document Management Vendor /Materials Inspection
- Coating Inspection
- Third Party Inspection
- PED Notified Body Services
- * Welding Inspection
- * Fabrication/ Installation Inspection
- * **ASME Inspection Services – Nuclear & Non Nuclear**
- * Construction Plan Compliance
- * Lifting Equipment Load Test
- * Lifting Equipment Condition Inspection

HSE Critical Services

- * Independent Competent Person /Independent Verification Body (ICP/IVB)
- * 3rd Party Inspection
- * ASME Authorized Verification Agent
- * SCE/HSECES Identification
- * Performance Standards
- * Verification / Examination Scheme