

TUTORIAL

CENTRIFUGAL PUMP SYSTEMS

by Jacques Charette p. eng.

© copyright 2005

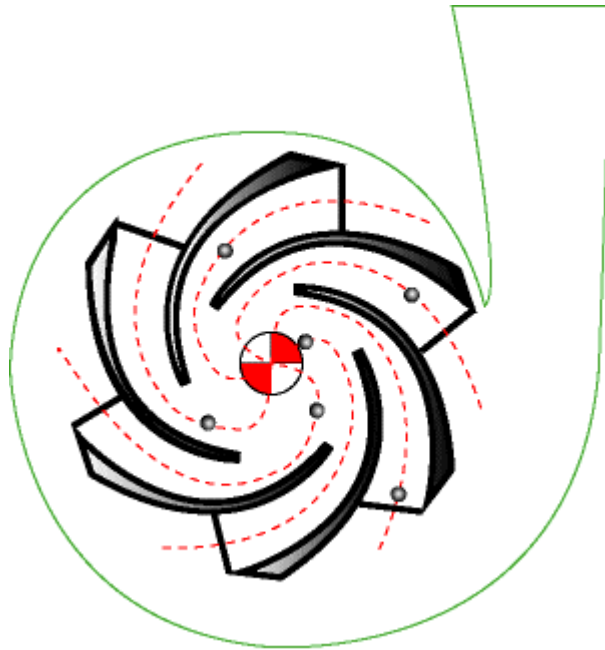

Table of contents

1. Different types of pump systems
2. Three important characteristics of a pump system: pressure, friction and flow
3. What is friction in a pump system
4. Energy and head in pump systems
5. Static head
6. Flow rate depends on elevation difference or static head
7. Flow rate depends on friction
8. How does a centrifugal pump produce pressure
9. What is total head
10. What is the relationship between head and total head
11. How to determine friction head
12. The performance or characteristic curve of the pump
13. How to select a centrifugal pump
Examples of total head calculations - sizing a pump for a home owner application
14. Examples of common residential water systems
15. Calculate the pump discharge pressure from the pump total head

Appendix A

Flow rate and friction loss for different pipe sizes based at different velocities

Appendix B

Formulas and an example of how to do pipe friction calculations

Appendix C

Formulas and an example of how to do pipe fittings friction calculations

Appendix D

Formula and an example of how to do velocity calculation for fluid flow in a pipe

Appendix E

The relationship between pressure head and pressure

Foreword

This tutorial is intended for anyone that has an interest in centrifugal pumps. There is no math, just simple explanations of how pump systems work and how to select a centrifugal pump. For those who want to do detail calculations, some examples have been included in the appendices.

This tutorial answers the following questions:

- What are the important characteristics of a pump system?
- What is head and how is it used in a pump system to make calculations easier?
- What is static head and friction head and how do they affect the flow rate in a pump system?
- How does a centrifugal pump produce pressure?
- Why is total head and flow the two most important characteristics of a centrifugal pump?
- What is meant by the pump rating? And what is the optimal operating point of a centrifugal pump?
- How to do details calculations that will allow you to size and select a centrifugal pump?
- How to verify that your centrifugal pump is providing the rated pressure or head?
- What is density and specific gravity and how do they relate to pressure and head?

1. Different types of pump systems

There are many types of centrifugal pump systems. Figure 1 shows a typical industrial pump system. There are many variations on this including all kinds of equipment that can be hooked up to these systems that are not shown. A pump after all is only a single component of a process although an important and vital one. The pumps' role is to provide sufficient pressure to move the fluid through the system at the desired flow rate.

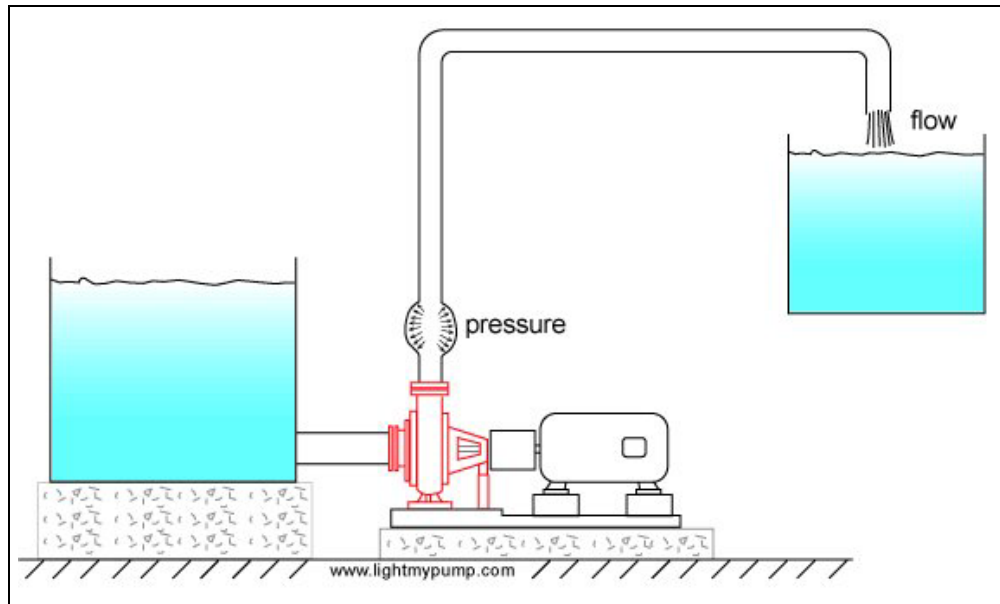

Figure 1 Typical industrial pump system.

Back in the old days domestic water supply was simpler...aaah the good old days.
Goodnight John boy..

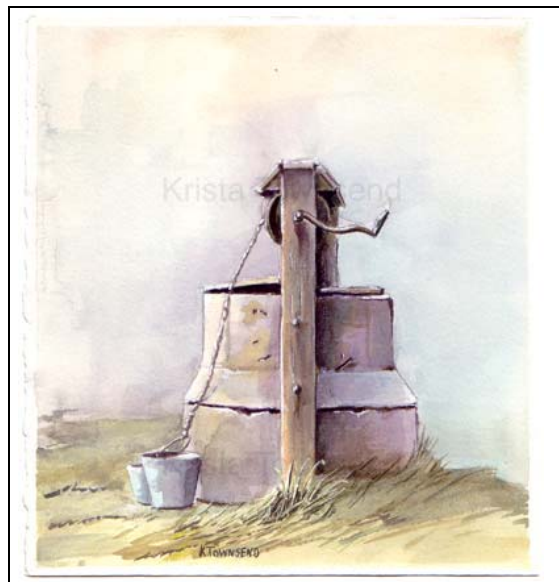

Figure 1a The old days.

Domestic water systems take their water from various sources at different levels depending on the water table and terrain contours.

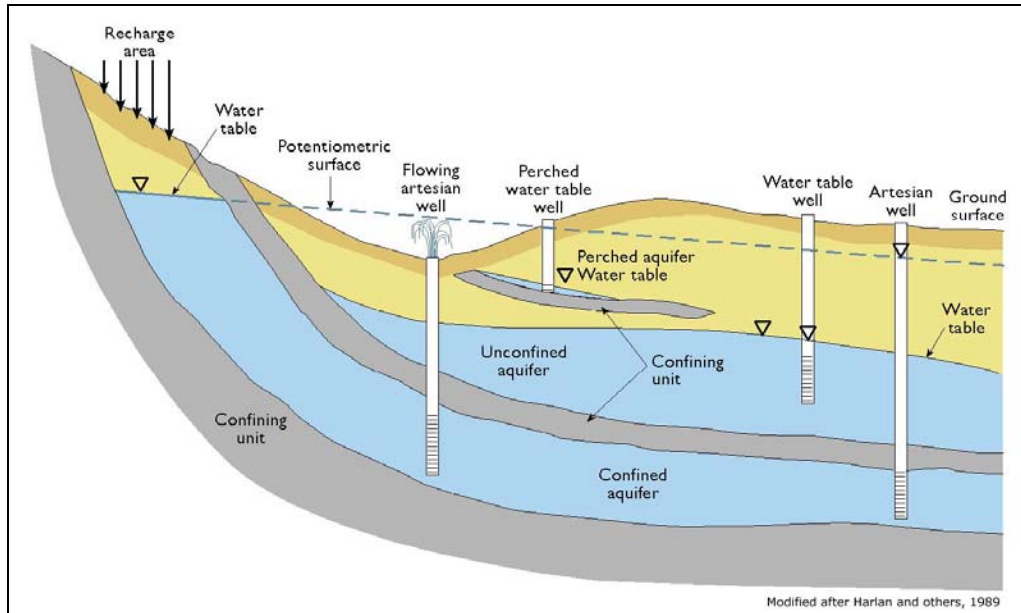

Figure 1b Water supply sources (source: *The Ground Water Atlas of Colorado*).

The system in Figure 2 is a typical domestic water supply system that takes its water from a shallow well (25 feet down max.) using an end suction centrifugal pump. A jet pump works well in this application (see <http://www.watertanks.com/category/43/>).

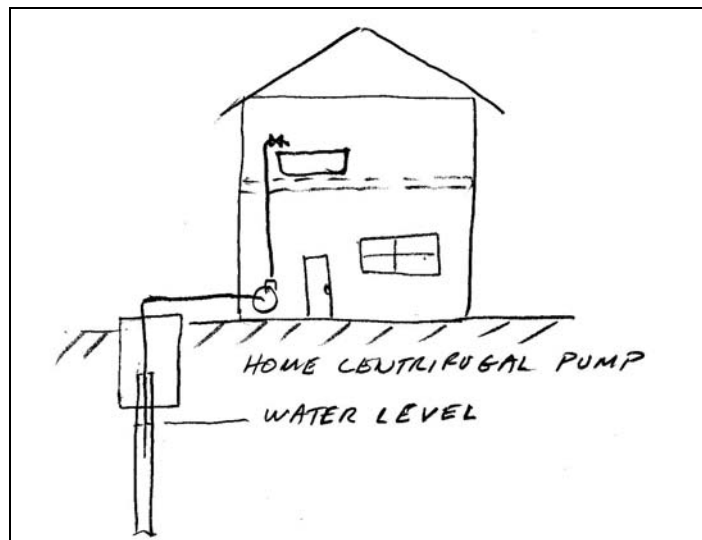

Figure 2 Typical residential pump system.

The system in Figure 3 is another typical domestic water supply system that takes its water from a deep well (200-300 feet) and uses a multi-stage submersible pump often called a turbine pump (http://www.webtrol.com/domestic_pumps/8in_turbine.htm).



Figure 2a Typical jet pump.

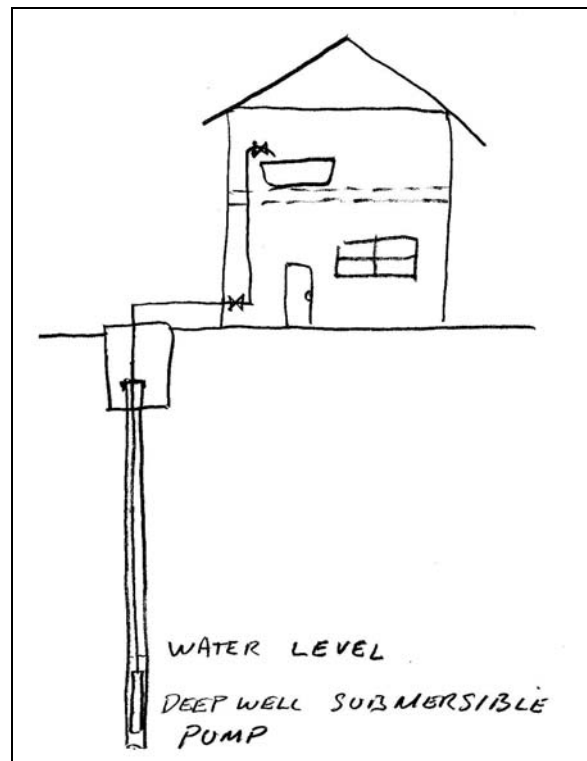

Figure 3 Typical residential deep well pump system.

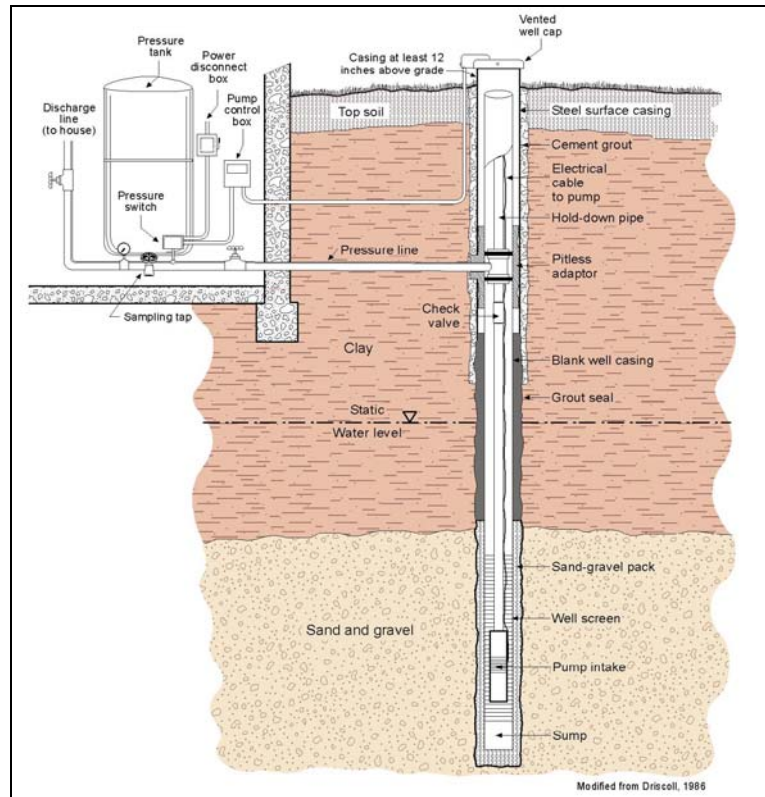

Figure 3a Typical residential deep well pump system (source: The Ground Water Atlas of Colorado).

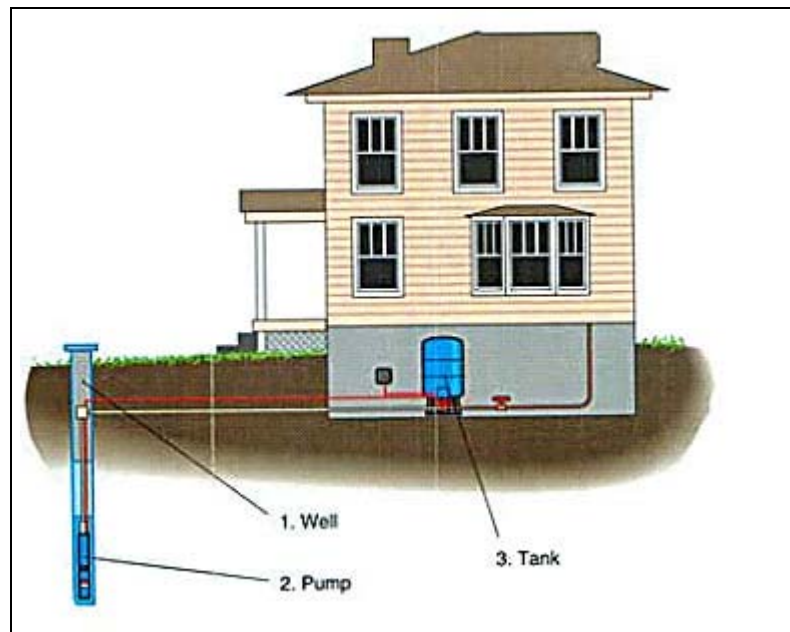

Figure 3b Another representation of a typical residential deep well pump system.



Figure 3c Typical deep well residential submersible pump.

2. Three important characteristics of pump systems: pressure, friction and flow

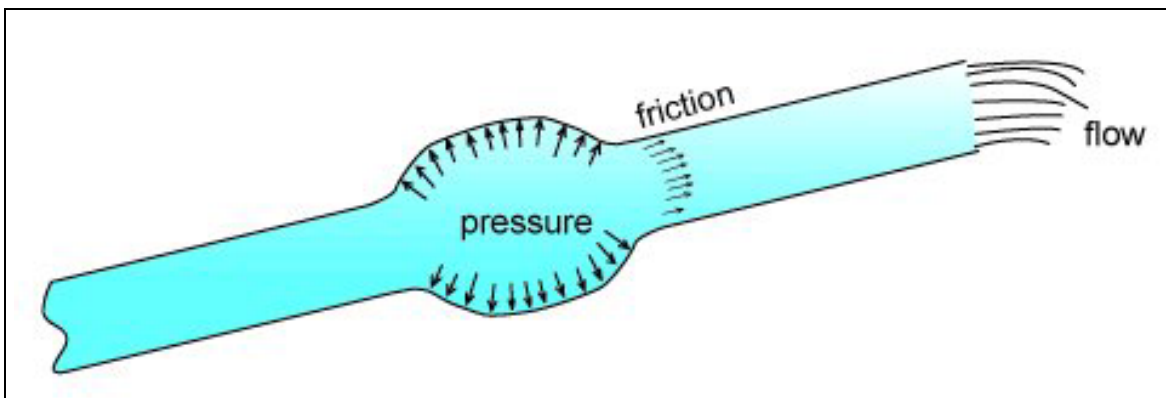

Figure 4 Three important characteristics of pump systems.

Pressure, friction and flow are three important characteristics of a pump system. Pressure is the driving force responsible for the movement of the fluid. Friction is the force that slows down fluid particles. Flow rate is the amount of volume that is displaced per unit time. The unit of flow in North America, at least in the pump industry, is the US gallon per minute, USgpm. From now on I will just use gallons per minute or gpm. In the metric system, flow is in liters per second (L/s) or meters cube per hour (m^3/h).

Pressure is often expressed in pounds per square inch (psi) in the Imperial system and kiloPascals (kPa) in the metric system. In the Imperial system of measurement, the unit psig or pounds per square inch gauge is used, it means that the pressure measurement is relative to the local atmospheric pressure, so that 5 psig is 5 psi above the local atmospheric pressure. The kPa unit scale is intended to be a scale of absolute pressure measurement and there is no kPag, but many people use the kPa as a relative measurement to the local atmosphere and don't bother to specify this. This is not a fault of the metric system but the way people use it. The term pressure loss or pressure drop is often used, this refers to the decrease in pressure in the system due to friction. In a pipe or tube that is at the same level, your garden hose for example, the pressure is high at the tap and zero at the hose outlet, this decrease in pressure is due to friction and is the pressure loss.

As an example of the use of pressure and flow units, the pressure available to domestic water systems varies greatly depending on your location with respect to the water treatment plant. It can vary between 30 and 70 psi or more. The following table gives the expected flow rate that you would obtain for different pipe sizes assuming the pipe or tube is kept at the same level as the connection to the main water pressure supply and has a 100 feet of length (see Figure 4a).

Flow rate based on available pressure and pipe size						
Nom. dia. (in)	Inside dia. (in)	Flow rate (gpm) @ 30 psi	Flow rate (gpm) @ 40 psi	Flow rate (gpm) @ 50 psi	Flow rate (gpm) @ 60 psi	Flow rate (gpm) @ 70 psi
1/4	0.311	1.3	1.5	1.7	1.9	2
1/2	0.527	5.4	6.3	7	7.7	8.5
3/4	0.745	13.6	15.6	17.7	20	21
1	0.995	29	34	38	42	46
1 1/2	1.6	103	119	135	147	160

Table 1 Expected flow rates for 100 feet of pipe of various diameters based on available pressure.

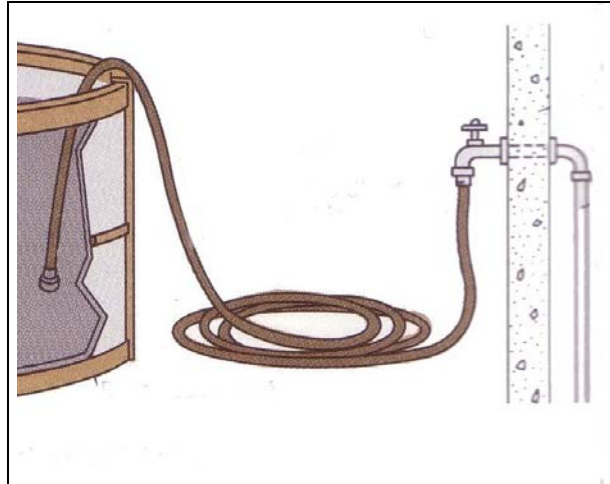

Figure 4a A typical garden hose connection, see Table 1 for flow rate vs. pressure.

The unit of friction is....Sorry, I think I need to wait 'til we get closer to the end to explain the reasoning behind this unit.

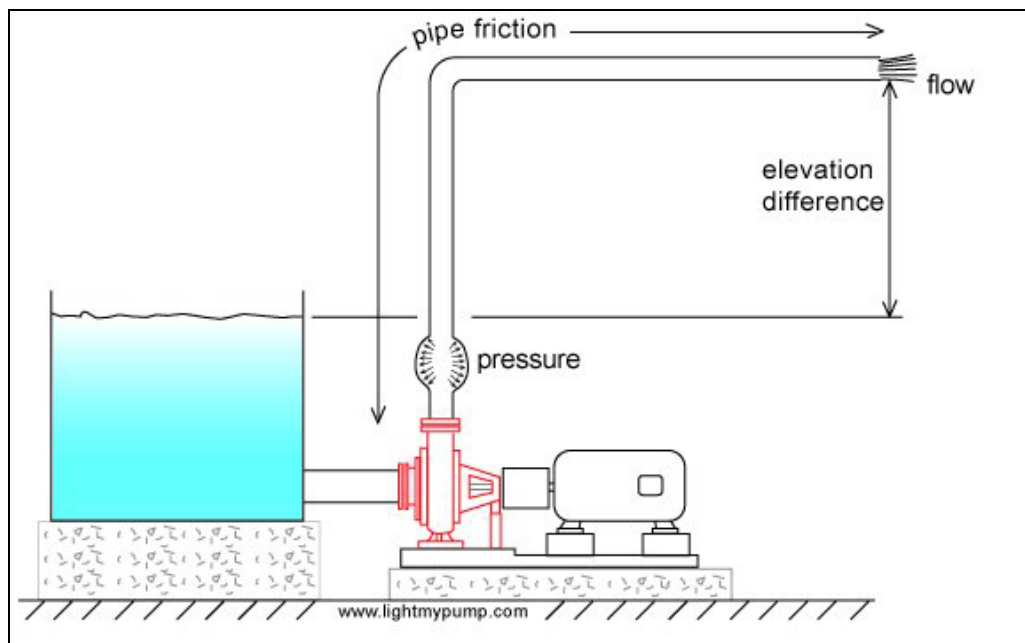

Figure 5 A typical pump system.

The pump provides the energy necessary to drive the fluid through the system and overcome friction and any elevation difference.

Pressure is increased when fluid particles are forced closer together. For example, in a fire extinguisher work or energy has been spent to pressurize the liquid chemical within, that energy can be stored and used later.

Is it possible to pressurize a liquid within a container that is open? Yes. A good example is a syringe, as you push down on the plunger the pressure increases, and the harder you have to push. There is enough friction as the fluid moves through the needle to produce a great deal of pressure in the body of the syringe.

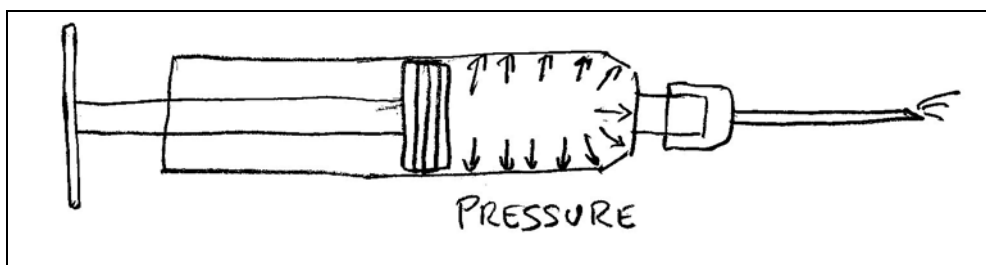

Figure 6 Pressure produced by fluid friction in a syringe.

If we apply this idea to the pump system of Figure 5, even though the discharge pipe end is open, it is possible to have pressure at the pump discharge because there is sufficient friction in the system and elevation difference.

3. What is friction in a pump system

Friction is always present, even in fluids, it is the force that resists the movement of objects.

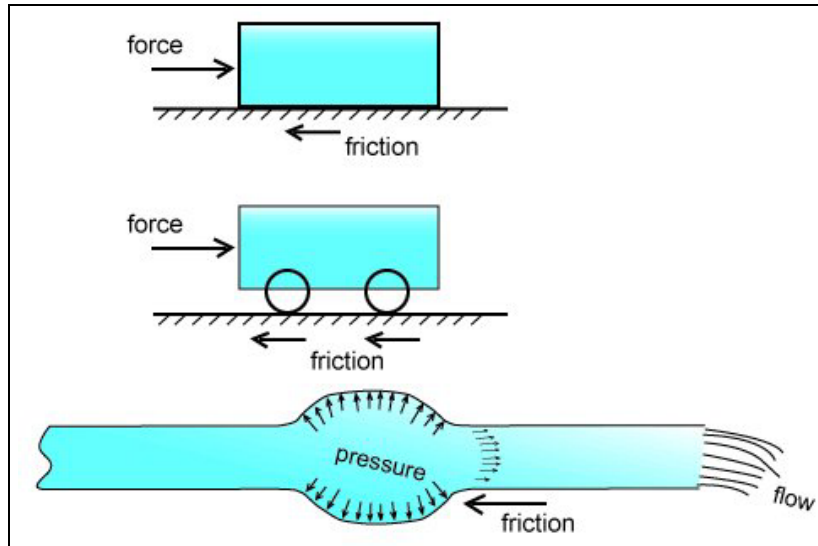

Figure 7 Friction, the force that resist movement.

When you move a solid on a hard surface, there is friction between the object and the surface. If you put wheels on it, there will be less friction. In the case of moving fluids such as water, there is even less friction but it can become significant for long pipes. Friction can be also be high for short pipes which have a high flow rate and small diameter as in the syringe example.

In fluids, friction occurs between fluid layers that are traveling at different velocities within the pipe (see Figure 8). There is a natural tendency for the fluid velocity to be higher in the center of the pipe than near the wall of the pipe. Friction will also be high for viscous fluids and fluids with suspended particles.

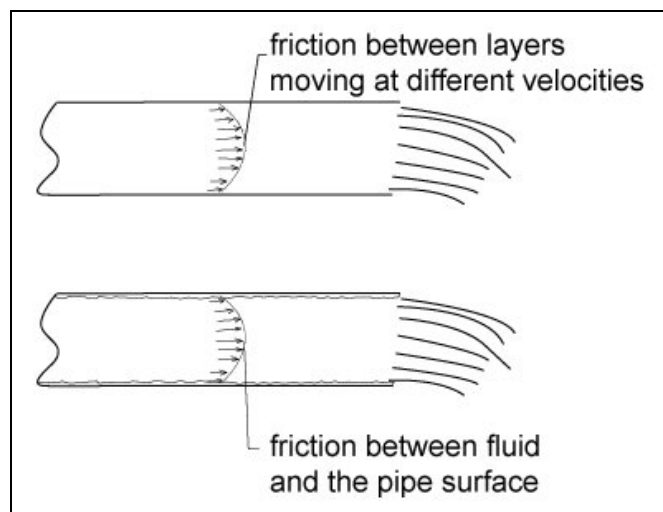

Figure 8 Friction between layers of fluid and the

pipe wall.

Another cause of friction is the interaction of the fluid with the pipe wall, the rougher the pipe, the higher the friction.

Friction depends on:

- average velocity of the fluid within the pipe
- viscosity
- pipe surface roughness

An increase in any one of these parameters will increase friction.

The amount of energy required to overcome the total friction loss within the system has to be supplied by the pump if you want to achieve the required flow rate. In industrial systems, friction is not normally a large part of a pump's energy output. For typical systems, it is around 25% of the total. If it becomes much higher then you should examine the system to see if the pipes are too small. However all pump systems are different, in some systems the friction energy may represent 100% of the pump's energy, This is what makes pump systems interesting, there is a million and one applications for them. In household systems, friction can be a greater proportion of the pump energy output, maybe up to 50% of the total, this is because small pipes produce higher friction than larger pipes for the same average fluid velocity in the pipe (see the friction chart later in this tutorial).

Another cause of friction are the fittings (elbows, tees, y's, etc) required to get the fluid from point A to B. Each one has a particular effect on the fluid streamlines. For example in the case of the elbow (see Figure 9), the fluid streamlines that are closest to the tight inner radius of the elbow lift off from the pipe surface forming small vortices that consume energy. This energy loss is small for one elbow but if you have several elbows and other fittings it can become significant. Generally speaking they rarely represent more than 30% of the total friction due to the overall pipe length.

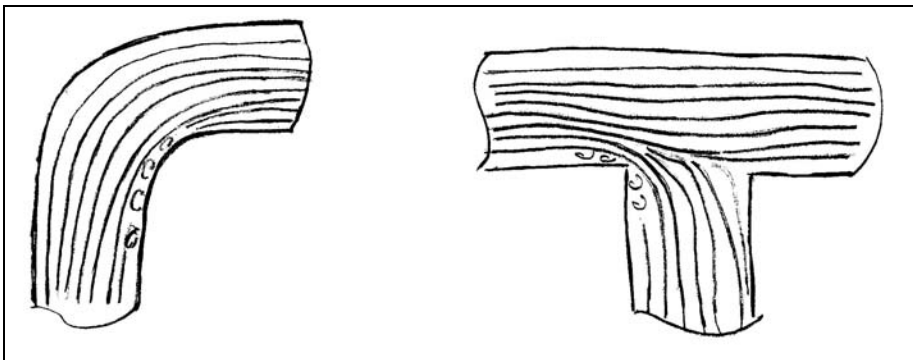

Figure 9 Streamline flow patterns for typical fittings such as an elbow and a tee.

4. Energy and head in pump systems

Energy and head are two terms that are often used in pump systems. We use energy to describe the movement of liquids in pump systems because it is easier than any other

method. There are four forms of energy in pump systems: pressure, elevation, friction and velocity.

Pressure is produced at the bottom of the reservoir because the liquid fills up the container completely and its weight produces a force that is distributed over a surface which is pressure. This type of pressure is called static pressure. Pressure energy is the energy that builds up when liquid or gas particles are moved slightly closer to each other. A good example is a fire extinguisher, work was done to get the liquid into the container and then to pressurize it. Once the container is closed the pressure energy is available for later use.

Any time you have liquid in a container, even one that is not pressurized, you will have pressure at the bottom due to the liquid's weight, this is known as static pressure.

Elevation energy is the energy that is available to a liquid when it is at a certain height. If you let it discharge it can drive something useful like a turbine producing electricity.

Friction energy is the energy that is lost to the environment due to the movement of the liquid through pipes and fittings in the system.

Velocity energy is the energy that moving objects have. When a pitcher throws a baseball he gives it velocity energy. When water comes out of a garden hose, it has velocity energy.

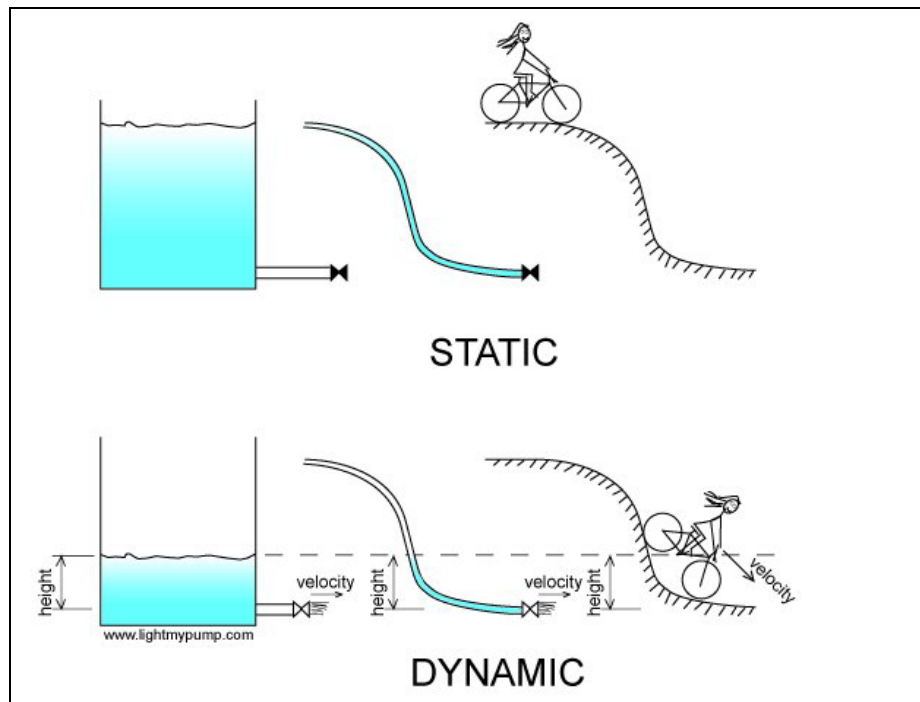

Figure 10 The relationship between height, pressure and velocity.

In the figure above we see a tank full of water, a tube full of water and a cyclist at the top of a hill. The tank produces pressure at the bottom and so does the tube. The cyclist has elevation energy that he will be using as soon as he moves.

As we open the valve at the tank bottom the fluid leaves the tank with a certain velocity, in this case pressure energy is converted to velocity energy. The same thing happens with the tube. In the case of the cyclist, the elevation energy is gradually converted to velocity energy.

The three forms of energy: elevation, pressure and velocity interact with each other in liquids. For solid objects there is no pressure energy because they don't extend outwards like liquids filling up all the available space and therefore they are not subject to the same kind of pressure changes.

The energy that the pump must supply is the friction energy plus the difference in height that the liquid must be raised to which is the elevation energy.

PUMP ENERGY = FRICTION ENERGY + ELEVATION ENERGY

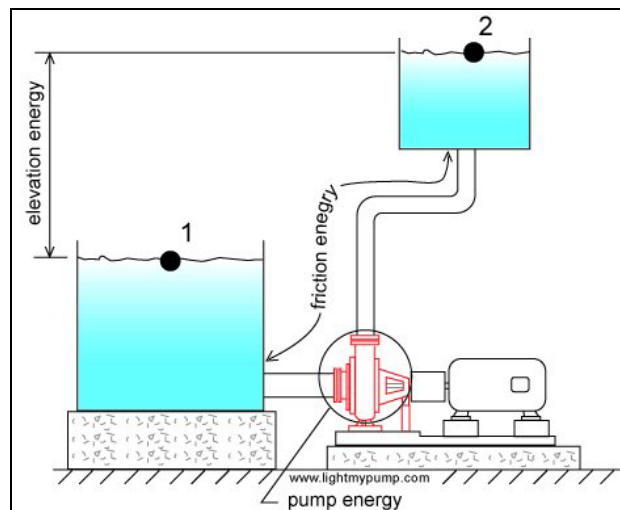

Figure 11 Pump energy equals elevation energy plus friction energy.

You are probably thinking where is the velocity energy in all this. Well if the liquid comes out of the system at high velocity then we would have to consider it but this is not a typical situation and we can neglect this for the systems discussed in this article. The last word on this topic, it is actually the velocity energy difference that we would need to consider. In Figure 11 the velocities at point 1 and point 2 are the result of the position of the fluid particles at points 1 and 2 and the action of the pump. The difference between these two velocity energies is an energy deficiency that the pump must supply but as you can see the velocities of these two points will be quite small.

Now what about head? Head is actually a way to simplify the use of energy. To use energy we need to know the weight of the object displaced.

Elevation energy E.E. is the weight of the object W times the distance d:

$$EE = W \times d$$

Friction energy FE is the force of friction F times the distance the liquid is displaced or the pipe length l:

$$FE = F \times l$$

Head is defined as energy divided by weight or the amount of energy used to displace a object divided by its weight. For elevation energy, the elevation head EH is:

$$EH = W \times d / W = d$$

For friction energy, the friction head FH is the friction energy divided by the weight of liquid displaced:

$$FH = FE/W = F \times l / W$$

The friction force F is in pounds and W the weight is also in pounds so that the unit of friction head is feet. This represents the amount of energy that the pump has to provide to overcome friction.

I know you are thinking: "...this doesn't make sense", how can feet represent energy?

If I attach a tube to the discharge side of a pump, the liquid will rise in the tube to a height that exactly balances the pressure at the pump discharge. Part of the height of liquid in the tube is due to the elevation height required (elevation head) and the other is the friction head and as you can see both can be expressed in feet and this is how you can measure them.

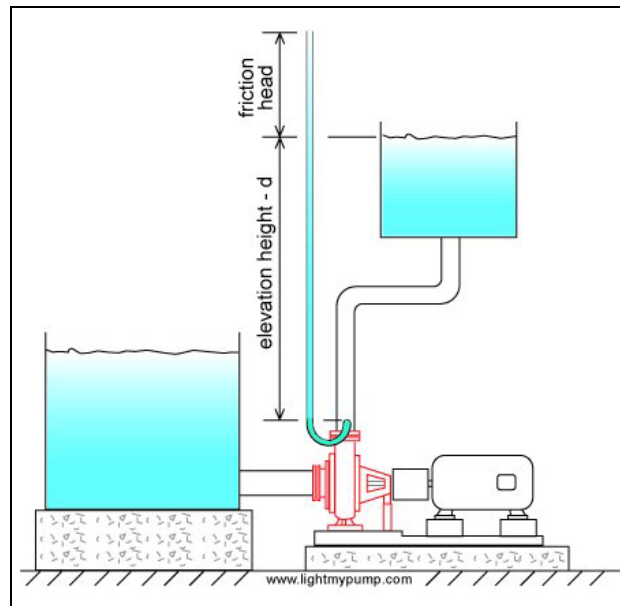

Figure 12 Measuring elevation head and friction head.

5. Static head

Webster's dictionary definition of head is: "a body of water kept in reserve at a height".

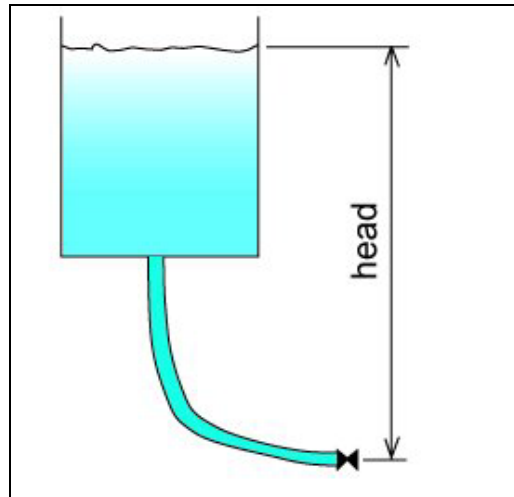

Figure 13 The definition of head.

It is expressed in terms of feet in the Imperial system and meters in the metric system. Because of its height and weight the fluid produces pressure at the low point and the higher the reservoir the higher the pressure (see Figure 13).

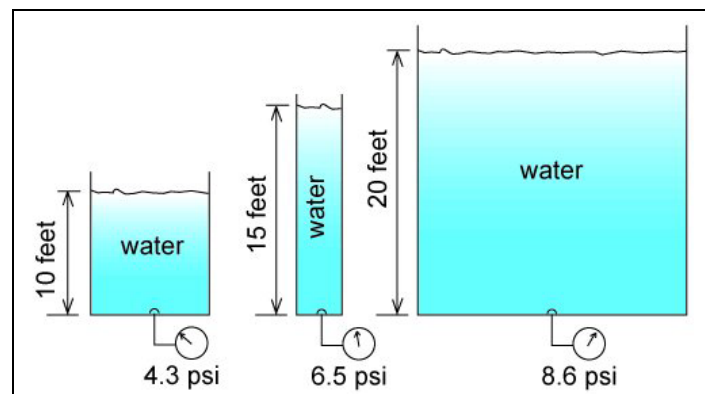

Figure 14 Pressure depends on the height of the liquid surface.

The amount of pressure at the bottom of a reservoir is independent of its shape, for the same liquid level, the pressure at the bottom will be the same. This is important since in complex piping systems it will always be possible to know the pressure at the bottom if we know the height (see Figure 15). To find out how to calculate pressure from height go to section 14.

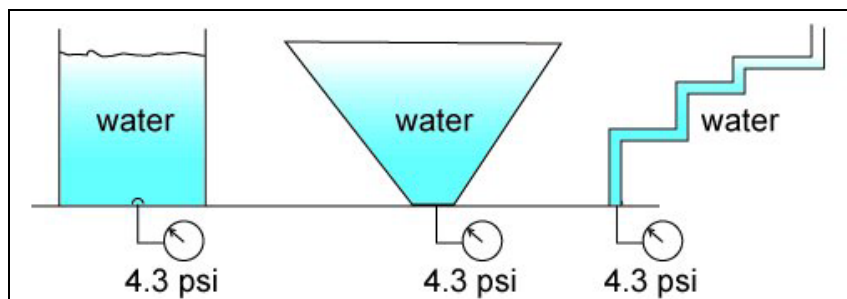

Figure 15 The pressure level at the bottom of a tank depends on the liquid surface height.

When a pump is used to displace a liquid to a higher level it is usually located at the low point or close to it. The head of the reservoir, which is called static head, will produce pressure on the pump that will have to be overcome once the pump is started.

To distinguish between the pressure energy produced by the discharge tank and suction tank, the head on the discharge side is called the discharge static head and on the suction side the suction static head (see Figure 16).

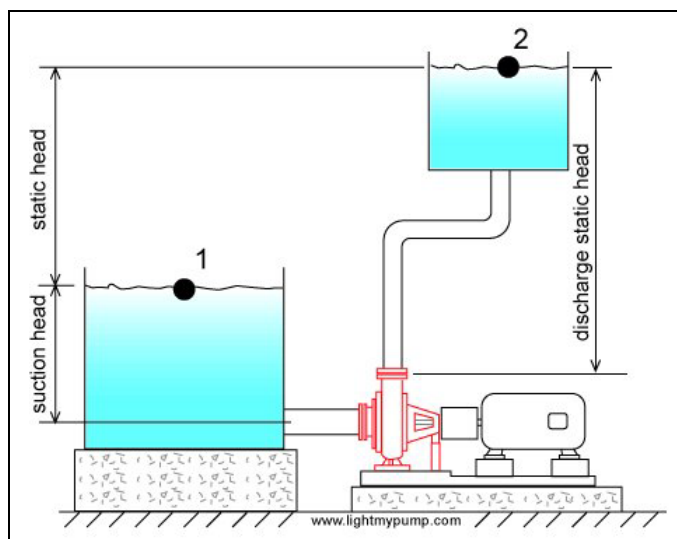

Figure 16 The static head on the pump when the suction tank is full.

Usually the liquid is from a suction tank displaced to a discharge tank. The suction tank fluid provides pressure energy to the pump that helps the pump. We want to know how much pressure energy the pump itself must supply so therefore we subtract the pressure energy provided by the suction tank. The static head is then the difference in height of the discharge tank fluid surface minus the suction tank fluid surface. Static head is sometimes called total static head to indicate that the pressure energy available on both sides of the pump has been considered (see Figure 16).

Since there is a difference in height between the suction and discharge flanges or connections of a pump by convention it was decided that the static head would be measured with respect to the suction flange elevation (see Figure 17).

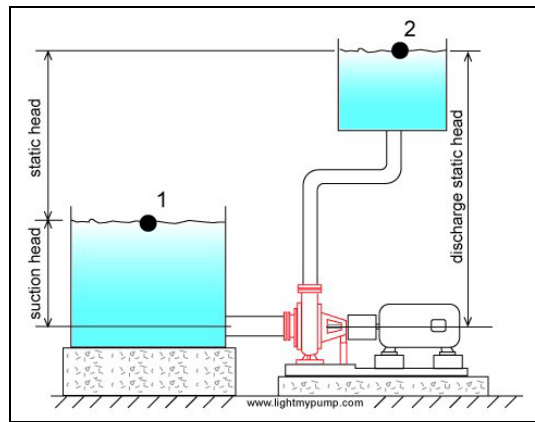

Figure 17 The static head on the pump is measured with respect to the pump suction.

end is open to atmosphere then the static head is measured with respect to the pipe end (see Figure 18).

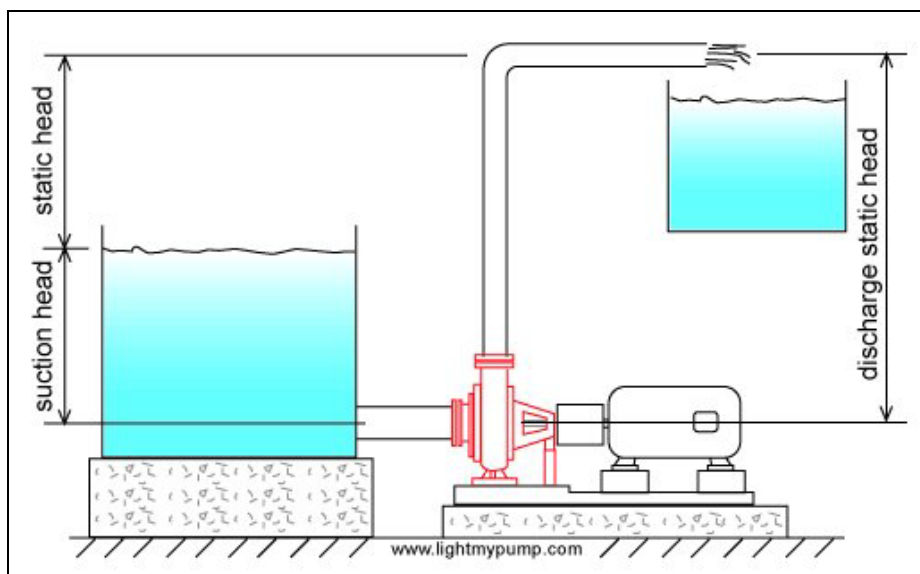

Figure 18 The static head on the pump with the discharge pipe end open to atmosphere.

Sometimes the discharge pipe end is submerged such as in Figure 19, then the static head will be the difference in elevation between the discharge tank fluid surface and suction tank fluid surface. Since the fluid in the system is a continuous medium and all fluid particles are connected via pressure, the fluid particles that are located at the surface of the discharge tank will contribute to the pressure built up at the pump discharge. Therefore the discharge surface elevation is the height that must be considered for static head. Avoid the mistake of using the discharge pipe end as the elevation for calculating static head if the pipe end is submerged (see Figure 20).

Note: if the discharge pipe end is submerged then a check valve on the pump discharge is required to avoid backflow when the pump is stopped.

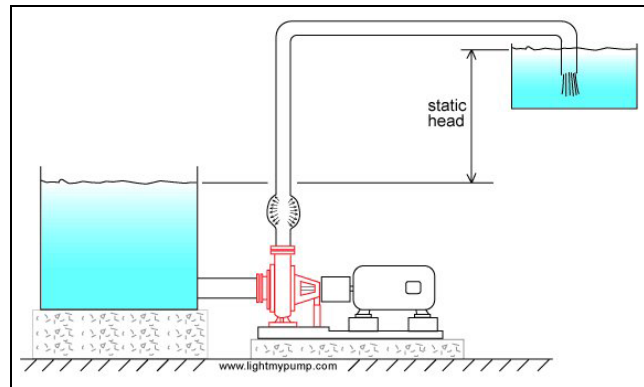

Figure 19 The height of the discharge pipe end is in this case the correct height for static head.

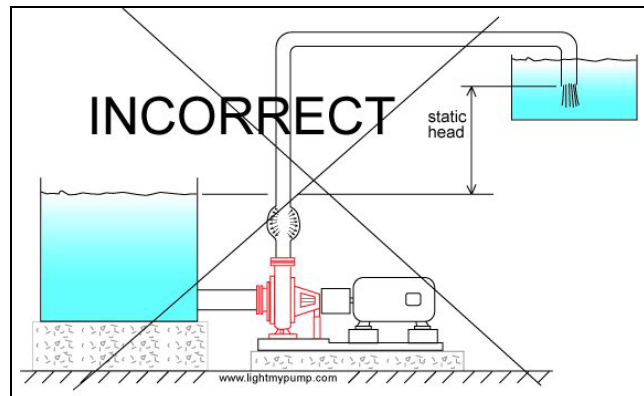

Figure 20 Incorrect difference in elevation for static head.

You can change the static head by raising the surface of the discharge tank (assuming the pipe end is submerged) or suction tank or both. All of these changes will influence the flow rate.



To correctly determine the static head follow the liquid particles from start to finish, the start is almost always at the liquid surface of the suction tank, this is called the inlet elevation. The end will occur where you encounter an environment with a fixed pressure such as the open atmosphere, this point is the discharge elevation end or outlet elevation. The difference between the two elevations is the static head. The static head can be negative because the outlet elevation can be lower than the inlet elevation.

6. Flow rate depends on elevation difference or static head

For identical systems, the flow rate will vary with the static head. If the pipe end elevation is high, the flow rate will be low (see Figure 21). Compare this to a cyclist on a hill with a slight upward slope, his velocity will be moderate and correspond to the amount of energy he can supply to overcome the friction of the wheels on the road and the change in elevation.

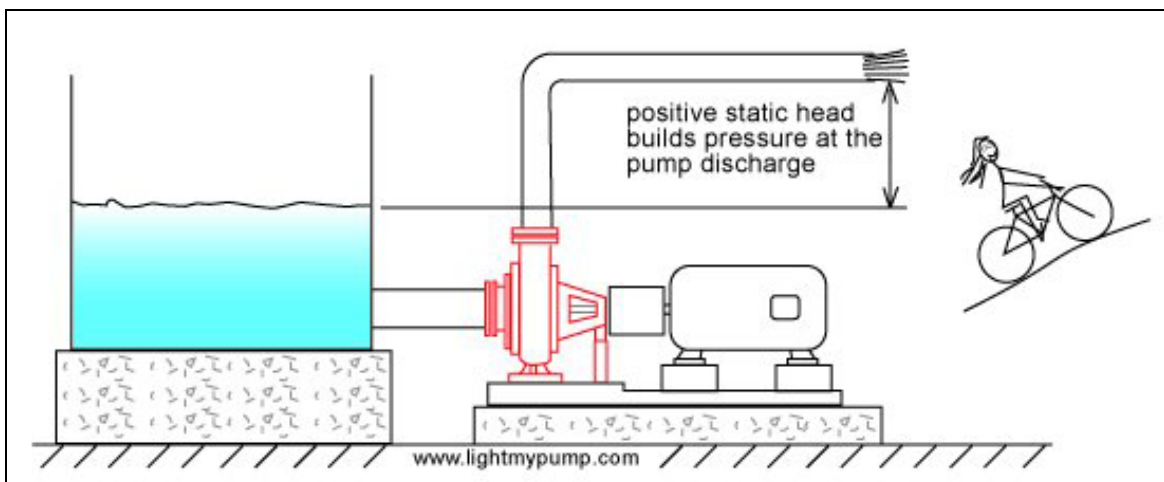

Figure 21 The effect of pipe end elevation on flow.

If the liquid surface of the suction tank is at the same elevation as the discharge end of the pipe then the static head will be zero and the flow rate will be limited by the friction in the system. This is equivalent of a cyclist on a flat road, his velocity depends on the amount of friction between the wheels and the road and the air resistance (see Figure 22).

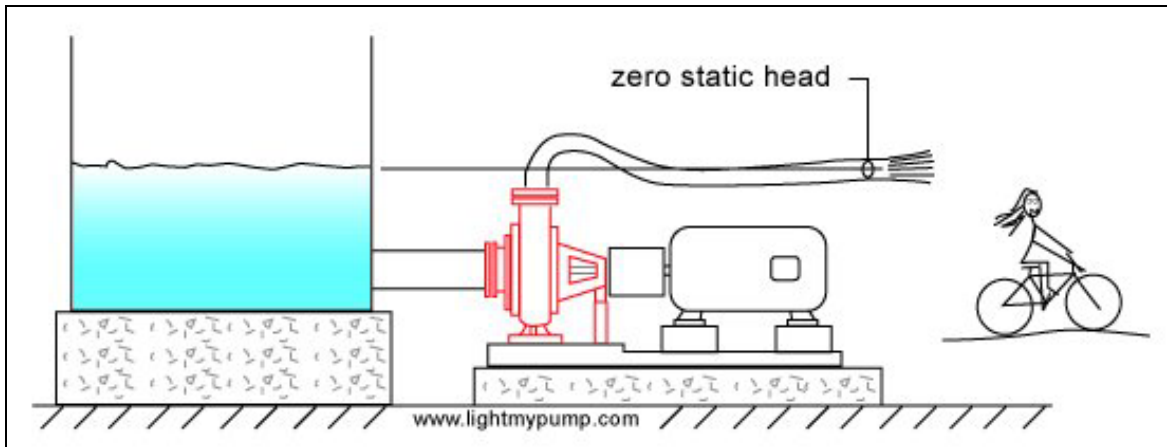

Figure 22 Flow rate is limited by friction in the system when the static head is zero.

In Figure 23, the discharge pipe end is raised vertically until the flow stops, the pump cannot raise the fluid higher than this point and the discharge pressure is at its maximum. Similarly the cyclist applies maximum force to the pedals without getting anywhere.

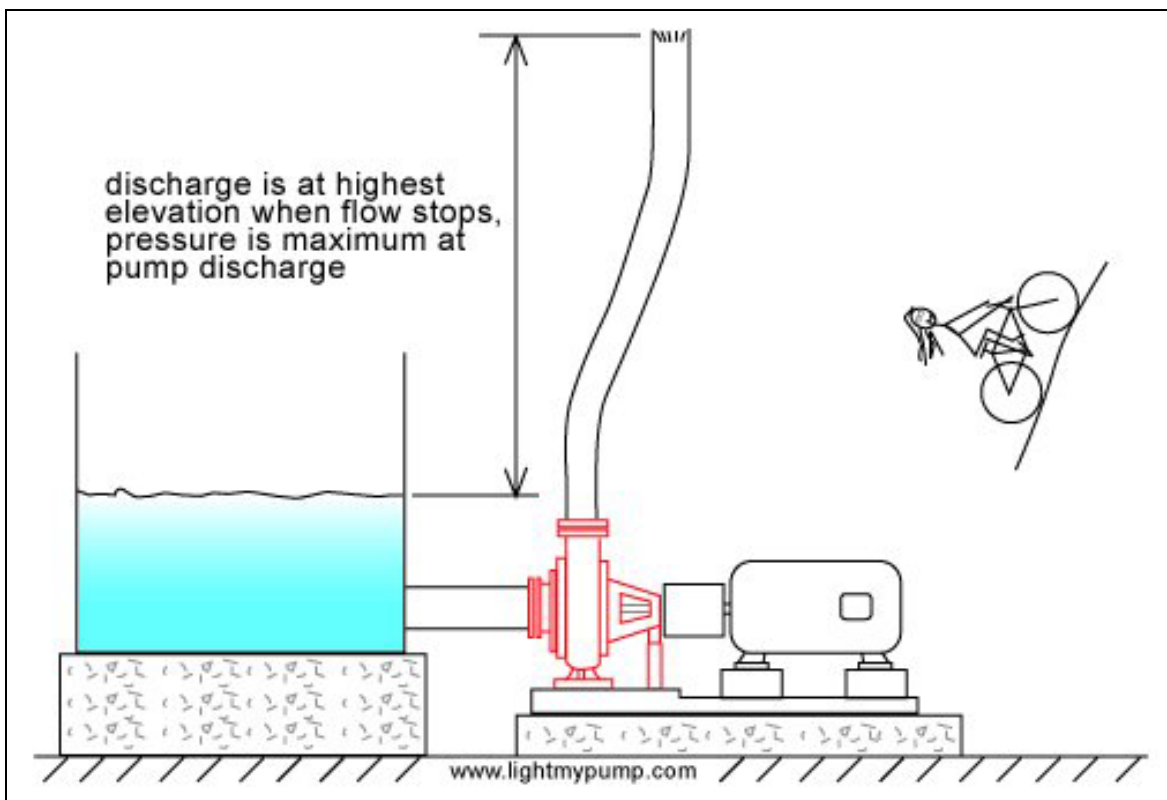

Figure 23 The pump produces zero flow at its maximum outlet pressure.

If the discharge pipe end is lower than the liquid surface of the suction tank then the static head will be negative and the flow rate high (see Figure 24). If the negative static

head is large then it is possible that a pump is not required since the energy provided by the difference in elevation may be sufficient to move the fluid through the system without the use of a pump as in the case of a siphon (see the pump glossary). By analogy, as the cyclist comes down the hill he loses his stored elevation energy which is transformed progressively into velocity energy. The lower he is on the slope, the faster he goes.

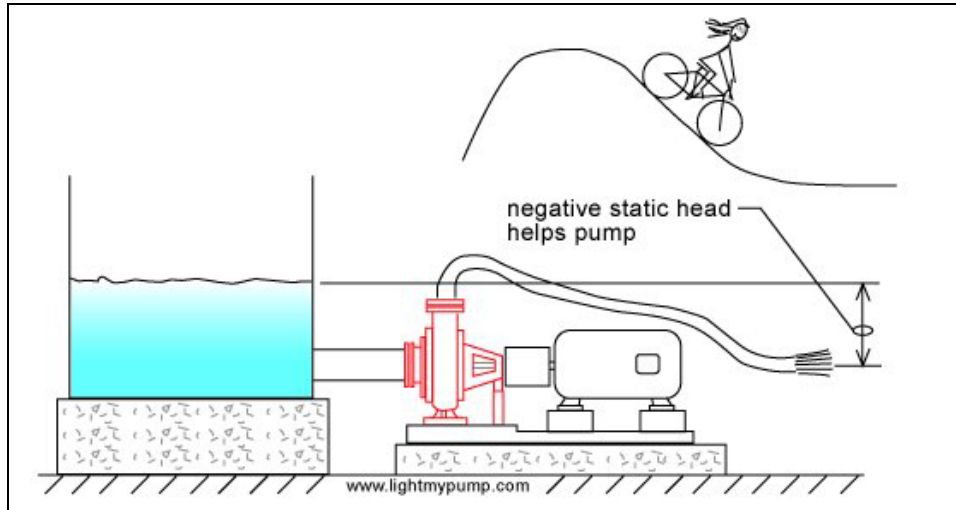

Figure 24 Negative static head increases flow rate.

Pumps are most often rated in terms of head and flow. In Figure 23, the discharge pipe end is raised to a height at which the flow stops, this is the head of the pump at zero flow. We measure this difference in height in feet (see Figure 25). Head varies depending on flow rate, but in this case since there is no flow and hence no friction, the head of the pump is THE MAXIMUM HEIGHT THAT THE FLUID CAN BE LIFTED TO WITH RESPECT TO THE SURFACE OF THE SUCTION TANK. Since there is no flow the head (also called total head) that the pump produces is equal to the static head.

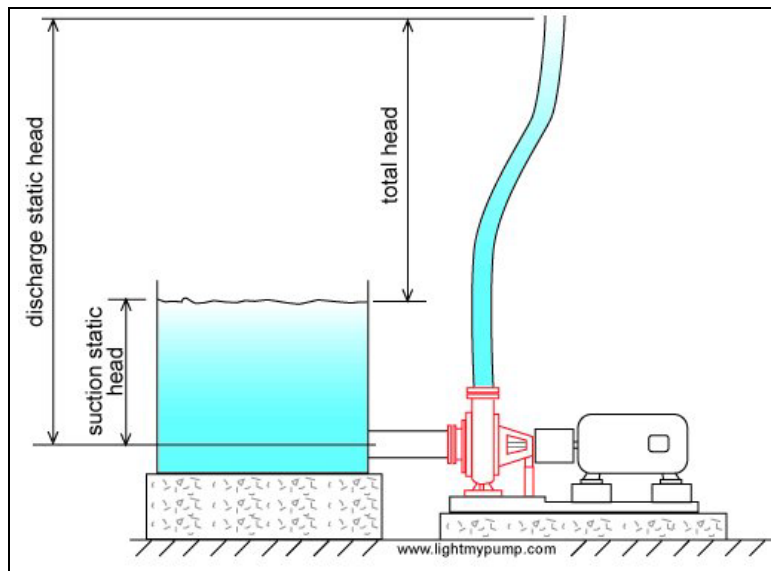

Figure 25 Highest possible total head of a pump.

In this situation the pump will deliver its maximum pressure. If the pipe end is lowered as in Figure 21, the pump flow will increase and the head (also known as total head) will decrease to a value that corresponds to the flow. **Why?** Let's start from the point of zero flow with the pipe end at its maximum elevation, the pipe end is lowered so that flow begins. If there is flow there must be friction, the friction energy is subtracted (because it is lost) from the maximum total head and the total head is reduced. At the same time the static head is reduced which further reduces the total head.

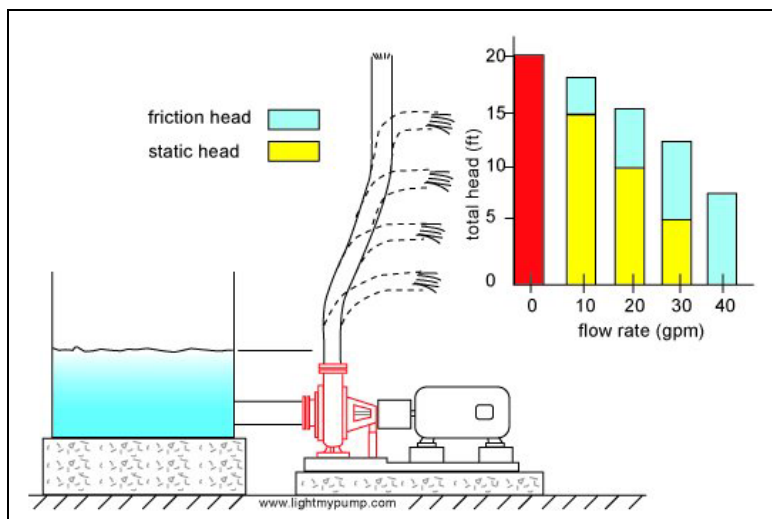

Figure 26 Variation of total head vs. pipe end elevation or static head.

When you buy a pump you don't specify the maximum total head that the pump can deliver since this occurs at zero flow. You instead specify the total head that occurs at your required flow rate. This head will depend on the maximum height you need to reach with respect to the suction tank fluid surface and the friction loss in your system.

For example, if your pump is supplying a bathtub on the 2nd floor, you will need enough head to reach that level, that will be your static head, plus an additional amount to overcome the friction loss through the pipes and fittings. Assuming that you want to fill the bath as quickly as possible, then the taps on the bath will be fully open and will offer very little resistance or friction loss. If you want to supply a shower head for this bathtub then you will need a pump with more head for the same flow rate because the shower head is higher and offers more resistance than the bathtub taps.

Luckily, there are many sizes and models of centrifugal pumps and you cannot expect to purchase a pump that matches exactly the head you require at the desired flow. You will probably have to purchase a pump that provides slightly more head and flow than you require and you will adjust the flow with the use of appropriate valves.

Note: you can get more head from a pump by increasing its speed or impeller diameter or both. In practice, homeowners cannot make these changes and to obtain a higher total head, a new pump must be purchased.

7. Flow rate depends on friction

For identical systems, the flow rate will vary with the size and diameter of the discharge pipe. A system with a discharge pipe that is generously sized will have a high flow rate. This is what happens when you use a large drain pipe on a tank to be emptied, it drains very fast.

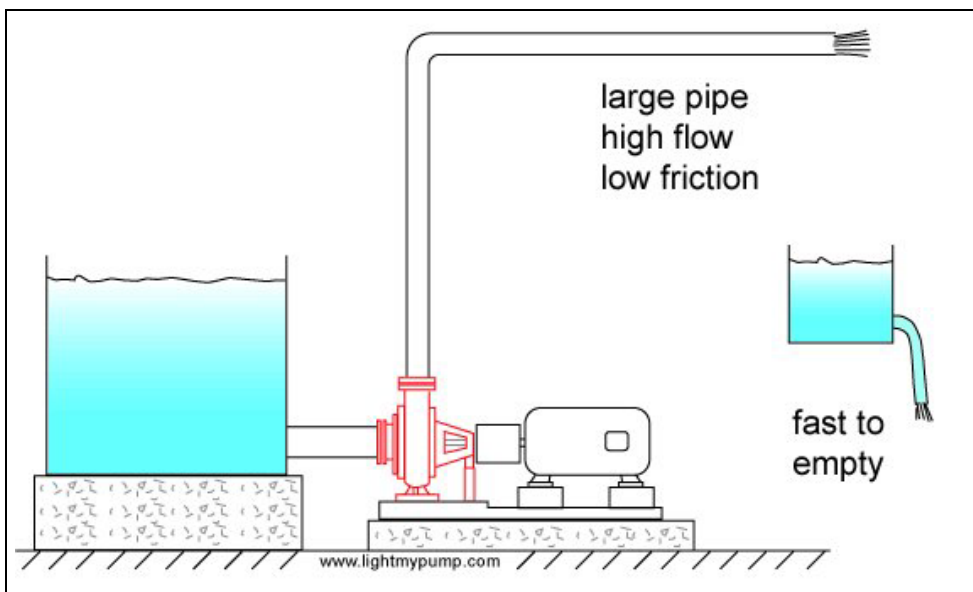

Figure 27 A large pipe produces low friction.

The smaller the pipe, the less the flow. How does the pump adjust itself to the diameter of the pipe, after all it does not know what size pipe will be installed? The pump you install is designed to produce a certain average flow for systems that have their pipes sized accordingly. The impeller size and its speed predispose the pump to supply the liquid at a certain flow rate. If you attempt to push that same flow through a small pipe the discharge pressure will increase and the flow will decrease. Similarly if you try to empty a tank with a small tube, it will take a long time to drain (see Figure 28).

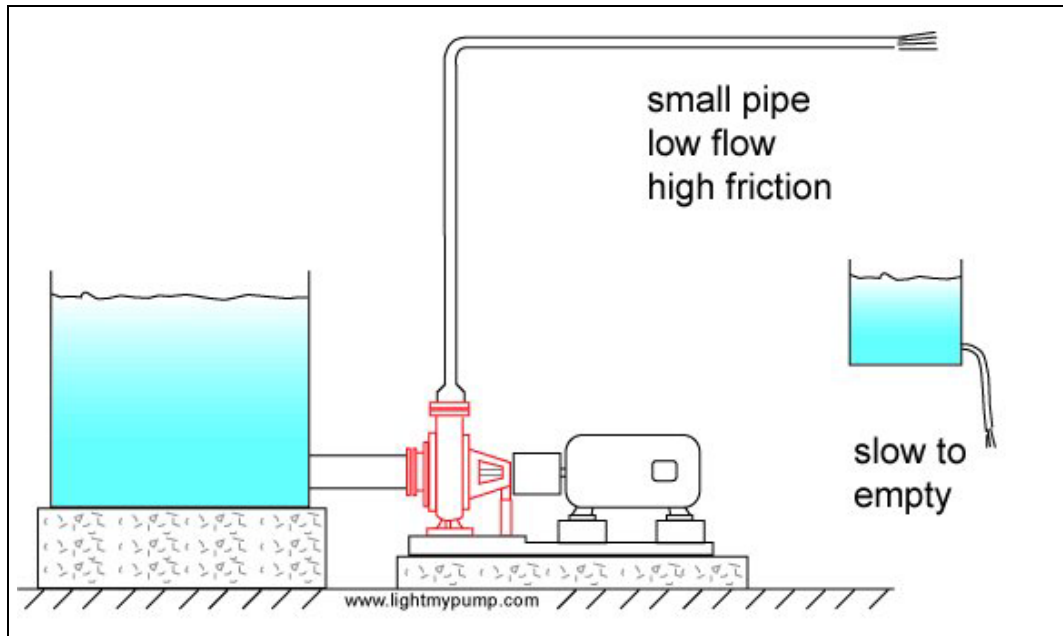

Figure 28 A small pipe produces high friction.

when the discharge pipe is long, the friction will be high and the flow rate low (see Figure 29) and if the pipe is short the friction will be low and the flow rate high (see Figure 30)

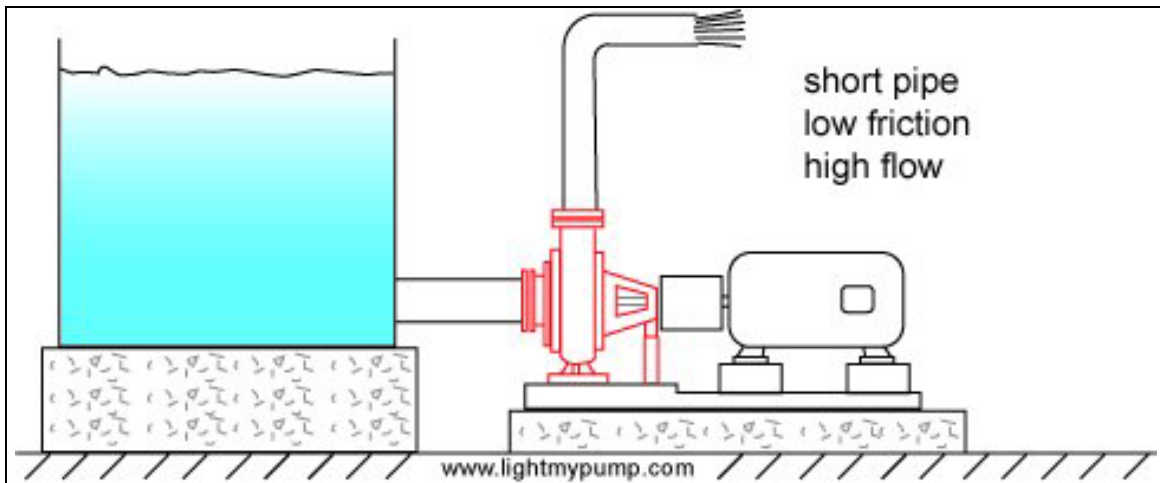

Figure 29 A long pipe produced high friction.

Later on in the tutorial, a chart will be presented giving the size of pipes for various flow rates.

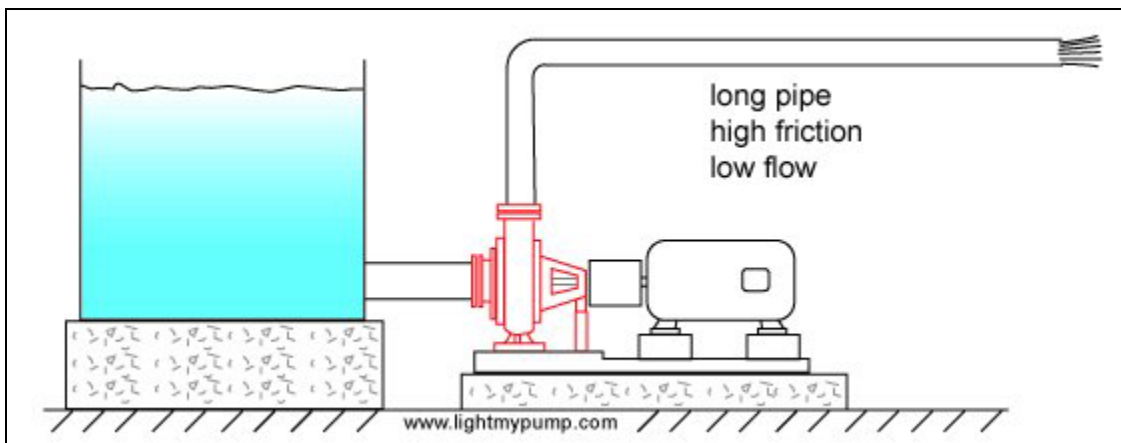

Figure 30 A short pipe produces low friction.

8. How does a centrifugal pump produce pressure

Fluid particles enter the pump at the suction flange or connection. They then turn 90 degrees into the plane of the impeller and fill up the volume between each impeller vane. The next image shows what happens to the fluid particles from that point forward for an animated version go to <http://www.fluidedesign.com/downloads.htm> in the middle of the page.

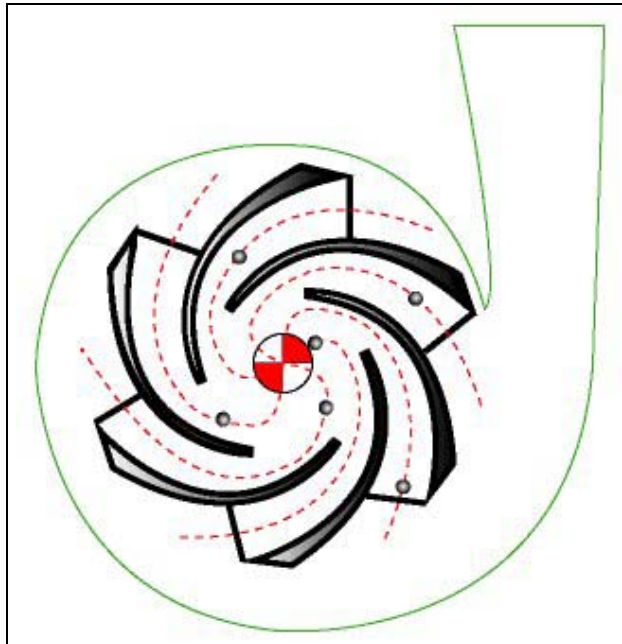

Figure 31 Fluid particle paths in a centrifugal pump.

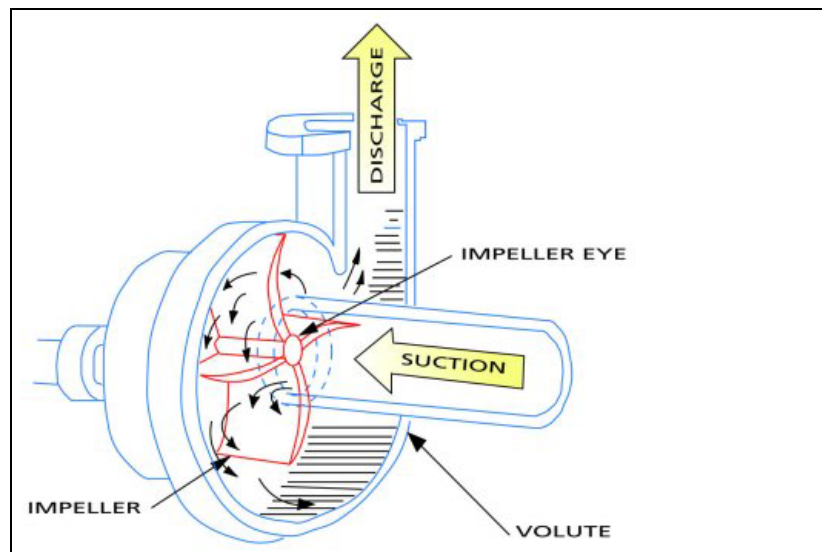

Figure 32 Different parts of a centrifugal pump.

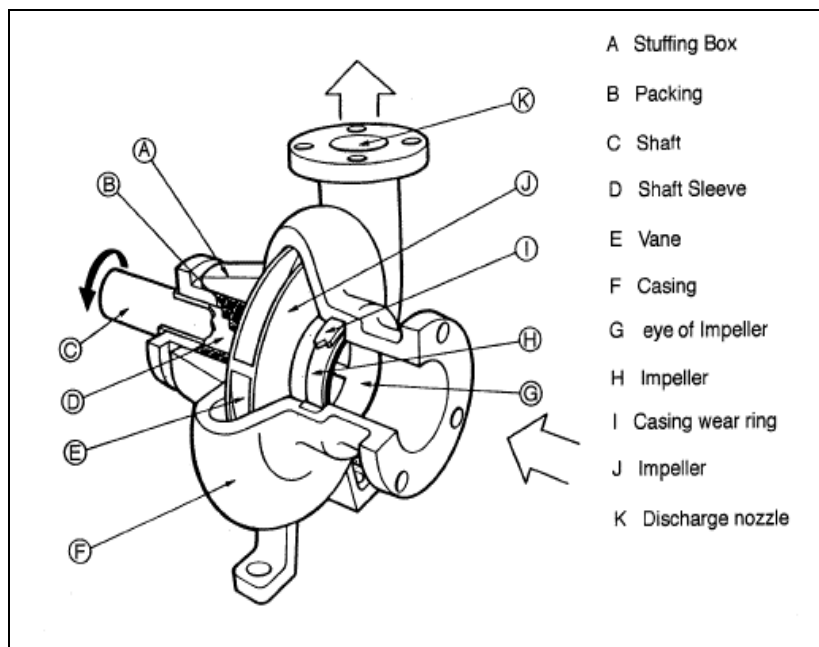

Figure 33 Cut-away view of a centrifugal pump.

A centrifugal pump is a device whose purpose is to produce pressure by accelerating fluid particles to a high velocity providing them with velocity energy. What is velocity energy? It's a way to express how the velocity of objects can affect other objects, you for example. Have you ever been tackled in a football match? The velocity at which the other player comes at you determines how hard you are hit. The mass of the player is also an important factor. The combination of mass and velocity produces velocity energy. Another example is catching a hard baseball pitch, ouch, there can be a lot of velocity in a small fast moving baseball. Fluid particles that move at high speed have velocity energy, just put your hand on the open end of a garden hose.

The fluid particles in the pump are expelled from the tips of the impeller vanes at high velocity, they then hit the inner casing of the pump and are decelerated lowering the velocity energy and raising the pressure energy. Unlike friction that wastes energy, the decrease in velocity energy serves to increase pressure energy; this is the principle of energy conservation in action. The same thing happens to a cyclist that starts at the top of a hill, his speed gradually increases as he loses elevation. The cyclist's elevation energy is transformed into velocity energy; in the pump's case the velocity energy is transformed into pressure energy.

Try this experiment, find a plastic cup or other container that you can poke a small pinhole in the bottom. Fill it with water and attach a string to it, and now you guessed it, start spinning.

The faster you spin, the more water comes out the small hole, the water is pressurized inside the cup using centrifugal force in a similar fashion to a centrifugal pump. In the case of a pump, the rotational motion of the impeller projects fluid particles at high speed into the volume between the casing wall and the impeller tips. Prior to leaving the pump, the fluid particles slow down to the velocity at the inlet of the discharge pipe (see Figures 31 and 32) which will be the same velocity throughout the system if the pipe diameter does not change.

How does the flow rate change when the discharge pipe end elevation is changed or when there is an increase or decrease in pipe friction? These changes cause the pressure at the pump outlet to increase when the flow decreases, sounds backwards doesn't it. Well it's not and you will see why. How does the pump adjust to this change in pressure? Or in other words, if the pressure changes due to outside factors, how does the pump respond to this change.

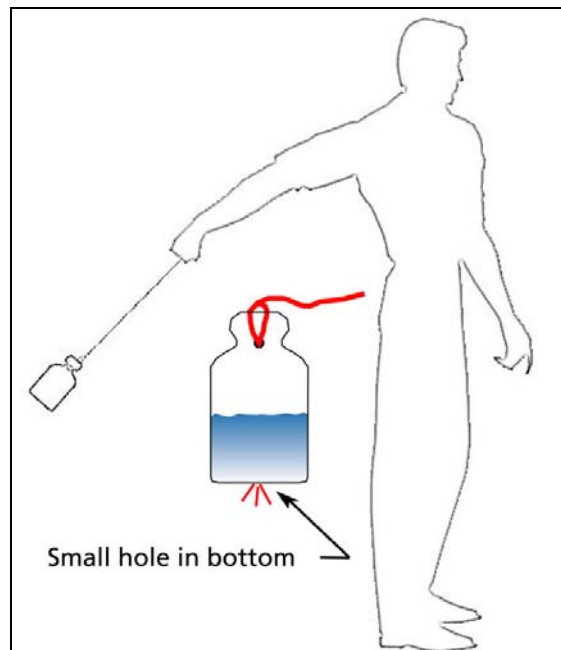

Figure 34 An experiment with centrifugal force.



Pressure is produced by the rotational speed of the impeller vanes. The speed is constant. The pump will produce a certain discharge pressure corresponding to the particular conditions of the system (for example, fluid viscosity, pipe size, elevation difference, etc.). If changing something in the system causes the flow to decrease (for example closing a discharge valve), there will be an increase in pressure at the pump discharge **because there is no corresponding reduction in the impeller speed**. The pump produces excess velocity energy because it operates at constant speed, the excess velocity energy is transformed into pressure energy and the pressure goes up.

All centrifugal pumps have a performance or characteristic curve that looks similar to the one shown in Figure 35 (assuming that the level in the suction tank remains constant), this shows how the discharge pressure varies with the flow rate through the pump.

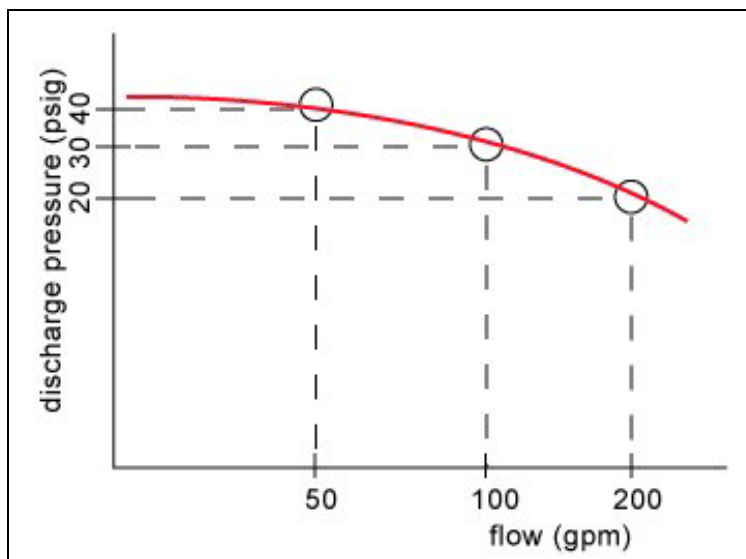

Figure 35 Typical curve of discharge pressure vs. flow rate for a pump.

At 200 gpm, this pump produces 20 psig discharge pressure, and as the flow drops the pressure increases, and will be 40 psig at zero flow.

Note: this applies to centrifugal pumps, many home owners have positive displacement pumps, often piston pumps. These pumps produce constant flow no matter what changes are made to the system. This is why all such pump have an internal relief valve that opens to relieve pressure and protect the pump from excessive pressure cause by the closing of a water tap for example. Also typically, the pump has a pressure switch that shuts the motor down when the pressure gets too high saving energy in the process.

9. What is total head

Total head and flow are the main criteria that are used to compare one pump with another or to select a centrifugal pump for an application. Total head is related to the discharge pressure of the pump. Why can't we just use discharge pressure? Pressure is a familiar concept, we are familiar with it in our daily lives. For example, fire extinguishers are pressurized at 60 psig (410 kPa), we put 35 psig (240 kPa) air pressure in our bicycle and car tires. Pump manufacturers do not use discharge pressure as criteria for pump selection. One of the reasons is that they do not know how you will use the pump. They do not know what flow rate you require and the flow rate of a centrifugal pump is not fixed as it is in a positive displacement pump. The discharge pressure depends on the pressure available on the suction side of the pump. If the source of water for the pump is below or above the pump suction, for the same flow rate you will get a different discharge pressure. Therefore to eliminate this problem, it is preferable to use the difference in pressure between the inlet and outlet of the pump.

Pump manufacturers have taken this a step further, the amount of pressure that a pump can produce will depend on the density of the fluid, for a salt water solution which is denser than pure water, the pressure will be higher for the same flow rate. Once again, the manufacturer doesn't know what type of fluid is in your system, so that a criteria that

does not depend on density is very useful. There is such a criteria and it is called TOTAL HEAD, and this is defined as the difference in head between the inlet and outlet of the pump.

You can measure the discharge head by attaching a tube to the discharge side of the pump and measuring the height of the liquid in the tube with respect to the suction of the pump. The tube will have to be quite high for a typical domestic pump. If the discharge pressure is 40 psi the tube would have to be 92 feet high. This is not a practical method but it helps explain how head relates to total head and how head relates to pressure. You do the same to measure the suction head. The difference between the two is the total head of the pump.

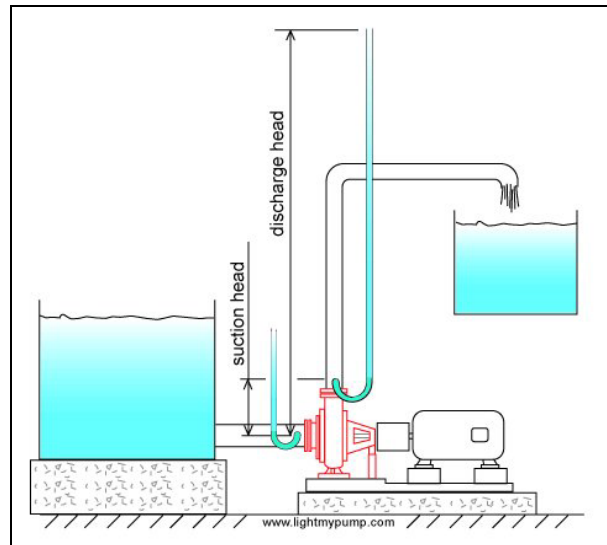

Figure 36 A method for measuring total head.

For these reasons the pump manufacturers have chosen total head as the main parameter that describes the pump's available energy.



The fluid in the measuring tube of the discharge or suction side of the pump will rise to the same height for all fluids regardless of the density.

This is a rather astonishing statement, here's why. The pump doesn't know anything about head, head is a concept we use to make our life easier. The pump produces pressure and the difference in pressure across the pump is the amount of pressure energy available to the system. If the fluid is dense, such as a salt solution for example, more pressure will be produced at the pump discharge than if the fluid were pure water. Compare two tanks with the same cylindrical shape, the same volume and liquid level, the tank with the denser fluid will have a higher pressure at the bottom. But the static head of the fluid surface with respect to the bottom is the same. Total head behaves the same way as static head, even if the fluid is denser the total head as compared to a less dense fluid such as pure water will be the same. This is a surprising fact, see this experiment on video on the web that shows this idea in action (<http://www.fluidedesign.com/video1.htm#vid0.9>).

10. What is the relationship between head and total head

Total head is the height that the liquid is raised to at the discharge side of the pump less the height that the liquid is raised to at the suction side (see Figure 36). Why less the height at the suction side? Because we want the energy contribution of the pump only and not the energy that is supplied to it.

What is the unit of head? First let's deal with the unit of energy. Energy can be expressed in foot-pounds which is the amount of force required to lift an object up multiplied by the vertical distance. A good example is weight lifting. If you lift 100 pounds (445 Newtons) up 6 feet (1.83 m), the energy required is $6 \times 100 = 600$ ft-lbf (814 N-m). Head is defined as energy divided by the weight of the object displaced. For the weight lifter, the energy divided by the weight displaced is $6 \times 100 / 100 = 6$ feet (1.83 m), so the amount of energy per pound of dumbbell that the weight lifter needs to provide is 6 feet. This is not terribly useful to know for a weight lifter but we will see how very useful it is for displacing fluids.



Figure 37 Energy is required to lift weights.

You may be interested to know that 324 foot-pounds of energy is equivalent to 1 calorie. This means that our weight lifter spends $600/324 = 1.8$ calories each time he lifts that weight up 6 feet, not much is it.

The following figure shows how much energy is required to displace vertically one gallon of water.

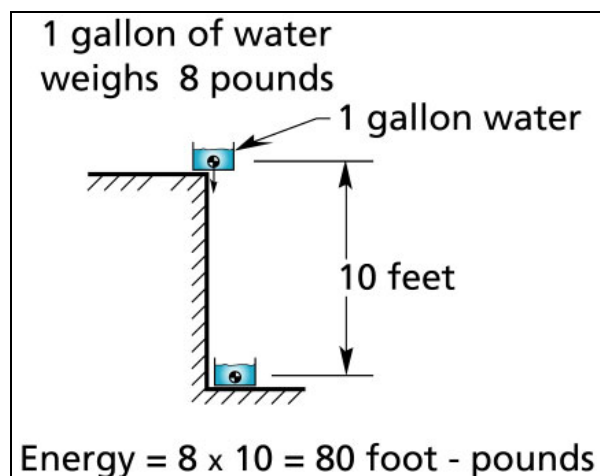

Figure 38 Energy required to lift 1 gallon of water up 10 feet.

This next figure shows how much head is required to do the same job.

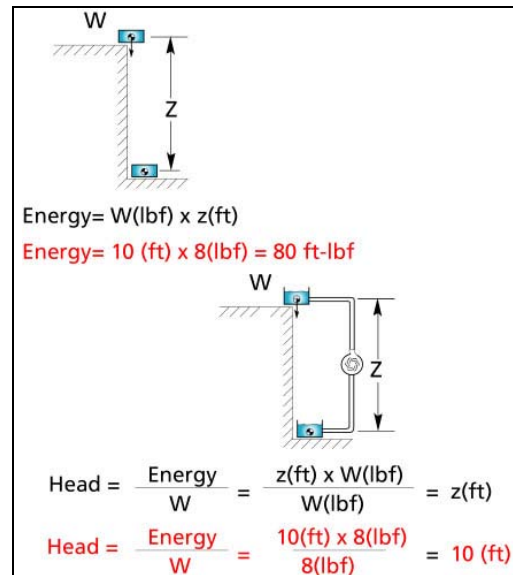

Figure 39 Head vs. energy.

If we use energy to describe how much work the pump needs to do to displace a volume of liquid, we will need to know the weight. If we use head, we only need to know the vertical distance of movement. This is very useful for fluids because pumping is a continuous process, usually when you pump you leave the pump on for a long time, you don't worry about how many pounds of fluid have been displaced we are mainly interested in the flow rate.

The other very useful aspect of using head is that the elevation difference or static head can be used directly as one part of the value of total head, the other part being friction head as shown in Figure 40.

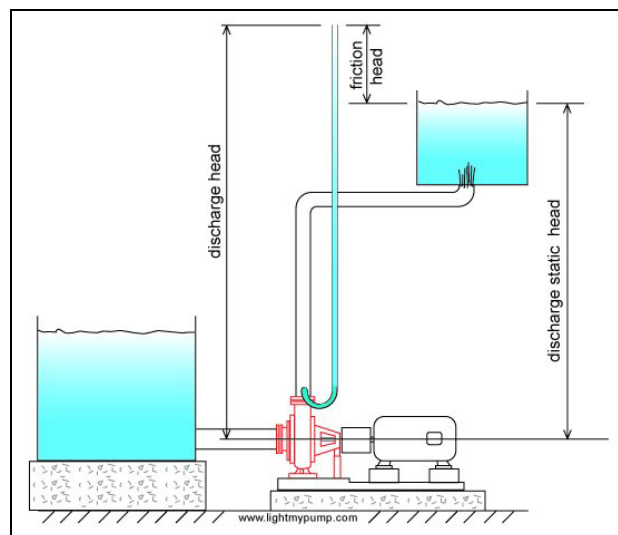

Figure 40 Discharge static head plus friction head equals pump discharge head.

How much static head is required to pump water up from the ground floor to the second floor, or 15 feet up? Remember that you must also take into consideration the level of the water in the suction tank. If the water level is 10 feet below the pump suction connection then the static head will be $10 + 15 = 25$ feet. Therefore the total head will have to be at least 25 feet plus the friction head loss of the fluid moving through the pipes.

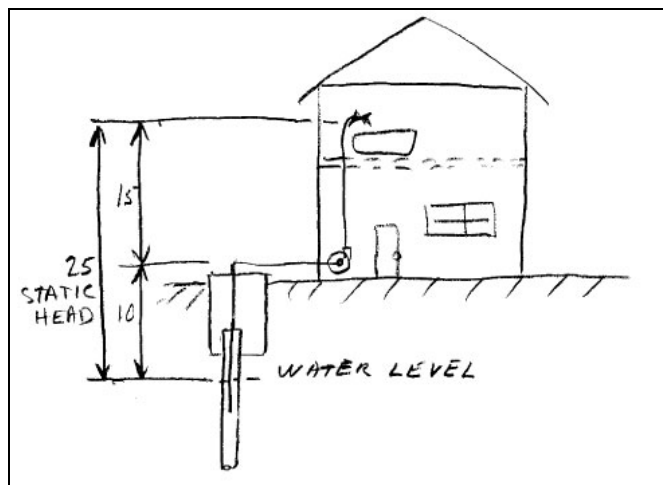

Figure 41 Static head.

11. How to determine friction head

Friction head is the amount of energy loss due to friction caused by fluid movement through pipes and fittings. It takes a force to move the fluid against friction, in the same way that a force is required to lift a weight. The force is exerted in the same direction as the moving liquid and energy is expended. In the same way that head was calculated to lift a certain weight, the friction head is calculated with the force required to overcome friction times the displacement (pipe length) divided by the weight of fluid displaced. These calculations have been done for us and you can find the values for friction head loss in Table 2 for different pipe sizes and flow rates.

Flow rate and friction head loss for tubing and pipe sizes (Imperial) (based on 10 ft/s velocity)			
Nom. dia. (in)	Inside dia. (in)	Flow rate (gpm)	Friction head loss (ft of head per feet pipe)
1/4	0.311	2.4	2.15
1/2	0.527	6.8	1.08
3/4	0.745	13.6	0.69
1	0.995	24	0.48
1 1/2	1.6	63	0.26
2	2.067	105	0.19
2 1/2	2.469	149	0.15
3	3.068	230	0.117
4	4.026	400	0.084
6	6.065	900	0.051
8	8.125	1615	0.036
10	10.25	2570	0.027
12	12.25	3675	0.022
14	13.5	4460	0.0194

Table 2

Table 2 gives the flow rate and the friction head loss for water being moved through pipes of different diameter at a velocity of 10 ft/s. I have chosen 10 ft/s because it is a typical value for velocity in pipes, it is not too large which would create a lot of friction and not too small which would slow things down, it's just right. Velocity depends on the flow rate and the pipe diameter, you will find friction loss charts for flow rates of 5 ft/s and 15 ft/s in Appendix A, imperial and metric. If you wish to do your own calculation of velocity, you can find out how in Appendix D.

If the velocity you are using is less than 10 ft/s then the friction loss will be less and if the velocity is higher the loss will be greater. A velocity of 10 ft/s is normal practice for sizing pipes on the discharge side of the pump. For the suction side of the pump, it is desirable to be more conservative and size pipes for a lower velocity, for example between 4 and 7 feet/second. This is why you normally see a bigger pipe size on the suction side of the pump than on the discharge. A rule of thumb is to make the suction pipe the same size or one size larger than the suction connection of the pump.

Why bother with velocity, isn't flow rate enough information to describe fluid movement through a system. It depends how complicated your system is, if the discharge pipe has a constant diameter then the velocity throughout will be the same. Then if you know the flow rate, based on the friction loss tables, you can calculate the friction loss with the flow rate only. If the discharge pipe diameter changes then the velocity will change for the same flow rate and a higher or lower velocity means a higher or lower friction loss in that portion of the system. You will then have to use the velocity to calculate the friction head loss in this part of the pipe. You can find a velocity calculator at this web site <http://www.fluidedesign.com/applets.htm#applets4>.

Those who would like to do pipe friction calculations will find the information in Appendix B and pipe fittings friction loss calculations are in Appendix C. A calculator for pipe friction loss is available here (<http://www.fluidedesign.com/applets.htm#applets13>) and for fittings friction loss here(<http://www.fluidedesign.com/applets.htm#applets15>).

12. The performance or characteristic curve of the pump

The pump characteristic curve has a similar appearance to the previous curve of discharge pressure vs. flow (Figure 35). As I mentioned this is not a practical way of describing the performance because you would have to know the suction pressure used to generate the curve. Figure 42 shows a typical total head vs. flow rate characteristic curve. This is the type of curve that all pump manufacturers publish for each model pump for a given operating speed.

Not all manufacturers will provide you with the pump characteristic curve. However, the curve does exist and if you insist you can probably get it. Generally speaking the more you pay, the more technical information you get.

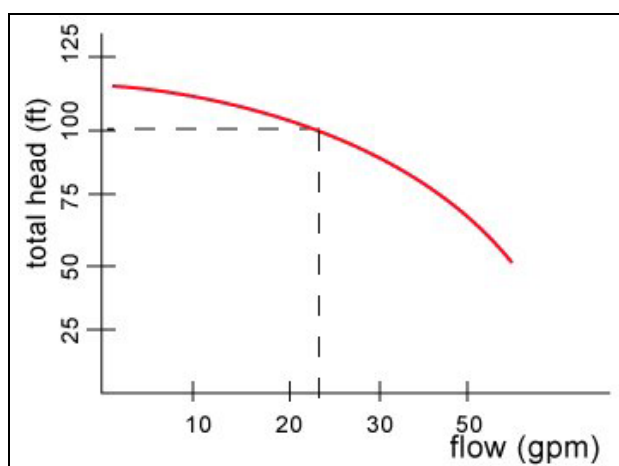

Figure 42 Characteristic curve of a pump.

13. Elevation changes between the suction tank surface and the discharge point can be disregarded

Surprising statement! You can have the discharge pipe going up or down (within reason) as much as you like and this has no effect on the static head of the system. The fluid loses its elevation energy as it goes up but regains it without loss as it comes back down. If the discharge elevation of the system does not change then any changes prior to this point will cancel out as you reach the discharge point of the system. What does make a difference is the length of pipe between these two points, by going up and down you increase the length of the pipe which increases the friction head which will increase the total head but the static head will remain the same.

There is a limit as to how high you can go in between the pump discharge and the pump system discharge point. This height will depend on the available shut-off head of the

pump. Shut-off head is the maximum head that a pump can produce at zero flow. When you start the pump in a system with fluid that is going upwards, the velocity in the pipe will be low until the fluid completely fills the system. When the system is filled equilibrium is reached between the pump's ability to push the fluid through the system and the resistance that the system offers, at this equilibrium the flow rate is established.

If the shut-off head is insufficient then there will be insufficient energy to get the liquid past the high point. If the shut-of head is high enough to get the liquid past the high point then the system can be filled up which results in a lowering of the static head allowing the pump to operate at a lower total head.

In the characteristic curve shown in Figure 42 the shut-off head is 125 feet. If your system has a high point higher than 125 feet between the suction surface and the high point then it will be impossible to fill this system up and operate it at the required flow rate.

13. How to select a centrifugal pump

It is unlikely that you can buy a centrifugal pump off the shelf, install it in an existing system and expect it to deliver exactly the flow rate you require. The flow rate that you obtain depends on the physical characteristics of your system such as friction which depends on the length and size of the pipes and elevation difference which depends on the building and location. The pump manufacturer has no means of knowing what these constraints will be. This is why buying a centrifugal pump is more complicated than buying a positive displacement pump which will provide its rated flow no matter what system you install it in.

The main factors that affect the flow rate of a centrifugal pump are:

- friction, which depends on the length of pipe and the diameter
- static head, which depends on the difference of the pipe end discharge height vs. the suction tank fluid surface height
- fluid viscosity, if the fluid is different than water.

The steps to follow to select a centrifugal pump are:

1. Determine the flow rate

To size and select a centrifugal pump, first determine the flow rate. If you are a home owner, find out which of your uses for water is the biggest consumer. In many cases, this will be the bathtub which requires approximately 10 gpm (0.6 L/s). In an industrial setting, the flow rate will often depend on the production level of the plant. Selecting the right flow rate may be as simple as determining that it takes 100 gpm (6.3 L/s) to fill a tank in a reasonable amount of time or the flow rate may depend on the interaction between processes.

2. Determine the static head

This is a matter of taking measurements of the height between the suction tank fluid surface and the discharge pipe end height or the discharge tank fluid surface elevation.

3. Determine the friction head

The friction head depends on the flow rate, the pipe size and the pipe length. This is calculated from the values in the tables presented here (see Table 2). For fluids different than water the viscosity will be an important factor and Table 1 is not applicable.

4. Calculate the total head

The total head is the sum of the static head (remember that the static head can be positive or negative) and the friction head.

5. Select the pump

You can select the pump based on the pump manufacturer's catalogue information using the total head and flow required as well as suitability to the application.

Example of total head calculation - Sizing a pump for a home owner application

Experience tells me that to fill a bath up in a reasonable amount of time, a flow rate of 10 gpm is required. According to Table 2, the copper tubing size should be somewhere between 1/2" and 3/4", I choose 3/4". I will design my system so that from the pump there is a 3/4" copper tube main distributor, there will be a 3/4" take-off from this distributor on the ground floor to the second floor level where the bath is located. On the suction, I will use a pipe diameter of 1", the suction pipe is 30 ft long.

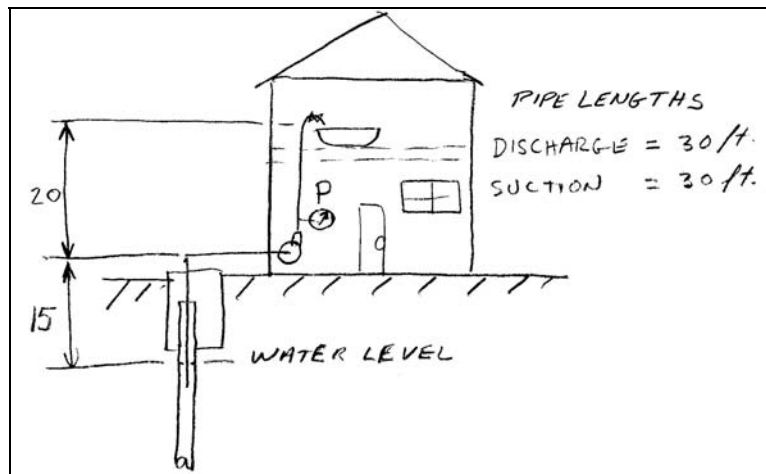

Figure 43 Typical domestic water system.

Friction loss on the suction side of the pump

According to calculation or the use of tables which is not presented here the friction loss for a 1" tube is has a friction loss of 0.068 feet per feet of pipe. In this case, the distance is 30 feet. The friction loss in feet is then $30 \times 0.068 = 2.4$ feet. There is some friction loss in the fittings, let's assume that a conservative estimate is 30% of the pipe friction head loss, the fittings friction head loss is $= 0.3 \times 2.4 = 0.7$ feet. If there is a check valve on the suction line the friction loss of the check valve will have to be added to the friction loss of the pipe. A typical value of friction loss for a check valve is 5 feet. A jet pump does not require a check valve therefore I will assume there is no check valve on the suction of this system. The total friction loss for the suction side is then $2.4 + 0.7 = 3.1$ feet.

You can find the friction loss for a 1" pipe at 10 gpm in the Cameron Hydraulic data book of which the next figure is an extract:

Flow U S gal per min		Friction of Water New Steel Pipe (Continued) (Based on Darcy's Formula) 1 Inch								
		Standard wt steel—sch 40 1.049" inside dia			Extra strong steel—sch 80 .957" inside dia			Schedule 160 steel .815" inside dia		
		Velocity ft per sec	Velocity head ft	Head loss ft per 100 ft	Velocity ft per sec	Velocity head ft	Head loss ft per 100 ft	Velocity ft per sec	Velocity head ft	Head loss ft per 100 ft
2	0.74	.009	.385	.89	.01	.599	1.23	.023	1.26	
3	1.11	.019	.787	1.34	.03	1.19	1.85	.053	2.60	
4	1.48	.034	1.270	1.79	.05	1.99	2.46	.094	4.40	
5	1.86	.054	1.90	2.23	.08	2.99	3.08	.147	6.63	
6	2.23	.077	2.65	2.68	.11	4.17	3.69	.211	9.30	
8	2.97	.137	4.50	3.57	.20	7.11	4.92	.376	15.9	
10	3.71	.214	6.81	4.46	.31	10.8	6.15	.587	24.3	
12	4.45	.308	9.58	5.36	.45	15.2	7.38	.845	34.4	
14	5.20	.420	12.8	6.25	.61	20.4	8.61	1.15	46.2	
16	5.94	.548	16.5	7.14	.79	26.3	9.84	1.50	59.7	
18	6.68	.694	20.6	8.03	1.00	32.9	11.07	1.90	74.9	
20	7.42	.857	25.2	8.92	1.24	40.3	12.30	2.35	91.8	
22	8.17	1.036	30.3	9.82	1.50	48.4	13.53	2.84	110	
24	8.91	1.23	35.8	10.7	1.8	57.2	14.76	3.38	131	
26	9.65	1.45	41.7	11.6	2.1	66.8	15.99	3.97	153	
28	10.39	1.68	48.1	12.5	2.4	77.1				
30	11.1	1.93	55.0	13.4	2.8	88.2				
35	13.0	2.62	74.1	15.6	3.8	119				
40	14.8	3.43	96.1	17.9	5.0	154				
45	16.7	4.33	121	20.1	6.3	194				

Figure 43a Friction loss data from the Cameron Hydraulic data book (available at <http://www.cameronbook.com/Merchant2/Merchant.mv>).

Friction loss on the discharge side of the pump

According to calculation or the use of tables which is not presented here the friction loss for a 3/4" tube is has a friction loss of 0.23 feet per feet of pipe. In this case, the distances are 10 feet of run on the main distributor and another 20 feet off of the main distributor up to the bath, for a total length of 30 feet. The friction loss in feet is then $30 \times 0.23 = 6.9$ feet. There is some friction loss in the fittings, let's assume that a conservative estimate is 30% of the pipe friction head loss, the fittings friction head loss is $= 0.3 \times 6.9 = 2.1$ feet. The total friction loss for the discharge side is then $6.9 + 2.1 = 9$ feet.

You can find the friction loss for a 0.75" pipe at 10 gpm in the Cameron Hydraulic data book of which the next figure is an extract:

¾ Inch									
Flow U S gal per min	Standard wt steel—sch 40			Extra strong steel—sch 80			Steel—schedule 160		
	.824" inside dia			.742" inside dia			.612" inside dia		
	Velocity ft per sec	Velocity head ft	Head loss ft per 100 ft	Velocity ft per sec	Velocity head ft	Head loss ft per 100 ft	Velocity ft per sec	Velocity head ft	Head loss ft per 100 ft
1.5	0.90	.013	0.72	1.11	.02	1.19	1.64	.042	3.05
2.0	1.20	.023	1.19	1.48	.03	1.99	2.18	.074	5.12
2.5	1.50	.035	1.78	1.86	.05	2.97	2.73	.115	7.70
3.0	1.81	.051	2.47	2.23	.08	4.14	3.27	.166	10.8
3.5	2.11	.069	3.26	2.60	.11	5.48	3.82	.226	14.3
4.0	2.41	.090	4.16	2.97	.14	7.01	4.36	.295	18.4
4.5	2.71	.114	5.17	3.34	.17	8.72	4.91	.374	22.9
5.0	3.01	.141	6.28	3.71	.21	10.6	5.45	.462	28.0
6	3.61	.203	8.80	4.45	.31	14.9	6.54	.665	39.5
7	4.21	.276	11.7	5.20	.42	19.9	7.64	.905	53.0
8	4.81	.360	15.1	5.94	.55	25.6	8.73	1.18	68.4
9	5.42	.456	18.8	6.68	.69	32.1	9.82	1.50	85.8
10	6.02	.563	23.0	7.42	.86	39.2	10.91	1.85	105
11	6.62	.681	27.6	8.17	1.04	47.0	12.00	2.23	126
12	7.22	.722	32.5	8.91	1.23	55.5	13.09	2.66	149
13	7.82	.951	37.9	9.63	1.44	64.8	14.18	3.13	175
14	8.42	1.103	43.7	10.4	1.7	74.7	15.27	3.62	202
16	9.63	1.44	56.4	11.9	2.2	96.7	17.45	4.73	261
18	10.8	1.82	70.8	13.4	2.8	121			
20	12.0	2.25	86.8	14.8	3.4	149			

Note: No allowance has been made for age, difference in diameter, or any abnormal condition of interior surface. Any factor of safety must be estimated from the local conditions and the requirements of each particular installation. It is recommended that for most commercial design purposes a safety factor of 15 to 20% be added to the values in the tables—see page 3-5.

Figure 43b Friction loss data from the Cameron Hydraulic data book.

You can also do pipe friction calculation on the Fluide Design web site:
<http://www.fluidedesign.com/applets.htm>.

The total friction loss for piping in the system is then $9 + 3.1 = 12.1$ feet.

The static head as per Figure 41 is 35 feet. Therefore the total head is $35 + 12.1 = 47$ feet. We can now go to the store and purchase a pump with at least 47 feet of total head at 10 gpm. Sometimes total head is called Total Dynamic Head (T.D.H.), it has the same meaning. The pump's rating should be as close as possible to these two figures without splitting hairs. As a guideline, allow a variation of plus or minus 15% on total head. On the flow, you can also allow a variation but you may wind up paying for more than what you need.

What is the pump rating? The manufacturer will rate the pump at its optimum total head and flow, this point is also known as the best efficiency point or B.E.P. At that flow rate, the pump is at its most efficient and there will be minimal amount of vibration and noise. Of course, the pump can operate at other flow rates, higher or lower than the rating but the life of the pump will suffer if you operate too far away from its normal rating. As a guideline, aim for a variation of plus or minus 15% on total head.

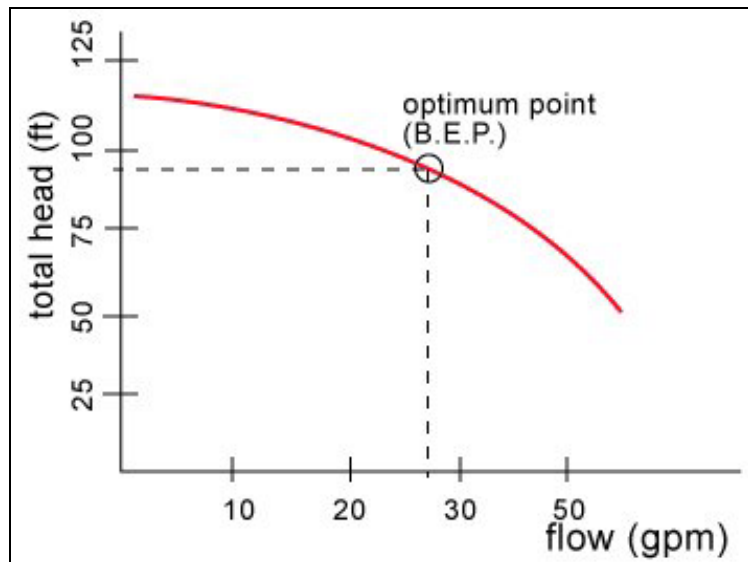

Figure 44 Best efficient point of a pump.

14. Examples of common residential water systems

This next figure shows a typical small residential water system. The red tank is an accumulator (see http://www.fluidedesign.com/pump_glossary.htm).



Figure 44a Typical small residential plumbing system.

The following figures show various common water systems and indicates what the static head, the friction head and the pump total head.

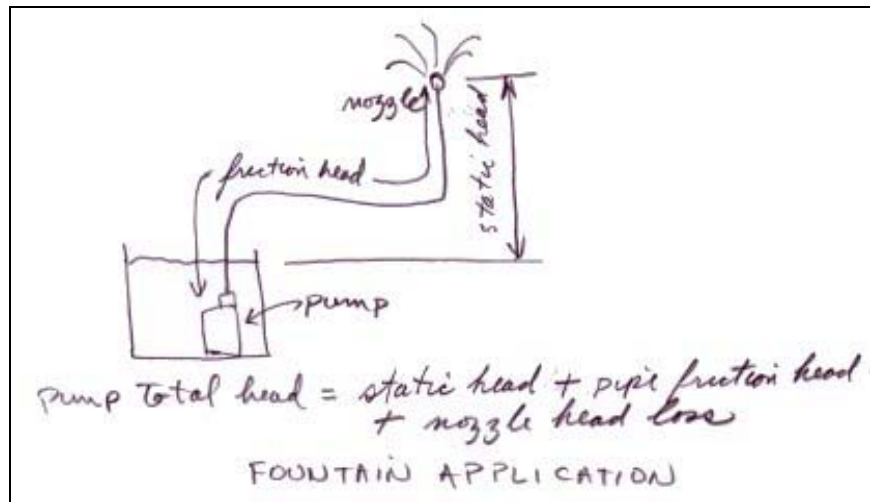

Figure 45 Fountain water supply with nozzle.

This web site (http://www.atlanticfountains.com/spray_patterns.htm) will tell you the flow requirement of each nozzle and the nozzle head requirement.

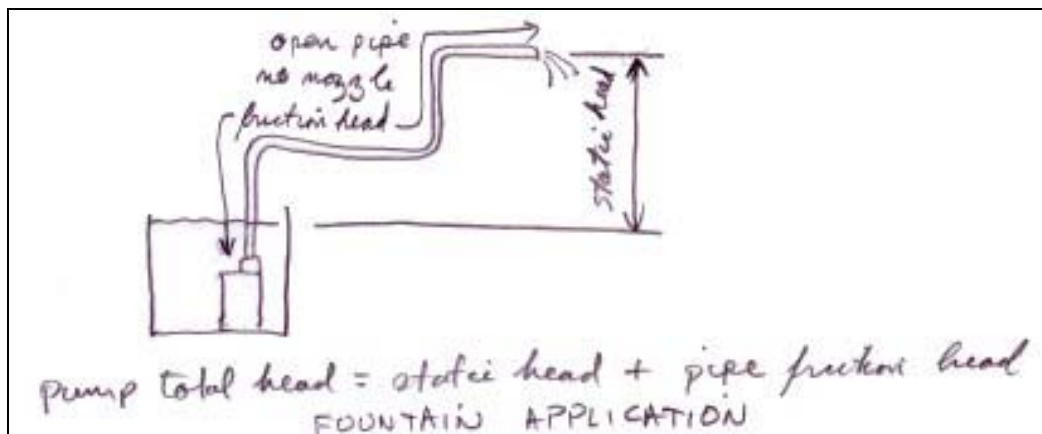

Figure 46 Fountain water supply (no nozzle).

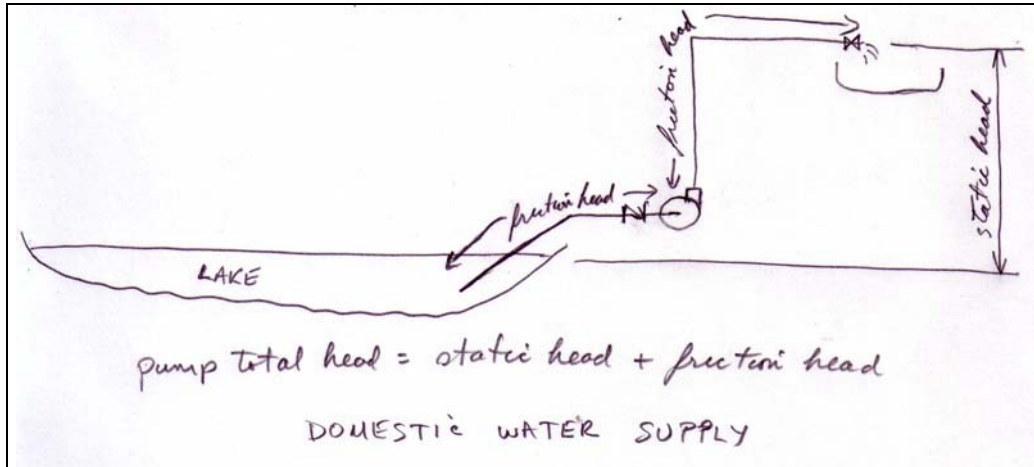

Figure 47 Domestic water supply.

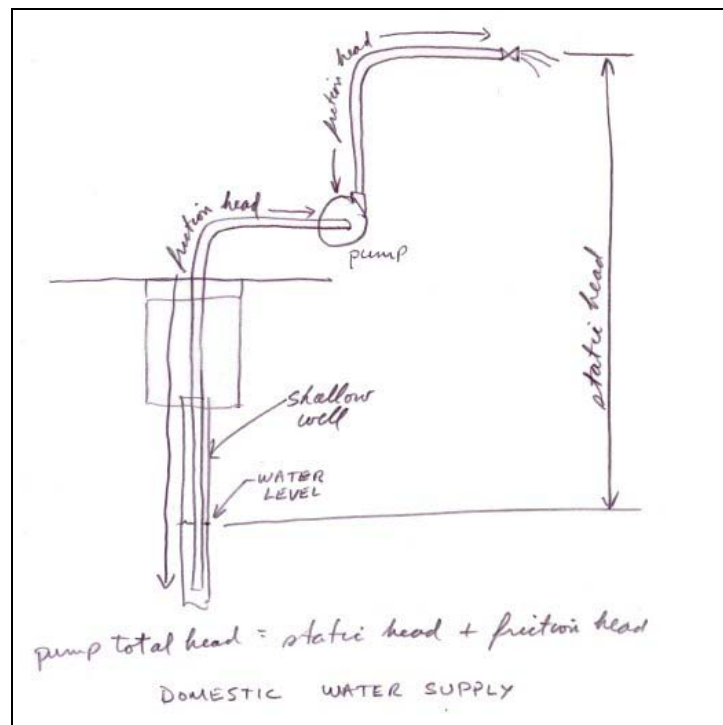

Figure 48 Domestic water supply (shallow well).

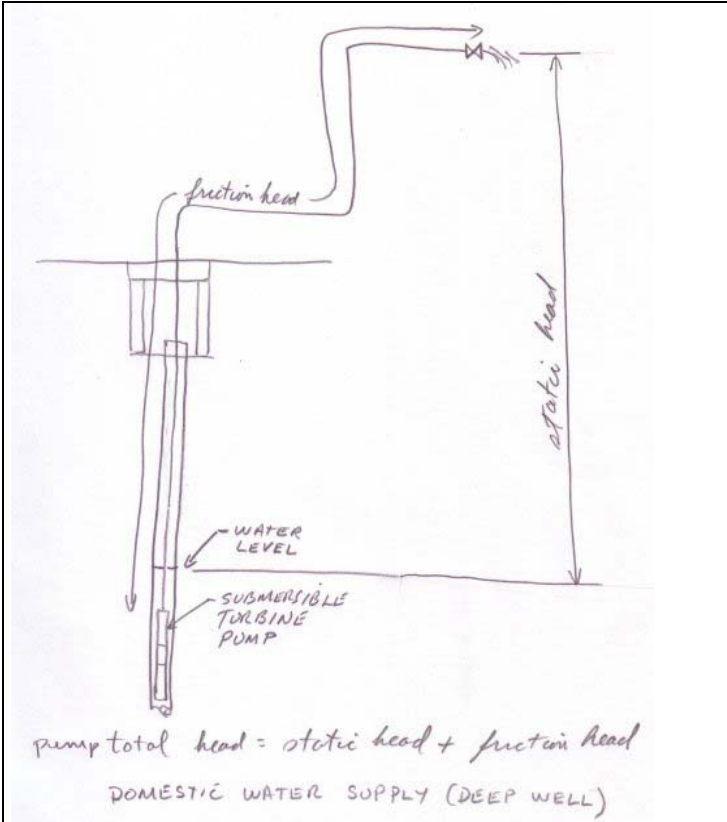

Figure 49 Domestic water supply (deep well).

15. Calculate the pump discharge pressure from the pump total head

To calculate the pressure at the bottom of a pool, you need to know the height of the water above you. It doesn't matter if it's a pool or a lake, the height is what determines how much fluid weight is above and therefore the pressure.

Pressure can be applied to a small object or a big object. For example if we take tanks of different sizes from small to big, the pressure will be the same everywhere at the bottom no matter how big the surface as long as the surface is at the same level.

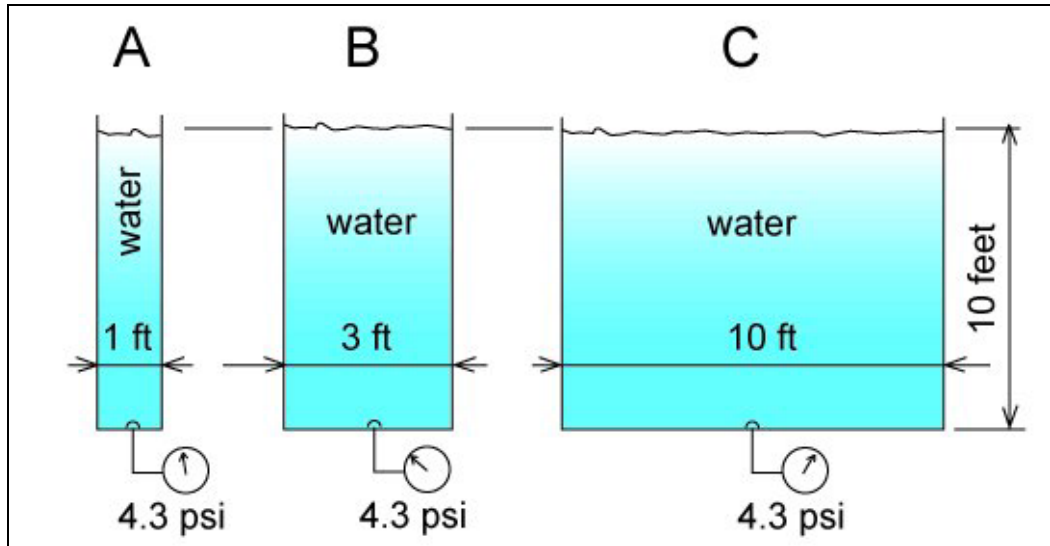

Figure 50 Pressure at the bottom of tanks of various sizes.

Pressure is equal to a force divided by a surface. It is often expressed in pounds per square inch or psi. The force is the weight of water. The density of water is 62.3 pounds per cubic foot.

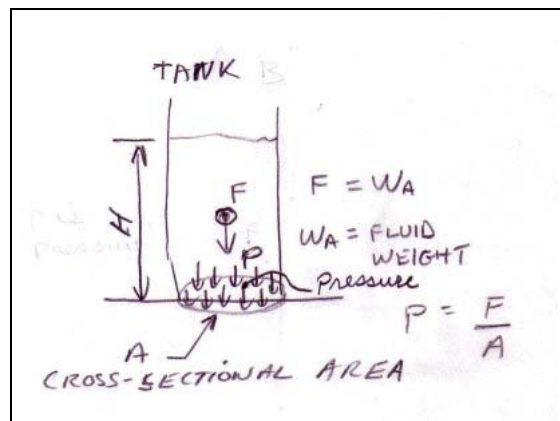

Figure 51 Pressure is the weight of the liquid divided by the cross-sectional area.

The weight of water in tank A is the density times it's volume.

$$W_A = \text{dens.} \times \text{volume}$$

The volume of the tank is the cross-sectional area A times the height H.

The cross-sectional area is pi or π times the diameter squared divided by 4.

$$A = \frac{\pi \times D^2}{4}$$

The cross-sectional area of tank A is:

$$A = \frac{3.1416 \times 1^2}{4} = 0.78 \text{ ft}^2$$

The volume V is A x H:

$$V = A \times H = 0.78 \times 10 = 7.8 \text{ ft}^3$$

The weight of the water W_A is:

$$W_A = \text{dens.} \times V = 62.3 \times 7.8 = 485.9 \text{ lb}$$

Therefore the pressure is:

$$p = \frac{W_A}{A} = \frac{485.9}{0.78} = 622.9 \text{ lb / ft}^2$$

This is the pressure in pounds per square feet, one more step is required to get the pressure in pounds per square inch or psi. There is 12 inches to a foot therefore there is $12 \times 12 = 144$ inches to a square foot.

The pressure p at the bottom of tank A in psi is:

$$p = p(\text{lb / ft}^2) \times \frac{1 \text{ ft}^2}{144 \text{ in}^2} = \frac{622.9}{144} = 4.3 \text{ lb / in}^2 = 4.3 \text{ psi}$$

If you do the calculation for tanks B and C you will find exactly the same result, the pressure at the bottom of all these tanks is 4.3 psi.

The general relationship for pressure vs. tank height is:

$$p(\text{psi}) = \frac{1}{2.31} SG \times H(\text{ft})$$

SG or specific gravity is another way of expressing density, it is the ratio of a fluid's density to that of water, so that water will have an SG =1. Denser liquids will have a value greater than 1 and lighter liquids a value less than 1. The usefulness of specific

gravity is that it has no units since it is a comparative measure of density or a ratio of densities therefore specific gravity will have the same value no matter what system of units we are using, Imperial or metric. For those of you who would like to see how this general relationship is found go to Appendix E at the end of this article.



We can measure head at the discharge side of the pump by connecting a tube and measuring the height of liquid in the tube. Since the tube is really only a narrow tank we can use the pressure vs. tank height equation

$$p(\text{psi}) = \frac{1}{2.31} SG \times H(\text{ft})$$

to determine the discharge pressure. Alternatively, if we put a pressure gauge at the pump discharge, we can then calculate the discharge head.

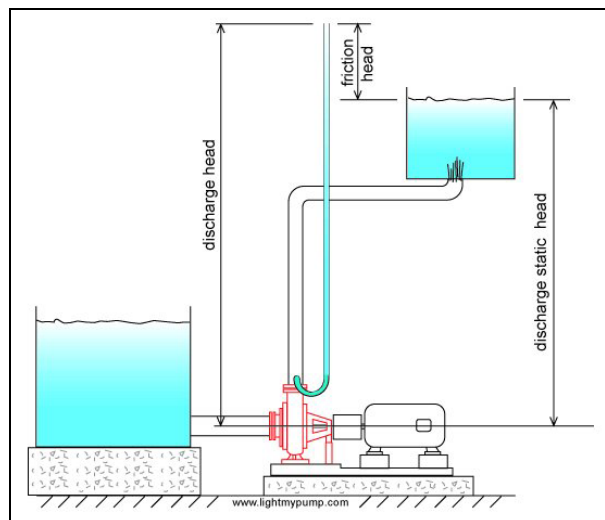

Figure 52 Discharge static head plus friction head equals pump discharge head.

We can calculate the discharge pressure of the pump based on the total head which we get from the characteristic curve of the pump. This calculation is useful if you want to troubleshoot your pump or verify if it is producing the amount of pressure energy that the manufacturer says it will at your operating flow rate.

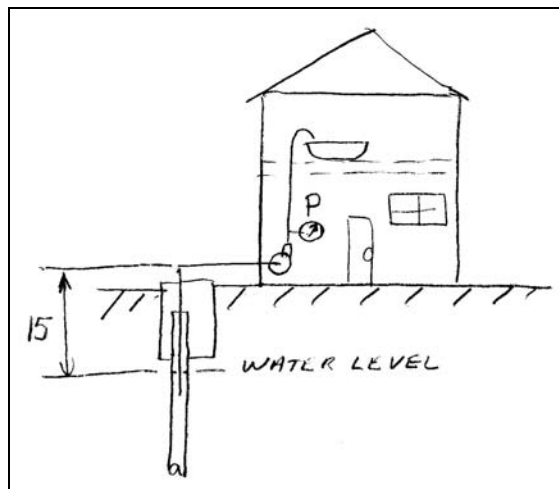

Figure 53 Typical pump system.

For example if the characteristic curve of the pump is as shown in Figure 55 and the flow in the system is 20 gpm. The total head is then 100 feet.

The installation is as shown in Figure 53, a domestic water system that takes its water from a shallow well 15 feet lower than the pump suction.

The pump will have to generate lift to get the water up to its suction connection. This means that the pressure will be less than the atmosphere pressure at the pump suction.

Why is this pressure less than atmospheric pressure or low? If you take a straw, fill it with water, cover one end with your fingertip and turn it upside down you will notice that the liquid does not come out of the straw, try it!. The liquid is pulled downward by gravity and creates a low pressure under your fingertip. The liquid is maintained in balance because the low pressure and the weight of the liquid is exactly balanced by the force of atmospheric pressure that is directed upwards.

The same phenomenon occurs in the pump suction which is pulling up liquid from a low source. Like in the straw, the pressure close to the pump suction connection must be low for the liquid to be supported.

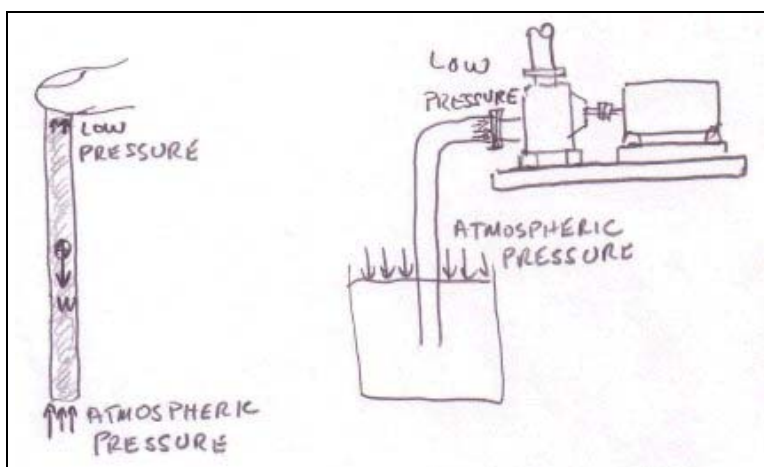

Figure 54 There is low pressure at the pump suction when the liquid surface is below the pump.

To calculate the discharge head, we determine the total head from the characteristic curve and subtract that value from the pressure head at the suction, this gives the pressure head at the discharge which we then convert to pressure.

We know that the pump must generate 15 feet of lift at the pump suction, lift is negative static head. It should in fact be slightly more than 15 feet because a higher suction lift will be required due to friction. But let's assume that the pipe is generously sized and that the friction loss is small.

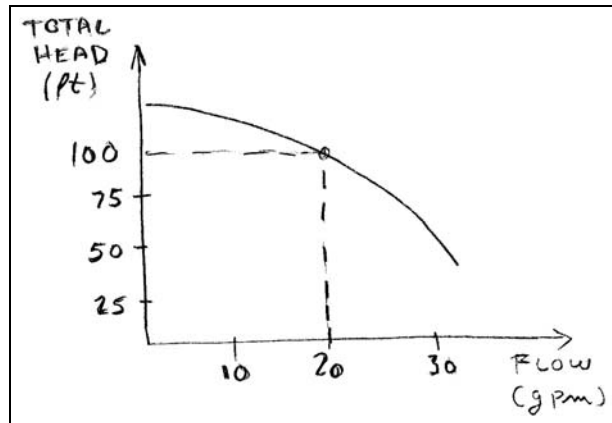

Figure 55 Characteristic pump curve.

$$\text{TOTAL HEAD} = 100 = H_D - H_S$$

or

$$H_D = 100 + H_S$$

The total head is equal to the difference between the pressure head at the discharge H_D and the pressure head at the suction H_S . H_S is equal to -15 feet because it is a lift therefore:

$$H_D = 100 + (-15) = 85 \text{ feet}$$

The discharge pressure will be:

$$p = \frac{1}{2.31} \times 1.0 \times 85 = 37 \text{ psig}$$

Now you can check your pump to see if the measured discharge pressure matches the prediction. If not, there may be something wrong with the pump.

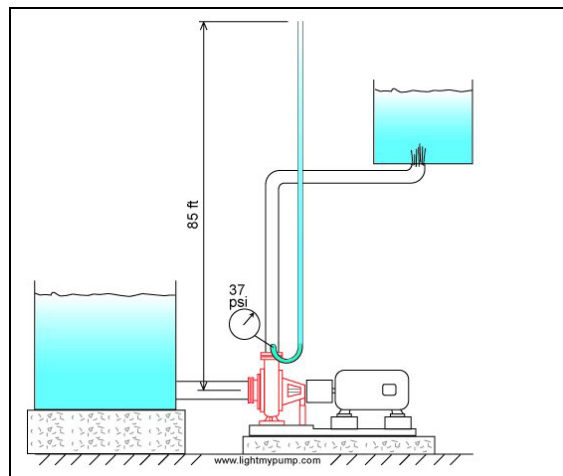

Figure 56 Head vs. pressure measurement.

Note: you must be careful where you locate the pressure gauge, if it is much higher than the pump suction, say higher than 2 feet, you will read less pressure than actually is there at the pump. Also the difference in velocity head of the pump discharge vs. the suction should be accounted for but this is typically small.

APPENDIX A

Flow rate and friction loss for different pipe sizes based on 5 ft/s velocity

Flow rate and friction loss for different pipe sizes based on 15 ft/s velocity

Flow rate and friction loss for different pipe sizes based on 4.5 m/s velocity

Flow rate and friction loss for different pipe sizes based on 1.5 m/s velocity

F L U I D E D E S I G N

FRICTION HEAD LOSS FOR VARIOUS FLOW RATES

**Flow rate and friction head loss
for tubing and pipe sizes (Imperial)
(based on 5 ft/s velocity)**

Nom. dia. (in)	Inside dia. (in)	Flow rate (gpm)	Friction head loss (feet of head per feet of pipe)
1/4	0.311	1.2	0.58
1/2	0.527	3.4	0.29
3/4	0.745	6.8	0.187
1	0.995	12.1	0.13
1 1/2	1.6	31	0.071
2	2.067	52	0.051
2 1/2	2.469	75	0.041
3	3.068	115	0.031
4	4.026	198	0.022
6	6.065	450	0.014
8	8.125	808	0.009
10	10.25	1286	0.007
12	12.25	1837	0.0058
14	13.5	2230	0.052

F L U I D E D E S I G N

FRICTION HEAD LOSS FOR VARIOUS FLOW RATES

Flow rate and friction head loss
for tubing and pipe sizes (Imperial)
(based on 15 ft/s velocity)

Nom. dia. (in)	Inside dia. (in)	Flow rate (gpm)	Friction head loss (feet of head per feet of pipe)
1/4	0.311	3.55	4.68
1/2	0.527	10.2	2.35
3/4	0.745	20.4	1.51
1	0.995	36.3	1.04
1 1/2	1.6	94	0.575
2	2.067	157	0.42
2 1/2	2.469	224	0.335
3	3.068	346	0.256
4	4.026	595	0.184
6	6.065	1351	0.111
8	8.125	2424	0.078
10	10.25	3858	0.059
12	12.25	5510	0.048
14	13.5	6692	0.042

F L U I D E D E S I G N

FRICTION HEAD LOSS FOR VARIOUS FLOW RATES

Flow rate and friction head loss for tubing and pipe sizes (metric) (based on 1.5 m/s velocity)			
Inside dia. (mm)	Flow rate (L/s)	Flow rate (m ³ /h) x 1000	Friction head loss (meter of head per meter of pipe)
15	1.1	3.98	0.24
20	1.97	7.1	0.17
25	3.1	11.1	0.13
32	5	18.1	0.09
40	7.87	28.3	0.07
50	12.3	44.2	0.052
65	20.8	74.8	0.038
80	31.5	113	0.029
100	49.2	177	0.022
125	76.8	276.7	0.017
150	110.7	398	0.014
200	196.8	708	0.0096
250	307	1107	0.0073
300	443	1594	0.0059

F L U I D E D E S I G N

PIPE FRICTION HEAD LOSS FOR VARIOUS FLOW RATES

Flow rate and friction head loss for tubing and pipe sizes (metric) (based on 3 m/s velocity)			
Inside dia. (mm)	Flow rate (L/s)	Flow rate (m ³ /h) x 1000	Friction head loss (meter of head per meter of pipe)
15	0.68	2.43	0.9
20	1.2	4.32	0.62
25	1.88	6.75	0.47
32	3.07	11.06	0.34
40	4.8	17.28	0.26
50	7.5	27.00	0.2
65	12.7	45.63	0.14
80	19.2	69.12	0.11
100	30	108.00	0.084
125	46.9	168.75	0.064
150	67.5	243.00	0.051
200	120	432.00	0.036
250	187	675.00	0.027
300	270	972.00	0.022



FRICION HEAD LOSS FOR VARIOUS FLOW RATES

Flow rate and friction head loss for tubing and pipe sizes (metric) (based on 4.5 m/s velocity)			
Inside dia. (mm)	Flow rate (L/s)	Flow rate (m ³ /h) x 1000	Friction head loss (meter of head per meter of pipe)
15	3.32	12	1.97
20	5.9	21.2	1.36
25	9.2	33.2	1.03
32	15.1	54.4	0.75
40	23.6	85	0.57
50	36.9	133	0.43
65	62.4	225	0.31
80	94.5	340	0.24
100	148	531	0.183
125	231	830	0.139
150	332	1196	0.112
200	590	2125	0.079
250	922	3321	0.06
300	1328	4782	0.048

APPENDIX B

Formulas and an example of how to do pipe friction calculations

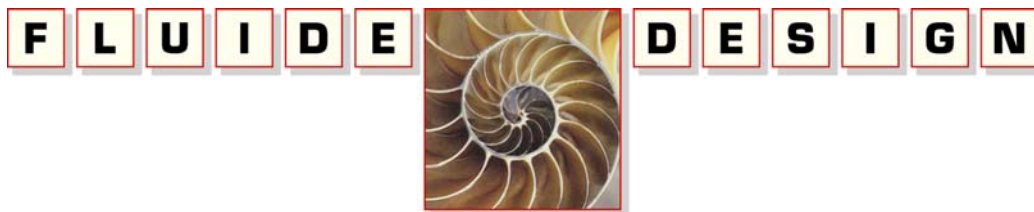

PIPE FRICTION CALCULATION

The average velocity v in a pipe is calculated based on the formula [1] and the appropriate units are indicated in parentheses. (see the last page for a table of all the symbols)

$$v(ft/s) = 0.4085 \frac{q(USgal./min)}{D^2(in)^2} \quad [1]$$

Or in the metric system

$$v(m/s) = 1273.23 \frac{q(L/s)}{D^2(mm)^2} \quad [1a]$$

The Reynolds R_e number is calculated based on formula [2].

$$R_e = 7745.8 \frac{v(ft/s)D(in)}{\nu(cSt)} \quad [2]$$

Or in the metric system

$$R_e = 1000 \frac{v(m/s)D(mm)}{\nu(cSt)} \quad [2a]$$

If the Reynolds number is below 2000 then the flow is said to be in a laminar regime. If the Reynolds number is above 4000 the regime is turbulent. The velocity is usually high enough in industrial processes and homeowner applications to make the flow regime turbulent. The viscosity of many fluids can be found in the Cameron Hydraulic data book. The viscosity of water at 60F is 1.13 cSt.

If the flow is laminar then the friction parameter f is calculated with the laminar flow equation [3].

$$f = \frac{64}{R_e} \quad [3]$$

If the flow is turbulent then the friction parameter f is calculated based on the Swamee-Jain equation [4].

$$f = \frac{0.25}{\left(\log_{10} \left(\frac{\varepsilon}{3.7 D} + \frac{5.74}{R_e^{0.9}} \right) \right)^2} \quad [4]$$

In the turbulent flow regime the friction factor f depends on the absolute roughness of the pipe inner wall. Table B1 provide some values for various materials.

PIPE MATERIAL	Absolute roughness ε (ft)
Steel or wrought iron	0.00015
Asphalt-dipped cast iron	0.0004
Galvanized iron	0.0005

Table B1

The friction factor $\Delta H_{FP}/L$ is calculated with the Darcy-Weisback equation [5]

$$\frac{\Delta H_{FP}}{L} \left(\frac{ft \ fluid}{100ft \ pipe} \right) = 1200 f \frac{(v(ft/s))^2}{D (in) \times 2g (ft/s^2)} \quad [5]$$

$$g=32.17 \text{ ft/s}^2$$

or in the metric system

$$\frac{\Delta H_{FP}}{L} \left(\frac{m \ fluid}{100 m \ pipe} \right) = 10^5 f \frac{(v(m/s))^2}{D (mm) \times 2g (m/s^2)} \quad [5a]$$

$$g=9.8 \text{ m/s}^2$$

The pipe friction loss ΔH_{FP} is calculated with equation [6]

$$\Delta H_{FP} (ft \ fluid) = \frac{\Delta H_{FP}}{L} \left(\frac{ft \ fluid}{100ft \ pipe} \right) \times \frac{L(ft \ pipe)}{100} \quad [6]$$

or in the metric system

$$\Delta H_{FP} (m \ fluid) = \frac{\Delta H_{FP}}{L} \left(\frac{fluid}{100m \ pipe} \right) \times \frac{L(m \ pipe)}{100} \quad [6a]$$

Example calculation

Calculate the pipe friction loss of a 2 1/2" schedule 40 (2.469" internal pipe diameter) new steel pipe with a flow rate of 149 gpm for water at 60F and a pipe length of 50 feet. The roughness is 0.00015 ft and the viscosity is 1.13 cSt.

The average velocity v in the pipe is:

$$v(ft/s) = 0.4085 \times \frac{149}{2.469^2} = 9.98 \quad [1']$$

The Reynolds Re number is:

$$R_e = 7745.8 \times \frac{9.98 \times 2.469}{1.13} = 1.69 \times 10^5 \quad [2']$$

The friction parameter f is:

$$f = \frac{0.25}{\left(\log_{10} \left(\frac{0.00015 \times 12}{3.7 \times 2.469} + \frac{5.74}{(1.69 \times 10^5)^{0.9}} \right) \right)^2} = 0.02031 \quad [4']$$

The friction factor $\Delta H_{FP}/L$ is calculated with the Darcy-Weisback equation [5]

$$\frac{\Delta H_{FP}}{L} \left(\frac{ft \ fluid}{100ft \ pipe} \right) = 1200 \times 0.02031 \times \frac{9.98^2}{2.469 \times 2 \times 32.17} = 15.34 \quad [5']$$

The pipe friction loss ΔH_{FP} is:

$$\Delta H_{FP} (ft \ fluid) = 15.34 \times \frac{50}{100} = 7.67 \quad [6']$$

Symbols

Variable nomenclature	Imperial system (FPS units)
D pipe diameter	in (inch)
Re Reynolds number	non dimensional
q flow rate	USgpm (gallons per minute)
ΔH_{FP} friction head loss in pipes	ft (feet)
ν viscosity	CSt (centistokes)
ε pipe roughness	Ft (feet)
v velocity	ft/s (feet/second)
L pipe length	ft (feet)
f friction parameter	Non dimensional
$\Delta H_{FP}/L$ friction factor	feet of fluid/100 ft of pipe
g acceleration due to gravity (32.17 ft/s ²)	ft/s ² (feet per second square)

APPENDIX C

Formulas and an example of how to do pipe fittings friction calculations

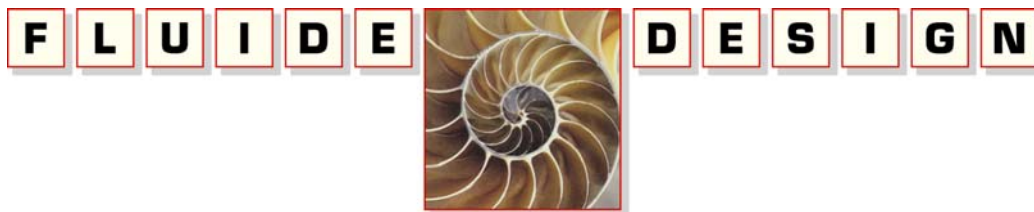

PIPE FITTING FRICTION CALCULATION

The friction loss for fittings depends on a K factor which can be found in many sources such as the Cameron Hydraulic data book or the Hydraulic Institute Engineering data book, the charts which I reproduce here are shown Figures C1 and C2.

The fittings friction ΔH_{FF} can be calculated based on the following formula where K is a factor dependant on the type of fitting, v is the velocity in feet/second, g is the acceleration due to gravity (32.17 ft/s² or 9.8 m/s²).

$$\Delta H_{FF}(\text{ft fluid}) = K \frac{v^2(\text{ft/s})^2}{2g(\text{ft/s}^2)}$$

In the metric system

$$\Delta H_{FF}(\text{m fluid}) = K \frac{v^2(\text{m/s})^2}{2g(\text{m/s}^2)}$$

For example a 2 1/2" inch screwed elbow has a K factor of 0.85 according to Figure C1 and using a velocity of 10 ft/s (this is determined from the flow rate). The fittings friction loss will be:

$$\Delta H_{FF}(\text{ft fluid}) = 0.85 \frac{10}{2 \times 32.17^2} = 1.3$$

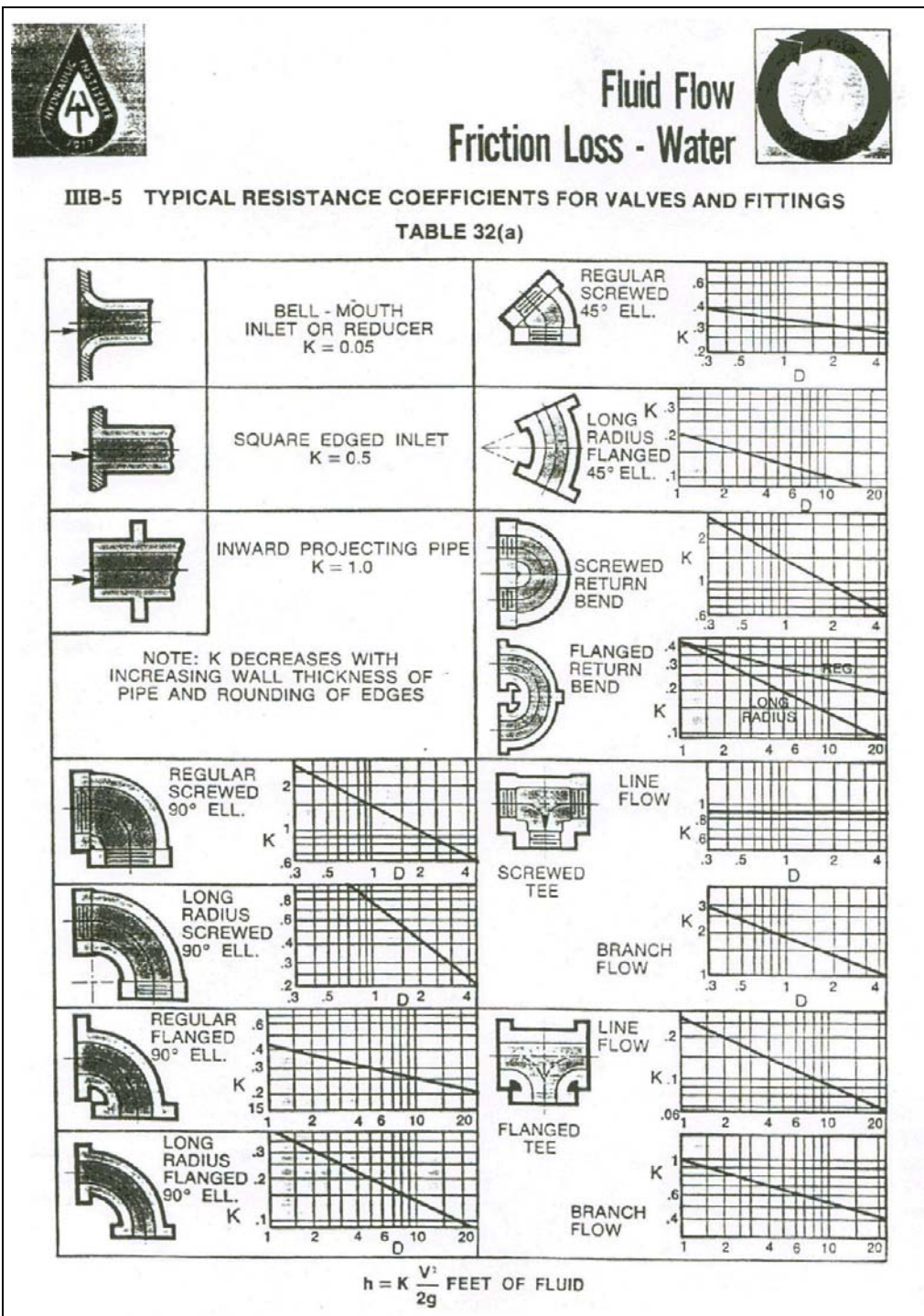

Figure C1 Pressure head loss K coefficients for fittings (source the Hydraulic Institute Standards book www.pumps.org).

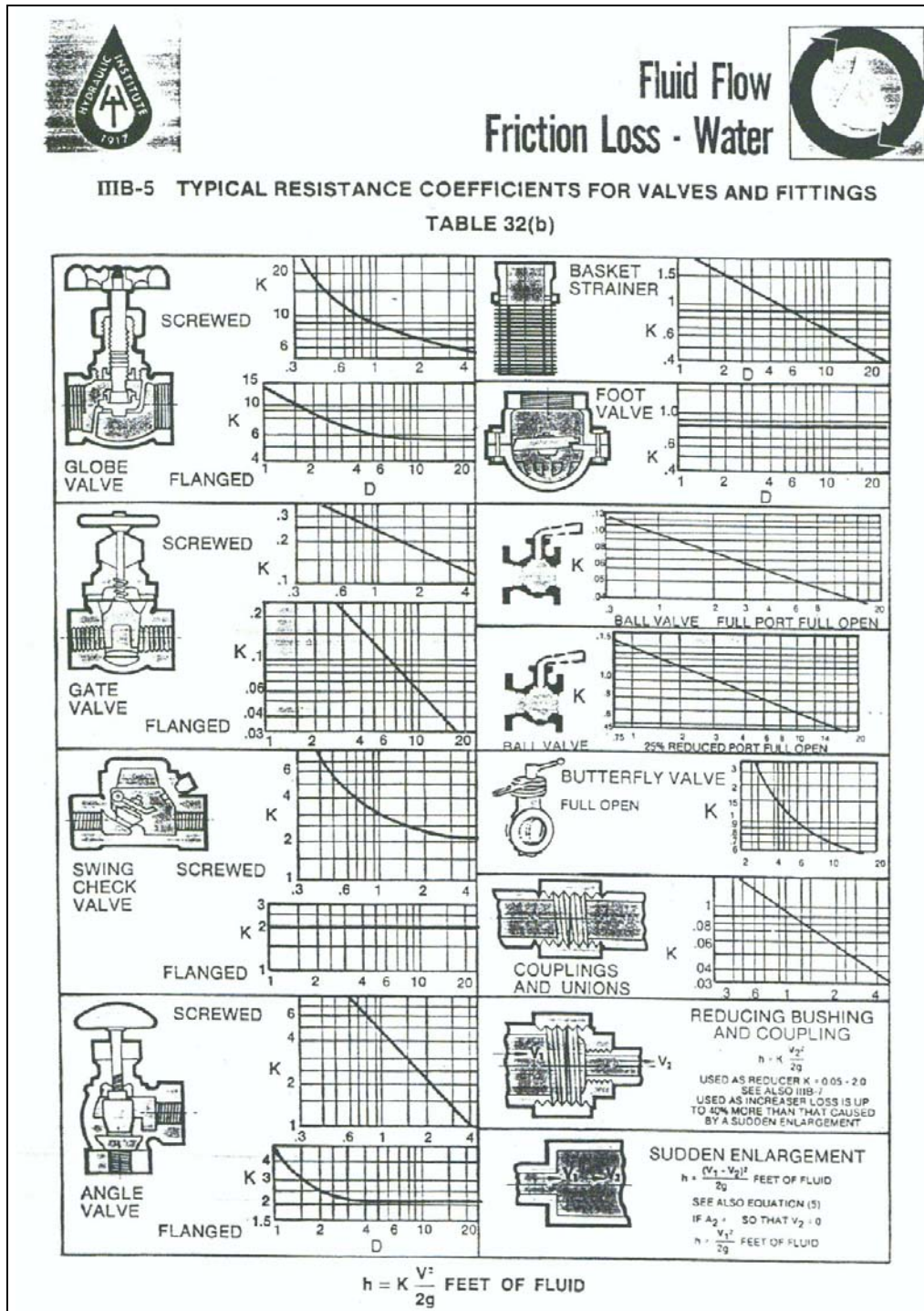

Figure C2 Pressure head loss K coefficients for manual valves and other devices (source the Hydraulic Institute Standards book www.pumps.org).

APPENDIX D

Formula and an example of how to do velocity calculation for fluid flow in a pipe



PIPE AVERAGE VELOCITY CALCULATION

The average velocity in a pipe can be calculated based on the following formula where v is the velocity in feet/second, D the internal diameter in inches and q the flow rate in USgallons per minute.

$$v(ft / s) = 0.4085 \frac{q(USgal . / min)}{D^2(in)^2}$$

In the metric system:

$$v(m / s) = 1273 .2 \frac{q(L / s)}{D^2(mm)^2}$$

For example a 2 ½" inch schedule 40 pipe has an internal diameter of 2.469 in, what is the average pipe velocity for a flow rate of 105 gpm.

$$v(ft / s) = 0.4085 \frac{105}{2.469^2} = 9.98$$

APPENDIX E

The relationship between pressure and pressure head

F L U I D E D E S I G N

THE RELATIONSHIP BETWEEN PRESSURE HEAD AND PRESSURE

We would like to be able to calculate at any time the head that corresponds to a certain pressure anywhere in the system. One place that's of particular interest is the pressure at the pump discharge. If we connect a tube to the pump discharge the pressure at the connection will make the liquid in the tube rise to a height that balances the force of pressure at the bottom. This will be the pressure head that corresponds to this pressure.

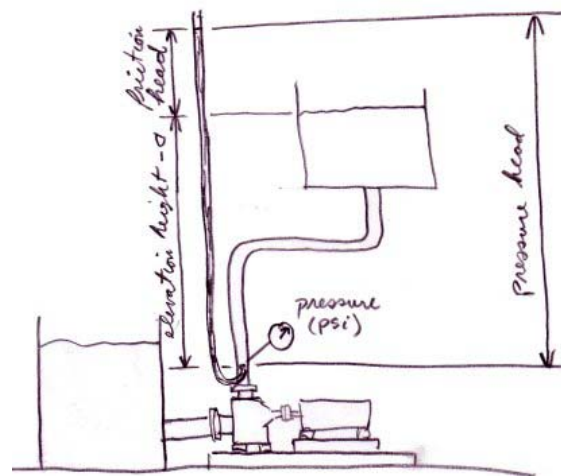

Figure E1

The measuring tube acts as a small narrow tank so that this is the same process as calculating the pressure at the bottom of a tank.

The weight of a fluid column of height (z) is:

$$F = \rho g V = \gamma V = \gamma z A \text{ since } V = z A$$

The pressure (p) is equal to the fluid weight (F) divided by the cross-sectional area (A) at the point where the pressure is calculated :

$$p = \frac{F}{A} = \frac{\gamma z A}{A} = \gamma z$$

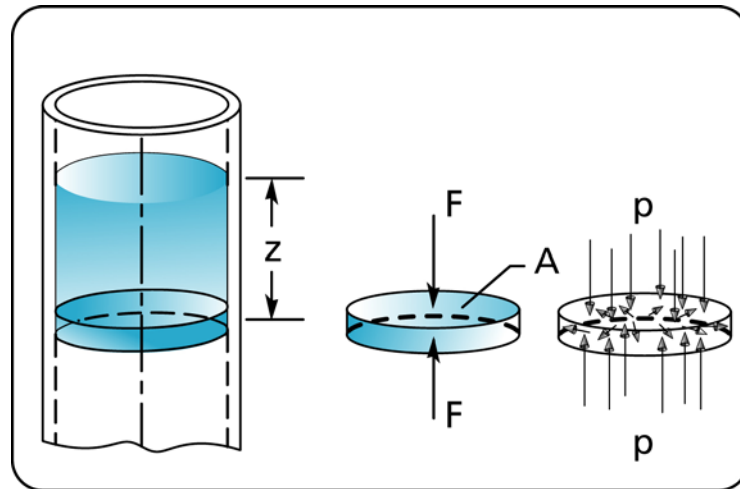

Figure E2 Pressure vs. hydrostatic head.

where F : force due to fluid weight

V : volume

g : acceleration due to gravity (32.17 ft/s^2)

ρ : fluid density in pound mass per unit volume

γ : fluid density in pound force per unit volume

The specific gravity of a fluid is:

$$S G = \frac{\rho_F}{\rho_W}$$

where ρ_F is the fluid density and ρ_W is water density at standard conditions.

Since

$$p = \gamma_F z = \frac{\rho_F g z}{g_c} \quad \text{and} \quad \rho_F = S G \rho_W \quad \text{therefore} \quad p = S G \frac{\rho_W g z}{g_c}$$

where γ_F is the fluid density in terms of weight per unit volume and ρ_F is the density in terms of mass per unit volume. The constant g_c is required to provide a relationship between mass in lbm and force in lbf).

The quantity $\rho_W g/g_c$ ($\rho_W = 62.34 \text{ lbm/ft}^3$ for water at 60°F) is:

$$\frac{\rho_W g}{g_c} = \frac{62.34(\text{lbm}/\text{ft}^3) \times 32.17(\text{ft}/\text{s}^2)}{32.17(\text{lbm}\text{-ft}/\text{lbf}\text{-s}^2)} \times \frac{1(\text{ft})}{144(\text{in}^2)} = \frac{1}{2.31} \left(\frac{\text{lbf}}{\text{in}^2\text{-ft}} \right)$$

After simplification, the relationship between the fluid column height and the pressure at the bottom of the column is:

$$p(\text{psi}) = \frac{1}{2.31} S G z(\text{ft of fluid})$$