

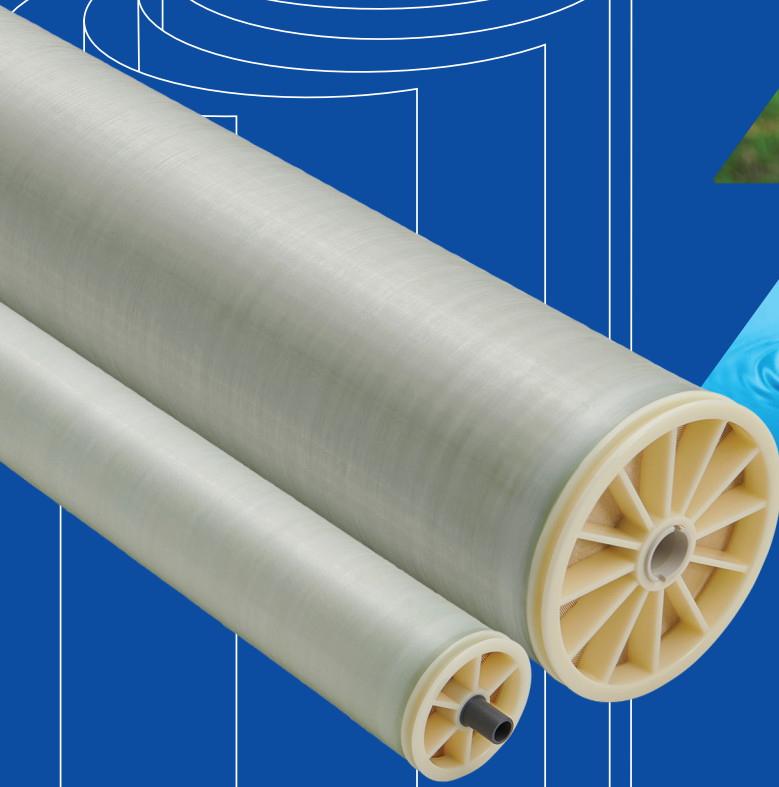

Toray RO Handling Manual

Last updated April 2021
06-G-MB1-210401



'TORAY'
Innovation by Chemistry

Notice

The data and information contained in this document are based upon rigorous technical testing by Toray, and is to the best of our knowledge reliable. Toray cannot control design and operating conditions, and consequently Toray does not assume any liability for results obtained or damage incurred through the application of the information provided herein. No liability, warranty or guarantee of final product performance by Toray is implied by the information provided in this document.

This manual supersedes all previous versions. Technical modification of products or production technology may necessitate changes to information in this manual without prior notice. Please verify that your version of the manual is the latest version available by either contacting Toray, or checking online at www.toraywater.com.

Terms and Conditions of Use

When using this document, please read the Terms and Conditions of Use below thoroughly and agree to them before using this document. By using this document, you agree to all of the Terms and Conditions of Use outlined here. The Terms and Conditions of Use are subject to change without prior notice, so please check with Toray for the latest Terms and Conditions of Use before using the document.

1. Intellectual Property Rights

The content in this document is protected by copyright laws in respective countries and relevant treaties. Accordingly, the document's information may not be reproduced, altered, or distributed without permission in writing from Toray. We permit downloading this document through Toray's website as a PDF file, stored on a personal computer, and printed out for customers' personal use. However, we prohibit transferring this document to any other websites or printed media. The material contained in this document may not be used without permission from the copyright holder for any other purpose that exceeds the scope permitted under copyright law.

2. Trademarks

The "TORAY" company name used in this document is a trade name, and the names of products manufactured by Toray are trademarks or registered trademarks. Toray's trade names and trademarks are protected under the Japanese Trademark Law, the Unfair Competition Prevention Law, and other legislation. The trade name and trademarks may not be used or reproduced without express permission from Toray.

3. Disclaimer

Toray takes all reasonable care in updating the information in this document. However, Toray makes no representation and warranty of any kind, either express or implied, including without limitation, any implied warranties concerning the accuracy, usefulness, suitability, or fitness for a particular purpose of the information in the document.

Toray shall not be responsible or liable for any losses or damage incurred due to the use of the information in this document. The information in this document is subject to change without prior notice, and Toray reserves the right to suspend or discontinue the publication of this document.

4. Availability of Goods and Services

The goods and services contained in this document are not available in all countries and regions. Goods and services may also be supplied under different trademarks in different countries. We ask that you contact your nearest Toray representative office if you wish to use the goods and services shown or implied in this document.

5. Proper Law and Court of Jurisdiction

This Terms and Conditions of Use shall be governed by and construed according to the laws of Japan. Any and all disputes arising out of or relating to this document shall be brought to the Tokyo District Court Tokyo, Japan.

Contact Information

Toray Industries, Inc. — RO Membrane Products Department Global Headquarters

Nihonbashi Mitsui Tower, 1-1, Nihonbashi-Muromachi 2 chome, Chuo-ku, Tokyo, 103-8666 Japan

Tel: +81-3-3245-4540 Fax: +81-3-3245-4913

Toray Membrane USA, Inc. (TMUS)

13435 Danielson Street, Poway, California 92064 USA

Tel: +1-858-218-2360 Fax: +1-858-218-2380

Toray Membrane Europe AG (TMEU)

Grabenackerstrasse 8b, Muenchenstein 1 CH-4142, Switzerland

Tel: +41-61-415-8710 Fax: +41-61-415-8720 E-mail: info.tmeu.mb@mail.toray

Toray Asia Pte. Ltd. (TAS)

111 Somerset Road, #14-01, Singapore 238164, Republic of Singapore

Tel: +65-6226-0525 Fax: +65-6226-0509

Toray BlueStar Membrane Co., Ltd. (TBMC)

Zone B, Tianzhu Airport Industrial Zone, Beijing 101318, China

Tel: +86-10-8048-5216 Fax: +86-10-8048-5217

Toray Membrane Middle East LLC (TMME)

PO Box 20279, Dammam 31952, Kingdom of Saudi Arabia

Tel: +966-13-568-0091 Fax: +966-13-568-0093

Toray Advanced Materials Korea Inc. (TAK)

Korea Toray R&D Center 7, Magokdong-ro 10-gil, Gangseo-gu, Seoul 07790, Republic of Korea

Tel: +82-22-3279-7389 Fax: +82-2-3279-7088

website: www.water.toray

TABLE OF CONTENTS

TMM-100	Introduction	6
TMM-200	Installation of RO Elements	7
	Before Installation	7
	Unpacking the Elements	8
	Installation of Spare Parts onto the Elements	12
	Insertion of Elements	13
	Documentation of the Loading Process	16
	Initial Start-up Checklist	16
TMM-210	Element Removal	17
TMM-220	Start-up Checklist for RO	18
	Pre-Commissioning Checklist	18
	Regular Start-up Checklist for Daily Operations	21
	Parameters for Start-up Procedures	22
	General Start-up Procedures for Different High-Pressure Pumps (HPP) Configurations	23
TMM-230	Operation Monitoring	26
	Monitoring	26
	Regular Monitoring and Check Points	26
	Logbook	26
	Normalization of System Performance	27
	Precautions and Useful Information for Monitoring Operating Data ...	28
	RO System Operation Parameters and Logging Intervals	29
	Normalization Program — TorayTrak	37
TMM-240	Shutdown Considerations for RO systems	41
	Short-term Shutdown	42
	Long-term Shutdown	42
TMM-250	Flushing Procedures	44
TMM-260	Preservation of RO Element Inside the Pressure Vessel	45
TMM-300	General Instructions and Conditions for RO Cleaning	47
TMM-310	Guidelines for RO cleaning	48
	When to Clean	48
	Determining Foulant Type	48
	Selecting the Right Cleaning Method	49
	Typical CIP Procedure	49
	Evaluating Cleaning effectiveness	49
TMM-320	Instructions for Chemical Cleaning	50
	General Guidelines	50
	Membrane Cleaning System Design Considerations	53
	Important Notes	54
TMM-330	Citric Acid Cleaning Procedure	55
	Flushing of elements	55
	Preparing a 2 wt% Citric Acid Solution	55

	Circulation of Cleaning Solution - - - - -	56
	Flush Elements - - - - -	56
	General Description of Citric Acid - - - - -	57
	General Description of Ammonia Solution - - - - -	57
TMM-340	DSS (Dodecyl Sodium Sulfate) Detergent Cleaning Procedure - - - - -	58
	Flushing of elements - - - - -	58
	Preparing a 0.03 wt% DSS Solution - - - - -	58
	Circulate Cleaning Solution - - - - -	58
	Flush Elements - - - - -	59
	General Description of DSS (Dodecyl Sodium Sulfate) - - - - -	59
	General Description of TSP (Trisodium Phosphate) - - - - -	60
	General Description of NaOH (Sodium Hydroxide) - - - - -	60
TMM-350	Acidic SHMP CIP Procedure - - - - -	61
	Flushing of Elements - - - - -	61
	Preparing a 1 wt% SHMP Solution - - - - -	61
	Circulate Cleaning Solution - - - - -	61
	Flush Elements - - - - -	62
	General Description of SHMP (Sodium Hexametaphosphate) - - - - -	63
TMM-360	Reverse Flow CIP / Flushing - - - - -	64
TMM-400	Sanitization Methods for RO/NF Elements - - - - -	65
	Sanitizing Solutions - - - - -	65
	Biocide - - - - -	66
TMM-410	Heat Sanitization of RO Elements (TS types) - - - - -	67
TMM-500	Storage - - - - -	68
	General Guidelines - - - - -	68
	Storage of New Elements - - - - -	68
	Storage of Used Elements - - - - -	69
TMM-600	Introduction to Troubleshooting - - - - -	70
	Permeate Center Pipe Probing Method - - - - -	70
TMM-610	Typical Performance Changes and Countermeasures - - - - -	73
	Case A: Normalized Permeate Flow Rate (NPFR) Decline: First Bank - - -	74
	Case B: Normalized Permeate Flow Rate (NPFR) Decline: Last Bank - - -	75
	Case C: Normalized Salt Passage (NSP) Increase: All Vessels - - - - -	76
	Case D: Normalized Permeate Flow Rate (NPFR) Decrease: All Banks Simultaneously - - - - -	77
	Case E: Normalized Permeate Flow Rate (NPFR) Decrease: All Banks Simultaneously with Variations for Individual Brine Stages - - -	78
	Case F: Differential Pressure (DP) Increase - - - - -	79
	Case G: Normalized Salt Passage (NSP) Increase: Individual Vessels - - - - -	80
TMM-700	Policy for Chemical Compatibility Test - - - - -	81

TMM-100 INTRODUCTION

TMM-100

Section page
1 of 1

General

Proper operation and maintenance of reverse osmosis (RO) system are key factors in maximizing long-term plant availability and efficiency and minimizing fault-related downtime.

This manual contains checklists and procedures for commissioning elements at start-up as well as providing useful information relating to regular operation and maintenance procedures. Separate sections cover data recording of membrane element performance and normalization.

Conventional Symbols



This symbol indicates either an imminent or potentially hazardous situation which will result in serious property damage, injury or death when the instruction is not observed.



This symbol indicates an important action or procedure which has to be taken without fail.



This symbol indicates a useful tip to handle Toray reverse osmosis membrane elements properly and effectively.

TMM-200

Section page
1 of 10

TMM-200 INSTALLATION OF RO ELEMENTS

Before Installation

1. Before feeding pre-treated into the elements, make sure the piping system and pressure vessels are free of dust, oil, metal residues, organic deposits, and other debris or contaminants. Repeat this procedure when elements are reloaded or replaced.
2. Verify that the feed water quality matches the system design values.
3. Flush the empty system with pre-treated RO feed water to completely remove all contaminants.
4. Remove end plates from both ends of pressure vessels, check inside of the vessel and if necessary clean mechanically.



INSTRUCTION. Clean the inside of the pressure vessels if it is dirty. Use a soft mop or swab, occasionally flushing the vessel with pre-treated water. Be careful not to scratch the inside surface of the pressure vessels.

5. Install the permeate adapter with o-rings into the permeate port of brine side end plate. Lubricate both parts using glycerin. Use the thrust ring according to the following note.

with “thrust ring”	without “thrust ring”
8-inch TM, TLF, TSW-series	others

Ensure that the thrust ring for the absorption of axial thrust (this is a part of the pressure vessel) is installed for the TM-series 8-inch elements to transmit axial forces from the brine side element (this is the first installed element).

6. Optionally and at this stage, insert the permeate adapter with o-rings into the permeate port of the brine side end plate. If this installation is carried out as the last step before re-fitting piping connections, the risk of seal damage can be minimized.
7. Attach the brine side end plate onto the brine side of the vessel and install the retaining ring set according to the pressure vessel's instruction manual.



USEFUL TIP. Remove the head seal before insertion to facilitate the final control of element installation. Verification of full element insertion is easier this way since the installed head seal usually provides additional resistance upon removing the endplate.



INSTRUCTION. Each element package shipped from Toray contains all necessary parts except the pressure vessel permeate adaptors. The pressure vessel manufacturer typically supplies the permeate adaptors and thrust devices. To ensure the pressure vessel manufacturer provides all of the correct parts, please specify the type of RO element that will be installed when ordering pressure vessels.

INSTALLATION OF RO ELEMENTS

TMM-200

Section page
2 of 10

Unpacking the Elements

Concerning the proper storage of RO elements before unpacking, please refer to section TMM-500: Storage of RO Element Outside of the Pressure Vessel. Toray recommends that new elements are stored in their original packaging until the products are ready to be loaded into the pressure vessels just before system start-up. Keeping the RO elements in its original packaging will help prevent any foreign debris from coming into contact with the RO element and affecting performance.

1. Open element boxes, and remove RO elements and accessories. The accessories are separately packaged in small plastic bags inside the element box. Handle the element with care to avoid damage. Place empty boxes aside.
2. Prepare the necessary parts, as shown in **Table TMM-200-1**.

Table TMM-200-1

Parts	Required Quantity
Brine seals	One per element
O-rings	4 pieces per element
Permeate port adaptor (open)*	One or two per pressure vessel
Permeate blind plug adaptor (solid)**	One per pressure vessel (optional)
Interconnectors	(qty. of elements) – (qty. of pressure vessels)

*The permeate port adaptor is not supplied by Toray. Please contact the engineering company to inquire about or obtain the part.

**End port pressure vessel requires a permeate blind plug adaptor.

3. If required, assemble interconnectors with supplied o-rings carefully to avoid any scratches. Use glycerine as a lubricant. Keep assembled interconnectors in a clean place until inserting into permeate tubes (**Figure TMM-200-1**).

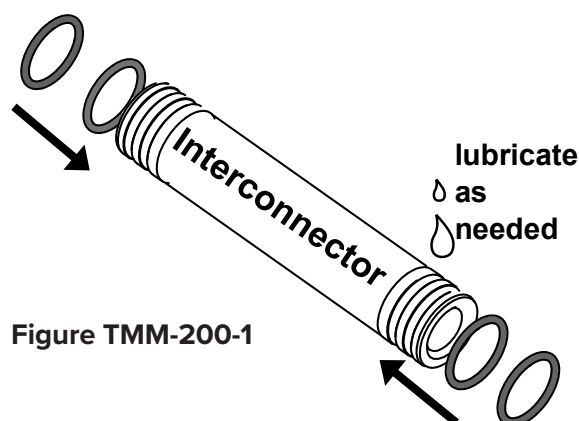

Figure TMM-200-1

TMM-200

Section page
3 of 10

INSTALLATION OF RO ELEMENTS

4. Safety considerations before opening the packing bags and removing the RO element:



DANGER. When shipped from Toray, new elements are packaged in approximately 0.5–1.0 wt% sodium bisulfite solution, or sodium chloride solution with an oxygen scavenger. Do not ingest these solutions, and handling them may irritate the eyes and skin. Personal protective equipment is required when handling. Please refer to the safety data sheet (SDS) for sodium bisulfite for additional handling instructions and information.

The element shell is FRP (Fiber Reinforced Plastic). Beware of glass fiber strands and use correct safety equipment.

5. Cut open the element's shipping bag and prepare for insertion, following illustrations provided below.



INSTRUCTION. Handle elements with care. Avoid dropping on hard surfaces. Use clean personal protective equipment (e.g., gloves, goggles) and avoid contamination of the element surfaces.



USEFUL TIP. Toray elements indicate a flow direction arrow on the element label to ensure that the brine seal is oriented correctly during installation. The arrow does not imply a mandatory installation direction – the element can be installed either way. The important point is correctly installing the brine seal relative to the direction of brine flow (see illustrations below).

Sample procedure A: removing the bag from an element packaged with polystyrene foam end-caps.

PPE Required!

Cut open the polybag at the top end.



Push the polybag down and leave the upper styrofoam cap in place for Step 3.

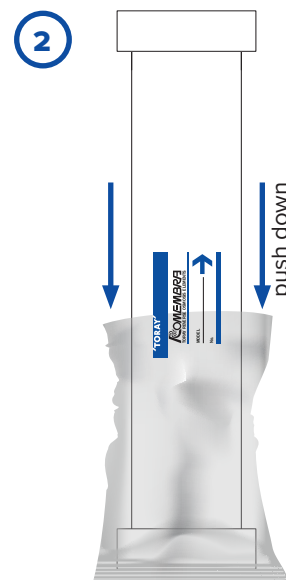

INSTALLATION OF RO ELEMENTS

TMM-200Section page
4 of 10

Flip the element onto the open end and stand it on the styrofoam cap.

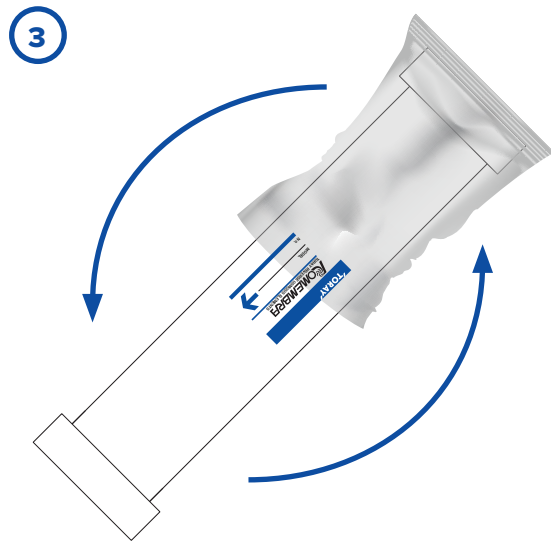

Remove the top foam cap together with the polybag.

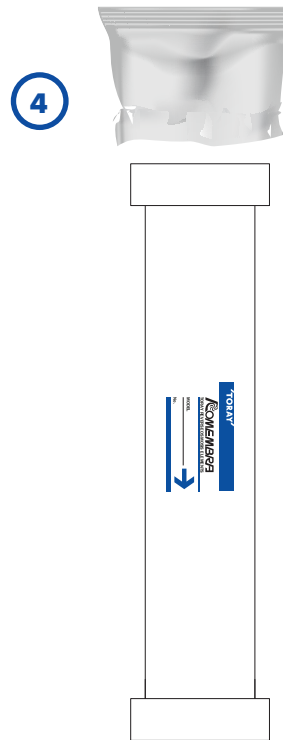

USEFUL TIP. The polybags are made of unique oxygen barrier materials for maintaining the lifetime of the oxygen scavenger packaged inside the bag. If the bags are carefully cut open at one end, they can be stored and reused later if any RO elements need to be conserved or shipped. It is also a good idea to retain some packaging boxes if an element needs to be stored.

INSTRUCTION. Handle the element with care when standing it on the floor to avoid breaking the oxygen scavenger sachet on the element's feed side. The best recommendation is to lay the element on a table and cut open the polybag.



TMM-200

Section page
5 of 10

INSTALLATION OF RO ELEMENTS

Sample procedure B: removing the bag from an element packaged without polystyrene foam end-caps.

Push the outer polybag down and remove the element still inside the inner polybag.

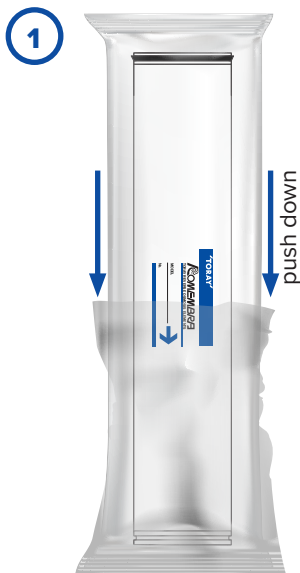

Cut open the inner polybag at the top end.



Push the inner polybag down.

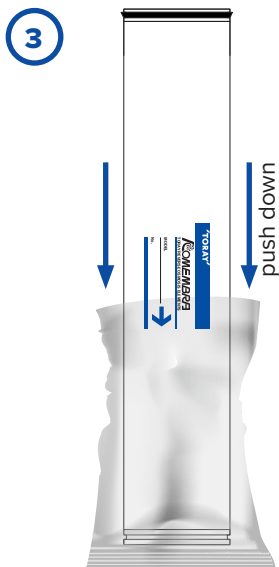

Remove the element from the inner polybag.

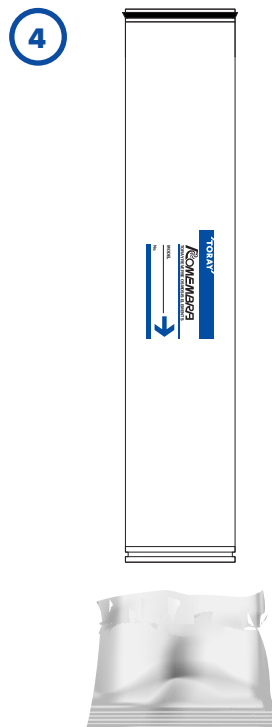

INSTALLATION OF RO ELEMENTS

TMM-200Section page
6 of 10

Installation of Spare Parts onto the Element

1. Brine seal: Toray elements shipped from Toray Membrane USA (TMUS) and Toray Membrane Middle East (TMME) comes with the brine seal pre-installed. Customers who received elements from TMUS or TMME can skip this step and only check the correct position of the seal. For other regions, follow the instructions illustrated in **Figures TMM-200-2** and **TMM-200-3**.

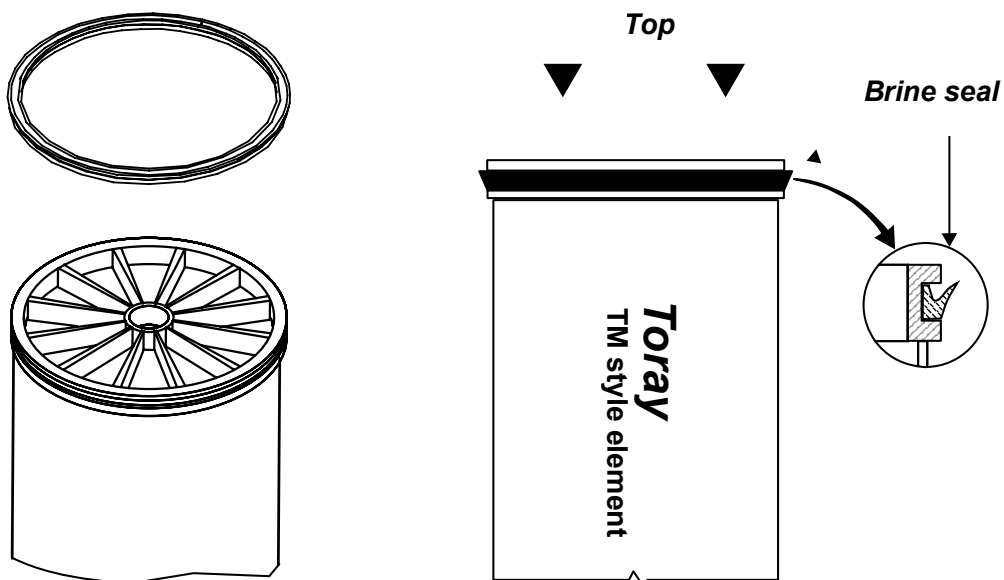
**Figure TMM-200-2**

2. Install the interconnector. Lubricate using glycerine as needed..

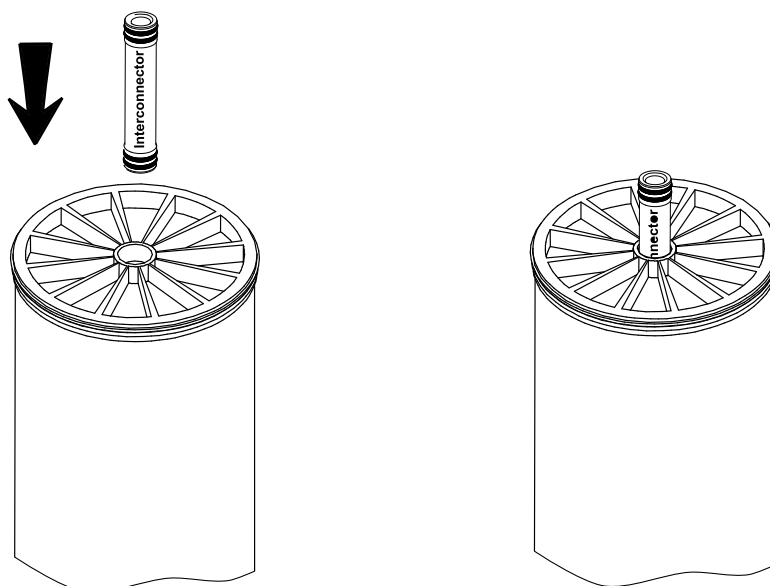
**Figure TMM-200-3**

TMM-200

Section page
7 of 10

INSTALLATION OF RO ELEMENTS

Insertion of Elements



INSTRUCTION. Work with a team of more than two people.

Verify the position and direction of the v-shaped brine seal, as shown in **Figure TMM-200-4**.

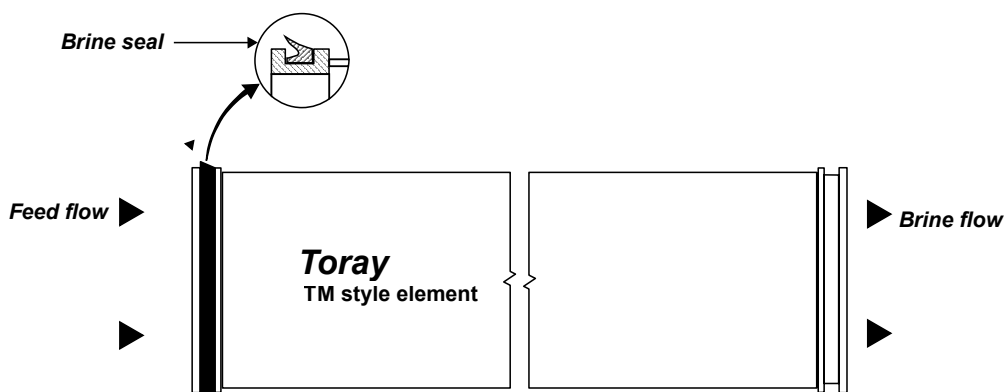

Figure TMM-200-4: Orientation of brine seal



CAUTION. Only one brine seal per element is required. **DO NOT INSTALL TWO.** The brine seal is typically fitted at the feed end of the element.

If not already done, open the feed side of the RO pressure vessel.

Prepare by removing any head locking devices before unpacking the elements (if site conditions allow this).

Lubricate the inside of the RO pressure vessel with water and glycerine to facilitate the installation process (especially with longer pressure vessels containing multiple elements). Consider using approximately 100 mL of glycerine for each pressure vessel. If the glycerine's viscosity is too high, dilute it with clean water as needed to improve lubrication.

Minimize the ingress of foreign matter, dust, and dirt to the pressure vessels by only opening and closing one vessel at a time.

Use a clean, soft mop, swab, or similar tool to lubricate the pressure vessel's full length, as shown in Figure TMM-200-5. Take precautions not to scratch the inner surface of the pressure vessel.

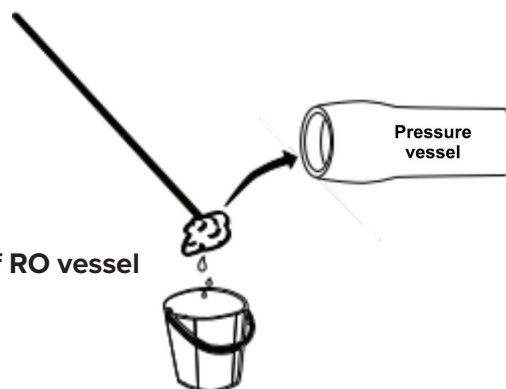

Figure TMM-200-5: Lubrication of RO vessel

INSTALLATION OF RO ELEMENTS

After lubricating the brine seals and pressure vessel's inner surface with glycerine, insert the element from the feed side into the pressure vessel. Approximately two-thirds of its length should be in the vessel, and one-third outside the vessel (**see Figure TMM-200-6**). Carefully insert the element, especially the first element.

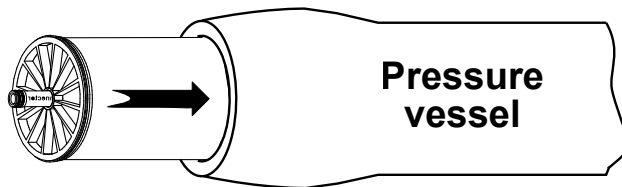

Figure TMM-200-6: Insertion of first element

CAUTION. Carefully handle the element to avoid jamming fingers between the vessel's edge and the element and preventing an injury.



Attach brine seal to the second element as same for the first element. Connect the two elements through the inter-connector (**see Figure TMM-200-7**). The partly inserted element should be held in place by a second person. Carefully push both elements firmly into the pressure vessel, keeping them in line to avoid damages to the inter-connector or brine seal.

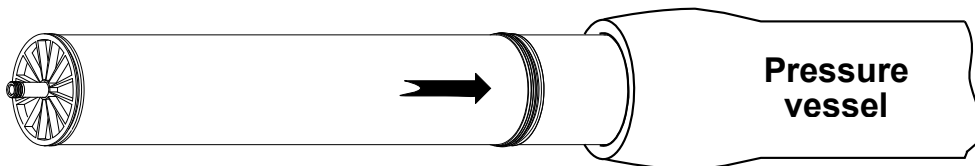

Figure TMM-200-7: Insertion of subsequent elements

Repeat the above steps and insert elements one by one into the pressure vessel. Insert the last element until only one-third of the element is outside the vessel. Locate and install correct brine end permeate adaptor (with o-rings) into the brine side end plate's internal permeate port.

Note: If permeate is collected from the brine end of the pressure vessel, install the permeate port adaptor. If permeate is not collected at the brine end, install the solid permeate plug adaptor.

Lubricate all o-rings with glycerine. Note: this step can wait until before installing the end plate into the pressure vessel to minimize any risk of o-ring damage.

Locate and install thrust ring into the brine side end of the pressure vessel (if provided).

INSTRUCTION. A Thrust Ring is typically necessary for 8-inch and larger diameter elements. Its purpose is to help absorb axial loads transmitted through the elements in the vessel during operation. Ensure it is installed, and omitting the thrust ring may result in mechanical damage to downstream elements.



TMM-200Section page
9 of 10**INSTALLATION OF RO ELEMENTS**

Insert brine side end cap into the brine side of the pressure vessel and install retaining ring set according to the pressure vessel manufacturer's instructions.

USEFUL TIP. Check for the complete insertion of the adaptor into the downstream element and correct positioning of the brine side end plate relative to the retaining ring groove by first removing the end plate seal (located on the circumference of the end plate). This reduces the resistance to movement of the end plate. The end plate seal **MUST** be replaced prior to final installation of the end plate.

Push the last element until the downstream element's permeate adaptor tube is firmly connected, and the brine side end plate is securely located against the retaining ring set.

The elements cannot be allowed to move in the axial direction to prevent premature wearing of the permeate seal rings. The pressure vessel manufacturer typically supplies the permeate ports. Shim rings are also generally available from the pressure vessel manufacturer to fill remaining gaps or tolerances (**see Figure TMM-200-8**).

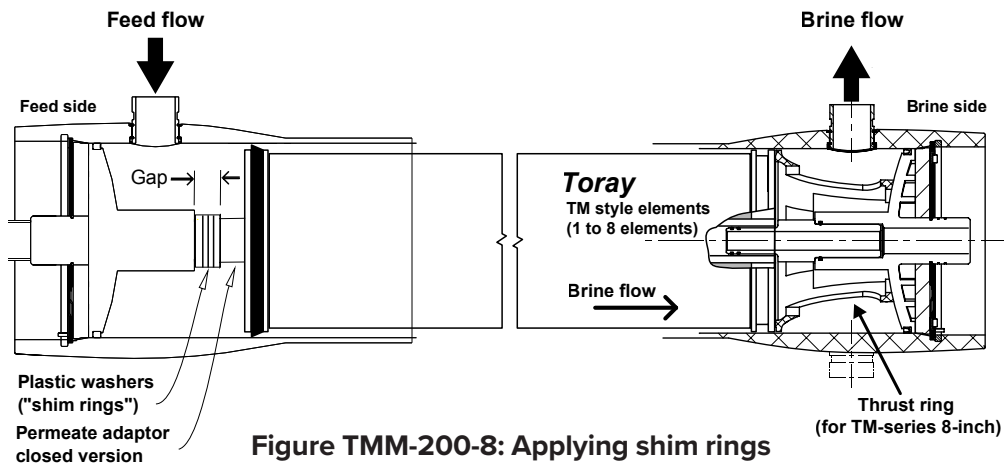
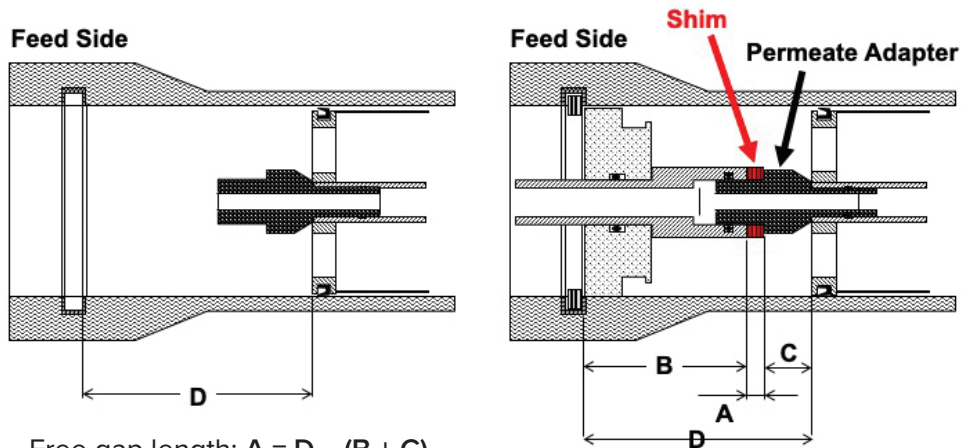

Figure TMM-200-8: Applying shim rings

After installing all membranes, check distance "A" (**see Figure TMM-200-9**). If distance "A" is larger than the thickness of the shim provided by the pressure vessel manufacturer, use the shim to fill the excess distance. The remaining space should be smaller than the thickness of the shim. Shims must be positioned on the upstream end of the vessel.

The risk of mechanical disconnection of permeate adapters is high if the permeate header is connected to the pressure vessel's feed side. Installing the permeate output connection to the pipework on the pressure vessel's brine side is recommended over the feed side.

INSTALLATION OF RO ELEMENTS



- Free gap length: $A = D - (B + C)$
- Requested number of shims ($t =$ shim thickness): $N = (A - 1 \text{ mm}) / t$

Figure TMM-200-9:
Shimming procedure

Permeate ports not used are best plugged with "closed" or "solid" type permeate adaptors (permeate plugs) supplied by the pressure vessel manufacturer. Plugging provides the best protection against the brine entering the permeate stream.

Attach the feed side end plate of the pressure vessel, and fit the piping system to end plates. **IMPORTANT:** Make sure to install head seals for all pressure vessel end plates at this time.

Documentation of the Loading Process

Toray membrane elements bear unique serial numbers, which can trace element origin and factory test results. Toray recommends recording the serial numbers of RO elements during the loading process, indicating their exact installed location. A successful way to do so is to create a "membrane map" or "loading diagram" similar to the sample below. Identification of the pressure vessel and elements are essential for performance monitoring and troubleshooting.

Pressure vessel no. (or row/column position)	Brine	Element # 123456	Other element #'s	Element # 123456	Feed

Pressure vessel no. (or row/column position)	Brine	Element # 123456	Other element #'s	Element # 123456	Feed

Use spreadsheet software such as Microsoft Excel to efficiently and effectively accomplish this task.

Initial Checklist for Start-up

After connecting all piping works, go through the checklist for initial start-up, as described in section **TMM-220: Start-up Checks for RO**.

TMM-210Section page
1 of 1**TMM-210 ELEMENT REMOVAL**

Due to inspection, long-term storage, shipment, or replacement purposes, elements may have to be removed from the pressure vessels.

The procedure to remove elements is as follows:



CAUTION. Before removing the connection from the feed, brine, and permeate piping ports on the pressure vessel, drain the water remaining in the pressure vessel to release the inside pressure.

1. Remove connection fittings from the feed, brine, and permeate piping ports on the pressure vessel.



USEFUL TIP. For side port and multipoint pressure vessel configurations, removing the permeate piping connections from the end plates is only required.

2. Remove the pressure vessel end plates from both the feed and concentrate ends of the pressure vessel.
3. Push the element stack into the vessel from the feed end of the pressure vessel. Push the element stack forward, so the brine end element sticks out of the pressure vessel far enough for the operator to grip the element and pull the remaining element out of the pressure vessel.
4. When removing the downstream element from the pressure vessel's brine end, pull the element straight out. Do not apply any load up, down, or side to side on the interconnector that connects the element being removed to the upstream element(s) remaining in the pressure vessel. Excessive load can damage the interconnector, product tube, brine seal, or interconnector o-rings.
5. Repeat steps 3 and 4 to remove the remaining element(s) in the pressure vessel. A section of the PVC pipe can push the elements forward towards the vessel's brine end for removal.
6. Remove and retain all interconnectors and permeate end plate adapters as these parts may be reused. It is good engineering practice to replace all o-ring seals and brine seals with new ones before replacement.

If you expect to re-install the elements soon, we recommend the elements are immediately repackaged into clean plastic bags (**see TMM-500: Storage**).

For reloading of RO elements, follow steps outlined in **TMM-200: Installation of RO Elements**.

For proper disposal of removed elements as industrial waste, please check local regulations and discard accordingly.

TMM-220 START-UP CHECKLIST FOR RO

TMM-220

Section page
1 of 8

Pre-commissioning Checklist

1. Before loading membrane elements and allowing water to enter the RO system, check the following:
 - Feed water quality matches design values for selected RO elements.
 - Verify that the pipework installation is free of all debris such as dust, grease, oil, metal residues.
 - Ensure the system's cleanliness and, if necessary, clean according to **TMM-200: Installation of RO Elements**.
 - Fouling Index (SDI15)
 - Turbidity (NTU)
 - Chlorine and any other oxidants are absent from the RO feed.
 - Sufficient bisulfite surplus can be dosed (if used for chlorine removal).
 - Verify that all instruments and components are operating correctly.

CAUTION. If chlorine dioxide is used for raw water sanitation, a combination of bisulfite dosing and activated carbon is strongly recommended for the total removal of oxidants. Experience has shown that bisulfite dosing alone is insufficient for raw water sanitation.



- Pretreatment is working correctly. Ensure the dosing of any flocculants used in the pretreatment (particularly cationic compounds and some nonionic compounds) are optimized, so such compounds are not present in the RO feed water.

CAUTION. Filter Cartridges must be free of surfactants, lubricants, and textile aides. Either ensure the filters are supplied without such additives or, if unsure if they are present, flush the cartridges according to cartridge manufacturer's published guidelines.



Install RO elements (**refer to Section TMM-200: Installation of RO Elements**). Ensure all fittings are tight (particularly Victaulic® couplings and pressure vessel end plate retaining rings).

CAUTION. Seal the pressure vessels as soon as possible, or a maximum of 12 hours after element installation. Conduct air purging and initial trial run without undue delay after confirming that fittings are tight and establishing mechanical safety. Avoid storage in stagnant water. Installed elements may remain in closed pressure vessels without contact with any water for up to four days. The product warranty does not cover performance changes resulting from the drying up of membrane products.



TMM-220Section page
2 of 8**START-UP CHECKLIST FOR RO**

2. Following element installation, purge air from the piping system, including all headers and RO vessels, for a minimum of one hour. Use pre-treated feed water at low feed pressure, with the brine valve fully opened. Pay attention not to exceed allowed ranges for flow and differential pressure!

A mixture of air and water present in the piping may lead to water hammering. We recommend venting the piping to the atmosphere to purge any entrained air while filling the piping. Keep the initial flow rate low to avoid unsafe conditions.

Once brine flow discharges from the brine piping, increase the flushing flow rate to expel any remaining air present in the piping through the vent ports.

Some pockets of air can be challenging to remove. We recommend starting and stopping the flush procedure several times to help move any remaining air pockets to the venting port(s). Continuous flushing may only pressurize the air while allowing it to remain trapped in the piping.

Suggested flush flow rates when venting air from piping depend on the pressure vessel diameter.

- For 8-inch vessels, regulate the flush flow rate to 40 L/min (11.0 gpm) per each vessel in parallel.
- For 4-inch vessels, regulate the flush flow rate to 10 L/min (3.0 gpm) per each vessel in parallel.

While flushing to remove air in the piping, keep the line pressure < 0.1 MPa (15 psi).

It is essential to open any permeate side isolating valves and minimize permeate side back pressure during the flushing procedure. Brine pressure should always be higher than permeate side pressure to avoid permeate back pressure problems.

For detailed instructions for flushing, **see TMM-250: Flushing Procedure.**

Pressure drop (feed to brine) across a pressure vessel / a single RO element must never exceed the following values:

Element types TM	Per vessel	Per single element
8-inch and 4-inch	0.34 MPa (50 psi)	0.10 MPa (15 psi)

START-UP CHECKLIST FOR RO

3. After bleeding all air from the system, the initial trial run for the RO can commence according to design operating parameters.

In particular, adjust the **Permeate flow rate** and **Recovery ratio** parameters to design values. Also, check the **Operating pressure**.

If the operating pressure is much higher than expected, conduct troubleshooting exercises to determine the cause, such as:

- a) If an energy recovery device (ERD) or booster pump is in use, is it operating correctly?
- b) If the design includes permeate throttling valves, are they set correctly?
- c) Verify the calibration of the instrumentation. Check conductivity mass balances for flow and recovery.
- d) Check individual stage differential pressures. Operation at differential pressures above the maximum pressure drop per vessel (listed on product specification sheets) may result in irreversible damage to the RO elements.
- e) Feed pressure always must be lower than the “maximum operating pressure” stated in the product specification sheet. If operating pressure exceeds the limit, the RO element may incur irreversible damage. The maximum operating pressure would vary depending on feed temperature. Please get in touch with a Toray membrane expert if you require detailed information.

For the first 1 hour of the trial run, discard the permeate and brine to drain. If the system is designed for recirculation, do not operate any internal concentrate recirculate during the first hour of the trial run.

The initial trial run is defined as the first exposure of the RO elements to the feed water, followed by an operation in design conditions, which should continue for 24 hours. Toray recommends 48 hours to confirm the initial performance of RO elements and salt passage stabilization.

4. Check the quality of permeate and system performance as follows:

After the initial 1 hour of operation, check the permeate conductivity for each vessel. If the permeate's conductivity is much higher than expected, check o-rings, brine seals, and other parts of the affected vessel, and change components if necessary. Log all data and record corrective measures taken.

As a minimum requirement, record data 1, 24, and 48 hours after start-up. Use these data points for standard normalization. It is, therefore, critical to correctly calibrate all the instrumentation before the start-up. It is, therefore, crucial to calibrate all instrumentation before the start-up.

TMM-220Section page
4 of 8**START-UP CHECKLIST FOR RO**

As a minimum, consider the following data to record during the initial operation:

1. Feed conditions:

- RO feed pressure
- Water temperature
- TDS (conductivity)
- pH
- Silt Density fouling index (SDI₁₅)
- Turbidity (NTU)
- Chlorine (must be not detectable*),

2. Brine:

- Flow
- TDS (conductivity),
- pH

3. Permeate:

- Permeate flow of each stage (and total system)
- TDS (conductivity) from each vessel and total system.
- Permeate pressure (for each bank)

4. Differential pressure across each RO bank,

It is recommended to take feed water, brine water and permeate water samples to analyze individual ions.

A typical data log sheet is shown in section **TMM-230 Operation Monitoring**.

*) If NaHSO₃ is dosed for chlorine removal, a minimum of 0.5 mg/L HSO₃ must be detectable in brine at any time to ensure full removal of chlorine.

Regular Start-up Checklist for Daily Operation

1. Check feed water quality is meeting recommendations for membrane elements loaded in the system.
2. Flush the RO system with pre-treated feed water at low feed pressure before starting the high-pressure pump to remove air from the system.

NOTE: Following instructions are for a “generic” start procedure for a system using a centrifugal pump with feed and brine flow control valves. Refer to the section “General Start-up procedures for different High-pressure pump (HPP) configurations for other options.”

The regulating valve between the high-pressure pump discharge and membranes should be nearly closed at a high-pressure pump start-up to avoid excessive flows and a water hammer.

START-UP CHECKLIST FOR RO**TMM-220**Section page
5 of 8

3. Gradually increase feed pressure and feed flow rate to RO elements while throttling the brine flow rate. Avoid excessive flow rates and differential pressures across RO banks during start-up.

CAUTION. The maximum pressure drop across any vessel is 0.34 MPa (50 psi) for TM-element types. The product specification sheets state details for each element type.



4. Adjust RO operating parameters to design permeate and brine flow rates. The recovery ratio is defined as the permeate flow over feed water flow. Do not exceed the design recovery ratio during any stage of operation.
5. Discard permeate water to drain until the required water quality is achieved.

Parameters for Start-up Procedures

The following parameters must be maintained during the start-up of RO systems. The design and control of the RO system must be suitable to ensure that the following can be maintained.

1. Pressure increase ≤ 0.07 MPa (10 psi) / sec at any time during the start-up sequence of SWRO.
2. Pressure increase ≤ 0.034 MPa (5 psi) / sec at any time during the start-up sequence of BWRO.
3. Feed flow increase $\leq 5\%$ / sec of final flow.
4. Permeate pressure is lower than brine pressure at all times, especially during flushing and transient conditions during the start-up sequence.

INSTRUCTION. Clean the inside of the pressure vessels if they are dirty. Use a soft mop or swab, occasionally flushing with pre-treated water. Care must be taken not to scratch the inside surface of the vessels.



CAUTION. The installation of check valves alone on the permeate header may be insufficient to ensure requirement #4, especially with ultra-low pressure element types. During flushing, ensure that the permeate line is truly at atmospheric pressure and permeate pressure is always lower than brine pressure. Alternatively, direct the brine and permeate flows to one common discharge line during the flushing sequence, ensuring equal static water column for both streams.



INSTRUCTION: Keep the ramp down period within the following ranges for normal shut down:



Seawater membrane: Ramp down period >60 sec

Brackish water membrane: Ramp down period >30 sec

TMM-220Section page
6 of 8**START-UP CHECKLIST FOR RO****General Start-up Procedures for Different High-Pressure Pump (HPP) Configurations**

NOTE: The information provided here is for general reference only. Pumps, energy recovery devices (ERD's), and associated control equipment are not supplied by or operated by Toray. Toray accepts no liability, which may result from incorrect usage or installation of such devices. Consult your OEM equipment manual or the pump supplier for information regarding the safe operation of specific pump models on your system. For detailed instructions regarding the safe operation of energy recovery devices (ERD's), please consult your OEM equipment manual, or contact your ERD supplier.

This section describes typical start-up procedures, sorted by type of HPP.

RO systems will usually employ one of those four different types of high-pressure pumps:

- 1) Plunger (displacement) pump system with a constant speed motor (**Figure TMM-220-1**)
 1. Open brine control valve (VB), to approx. 50%.
 2. Open relief loop valve (VR).
 3. Close feed pressure control valve (VF), if installed.
 4. Start the high-pressure pump (HPP).
 5. Slowly open VF and close VR until brine flow reaches design value.
 6. Close VB until brine flow starts decreasing. Feed pressure now starts to increase.
 7. Check feed pressure, pressure drop and permeate flow.
 8. Repeat procedure 5–7 until permeate and brine flow match design.

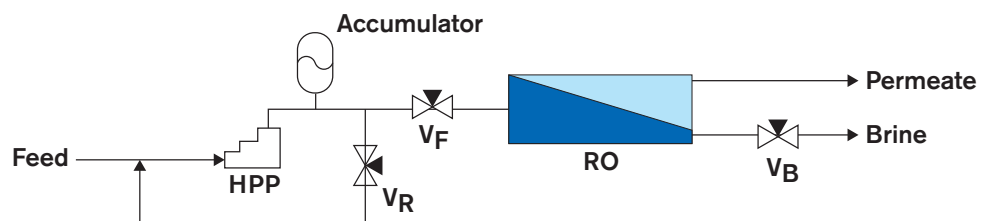

Figure TMM-220-1:
Plunger (displacement) pump system with constant speed motor

START-UP CHECKLIST FOR RO**TMM-220**Section page
7 of 8

- 2) Centrifugal pump system with a constant speed motor (**Figure TMM-220-2**)
 1. Open brine flow control valve (VB) to approximately 50%.
 2. Open minimum flow valve (VM).
 3. Close feed pressure control valve (VF). If no VM is installed, throttle to minimum flow.
 4. Start the high-pressure pump (HPP).
 5. Slowly open VF until brine flow reaches design value (observe note!).
 6. When minimum flow for HPP is reached, close VM (if installed).
 7. Close VB until brine flow starts decreasing. Feed pressure now starts to increase.
 8. Check feed pressure, pressure drop, and permeate flow.
 9. Repeat procedure 5-7 step by step until permeate and brine flow match design.

Note: If excessive brine flow is obtained at point 4 (watch ΔP), brine flow control valve VB must be throttled from step (1).

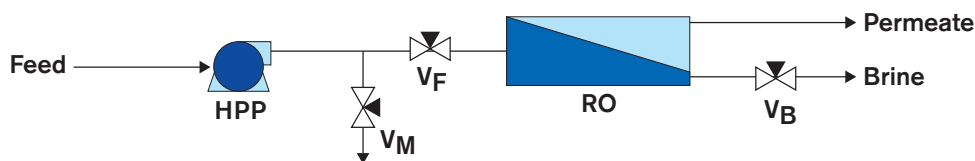

Figure TMM-220-2: Centrifugal pump system with constant speed motor

- 3) Centrifugal pump system with constant speed motor and soft start (**Figure TMM-220-3**)
 1. Open brine flow control valve (VB).
 2. Throttle the feed pressure control valve (VF) to approximately 10%.
 3. Start the high-pressure pump (HPP) (see notes A and B).
 4. Slowly open VF until design brine flow is reached.
 5. Close VB until brine flow starts decreasing. Feed pressure now starts to increase.
 6. Check feed pressure, pressure drop, and permeate flow.
 7. Repeat procedures 4–6 step by step until permeate and brine flow match design.

Note (A): In case excessive brine flow is obtained (watch ΔP), set the brine flow control valve (VB) to the throttled position in advance.

Note (B): To avoid excessive feed flow, throttle the feed valve from the beginning.

TMM-220Section page
8 of 8**START-UP CHECKLIST FOR RO**

Figure TMM-220-3:
Centrifugal pump system with constant speed motor and soft start

- 4) Centrifugal pump system with a frequency-controlled motor (**Figure TMM-220-4**)
1. Open brine flow control valve (VB).
 2. Start the high-pressure pump (HPP) at the minimum frequency (speed).
 3. Increase the speed of HPP until design brine flow is reached.
 4. Close VB until brine flow starts decreasing. Feed pressure now starts to increase.
 5. Check feed pressure, pressure drop, and permeate flow.
 6. Repeat procedure 3–5 step by step until permeate and brine flow match design.

Note: Figures TMM-220-1 to 220-4 are for the general explanation of high-pressure pump start-up procedures only. Some of the necessary equipment and instruments are not shown.

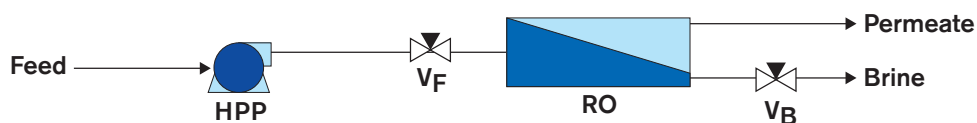
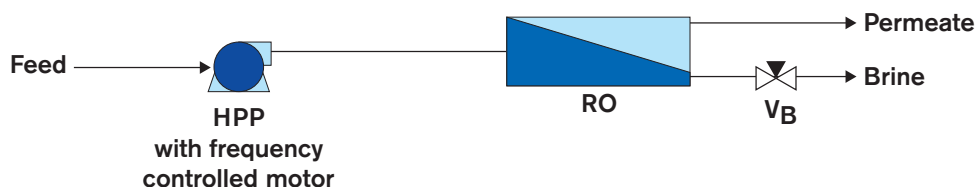

Figure TMM-220-4:
Centrifugal pump system with frequency controlled motor

TMM-230 OPERATION MONITORING

TMM-230

Section page
1 of 15

Monitoring of a RO system's performance is a fundamental prerequisite to ensure dependable RO system performance. Regular RO system performance records will provide a factual basis for troubleshooting and evaluating membrane elements and system performance.

Monitoring

Tables 1.A through Table 1.C lists the operational data for logging and data logging intervals.

Table 1.D summarizes typical water analysis items for periodic comparison to earlier (original) analytical data.

Table 1.E summarizes items for scheduled or system performance related maintenance.

Regular Monitoring and Checkpoints

When feed water quality and operating parameters (such as pressure, temperature, differential pressure, and recovery) are constant, permeate flow rate, and permeate quality should also remain essentially constant ($\pm 5\%$).

If operating parameters change, regular performance normalizations of current data are necessary to compare normalized data to original (start-up) performance values. Confirm that the current normalized performance is in agreement with the initial (start-up) system design parameters.

The frequency of normalizations required will depend on the extent and frequency of variations in feed water quality and operating conditions.

It is also advisable to perform normalization calculations before and after any scheduled maintenance procedures. If, after such maintenance procedures, the normalized performance data indicate significant deviations from original operating parameters, system adjustments may be required to return performance to the initial RO system design parameters.

TMM-230Section page
2 of 15**OPERATION MONITORING****Logbook**

A logbook should be maintained. Record all relevant operational events (however trivial they may seem to be at the time) and their date of occurrence for future reference. Some key operational parameters to record are as follows:

Parameters	Key factors affecting performance
Permeate quality	Feed water chemical composition (total concentration of ions)
	Feed pH
	Feed water temperature
	Pressure of feed, brine and permeate for each stage
	Feed water quality (total ions, colloids and suspended solids; fouling tendency — SDI ₁₅ by Millipore Type HA)
	Recovery (conversion) ratio
Permeate flow rate	Recovery (conversion) ratio
	Pressure at feed, brine and permeate of each stage
	Feed water temperature
	Feed water quality (total ions, colloids and suspended solids; fouling tendency — SDI ₁₅ by Millipore Type HA)

Normalization of System Performance

To effectively evaluate current system membrane element performance, it is necessary to compare current membrane performance data with performance data recorded when the membranes were first placed in service.

As the current operating conditions may be different (i.e., feed salinity, temperature), the current data must be “normalized” to the original start-up operating conditions to allow direct and meaningful comparison. “Normalization,” therefore, refers to manipulating current data to reflect what the flows and quality parameters would be if the plant were operating at the original (start-up) conditions.

By comparing initial membrane performance data (new elements) with current “normalized” membrane performance data, we can determine if any membrane element maintenance (such as a chemical cleaning or system adjustments) is required.

Toray normalization software (TorayTrak) performs these calculations. It is available for download on the Toray web site at free of charge:

Download site: <http://www.toraywater.com>

For general information on TorayTrak, see this section “Normalization program TorayTrak,” page 37.

OPERATION MONITORING

TMM-230

Section page
3 of 15

Precautions and Useful Information for Monitoring Operating Data

Daily monitoring of operating parameters provides a factual basis for the evaluation of RO system performance.

Quick recognition of undesirable trends in normalized operating data allows the timely application of appropriate countermeasures and avoids irreversible damage to membrane elements or other system components.

TMM-310: Guidelines for RO Cleaning describe the guidelines for maintenance, such as recommendations for cleaning.

Troubleshooting guidelines are described in the sections **TMM-600: Introduction to Troubleshooting** and **TMM-610: Typical Performance Changes and Countermeasures**.

Typical signs of system performance change are covered in section **TMM-610: Typical Performance Changes and Countermeasures**.

A graph of normalized performance data is highly recommended to evaluate actual system status and detect trends early (see **Figure TMM-230-1**).

For specific projects and special membrane element applications, please consult the Toray warranty for particular conditions and requirements regarding the extent and frequency of plant monitoring.

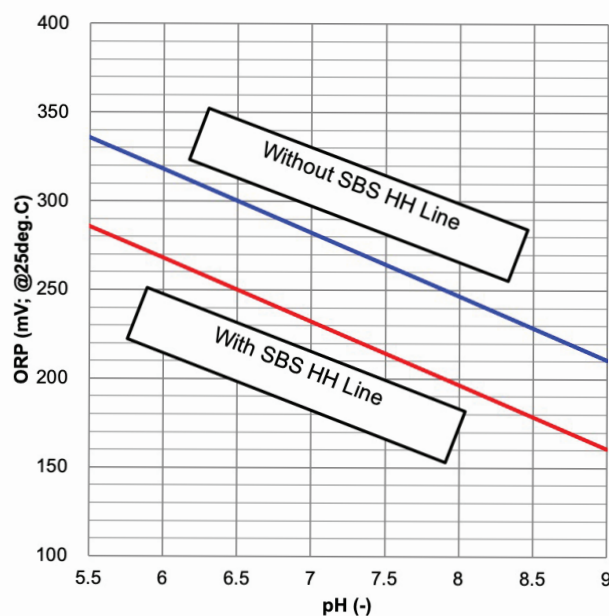

Figure 230-1:
HH lines for controlling ORP value in feed water

RO System Operating Parameters and Logging Intervals

Table 1.A: Softened drinking or well water, SDI ≤ 2, peak 3; NTU ≤ 0.05, peak 0.1

Parameters	Online Monitoring (continuous)	Daily (datasheet)	Periodically ⁽¹⁾	Alarm & Safety System
1. Date and time of data logging		X		
2. Total operating hours		X		
3. Number of vessels in operation			X	
4. Feed water conductivity	X ⁽²⁾	X		
5. Total hardness		X		X
6. Feed water pH	X	X	X	
7. Feed water FI (SDI ₁₅)		X		
8. Feed water temperature	X ⁽³⁾	X		X ⁽³⁾
9. Feed water pressure	X	X		X
10. Feed water chlorine concentration	X ⁽⁴⁾	X ⁽⁴⁾		X ⁽⁴⁾
11. Feed water ORP *)	X ⁽⁵⁾	X		
12. Brine surplus of HSO ₃ ⁻ (≥0.5 mg/L **)		X		X
13. Feed water individual ion concentration			X ⁽⁵⁾	
14. Brine conductivity		X		
15. Brine pH	X ⁽⁷⁾		X	
16. Pressure drop of each bank	X	X		X
17. Brine flow rate	X	X		X
18. Total permeate conductivity	X	X		X
19. Permeate conductivity of each vessel			X	
20. Permeate pressure	X ⁽⁵⁾	X		X ⁽⁵⁾
21. Total permeate flow rate	X	X		X
22. Permeate flow rate for each bank		X		
23. Permeate individual ion concentration			X ⁽⁵⁾	
24. Total recovery ratio		X		
25. Recovery ratio for each bank			X	
26. Normalized salt passage			X	
27. Normalized permeate flow rate			X	
28. Brine pressure	X	X		
29. Brine pressure - permeate pressure	X	X		X

*) The ORP meter reading should always be less than the value of the line shown in Figure 230-1.

**) HSO₃⁻ surplus in brine ≥ 0.5 mg/L if raw water is chlorinated

OPERATION MONITORING

TMM-230

Section page
5 of 15

Notes:

- (1) Log these parameters monthly from the initial start-up operation. In case of troubleshooting or fluctuating operating conditions, the operating party is requested to check these parameters more frequently, depending on the particular situation.
- (2) In case of significant fluctuations.
- (3) In case of high fluctuations or heat exchanger systems.
- (4) If chlorine is detected in the feed water, the plant must be stopped immediately and flushed with chlorine-free water.
- (5) In the case of fluctuating pressure ≥ 0.5 MPa, closed permeate loop or (automatic) valve → risk of water hammer.
- (6) The recommended procedure is water analysis of individual ions, comparing results with projected data. Table 1D lists the required typical ions.
- (7) In case of high fluctuations or acid dosing.
- (8) In the case of prechlorination/dechlorination only.

TMM-230

OPERATION MONITORING

Section page
6 of 15**Table 1.B: Drinking or well water, SDI ≤ 3, peak 4; NTU ≤ 0.05, peak 0.1**

Parameters	Online Monitoring (continuously)	Daily (datasheet)	Periodically ⁽¹⁾	Alarm & Safety System
1. Date and time of data logging		X		
2. Total operating hours		X		
3. Number of vessels in operation		X	X	
4. Feed water conductivity	X ⁽²⁾	X		
5. Feed water pH	X ⁽³⁾	X		X ⁽³⁾
6. Feed water FI (SDI ₁₅)		X		
7. Feed water turbidity (NTU)	X		X	
8. Feed water temperature	X ⁽⁴⁾	X		X ⁽⁴⁾
9. Feed water pressure	X	X		X
10. Feed water chlorine concentration	X ⁽⁵⁾	X ⁽⁵⁾		X ⁽⁵⁾
11. Feed water ORP *)	X ⁽⁹⁾	X		
12. Brine surplus of HSO ₃ ⁻ (≥ 0.5 mg/L **)		X ⁽⁸⁾		X
13. Antiscalant concentration in feed water		X		X ⁽⁵⁾
14. Feed water individual ion concentration			X ⁽⁵⁾	
15. Brine conductivity		X		
16. Brine pH	X ⁽³⁾	X		
17. Pressure drop of each bank	X	X		X
18. Brine flow rate	X	X		X
19. Total permeate conductivity	X	X		X
20. Permeate conductivity of each vessel			X	
21. Permeate pressure	X ⁽⁷⁾	X		X ⁽⁷⁾
22. Total permeate flow rate	X	X		X
23. Permeate flow rate for each bank		X		
24. Permeate individual ion concentration			X ⁽⁵⁾	
25. Total recovery ratio		X		X
26. Recovery ratio for each bank			X	
27. Normalized salt passage			X	
28. Normalized permeate flow rate			X	
29. Brine pressure	X	X		
30. Brine pressure - permeate pressure	X	X		X

*) The ORP meter reading should always be less than the value of the line shown in Figure 230-1.

**) HSO₃⁻ surplus in brine ≥ 0.5 mg/L if raw water is chlorinated

OPERATION MONITORING

TMM-230

Section page
7 of 15

Notes:

- (1) Log these parameters monthly from the initial start-up operation. In case of troubleshooting or fluctuating operating conditions, the operating party is requested to check these parameters more frequently, depending on the particular situation.
- (2) In case of significant fluctuations.
- (3) In case of high fluctuations or acid dosing.
- (4) In case of high fluctuations or heat exchange system.
- (5) If there is any possibility of chlorine content in the feed water.
- (6) Recommended procedure is water analysis of individual ions, comparing results with projected data. Table 1D lists the required typical ions.
- (7) In the case of fluctuating pressure ≥ 0.5 MPa, closed permeate loop or (automatic) valve → risk of water hammer.
- (8) Volumetric recording of daily consumption, divided by total daily feed flow and brine flow respectively.
- (9) In the case of prechlorination/dechlorination only.

TMM-230

Section page
8 of 15

OPERATION MONITORING

Table 1.C: Surface water / Tertiary effluent, SDI ≤ 4, peak 5; NTU ≤ 0.05, peak 0.1

Parameters	Online Monitoring (continuously)	Daily (datasheet)	Periodically ⁽¹⁾	Alarm & Safety System
1. Date and time of data logging		X		
2. Total operating hours		X		
3. Number of vessels in operation		X		
4. Feed water conductivity	X	X		
5. Feed water pH	X	X		X
6. Feed water FI (SDI ₁₅)		X		
7. Feed water turbidity (NTU)	X	X		X
8. Feed water temperature	X	X		X
9. Feed water pressure	X	X		X
10. Feed water chlorine concentration	X	X		X
11. Feed water ORP *)	X	X		
12. Brine surplus of HSO ₃ ⁻ (≥ 0.5 mg/L **)		X		X
13. Antiscalant concentration in feed water		X		X
14. Feed water individual ion concentration			X ⁽²⁾	
15. Brine conductivity		X		
16. Brine pH	X	X		
17. Pressure drop of each bank	X	X		X
18. Brine flow rate	X	X		X
19. Total permeate conductivity	X	X		X
20. Permeate conductivity of each vessel			X	
21. Permeate pressure	X	X		X
22. Total permeate flow rate	X	X		X
23. Permeate flow rate for each bank		X		
24. Permeate individual ion concentration			X ⁽²⁾	
25. Total recovery ratio		X		X
26. Recovery ratio for each bank			X	
27. Normalized salt passage			X	
28. Normalized permeate flow rate			X	
29. Brine pressure	X	X		
30. Brine pressure - permeate pressure	X	X		X

*) The ORP meter reading should always be less than the value of the line shown in the Figure 230-1.

**) HSO₃⁻ surplus in brine ≥ 0.5 mg/L if raw water is chlorinated.

Notes:

- (1) Log these parameters monthly from initial start-up operation. For trouble shooting or fluctuating operating conditions, additional check-ups are required, depending on particular situation.
- (2) Recommended procedure is water analysis of individual ions, comparing results with projected data. Required typical ions are listed in Table 1D.

OPERATION MONITORING

TMM-230

Section page
9 of 15

Table 1.D: Typical Water Analysis Items

Items	Unit or Abbreviation	Feed water	Permeate
1. Conductivity (25°C)	μS/cm	X ⁽¹⁾	X
2. Total dissolved solids	TDS	X	X
3. pH	—	X	X
4. Chloride	Cl ⁻	X ⁽¹⁾	X
5. Nitrate	NO ₃ ⁻	X	X
6. Bicarbonate	HCO ₃ ⁻	X ⁽¹⁾	X
7. Sulfate	SO ₄ ²⁻	X	X
8. Phosphate	PO ₄ ³⁻	X	
9. Fluoride	F ⁻	X	
10. Sodium	Na ⁺	X	X
11. Potassium	K ⁺	X	X
12. Ammonium	NH ₄ ⁺	X	
13. Calcium	Ca ²⁺	X ⁽¹⁾	X
14. Magnesium	Mg ²⁺	X ⁽¹⁾	X
15. Strontium	Sr ²⁺	X	
16. Barium	Ba ²⁺	X	
17. Iron as ion	Fe ³⁺	X	
18. Manganese	Mn ²⁺	X	
19. Silicate	SiO ₂	X	X
20. Silicic acid	SiO ₃ ⁻	X	X
21. Boron	B	X ⁽²⁾	X ⁽¹⁾
22. Chemical oxygen demand	COD	X	
23. Biological oxygen demand	BOD	X	
24. Total organic carbon	TOC	X	X
25. Carbon dioxide	CO ₂	X	
26. Microorganism	unit/cc	X	
27. Hydrogen sulfide	H ₂ S	X	
28. Temperature	°C	X	

Note:

The above table is for reference only. The selection of required ions for analysis will also depend on the feed water and target permeate qualities.

(1) These values constitute the minimum information required for a qualified RO lay-out. Ions not analyzed will not be available for calculation of scaling potentials.

(2) In case of specified data for permeate quality.

TMM-230Section page
10 of 15**OPERATION MONITORING****Table 1.E: RO system maintenance items (to be noted in system log)**

Items	Frequency & Procedure
1. Instruments Pressure sensors & indicators System control devices Safety shutdown facilities	Perform regular calibration and maintenance according to the maintenance manual supplied by the manufacturer.
2. Cartridge filter change Use only new pre-washed filter cartridges free of surfactants and chemical additives introduced during cartridge filter manufacture.	Record the differential pressures of the cartridge filter housing before and after installation of cartridge filters. It is also beneficial to record the date of installation and filter model number.
3. RO system cleaning As a minimum, record the following: Type of cleaning solution, solution concentration and conditions during the cleaning (pressure, temperature, flows, pH, conductivity).	Perform according to the maintenance manual supplied by the system manufacturer. TORAY membrane element cleaning guidelines and instructions are referenced in TMM Sections 310 and 320.
4. Membrane treatment upon shutdown Record preservation method, the concentration of the preservative solution, operating conditions before shut-down and shut-down duration.	Perform according to system manufacturer's operating manual. TORAY guidelines & instructions for long and short term membrane element preservation can be found in TMM sections 240 and 260.
5. Pretreatment operating data RO system performance depends mainly on the proper operation of the pretreatment systems.	Residual chlorine concentration, discharge pressure of booster pump, consumption of all chemicals, calibration of gauges and meters.
6. Maintenance Log	Record any routine system maintenance procedures, mechanical failure events and change of position or replacement of any membrane elements.

OPERATION MONITORING

TMM-230

Section page
11 of 15

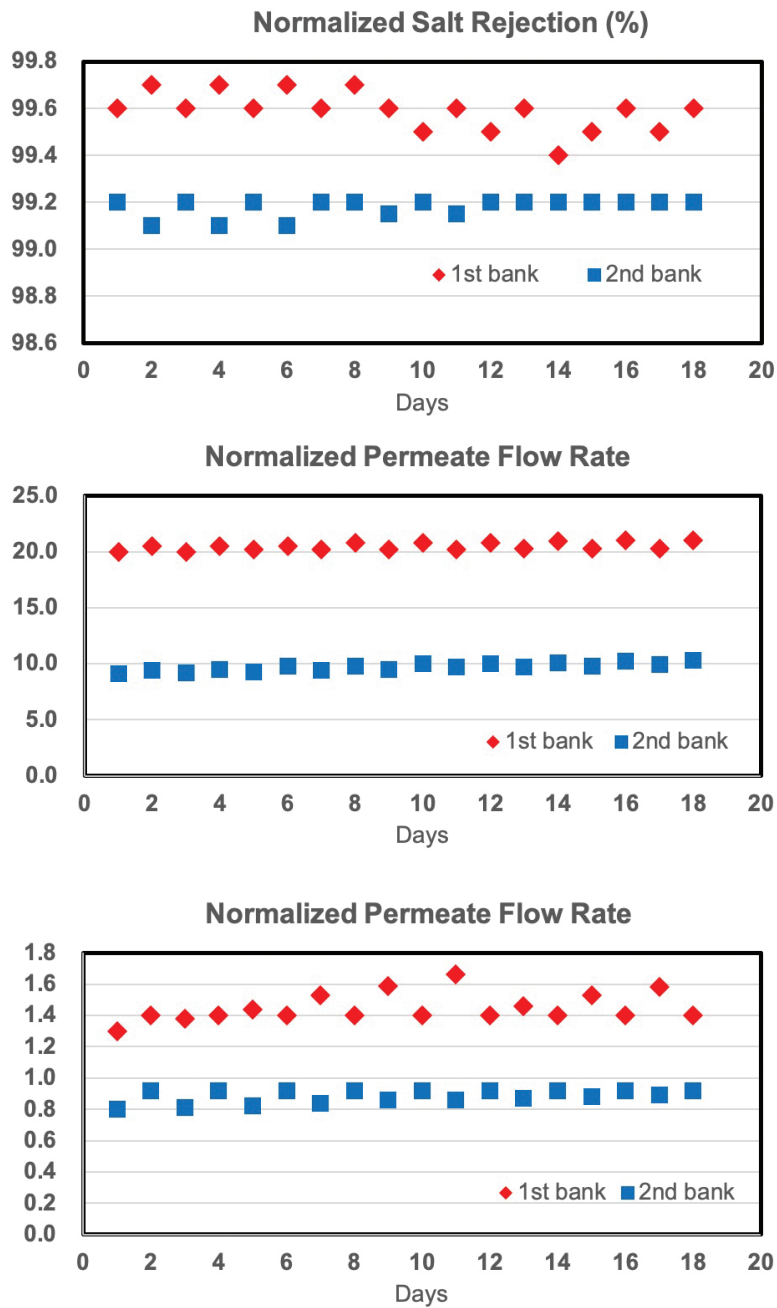

Figure TMM-230-2: Typical monitoring charts for RO systems

TMM-230Section page
12 of 15**OPERATION MONITORING**

Daily monitoring and data normalization are recommended. Watch out for performance change trends. As the current operating conditions may be different (i.e., feed salinity, temperature), the current data must be “normalized” to the original start-up operating conditions to allow direct and meaningful comparison. “Normalization,” therefore, refers to manipulating current data to reflect what the flows and quality parameters would be if the plant were operating at the original (start-up) conditions.

In **Figure TMM-230-2**, no performance changes are indicated, which is typical for proper system operation.

By comparing initial membrane performance data (new elements) with current “normalized” membrane performance data, it is possible to determine if any membrane element maintenance (such as a chemical cleaning or system adjustments) will be required.

Normalization Program — TorayTrak

To assist in RO system performance and data normalization, TORAY developed a RO performance data normalization program called TorayTrak. TorayTrak is available for download at the Toray web site www.toraywater.com free of charge.

Toray provides TorayTrak as a Macro-Free Microsoft Excel program with five versions to handle different process system designs and varied operational data collection points. The process schemes available are:

- A. A one-stage system: [TorayTrak_OneStage_PTotal.xlsx](#)
- B. A split permeate one-stage system: [TorayTrak_OneStage_Split.xlsx](#)
- C. A two-stage system with first and second stage permeate flow rate monitoring: [TorayTrak_TwoStage_PF1_PF2.xlsx](#)
- D. A two-stage system with first stage and overall permeate flow rate monitoring: [TorayTrak_TwoStage_PTotal_PF1.xlsx](#)
- E. A two-stage system with second stage and overall permeate flow rate monitoring: [TorayTrak_TwoStage_PTotal_PF2.xlsx](#)

Procedures for normalization are given in ASTM D 4516.

The following is a general introduction to TorayTrak for a one-stage system as an example.

OPERATION MONITORING

1) Configuration

TORAY Membrane performance Normalization Workbook

Toray Trak Excel Single (1) Stage System, Total Perm Flow
3.0.2 Version - NO MACROS
2018/1/12 Date Released

ENTER SITE SPECIFIC INFORMATION BELOW

Overall	STAGE 2 - not used	STAGE 3 - not used	
Select Element Model TM720L-400	TM720L-400	TM720L-400	
Select Number of vessels/stage 2	not used	not used	
Select Number of elements/vessel 6	not used	not used	
Number of elements/stage and total 12.00	not used	not used	12.00 TOTAL ELEMENTS
Membrane area/stage and total 447.60	not used	not used	447.60 TOTAL AREA M ²
Flux/stage and total 5.68	not used	not used	5.68 Average Reference Flux (GFD)
Baseline permeate flow/stage and total 19.00 gpm	not used	not used	19.00 Baseline Permeate Flow Rate
Select TEMPERATURE Units C	DO NOT CHANGE THIS AREA!!		<== Select Temperature Units
Select PRESSURE Units bar	C TempUnits		<== Select Pressure Units
Select FLOW Units gpm	bar PressUnits		<== Select Flow Units
	gpm FlowUnits		

NOTE: If you change anything here, recalculate the whole sheet Ctrl+Alt+F9

1.

1. Left-click your mouse on the "Configuration" Tab. All required system information is in green fill.
2. From the drop-down lists, enter Toray membrane model numbers, enter the number of pressure vessels (PV), and the number of elements per pressure vessel.
3. Next, select the desired engineering units. These units must remain consistent for all data entries in the workbook.

TMM-230

Section page
14 of 15

OPERATION MONITORING

2) Input data

1	A	B	C	D	E	F	G	H	I	J	K
1	C		< Temperature Units Selected. Use Sheet CONFIGURATION to change								
2	bar		< Pressure Units Selected. Use Sheet CONFIGURATION to change								
3	Data Entry Cells are YELLOW with Black Text										
4	USE CONFIGURATION SHEET FOR UNITS ==>			c	uS	uS	gpm	gpm	bar	bar	bar
5	DATE & TIME	Elapsed Time day	Comments	Temp	Feed uS	Overall Perm uS	Overall Perm Flow	Conc Flow	Feed Press	Final Conc Press	Perm Press
6	2015/1/8 0:00		<First Data goes here>	25.0	7283.1	27	19.00	9.5	12.3	11.7	0.1
7	2015/1/7 0:00	1	Tp for cleaner graphs -	25.0	7283.1	27.4	19.00	9.50	12.29	11.70	0.09
8	2015/1/8 0:00	2	Only add a date when you have data	25.0	7283.1	27.4	19.00	9.50	12.29	11.70	0.09
9	2015/1/9 0:00	3	Formulas exist to row -200 below	25.0	7283.1	27.4	19.00	9.50	12.29	11.70	0.09
10	2015/1/10 0:00	4	R200, copy row to add more data	25.0	7283.1	27.4	19.00	9.50	12.29	11.70	0.09
11	2015/1/11 0:00	5		25.0	7283.1	27.4	19.00	9.50	12.29	11.70	0.09
12	2015/1/12 0:00	6		5.0	7283.1	13.4	19.00	9.50	22.26	21.31	0.09
13	2015/1/13 0:00	7		7.0	7283.1	14.3	19.00	9.50	20.70	19.85	0.09
14	2015/1/14 0:00	8		9.0	7283.1	15.2	19.00	9.50	19.40	18.54	0.09
15	2015/1/15 0:00	9		11.0	7283.1	16.3	19.00	9.50	18.18	17.38	0.09
16	2015/1/16 0:00	10		13.0	7283.1	17.5	19.00	9.50	17.07	16.29	0.09
17	2015/1/17 0:00	11		15.0	7283.1	18.8	19.00	9.50	16.07	15.33	0.09
18	2015/1/18 0:00	12		17.0	7283.1	20.2	19.00	9.50	15.16	14.48	0.09
19	2015/1/19 0:00	13		19.0	7283.1	21.8	19.00	9.50	14.34	13.88	0.09
20	2015/1/20 0:00	14		21.0	7283.1	23.0	19.00	9.50	13.58	12.90	0.09
21	2015/1/21 0:00	15		23.0	7283.1	25.3	19.00	9.50	12.91	12.30	0.09
22	2015/1/22 0:00	16		25.0	7283.1	27.4	19.00	9.50	12.29	11.70	0.09
23	2015/1/23 0:00	17		27.0	7283.1	29.9	19.00	9.50	11.78	11.22	0.09
24	2015/1/24 0:00	18		29.0	7283.1	32.8	19.00	9.50	11.36	10.83	0.09

1. Left-click your mouse on the "Data" tab where you will enter the membrane performance data.
2. Starting on row 6, enter membrane performance data in columns A through K. All columns titled in the yellow coloured field after the Date entry must contain data out to column K.
3. Baseline data to establish recommended cleaning lines are generated by averaging the data entered in rows 7–10.

OPERATION MONITORING

TMM-230

Section page
15 of 15

3) Trend graph

"NormPerm," "NormSP," and "NormDP" tabs automatically displays the trend graphs of the normalized membrane performance data by the overall system.

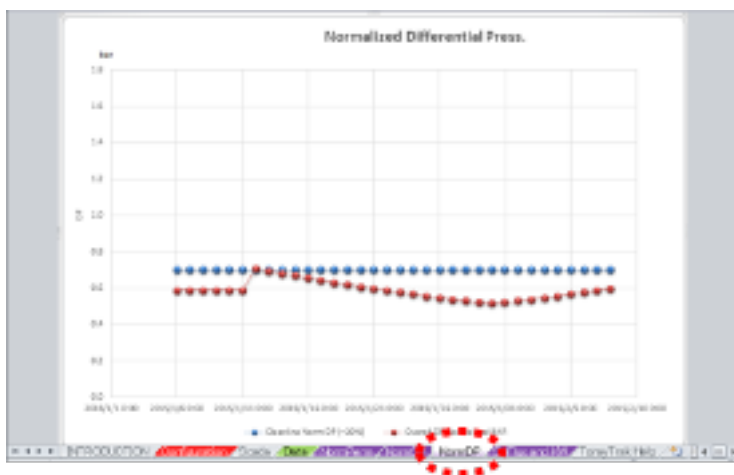
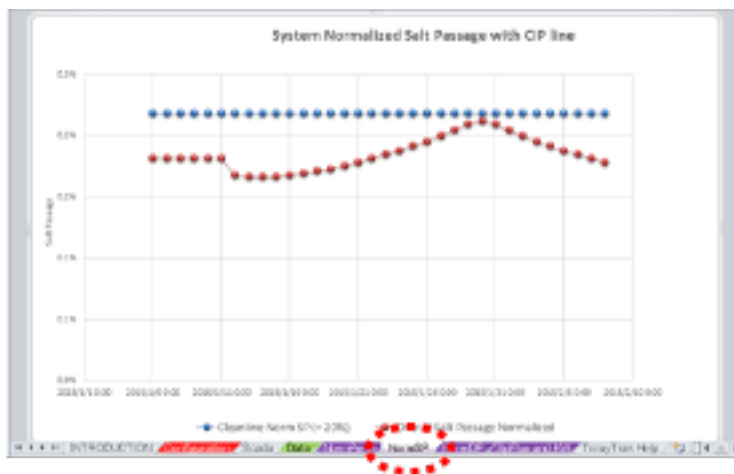
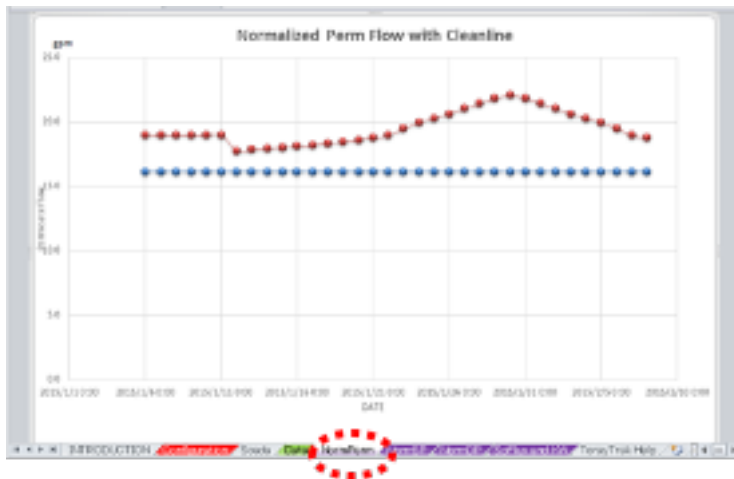

TMM-240Section page
1 of 3**TMM-240 SHUTDOWN CONSIDERATIONS
FOR RO SYSTEMS**

1. When shutting down a RO system, the system should be thoroughly flushed at low pressure with sufficient quality flushing water to displace all the brine from the pressure vessels (**refer to TMM-250 Flushing Procedures**).

Acceptable water for flushing is pre-treated feed water (**refer to Table 240-1**) or RO product water.

Water used for flushing must not contain any oxidants. Maintain the flush water solution pH between 3.0 to 8.5 at all times.

Table 240-1: Suggested flushing water for various RO feed water treatment systems

RO feed water type	Flushing water
Sea water	Pre-treated feed water
Brackish water	Pre-treated feed water
Wastewater	RO product water
High pH feed water (such as 2nd pass high pH feed water)	Pre-treated feed water without NaOH 1st pass product water without NaOH

2. Ensure membrane elements are kept wet, properly sanitized, and protected from freezing during the shutdown period.
3. Ensure guidelines for temperature and pH of the preservative solution are observed during the shutdown period.

Take care that product back pressure never exceeds 0.03 MPa at any time. Assess product back pressure on an individual stage basis. Product back pressure is defined as product pressure minus feed resp. brine pressure.



CAUTION. When multiple RO trains are running in parallel, and one train requires a shutdown, assure that the train to be shutdown is properly isolated from the common header piping using check valves or isolation valves. It is critical that pressure relief valves be present and installed on each train permeate line.

4. Under any circumstances, do not expose any membrane elements to chlorine or other chemical oxidants. Any such exposure may damage the membrane, possibly resulting in an irreversible increase in salt passage.

SHUTDOWN CONSIDERATIONS FOR RO SYSTEMS

TMM-240

Section page
2 of 3

5. Take extra care to avoid chlorine exposure:
 - When disinfecting piping or pre-treatment equipment upstream of the membrane
 - When preparing cleaning or storage solutions
 - Take extra caution to ensure that no trace of chlorine is present in the feed water to the RO membrane elements.
 - If residual chlorine is known to be present in the RO feed, it must be removed with sodium bisulfite (SBS) solution in stoichiometric excess, allowing sufficient contact time to accomplish complete dechlorination.

Short-term Shutdown

Definition:

Short-term shut-down is for periods where an RO plant must remain out of operation for more than one day, but fewer than four days, with the RO elements remaining loaded in the vessels.

Prepare each RO train as follows:

1. Flush the RO section with flushing water, while simultaneously venting any air from the system feed piping.
2. When the pressure vessels are filled with flushing water, isolate the train by closing all isolation valves.
3. Repeat steps 1 and 2 above every 24 hours.

For detailed instructions of flushing procedures, see **TMM-250: Flushing Procedure**.

Long-term Shutdown

Definition:

Long-term shut-down is for periods where an RO plant must remain out of operation for more than four days with the RO elements remaining in the pressure vessels.

Prepare each RO train as follows:

Case. A) Sufficient flushing water is available.

1. Flush the RO system with flushing water for 0.5-1.0 hour, while simultaneously venting any air from the system.
2. When the pressure vessels are filled with flushing water, isolate the train by closing all isolation valves.
3. Repeat 1) and 2) above at least every two days.

For detailed instructions, see **TMM-250 Flushing Procedure**.

TMM-240Section page
3 of 3**SHUTDOWN CONSIDERATIONS FOR RO SYSTEMS****Case. B)** Flushing water is not available.

1. Circulate the permeate through the system. While circulating permeate through the system, inject the RO system, flush line with a 500 to 1000 mg/L (maximum) SBS solution. This solution will serve to inhibit biological growth during the shut down period. Circulate for 30–60 minutes.
2. Make sure the RO system is filled with the SBS solution. To prevent the solution from draining from the system, close all system isolation valves.
3. The pH of the preservative solution should never be allowed to drop below 3.0. Regularly check the pH. If the pH drops below 3.2, drain and replace the preservative solution as soon as possible.
4. If measuring the preservation solution's pH is not possible, repeat steps a) and b) with fresh solution.
 - Every 30 days if the temperature is less than 27°C (80°F)
 - Every 15 days if the temperature is equal to or greater than 27°C (80°F)

Note: Any contact of the SBS solution with air (atmospheric oxygen) will oxidize SBS to sulfate, and the preservative solution pH will begin to drop. Take special care to keep the SBS preservative solution isolated from atmospheric oxygen. If the SBS is allowed to revert to sulfate, the potential for a biological activity will increase.

TMM-250 FLUSHING PROCEDURES

TMM-250

Section page
1 of 1

A straightforward procedure for the removal of foulants is to flush the system with flushing water. Flushing scours the membrane surface by taking advantage of high velocity at low pressure. A large volume of flush water is required. This procedure can be an effective method for removing light organic fouling provided it is applied before there is a significant performance decline.

General operating conditions for flushing are as follows:

Flushing water Use pre-treated feed water (**refer to Table 250-1**) or RO product water.

Flushing water should not contain any oxidants.

Maintain flushing water pH range between 3.0–8.5.

Table 250-1: Flushing water of various RO feed water treatment systems

RO feed water type	Flushing water
Sea water	Pre-treated feed water
Brackish water	Pre-treated feed water
Waste water	RO product water
High pH feed water (i.e., 2nd pass high pH feed water)	Pre-treated feed water without NaOH 1st pass product water without NaOH

Pressure Low pressure (0.1–0.2 MPa [15–30 psi])

Water flow rate High flush water flow rate is best but do not exceed the recommended vessel pressure drop.

Limit pressure drop to max 0.2 MPa [30 psi] per stage.

Maximum feed flow rate per vessel 8-inch element: 200 L/min (53 gpm)
4-inch element: 50 L/min (13 gpm)

Temperature $\leq 40^{\circ}\text{C}$ (104°F)

Period 0.5–1.0 hour

It is important to keep the permeate side isolation valve(s) open to keep the permeate back pressure to a minimum during the flushing procedure.

Feed/brine pressure should always be higher than permeate pressure to avoid any membrane damage.

INSTRUCTION. Flush each stage (bank) separately. Do not re-circulate flushing water.



TMM-260Section page
1 of 2**TMM-260 PRESERVATION OF RO ELEMENT IN PRESSURE VESSEL**

The objective is to store elements under clean conditions to maintain performance and to prevent bacteria growth.



INSTRUCTION. After system shutdown, displace brine in the system with flushing water.

General conditions for preservation:

Flushing water Use pre-treated feed water (**refer to Table 260-1**) or RO product water.

Flushing water should not contain any oxidants

Flushing water pH range should be maintained between 3.0–8.5.

Table 260-1: Flushing water of various RO feed water treatment systems

RO feed water type	Flushing water
Sea water	Pre-treated feed water
Brackish water	Pre-treated feed water
Waste water	RO product water
High pH feed water (i.e., 2nd pass high pH feed water)	Pre-treated feed water without NaOH 1st pass product water without NaOH



CAUTION. If the potential for scaling and fouling exists, RO membranes must be flushed on shutdown according to the procedures outlined in **TMM-250 Flushing Procedures**.

1. Elements must be wet at all times to maintain performance.
2. Sanitization may be required to prevent bacterial growth in the pressure vessels (**see TMM-400: Sanitization Methods**).

PRESERVATION OF RO ELEMENT IN PRESSURE VESSEL

TMM-260

Section page
2 of 2

3. If an extended shutdown is scheduled due to contamination or fouling of the elements, chemical cleaning before preservation is recommended. Doing so removes foulant from membranes and minimizes bacterial growth. Please review:
 - **TMM-300: General Instructions and Conditions for RO Cleaning**
 - **TMM-310: Guidelines for RO Cleaning**
 - **TMM-320: Instructions for Chemical Cleaning.**
4. The allowable temperature range for preservation solutions 5–35°C (41–95°F)
5. The allowable pH range during preservation in the pressure vessel is 3.0–8.5.
6. Make-up water for preservation solution must be free from residual chlorine or other oxidizing agents.

For preserving elements, use sodium bisulfite solution. For details, see section **TMM-400: Sanitization Methods.**

TMM-300Section page
1 of 1**TMM-300 GENERAL INSTRUCTIONS AND
CONDITIONS FOR RO CLEANING**

The surface of an RO membrane is subject to fouling by suspended solids, colloids, and precipitation. Design the pretreatment of feed water before the RO process to avoid contamination/fouling of the membrane surface as much as possible.

Operation at optimum conditions (permeate flow rate, pressure, recovery, and pH-value) will result in less fouling of the membranes.

SDI15 is a measurement of particulates present in the feed water. With high SDI15 values (even in allowable range), membrane fouling due to particulates can cause performance decline in long-term operation.

Fouling can also be a consequence of large variations in raw water quality or RO operation mode errors.

Fouling of the membrane surface will result in a performance decline, i.e., lower permeate flow rate, higher solute passage, increased differential pressure loss from the feed side of a stage to the brine side.

Figure TMM-300-1 illustrates the decrease of flux caused by fouling and restoration of flux achieved through cleaning. If the foulant source is unaddressed and corrected, foulant removal will only bring temporary relief, as indicated by the “sawtooth” pattern of the permeate flow.

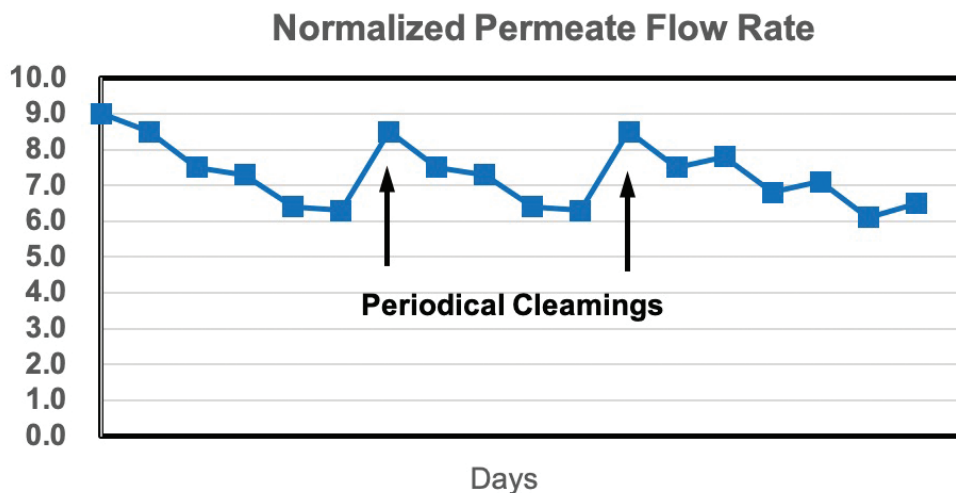

Figure TMM-300-1: Effect of fouling on permeate flow rate

NOTE: The best solution is to remove the foulant through improved pretreatment rather than subject the membranes to repeated cleanings.

TMM-310 GUIDELINES FOR RO CLEANING

TMM-310

Section page
1 of 2

When to Clean:

Cleaning the elements before the fouling has fully developed determines the best cleaning efficiency. Delaying cleaning will render foulant removal from the membrane surface and re-establishing full performance more difficult.

INSTRUCTION. Commence cleaning when:

1. Normalized differential pressure increases more than 20%; or
2. Normalized permeate flow rate decreases by more than 10%; or
3. Normalized salt passage increases by more than 20%.

Weighing an element is an easy check for the occurrence of fouling. If the element's weight is much higher than that of the new element, fouling has occurred. Before weighing the element, stand it vertically on a perforated plate or drain for 60 minutes to drain fluids.

The approximate weights of new elements (drained condition) are:

- 4 inch diameter x 40 inch long: 4 kg,
- 8 inch diameter x 40 inch long (400 ft² membrane area): 15 kg
- 8 inch diameter x 40 inch long (440 ft² membrane area): 16 kg

Determining Foulant Type

Determining the type of foulants on the membrane surface before cleaning is critical. The best approach for this is a chemical analysis of residues collected with a membrane filter during an SDI15 value determination for pre-treated water.

USEFUL TIP. When a chemical analysis is unavailable, it is possible to classify foulants by color and the residue's consistency on the membrane filter. A brownish color residue will typically indicate iron fouling. White or beige color typically indicates silica, loam, calcium scale, or biological fouling. The crystalline constitution is a feature of calcium scales or inorganic colloids. Bio-fouling or organic material will, besides the smell, often show a slimy or sticky consistency.



TMM-310Section page
2 of 2**GUIDELINES FOR RO CLEANING****Selecting the Right Cleaning Procedure**

Select the correct cleaning procedure upon identifying contamination of the membrane surface.

**INSTRUCTIONS.**

- If suspect foulants are metal hydroxides (e.g., ferric hydroxide or calcium scale), acidic cleaning procedures may be most effective (**see TMM-320: Instructions for Chemical Cleaning and TMM-330: Citric Acid Cleaning procedure**).
- If suspect foulant is organic or biological, cleaning with alkaline agents or detergents is recommended (**see TMM-320: Instructions for chemical cleaning and TMM-340: Dodecyl Sodium Sulfate (DSS) Detergent Cleaning Procedure**).

Typical CIP Procedure

1. Flushing with RO permeate to decrease conductivity & neutralize the pH of the feed side.
2. EDTA-4Na cleaning:
 - 1.0wt%, pH 11.0 adjusted with NaOH, 35°C.
 - 1 hr recirculation followed by 1 hr soaking, repeat three times, then, overnight soaking.
3. Rinsing with permeate.
4. Citric acid cleaning.
 - 2.0wt%, No pH adjustment; pH is more than 2.0, 35°C.
 - 1 hr recirculation followed by 1 hr soaking, repeat two times.
5. Rinsing with permeate.



CAUTION. Establish the most effective cleaning regime at the site for the specific foulants. Toray does not guarantee the efficiency of generic cleaning solutions in removing site foulants.

Evaluating Cleaning Effectiveness

Descriptions of various cleaning procedures are given in **TMM-320: Instructions for Chemical Cleaning**. Generally, following recommendations yield desirable results. The pressure drop across the modules should be reduced to the initial value, while the permeate flow rate and solute rejection will be restored.

If performance is not sufficiently improved after cleaning, a different cleaning procedure may lead to a better result. Foulants will frequently adhere to the membrane surface or remain in spacer material. Final removal may take several successive cleaning procedures. As foulants may be present as layers on the membrane surface, alternating acid and alkaline cleanings are more effective than repeated cleans with only one type of cleaner.

TMM-320 INSTRUCTIONS FOR CHEMICAL CLEANING

TMM-320

Section page
1 of 5

General Guidelines

Chemical maintenance cleanings remove contaminants from membrane surfaces by dissolving or separating through physical and chemical interaction with cleaning chemicals.

INSTRUCTIONS. It is a good practice to perform a system flushing before initiating a chemical maintenance cleaning. Perform a chemical cleaning before introducing any chemical preservatives if the RO system is taken offline for an extended time.



After any chemical cleaning, thoroughly flush the system with either pre-treated raw water or permeate to completely remove any residual cleaning chemicals dissolved or suspended solids from the RO system. See section **TMM-250: Flushing Procedures**.

CIP agents	Generic cleaning chemicals are listed in Table 320-1
Make-up water	Softened water or permeate, free of heavy metals, residual chlorine, or other oxidizing agents.
Required quantity of CIP solution	40–80 liters (11–22 US gallons) per 8-inch element depending on the severity of the fouling. 10–20 liters (3–6 US gallons) per 4-inch element depending on the severity of fouling.
CIP pressure	Low pressure: 0.1–0.2 MPa (15–30 psi)
CIP flow rate (recommended flow rate)	100–150 L/min ([25–40 gpm], [6–9 m ³ /h]) per 8-inch vessel; 25–36 L/min ([6.5–10 gpm], [1.5–2.2 m ³ /h]) per 4-inch vessel; The goal is to try and achieve the recommended cleaning flow rates above while keeping the cleaning solution pressure within the CIP pressure range of 15–30 psi.
Min. feed flow rate	50 L/min (13.2 US gallons/min) for each 8-inch vessel. 10 L/min (2.7 US gallons/min) for each 4-inch vessel.

TMM-320Section page
2 of 5**INSTRUCTIONS FOR CHEMICAL CLEANING**

Temperature	The maximum temperature of the cleaning solution depends on the pH of the cleaning solution as below: Temperature $\leq 35^{\circ}\text{C}$ (pH 2–11) Temperature $> 35^{\circ}\text{C}$ and $\leq 45^{\circ}\text{C}$ (pH 2–11) For other pH, please contact Toray.
Cleaning technique	Clean each bank separately. It is also helpful to recirculate the cleaning solution then allow the membranes to soak in the solution. This procedure can be repeated several times to assist in the membrane cleaning process. See below suggested recirculation time intervals.
Recirculation intervals	0.5–1 hour (repeat 2–3 times) monitor solution temperature (see maximum temperatures above).
Soaking period	2–24 hours including recirculation time (times depending on type and degree of fouling).
Method of cleaning	Recirculation followed by soaking of each bank.
Final flushing period	Minimum 1–2 hours, depending on the application.

It is essential to keep any permeate side valves open to keep the permeate back pressure to a minimum during circulation and flushing.

Feed/brine pressure should always be higher than permeate pressure to avoid any membrane damage. See section **TMM-250: Flushing Procedures** for more details on flushing the RO System.



INSTRUCTION. Start circulation with a slow flow increase. For the first 5 minutes, slowly throttle the flow rate to 1/3 of the target flow rate. For the second 5 minutes, increase the flow rate to 2/3 of the target flow rate, and then increase the flow rate to the target flow rate.

INSTRUCTIONS FOR CHEMICAL CLEANING**TMM-320**Section page
3 of 5**Table 320-1: CIP chemicals**

Contamination	CIP chemical	Cleaning conditions	INSTRUCTION. Ref. description
Calcium scale Metal hydroxides Inorganic colloids	Citric acid 1–2 wt%, adjust with ammonia (NH ₃)	pH value: 2-4	10.TMM-330 Citric acid cleaning procedure
Organic matter, bacterial matter*)	Dodecyl Sodium Sulfate (DSS, Sodium Lauryl Sulfate), 0.03–0.2 wt% with alkaline solution; or Polyoxyethylene Sodium Lauryl Sulfate(PSLS), 0.1–0.5 wt% with alkaline solution; or Alkaline solution without organic reagents	pH value : 7-11, adjust with sodium hydroxide; or sodium tripolyphosphate; or trisodium phosphate	11.TMM-340 DSS DSS (Dodecyl Sodium Sulfate) Detergent Cleaning Procedure
Acid insoluble Scaling**) CaF ₂ ; BaSO ₄ ; SrSO ₄ ;CaSO ₄	1 wt% Sodium hexametaphosphate (SHMP)	pH value: 2 adjust with hydrochloric acid	12.TMM-350 Acidic SHMP CIP Procedure



- 1) Alkaline solution with 1 wt% EDTA-4Na is more effective in some cases.
- *) Combining sterilization and detergent cleaning is effective for bacterial contamination. Sequence of sterilization and detergent cleaning depends on the type of fouling and reagents. Detergent cleaning is often performed first followed by sterilization. (see TMM-400 Sanitization methods for RO/NF - elements)
- **) It is recommended to start with an acid cleaning to remove any other (combined) acid soluble fouling materials (such as e.g. CaCO₃). Acid insoluble scaling is difficult or impossible to remove if fouling layer is aged. Cleaning should be done within one week after such scaling is recognized.

TMM-320

Section page
4 of 5

INSTRUCTIONS FOR CHEMICAL CLEANING

Membrane Cleaning System Design Considerations

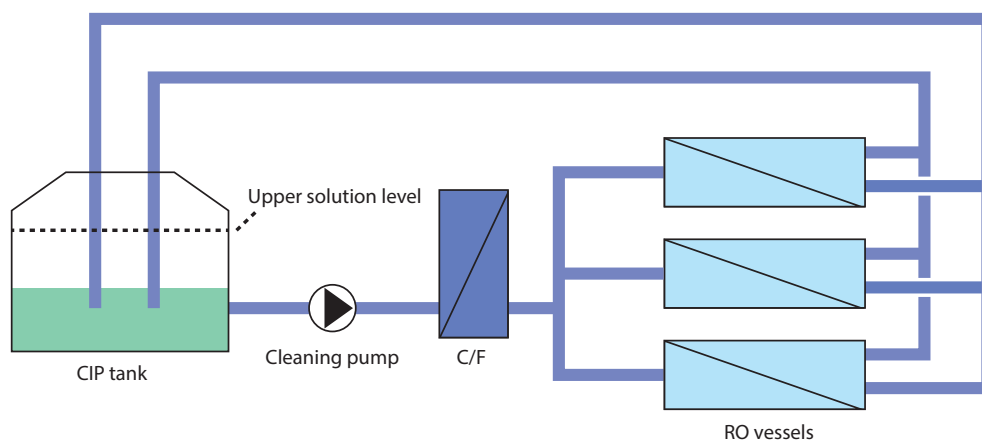

Figure TMM-320-1: Calculation of CIP tank volume

The recommended CIP tank volume, as shown in **Figure TMM-320-1**, is calculated as $(A + B) \times 1.2 + C$, where:

- A = CIP system volume (cleaning system piping and pipe headers)
- B = Volume of water in elements subject to simultaneous cleaning (20 liters [6 US gallons] for 8-inch element, 5 liters [1.3 US gallons] for 4-inch element)
- C = Minimum required volume to run the cleaning pump (this depends on the tank design and cleaning pump specifications such as Net Positive Suction Head (NPSH) requirement)

This CIP tank volume calculation is based on the following CIP procedure.

- 1) Makeup cleaning solution in the CIP tank.
- 2) Feed the cleaning solution to the cleaning system piping, pipe headers and pressure vessels to replace the water inside with the cleaning solution. During this period, the replaced water is flushed out via drain line.
- 3) Flush out initial 10–20% of the cleaning solution since this contains a high concentration of foulant.
- 4) Start CIP solution circulation. Open CIP return valves to CIP tank, and close drain valves.

The cleaning flow rate measured as the discharge flow rate of the cleaning pump should be as follows:

100–150 L/min. ([25–40 gpm], [6–9 m³/h]) per 8-inch vessel;

25–36 L/min. ([6.5–10 gpm], [1.5–2.2 m³/h]) per 4-inch vessel;

The goal is to achieve the recommended maximum flow rate while maintaining a CIP pressure range between 0.1–0.2 MPa (15–30 psi).



INSTRUCTION. Pump head is calculated from:

- Max. differential pressure across RO elements (approx. 0.2 MPa) [30 psi]
- Pressure loss of piping system and pressure vessel connections
- Max. differential pressure across cleaning cartridge filter (approx. 0.2 MPa) [30 psi]

INSTRUCTIONS FOR CHEMICAL CLEANING

TMM-320

Section page
5 of 5

IMPORTANT NOTES:

1. **INSTRUCTION.** Provide a separate return line for permeate. It is important to keep any permeate side valves open to keep permeate back pressure to a minimum during the circulation or flushing procedure. Feed/brine pressure should always be higher than permeate pressure to avoid any membrane damage.
2. **INSTRUCTION.** The design of the cleaning tank must allow for complete draining.
3. **CAUTION.** To avoid excess foaming of cleaning solutions the cleaning solution and permeate return lines should be sufficient length to extend below the solution's level in the CIP cleaning tank.
4. **CAUTION.** Spent cleaning solutions must be neutralized before discharge. Consider local regulations for discharge.
5. **WARNING.** When working with chemicals, follow safety regulations indicated in material safety sheets. Wear suitable protection, such as eye protection, protective gloves, and rubber apron.

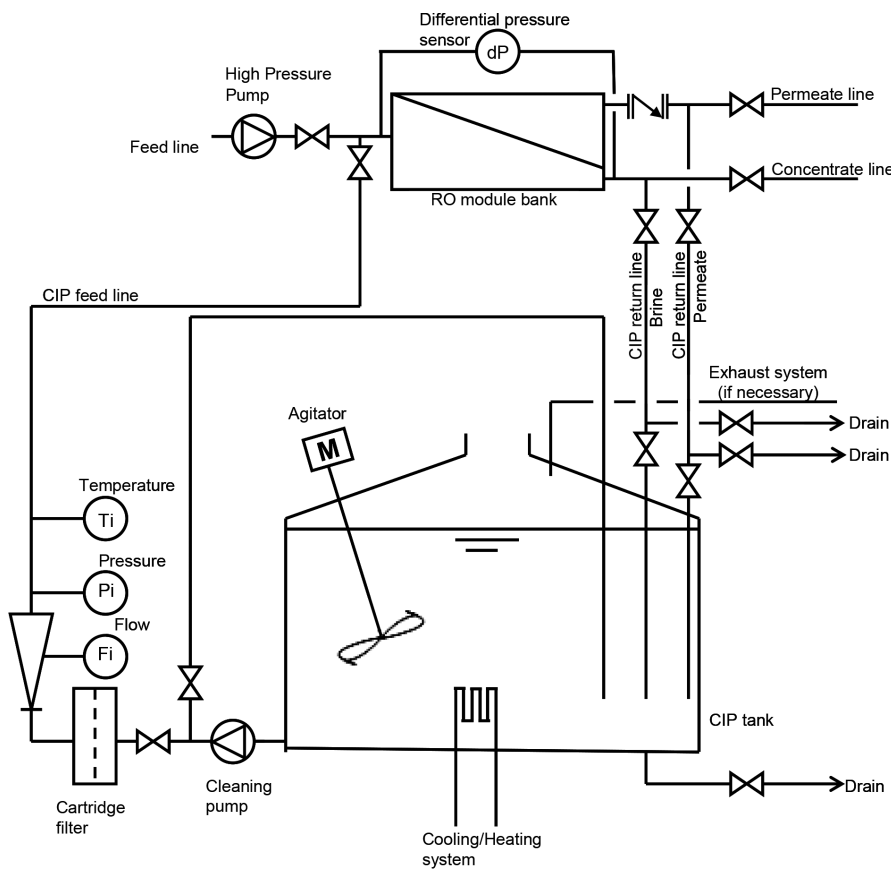

Figure TMM-320-2: Typical CIP system arrangement

TMM-330Section page
1 of 3**TMM-330 CITRIC ACID CLEANING PROCEDURE****Flushing of Elements**

Before cleaning with a citric acid solution, it is advisable (although not mandatory) to flush elements with softened water or RO permeate (**see TMM-250. Flushing procedures**).

Preparing a 2 wt% Citric Acid Solution**1. Fill the cleaning tank with water.**

Fill the cleaning tank with RO permeate or softened water, free of oxidizing agents. Determine the amount of cleaning water by the RO system's size and the extent of fouling (**see TMM-320 Instructions for chemical cleaning**).

2. Dissolve citric acid.

Add citric acid (white powder) in small increments to the cleaning water to obtain a 2 wt% (by weight) — solution. Continuous agitation (or recirculation of the cleaning solution directly from the cleaning pump into the cleaning tank) will dissolve the citric acid wholly and quickly. Break up any large chunks or lumps of citric acid before adding to the tank to avoid damaging the agitator or circulation pump parts.

Example: 20 kg (44 lbs) of citric acid is required to prepare 1,000 liters (264.2 US gallons) of 2 wt% (by weight) solution.

The solution pH should be adjusted with either ammonia (NH₃) or sodium hydroxide (NaOH) to the specified value (**see TMM-320 Instructions for Chemical Cleaning**).

3. Adjusting the solution's pH with ammonium hydroxide should be performed with the agitator or recirculation pump in operation. Use an exhaust system if necessary to draw off ammonia gas that has been released. The use of an electric drum transfer pump or manual drum transfer pump helps minimize ammonia gas release.

The amount of ammonium hydroxide (NH₄OH), required to adjust the pH to 3.5 can be calculated approximately in proportion to the amount of citric acid by the following formula:

$$\text{Amount of NH}_4\text{OH (100\%)} = 0.1 \times \text{Amount of citric acid (100\%)} \text{ in kg}$$

For example, if the calculated amount of citric acid is 20.4 kg, the required amount of ammonium hydroxide (30 wt% by weight) is 6.8 kg = (0.1 x 20.4) / 0.3.

CITRIC ACID CLEANING PROCEDURE

TMM-330

Section page
2 of 3

Circulation of Cleaning Solution

Circulate the cleaning solution at low pressure — less than 0.2 MPa (30 psi) is recommended. Elevated solution temperature will improve cleaning results.

CAUTION. Recirculating the cleaning solution for extended periods improves cleaning efficiency. Monitor the cleaning solution's temperature to ensure it does not exceed the recommended maximum allowable cleaning solution temperature (refer to TMM-320 Instructions for Chemical cleaning).



INSTRUCTION. Soaking elements in the cleaning solution can be an effective procedure to dissolve metal foulants. Alternating soaking intervals with recirculation of the cleaning solution can also be beneficial.



Use citric acid cleanings when the suspected foulant(s) are metal compounds. If the element experiences severe fouling, the citric acid cleaning solution may become less effective as the cleaner reacts with the metal foulant(s). The initial cleaning solution will have a greenish-yellow color. As the metals react with the cleaning solution during the recirculation phase, the color may begin to turn dark yellow, progressing to a darker red-brown. This color shift indicates the impairment of the cleaning solution's effectiveness due to chemical interaction with the foulant(s). Discard the solution when the color of the solution turns darker. Prepare a fresh citric acid solution, and repeat the cleaning procedure to ensure complete and effective cleaning.

Flush Elements

Once the chemical cleaning circulation is finished, completely drain and rinse the cleaning solution tank. Next, fill the cleaning solution tank with permeate or oxidant free feed water. Fill the tank with sufficient flush water to displace all cleaning solution remaining in the cleaning system piping, RO system headers, and pressure vessels. Direct all flush water to drain for proper disposal (refer to TMM-250: Flushing Procedures).

INSTRUCTION. Flush each bank separately. Do not recirculate flushing water.



TMM-330

Section page
3 of 3

CITRIC ACID CLEANING PROCEDURE

General Description of Citric Acid



DANGER	IUPAC name:	2-hydroxypropane-1,2,3-tricarboxylic acid
	Appearance	white crystalline powder
	Density	1665 g/cm ³ (18°C)
	Solubility in water	59 g/100mL (20°C)
	pH	~ 1.7 (100 g/L, 20°C)
	Chemical formula	C ₆ H ₈ O ₇
	Structural formula	
	CAS number:	77-92-9
	Safety precautions	low hazard potential, irritant



INSTRUCTION. Please consult the Safety Data Sheet available from the chemical supplier for full safety details BEFORE handling this chemical. Use all recommended safety equipment.

General Description of Ammonia Solution



DANGER	Appearance	Colourless solution
	Density	0.9 g/cm ³
	pH	~ 11
	Molecular formula	NH ₃
	CAS number:	1336-21-6
	Safety precautions	Corrosive



INSTRUCTION. Please consult the Safety Data Sheet available from the chemical supplier for full safety details BEFORE handling this chemical. Use all recommended safety equipment.

TMM-340 DSS (DODECYL SODIUM SULFATE) DETERGENT CLEANING PROCEDURE

TMM-340

Section page
1 of 3

Flushing of Elements

Before cleaning with DSS solution, it is advisable (although not mandatory) to flush elements with softened water or RO permeate (**see TMM-250: Flushing Procedures**).

Preparing a 0.03 wt% DSS Solution

1. Fill the cleaning tank with water

Fill the cleaning tank with RO permeate or softened water, free of any oxidizing agents. The size of the RO system and the extent of fouling determine the amount of cleaning solution (**see TMM-320: Instructions for Chemical Cleaning**).

2. Dissolve DSS

Add sufficient DSS to the cleaning water to obtain a 0.03 wt% (by weight) solution.

CAUTION. This chemical can form a film on the cleaning water surface, capable of trapping gases. Take precautions to minimize the potential mixing of air with the DSS when making up the cleaning solution to avoid excessive foam formation. It is recommended to dissolve the DSS in a small volume of cleaning water and then add to the bulk solution in the cleaning tank; a continuous and slow agitation of the solution is required to disperse the DSS evenly. To minimize the potential of the formation of foam, use the lowest speed setting on the mixer.

Example: 0.3 kg (0.66 lbs) of DSS is required to produce a 1,000 liters (264.2 US gallons) of the solution.

3. Monitor pH value

Maintain the pH of the detergent solution within the recommended pH range (**see TMM-320: Instructions for Chemical Cleaning**). If the pH falls outside the recommended range, solution pH adjustment will be required. The expected pH of the DSS solution is 7.



Circulate Cleaning Solution

INSTRUCTION. The initial flow of cleaning solution within the cleaning return line may contain a high concentration of contaminants. Discard the initial 10-15% of the cleaning solution volume to drain before circulating the cleaning solution to the cleaning tank.

Increasing the cleaning solution temperature will improve the efficiency of the cleaning. Do not exceed the recommended temperature guidelines. Additionally, it is beneficial to perform the cleaning at low pressures. Do not exceed (approximately 0.2 MPa [30 psi]) during the cleaning solution's circulation.



TMM-340Section page
2 of 3**DSS (DODECYL SODIUM SULFATE) DETERGENT CLEANING PROCEDURE**

CAUTION. Extending the circulation time is beneficial to maximize the efficiency of the cleaning. The cleaning solution temperature should be monitored closely during the circulation of the cleaning solution. Take care not to exceed the recommended maximum temperature value (**refer to TMM-320 Instructions for Chemical Cleaning**).

To minimize the potential for foam formation within the CIP solution tank, make sure the cleaning solution return line and permeate lines extend below the cleaning solution level.



INSTRUCTION. The efficiency of chemical cleanings can be improved if the elements are allowed to soak in the cleaning solution for an extended time. Repeated intervals of soaking, followed by the cleaning solution's circulation, can also improve cleaning results.

Flush Elements

Once the chemical cleaning circulation is finished, completely drain and rinse the cleaning solution tank. Next, fill the cleaning solution tank with permeate or oxidant free feed water. Fill the tank with sufficient flush water to displace all cleaning solution remaining in the cleaning system piping, RO system headers, and pressure vessels. Direct all flush water to drain for proper disposal. Refer to section TMM-250: Flushing Procedures.



INSTRUCTION. Flush each bank separately. Do not recirculate flushing water.

General Description of DSS (Dodecyl Sodium Sulfate)

DANGER	Appearance	Powder or aqueous solution
	Solubility in water	10 g/100 mL
	pH	7–8 (1 wt% solution based on powder)
	Charge in solution	Anionic
	Molecular formula	CH ₃ (CH ₂) ₁₁ SO ₃ Na
	CAS number	151-21-3



INSTRUCTION. Please consult the Safety Data Sheet available from the chemical supplier for full safety details BEFORE handling this chemical. Use all recommended safety equipment.

DSS (DODECYL SODIUM SULFATE) DETERGENT CLEANING PROCEDURE**TMM-340**Section page
3 of 3**General Description of TSP (Trisodium Phosphate)**

DANGER	Appearance	White crystalline powder, granular or chunks
	Density	1.630 g/cm ³ (18°C)
	Solubility in water	28.3 g/100 mL
	pH	Strong alkalinity in solution
	Chemical formula	Na ₃ PO ₄
	CAS number	7601-54-9



INSTRUCTION. Please consult the Safety Data Sheet available from the chemical supplier for full safety details BEFORE handling this chemical. Use all recommended safety equipment.

**General Description of NaOH (Sodium Hydroxide)**

DANGER	Appearance	White crystalline powder, granular or chunks
	Density	2.130 g/cm ³ (18°C)
	Solubility in water	Soluble in random ratio
	pH	Strong alkalinity in solution
	Chemical formula	NaOH
	CAS number	1310-73-2



INSTRUCTION. Please consult the Safety Data Sheet available from the chemical supplier for full safety details BEFORE handling this chemical. Use all recommended safety equipment.



TMM-350Section page
1 of 3**TMM-350 ACIDIC SHMP CIP PROCEDURE****Flushing of Elements**

Before performing this cleaning procedure, it is advisable, especially if operating on raw water having a high total hardness concentration, to flush elements using softened water or RO permeate (**see TMM-250: Flushing Procedures**).

Preparing a 1 wt% SHMP solution

1. Fill the cleaning tank with water.

Fill the cleaning tank with RO permeate or softened water, free of oxidizing agents. Determine the amount of cleaning water by the RO system's size and the extent of fouling (**see TMM-320 Instructions for chemical cleaning**).

2. Dissolve SHMP.

Add SHMP (white powder) to water to obtain a 1% (by weight) solution. Continuous agitation of the solution by a motorized mixer or re-circulation pump will be needed to dissolve the chemical entirely. SHMP should be added to the cleaning tank in small batches to avoid clogging.

Example: 10 kg (22 lbs) of SHMP is needed.

Add hydrochloric acid to prepare 1,000 liters (264.2 US gallons) of the cleaning solution.

3. Add hydrochloric acid.

Slowly add HCl to the SHMP solution until you reach a pH value of 2.



WARNING. HCl is an aggressive inorganic acid, pay attention to safety precautions when handling HCl.

4. Check pH value.

The pH of the cleaning solution should remain just above 2. If the pH increases above 3.5 during circulation of the cleaning solution, add HCl until the pH is again just above pH 2. Should the pH go below 2, adjust the pH to slightly above pH 2 by adding caustic soda (NaOH).



WARNING. Caustic soda is an aggressive inorganic base; pay attention to applicable safety rules when handling it. The expected pH of a 1 wt% SHMP solution is neutral.

Circulate Cleaning Solution

INSTRUCTION. The first 10–15% of the original cleaning solution volume returned from the RO system may contain contaminants in high concentrations. Therefore, it is recommended to dispose of this portion of the cleaning solution to drain and not recycle it back into the solution tank. Once this initial volume has been discarded, direct all the returned cleaning solution to the solution tank for re-circulation.

Apply low feed water pressure during re-circulation (approximately 0.2 MPa [30 psi]). Higher cleaning solution temperature can improve the cleaning efficiency.

ACIDIC SHMP CIP PROCEDURE

TMM-350

Section page
2 of 3

CAUTION. Longer periods of circulation are beneficial for chemical cleanings. However, prolonged circulation will increase the cleaning solution's temperature. Monitor the solution temperature to ensure it does not exceed the recommended maximum allowable temperature (**refer to TMM-320: Instructions for Chemical Cleaning**).



When mixing the SHMP, there is a potential for excessive foaming. To reduce this foaming potential, make sure the permeate and cleaning solution return lines are extended below the liquid level in the cleaning solution tank.

INSTRUCTION. Soaking the elements in the cleaning solution can help to break up and remove contaminants. Alternating periods of soaking and circulation of the cleaning solution can improve the chemical cleaning efficiency.



INSTRUCTION. If the pH value during circulation increases above pH 3.5, add more HCl until pH value drops to just above pH 2. If the pH of the returned cleaning solution increases rapidly, the solution's effectiveness has been reduced due to reaction with contaminants. Should a rapid rise in pH be noted, discard the spent cleaning solution and mix up a fresh batch and proceed as before with the cleaning process.



Flush Elements

At the end of the chemical cleaning process, it will be necessary to flush all the spent cleaning solution from the cleaning piping, RO headers, and pressure vessels. Begin by draining the solution tank and rinse the tank thoroughly. Next, it will be necessary to displace all residual cleaning solution from elements, pressure vessels, and pipelines with feed water or RO permeate.

INSTRUCTION. Flush each bank separately. Do not re-circulate flushing water.



USEFUL TIP. Fill the rinsed cleaning tank with softened water or permeate. Use the cleaning system pump and piping to direct flush water through the RO system. To prevent the spent cleaning solution from mixing with the clean flush water in the cleaning tank, direct all return lines to drain just before the cleaning tank. Repeat as needed to assure complete displacement of the residual cleaning solution (**see TMM-250: Flushing procedures**).



TMM-350Section page
3 of 3**ACIDIC SHMP CIP PROCEDURE****General Description of SHMP (Sodium Hexametaphosphate)**

Appearance	White powder, odourless
Concentration	Approx. 67 wt% as P ₂ O ₅
Density	0.95–1.05 g/cm ³ (20°C)
Solubility in water	Almost unlimited
pH	Approx. pH 7 (1 wt% solution)
Chemical formula	(NaPO ₃) _n
CAS number	10124-56-8



INSTRUCTION. Please consult the Safety Data Sheet available from the chemical supplier for full safety details BEFORE handling this chemical. Use all recommended safety equipment.

Safety precautions

- Consult safety data sheet (SDS) of suppliers of SHMP before use.
- **DANGER.** Wear standard safety equipment like gloves and eye protection during the handling of SHMP.
- In case of eye contact, flush the eye immediately with a large amount of water and consult a physician.
- Avoid prolonged contact with the skin. Avoid breathing dust.

TMM-360 REVERSE FLOW CIP/FLUSHING

During normal operation, the higher operating flux and foulants from upstream exposes the front side RO elements to higher fouling potential.

If CIP or flushing of the RO elements is carried out in the flow direction from the feed side to the brine side, foulant will pass through the downstream RO elements to be discharged from the brine side. This event has potential risks to stack foulant on downstream RO elements.

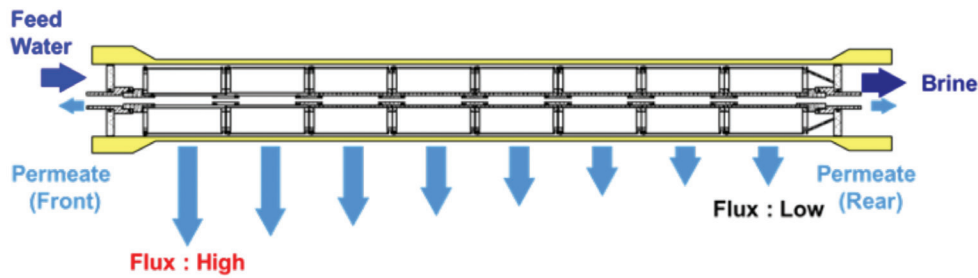

Figure TMM-360-1: Water flow image at normal operation

Reverse flow CIP/Flushing is an efficient cleaning method that helps avoid the stacking of foulants and increase RO elements' lifetime.

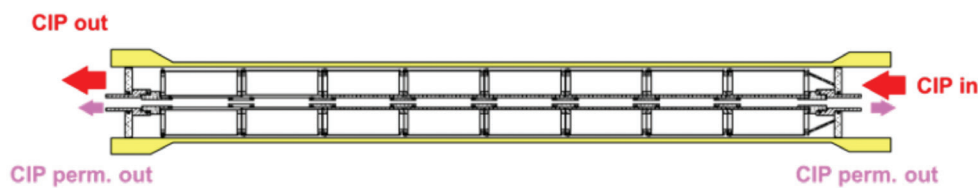
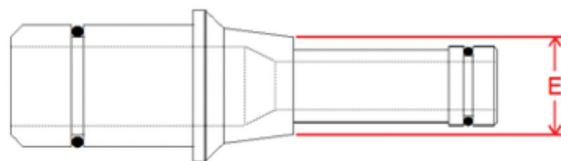

Figure TMM-360-2: Water flow at reverse flow CIP/Flushing

CAUTION. Maximum allowable DP: 2.0 bars/pressure vessel (at reverse flow CIP/Flushing).



Proper shimming is required to avoid the damage of RO element and interconnector o-rings with its movement during reverse flow CIP/Flushing.



The diameter of "E" in the special permeate adapter should be equal or larger than "G."

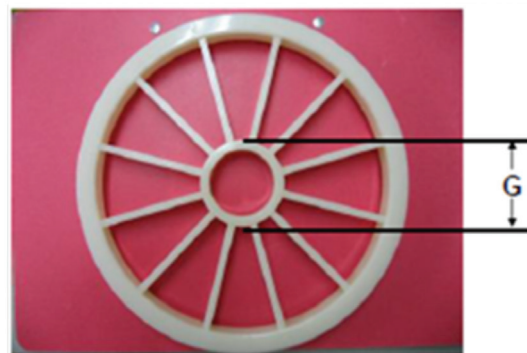

Note: if attempting reverse flow CIP without the special permeate adapter, there is a risk of damaging the elements.

$$E \geq G$$

TMM-400Section page
1 of 2**TMM-400 SANITIZATION METHODS FOR
RO/NF ELEMENTS****Sanitizing Solutions****Formaldehyde**

One effective method to prevent the propagation of bacteria is to soak the membrane elements in a sanitizing solution of 0.2–0.3 wt% formaldehyde (HCHO) at pH 6–8. Adding sodium bicarbonate (NaHCO₃) adjusts the sanitizing solution's pH.

This sanitization method is a satisfactory and effective method to control biological activity for short or long term shutdowns.

Immersion of membrane elements in a formaldehyde sanitization solution does not apply to new elements. Elements must have been in full operation at design conditions for at least 72 hours before any formaldehyde sanitization procedures. Exposure of elements to formaldehyde before 72 hours of operation may result in irreversible flux loss.

Alternate Sanitizing Solutions

If formaldehyde sanitization is not permitted, the following alternative solutions can be employed (see chart below). Membrane elements can be soaked in these alternate solutions during system shutdowns. Please note that membrane exposure time to these alternate solutions is limited. Refer to the chart below for recommended soak intervals.

Table TMM-440-1: Alternate sanitizing solutions

Sanitizing solution	Concentrate (ppm)	Duration of treatment (hour)	Applicable to membrane type
Hydrogen peroxide (H ₂ O ₂ **)	2,000–10,000	1 (**)	Other than 800 series
Sodium bisulfite	500–1,000	No limit (**)	All types

**CAUTION.**

1. The water used to prepare all sanitizing solutions must be free of residual chlorine or other equivalent oxidizing agents.
2. Be sure that the selected chemicals are appropriate and chemically compatible with the membrane type to be sanitized. Refer to the chart above.

SANITIZATION METHODS FOR RO/NF ELEMENTS

TMM-400

Section page
2 of 2

- *1) Contact time with sterilizing solutions must not exceed recommended durations to avoid membrane performance decline.
- **1) The use of hydrogen peroxide in the presence of heavy metal residues will quickly lead to irreversible damage of composite membranes.

Hydrogen peroxide for this application must be prepared with de-ionized feed water with less than 0.2 ppb iron. If the concentration of iron is above 0.2 ppb in the solution's makeup water, the membrane elements can be irreversibly damaged, increasing salt passage.

Any presence or indication of heavy metal precipitates (i.e., iron, manganese) on the membrane surface requires mandatory cleaning of the membranes with an acid solution before exposure to hydrogen peroxide. For details of the citric acid cleaning procedure, see TMM-330: CIP — Citric Acid. Failure to do so may result in catalyzed oxidation of the membrane surface by the hydrogen peroxide resulting in irreversible salt passage increase.

- ***1) After sterilization, thoroughly flush the system with permeate or pre-treated raw water before placing the system back online. If the preservation of membranes is required as part of an extended shutdown, the system must be thoroughly flushed before introducing any preservative solutions.

Biocide

DBNPA (2,2-dibromo-3-nitrilopropionamide) is a highly effective non-oxidizing broad-spectrum biocide used to control algae, bacteria, and fungi in reverse osmosis systems and other industrial water applications.

This product is typically applied as a shock treatment to control biological activity within membrane elements. Dosing frequency depends on the microbiological activity of the RO feed water and the condition of the membranes.

There are several DBNPA-based products available. For more information about DBNPA, refer to DBNPA supplier technical data and Safety Data Sheet or contact your chemical supplier for recommendations.

TMM-410Section page
1 of 1**TMM-410 HEAT SANITIZATION OF RO
ELEMENTS (TS TYPES)**

Periodic hot water sanitization (pasteurization) is a preventive measure to reduce bacteria and fungus growth. The following recommendations apply to TORAY hot water-resistant elements (TS types).

**CAUTION.**

- Temperature slope during heating & cool down period: maximum 2.0°C / minute.
- It is preferable to use permeate, or at least softened water, for this procedure.
- Do not apply heat sanitization to standard RO products, as it will cause irreversible damage.



INSTRUCTION. For effective sanitization, the water temperature can be increased up to 85°C (temperature required depends on bacteria strains present). Increasing the temperature to above 85°C can lead to irreversible damage to the elements.

**CAUTION.**

- Feed pressure during hot water treatment must always be ≤ 0.15 MPa (22 psi).
- The maximum differential pressure should be 0.1 MPa (15 psi) per element.

The frequency of hot water treatment depends on feed water quality and the use of product water. The average frequency of treatment should, however, not exceed one treatment per week.



INSTRUCTION. Microbiological testing of the feed, brine, and permeate streams determine the need for and effectiveness of heat sanitization.

It is important to open the permeate side valve and maintain no permeate side backpressure condition during high-temperature treatment. Feed and brine pressure should be higher than permeate side pressure at all times to avoid permeate back pressure problems.

TMM-500 STORAGE OF RO ELEMENT OUTSIDE OF PRESSURE VESSEL

TMM-500

Section page
1 of 2

General Guidelines

TORAY RO elements must be preserved in a solution to prevent biological growth on membrane surfaces during storage and performance loss in a subsequent operation.

Element preservation is necessary for:

- Long term storage of new and used elements
- RO system shutdown \geq 24 hours

If the RO elements have been in service, see **TMM-240 Shutdown considerations for RO systems**.

Storage of New Elements

Store new elements in its original packaging until installing membrane elements into the pressure vessels for system startup. Recommended storage conditions are listed below:

1. Store elements in a cool and dry place inside a closed building. Keep elements away from exposure to direct sunlight.

Note: New elements are packaged with a preservative solution made of 0.5–1.0% sodium bisulfite or sodium chloride, and a deoxidizer packet.

2. Elements must be stored within a temperature range from freezing point to 35°C (95°F).
3. Oxygen impermeable plastic bags under a slight vacuum are used for packaging new elements. The elements are shipped in durable carton boxes. Store the elements in the original shipping cartons until they are installed in the RO system's pressure vessels. Dispose of used bags and deoxidizers as regular municipal solid waste.
4. Do not stack more than five rows of carton boxes when re-stacking from originally delivered packing (export packing).
5. Please keep the original element packaging dry at all times to preserve structural integrity.

TMM-500Section page
1 of 2**STORAGE OF RO ELEMENT OUTSIDE OF PRESSURE VESSEL****Storage of Used Elements**

1. For storing elements that have been in service, refer to **TMM-240: Shutdown Consideration for RO Systems**. Using RO permeate or softened water, prepare a 500–1,000 ppm sodium bisulfite solution. To prepare the solution, use food-grade sodium metabisulfite (SMBS). SMBS reacts with water to form sodium bisulfite (SBS) according to this reaction:

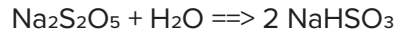

2. After soaking the elements for about 1 hour in the bisulfite solution, remove the elements and place them in a plastic oxygen barrier bag. Obtain oxygen barrier bags from Toray. Seal and label the bag(s), indicating the packaging date.
3. Storage conditions for used/repackaged elements are the same as for new RO elements. See page 1 of this section.
4. When sending back used elements to Toray, please contact Toray or its representative before unloading elements.

TMM-600 INTRODUCTION TO TROUBLESHOOTING

The RO system's potential problems can be recognized early by monitoring the changes of permeate flow rate*, salt passage (salt rejection)*, and differential pressure* of the RO pressure vessels. Therefore, it is recommended that the system operator(s) record and review operational data frequently. Early detection of system performance decline will alert the operators to potential operational problems and initiate appropriate countermeasures to restore membrane element performance.

Typical performance changes and their countermeasures are explained in section **TMM-610: Typical Performance Changes and Countermeasures**.

The basic steps of troubleshooting are summarized below:

Action	Item concerned
Check	Calibration of Instruments: Pressure, Temperature, Conductivity, pH, Flow etc.
Review	Daily operational data, normalized data, maintenance logs, and comparison of current performance to design specifications.
Investigate	Reasons for performance changes and their possible causes. Refer to TMM-610 Typical Performance Changes and Countermeasures.
Troubleshoot	Initiate corrective measures; perform countermeasures in a timely fashion e.g. chemical cleaning, sterilization, replacement of defective parts, system adjustments.

Permeate Center Pipe Probing Method

If measuring permeate conductivity from a specific pressure vessel indicates a sudden and significant increase in permeate conductivity, a faulty o-ring (mechanical leak) or loss of rejection in the membrane may cause the high salt passage. Probing the elements will help determine the cause of the increase in the salt passage. **Figures TMM-600-1 and TMM-600-2** shows the probing apparatus.

Water quality (conductivity) can be easily measured at different positions within the pressure vessel by sampling the water using the center pipe probing technique.

*) Normalization of values marked with * is required to understand the operation data properly. Procedures for normalization are described in section TMM-230: Operation Monitoring.

TMM-600

Section page
2 of 3

INTRODUCTION TO TROUBLESHOOTING

Recommended Piping Arrangement and Permeate Sampling Probe for Each Element in One Module

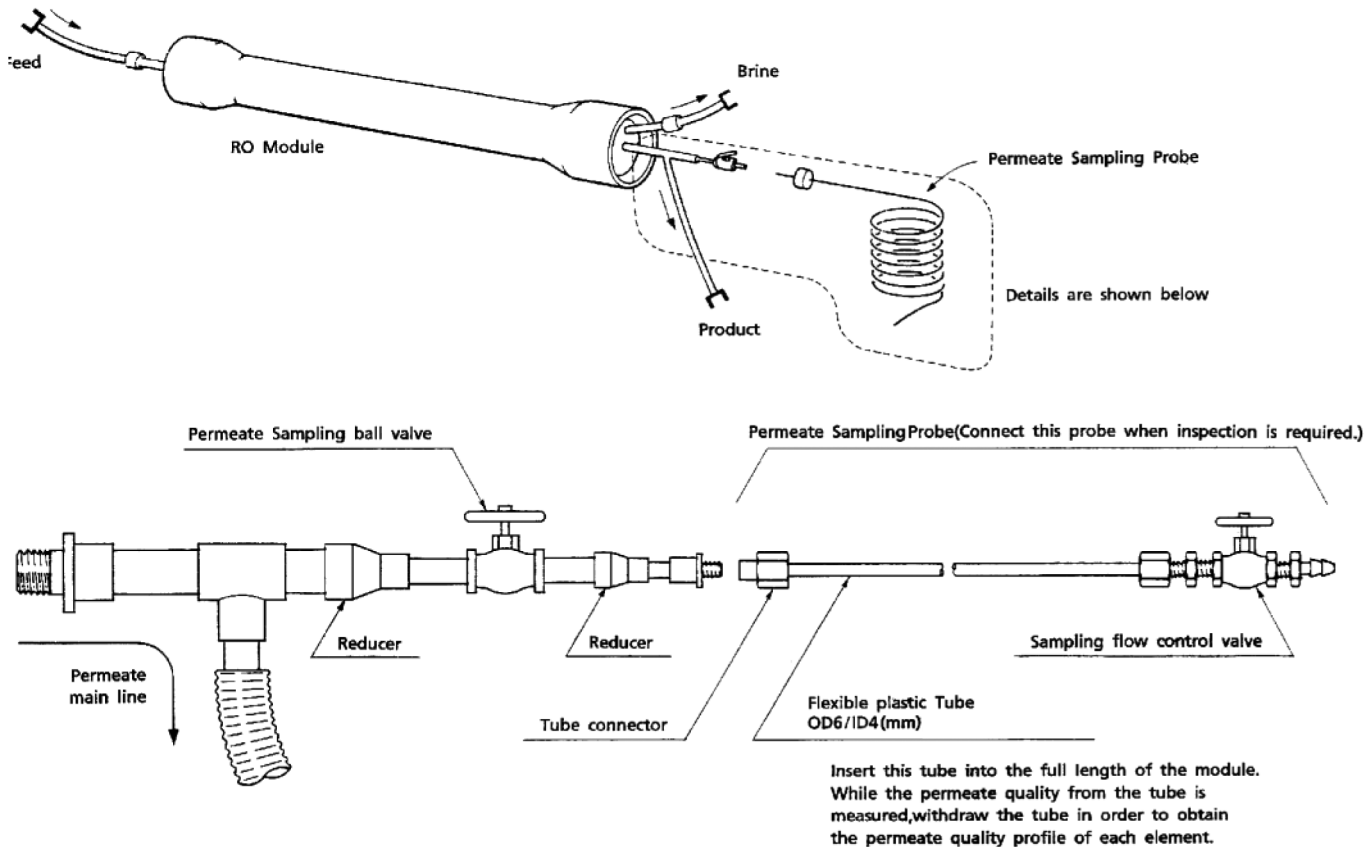

Figure TMM-600-1: Center pipe probing method 1

- Pressure Vessel Probing -

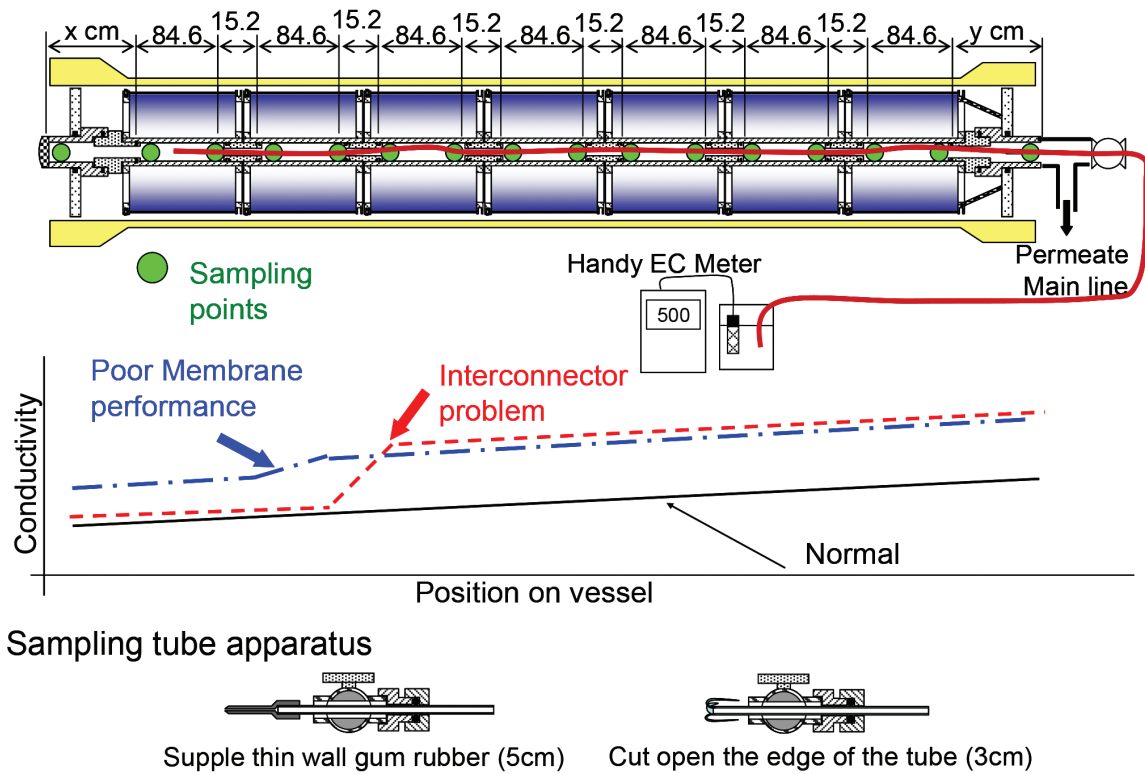

Figure TMM-600-2: Center pipe probing method 2

TMM-610Section page
1 of 8**TMM-610 TYPICAL PERFORMANCE CHANGES
AND COUNTERMEASURES**

Record reliable operational data daily to evaluate the performance of a RO system properly. Implement a regular instrument calibration to ensure the collected performance data is accurate. Logging of collected data and all maintenance procedures are important for proper system evaluation. Analysis of the recorded historical system data will help determine what remedy is best suited to recover any lost system performance.

This section is about problems and countermeasures regarding salt passage and permeate flow rate. Section **TMM-230: Operation Monitoring** discusses the impact of feed water conditions such as pressure, temperature, concentration, pH, and recovery ratio in the system performance.

The following abbreviations are used in this section:

NPFR	= Normalized permeate flow rate
NSP	= Normalized salt passage
DP	= Differential pressure

TYPICAL PERFORMANCE CHANGES AND COUNTERMEASURES

TMM-610

Section page
2 of 8

**Case A: Normalized Permeate Flow Rate (NPFR) Decline:
First Bank**

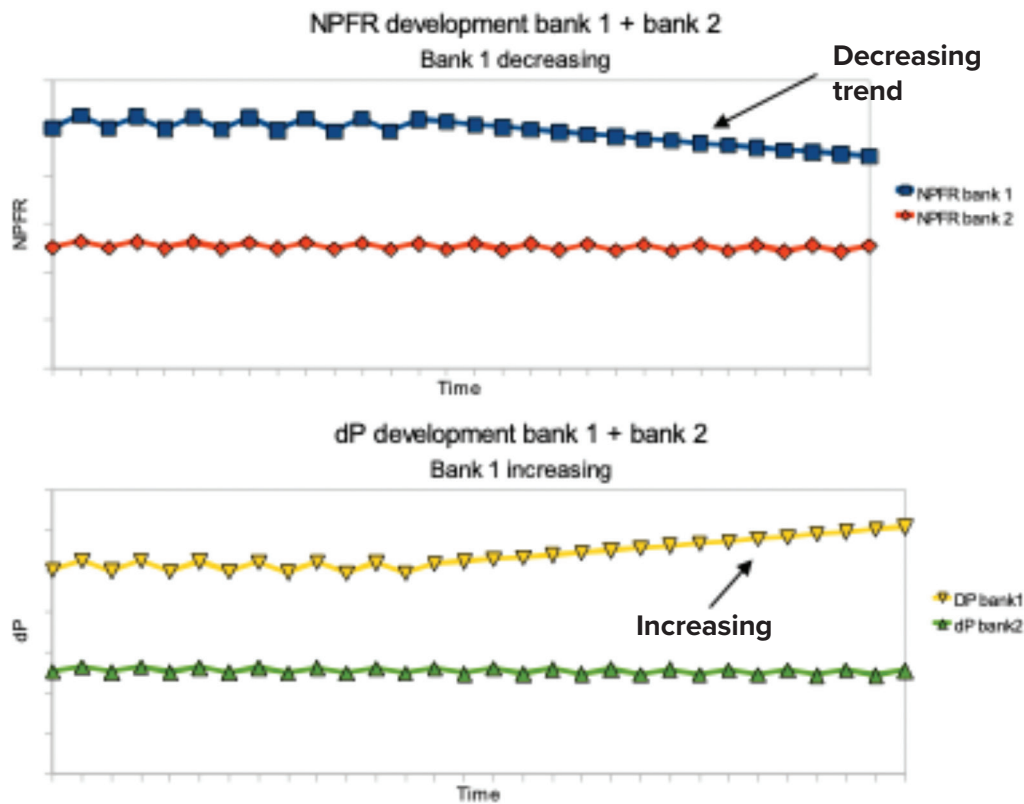

Potential causes

Countermeasures

Change in feed water quality

Check operating parameters (recovery, flux). Optimize pre-treatment, check pre-filtration (perform any required adjustments).

Fouling by metal hydroxides, inorganic colloids, organic or bacterial matter

Optimize pre-treatment, followed by appropriate CIP and / or sterilization.

Fouling by suspended particles

Chemical cleaning.
Optimize pre-treatment, check pre-filtration equipment.

TMM-610

Section page
3 of 8

TYPICAL PERFORMANCE CHANGES AND COUNTERMEASURES

Case B: Normalized Permeate Flow Rate (NPFR) Decline: Last Bank

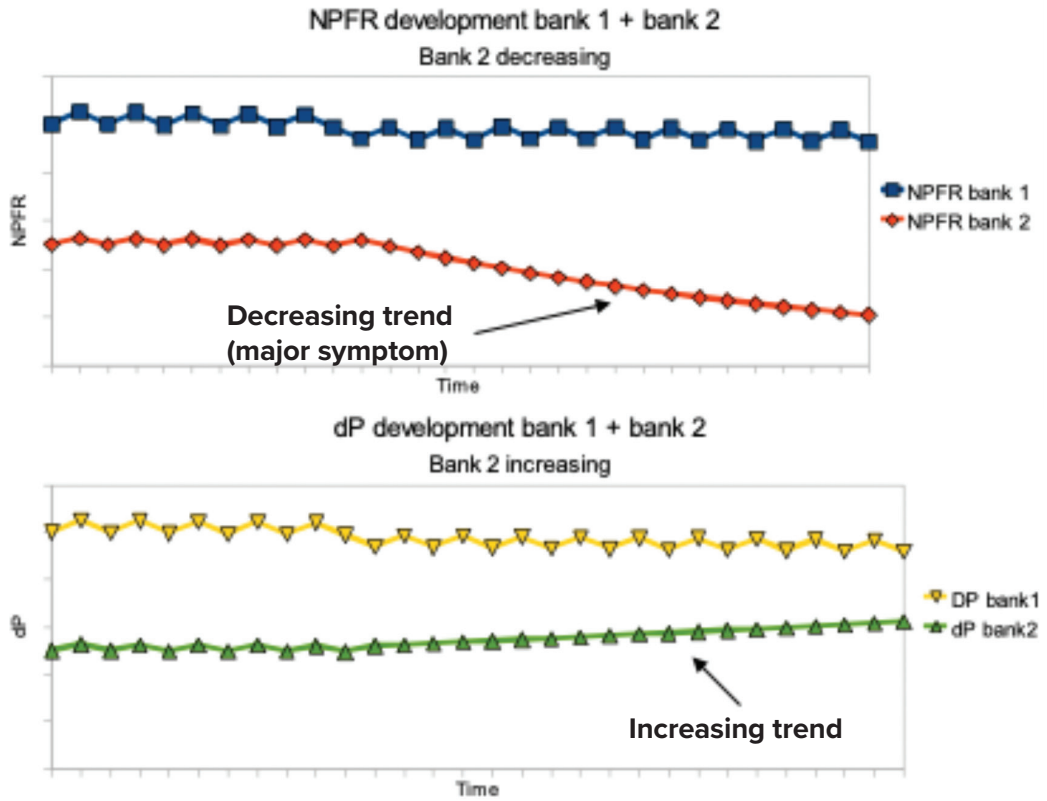

Potential causes

Countermeasures

Change in feed water quality	Check operating parameters (recovery, flux). Optimize pre-treatment, especially the scale inhibitor injection system and dosage rate.
Scaling in bank 2 (precipitation of sparingly soluble salts)	Check feed analysis for changes. Check scale inhibitor injection system and inhibitor dosage rate.
Fouling by metal hydroxides, inorganic colloids, organic or bacterial matter	Optimize pre-treatment, analyse the foulant followed by an appropriate CIP and / or sterilization procedure.
Fouling by suspended particles	Analyze precipitate, followed by appropriate chemical cleaning.

TYPICAL PERFORMANCE CHANGES AND COUNTERMEASURES

TMM-610

Section page
4 of 8

Case C: Normalized Salt Passage (NSP) Increase: All Vessels

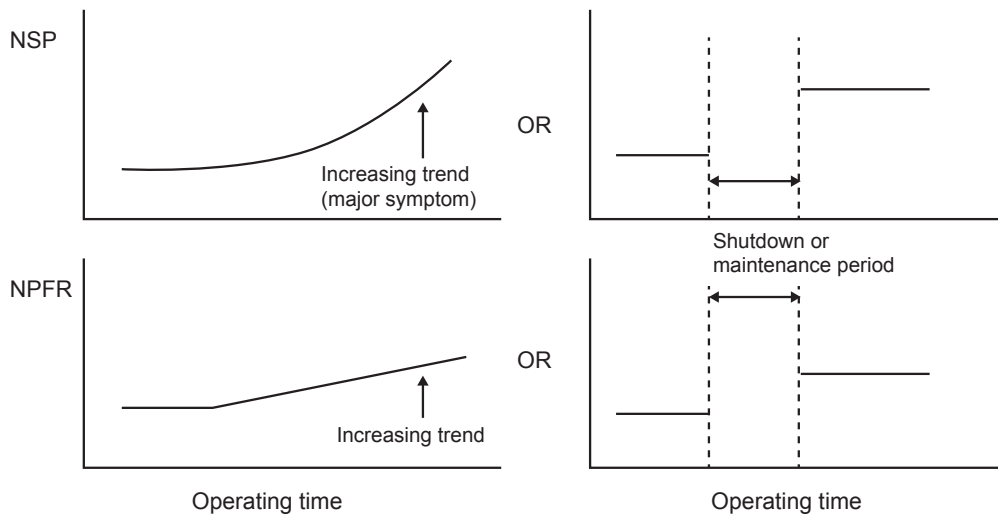

Potential causes

Countermeasures

Membrane affected by exposure to oxidants,
Use of non-compatible chemicals,
System operation outside recommended design values.

Check, modify and/or optimize chemicals that come in contact with the membrane elements.
Check oxidant removal apparatus (if any).
Check and adjust operating conditions according to recommendations of the membrane manufacturer.

Mechanical damage due to scratch by particles such as precipitation of sparingly soluble salts.

Check pre-treatment, in particular regarding pH adjustment and / or dosing rate of scale inhibitors.
Adjust system recovery with attention to limits given by feed water chemistry.

TMM-610

Section page
5 of 8

TYPICAL PERFORMANCE CHANGES AND COUNTERMEASURES

**Case D: Normalized Permeate Flow Rate (NPFR) Decrease:
All Banks Simultaneously**

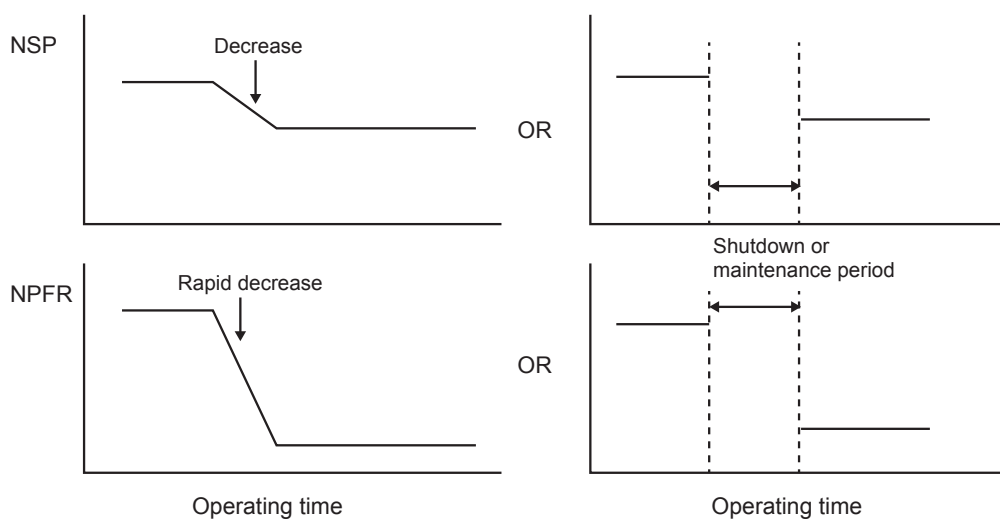

Potential causes

Initial stages of damage caused by exposure of non-compatible chemicals.

Countermeasures

Check, modify and/or optimize chemicals coming in contact with the membranes. Check to make sure all chemicals are compatible with the installed membrane.

Check and adjust operating conditions according to recommendations of the membrane manufacturer.

TYPICAL PERFORMANCE CHANGES AND COUNTERMEASURES

TMM-610

Section page
6 of 8

Case E: Normalized Permeate Flow Rate (NPFR) Decrease: All Banks Simultaneously with Variations for Individual Brine stages

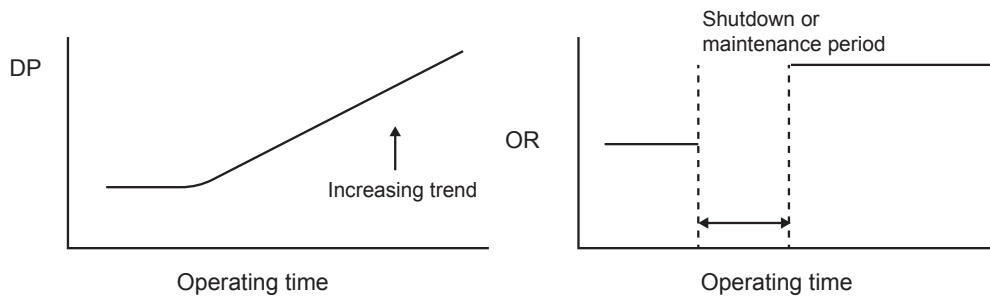

Potential causes

Countermeasures

Excessive concentration polarization

Check and adjust operating conditions according to recommend guidelines. Make sure the minimum brine flow requirement has been maintained. Check the system’s recovery rate to make sure it is within the system design specifications- if needed reduce the recovery.

Check pre-treatment chemical dosage and addition.

Check and replace brine seals if necessary.

TMM-610

Section page
7 of 8

TYPICAL PERFORMANCE CHANGES AND COUNTERMEASURES

Case F: Differential Pressure (DP) Increase

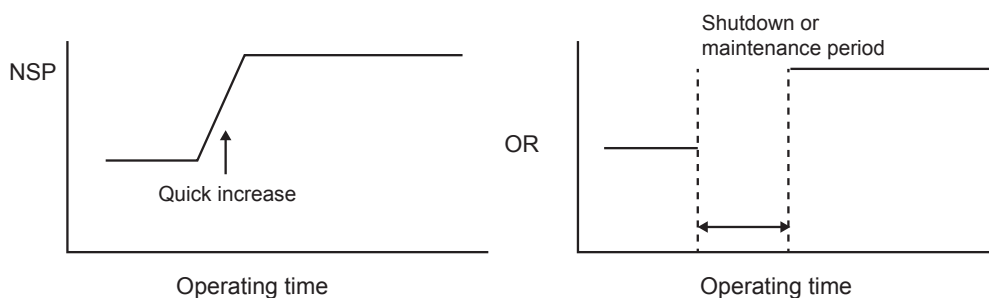

Potential causes

Contamination by particulate matter or bio-growth

Excessive feed flow

Countermeasures

Refer to Case A and B.

Check and improve pre-treatment, in particular for particle removal and carbon feed to system (TOC/DOC ratio).

Check feed flow rates for compliance with recommendations and latest trends.

TYPICAL PERFORMANCE CHANGES AND COUNTERMEASURES

TMM-610

Section page
8 of 8

**Case G: Normalized Salt Passage (NSP) Increase:
Individual Vessels**

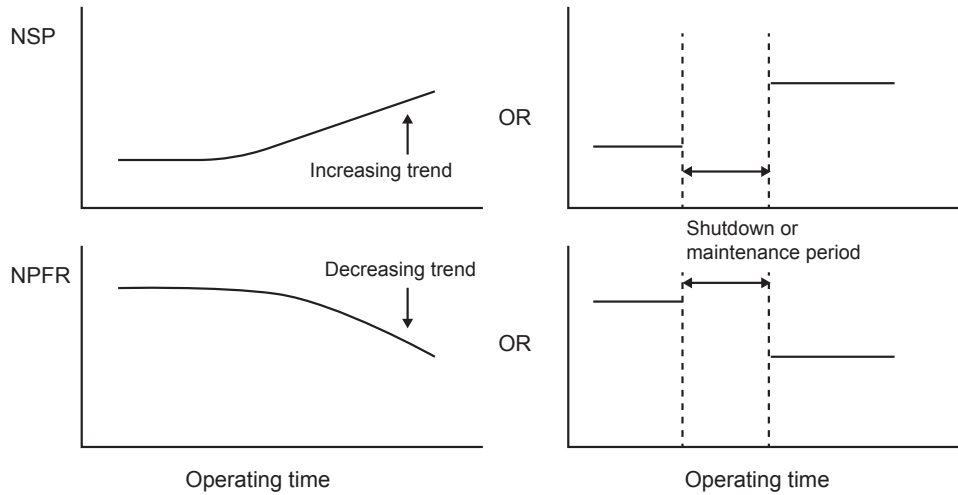

Potential causes

Countermeasures

- Mechanical leakage due to O-ring seal damage
- Excessive feed flow / pressure drop
- Excessive permeate backpressure

Detect location of the leak in a particular vessel by probing the pressure vessel in question.

Make sure permeate back pressure (permeate pressure minus feed/brine pressure) is less than 0.03 MPa [5 psi] at all times especially during start-up and shut down.

TMM-700

Section page
1 of 1

TMM-700 POLICY FOR CHEMICAL COMPATIBILITY TEST

1. Toray will not accept any compatibility test inquiries as it is not RO membrane manufacturer's scope.
2. Toray can provide information on the compatibility of RPI antiscalants to customers, as promoted by Toray.
3. Toray will disclose the recommended method for testing only as a reference for the compatibility of chemicals supplied by other chemical manufacturers. It is the customer's responsibility to make and draw their evaluations and conclusions. Toray does not take any responsibility for test results and findings made by customers.
4. Please contact Toray for the validity of the test results previously reported by Toray because compatibility will change due to the composition of chemicals or membrane specifications.



Toray specializes in the development and manufacture of innovative membrane technologies. We offer an integrated approach using our RO, NF, UF, MBR, and antiscalant products to solve water and process treatment challenges. Contact us today to find out how Toray can help maximize water recovery, achieve high water quality for water reuse, lower energy requirements, and minimize life cycle costs. **TORAY, experts in RO, NF, UF and MBR.**

www.water.toray

'TORAY'

Innovation by Chemistry