

# Karl Fischer Titration



GTP Brochure

## Good Titration Practice™ in Karl Fischer Titration

METTLER TOLEDO



## EDITORIAL

Dear Reader

METTLER TOLEDO has an excellent knowledge in any kind of moisture and water content determination from % to ppm. It is of crucial importance to select the right analytical method in order to obtain reliable results that ensure quality and properties of the products in a multitude of industries.

Karl Fischer titration is the method of choice for water content determination. With the new generation of METTLER TOLEDO compact volumetric and coulometric Karl Fischer Titrators V20/V30, C20/C30 and Excellence combined general and volumetric KF titrators T70 and T90, water determination has reached an unrivaled level of simplicity and security. This helps you to perform your daily tasks in the most optimal way.

In this brochure a specific focus is put on how to perform the Karl Fischer titration analysis the correct way. We would like to introduce this to you as part of 'Good Titration Practice<sup>™</sup> (GTP) in Karl Fischer titration. This brochure comprises detailed background information and recommendations about:

- Chemistry and control of the Karl Fischer titration
- Practical tips and hints on sample preparation and instrument operation
- Measures to optimize accuracy and precision of the water determination
- Selection of the optimal method for water determination of your specific sample
- Trouble shooting recommendations if results do not coincide with the expectations

This GTP brochure in combination with the application brochure 38 should serve you as powerful tools for trouble-free water determination throughout the whole lifetime of your METTLER TOLEDO KF titrator.

We wish you great success and enjoyment



Hans-Joachim Muhr  
Market Support Manager  
BA Titration



Rolf Rohner  
Marketing Manager  
BA Titration



# Contents

|       |   |    |
|-------|---|----|
| 1     | Fundamentals of the Karl Fischer titration .....  | 4  |
| 1.1   | An historic overview.....   | 4  |
| 1.2   | The Karl Fischer chemical reaction.....   | 5  |
| 1.3   | Consequences for practical applications.....  | 6  |
| 2     | Volumetric and Coulometric Karl Fischer Analyses .....  | 7  |
| 2.1   | Volumetric KF reagents .....  | 7  |
| 2.1.1 | One-component KF reagent.....   | 7  |
| 2.1.2 | Two-component KF reagent.....   | 8  |
| 2.1.3 | Pyridine-containing reagents.....   | 8  |
| 2.1.4 | Special reagents for aldehydes and ketones.....   | 8  |
| 2.1.5 | Karl Fischer reagents with ethanol .....  | 9  |
| 2.2   | Coulometric KF analysis .....   | 9  |
| 2.2.1 | KF coulometry.....  | 9  |
| 2.2.2 | Stoichiometry of the coulometric KF reaction .....  | 10 |
| 2.2.3 | Iodine generation .....   | 11 |
| 2.2.4 | Generator electrode without diaphragm .....   | 11 |
| 2.2.5 | Limitations for the use of the cell without diaphragm .....   | 12 |
| 3     | Titration control and end point determination.....  | 13 |
| 3.1   | Indication .....  | 13 |
| 3.1.1 | Principle of bipotentiometric indication .....  | 13 |
| 3.1.2 | End point and polarization current.....   | 14 |
| 3.2   | Reaction rate .....   | 16 |
| 3.3   | Stirring speed and dispersion of the volumetric KF titrant .....                                      | 16 |
| 3.4   | Control parameters in the volumetric KF titration .....   | 18 |
| 3.4.1 | The Control Band.....   | 18 |
| 3.4.2 | The minimum and maximum dosing rate .....   | 19 |
| 3.4.3 | The Cautious start.....   | 19 |
| 3.4.4 | Polarization current and end point.....   | 19 |
| 3.4.5 | Application tips.....   | 20 |
| 3.4.6 | General recommendations.....  | 21 |
| 3.5   | Control parameters in the coulometric KF Analysis.....  | 21 |
| 3.6   | Termination parameters for both coulometric and volumetric KF titration.....                          | 22 |
| 3.6.1 | Using and optimizing the termination parameters for both volumetric and coulometric KF titration..... | 24 |
| 4.    | The Karl Fischer titration .....  | 26 |
| 4.1   | The influence of atmospheric humidity (drift determination).....                                      | 26 |
| 4.1.1 | Titration stand.....  | 26 |
| 4.1.2 | The drift .....   | 27 |
| 4.2   | Working with the coulometric KF instruments.....  | 28 |
| 4.2.1 | Filling the coulometric cell.....   | 28 |
| 4.2.2 | When do you have to replace the electrolyte? .....  | 29 |
| 4.2.3 | Secure draining and filling of the titration cell: SOLVENT MANAGER.....                               | 29 |
| 4.2.4 | Cleaning the coulometric KF titration cell.....   | 32 |
| 4.2.5 | Cleaning the measuring electrode .....  | 33 |
| 4.3   | Volumetric KF Titration: Titrant concentration.....   | 33 |
| 4.3.1 | How often should the concentration be determined? .....   | 33 |
| 4.3.2 | Concentration determination with di-sodium tartrate dihydrate .....                                   | 34 |
| 4.3.3 | Concentration determination with Water Standard 10.0 mg/g .....                                       | 35 |
| 4.3.4 | Concentration determination with pure water.....  | 36 |
| 4.3.5 | The solvent.....  | 37 |
| 4.3.6 | Dissolving capacity of the solvent.....   | 38 |
| 5     | Sampling.....   | 39 |

|   |    |
|---|----|
| 5.1 Taking the sample .....                             | 39 |
| 5.2 Storing the sample .....                            | 39 |
| 5.3 Amount of sample .....                              | 40 |
| 6 Sample addition .....                                 | 43 |
| 6.1 Liquid samples .....                                | 43 |
| 6.2 Solid samples .....                                 | 45 |
| 7 Release of water from the sample .....                | 47 |
| 7.1 Internal extraction .....                           | 48 |
| 7.2 External extraction .....                           | 49 |
| 7.3 External dissolution .....                          | 54 |
| 7.4 Lyophilized substance in septum bottles .....       | 55 |
| 7.5 Determination of water in gases .....               | 57 |
| 7.6 Determination using the drying oven .....           | 58 |
| 7.6.1 Principle .....                                   | 58 |
| 7.6.2 Purge gas .....                                   | 58 |
| 7.6.3 Procedure .....                                   | 59 |
| 7.6.4 Manual Karl Fischer drying oven .....             | 60 |
| 7.6.5 STROMBOLI automatic oven sample changer .....     | 62 |
| 8 Measurement results .....                             | 67 |
| 8.1 Resolution and detection limit .....                | 67 |
| 8.2 Measurement accuracy .....                          | 67 |
| 8.3 Repeatability .....                                 | 68 |
| 9 Interferences .....                                   | 70 |
| 9.1 Effects of temperature .....                        | 70 |
| 9.2 Side reactions .....                                | 70 |
| 9.2.1 Reaction with methanol .....                      | 71 |
| 9.2.2 Reaction with water .....                         | 71 |
| 9.3 Reaction with iodine .....                          | 71 |
| 9.4 Example: reevaluation of side reactions .....       | 72 |
| 10 Troubleshooting .....                                | 73 |
| 10.1 Coulometry .....                                   | 73 |
| 10.2 Volumetric Karl Fischer Titration .....            | 75 |
| 11 Karl Fischer Titration: The Method at a Glance ..... | 77 |
| 11.1 Solid samples .....                                | 77 |
| 11.1.1 Organic Chemicals .....                          | 77 |
| 11.1.2 Inorganic chemicals .....                        | 78 |
| 11.1.3 Technical products – organic .....               | 78 |
| 11.1.4 Technical products - inorganic .....             | 79 |
| 11.1.5 Technical natural products .....                 | 79 |
| 11.1.6 Food .....                                       | 79 |
| 11.2 Liquid samples .....                               | 80 |
| 11.2.1 Organic and inorganic chemicals .....            | 80 |
| 11.2.2 Foods and technical products .....               | 81 |
| 11.3 Titration Methods .....                            | 83 |
| 11.3.1 Volumetric methods .....                         | 83 |
| 11.3.2 Coulometric methods .....                        | 85 |
| 11.4 Sample preparation and input .....                 | 86 |
| 11.4.1 Solids: Characteristics .....                    | 86 |
| 11.4.2 Solids: Sample input .....                       | 86 |
| 11.4.3 Liquids: Characteristics .....                   | 87 |
| 11.4.4 Liquids: Sample input .....                      | 87 |
| 11.4.5 Accessories for sample input .....               | 87 |
| 11.4.6 References .....                                 | 88 |
| 11.5 Additional literature .....                        | 89 |
| 12 Appendix .....                                       | 90 |

|   |    |
|---|----|
| 12.1 Formula for the external extraction .....                          | 90 |
| 12.2 Formula for the external dissolution.....                          | 91 |
| 12.3 Standards for Karl Fischer coulometry.....                         | 91 |
| 12.4 Reagents and solvents for coulometric analysis .....               | 92 |
| 12.4.1 For samples that are soluble in methanol or ethanol.....         | 92 |
| 12.4.2 For samples that are poorly soluble in methanol or ethanol ..... | 92 |
| 12.4.3 For samples that are insoluble in methanol or ethanol.....       | 93 |
| 12.4.4 For ketones and aldehydes .....                                  | 93 |
| 12.4.5 For acids and bases (pH value) .....                             | 94 |
| 12.5 Water Standards for Karl Fischer volumetric titration.....         | 95 |
| 12.6 Titrants and solvents for volumetric analysis .....                | 95 |
| 12.6.1 For samples soluble in methanol or ethanol.....                  | 95 |
| 12.6.2 For samples poorly soluble in methanol or ethanol .....          | 95 |
| 12.6.3 For samples insoluble in methanol or ethanol.....                | 96 |
| 12.6.4 For ketones and aldehydes .....                                  | 96 |
| 12.6.5 For acids and bases (pH value) .....                             | 97 |
| 13 Hazards and waste disposal tips .....                                | 98 |
| 13.1 One-component reagent.....   | 98 |
| 13.2 Two-component reagent:.....  | 98 |
| 13.3 Reagents for coulometry: .....                                     | 98 |
| 13.4 Safety data for the KF-components and auxiliary solvents: .....    | 98 |

# 1 Fundamentals of the Karl Fischer titration

## 1.1 An historic overview

- 1935 Publication: "Neues Verfahren zur massanalytischen Bestimmung des Wassergehaltes von Flüssigkeiten und festen Körpern" by Karl Fischer [1].
- 1943 Publication: "The Dead-Stop End Point", by G. Wernimont and F.J. Hopkinson [2].
- 1950 Pyridine-containing two-component reagents and dead-stop titration instruments are commercially available.
- 1952 Use of Karl Fischer method spreads, promoted by publications by E. Eberius [3].
- 1955 Publication on stabilized single-component Karl Fischer reagent by E. D. Peters and J. L. Jungnickel.
- 1956 First German DIN standard for the Karl Fischer titration (DIN 51777, April 1956, "Testing of mineral oil hydrocarbons and solvents: Determination of water content according to Karl Fischer - Direct method").
- 1959 Publication: Coulometric Karl Fischer Titration by A. S. Meyer and C. M. Boyd [4].
- 1960 Automatic KF titration instruments with piston motorized burettes. Enormous spread of the use of KF titration.
- 1970 First coulometric KF titration instruments are commercially available.
- 1980 Pyridine-free KF reagents are commercially available.
- 1984 First microprocessor controlled KF titrator (METTLER DL18) with automatic drift compensation, and solvent dispensing and removal.
- 1985 First fully automatic KF titration with laboratory robots (METTLER DL18 and ZYMARK); DO185 Drying Oven for the DL18 Karl Fischer Volumetric Titrator.
- 1989 First diaphragm-less cell for coulometric KF titration.
- 1990 DL37 KF Coulometer from METTLER TOLEDO.
- 1995 Water standards (10.0, 1.0, 0.1 mg/g) with test certificate according to DIN 50049-2.3  
First titrator (METTLER TOLEDO DL55) with online curves  $E = f(t)$  and  $V = f(t)$  for Karl Fischer titration.
- 1997 New DV705 KF Titration Stand with very low drift value ( $< 2\mu\text{g}/\text{min}$ ) for the METTLER TOLEDO DL53/55/58, and DL67/70ES/77 Titrators
- 1998 Introduction of the METTLER TOLEDO DL31/DL38 KF Titrators with dedicated fuzzy logic control, titrant specific standard parameters and LEARN titration. They replaced the DL18/35 KF Volumetric Titrators.  
Introduction of less poisonous KF reagents based on ethanolic solution.
- 2000 METTLER TOLEDO RONDO Sample Changer with Karl Fischer Kit for automated KF volumetric determination.
- 2001 Improved METTLER TOLEDO DO307 KF Manual Drying Oven.  
Solid KF Oven Standards with water contents of 5.5% and 1%, respectively.
- 2002 Introduction of the METTLER TOLEDO DL32/39 KF Coulometers (generating cell with and without diaphragm).  
Introduction of the METTLER TOLEDO STROMBOLI KF Oven Sample Changer.
- 2008 Introduction of the METTLER TOLEDO Titration Compact Line V20/V30 and C20/C30 Karl Fischer Instruments.



## 1.2 The Karl Fischer chemical reaction

The water content determination is based on the reaction described by R. W. Bunsen [5]:



Karl Fischer discovered that this reaction could be used for water determinations in a non-aqueous system containing an excess of sulfur dioxide [1]. Methanol proved to be suitable as a solvent. In order to achieve an equilibrium shift to the right, it is necessary to neutralize the acids that are formed during the process (HI and H<sub>2</sub>SO<sub>4</sub>). Karl Fischer used pyridine for this purpose. Smith, Bryanz and Mitchell [6] formulated a two-step reaction:

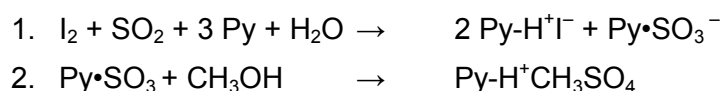

According to these equations, methanol not only acts as a solvent but also participates directly in the reaction itself. In an alcoholic solution, the reaction between iodine and water takes place in the stoichiometric ratio of 1:1. In an alcohol-free solution, the reaction between iodine and water takes place in the stoichiometric ratio of 1:2:

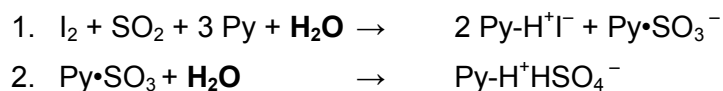

Further studies conducted by J. C. Verhoff and E. Barenrecht [7] on the subject of the Karl Fischer reaction have revealed that:

- Pyridine is not directly involved in the reaction, i.e., it only acts as a buffering agent and can therefore be replaced by other bases,
- The rate of the Karl Fischer reaction, described by the rate constant  $k$ , depends on the pH value of the medium (see graphics below)

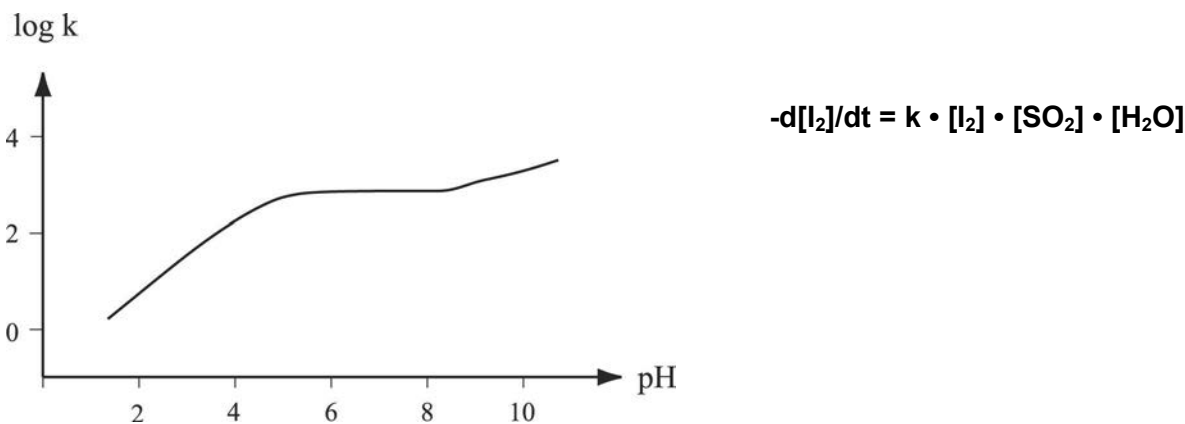

One possible explanation for the influence of pH on the reaction rate is that it is not the sulfur dioxide itself that is oxidized by iodine under the influence of water, but rather the methyl sulfite ion. This is formed from sulfur dioxide and methanol according to the equation:

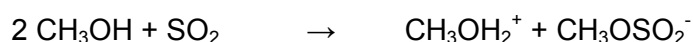

The higher the pH of the solution, the more methyl sulfite is formed by the capture of protons, and the faster the rate of the Karl Fischer reaction.

In the pH range 5.5 to 8, all the sulfur dioxide is present as methyl sulfite; the maximum reaction rate is reached here and cannot increase further. At pH values above 8.5, the

reaction rate increases due to side reactions between iodine and hydroxide or methylate ions; in a titration, this results in a more sluggish endpoint and higher iodine consumption.

On the basis of this knowledge, E. Scholz developed a pyridine-free Karl Fischer reagent with imidazole as base [8]. This reagent not only replaced the toxic, pungent pyridine, but also facilitated faster and more accurate titrations because imidazole buffers in a more favorable pH range than pyridine.

Studies by E. Scholz resulted in the following reaction scheme being proposed for the Karl Fischer reaction [8]:



This resulted in the general chemical equation:



E. Scholz was also able to confirm the existence of basic methylsulfite in methanol/SO<sub>2</sub>/I<sub>2</sub> solutions during the titration. In 1988, A. Seubert [9] identified methylsulfite in KF solutions with the aid of IR spectroscopy and isolated and identified methyl sulfate as the secondary product of the KF reaction.

Experiments on the stoichiometry of the reaction showed that methanol can in fact be replaced by other alcohols (e.g. ethanol, 2-propanol, methoxyethanol, diethylene glycol monoethylether) [10, and references therein]. This improves the titer stability.

### 1.3 Consequences for practical applications

- **Influence of pH on the Karl Fischer reaction**

Since the maximum rate of the Karl Fischer titration is in the pH range 5.5 to 8, pH values less than 4 and greater than 8 should be avoided in practice. With acidic or basic samples, you should adjust the pH value to the ideal range by adding buffering agents (for acids: imidazole, and for bases: salicylic acid).

- **Influence of the solvent on the Karl Fischer reaction**

The stoichiometry (molar ratio of H<sub>2</sub>O:I<sub>2</sub>) depends on the type of solvent:

Alcoholic solvent                      H<sub>2</sub>O:I<sub>2</sub> = 1:1                      (e.g. methanol)

Non-alcoholic solvent                H<sub>2</sub>O:I<sub>2</sub> = 2:1                      (e.g. dimethylformamide)

Studies by Eberius [3] showed that iodine and water react in the ratio of 1:1 if the percentage of methanol in the solvent is 20% or more. Methanol should therefore always be present in the minimum required amount. If a methanol-free titrant has to be used (e.g. for determination in ketones or aldehydes), you can use other alcohols such as, for instance, ethylene glycol monomethyl ether.

- **Influence of the water content of the sample on the Karl Fischer reaction**

The water content of the sample also influences the H<sub>2</sub>O:I<sub>2</sub> molar ratio. J.C. Verhoff and E. Barendrecht [7] observed an increase in the titer with water contents greater than 1 mol/L. This, however, is not a serious limitation because the water concentration in the solvent is usually much less.

## 2 Volumetric and Coulometric Karl Fischer Analyses

The determination of the water content according to Karl Fischer is nowadays performed by two different techniques:

- Volumetric Karl Fischer Titration, where a solution containing iodine is added using a motorized piston burette;
- Coulometric Karl Fischer Analysis, where iodine is generated by electrochemical oxidation in the cell

The selection of the appropriate technique is based on the estimated water content in the sample:



### Volumetric Karl Fischer Titration

Iodine is added by a burette during titration.  
Suitable for samples where water is present as a major component: **100 ppm - 100%**

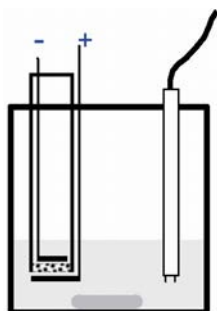

### Coulometric Karl Fischer Analysis

Iodine is generated electrochemically during titration.  
Suitable for samples where water is present in trace amounts: **1 ppm - 5%**

## 2.1 Volumetric KF reagents

### 2.1.1 One-component KF reagent

The **titrant** contains iodine, sulfur dioxide and imidazole, dissolved in a suitable alcohol. The **solvent** is methanol. You can also use a methanolic solvent mixture specially adapted to the sample as the solvent.

The reagent can be stored for approximately two years. The drop in titer, i.e., the decrease in concentration, is approximately 0.5 mg/mL per year in a sealed bottle. The reagent is available in three different concentrations:

5 mg/mL for samples with a water content of 1000 ppm to 100%,

2 mg/mL for samples with a water content of less than 1000 ppm,

1 mg/mL for samples with a water content of less than 200 ppm.

### 2.1.2 Two-component KF reagent

The **titrant** contains iodine and methanol. The **solvent** contains sulfur dioxide, imidazole and methanol.

A titration speed two or three times as high can be achieved with the two-component reagent. Both the components are very stable in storage. The titrant has a stable titer, provided that the bottle is tightly sealed. It is available in two different concentrations:

- 5 mg/mL for samples with a water content of 1000 ppm to 100%,
- 2 mg/mL for samples with a water content of less than 1000 ppm.

| Reagents      | +                                   | -  |
|---------------|-------------------------------------|--|
| One-component | Simple handling, favorably priced.  | Titer less stable, titration speed slower. |
| Two-component | High titration speed, stable titer. | Solvent capacity restricted.               |

### 2.1.3 Pyridine-containing reagents

Despite the existence of pyridine-free reagents, which allow for fast and accurate Karl Fischer titrations, reagents containing pyridine are still used because they are cheaper and can be made in-house.

*One-component reagent:*

The titrant contains iodine, sulfur dioxide and pyridine, dissolved in methanol. The solvent is either methanol or consists of methanol mixtures. Some manufacturers have slightly increased the pyridine content in the titrant to achieve a higher titration speed. This reagent is declared as “rapid”. To improve stability, some manufacturers also sell the titrant separated into solution A (sulfur dioxide, pyridine, methanol) and B (iodine, methanol). These solutions are mixed 1:1 just before use to form the one-component titrant.

*Two-component reagent:*

The titrant contains iodine dissolved in an alcohol, e.g. methanol, whereas the solvent consists of sulfur dioxide and a base, e.g. imidazole, dissolved in an alcohol (usually methanol), or an alcoholic mixture. The separation into titrant and solvent improves stability of the KF reagents, increases their lifetime, and results in higher titration speed.

### 2.1.4 Special reagents for aldehydes and ketones

Aldehydes (R-CHO) and ketones (R-CO-R) form acetals and ketals if titrated with standard methanol-containing reagents. As a result, additional water is produced and titrated at the same time, leading to higher water contents and a vanishing end point. Special methanol-free KF one-component reagents such as e.g. HYDRANAL® (Composite 5K and Working Medium K, from Sigma-Aldrich) and e.g. *apura*® (CombiTitrant 5 Keto with CombiSolvent Keto, from VWR/MERCK) are commercially available to prevent this problem.

*One-component reagent:*

The titrant contains iodine, imidazole, sulfur dioxide and 2-methoxyethanol, whereas the solvent contains 2-chloroethanol and trichloromethane. The titration takes slightly longer than with the standard KF reagent. Note that it may be necessary to adapt the end point value in the titration method to these reagents. This special reagent is also suitable for substances that react with methanol, such as amines.

### 2.1.5 Karl Fischer reagents with ethanol

Since ethanol is less toxic than methanol, two-component, ethanol-based reagents were launched in 1998. These reagents also allow for titration of several ketones which form ketals considerably more slowly in ethanol than in methanol.

The titrant contains iodine and ethanol, whereas the solvent contains sulfur dioxide, imidazole, diethanolamine and ethanol.

## 2.2 Coulometric KF analysis

### 2.2.1 KF coulometry

Coulometric KF determination of water is based on the standard reaction equation for the KF reaction.

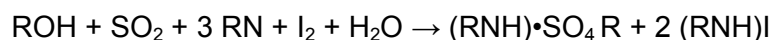

In coulometry, however, the iodine is generated electrochemically by anodic oxidation in the coulometric cell according to the following half-reaction:

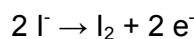

Iodine generation occurs at a generator electrode\* (also called "generator cell", or "inner burette") incorporated into the glass titration cell. The generator is close to the measuring electrode\*, a double pin platinum electrode, which is monitoring the potential of the sample solution by voltametric technique during coulometric titration.

The classical coulometric cell consists of two parts, the anode compartment and the cathode compartment. Both parts are separated by a diaphragm.

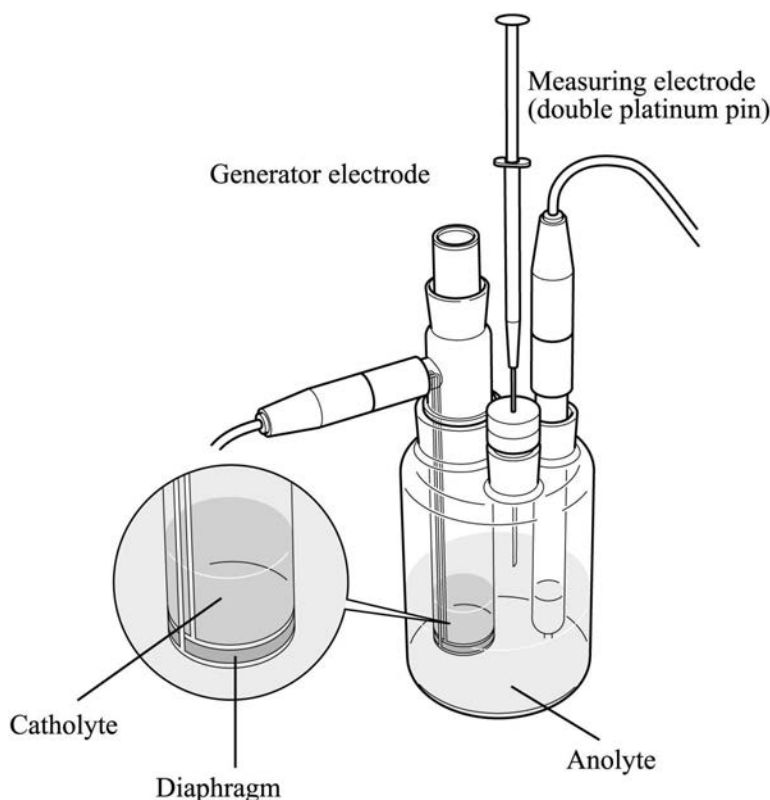

\* The terms "generator electrode" and "measuring electrode" mean an arrangement of two electrodes (anode and cathode) to form an electrolytic cell.

The anode compartment contains the anolyte, i.e. the KF electrolyte which is required for the oxidation in order to generate iodine by applying a current at the generating electrode. This consists of sulfur dioxide, imidazole and iodide salts. Methanol or ethanol is used as solvent. Depending on the application, other solvents such e.g. as chloroform, octanol, hexanol or ethylene glycol may be added.

The cathode compartment contains the catholyte, i.e. the reagent that enables completion of the whole electrochemical reaction: the oxidation reaction in the anolyte compartment is completed by a reduction reaction in the catholyte compartment. The catholyte is either a manufacturer-specific special reagent, or the same reagent as used in the anode compartment.

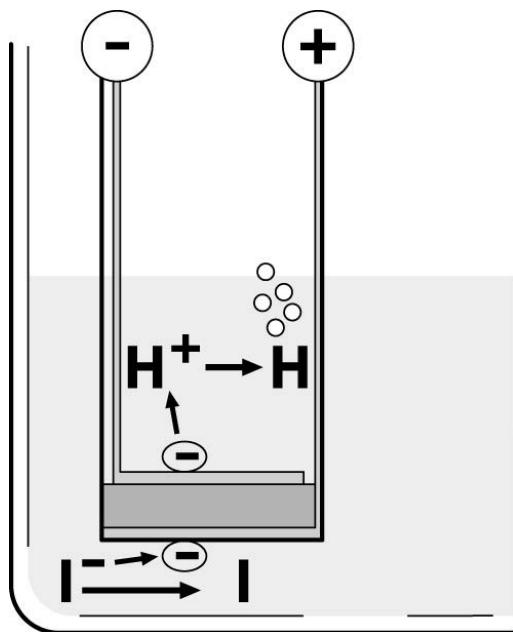

### Anode reaction

At the anode, iodine is generated from iodide by electrochemical oxidation. The negative iodide ions release electrons at the anode and form iodine, which subsequently reacts with water.

### Cathode reaction

At the cathode, the positive hydrogen ions are reduced to hydrogen. This is the main product formed.

An ammonium salt is added to the catholyte in order to promote hydrogen production.

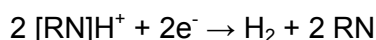

Ammonium ions are then reduced with the formation of hydrogen and a free amine.

Note that methyl sulfonic acid,  $\text{CH}_3\text{SO}_3\text{H}$ , present in the anolyte compartment, can reach the cathode where it is reduced to a sulfide compound (obnoxious smell!). This can cause the cathode to become black.

To avoid this, the catholyte should be replaced once in two weeks.

## 2.2.2 Stoichiometry of the coulometric KF reaction

The amount of water titrated by coulometric technique is determined by the amount of electrical current given in Coulomb, C, used to generate iodine. To calculate it, it is necessary to first recall the definition of 1 Coulomb: one coulomb, C, is the quantity of charge that is transported by a current of 1 ampere in one second.

$$1 \text{ C} = 1 \text{ A} \cdot 1 \text{ s}$$

On the other hand, it is known that to produce **one** mole of a chemical substance that requires **one** electron, 96485 C of current are needed. The value 96485 C/mol is known as the Faraday constant.

In Karl Fischer reaction **two** iodide ions,  $\text{I}^-$ , are oxidized to **one** molecule of iodine,  $\text{I}_2$ , releasing **two** electrons at the anode. Subsequently, iodine reacts with water.

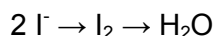

Therefore,  $2 \times 96485 \text{ C/mol}$  is required for 1 mole of water. Since the molar mass of water is  $18.015 \text{ g/mol}$ , this calculation can be expressed as follows:

**1 mg of water** corresponds to a consumption of **10.712 C** electrical current.

For an electrochemically optimized Karl Fischer cell, the current conversion efficiency for iodine production is assumed to be 100%.

Since current and time can be accurately measured, no standardization of the coulometric KF reagents is necessary. For this reason, coulometry is designated as absolute method. As a consequence, it is used as a reference method for the determination of water content.

Nevertheless, it is strongly recommended that the coulometer is regularly checked by measuring a certified water standard.

### 2.2.3 Iodine generation

Iodine is generated by means of current pulses of 400, 300, 200 and 100 mA. The rate of iodine generation is adjusted by varying the pulse duration and frequency and the pulse height (in mA). The maximum pulse height depends on the following factors:

- conductivity of the anolyte
- voltage at the generator electrode
- surface of the generator electrode

The voltage at the generator electrode and the surface of the electrode depend on the type of coulometer. In addition, the conductivity of the anolyte is influenced by the samples and additional solvents (chloroform, hexanol, etc.).

With standard conductivity values, the coulometer operates with current pulses of 400 mA. This gives an iodine generation rate which corresponds to a maximum of  $2240 \mu\text{g water/min}$ .

At very low conductivities (i.e. less than  $3\text{--}4 \mu\text{S/cm}$ ), the maximum possible current applied by the instrument is 100 mA.

### 2.2.4 Generator electrode without diaphragm

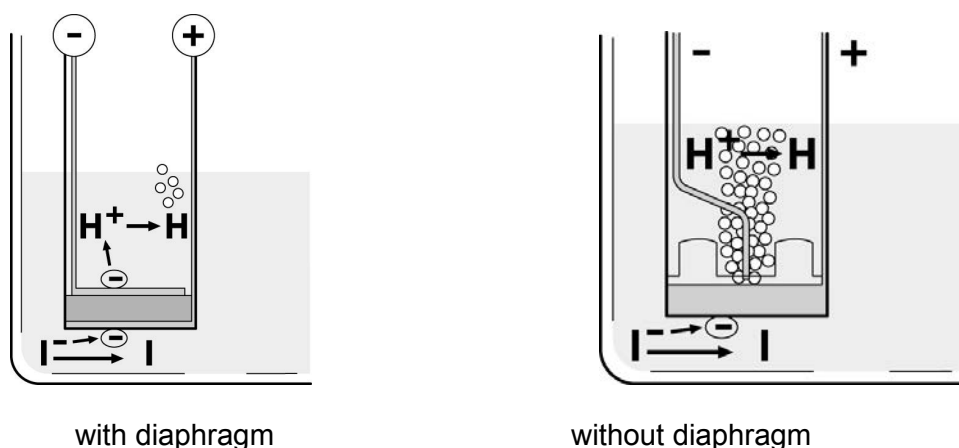

The first commercially available diaphragmless cell for KF coulometry was introduced in 1989. The main advantages compared to cells with diaphragms are:

- no contamination or blockage of the diaphragm
- easier cleaning
- lower drift

Originally, the generator cell was first built with a porous ceramic frit (diaphragm) separating the inner cathode compartment from the anode compartment. The purpose is to prevent that iodine molecules generated at the anode are immediately reduced to iodide ions at the cathode instead of reacting with water.

To avoid this concurring reaction, a different geometry is used for the generating cell *without* diaphragm. The cathode is smaller and made in such a way that iodine cannot reach the cathode (i.e. the cathode is a small-size pin). In addition, a relatively high stirrer speed allows for more rapid distribution of the generated iodine molecules. The latter can thus react more efficiently with water.

Note that hydrogen gas generated at the cathode is forming gas bubbles around its surface. Thus, this makes it almost impossible for iodine to reach the cathode and be reduced to iodide. This effect is further enhanced by the small dimensions of the cathode.

Nevertheless, it is still possible for a very small amount of iodine to reach the cathode. However, the relative error due to this effect can be minimized by using a larger amount of sample.

In practice, for measurement of samples having a very low water content (e.g., lower than 50 µg water/sample), and for very accurate determinations, the cell with diaphragm may yield more precise results.

### 2.2.5 Limitations for the use of the cell without diaphragm

The cell without diaphragm is not suitable for samples that are easily reduced. Nascent hydrogen is formed at the cathode. This is a very good reducing agent, especially for nitro compounds such as nitrobenzene.

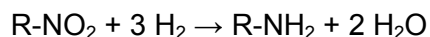

Besides this, other easily reducible substances such as unsaturated fatty acids, etc. may also be reduced at the cathode by the formation of water.

The diaphragmless cell is ideal for the determination of the water content of the following compounds:

- hydrocarbons - chlorinated hydrocarbons
- alcohols - phenols (most)
- esters - ethers
- ketones (with special reagent) - acetamides
- etheric oils and essences - edible oils
- petroleum oils

A cell with diaphragm is required for:

- samples with a very low water content (< 50 µg water/sample)
- very accurate determinations
- nitro compounds
- unsaturated hydrocarbons, especially when easily reducible.



### 3 Titration control and end point determination

The addition or generation of iodine must be controlled. Ideally, iodine should be added or generated as quickly as possible, and the addition or production stopped exactly at the end point. Only then can the titrant consumption or the generated iodine amount be determined with the desired accuracy, and hence, the water content.

The control of the titration is only possible if the end point is indicated. The resulting titration speed depends on the following factors:

- the addition speed or generation rate of iodine
- the reaction rate of the Karl Fischer reaction
- the stirring speed and mixing of the sample solution,
- the viscosity of the solution and its temperature,
- the control algorithm and its parameters,
- the termination of the analysis.

#### 3.1 Indication

##### 3.1.1 Principle of bipotentiometric indication

A bipotentiometric indication is used for the volumetric Karl Fischer titration as well as for the coulometric analysis (in electrochemical terminology this is also called "2-electrode potentiometry"). A small, constant AC current – the polarization current " $I_{pol}$ " – is applied to a double pin platinum electrode.

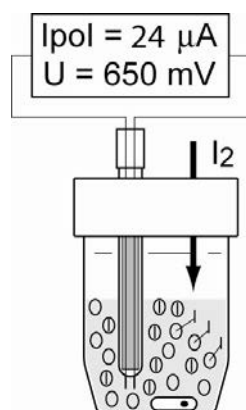

- As long as the added iodine reacts with the water, there is no free iodine in the titration/analyte solution.
- A high voltage is necessary to maintain the specified polarization current at the electrode.

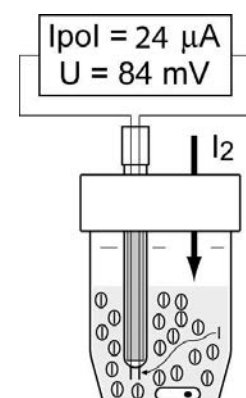

- As soon as all the water has reacted with iodine, there will be free iodine in the titration solution.
- Free iodine causes ionic conduction and the voltage needs to be reduced to keep the polarization current constant.
- When the voltage drops below a defined value, the titration is terminated.

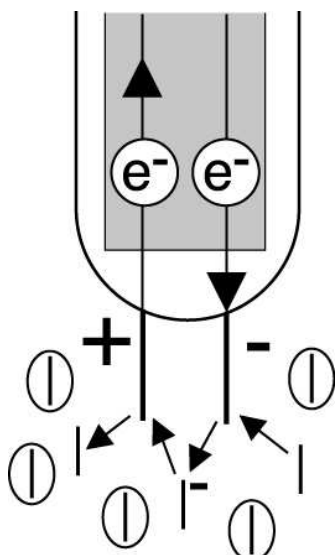

- The ionic conduction takes the following course: an iodine molecule is attracted by the negatively charged platinum pin.
- It then acquires two electrons and turns into iodide ions ( $2 \text{I}^-$ ).
- The two negatively charged iodide ions are attracted by the positively charged platinum pin, where they donate the electrons and form an iodine molecule,  $\text{I}_2$ , again.

#### At the beginning and during the titration:

As long as the iodine generated reacts with the water, there is no free iodine in the titration/analyte solution. A voltage of ca. 400 mV to 650 mV is necessary to maintain the set polarization current at the double pin electrode.

#### At the end of the titration:

As soon as all the water in the sample has reacted with the iodine, free iodine is present in the titration/analyte solution. This free iodine gives rise to "ionic conduction". Now a low voltage of 50 mV to 100 mV is required to keep the polarization current constant. This drop in voltage is used to indicate the end of the titration.

#### Ionic conduction

Iodine takes up an electron at the negatively charged platinum pin of the indicator electrode and is thereby reduced to iodide ( $\text{I}^-$ ). Iodide ions, which are present in excess in the titration solution, then release the electron again at the positively charged platinum pin and is again oxidized to iodine.

Thorough mixing of the titration/analyte solution is necessary in order to achieve constant "ionic conduction". The iodine is present only at low concentration. If mixing is poor, no iodine reaches the negatively charged platinum pin. This leads to a termination of "ionic conduction" and the measurement signal becomes unstable.

### 3.1.2 End point and polarization current

The Karl Fischer titration is terminated when an excess of iodine is detected in the titration cell, i.e. the titration end point is reached if the potential at the polarized platinum double pin electrode drops below a specific predefined value.

The end point value mainly depends on

- the polarization current,  $I_{\text{pol}}$ ,
- (to a lesser extent) the type of electrode (i.e. geometry and dimensions of the metal parts)
- the solvent or analyte used in the instrument, respectively.

Above all, this value depends on the polarization current.

For the **volumetric KF titration**, the following end points have been defined for methanolic **one-component and two-component** KF reagents using a V20/V30 volumetric KF titrator or T70/T90 Excellence titrator (double pin platinum electrode, pin length: 3 to 4 mm, pin diameter: 1 mm):

| AC Polarization current / $\mu\text{A}$ | Endpoint / mV |
|---|---------------|
| 24                                      | 100           |

For the **coulometric KF analysis**, the following values have been obtained with a C20/C30 KF Coulometer (double pin platinum sensor; pin length: 3 - 4 mm, pin diameter: 1 mm):

| AC Polarization current / $\mu\text{A}$ | Endpoint / mV |
|---|---------------|
| 5                                       | 100           |

The same end point values can be used for ethanol based KF coulometric reagents.

#### Which polarization current should be used?

A *higher* polarization current requires a larger iodine excess (indicated by a pronounced yellow coloration of the titration cell solution) to achieve ionic conduction for the determination of the end point. However, iodine excess should be as low as possible to get accurate results. As a consequence, the polarization current should be set as low as possible.

On the other hand, a *lower* polarization current gives a *smaller* and *steeper* potential jump at the end of the titration. This makes it more difficult to stop the titration at the right moment, i.e. just after the equivalence point, and increases the risk of over titration.

#### Influence of the sensor

The potential jump at the end of the titration is also influenced by the geometry (surface and design) of the platinum sensing material of the sensor. Sensors with a large platinum surface, e.g. with longer pins, a double ring or plates instead of rings, exhibit a smaller potential jump. In general the larger the platinum surface the smaller the current density. The current density can be compared to a water pipe where a specific water has to flow. The larger the diameter of the pipe, the lower the pressure needed to transport the desired amount of water through the pipe (= smaller pressure difference). Sensors with short platinum pins (< 3 mm), on the other hand, exhibit a larger potential jump and also a higher end point.

#### The condition of the sensor has an influence on the potential jump

Platinum is a strongly adsorbing metal, i.e. its surface can easily bond suitable chemical compounds. With use, a layer is formed on the surface of the platinum pin sensor, and increases the sensor resistance. With used sensors, this leads to a larger potential jump compared to a cleaned or a new sensor (without layer). The layer is formed during the first ten titrations, and subsequently it remains constant.

### 3.2 Reaction rate

The reaction rate of the Karl Fischer titration depends on:

- the water concentration, [H<sub>2</sub>O]
- the sulfur dioxide concentration, [SO<sub>2</sub>]
- and on the iodine concentration, [I<sub>2</sub>]

$$- d[I_2] / dt = k \cdot [I_2] \cdot [SO_2] \cdot [H_2O]$$

In addition, the pH value of the solution has a strong influence on the rate and in particular on the stoichiometry of the Karl Fischer reaction.

At the beginning, the water content is high, which gives a high reaction rate. Iodine generation or addition can proceed rapidly because iodine immediately reacts with water. Towards the end of the titration, the water concentration is lower, and the reaction rate also decreases: iodine must be generated or added more slowly because a small water amount is still present. Iodine generation or addition is usually the rate determining factor.

In the **volumetric KF titration**, note that sulfur dioxide is added only in *slight* excess with the iodine titrant solution when using one component titrant. On the other hand, with the two-component reagents, a large excess of sulfur dioxide is present in the solvent.

This results in a reaction rate up to 2 times *faster* for the two component reagent than for the one component reagent. Karl Fischer titrations with the two component reagent are thus significantly faster than with the one component reagent.

Example (V20/V30/T70/T90):

|                       |  |
|-----------------------|--|
| One-component reagent | 2-3 min with a titrant consumption of 2.0 mL     |
| Two-component reagent | 1.5 - 2 min with a titrant consumption of 2.0 mL |

In the **coulometric KF analysis**, sulfur dioxide is present in *large excess* in the anolyte. It is consumed with each additional measured sample leading to a decreasing dioxide concentration. As a consequence, *lower* reaction rates are achieved with anolyte solutions that have been used for a long time.

### 3.3 Stirring speed and dispersion of the volumetric KF titrant

Good mixing is essential for fast and accurate KF titrations. Mixing is influenced by the

1. stirring speed,
2. point of titrant addition (volumetric KF titration),
3. shape of the vessel (volumetric KF titration).

#### Stirring speed

The optimum stirring speed is obtained when a distinct vortex is visible. If the speed is too slow, the titration may also be too slow, irregular, and overtitration may occur. If

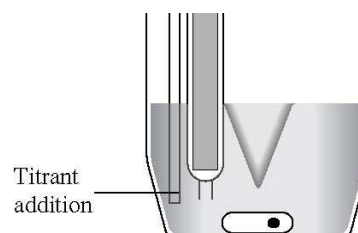

bubbles form into the solution, the stirring speed is too fast. Bubbles falsify the measured values.

### Point of titrant addition

The titrant should be added where the turbulence is the greatest to ensure efficient mixing. Furthermore, the point of addition should be sufficiently far away from the sensor to allow for sufficient time for reaction. Otherwise the sensor may directly detect added iodine, leading to slower addition and longer titration time.

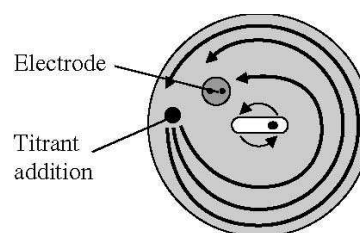

### Vessel shape

The conical shape of the beaker and the short stirring bar lead to turbulence at the point of titrant addition that effectively disperses the titrant. This is essential for a fast reaction rate and for short titration times.

If a longer stirring bar is used, turbulence is not achieved and the mixing effectiveness is lower. Iodine would not be distributed upwards, but rather along the base directly towards the sensor.

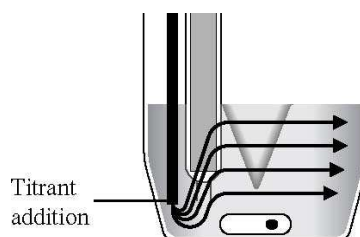

### 3.4 Control parameters in the volumetric KF titration

Several parameters can be defined in the titration method in order to optimize the method for the samples and the reagents. An overview of the control parameters is given as follows:

#### Volumetric KF Titration

| Control   |           | Tasks |
|---|-----------|-------|
| Methods » Method » Titration (KF Vol) » Control |           |       |
| End point                                       | 100.0 mV  | 1 2 3 |
| Control band                                    | 400.0 mV  | 1 2 3 |
| Dosing rate (max)                               | 5 mL/min  | 1 2 3 |
| Dosing rate (min)                               | 80 µL/min | 1 2 3 |
| Start   | Normal    | ▼     |
| Cancel  |           | OK    |

**End point**  
**Control band**  
**Dosing rate (max)**  
**Dosing rate (min)**  
**Start: Normal, Cautious**

The volumetric KF methods of the V20/V30 as well as T70 and T90 use KF titrant specific titration control parameters. The recommended standard values are listed in the following table:

| Recommended standard values  | 1-Comp titrant | 2-Comp titrant |
|------------------------------|----------------|----------------|
| Sensor I <sub>pol</sub> [µA] | 24             | 24             |
| Stirrer speed [%]            | 35             | 35             |
| End point [mV]               | 100            | 100            |
| Control band [mV]            | 400            | 400            |
| Dosing rate (min) [µL/min]   | 80             | 100            |
| Dosing rate (max) [mL/min]   | 5              | 3              |
| Start                        | normal         | normal         |
| Driftstop relative [µg/min]  | 15             | 15             |

#### 3.4.1 The Control Band

The control band is a modifiable control parameter for both types of KF reagents. The dynamic behaviour of the control can be influenced by a variation of the control band. The following drawing reveals a schematical illustration of the control band:

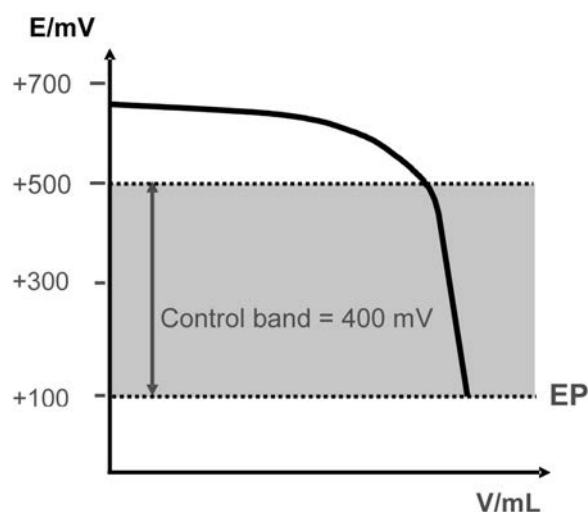

The titrant addition is calculated on one hand by using the distance of the actual potential from the end point and on the other by using  $dE/dt$ . The closer the potential to the end point, the slower is the titrant addition. Thus, if the control band width is decreased, the control reacts more sensitively to potential changes, which leads to a stronger reduction of the dosing speed. The dynamics of the control can be influenced in the following way:

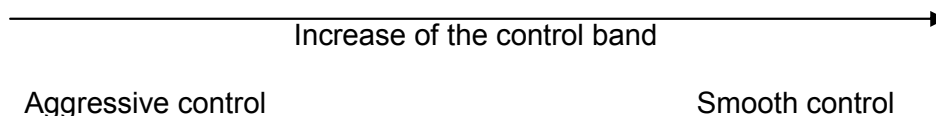

Two different controls are used for 1-Comp and 2-Comp titrants. The 2-Comp titrant control reacts more sensitively to a potential drop than the 1-Comp titrant control.

### 3.4.2 The minimum and maximum dosing rate

Both rates limit the dosing speed of the titrant to an upper or lower level. The maximum dosing rate is dependent on the actual burette size.

| Burette size [mL] | Maximum dosing rate [mL/min] |
|-------------------|------------------------------|
| 1                 | 3                            |
| 5                 | 15                           |
| 10                | 30                           |
| 20                | 60                           |

**Remark:** Since the maximum dosing rate of a 1 mL burette is lower than the standard parameter 5 mL/min in the case of a 1-Comp titrant, the titrator automatically issues a warning.

### 3.4.3 The Cautious start

If the water content is very low, the titration starts so quickly that overtitration may occur. In this case you can activate the Start: Cautious parameter. In the cautious mode, the titration starts with a slower acceleration (ramp up) than in the normal mode. This is more suited for small water amounts. In both cases (normal and cautious mode) the maximum dosing rate will be reached at the end of the ramping up, at higher water contents.

Recommendations

1. You should select **Start: Cautious** for one and two component reagents if the amount of water in the sample is less than 500 µg.
2. You can also set the maximum dosing rate to a lower value for small amounts of water if you wish the titration to progress more cautiously, e.g. Dosing rate (max) = 2 mL/min. With large amounts of water, however, the titration will take too long.

### 3.4.4 Polarization current and end point

Each end point is valid for a specific polarization current, i.e., if the polarization current changes, the end point must be adjusted.

The end point for a specific polarization current is influenced by the sensor and the solvent. In particular, longer titration times and poorer repeatability are resulting by selecting a higher end point potential value. The following points represent possible contributing factors:

- contaminated or old sensors,
- sensors with very short platinum pins (< 3 mm),

- long alkyl chain alcohols, e.g. 2-propanol, used as solvent, instead of methanol or ethanol.

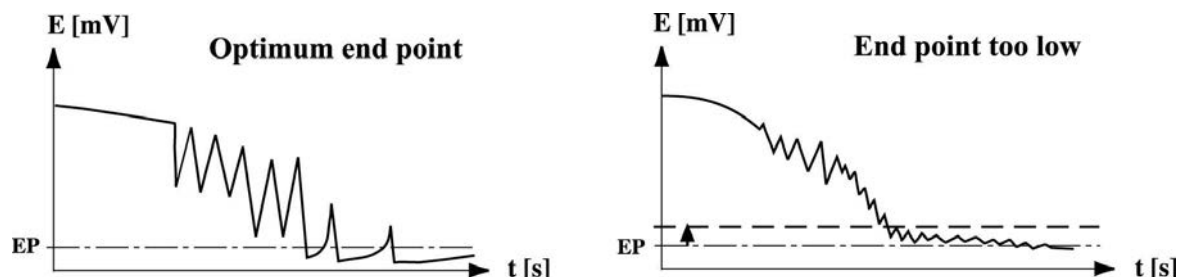

The consequences of choosing a too low end point value are illustrated in the figures above: On the right side, the titration curve is more or less flat towards the end; this results in an ill-defined titration end point, which will lead to long titration times and to low precision.

### 3.4.5 Application tips

#### Methanol based reagents

- The standard parameters listed in the table above are ideal for the titration with methanol-based reagents.
- If 1-comp titrants are used, the titration can be accelerated by reduction of the control band to 300 mV.
- If 2-comp titrants are used, the maximum dosing rate can be set higher for certain reagents: 4 mL/min for Riedel de Haen 2-Comp 5, up to 8 mL/min for most 2-Comp 2 titrants.

#### Ethanol-based reagents

- Compared to the methanol-based reagents, the system reacts slowly in the case of ethanol based reagents. If 2-comp ethanolic reagents are used, setting up of the titrant as 1-comp KF titrant yields shorter titration times.
- If 1-Comp titrants are used with Ethanol (e.g. Composolver E) the standard 1-Comp parameters (cf. table) work fine.
- In order to achieve a good repeatability, the sensor current shall be reduced to 15  $\mu$ A. This measure allows the system to cope with the reduced conductivity.

#### Auxiliary reagents

- If formamide is added to the solvent, the overall ionic conductivity is increased. This results in a lower voltage required to maintain the polarization current. Therefore the potential jump at the end of the titration is smaller compared to conventional reagents. If one-component reagents are used, the control band shall be decreased to 100 mV and the maximum dosing rate decreased to about 50%.
- If Chloroform or Xylene is added in order to dissolve oil samples, the overall ionic conductivity is decreased. Therefore it is recommended to decrease the polarization current to about 15  $\mu$ A.



**KF reagents for ketones**

- An end point value of 150 mV for both one-component and two-component reagents is recommended when using special KF reagents for aldehydes and ketones, where the methanol has been replaced by e.g. 2-methoxyethanol. Furthermore it is recommended to reduce the polarization current to a value of 15  $\mu\text{A}$ .

**3.4.6 General recommendations**

1. The most straight forward influence on the control behaviour is achieved by a variation of the maximum dosing rate. In the case of 2-comp reagents over titration can be prevented by reduction of the maximum dosing rate. If the titration takes too long, an increase of the control band is recommended.
2. There is no need to accurately adjust the control band to the actual start potential. However the control band shall not exceed the start potential. In most cases 300 – 400 mV are well-suited.
3. The minimum dosing rate shall be used to fine tune the final phase of the titration.

In general, the 1-Comp control is suitable for systems that show an oscillating potential behaviour, which is the case in 1-Comp systems. This control is also recommended for 2-Comp systems that show a noisy signal at the beginning of the titration, which is the case in some ethanolic reagents.

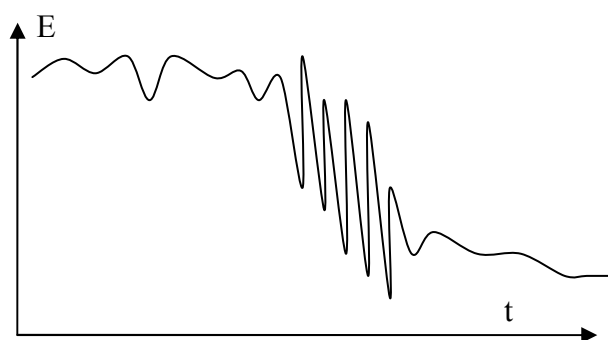

Oscillating system behaviour.  
->Use the 1-Comp control

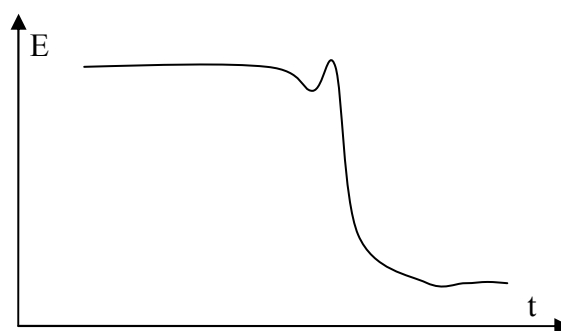

Smooth system behaviour  
->Use the 2-Comp control

**3.5 Control parameters in the coulometric KF Analysis**

An overview of the relevant control parameters is given as follows:

| Control  |           | Tasks |
|--|-----------|-------|
| Methods » Method » Titration (KF Coul) » Control |           |       |
| End point  | 100.0 mV  | 1 2 3 |
| Control band                                     | 250.0 mV  | 1 2 3 |
| Rate   | Normal    | ▼     |
| Generator current                                | Automatic | ▼     |
| Cancel   |           | OK    |

**End point**  
**Control band**  
**Rate: Normal, Cautious**  
**Generator current:**  
**Automatic, Fix (400, 300, 200, 100 mA)**

The iodine generation rate in the C20/C30 Coulometric Compact Karl Fischer Instruments depends on the distance from the end point. The closer the measured potential value from the predefined end point is, the slower is the generation of iodine.

More specifically, iodine is generated by means of current pulses of 400, 300, 200 and 100 mA. Variation of pulse length (time), pulse frequency and pulse height (mA) are used as variables by the instruments. In particular, the pulse height can be automatically changed by the system if in the titration method the control parameter "Generator current" is set to "Automatic", or it can be set to a specific value ("Generator current" - Fix). The fixed setting is used for solutions that exhibit a difficult characteristic with respect to conductivity.

The coulometer provides two different modes for iodine generation under the control parameter "Rate":

1. Cautious:  
Suitable for samples of low water content (e.g., less than 50-100 µg water per sample). The iodine generation starts slowly, i.e. the slope of the iodine generation rate is flat at the beginning of the titration. During the course of the titration it increases up to the maximum rate at a generating current of 400 mA.
2. Normal:  
This iodine generation mode is generally used for all water content determinations. Initially, the iodine generation is higher than in the cautious mode, i.e. the slope of the iodine generation is steeper and the rate is increased based on the measured potential value. During the course of the titration it increases up to the maximum rate at a generating current of 400 mA.

### 3.6 Termination parameters for both coulometric and volumetric KF titration

The KF titration can be terminated using various parameters. Since the first developed KF reagents reacted slowly, a delayed switch-off time of 10 to 20 seconds was set at the end point, i.e. as soon as the measured potential value was lower than the set end point during the defined delay time, then the titration was stopped. Later on, it has been possible to reduce the delay time to 5 to 10 seconds due to the introduction of

- new, pyridine-free reagents with a faster reaction rate,
- high resolution burettes (0.25 µL for a 5 mL burette), and
- improved KF titration stands (i.e. tightly sealed stand).

In addition, the online determination of the drift during analysis has enabled a so-called "drift stop" to be used as a termination parameter. This parameter shortens the titration time and leads to repeatable results.

Five termination parameters can be defined in the titration method: delay time, absolute drift stop, relative drift stop, maximum titration time, minimum titration time

### Delay time

The titration is terminated when the potential remains below the end point for a defined time (e.g. 15 s) following the addition or generation of iodine. The smallest increment must be sufficiently large to compensate the drift, otherwise the termination criterion is never satisfied.

Typical delay time: **5 - 15 seconds**  
(Coulometric/Volumetric)

- **Advantage:** well-known method.
- **Disadvantage:** The minimum rate must be adapted to the initial drift and the titrant concentration.

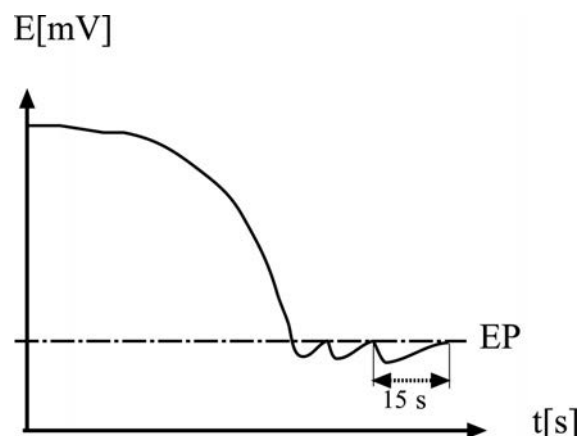

### Absolute drift stop

Termination occurs as soon as the actual drift drops below the predefined absolute drift value.

Thus, the absolute drift stop value must be greater than the initial drift, otherwise the termination criterion will never be reached.

Typical absolute drift stop value: **3 µg/min (coulometric); 10 µg/min (volumetric)**

- **Advantage:** Independent on the titrant concentration, easy to understand (volumetric).
- **Disadvantage:** The value has to be optimized to the initial drift.

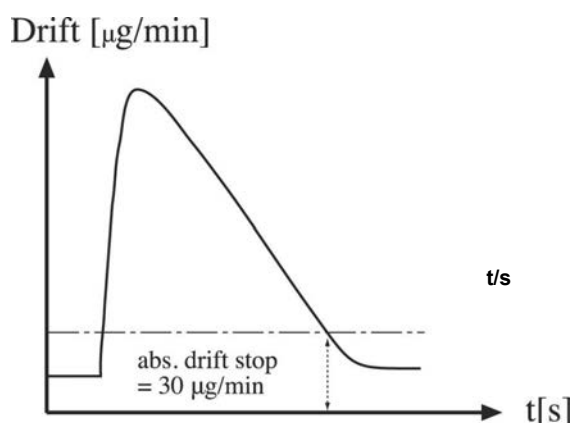

### Relative drift stop

The titration is terminated as soon as the actual drift drops below the sum of the initial drift (i.e. the drift before titration) and the relative drift.

Typical value for the relative drift stop =

**2-5 µg/min (coulometric), 5-15 µg/min (volumetric)**

- **Advantage:** independent on the initial drift, titrant concentration (volumetric) and side reactions.

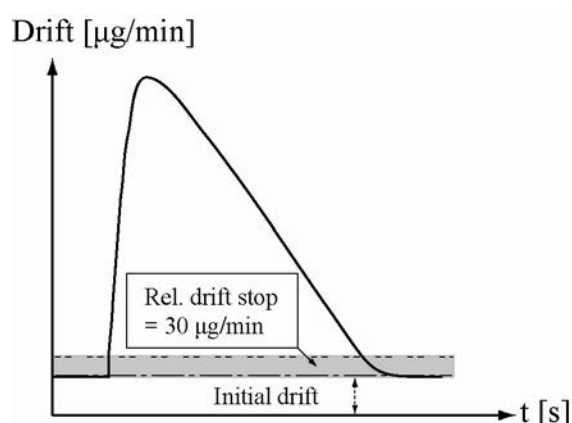

### - Maximum titration time

The titration is terminated after the defined time. After the defined time has elapsed, the titration is terminated and the result is printed.

- **Advantage:** This parameter ensures a high repeatability of the results, especially if working with the KF sample oven.

### - Minimum titration time

Titration is not to be terminated before this time in [s] is reached (exception: the maximum volume has been reached).

- **Advantage:** This parameter ensures a high repeatability of the results. It is recommended to be used for substances that release water slowly.

### 3.6.1 Using and optimizing the termination parameters for both volumetric and coulometric KF titration

The following termination criteria are most commonly used for water determination by Karl Fischer titration:

#### ***Relative drift stop for trouble-free, soluble samples***

You should normally choose the *relative drift stop* as a termination parameter. This parameter is independent of the the initial drift (coulometric, volumetric), and the titrant concentration (volumetric). Thus, this is the simplest and most universal parameter to use. The value of the relative drift stop influences the repeatability and the titration time:

- Drift stop (low value) → better repeatability → long titration time
- Drift stop (high value) → poorer repeatability → short titration time

In particular, the following values are recommended for volumetric KF titration:

*One-component reagent:* A relative drift stop value of 5 to 15 µg/min is an optimum value for achieving good repeatability. A relative drift stop of 20 to 30 µg/min shortens the titration time, but involves a risk that the titration will be terminated a bit too early, possibly resulting in poorer repeatability and lower water contents. This is particularly critical in connection with the "slower" reagents for ketones and aldehydes.

*Two-component reagent:* A relative drift stop value of 5 to 15 µg/min is an optimum value for achieving good repeatability. A relative drift stop of 20 to 40 µg/min shortens the titration time without affecting the repeatability.

This termination parameter is also well-suited when the *internal extraction* is needed to determine the water content in insoluble sample:

The water contained in insoluble samples is extracted during the titration. The final traces are only extracted very slowly. If the water content is relatively high, you can ignore these traces, i.e., you can terminate the titration at a higher drift (relative drift stop = 40 to 70 µg/min). Use the drift/time curve to determine this value.

#### ***Maximum titration time for determinations with the KF drying oven***

When using the drying oven, the drift at the end is often greater than the initial drift. The reason for this is either a very *slow release* of the last traces of water or a *slow thermal decomposition* of the sample. The vaporization of water is also irregular in the final stages, so

that the repeatability of the titration termination using the drift stop parameter is poor. The higher drift is therefore influenced to a large extent by the sample.

Therefore, the maximum titration time has proven to be best termination criterion in practice. It gives you the best accuracy and repeatability of results. (Set the minimum titration time equal maximum titration time).

Note: To obtain accurate and reliable results you should only work with the coulometer when the drift is *lower than 10 µg/min*. If the drift is greater than 10 µg/min, you should take measures to reduce the drift.

### ***Relative drift stop/maximum titration time for problematic samples***

Some samples lead to a high drift value at the end of the titration. This is the case with samples that only release the final traces of water very slowly or that produce side reactions. A combination of the *relative drift stop* and the *maximum titration time* has proved effective for such samples. If the drift stop value is not reached, the titration is terminated at the latest after the defined maximum time.

## 4. The Karl Fischer titration

Various factors must be taken into account with Karl Fischer titration to obtain correct results. The factors include:

- the atmospheric humidity
- the working medium
- the pH of the sample
- the side reactions between the sample and the Karl Fischer reagent

### 4.1 The influence of atmospheric humidity (drift determination)

Atmospheric humidity represents the most relevant source of error in Karl Fischer titration. Moisture can enter the *sample*, the *titrant* and the *titration stand*. This problem is particularly relevant in tropical climates or in coastal regions, where the relative humidity can achieve values of more than 80%.

The assumption that air-conditioned rooms have a lower atmospheric humidity is often not true: the majority of air-conditioning systems simply cool the air. However, since cold air cannot absorb as much moisture, the relative humidity increases. Briefly, the higher the atmospheric humidity in the laboratory, the greater is its influence on the results of the Karl Fischer titration. The air-conditioning system should therefore be equipped with a moisture condenser.

The Karl Fischer titrator should *never be installed* close to a ventilator of the air conditioning system!

#### 4.1.1 Titration stand

The titration stand must be sealed as tightly as possible against atmospheric moisture. The following rules should be observed:

- Close all openings in the titration stand.
- Condition the titration cell before use.

When you assemble the titration stand for the first time, there will be moisture on the glass surface of the titration cell and the inserts. The air within the titration vessel also contains moisture. After the anolyte (coulometer) or the solvent (volumeter) has been added, it is titrated to dryness during pretitration, i.e. until it is absolutely free of water.

The drift, however, remains high because the moisture present on the glass walls and the air in the titration cell diffuse only slowly into the anolyte (solvent). This can take 1 - 3 hours. The total moisture can be titrated more quickly by gently moving the vessel from side to side so that solvent swirls up the side of the vessel to pick up moisture adsorbed on the glass walls. In this way, the residual moisture dissolves more rapidly into the anolyte (solvent). Do not shake too vigorously to avoid solvent gets on the cover of the vessel.

- Protect the titration cell with a desiccant (3 Å molecular sieve and silica gel).

The desiccant absorbs the moisture and protects the titration cell against the ingress of moisture. The drying capacity of the desiccant is limited and it depends on the humidity and can be exhausted after 2 - 4 weeks (indicated by a colour change of the indicator of the silica gel).

Silica gel can be regenerated over night at 150 °C, whereas molecular sieves require temperatures up to 300 °C.

### 4.1.2 The drift

No titration stand is completely water tight; traces of water will always find a way into the titration cell. On the other hand, this water amount is also titrated during analysis. Therefore it must be taken into account when calculating the water content.

In this respect, it is necessary to quantify the amount of water entering the titration cell during titration. Therefore, the **drift** indicates the quantity of water that enters the titration stand over a defined period, t, and is given in **µg water/minute**. This is achieved by titration of the dry solvent for a defined time (drift determination).

In the standby titration, the KF titrator continuously titrates the water that diffuses into the cell, and its value is displayed on the screen. At the start of a sample titration, the last measured drift value is automatically stored, if it is defined as the parameter "**Source for drift: Online**" in method function "Titration stand (KF stand)".

On the other hand, it is also possible to use the value of a previously performed drift determination ("**Determination**"), or a fixed value can be defined into the titration method ("**Fix value**"), or it can be entered by the user ("**Request**"):

| Source for Drift | Explanation  |
|------------------|--|
| Online           | Last measured value of standby                                       |
| Determination    | The drift is determined and stored as raw result DRIFT               |
| Fix value        | A fixed value is defined into method                                 |
| Request          | The value can be entered immediately after starting sample titration |

The drift value is subsequently used in the calculation of the result in order to compensate for the moisture that entered the titration cell according to the following formula:

$$\text{Sample result} = \text{Total amount of water determined} - (\text{drift} * \text{titration time}).$$

For accurate results, the drift value should therefore be as low as possible and stable before the start of a titration!

## 4.2 Working with the coulometric KF instruments

### 4.2.1 Filling the coulometric cell

- *Cell with generator electrode with diaphragm*
  - First transfer 5 mL catholyte to the cathode compartment.
  - Take approx. 5 mL from the bottle with a syringe and inject it into the generator electrode or empty an ampoule of catholyte into the generator electrode.
  - Then fill the anode compartment with approx. 100 mL anolyte.
  - Make sure that the level of the anolyte is approx. 3 - 5 mm higher than that of the catholyte. The catholyte always contains traces of water. If the level of the catholyte is the same or higher, a flow occurs from the cathode compartment to the anode compartment, the moisture enters the diaphragm and is slowly released into the anode compartment, which leads to a higher drift. This can be avoided as it follows:
    1. The catholyte can be dehydrated with a few drops of a volumetric KF one component titrant.
    2. By ensuring that the level of the anolyte is higher than the one of the catholyte.

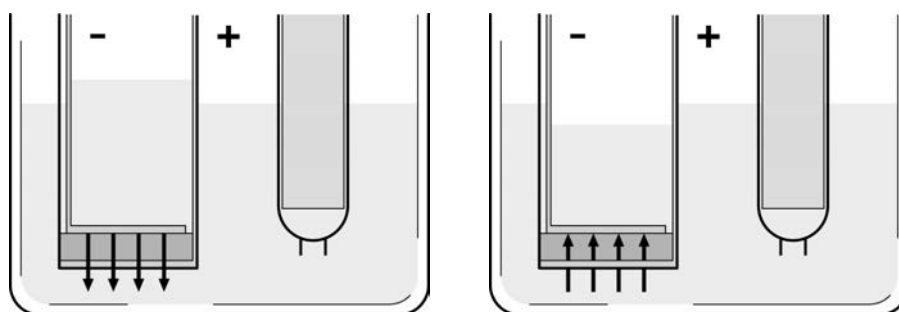

Lower anolyte level → drift is high

Higher anolyte level → low drift

- The difference in level between the anolyte and catholyte is maintained as long as the stirrer is in operation. As soon as the stirrer is switched off, the levels slowly become the same.
  - When a sample is injected into the anode compartment, the level of the anolyte increases. However, when the drying oven is used, the level of the anolyte drops due to evaporation. In this case, the anolyte should be topped up from time to time with anhydrous methanol.
- *Titration cell with diaphragmless generator electrode*
    - Pour approx. 100 mL electrolyte solution (anolyte) into the titration cell.
    - The generator electrode should dip approx. 2.5 cm into the electrolyte solution.

Note:

In production, some anolyte solutions contain an excess of iodide and the solution has a brown colour. Normally this brown coloration disappears on filling the titration cell because the iodine excess is consumed. If this is not the case, you must add some methanol or sample so that the color changes to yellow.



#### 4.2.2 When do you have to replace the electrolyte?

The electrolyte must be replaced in the following situations:

- If the capacity of the electrolyte is exceeded.
  - Anolyte solutions (100 mL): after 1000 mg water,
  - Catholyte solutions (5 mL): after 200 mg water.The capacity is monitored by the coulometers (see operating instructions).  
*In practice*, when using a generator electrode with diaphragm, it is common use to replace both the anolyte and catholyte at the same time
- If after adding samples, the level of the solvent or the anolyte exceeds the 150 mL mark.  
The higher the level in the anode compartment, the worse the stirring efficiency will be, and the risk of over titration increases.
- If the conductivity of the anolyte drops to a very low value, e.g. below 10  $\mu$ S.  
This can happen if large amounts of samples of low conductivity are titrated.
- If an emulsion forms in the anode compartment.  
With poorly soluble samples, the dissolving capacity of the anolyte (coulometric KF) is exhausted and an emulsion is formed. This can lead to wrong results.
- If the drift is too high.  
If an electrolyte is used for a long period without replacement, the drift slowly increases.
- After being used for two weeks.  
In the cathode compartment sulfides and mercaptans are formed that lead to an obnoxious smell and a higher drift.

#### 4.2.3 Secure draining and filling of the titration cell: SOLVENT MANAGER

The easiest and secure way of draining and filling the coulometric titration cell is performed with the external KF liquid handling device Solvent Manger. The Solvent Manager is located on top of the waste bottle and includes strong air pump (diaphragm pump) and an electromagnetic valve. It is fully controlled by the titrator. A level sensor in the waste bottle prevents from overflow. Any contact with the reagent is avoided during draining and refilling of the titration cell.

The working principle of the Solvent Manager is illustrated in the following schematical illustrations:

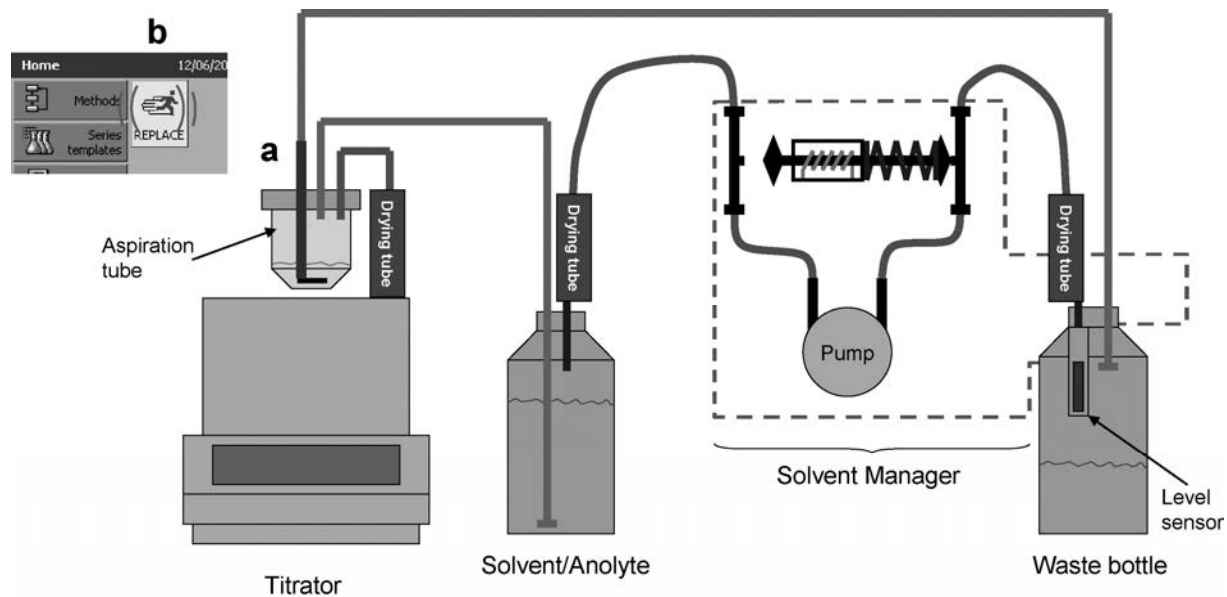

Step 1a: Put the draining and reagent refill tube into the coulometric titration cell.

Step 1b: Start the reagent replacement either from the manual function 'Replace reagent' or from a predefined Shortcut on the Home screen of the Touchscreen.

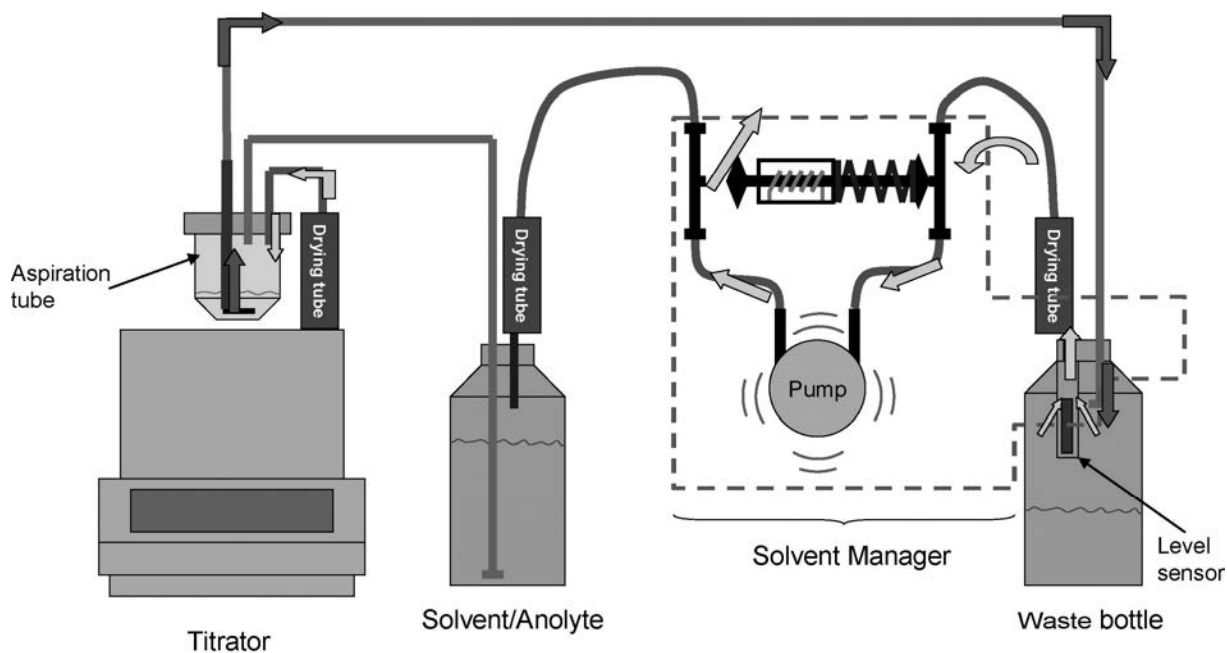

Step 2: The Anolyte is drained into the waste bottle by applying vacuum.

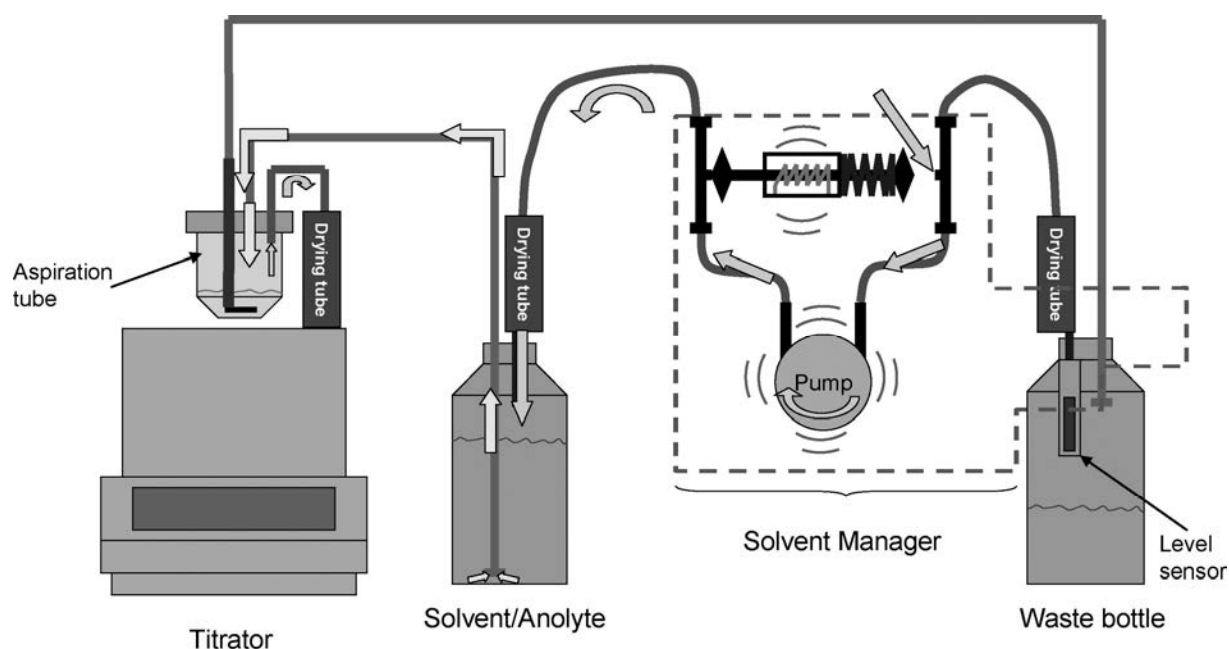

Step 3: The pump direction is switched by activation of the magnetic valve and subsequently fresh solvent is pumped into the titration cell by applying over pressure of dry air.

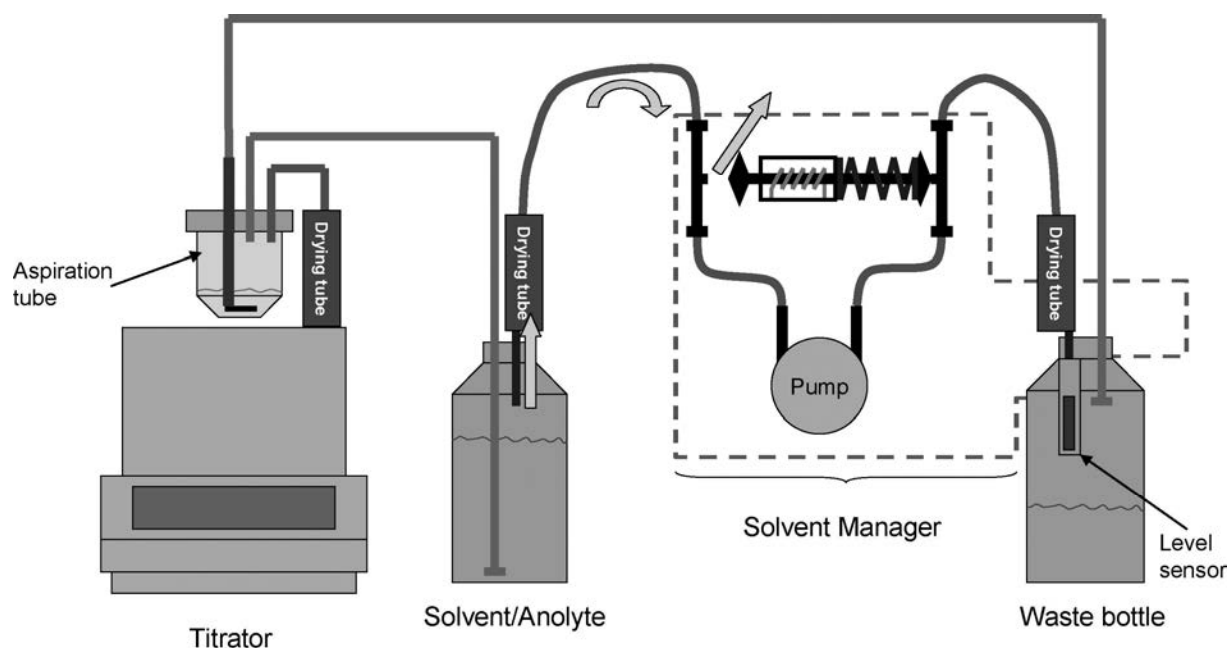

Step 4: After a predefined time or by manual interaction the pressure within the solvent/anolyte bottle is relieved by switching the magnetic valve into the initial position.

The Solvent Manager is part of the standard delivery of the C20 and C30 Compact coulometric KF titrators. In this configuration only draining of the titration cell is possible. An optional reagent exchange set consisting of tubes, drying tube and tube holder enables both draining and refilling. Depending on the type of the generator cell the following liquid handling actions can be performed:

- Diaphragmless generator cell: Replacement of the anolyte
- Generator cell with diaphragm: Replacement of the anolyte and draining of the catholyte

Note: The tubes for anolyte exchange are not left in the titration cell during titration, since it would cause a higher drift value.

The C30 provides a reagent monitoring routine which is called Reagent Control. It provides the following:

- Monitoring three reagent parameters
  - Usable life in days
  - Capacity in mg water
  - Number of samples
- When due, reagents can be replaced directly out of running method
- Choice of enforcing the user to replace it immediately or ask again later

#### 4.2.4 Cleaning the coulometric KF titration cell

The titration cell and both electrodes should be cleaned, especially if dirty samples are analyzed. The generator electrode with diaphragm must be cleaned *periodically* because contamination accumulates in the diaphragm over a longer period of time, which leads to a *higher drift*. The contaminants can originate from samples or are side products that have been formed in the cathode compartment by reduction.

- **Cleaning the titration vessel**

Clean the titration vessel with water or a suitable solvent. Afterwards dry the vessel at 100 °C in an oven or with a hot air drier. If immediate use is required rinsing with anhydrous methanol shall be applied.

- **Simple cleaning and drying of the generator electrode**

*Method A:*

- Place the empty generator electrode in anhydrous methanol.
- Methanol flows through the diaphragm into the cathode compartment. Moisture and contaminants are rinsed out of the diaphragm.

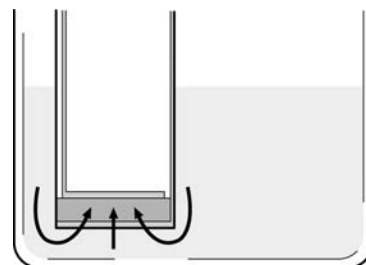

*Method B:*

- Fill the generator electrode with anhydrous methanol. Methanol flows through the diaphragm and rinses out moisture and contaminants.
- This procedure should be repeated at least once.
- Afterwards dry the generator electrode at a maximum temperature of 50 °C in an oven or with a hot air dryer. Drying is not necessary if you use it immediately.

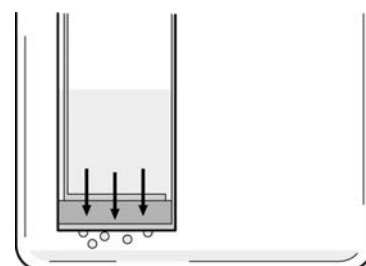

- **Thorough cleaning of the generator electrode**

If the generator electrode and the diaphragm are strongly contaminated, the most effective cleaning agent is chromic acid. The procedure is identical to that described above. Place the empty generator electrode in the chromic acid or fill the generator electrode with chromic acid and let it flow through.

Afterwards thoroughly rinse the generator electrode with water, then with anhydrous methanol and dry it as described above.

### 4.2.5 Cleaning the measuring electrode

Generally, the indicating electrode does not need cleaning. As already described, a layer is formed on the platinum surface after the first few titrations. This leads to a higher potential jump. The layer should therefore *not be removed* by cleaning.

However, samples may be deposited on the surface of the electrode. The Ohmic resistance of the electrode is increased, which prevents a good indication. This also becomes noticeable through a dark coloration of the anolyte at the end point. In this case, the measuring electrode must be cleaned.

- Clean the platinum pin with a paper tissue. This is sufficient in most cases.
- With heavily contaminated electrodes, place the electrode in 0.5 mol/L sulfuric acid, and let an electrical current of about 400 mA flow across the platinum pins for 60 s by starting the KF titration:
  - 1) Disconnect the S7 connection of the indication electrode.
  - 2) Connect the S7 connection of the generator cell with the indication electrode.
  - 3) Stop the method when the cleaning is finished so that the polarization current at the indication electrode is stopped.

## 4.3 Volumetric KF Titration: Titrant concentration

The titrant concentration can change due to the following reasons:

1. The titrant is *not chemically stable*, e.g. the one-component titrant.
2. The titrant may absorb moisture from the atmosphere reducing its concentration (the anhydrous methanol in the titrant is very hygroscopic)
  - if the desiccant on the titrant bottle is "used up",
  - if the titrant bottle is not tightly sealed.
3. A significant change in temperature may occur: The Karl Fischer titrants consist of approximately 90% methanol or ethanol. Their volume increases considerably with temperature, so that there is a sharp drop in concentration.

### 4.3.1 How often should the concentration be determined?

How often the concentration is determined depends on the *choice of titrant*, the *tightness* of the titrant bottle and the *desired level of accuracy*.

Based on the chemical stability of the titrant, a weekly titer determination would be sufficient (the concentration of the one-component titrant changes by 0.01 mg/mL per week, while the two-component titrant is rather stable).

**We recommend to determine the titrant concentration daily.**

In countries where the temperature varies considerably during the course of the day and the lab is not air-conditioned, it is better to determine the concentration every 2 to 4 hours.

The tightness of the titration stand and the proper functioning of the burette and the end point indication are also checked at the same time as the concentration is determined. This test of the complete system by a titer determination is therefore an essential condition for accurate, repeatable results.

The volumetric KF titrators enable monitoring of the usable life and life span of the titrant. A reminder can be set to warn the user at the start of every titration that the usable life is about to expire in the predefined time range (days). In the global settings within the setup menu of

the titrator actions can be defined that will be applied if the usable life or life span is actually exceeded. Either the user is simply warned or the usage of the expired titrant is blocked, which prevents the execution of further titrations.

*Note:*

1. Rinse the burette 2 times into a waste bottle before you determine the concentration. The plastic tubing is *not absolutely water vapor-tight*, thus the titrant concentration slightly but continuously decreases slightly when left to stand for a long time.
2. Determine the concentration under the same conditions as for sample analysis, i.e.:
  - using the *same titration stand* with the *same volume of solvent*,
  - and at the *same temperature*.

### 4.3.2 Concentration determination with di-sodium tartrate dihydrate

*General*

Di-sodium tartrate dihydrate,  $\text{Na}_2\text{C}_4\text{H}_4\text{O}_6 \cdot 2\text{H}_2\text{O}$  (M = 230.08 g/mol), is the primary standard for Karl Fischer titration since it is stable and non-hygroscopic. Under normal conditions, it contains 15.66% of water. Since it slowly dissolves in methanol, you should first grind it to a fine powder before using it or use special Di-sodium tartrate dehydrate for Karl Fischer Titration

*Procedure*

- Use the optimized METTLER TOLEDO method M301
- Weigh between 0.04 and 0.08 g di-sodium tartrate dihydrate with the aid of a weighing boat. This sample size yields an optimum titrant consumption of 1.3 to 2.5 mL with a 5 mL burette, i.e. 26-50 % of burette volume.
- Add it into the titration vessel. Make sure that nothing adheres to the beaker wall or to the electrode.
- Determine the weight by back weighing and enter it as sample size.
- Mix for 3 minutes to achieve complete dissolution before you start the titration.

*Solubility of di-sodium tartrate dihydrate*

Di-sodium tartrate dihydrate must be completely dissolved (clear solution!) to obtain correct results. A cloudy solution will falsify the results (i.e. too high titer). Thus, always take into account the limited solubility of di-sodium tartrate dihydrate in the most commonly used solvents for Karl Fischer titrations:

|   |   |
|---|---|
| <b>In Solvent*</b>  | Highly soluble, mixing time 1 minute.<br>You can perform six determinations in 30 mL of Solvent* before you need to change it.  |
| <b>In Solvent*/chloroform mixture 1:1<br/>or<br/>Solvent*/decanol mixture 1:1</b> | Slightly soluble, mixing time 5 minutes.<br>You can only perform one determination in 50 mL of 1:1 mixture (with 0.05 g di-sodium tartrate dihydrate).<br>You must either change the solvent after every sample or use pure Solvent* for the determination. |
| <b>In Solvent*/formamide mixture 1:1</b>  | Highly soluble, mixing time 1 minute.   |
| <b>In methanol</b>  | Less soluble, mixing time 2 to 3 minutes.<br>You cannot perform more than three determinations in 40 mL of methanol (with 0.045 g di-sodium tartrate).  |
| <b>In methanol/chloroform mixture 1:1<br/>or<br/>methanol/decanol mixture 1:1</b> | Partially soluble.<br>The values obtained are approximately 10% too high.<br>You must perform the determination in pure methanol!   |
| <b>In methanol/formamide mixture 1:1</b>  | Highly soluble, mixing time 1 minute.<br>You can perform eight determinations in 40 mL of this mixture before you need to change the solvent.   |
| <b>In solvent for aldehydes and ketones<br/>(one-component reagent)</b>           | Partially soluble.<br>The values that are obtained are approx. 30% too high.<br>You must perform the determination in pure methanol!  |
| <b>In ethanol</b>   | Less soluble, mixing time 2 to 3 minutes.<br>You cannot perform more than one determinations in 40 mL of ethanol (with 0.05 g di-sodium tartrate).  |

\*Solvent: solvent for the two-component reagent

**4.3.3 Concentration determination with Water Standard 10.0 mg/g***General*

Water standards consist of a mixture of organic solvents containing a specific amount of water, e.g. "HYDRANAL®-Water Standard 10.0" from Sigma-Aldrich® with 10 mg water in 10 g standard. This content is confirmed by the test certificate enclosed with every package.

The water standards are supplied in glass ampoules. They are thus protected against the ingress of moisture and can be stored for up to five years.

*Procedure*

To achieve an optimum consumption of 2 to 3 mL titrant with a concentration of 5 mg/mL, you should weigh in 1.0 to 1.5 g of water standard 10.0.

- Open the ampoule shortly before the measurement in accordance with the enclosed instructions.
- Rinse a 10 mL syringe with approximately 1 mL of water standard.
- Draw the whole content of the ampoule into the 10 mL syringe.
- Inject 1 to 1.5 mL at a time as an aliquot.
- Determine the weight by back weighing. The content of an ampoule is sufficient for 3 to 5 determinations.
- Start the titration without any mixing time.

#### Notes

1. Use the METTLER TOLEDO method M300
2. The water standard is highly soluble in all commonly used solvents for Karl Fischer titration and can therefore be used without restrictions.
3. You can use a water standard with 1.0 mg water/g for a titrant concentration of 2 or 1 mg/mL.
4. Use a new ampoule for each new concentration determination. In an open ampoule the liquid standard is exposed to air moisture, the water content is increased and thus this will falsify the results.
5. To reduce the influence of the atmospheric moisture, the whole content of the ampoule is completely drawn into the syringe.
6. Plastic syringes may introduce a small amount of moisture. The error is minimized by rinsing and conditioning the syringe beforehand. Glass syringes are better.

### 4.3.4 Concentration determination with pure water

#### General

When using pure water to determine the concentration, a very good deal of practice and precise working is required to obtain repeatable, accurate results. This is due to the *very small amount of sample* (10 to 20  $\mu\text{L}$ ) that has to be injected. Thus, it is strongly recommended determining the concentration either with di-sodium tartrate dihydrate, or with a 10.0 mg/g water standard.

#### Procedure

- You should weigh between 10 and 20  $\mu\text{L}$  of deionized water or water according to ISO 3696 to achieve a consumption of 2 to 4 mL titrant with a concentration of 5 mg/mL.
- The sample should be weighed either using a balance *with a resolution of 0.01 mg* (e.g. METTLER TOLEDO XP205 balance) or with a *10 or 20  $\mu\text{L}$  precision syringe* (e.g. with a Hamilton microliter syringe). A balance with a resolution of 0.1 mg does not satisfy the requirements for a repeatable titration.
- Inject exactly 10.0  $\mu\text{L}$  deionized water with a 10  $\mu\text{L}$  syringe.
- Enter 0.01 g as the sample size.
- Start the titration without any mixing time.



### Notes

1. It is possible to determine the titrant concentration with water in all the solvents commonly used for Karl Fischer titration.
2. You should always observe the following points when determining the concentration with a 10 µL syringe:
  - Precondition the 10 µL syringe for approximately one hour by filling it with water. All the screws in the syringe must be tightened securely.
  - You can get rid of any bubbles in the syringe by expelling the water rapidly.
  - Do not warm the syringe. Always use a syringe with a long metal shaft, to avoid touching the glass part.
  - Adjust the plunger to exactly 10.0 µL.
  - Hold the syringe at right angles directly in front of your eyes to read off the value.
  - After setting the volume, wipe off any drops that have adhered to the needle with two fingers (be careful if you use a paper towel; if it is absorbent, it may draw water out of the needle!).
  - Always add each sample in exactly the same way.
  - Insert the syringe through the 1 mm hole of the three-hole adapter, lay it down on the adapter and empty it completely.

### 4.3.5 The solvent

To determine the water content in a sample, the sample must release water completely. Only freely available water undergoes reaction with the Karl Fischer reagent. You can use mixture of solvents to achieve complete dissolution.

However, the largest part of the solvent mixture must always be an alcohol (most preferably methanol) to ensure that the Karl Fischer reaction is strictly stoichiometric.

| Solvent  | Max. amount | Samples   |
|--|-------------|---|
| <b>Methanol</b>                                      | 100%        | Solvents: toluene, dioxane, alcohols, ester<br>Organic products: urea, salicylic acid<br>Foods: honey, yogurt, beverages<br>Cosmetics: soaps, creams, emulsions |
| <b>Chloroform</b>                                    | 70%         | Petrochemical products:<br>crude oil, hydraulic oil, transformer oil, fat   |
| <b>Decanol<br/>Octanol<br/>Hexanol<br/>Dodecanol</b> | 50%         | Oils: edible oil, massage oil, ethereal oils<br>Petrochemical products: gasoline, diesel oil, kerosene<br>Pharmaceutical products: ointments, fatty creams      |
| <b>Toluene</b>                                       | 50%         | Waxes, tar products, suppositories  |
| <b>Formamide</b>                                     | 50% (30%)   | Sugar products: jelly, caramel, jelly bears<br>Starch products: flour, corn, noodles, potato chips  |

### Notes

1. The solvents that are used should contain as few water as possible (< 100 ppm), or the titration will take too long and titrant will be wasted.
2. If acidic or basic samples are titrated, buffering agents are first added to the solvent to ensure that the titration is quick and without side reactions:
  - imidazole is used for acidic samples, and
  - salicylic or benzoic acid for basic samples.
3. Sugar is the only type of sample that dissolves in formamide, starch products will not dissolve in it. On the other hand, formamide effectively extracts water from starch products. The extraction capacity can be improved by increasing the temperature (e.g. 50°C). The amount of formamide at 50 °C should not exceed 30%, or the stoichiometry of the Karl Fischer reaction will change and the results will be wrong.

#### 4.3.6 Dissolving capacity of the solvent

The dissolving or extraction capacity of the solvent is a crucial factor in Karl Fischer titration. If exhausted, the water will no longer be completely released. This will lead to incorrect results, i.e. too low water content. Therefore, it is necessary to replace the solvent timely.

The solvent for the two-component reagent contains SO<sub>2</sub>, which may be completely expended if you titrate a large number of samples with high water content. In this case, the titration of subsequent samples will then be very slow. Once again, you must replace the solvent timely.

The Compact Line KF titrators are able to monitor the solvent capacity: the user can define when the solvent should be replaced by specifying the usable life, the amount of water in mg which has been titrated, or by indicating the maximum number of samples to be titrated. The titrator accumulates the total water amount continuously during titrations and reports "Solvent capacity exhausted" as soon as the specified value is exceeded.

## 5 Sampling

### 5.1 Taking the sample

When taking samples for water determination, you must be extremely careful to exclude atmospheric moisture - the most common source of error. If the water content of a sample changes during sampling due to moisture being absorbed or desorbed, you will no longer be able to determine its true water content.

***"An analysis cannot be better than the actual sample!"***

When sampling, you should take into account the following points:

1. The sample must be representative, i.e. it must contain the same average amount of water as the material as a whole.
2. The sample should be taken quickly to exclude, or at least minimize, the absorption or release of moisture.
3. Heterogeneous water distribution in samples:  
In *non-polar liquids*, e.g. oils, the water is *not uniformly dispersed*. It floats on the surface or sinks to the bottom. Liquids of this type must be thoroughly mixed (by shaking) before a sample is taken.  
In the case of *non-polar solids*, such as butter, which cannot be mixed as thoroughly as liquids, the sample should be larger the more heterogeneous the distribution of the water.
4. Hygroscopic solids may exhibit *higher water content* on the surface than inside if they have absorbed atmospheric moisture during storage.
5. Substances with **very low water content**:  
Substances with a very low water content are frequently extremely hygroscopic. The sample must therefore be taken very quickly and with a syringe or a spatula that is absolutely dry.

### 5.2 Storing the sample

After you have taken the sample, you should determine its water content **as soon as possible**. If you have to store the sample, keep it in a tightly sealed bottle:

- Glass bottles are preferable to plastic bottles because plastic is not completely gas-tight, and thus air moisture can penetrate the plastic and be absorbed by the sample.
- Use sample bottles with *small openings* to minimize the ingress of moisture.
- Use bottles with a *septum stopper* for liquids of *very low water content*.
- Use a bottle with an *optimum volume* for the amount of sample: the smaller the gas space above the sample, the lower the amount of moisture.
- With **liquid samples**, rinse the bottles two or three times with the sample beforehand.

With liquid samples that do not dissolve water such as oils, water may be separated from the sample if it is left to stand for a long time. This can happen when a sample cools and the water solubility is decreased. In such cases, the solubility of water in the sample can be increased using a solubility promotion agent such as 2-propanol.

### 5.3 Amount of sample

The amount of sample used depends on

- the *expected water content*, and the
- *required accuracy and precision*.

For **coulometric analyses**, the optimum amount of water is in the range from **0.5 to 2 mg** water per sample. Repeatable results can be obtained even with 0.1 mg water per sample. Under optimum measurement conditions, approx. 10-50 µg water can be detected if the demand for repeatability is not too high.

In general, the accuracy is improved if *larger sample amounts* are used, because the absorption of atmospheric moisture during sampling or sample addition becomes less important.

For optimum accuracy with determinations in the range from **1 ppm to 1% water**, it is recommended to use the minimum sample size given in the following table:

| Water content [ppm]  | 1    | 10   | 50   | 100 | 500 | 1000 | 5000 | 10000<br>= 1% |
|----------------------|------|------|------|-----|-----|------|------|---------------|
| Min. sample size [g] | 10   | 8    | 5    | 4   | 2   | 1    | 0.2  | 0.1           |
| Amount of water [mg] | 0.01 | 0.08 | 0.25 | 0.4 | 1.0 | 1.0  | 1.0  | 1.0           |

For **volumetric titrations**, the optimum amount of water is approximately **10 mg** per sample. As a rule of thumb, the accuracy increases with the amount of sample, because the absorption of air moisture during sampling and sample addition becomes less important.

If a high level of accuracy is required, the amount of sample should require a titrant consumption between **30 and 70%** of the nominal burette volume. This corresponds to 7.5 to 17.5 mg water per sample for a 5 mL burette with a titrant concentration of 5 mg/mL.

Water content determinations below 1000 ppm are not required to be quite as accurate: a relative standard deviation  $s_{rel}$  of 1 to 5% is generally considered as acceptable for such values. A titrant consumption of 0.1 to 0.05 mL is thus still acceptable when using a 5 mL burette. This corresponds to 0.1 to 0.05 mg water per sample with a titrant concentration of 1 mg/mL.

For a more accurate determination of water traces (10 ppm to 1000 ppm) by volumetric KF titration, a KF titrant with a lower concentration (1 or 2 mg/mL) has to be used, and the following minimum sample sizes should be used:

| Water content [ppm]  | 10 | 50 | 100 | 200 | 500 | 1000 |
|----------------------|----|----|-----|-----|-----|------|
| Min. sample size [g] | 8  | 7  | 5   | 4   | 3   | 2    |

**Determination of the amount of sample for a water content in the range  
from 1000 ppm to 100%**

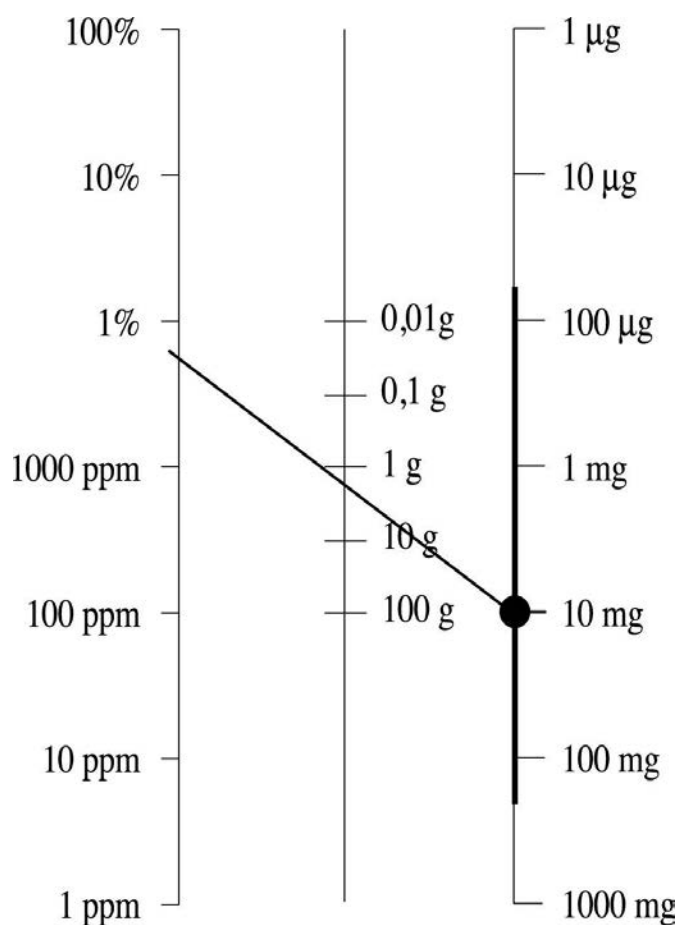

**Principle:**

The recommended sample size can be determined as a function of the expected water content for optimum KF analysis.

**Procedure:**

- Start from the *optimum point* (10 mg for volumetric KF, 1 mg for coulometric KF) or the recommended range
- The optimum point is connected by a straight line to the expected water content.
- The intersection point of this line with the "Amount of sample" scale represents the recommended amount of sample to be used.

**Note:** Logarithmic scale!

Example:

Expected water content: 5000 ppm  
Optimum amount of water: 10 mg/sample  
Optimum sample amount: 2 g

The Compact volumetric and colometric KF titrators support the user with a sample size calculation routine, which is accessible in the online titrations screen:

**Suggested sample size** Tasks

Sample 1/1 » KF functions » Sample size

Determination: Sample ▼

Content: 5

Unit: % ▼

Lower limit: 0.15 g

Upper limit: 0.35 g

Cancel Calculate OK

Dependent on the expected water content, an optimum sample weight range is recommended.

## 6 Sample addition

### 6.1 Liquid samples

When adding liquid samples, you must take suitable precautions to prevent atmospheric moisture from being absorbed, especially with samples of low water content. The following procedures are suitable for the different types of liquid samples:

| Sample characteristics   | Examples  | Procedure  |
|--|---|--|
| <b>High water content</b><br><b>Low viscosity</b>                          | perfumes, aqueous emulsions, alcoholic beverages                  | Inject the sample into the titration vessel either through a septum (KF coulometer) or through the needle hole in the three-hole adapter (volumetric KF titrator) using a 1 mL syringe with needle.  |
| <b>Low water content</b><br><b>Low water content</b><br><b>Hygroscopic</b> | methanol, edible oils, hexane, toluene, benzene                   | Store the sample in a bottle with a septum stopper to avoid moisture absorption from the air.<br>Rinse a 10 mL syringe 2-3 times with the sample<br>Inject the sample using a 1 mL or 10 mL syringe through a septum cap.  |
| <b>Viscous</b>   | glycerol, hydraulic oils, silicone oil, mineral oils, massage oil | Inject the sample using a 5 or 10 mL syringe with a thick needle into the titration cell. Possibly warm the sample slightly to lower the viscosity.<br>In the case of a volumetric Karl Fischer titrator, you can use a <b>syringe without needle</b> since the sample can be added via the larger hole of the three-hole adapter. |
| <b>Very viscous</b>  | ointments, creams, yoghurt, honey                                 | Fill the 5 or 10 mL syringe with sample after removal of the piston. Inject it into the cell using a wide-bore needle.<br>In the case of a volumetric Karl Fischer titrator, you can use a <b>syringe without needle</b> since the sample can be added via the larger hole of the three-hole adapter.                              |
| <b>Waxy</b>  | candle wax, paraffin, ski wax, suppositories                      | Liquefy the sample in an oven at approx. 50 °C and fill it into a syringe.<br>The syringe is heated together with the wax.<br>This prevents the sample from solidifying in the syringe during the weighing.  |

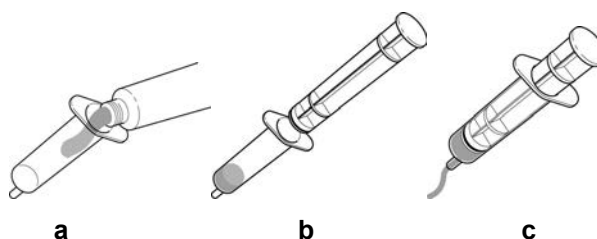

### Taking samples from a bottle with septum stopper

After several samples have been taken, a vacuum develops in the bottle with septum stopper and it will no longer be possible to take a sample aliquot. To avoid this, you must aerate the bottle with dry air (equalize the pressure).

Fill a syringe without a plunger with molecular sieves, seal it with cotton wool and insert it into the septum bottle using a short needle. Air flows through the molecular sieve into the bottle when you take a sample aliquot.

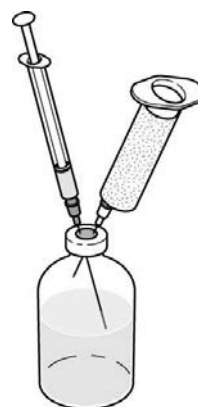

### Sample addition of liquids with the back weighing technique

- Fill the syringe to a quarter with sample. If the sample is hygroscopic or has a low water content (< 1000 ppm), use bottles with a septum stopper and pressure equalization.
- Withdraw the plunger and rinse the syringe with the sample by shaking it.
- Empty the syringe (into the waste bottle) and repeat the rinsing two or three times.
- Fill the syringe with sample and wipe the needle with a paper tissue.
- Place the syringe (upside down) in a beaker on the balance pan and tare the balance to "0".
- Start the titration method by pressing the <Start> button
- Inject the sample into the titration cell through the septum stopper.
- Withdraw the plunger so that the drop at the tip of the needle is sucked back into the needle. Otherwise when the syringe is removed, the drop will adhere to the septum.
- Replace the syringe with the remaining sample on the balance and back weigh it.
- Enter the sample size in the titrator or transfer it automatically.
- Start the titration.

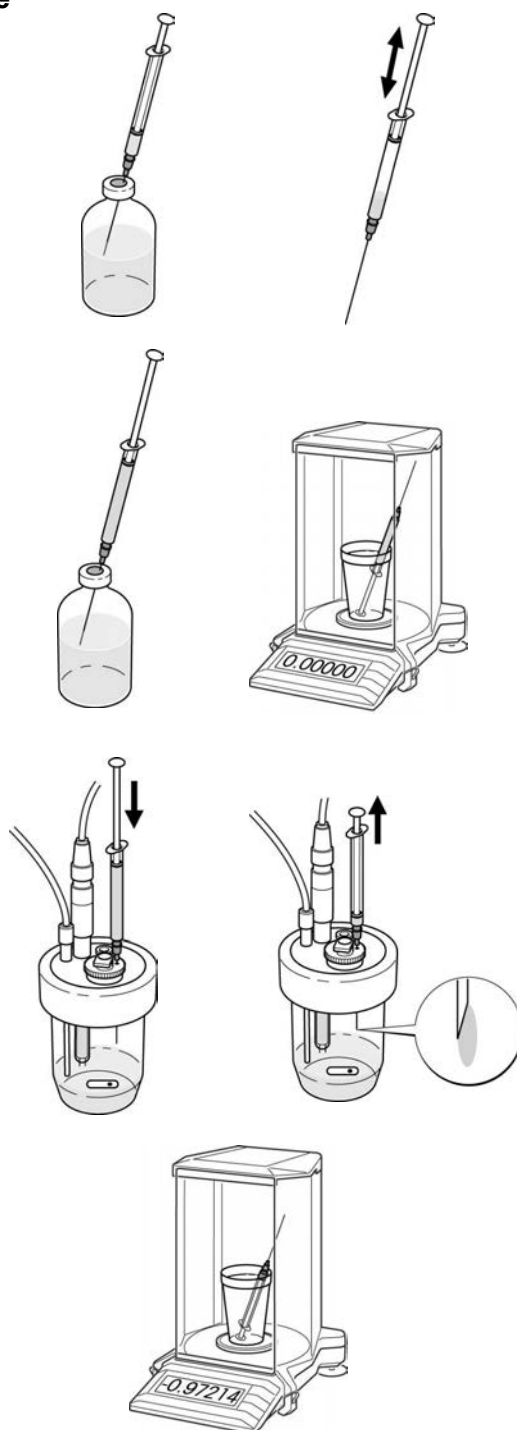



## 6.2 Solid samples

It is **not possible** to directly titrate solid samples using **KF coulometry** - when the titration cell is opened to add the sample, about 50-100 µg water enter the anode compartment, depending on the ambient humidity. With an optimum sample size of 1 mg water/sample, this would lead to an error of 5% to 10%. For this reason, other methods have to be used for the determination of low water content by KF coulometry in solid samples:

- External extraction
- External dissolution
- Drying oven

On the other hand, in a **volumetric KF titrator** solids can be directly transferred into the titration vessel. The sample should be quickly weighed and added to minimize air exposure. If possible, it should be added under *the same conditions* as it was transported and stored. For instance, the storage of samples in a refrigerator may cause water to condense; thus, it is necessary to warm up such samples to room temperature in a closed vessel before weighing.

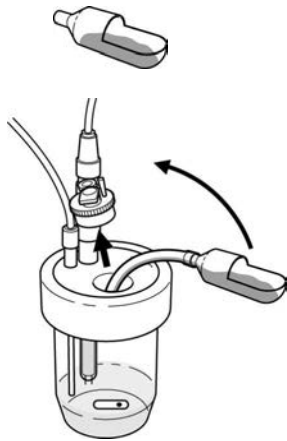
| Sample characteristic                                 | Procedure  |
|---|--|
| <b>Brittle</b><br><b>Hard/soft</b><br><b>Pourable</b> | <i>e.g. salts, crystalline samples:</i><br><b>Weighing boat</b><br>– Grind hard, coarse-grained samples in a closed, cooled analytical mill; pulverize less hard samples in a mortar.<br>– Add the sample with a weighing boat.  |
| <b>Finely powdered</b><br><b>Dusty</b>                | – Use a weighing boat with an attached <i>flexible tubing</i> to add the sample: it prevents the sample from adhering to the wall of the titration vessel or to the electrode.   |
| <b>Finely powdered with very low water content</b>    | <i>e.g. salicylic acid, cellulose powder:</i><br>– Either weigh the sample in a dry box or extract it externally.  |
| <b>Soft</b>   | <i>e.g. jellied fruits, jelly bears, almond paste:</i><br>Cut into small pieces with scissors or a knife and add the sample with a spatula.  |
| <b>Hard, fatty</b>                                    | <i>e.g. chocolate, solid fat:</i><br>– Grate the product and add the sample with a spatula.  |

|  |  |
|--|--|
| <b>Soft, fatty, inhomogeneous</b>      | <i>e.g. butter, margarine, edible fat:</i><br>– Homogenize the sample well: the water is heterogeneously distributed. The water content is often lower at the surface than inside the sample.<br>– Add the sample with a spatula. Do not use a syringe, because the water is released if it is pressurized |
| <b>Waxy</b>                            | <i>e.g. candles, paraffin, ski wax, suppositories:</i><br>– Liquefy the samples in a drying oven at approx. 50 °C and fill them into a syringe.<br><br>The syringe is heated up together with the wax. This prevents the sample from hardening inside the syringe during the weighing process              |
| <b>Creamy</b><br><b>Highly viscous</b> | <i>e.g. chocolate cream, honey, sugar products</i><br>– The METTLER TOLEDO <b>Visco-Spoon™</b> simplifies the handling with creamy samples since it can be directly mounted into the titration stand.  |



### Weight of solid samples with the back-weighing technique

- Weigh the sample in the weighing boat.
- Tare the balance to zero.
- Add the sample into the titration vessel. Use a weighing boat with attached flexible tubing if necessary, to prevent the sample from adhering to the vessel wall or to the electrode.
- Back-weigh the empty weighing boat.
- Enter the weight in the titrator or transfer it automatically.
- Start the titration.

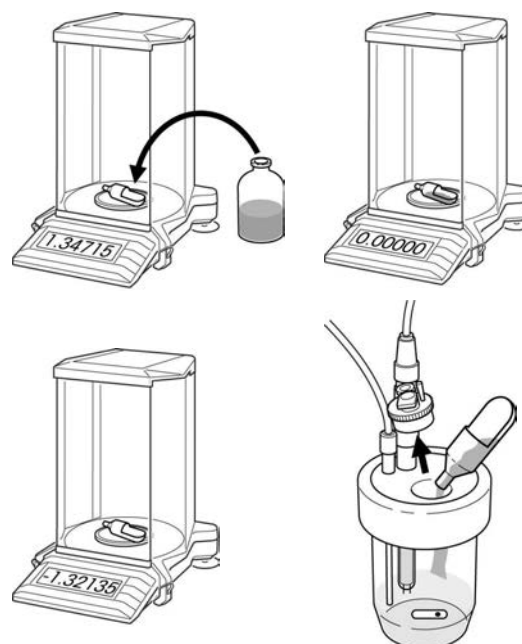

## 7 Release of water from the sample

Karl Fischer titration is only possible if the water in the samples is freely available. This is not the case with solids if the water is bound as, e.g.:

- entrapped water
- water of crystallization (salts).
- water adsorbed on surface
- capillary bounded water (e.g. in plants)

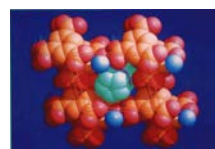
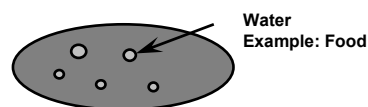

Example: Gypsum  
( $\text{Ca}_2\text{SO}_4 \cdot 2 \text{H}_2\text{O}$ )



Water  
Example:  
Sugar,  
pharmaceuticals



Water:  
Example: Biological  
samples

Thus, suitable sample preparations and special Karl Fischer methods are necessary to release water in these samples.

### Sample preparation

First of all, it is necessary to **crush** insoluble solids in order to gain access to the trapped water. The following methods are available:

| Sample characteristic           | Procedure  |
|---------------------------------|--|
| <b>Very hard</b>                | <i>e.g. minerals, hard salts:</i><br>Grind in a closed, cooled analytical mill.  |
| <b>Hard, brittle</b>            | <i>e.g. inorganic salts, grain, noodles, coffee beans:</i><br>Crush in a mixer.  |
| <b>Moderately hard, brittle</b> | <i>e.g. organic salts, crystalline products:</i><br>Pulverize in a mortar.   |
| <b>Viscous</b>                  | <i>e.g. jellied fruits, almond paste ("marzipan"):</i><br>Cut into small pieces with scissors or a knife.                  |
| <b>Hard, fatty</b>              | <i>e.g. chocolate, solid fat:</i><br>Grate the product.  |
| <b>Soft, fatty</b>              | <i>e.g. sausage, meat, cheese:</i><br>Mince the product, then reduce it further with a homogenizer in an external solvent. |
| <b>Fibrous natural products</b> | <i>e.g. dried fruit and vegetables, berries:</i><br>Reduce with a homogenizer in an external solvent.                      |
| <b>Suspensions</b>              | <i>e.g. fruit juice extracts, vegetable juices:</i><br>Reduce with a homogenizer.  |

## 7.1 Internal extraction

Internal extraction is suitable for **insoluble solids** that release water **quickly** when crushed:

- Add the crushed samples into the titration vessel, using either methanol or a mixture of it as the solvent.
- Water is then extracted providing the mixing time defined in the titration method is sufficiently long.

You can speed up the extraction of water from the sample by

- heating the solution with a thermostating titration beaker,
- grinding the sample additionally with a built-in homogenizer (see photos below).

In many cases, the homogenizer eliminates the need to use auxiliary reagents such as formamide with, e.g. hazelnuts, potato chips, sugar, etc.



Thermostatable vessel



High-speed homogenizer

Examples:

| Sample                  | Result / % | srel / % | Solvent                         |
|-------------------------|------------|----------|---------------------------------|
| Flour                   | 12.1       | 0.4      | Formamide:methanol 2:3 at 50 °C |
| Potato chips            | 4.8        | 0.8      | Formamide:methanol 2:3 at 50 °C |
| Ground hazelnuts        | 4.8        | 1.2      | Formamide:methanol 2:3 at 50 °C |
| Chocolate               | 1.3        | 1.1      | Methanol / Homogenizer          |
| Instant coffee          | 2.5        | 1.4      | Methanol / Homogenizer          |
| Dried chives            | 8.0        | 1.0      | Methanol / Homogenizer          |
| Dried tarragon          | 7.3        | 1.4      | Methanol / Homogenizer          |
| Aspirin                 | 1.5        | 1.9      | Methanol / Homogenizer          |
| Sweetener tablets       | 1.1 mg/pc  | 0.9      | Methanol / Homogenizer          |
| Optical bleaching agent | 3.9        | 0.8      | Methanol                        |

## 7.2 External extraction

External extraction is suitable for **insoluble solids** that release water only **slowly** when crushed as well as for samples with an extremely **inhomogeneous water distribution**. In particular, water is extracted from the sample by means of a defined quantity of solvent of known water content.

Briefly, the finely crushed sample is added to a solvent with **very low** water content and is left to stand until the water has been released from the sample. The extraction of water can be improved

- by shaking the solution (mechanical shaker, shaking bath)
- placing the solution in an ultrasonic bath for a certain time
- or reducing the sample further with a built-in homogenizer.

The organic solvents most commonly used are:

- methanol for insoluble organic solids
- decanol / octanol for fatty and dairy products (butter, butter milk, edible fat)
- formamide for natural substances (almonds, pepper, curry)  
for dehydrated products  
for sugar (total water), sugar and starch products
- chloroform for sugar (surface water)

The external extraction is carried out in four steps:

### Step 1: Blank value determination of the extraction solvent

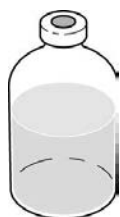

Solvent in septum bottle

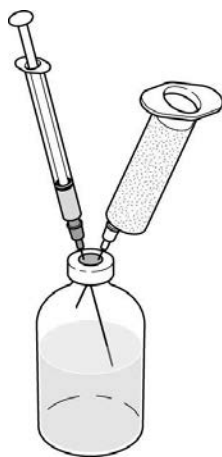

Take a solvent aliquot

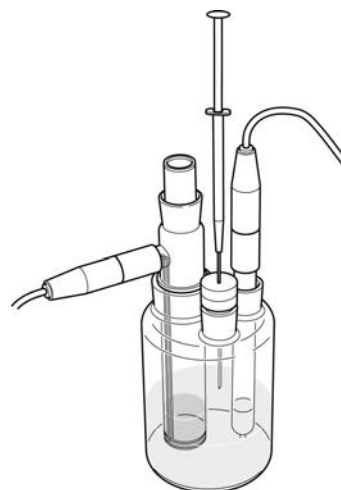

Water content determination  
of solvent = **blank value B**

- The water content of the solvent must be **much less** than the one of the sample.
- Pay attention to the water capacity of chloroform (max. 350 ppm) and toluene (max. 600 ppm).
- Provide sufficient solvent for the blank value determination so that enough solvent is available for the extraction.

**Step 2: Weigh in solvent and sample**

Weigh solvent in = **msolv**

Add sample

Weigh sample = **mext**

- Cut the sample into small pieces so that it releases its water more quickly and efficiently.
- Add a *sufficient* amount of sample. The larger the sample, the smaller the relative error because the total error is calculated with respect to the sample size.
- A dilution factor of **10 - 20** is normally used.

**Step 3: Extraction**

- Shake, or use an ultrasonic bath with heating, or use a homogenizer.
- Shaking is the method generally used for extraction.
- A mechanical shaker is normally used because the extraction time is often long (at least two hours or overnight).
- For the extraction of tablets, the addition of **dry quartz sand** has proven useful for improving and speeding up the extraction.



**Step 4: Allow settling, take an aliquot and titrate**

Allow to settle

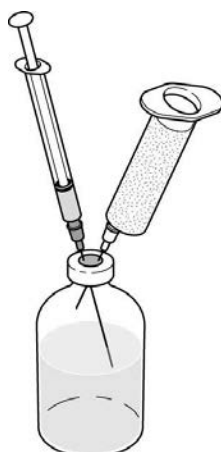

Take an aliquot of the extraction solution

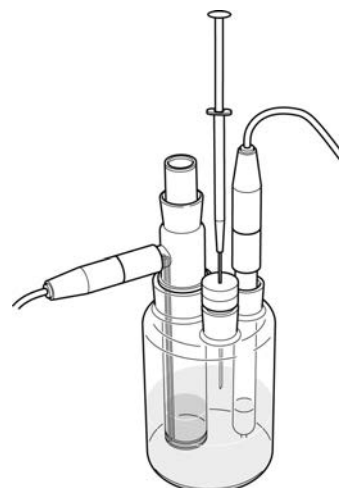

Titrate sample

The following equations are used to calculate the water content of the extracted sample:

**For % :** 
$$R(\%) = \frac{100}{100 - C} \cdot \left( C \cdot \frac{msol}{mext} - \frac{B \cdot msol}{mext} \right)$$

**For ppm :** 
$$R(ppm) = \frac{10^6}{10^6 - C} \cdot \left( C \cdot \frac{msol}{mext} - \frac{B \cdot msol}{mext} \right)$$

**R:** Water content in the sample P (% or ppm).

**C:** Water content of the supernatant extraction solvent (% or ppm)

%:  $C = (VEQ \cdot CONC - TIME \cdot DRIFT / 1000) \cdot 0.1 / m$

ppm:  $C = (VEQ \cdot CONC - TIME \cdot DRIFT / 1000) \cdot 1000 / m$

**B:** Blank value (water content of the solvent, % or ppm).

**msol:** Amount of solvent (g)

**mext:** Amount of sample (g) extracted with the solvent

**m:** Weight of the sample aliquot (g)

Note:

The detailed calculations which lead to these formulas are given in the appendix.

Examples for the external extraction:

### KF Coulometry

| Sample                     | Result / ppm | srel / % | Extraction solvent |
|----------------------------|--------------|----------|--------------------|
| Sucrose<br>(surface water) | 72           | 4.2      | Chloroform         |

### Volumetric KF Titration

| Sample        | Result / % | srel / % | Extraction solvent               |
|---------------|------------|----------|----------------------------------|
| Cheese        | 27.6       | 0.4      | Decanol:formamide:methanol 8:2:1 |
| Liver sausage | 61.6       | 0.4      | Decanol:formamide:methanol 8:2:1 |
| Mustard       | 72.4       | 0.6      | Decanol:formamide 1:1            |
| Chicken broth | 4.9        | 0.3      | Decanol:formamide:methanol 8:2:1 |
| Tobacco       | 11.5       | 0.5      | Methanol                         |
| Wool          | 9.8        | 0.4      | Methanol                         |
| Acrylic paint | 54.3       | 0.5      | Formamide                        |

There is a dedicated KF method type 'External Extraction'. The METTLER TOLEDO methods M305 for the volumetric KF titrator and M394 for the coulometric KF titrator are available with optimized method parameters for immediate execution.

The solvent blank is determined directly from the method running in standby by pressing the 'Start blank' button.

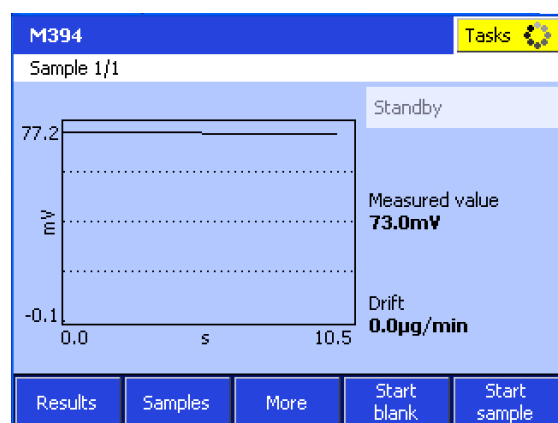

The weight of the solvent (msol), the weight of the sample (mext) and the weight of the aliquot of the supernatant solution containing the extracted water (sample size m) is entered into the respective sample data fields:



| Sample 1/1                |          | Tasks              |
|---------------------------|----------|--------------------|
| Sample list » Sample data |          |                    |
| Number                    | 1        | i ↑                |
| ID 1                      | --       | A <sub>B</sub> C   |
| Sample size               | 0 g      | 1 <sub>2</sub> 3   |
| Density                   | 1.0 g/mL | 1 <sub>2</sub> 3   |
| Solvent weight            | 0.0 g    | 1 <sub>2</sub> 3   |
| Wt. extracted sample      | 0.0 g    | 1 <sub>2</sub> 3 ↓ |
| Cancel                    |          | OK                 |

The equation for the calculation of the water content of the extracted sample is predefined in the calculation method function. In particular, by selecting the appropriate calculation (i.e. "External extraction") in the method function "Calculation", the formula is automatically given.

*Note:*

1. The water content of the solvent should be *as low as possible*, in order to maximize the extraction effect and ensure that the difference between the water contents before and after extraction is as large as possible.
2. The amount of sample should be *sufficiently large* to ensure that the amount of water in the sample is significantly greater than that in the solvent prior to extraction.
3. The amount of sample should also take account of the absorption capacity of the solvent. Chloroform, for instance, reaches the saturation limit for water already at 350 ppm!

### 7.3 External dissolution

External dissolution is defined as the **complete dissolution** of a sample in a defined amount of solvent of known water content. External dissolution is suitable for soluble solids

- with an extremely inhomogeneous water distribution, or
- with a very low water content, or
- with a high water content

Pure solvents can be used to dissolve the samples; the addition of methanol is not necessary. The following solvents are commonly used:

- methanol for organic solids
- formamide for sugar products
- chloroform for petroleum oils and adhesives
- toluene for tar, waxes and suppositories

Example:

| Sample                                | Result / ppm | srel / % | External solvent |
|---------------------------------------|--------------|----------|------------------|
| Sucrose<br>(total water)              | 533          | 4.2      | formamide        |
| Naphthalene                           | 35           | 10.2     | methanol         |
| Phenol                                | 174          | 1.8      | methanol         |
| Salicylic acid                        | 116          | 2.9      | methanol         |
| Contact adhesive<br>("Rubber cement") | 278          | 5.3      | chloroform       |

The method corresponds to external extraction except that the sample dissolves completely in the external solvent. The dedicated method type 'External Extraction' and the METTLER TOLEDO methods M305 for the volumetric KF titrator and M394 for the coulometric KF titrator can be used as templates; only the calculation method function has to be adapted to by selecting the corresponding calculation from the list of proposed results.

For % **AND** ppm: 
$$R(\%, ppm) = C \cdot \left( \frac{msol + mext}{mext} \right) - \left( \frac{B \cdot msol}{mext} \right)$$

**R:** Water content in the sample P (% or ppm)

**C:** Total water content (sample + solvent), in % or ppm.

%:  $C = (VEQ \cdot CONC - TIME \cdot DRIFT / 1000) \cdot 0.1 / m$

ppm:  $C = (VEQ \cdot CONC - TIME \cdot DRIFT / 1000) \cdot 1000 / m$

**B:** Blank value (water content in % or ppm) of the solvent.

**msol:** Amount of solvent (g) after determining the blank value

**mext:** Amount of sample (g) extracted with the solvent

**m:** Weight of the sample aliquot (g)

To obtain accurate results a large sample amount is used for substances with an inhomogeneous water distribution. Direct titration is not suitable, because a large sample amount leads to a too long titration time, and too much titrant is consumed.

If the solid has a low water content (<200 ppm), the error obtained by direct titration if the titration stand is opened to add the sample is too large. If 1 g of sample has a water content of 100 ppm (= 100 µg) for instance, the error as a result of opening the titration stand will be between 10 and 30 µg. Since you are able to work with larger amounts of sample when working with this technique, this error is reduced.

On the other hand, KF coulometry is not suitable for samples with water contents of 10-100% because a very small amount of sample would have to be used. Thus, the sample is previously diluted through external dissolution to be able to titrate a larger sample aliquot.

## 7.4 Lyophilized substance in septum bottles

The extremely low water content of freeze-dried substances (e.g. biological tissue, serum, foodstuffs) in septum bottles means that external extraction or external dissolution as described in the previous sections are not recommended.

In fact, the blank value correction is too large compared to the amount of water in the sample. You should therefore proceed as it follows:

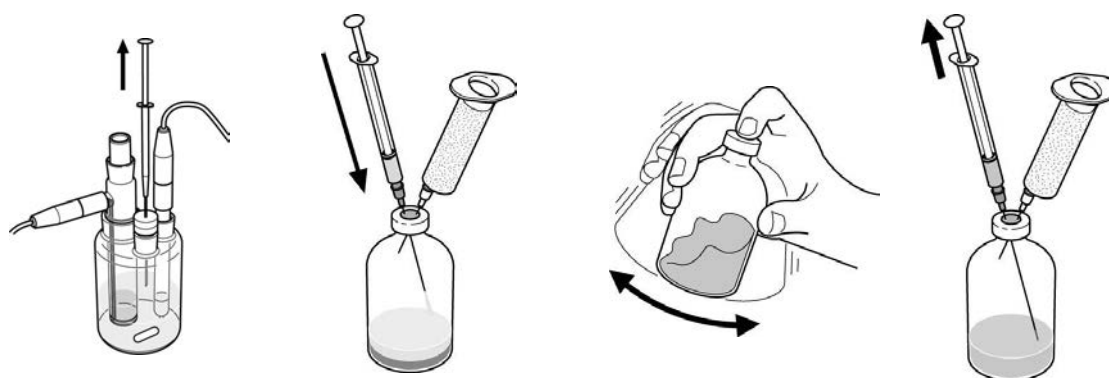

Take an aliquot of analyte

Inject it in the septum bottle

Shake

Take aliquot and titrate

### Procedure:

1. Remove approx. 10 mL of analyte titrated to dryness from the titration cell using a 20 mL syringe with a long needle and then return it to the titration cell.
2. Rinse the syringe two or three times in this way.
3. Draw 10 - 20 mL of analyte titrated to dryness into the syringe, weigh it and inject it into the septum bottle.
4. Determine the weight of analyte injected by back weighing.
5. Shake the bottle or place it in an ultrasonic bath for 5 minutes so that the lyophilized substance dissolves or forms a suspension.
6. Draw an aliquot into the same syringe again, weigh it and inject it into the titration cell.
7. Determine the weight by back weighing.

If the sample is *completely dissolved*: use the method type "External extraction" and the calculation for the "External dissolution"

If a *suspension* is formed: use the method type "External Extraction" and the calculation for the "External extraction"

Note:

In both cases, zero must be entered for the blank value (B), because the analyte titrated to dryness has a blank value of "0".

**Alternative procedure:**

1. Remove approx. 10 mL of analyte titrated to dryness from the titration cell using a 20 mL syringe with a long needle and then return it to the titration cell.
2. Rinse the syringe two or three times in this way.
3. Draw exactly 20 mL of analyte titrated to dryness into the syringe and inject it into the septum bottle. The accuracy of a plastic syringe is enough.
4. Shake the bottle or place it in an ultrasonic bath for 5 minutes so that the lyophilized substance dissolves or forms a suspension.
5. Draw exactly 5 mL from the septum bottle into the same syringe again and inject it into the titration cell. The water amount in  $\mu\text{g}$  is determined.
6. With a standard method calculation and calculate the water amount in  $\mu\text{g}$ .
7. Since  $\frac{1}{4}$  of the total amount was injected, the water amount in the septum bottle is 4 times larger. Thus, the final result must be multiplied by 4 (factor  $f = 4$ ).
8. If you know the lyophilized sample amount in the septum bottle, then you can additionally calculate the result can be given in ppm.

In this way, neither the calculation for the external extraction nor for the external dissolution are needed for this procedure using the volume instead of the mass.

## 7.5 Determination of water in gases

To determine the water content of gases, the gas must be directed through the titration vessel for a defined period of time.

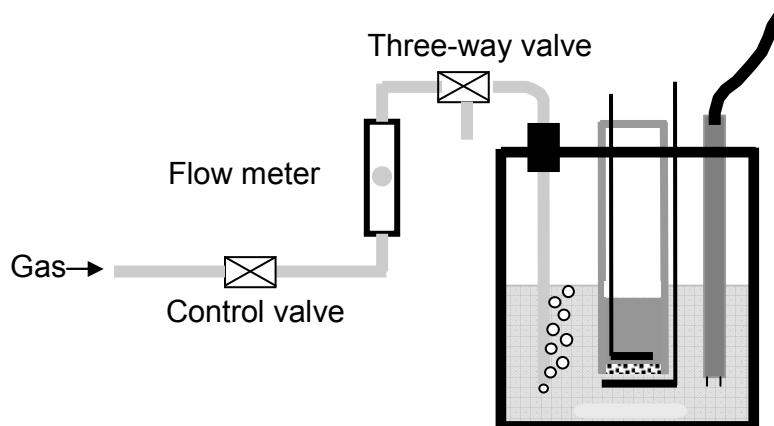

The flow rate has to be constant to determine the volume necessary to calculate the water content:  $\text{gas volume} = \text{gas flow rate} \times \text{time}$ .

The water content in ppm is calculated by entering the volume and the density.

### Sampling/sample addition

- If possible, you should titrate the gas sample directly from the source. If not, you must fill the gas either into special gas sample tubes or into small steel cylinders.
- Purge the sample vessel and the tubings thoroughly beforehand with the gas.
- With sample vessels the gas amount gas can be determined by differential weighing.

### Determination

- Adjust the gas stream to a constant flow rate with the control valve: 50 to 200 mL/min, depending on the water content of the gas.
- Purge the system with the gas before you start the determination.
- Turn the three-way valve, to prevent the gas from flowing into the titration vessel.
- As soon as the drift is stable again, start the titration and reset the three-way valve to its original position in order to direct the gas into the titration vessel.
- Stop the gas flow after 1 to 2 mL titrant has been consumed.
- Calculate the volume from the time and the gas flow rate.

### Notes

- Add a sufficient amount of buffer solution into the titration vessel to determine the water content of *acid gases* such as e.g. hydrochloric acid.
- When titrating large quantities of gas in the same solvent, evaporated methanol lost in the gas stream must be replaced depending on titration time and number of determinations.
- CO<sub>2</sub> gas can not be titrated directly since iodine reacts with CO<sub>2</sub>. The gas must be directed through a water-dissolving, water-free absorption liquid in which CO<sub>2</sub> itself does not dissolve. The water contained in the gas is then absorbed by the liquid and can be determined by means of Karl Fischer titration in a process similar to external extraction.
- Select "*Max. time*" and a "*Delay time*" of e.g. 600 s as termination parameters, to ensure that the titration is **terminated** after the maximum time.

## 7.6 Determination using the drying oven

This method is suitable for *solids* and *liquids* that

1. cause side reactions with the Karl Fischer reagent,
- or
2. that release water very slowly.

### 7.6.1 Principle

The sample is heated in an oven, causing the water in the sample to vaporize. The water is transferred to the titration cell in a current of dry inert gas (purge gas), and the amount of water is determined.

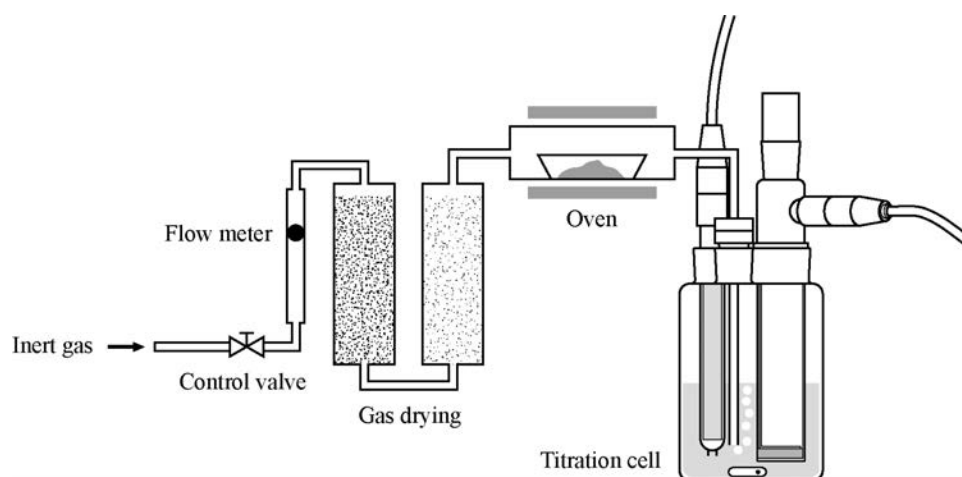

### 7.6.2 Purge gas

- Air contains oxygen, which could react with the sample at higher temperatures. Air should therefore *only* be used for *non-oxidizable, inorganic samples*.
- If you use air for organic samples, the oven temperature should not exceed 160 °C.
- If you use nitrogen from a gas cylinder, you should use a two-stage pressure regulator so that the final pressure is in the range 0.5 - 1 bar (cf. chapter 7.6.4)
- A gas stream of approx. 150 mL/min is ideal for DO308 and 70 mL/min for Stromboli (automated KF drying oven, cf. chapter 7.6.5). Experiments with various gas flow rates yielded the following results:

|                                |      |      |      |
|--------------------------------|------|------|------|
| <b>Gas flow rate [mL/min]:</b> | 108  | 166  | 500  |
| <b>Recovery [%]:</b>           | 99.9 | 99.7 | 97.1 |

- The recovery rate is **clearly decreasing** with **increasing** gas flow rate. Thus, for accurate results do not select a too high gas flow rate.
- The purge gases commonly used contain moisture, e.g.:
  - air with 50% humidity: approx. 11 mg/L
  - nitrogen gas from a cylinder: 1.4 – 8.0 mg/L

Therefore, the purge gases must be **first dried** before entering the KF oven. For Karl Fischer titration, the residual moisture in the purge gas should be less than at least 10 µg/L (for coulometric determination) and 20 µg/L (for volumetric KF titration) in order to obtain accurate and repeatable results.

Several agents are available to dry the purge gas:

| Method   | Residual moisture             | Residual moisture for 200 mL/min gas flow rate (drift) |
|--|-------------------------------|--|
| Sulfuric acid, 100%                                  | 50 - 80 µg H <sub>2</sub> O/L | 10 – 15 µg H <sub>2</sub> O/min                        |
| Phosphorous pentoxide, P <sub>2</sub> O <sub>5</sub> | 40 - 50 µg H <sub>2</sub> O/L | 8 – 10 µg H <sub>2</sub> O/min                         |
| KF one-component reagent                             | 15 – 20 µg H <sub>2</sub> O/L | 3 – 4 µg H <sub>2</sub> O/min                          |
| Silica gel   | 50 – 60 µg H <sub>2</sub> O/L | 10 – 12 µg H <sub>2</sub> O/min                        |
| Molecular sieves 3 Å                                 | 5 – 10 µg H <sub>2</sub> O/L  | 1 – 2 µg H <sub>2</sub> O/min                          |

You can use the following desiccants to dry the purge gas:

- *Molecular sieves* are the best drying agent as far as residual moisture is concerned, but their water absorption capacity is low, i.e. they are rapidly exhausted.
- *Silica gel* is appreciably better in this respect. It is therefore recommended to dry the gas with a combination of silica gel and molecular sieves. Start off with the silica gel to absorb the bulk of the water and then use molecular sieves to reduce the residual moisture to a minimum.

Silica gel and molecular sieves have the advantage that they can be regenerated, in contrast to other desiccants. Silica gel can be regenerated over night at 150 °C, whereas molecular sieves requires temperatures up to 300 °C.

### 7.6.3 Procedure

There are *two different methods* to perform a KF titration with the drying oven:

#### 1. Method 1: The water evolved is continuously titrated

After a short mix time (20 - 60 s), the titration starts and the released water is continuously titrated. The short mix time is necessary so that a delayed vaporization of water does not lead to premature termination of the titration. In order to avoid the latter you may also use the minimum time as termination parameter.

At the end of the titration, the vaporization is often very irregular. To ensure that the determination is repeatable, you should set the *maximum titration time* as the termination parameter (i.e. deactivate the drift stop).

#### 2. Method 2: The water is first vaporized and then titrated afterward

During a defined long mix time, all the water is vaporized and transferred to the titration cell. The KF titration is then started. The relative drift stop or the maximum titration time can be used as the termination criterion.

With some samples the drift at the end of the titration is significantly higher than the initial drift. This is caused by a slow release of the final traces of water or slow thermal decomposition of the sample. In such cases you should use the *maximum titration time* as termination parameter (i.e. deactivate the drift stop).

Passing the gas stream into the titration cell causes the anolyte (in the KF coulometer) and solvent (generally methanol in KF volumetric titrator) to vaporize, especially methanol. The amount depends on the gas flow rate and the type of KF reagent present in the titration cell.

In the case of KF coulometers, there are two types of anolyte solutions:

- Standard anolyte solutions containing methanol (e.g. Coulomat AG or CombiCoulomat frit):  
Anolyte loss at **150 - 200 mL/min**, oven temperature **200 °C**: **approx. 3,5 - 4,5 mL/hour**
- Anolyte containing ethylene glycol, i.e. dedicated anolyte to be used with a KF Oven (e.g. Coulomat AG Oven):  
Anolyte loss at **150 - 200 mL/min**, oven temperature **200 °C**: **approx. 1 mL/hour**

From time to time, you should replace the anolyte lost through vaporization with new anhydrous methanol. Make sure that the level of the anolyte does not fall below that of the catholyte (higher drift!).

Due to the *vaporization of the methanol*, there is a small loss of water, i.e. the recovery is not 100%. The recovery therefore depends on the amount of methanol vaporized and the method used. As an example data from coulometric determinations are indicated here below:

| Method | Anolyte          | Gas flow rate | Recovery / % |
|--------|------------------|---------------|--------------|
| 1      | Coulomat AG      | 166 mL/min    | 99.7         |
| 1      | Coulomat AG Oven | 183 mL/min    | 99.95        |
| 2      | Coulomat AG      | 166 mL/min    | 98.2         |
| 2      | Coulomat AG Oven | 106 mL/min    | 99.1         |

Briefly:

*The less methanol is vaporized, the faster the water is titrated, and the better the recovery.*

#### 7.6.4 Manual Karl Fischer drying oven

The METTLER TOLEDO DO308 drying oven can be operated in a temperature range from 50 to 300 °C. It has a large glass sample boat capable of holding up to 10 cm<sup>3</sup> of sample. This is particularly important with low-weight samples (e.g. fibers) or with samples of low water content.

The DO308 oven is equipped with a gas drying unit with two bottles for silica gel and molecular sieve, as well as a gas flow meter. An air pump is available as an optional accessory.

The procedure for the determination of water content is described in the operating instructions.

Examples:

| Sample       | Result / ppm | No. of samples | srel / % | T / °C | Time/min | Comments  |
|--------------|--------------|----------------|----------|--------|----------|-----------|
| Polyamide    | 5547         | 6              | 0.8      | 190    | 15       | Max. time |
| Polyethylene | 68           | 6              | 6.9      | 280    | 10       | Max. time |
| Motor oil    | 842          | 6              | 9.9      | 140    | 15       | Max. time |
| Cement       | 8200         | 6              | 2.2      | 300    | 20       | Max. time |
| Cooking salt | 360          | 5              | 4.2      | 300    | 10       | Max. time |
| Carbon black | 3583         | 5              | 1.5      | 200    | 15       | Max. time |



## Comments:

1. Set a gas flow rate of 150-200 mL/min.
2. Always start the titration *before* you place the sample in the oven to ensure that the correct drift value is adopted by the method (online drift).
3. The drift should be **5-10 µg H<sub>2</sub>O/min** at a gas flow of 150 mL/min. If the drift is *higher* than 15 µg H<sub>2</sub>O/min, replace the silica gel and molecular sieves of the gas drying unit, and/or replace the anolyte of the KF coulometer.
4. *Coulometer KF*: The internal drying tube of the generator electrode has to be replaced with an external, bent drying tube. Then, evaporated solvent does not condense in the drying tube, and does not drop into the cathode compartment/ titration cell.
5. Some samples require some time before water starts evaporating. Here a *short mixing time* (15 to 60 s) or the minimum titration time should be defined to prevent the titration from being terminated too early. For the same reason, do not select the parameter "Auto start".
6. Some samples have *surface water* that is lost as soon as the oven is purged with dry gas. This leads to a too low result. In such cases, you should proceed as follows:
  - Open the stop cock, purge the "cold zone",
  - Close the stop cock and purge the "hot zone".
  - If the drift is constant, start the titration so that the drift value is automatically entered.
7. Add the sample through the tapered joint and slide the glass boat with the sample into the oven:

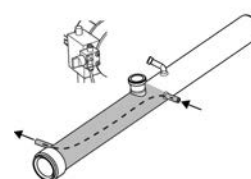

Cold zone or back purging

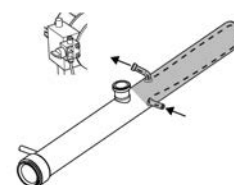

Hot zone or cell purging

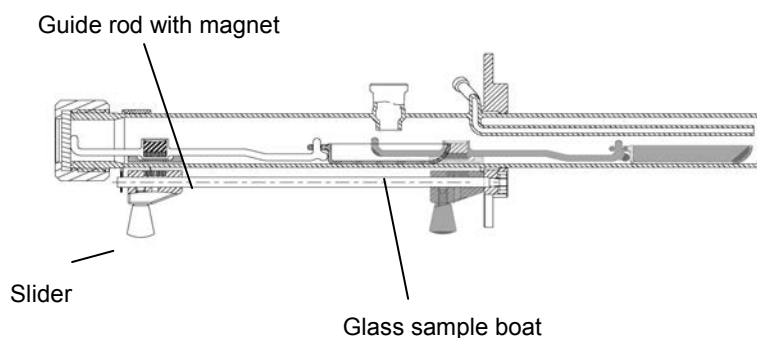

8. To check the performance of the titrator/drying oven system, you may use the SIGMA-ALDRICH HYDRANAL® water standard KF oven 5.55% or VWR/VWR/MERCK water standard KF oven 1%.
9. A large amount of evaporated water cannot be fully absorbed by the solvent. This can happen when the titration is started only after complete evaporation. Experiments using methanol as the solvent gave a recovery rate of 98% for a stream of 166 mL/min. If the water is titrated as soon as it begins to evaporate, the recovery increases to 99.7%.
10. If several determinations are performed in the same solvent, the evaporated solvent lost in the gas stream has to be replaced. For instance, in volumetric KF titration the methanol loss is approx. 3.5 to 4 mL/h for an oven temperature of 200 °C and a flow rate of 200 mL/min. The evaporation is reduced by adding ethylene glycol (higher boiling point) to a maximum solvent ratio of 20-30%.

### 7.6.5 STROMBOLI automatic oven sample changer

The METTLER TOLEDO STROMBOLI oven sample changer is a drying oven for automatic Karl Fischer titration with the KF Compact Volumetric V30 and Coulometric Titrators C30 as well as with the Titration Excellence Titrators T70 and T90.

The drying oven can be operated in the temperature range from 50 to 300°C. STROMBOLI is completely controlled by the titrator: all the parameters for the determination, including the oven temperature, are included in the titration method.

Besides 14 places for glass sample vials, STROMBOLI offers one fixed place on the sample rack for an empty sample vials in order to determine the drift value.

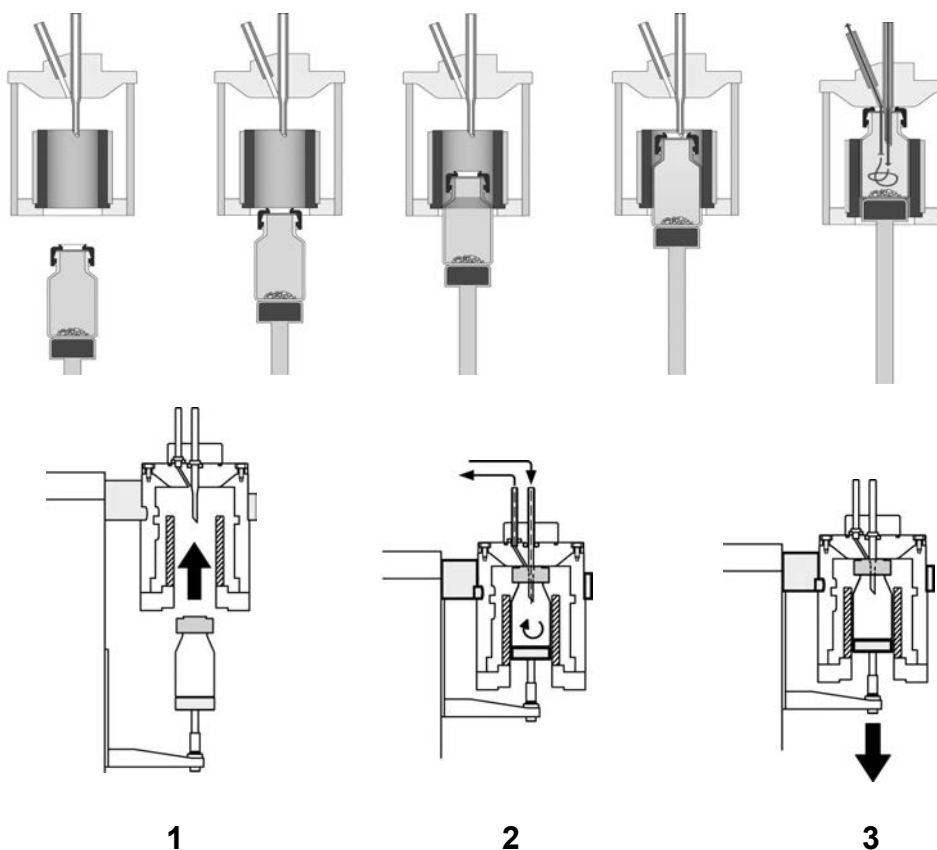

#### During a sample series:

1. The sample vials are moved upward into the oven by a lift. The blue rubber cap seals the sample vial tightly against the oven, while a glass tube pierces the aluminum foil cover. The oven heats the sample to the set temperature.
2. The purge gas flows through the sample vial and the water vaporized is transported via the transfer tube into the titration cell of the coulometer.
3. After the analysis, the lift is moved downward and gravity facilitates the removal of the sample vial from the oven.

**Sample vials:**

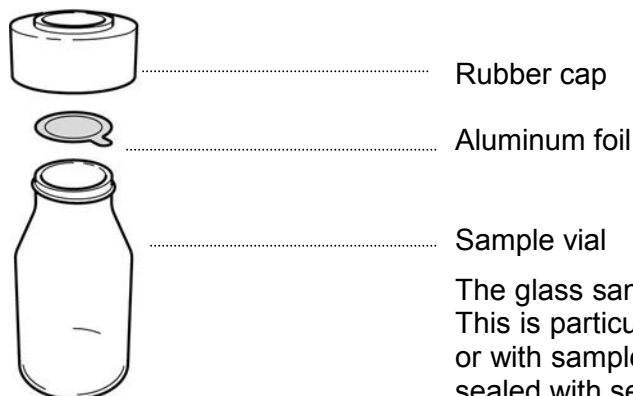

The glass sample vials have a large volume (up to 25 mL). This is particularly important with light samples (e.g. fibers) or with samples of low water content. The sample vials are sealed with self-sealing aluminum foil and a rubber cup.

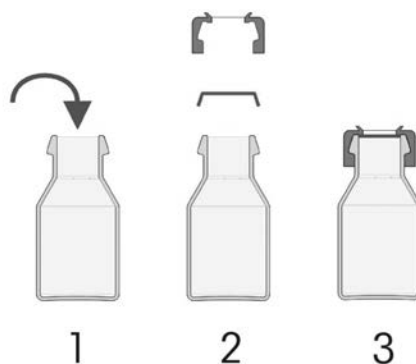

**Drift determination:**

The drift determination is performed with an empty vial on the first position of the sample rack. The drift value is defined as the moisture entered into the titration cell by the purge gas.

To determine the drift value accurately, the moisture in the empty sample vial has first to be removed. This takes 10-20 minutes as can be seen in the following diagram:

**Drift at 180 - 300 °C / 150 mL/min**

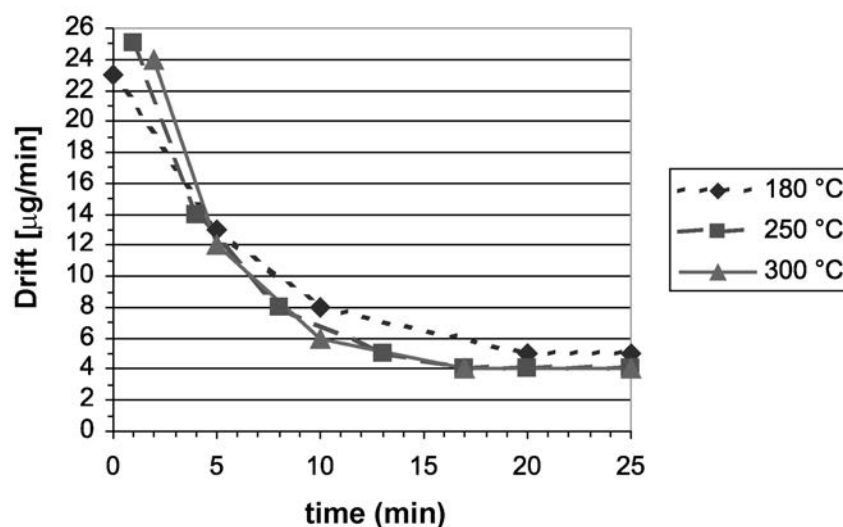

**Blank value determination:**

The blank value is the amount of water contained in an empty sample vial (i.e. the moisture in the air present in the vial, and the adsorbed moisture on the glass walls of the vial) minus the amount of water due to the drift (i.e. drift value x time).

The blank value should be determined before *each series* because the humidity can change, and thus the moisture adsorbed on the glass walls is not always the same.

The **optimum blank value** is in the range of **70 - 300 µg water**.

*Important:*

After a blank value determination, the vial used no longer has the same properties as the "fresh" sample vials, i.e. the moisture content is somewhat lower. Thus, it is important to use a new sample vial for each blank value determination (i.e. one with the same properties as the sample vials into which the samples have been filled in).

**Performing the drift and blank value determination**

In general, a blank value determination should be performed **before** each series of samples since the ambient conditions (humidity, moisture in the sample vial, gas flow, etc.) are always slightly different.

If the **maximum titration time** is used as termination criterion in the method -which is what we recommend- the analysis times for the *determination of the blank value* and for *each sample* are the same. In this case, the blank value determination also takes the actual drift into account. It is therefore not necessary to perform a drift determination before each series. This means that the stored drift value of the previous determination will be used.

Nevertheless, a drift determination should still be performed *at least once a day* in order to check whether the drift is too high (e.g. > 15 µg H<sub>2</sub>O/min). If this is the case, the silica gel and molecular sieves in the bottles of the gas drying unit can be replaced, as well as the anolyte in a coulometric analysis.

**Multiple sample series at different temperatures**

Several series can be started on the same sample turntable – even at different temperatures. If, for example, different plastic samples have to be analyzed, whose optimum bake-out temperatures differ, they can be measured at different temperatures using the same method. For each series, the method contains a so-called sample loop. At the start of the method, you can enter the number of samples the series includes for each loop. The loops run through one after the other and the samples are processed sample for sample. If the temperatures of successive loops are different, the last sample vial that was baked out remains in the oven until the temperature has stabilized at the temperature of the next loop and the drift is low and stable. The first sample of the next loop is then transferred into the oven and the water determination begins. There are dedicated METTLER TOLEDO multi-loop methods available in the V30 (M313) and in the C30 (M396). These method templates are based on a dedicated KF method type called 'Stromboli'.

The blank value can also vary as a function of temperature. In this case, a blank determination can be performed between two sample loops. The new blank value is automatically used for the blank correction. To determine the blank value as accurately as possible, several blank value determinations can be performed one after the other in the same loop and the mean value calculated from the results. In the same way, at the end of a series the blank value can be measured again and compared with the value determined at the beginning.

With rapidly changing, suboptimum conditions, the drift value can change with time. By performing a drift determination at the end of the series or between several series, you can check whether the drift is constant and the new drift value can be used for the next series.

**Comments on the operation with the STROMBOLI oven sample changer:**

1. Set a gas flow of 40–60 mL/min. The delivery tube has a T-piece that causes a small leak flow. This is necessary so that the KF solvent or analyte is not aspirated into the hot sample vial if Stromboli is not properly shut down while it is still hot.
2. An optional 3/2 way valve which is automatically controlled by STROMBOLI can be used instead of the T-piece mentioned in 1. This valve shall be used especially if inert gas sources are used, since it provides a leak free inert gas stream during normal operation. A sudden shutdown of power immediately switches the valve in that way, that the inert gas stream to the gas source is closed and the system is ventilated with ambient air. Therefore no precious inert gas is lost and no vacuum is applied to the system which may result in a back aspiration of the analyte into the hot oven.
3. *KF Coulometer C30*: The internal drying tube of the generator electrode has to be replaced with an external, bent drying tube. In this way, evaporated solvent is not condensing in the drying tube, and therefore it does not drop into the cathode compartment.
4. With STROMBOLI, you can not only determine solids but also liquid samples. These are partially vaporized (e.g. motor oil) or completely vaporized (e.g. toluene, see also list of results). A special (longer) gas inlet glass tube is provided to bubble gas into the liquid.
5. The amount of moisture adhering to the glass surface of the sample vials strongly depends on how the vials were treated beforehand (cleaning, drying and storage). This has a large effect on the blank value and thus on the result. Vials that have undergone different treatment can show differences in the blank value of 50-150 µg water.
6. Use the same vials for a sample series as well as for the blank value determination.
7. Allow sample vials that have been used or cleaned to stand overnight in the atmosphere for conditioning before starting measurements.
8. To check the titrator/drying oven system, you can use SIGMA-ALDRICH HYDRANAL® water standard KF oven 5.55% or VWR/VWR/MERCK water standard KF oven 1%. This test also serves to check the tightness of the oven and the connection tubing

Examples:

| Sample                             | Result [ppm] | No. of samples | srel [%]   | T [°C]                          | Max.Time [s] | Comments   |
|------------------------------------|--------------|----------------|------------|---------------------------------|--------------|--|
| Polylactic acid<br>0.5 g           | 2589         | 3              | 1.1        | 160,<br>air                     | --           | Stir time: 600 s<br>Max. time: 300 s<br>rel. drift: 3 µg/min   |
| Polymer<br>ABS-50 T 10014<br>3 g   | 736          | 5              | 1.1        | 190,<br>N <sub>2</sub> -<br>gas | 300          | Stir time: 900 s<br>Delay time: 300 s  |
| Polymer<br>ABS-50 F10014<br>2 g    | 1312         | 13             | 0.9        | 170,<br>N <sub>2</sub> -<br>gas | 300          | Stir time: 900 s<br>Delay time: 300 s  |
| Motor oil<br>1120/03 (AA)<br>2 g   | 241<br>261   | 3<br>4         | 4.4<br>7.9 | 165,<br>air                     | 1500         | Stir time: 60 s<br>Delay time: 300 s<br>Very slow evaporation,<br>not faster with 180°C,<br>above 180°C<br>decomposition |
| Motor oil<br>1034/03 (AA)<br>1.5 g | 426<br>438   | 4<br>3         | 2.7<br>4.5 | 180,<br>air                     | 1800         | Stir time: 60 s<br>Delay time: 300 s<br>Very slow evaporation,<br>above 180°C<br>decomposition                           |

## 8 Measurement results

### 8.1 Resolution and detection limit

The following table indicates the *theoretically smallest* increments of current (KF coulometric) and titrant (Volumetric KF) which could be achieved by the instruments based on their technical specifications. Therefore, these are indicative values and they should be considered as such:

|  | <b>C20/C30<br/>Compact Coulometric Instrument</b>  | <b>V20/V30<br/>Compact Volumetric Titrator</b>   |
|--|--|--|
| Theoretical smallest increment               | <b>0.1 mC</b> (100 mA x 1 ms)<br>Theoretical: 0.01 µg H <sub>2</sub> O<br>Resolution: < 0.1 µg H <sub>2</sub> O  | <b>Resolution: 20'000</b> burette steps<br>5 mL burette: <b>0.25 µL</b><br>c=5 mg H <sub>2</sub> O/mL: <b>1.25 µg H<sub>2</sub>O/step</b>                                  |
| Detection limit<br>(limit of detection, LOD) | <b>10 µg</b><br>Example:<br>10 g sample → determ. of <b>1 ppm</b><br>Assumptions:<br>- Current is used for iodine generation<br>- Generated iodine is reacting 100% with water only. | <b>50 x resolution</b><br>5 mL burette: <b>12.5 µL</b><br>c=5 mg H <sub>2</sub> O/mL: <b>62.5 µg H<sub>2</sub>O</b><br>Example:<br>5 g sample → determ. of <b>12.5 ppm</b> |

The theoretically smallest current increment that can be generated by the C20/C30 Compact Coulometers is 0.10712 mC which corresponds to 0.01 µg water. However, the achievable resolution of the instrument is in the order of less than 0.1 µg H<sub>2</sub>O, whereas the detection limit (also called “limit of detection”) is approx. 10 µg water per sample. Thus with a 10 g sample, 1 ppm water can be determined.

For the V20/V30 Compact Volumetric instruments, the detection limit mainly depends on

- The resolution of the burette drive, i.e. the max. number of steps which can be achieved by the stepper motor.
- the burette volume size; generally, a 5 mL burette is used for volumetric KF titration.
- The concentration of the titrant.

### 8.2 Measurement accuracy

The accuracy strongly depends not only on the technical specifications of the instruments, but also on the several factors that have been already mentioned in the previous chapters:

1. Sampling (including suitable storage, if necessary)
  2. Sample treatment and preparation
  3. Expected water content and selection of suitable instrument
  4. Selection of optimum sample size
  5. Condition of the KF reagents, i.e. fresh reagents, pre-titration, low drift value, ...
  6. Sealed titration vessel and tight tubing,
  7. Condition of the indication electrode
  8. Coulometry: condition of the generating cell
  9. Parameter settings in the titration method
- etc.

To determine the closeness of agreement between the result of measurement and the true sample value, measurements can be performed either by titrating water standards or by titrating samples with known water content. The measurement accuracy depends on all the various factors described and explained in the previous sections. The crucial factors are optimum control as well as the water content and the amount of the sample.

### 8.3 Repeatability

The closeness of the agreement between the results of **successive measurements** of the same sample can be expressed quantitatively as the relative standard deviation,  $s_{rel}$ , given as %. With optimum sample amount and control, the following values can be obtained under test conditions for repeatability.

The graph shows the relative standard deviation for different water contents. In general, the repeatability of a sample series becomes worse with decreasing water content. Note that for water content below 10 ppm it is not recommended to use a volumetric technique.

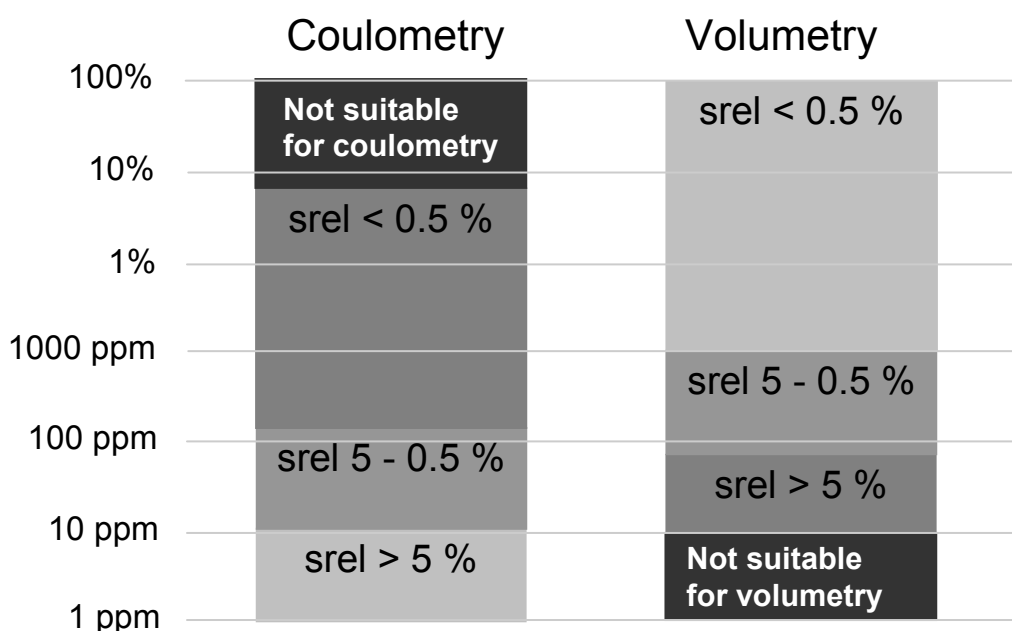

In the following graphs, the relative standard deviation  $s_{rel}$  (%) of several series with different water content are given as a function of the sample size:



**Relative standard deviation srel vs. sample size for different water contents:**

*KF Coulometry*

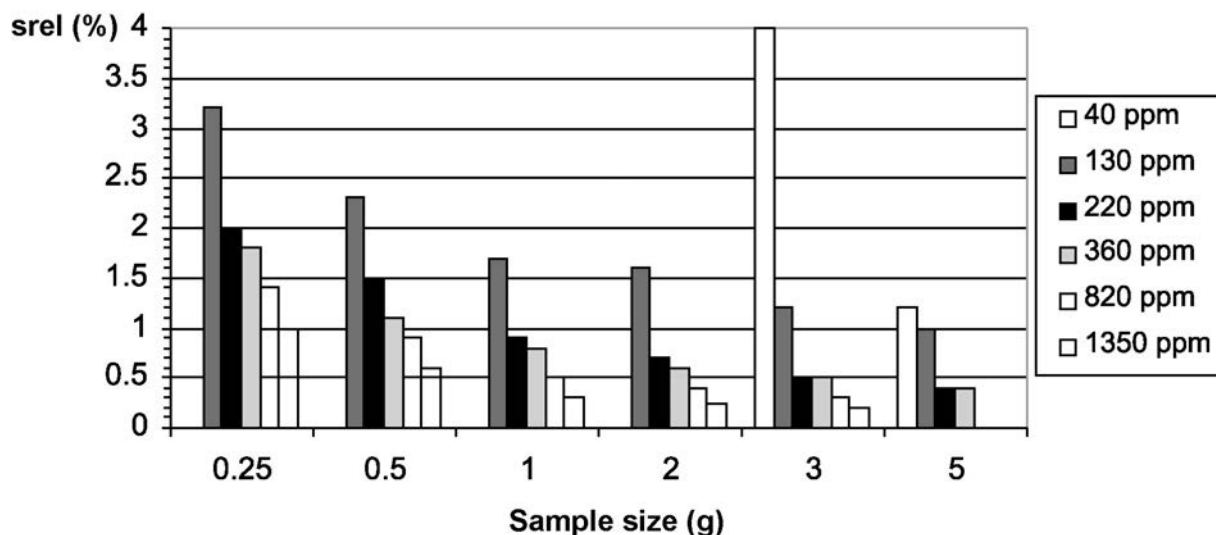

*KF Volumetric Titration:*

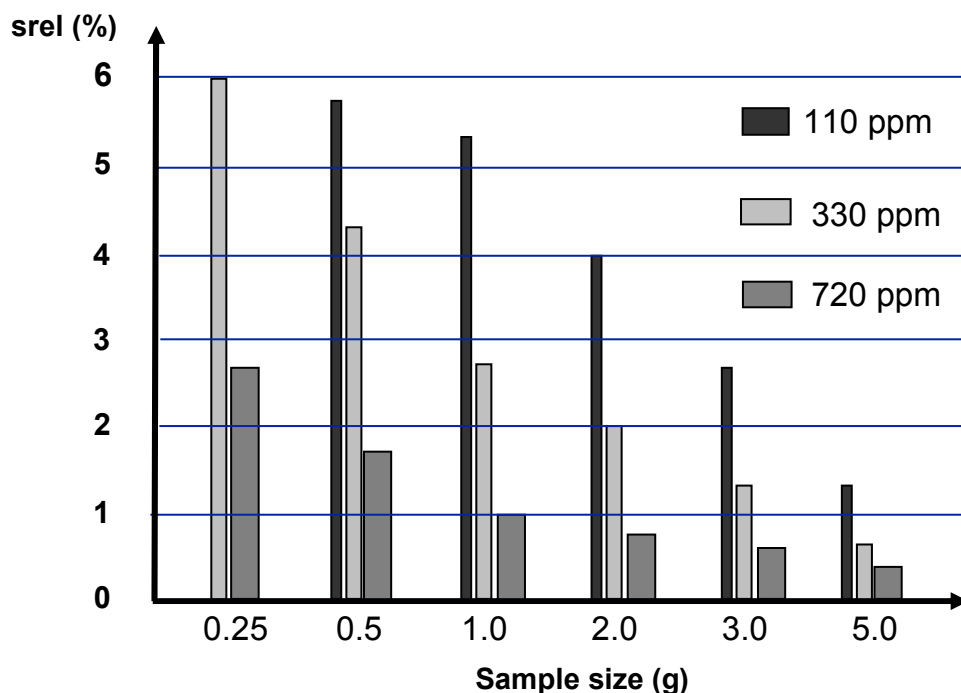

In both cases, with decreasing sample size the relative standard deviation srel becomes worse. Therefore, it is necessary to use the optimum sample size in order to achieve precise results. A good repeatability is achieved the sample size is increased particularly for low water content values.

## 9 Interferences

### 9.1 Effects of temperature

#### Temperature effects on the KF titrant

The Karl Fischer titrants consist of approximately 90% methanol or ethanol. Their volume increases considerably if the temperature increases, and their concentration decreases accordingly. S. Eberius [3] specifies a correction factor of 0.0012 per degree Celsius for methanolic Karl Fischer solutions. According to ISO 760, a temperature increase of 1 °C causes a drop of 0.1% in the concentration.

The titrant (in particular, the two-component KF solvent) may lose sulfur dioxide if the temperature rises. This causes bubbles to form in the titrant tubing, an effect which is worse the faster the rate at which the burette is filled.

These titrators allow you to define the filling rate of the burette separately for each titrant, e.g.:

| Temperature / °C   | < 15 | 15 – 30 | > 30 |
|--|------|---------|------|
| Filling rate for one-component KF volumetric titrant / % | 100  | 100     | 70   |
| Filling rate for two-component KF volumetric titrant / % | 80   | 60      | 40   |

#### Titration at low temperatures

You can perform Karl Fischer titrations at low temperature to eliminate undesired side reactions. The water content of peroxides, for example, can be determined at -40 °C. You must use the two-component reagent to do so, because the reaction rate of the one-component reagent is too slow at this temperature.

#### Titration at high temperatures

Increasing the titration temperature speeds up the dissolution of the sample or the extraction of the water from it, resulting in shorter titration times. Titrations at elevated temperature have proved particularly effective for foodstuffs, e.g. sugar, flour, potato flakes, hazelnuts, custard powder. The maximum temperature depends on the boiling point of the reagent (boiling point of methanol: 64 °C, boiling point of ethanol: 78 °C).

### 9.2 Side reactions

Side reactions that falsify the results can occur parallel to the Karl Fischer titration. There are mainly three side reactions that can affect the result:

1. Reaction with methanol, CH<sub>3</sub>OH
  - Aldehydes and ketones react with methanol leading to *additional water*
  - Esterification with carboxylic acids leading to *additional water*
2. Reaction with water, H<sub>2</sub>O
  - Ketones and aldehydes react with sulphur dioxide, a base and water (i.e. *water is consumed*)
3. Reaction with iodine, I<sub>2</sub>
  - The reaction of iodine with e.g. oxides, hydroxides, carbonates, amines, ascorbic acid, and mercaptans leads to a higher *consumption of iodine* giving higher water content.

### 9.2.1 Reaction with methanol

*Aldehydes and ketones:*

Methanol, CH<sub>3</sub>OH, reacts with *aldehydes* (R-CHO) and *ketones* (R-CO-R) to form *acetals* (CH<sub>3</sub>-CH(OR<sub>2</sub>)<sub>2</sub>), and (CH<sub>3</sub>)<sub>2</sub>C(OR<sub>2</sub>)<sub>2</sub> respectively, the latter also called *ketals*, as well as water:

Formation of acetals:

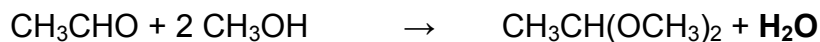

Formation of ketals:

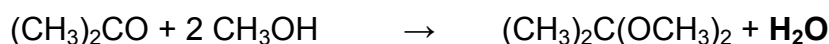

Solution:

- Use the special reagents for aldehydes and ketones with these substances (so-called K-reagents). They contain other alcohols than methanol.
- Experiments have shown that the side reaction still takes place despite these reagents. Each time acetone is determined, for example, the drift is higher than before the titration: the larger the sample, the greater the drift increase. It is therefore recommend to perform the determination with a small sample amount and to replace the solvent after two or three samples.

*Esterification:*

Methanol, CH<sub>3</sub>OH, reacts under presence of strong acids (i.e. sulfuric acid) with carboxylic acids (R-COOH) to an *ester* (R-O-CO-CH<sub>3</sub>) and additional water:

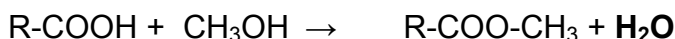

Solution:

- First neutralize the sample using a suitable base (imidazole) before KF titration.

### 9.2.2 Reaction with water

Another side reaction, *the bisulfite addition*, occurs with *aldehydes* and *ketones* in the presence of SO<sub>2</sub>. Water is consumed in the process.

Bisulfite addition:

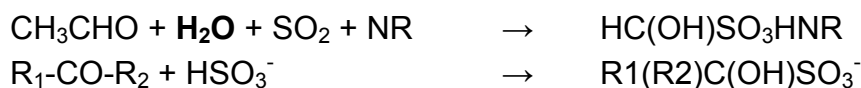

Note: SO<sub>2</sub> + H<sub>2</sub>O = HSO<sub>3</sub><sup>-</sup> + H<sup>+</sup>

Solution:

- Start the titration immediately after adding the sample.
- Perform a fast titration by predispensing 90% of titrant consumption

This causes the water to be titrated quickly, before any bisulfite addition can take place. The "Autostart" parameter allows for the automatic start of the titration as soon as the sample has been added and water is detected.

### 9.3 Reaction with iodine

The Karl Fischer reaction is a REDOX reaction with iodine as the oxidizing agent. Thus, iodine may also react with readily oxidizable samples. On the other hand, iodine can also be reduced by SO<sub>2</sub> in some samples such as e.g. oxides. Both reactions cause *additional iodine* being consumed, giving a false higher water content.

The following substances can react with iodine:

|  |  |   |
|--|--|---|
| Ascorbic acid                          | Arsenite, $\text{AsO}_2^-$               | Arsenate, $\text{AsO}_4^{3-}$                           |
| Boric acid, $\text{H}_3\text{BO}_3$    | Tetraborate, $\text{B}_4\text{O}_7^{2-}$ | Carbonate, $\text{CO}_3^{2-}$                           |
| Disulfite, $\text{S}_2\text{O}_5^{2-}$ | Iron(III) salts                          | Hydrazine, $\text{N}_2\text{H}_4$ , and its derivatives |
| Hydroxide, $\text{OH}^-$               | Hydrogencarbonate, $\text{HCO}_3^-$      | Copper(I) salts   |
| Mercaptans, R-SH                       | Nitrite, $\text{NO}_2^-$                 | Oxides, e.g. CaO, MgO, $\text{MnO}_2$                   |
| Peroxide, R-O-O-R                      | Selenite, $\text{SeO}_3^{2-}$            | Silanols, $\text{R}_3\text{-Si-OH}$                     |
| Sulfite, $\text{SO}_3^{2-}$            | Tellurite, $\text{TeO}_3^{2-}$           | Thiosulfate, $\text{S}_2\text{O}_3^{2-}$                |
| Tin(II) salts                          |  |   |

Solution:

The Karl Fischer titration for the majority of these substances can be performed with the aid of the *drying oven*, or also by performing an *external extraction*.

### 9.4 Example: reevaluation of side reactions

The water content obtained is too high if side reactions previously described have occurred. This can also be the case if a drying oven is used, and the sample slowly decomposes. Nevertheless, the correct result can be reevaluated by graphical extrapolation.

Example: Water determination in red polypropylene fibers.

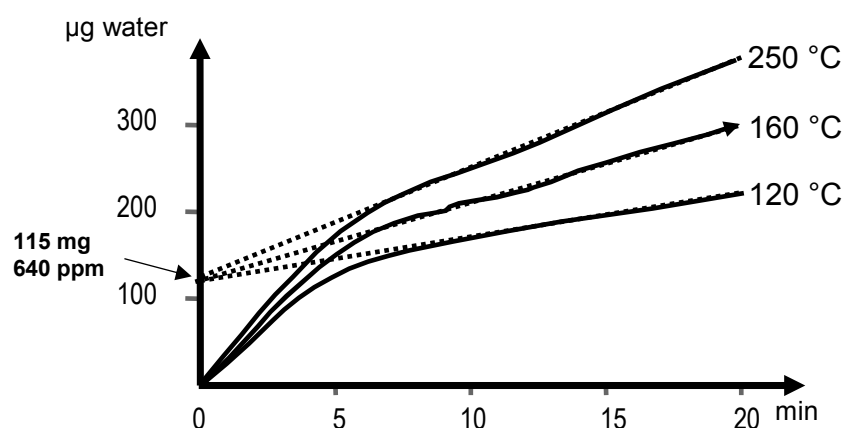

The determination was carried out for a period of 20 minutes (max. time) with the drying oven set to 120 °C, 160 °C and 250 °C. The following results were obtained:

| 120 °C   | 160 °C   | 280 °C   |
|----------|----------|----------|
| 1186 ppm | 1442 ppm | 1955 ppm |

The volume-time curve clearly indicates the occurrence of a side reaction, which becomes faster with increasing the temperature. The "water content" increases with temperature. By reevaluation using the LabX® titration PC software the actual water content can be obtained by extrapolating the titration curve to time  $t = 0$  min (green dotted lines). The content is 115 mg water; this corresponds to a water content of 640 ppm for a sample weight of 0.18 g. The extrapolated result was confirmed by an external extraction in methanol. In fact, the result obtained with this method was **610 ppm**.

## 10 Troubleshooting

### 10.1 Coulometry

| Problem   | Possible causes and action to take  |
|---|---|
| Anolyte is not bright yellow but dark yellow to brown       | <ul style="list-style-type: none"> <li>- Clean the platinum pins of the measurement electrode with paper tissue</li> <li>- Measurement electrode is not plugged in</li> <li>- Measurement electrode is faulty</li> </ul>  |
| Drift is too high after the pretitration of a fresh anolyte | <p><i>Titration stand not protected against moisture</i></p> <ul style="list-style-type: none"> <li>- Replace molecular sieves and silica gel in drying tube</li> <li>- Check whether titration stand is completely tight.</li> <li>- Grease the tapered joints</li> </ul>  |
| The drift remains too high during standby titration         | <p><i>Moisture from cathode compartment and diaphragm</i></p> <ul style="list-style-type: none"> <li>- Replace anolyte</li> <li>- Add a small amount of one-component KF titrant to the catholyte.</li> <li>- Level of anolyte should be higher than that of the catholyte</li> <li>- Clean titration cell and generator electrode and dry at 50 – 80 °C</li> <li>- Check whether titration stand is completely tight.</li> </ul> <p><i>Oven:</i></p> <ul style="list-style-type: none"> <li>- Replace silica gel and molecular sieve in the gas drying unit</li> </ul>   |
| Drift is too high after the titration of a sample           | <p><i>Side reaction with the anolyte</i></p> <ul style="list-style-type: none"> <li>- Use a different method</li> </ul> <p><i>Oven: water not completely vaporized</i></p> <ul style="list-style-type: none"> <li>- Higher oven temperature</li> <li>- Increase vaporization time, e.g. increase t(max)</li> </ul>  |
| Long titration time, titration never ends                   | <p><i>Wrong control parameters</i></p> <ul style="list-style-type: none"> <li>- Use rel. drift stop as termination parameter.</li> <li>- Increase value for rel. drift stop</li> <li>- Increase end point</li> </ul> <p><i>Oven: water vaporizes very slowly and irregularly</i></p> <ul style="list-style-type: none"> <li>- Use t(max) as termination parameter</li> <li>- Use higher oven temperature</li> <li>- Lengthen vaporization time (increase t max)</li> <li>- Use smaller sample</li> </ul>  |
| Very long pretitration                                      | <p><i>Wet anolyte</i></p> <ul style="list-style-type: none"> <li>- Replace anolyte</li> </ul>   |
| Poor repeatability  | <p><i>Amount of sample too small</i></p> <ul style="list-style-type: none"> <li>- Increase amount of sample to ensure that approx. 1 mg water per sample is present.</li> </ul> <p><i>Water distribution in the sample is not homogeneous</i></p> <ul style="list-style-type: none"> <li>- Homogenize sample, if possible increase amount of sample</li> </ul> <p><i>Wrong sample preparation and sample addition</i></p> <ul style="list-style-type: none"> <li>- The repeatability is strongly dependent on suitable sample preparation and sample addition, especially at low water content (&lt; 1000 ppm)</li> </ul> |

| Problem   | Possible causes and action to take  |
|---|---|
| Values too low  | <p><i>The titration was terminated too soon</i></p> <ul style="list-style-type: none"> <li>- Reduce the value for rel. drift stop</li> <li>- Extend t<sub>min</sub> (minimum titration time)</li> </ul> <p><i>Incomplete sample addition</i></p> <ul style="list-style-type: none"> <li>- Use back weighing.</li> <li>- Add sample into KF reagents, do not splash to the walls of the cell.</li> </ul> <p><i>Sample not dissolved (emulsion)</i></p> <ul style="list-style-type: none"> <li>- Replace analyte</li> <li>- Add chloroform or another solvent (maximum of 30%) to the analyte to dissolve the sample</li> </ul> <p><i>Oven:</i></p> <ul style="list-style-type: none"> <li>- Use higher oven temperature</li> <li>- Lengthen vaporization time (increase t<sub>max</sub>)</li> <li>- Use smaller sample size</li> </ul> |
| Values too high   | <p><i>The titration was too fast → overtitration</i></p> <ul style="list-style-type: none"> <li>- Replace or change the analyte</li> <li>- Clean titration cell and measurement electrode</li> </ul> <p><i>Poor sample preparation and addition</i></p> <p>Samples of low water content (&lt; 1000 ppm) are always hygroscopic. If the sample preparation and addition is not done carefully, contamination with atmospheric moisture occurs.</p> <p><i>For samples with very low water content &lt; 30 ppm</i></p> <ul style="list-style-type: none"> <li>- Use fix generator current 100 mA</li> <li>- Use start cautious</li> </ul> <p><i>Oven:</i></p> <ul style="list-style-type: none"> <li>- Sample not thermal stable: Use lower oven temperature</li> <li>- Sample is oxidized: use nitrogen as a purge gas</li> </ul>       |
| Checking coulometer<br>Out of limits,<br>bad repeatability  | <p><i>With water standard 1.0 or 0.1 mg/g</i></p> <ul style="list-style-type: none"> <li>- Too high value: see above “too high value”</li> <li>- Too low value: see above “too low value”</li> </ul> <p>if this does not help, the Coulometer must be adjusted</p>  |
| Checking drying oven<br>Out of limits,<br>bad repeatability | <p><i>With water Standard KF Oven 1 %; at 170 °C, 10 – 15 minutes</i></p> <ul style="list-style-type: none"> <li>- Check drift and blank value</li> <li>- use a bigger sample size up to 0.2 - 0.3 g</li> </ul>   |
| Platinum parts of the<br>generator are colored<br>black     | <p><i>Generator electrode is contaminated</i></p> <p>The black cover cannot be removed. It has no influence to the result.</p>  |
| Warning:<br>“Conductivity too low”                          | <p><i>Analyte has too low conductivity</i></p> <ul style="list-style-type: none"> <li>- Replace analyte</li> </ul> <p>If this doesn't help, check generator electrode.</p> <ul style="list-style-type: none"> <li>- Replace or repair generator electrode, if it is defective.</li> </ul>   |

## 10.2 Volumetric Karl Fischer Titration

| Problem   | Possible causes and action to take  |
|---|---|
| Titrated solution is dark                           | <p><i>Overtitration</i></p> <ul style="list-style-type: none"> <li>- Clean platinum pins of the electrode with a paper towel.</li> </ul>  |
| Drift too high after pretitration of fresh solvent  | <p><i>Titration stand not protected against moisture</i></p> <ul style="list-style-type: none"> <li>- Replace molecular sieves and silica gel in drying tube</li> <li>- Check whether titration stand is completely tight.</li> <li>- Grease the tapered joints</li> </ul> <p><i>Condition Titration stand</i></p> <ul style="list-style-type: none"> <li>- Shake titration vessel</li> </ul>   |
| The drift remains too high during standby titration | <p><i>Titration stand not protected against moisture</i></p> <ul style="list-style-type: none"> <li>- see above</li> </ul> <p><i>Oven:</i></p> <ul style="list-style-type: none"> <li>- Replace silica gel and molecular sieve in the gas drying unit</li> </ul>  |
| Drift too high after titration of a sample          | <p><i>The sample has not completely dissolved and continuously releases water</i></p> <ul style="list-style-type: none"> <li>- Use longer mixing time or different solvents which dissolves the sample or extracts the water quicker.</li> </ul> <p><i>Side reaction of the sample with the KF reagent</i></p> <ul style="list-style-type: none"> <li>- Use different method, e.g. external extraction, drying oven, etc.</li> </ul> <p><i>Oven: water is not completely vaporized</i></p> <ul style="list-style-type: none"> <li>- Increase oven temperature</li> <li>- Increase vaporization time, e.g. increase t(max)</li> </ul>                                    |
| Long titration time; titration never ends           | <p><i>Wrong termination parameters</i></p> <ul style="list-style-type: none"> <li>- Use "Rel. drift stop" as a termination parameter.</li> <li>- Increase value for relative drift stop.</li> <li>- Extend tmax (maximum titration time)</li> <li>- Increase endpoint potential</li> </ul> <p><i>Oven: water vaporizes very slowly and irregularly</i></p> <ul style="list-style-type: none"> <li>- Use t(max) as termination parameter</li> <li>- Use higher oven temperature</li> <li>- Extend vaporization time (increase t max)</li> <li>- Reduce sample size</li> </ul>  |
| Poor repeatability of the results                   | <p><i>Amount of sample too small</i></p> <ul style="list-style-type: none"> <li>- Increase amount of sample to ensure 10 mg water per sample.</li> </ul> <p><i>Water distribution in the sample not homogeneous</i></p> <ul style="list-style-type: none"> <li>- Homogenize sample, if possible increase amount of sample.</li> </ul> <p><i>Wrong control parameters</i></p> <ul style="list-style-type: none"> <li>- Check and optimize control parameters.</li> </ul> <p><i>Low water content (&lt;1000 ppm)!</i></p> <ul style="list-style-type: none"> <li>- The repeatability is strongly dependent on suitable sample preparation and sample addition.</li> </ul> |

| Problem   | Possible causes and action to take   |
|---|--|
| Values too low  | <p><i>The titration was terminated too soon</i></p> <ul style="list-style-type: none"> <li>- Reduce the value for rel. drift stop</li> <li>- Extend t<sub>min</sub> (minimum titration time)</li> </ul> <p><i>Incomplete sample addition</i></p> <ul style="list-style-type: none"> <li>- Use back weighing.</li> </ul> <p><i>Sample not dissolved</i></p> <ul style="list-style-type: none"> <li>- Replace solvent</li> <li>- Add chloroform or other solvent to methanol, which dissolves the sample.</li> </ul> <p><i>Oven:</i></p> <ul style="list-style-type: none"> <li>- Use higher oven temperature</li> <li>- Extend vaporization time (increase t<sub>max</sub>)</li> <li>- Reduce sample size</li> </ul>  |
| Single values too high  | <p><i>Control parameters too fast (= slight overtitration)</i></p> <ul style="list-style-type: none"> <li>- Reduce dV<sub>max</sub> and dV<sub>max</sub> factor.</li> </ul> <p><i>Poor sample preparation and addition</i></p> <ul style="list-style-type: none"> <li>- Samples of low water content (&lt;1000 ppm) are always hygroscopic. If the sample preparation and addition is done carefully, contamination with atmospheric moisture occurs.</li> </ul> <p><i>For samples with low water content &lt; 400 ppm</i></p> <ul style="list-style-type: none"> <li>- Use titrant with 2 or 1 mg/mL</li> </ul> <p><i>Oven:</i></p> <ul style="list-style-type: none"> <li>- Sample is not thermally stable: Use lower oven temperature</li> <li>- Sample is oxidized: use nitrogen as a purge gas</li> </ul> |
| The results in a series are continuously decreasing                               | <p><i>Dissolving capacity of the solvent is exhausted</i></p> <ul style="list-style-type: none"> <li>- Change solvent or use fresh solvent after every sample.</li> </ul>  |
| Very slow titration with two-component titrant                                    | <p><i>No more sulfur dioxide in the solvent</i></p> <ul style="list-style-type: none"> <li>- Change solvent.</li> </ul>  |
| Wrong or greatly fluctuating values in the concentration determination with water | <p><i>Water as standard requires practice</i></p> <p>The use of water for the concentration determination requires experience to obtain repeatable and accurate results. Determination of the concentration using di-sodium tartrate or Water Standard 10.0 is a simpler and a more dependable method.</p>   |
| Increasing value in the concentration determination with di-sodium tartrate       | <p><i>Di-sodium tartrate has only limited solubility</i></p> <p>In methanol max. 0.12 g in 40 mL.</p> <ul style="list-style-type: none"> <li>- Replace the solvent frequently. The concentration determination is correct only if the di-sodium tartrate has completely dissolved.</li> </ul>  |
| Checking drying oven<br>Out of limits,<br>bad repeatability                       | <p><i>With water Standard KF Oven 5.55 % at 220 °C, 15 – 20 minutes</i></p> <ul style="list-style-type: none"> <li>- Check drift and blank value</li> <li>- Increase sample size up to 0.4 g</li> </ul>  |



# 11 Karl Fischer Titration: The Method at a Glance

## 11.1 Solid samples

### 11.1.1 Organic Chemicals

| Substance                          | Examples  | Method                        | Substance                       | Examples   | Method                      |
|------------------------------------|---|-------------------------------|---------------------------------|--|-----------------------------|
| <b>Acetals</b>                     | $R_1\text{-CH}(\text{OR}_2)_2$  | <b>V2, C20</b>                | <b>Halogenated hydrocarbons</b> | R-Cl, R-Br, R-I  | <b>V2,V4,V5<br/>C20,C22</b> |
| <b>Aldehydes</b>                   | Chlorobenzaldehyde,<br>nitrobenzaldehyde                                  | <b>V11<br/>C0</b>             | <b>Isocyanates</b>              | R-NCO  | <b>V2,V4,V8<br/>C20</b>     |
| <b>Mono-/poly-alcohols</b>         | > C <sub>12</sub> Stearyl alcohol,<br>diphenylmethanol                    | <b>V2,V3,<br/>V4<br/>C20</b>  | <b>Ketones</b>                  | Benzophenone   | <b>V10, C24</b>             |
| <b>Amines</b>                      | <i>Weakly basic</i> $pK_a > 8$ :<br>Imidazole, indole,<br>carbazole       | <b>V2<br/>C20</b>             | <b>Hydrocarbons</b>             | > C <sub>12</sub><br>Biphenyl,<br>anthracene, pyrene,<br>naphthalene                                   | <b>V4,V5<br/>C20,C22</b>    |
|                                    | <i>Strongly basic</i> :<br>aminopyridine                                  | <b>V16<br/>C0</b>             |                                 | > C <sub>20</sub><br>Tar, bitumen  | <b>V3,V7</b>                |
|                                    | <i>Reaction with methanol</i> :<br>naphthylamine,<br>anisidine, toluidine | <b>V10<br/>C0</b>             | <b>Nitro-compounds</b>          | di-Nitrobenzene,<br>nitrotoluene,<br>nitrochlorobenzene  | <b>V2,V3<br/>C20</b>        |
|                                    | <i>Oxidizable with iodine</i> :<br>aminophenol                            | <b>V0, C0</b>                 | <b>Peroxides</b>                | Dialkylperoxide<br>R-OO-R<br>Alkylperoxide<br>R-OOH  | <b>V2,V3,V4<br/>C20</b>     |
| <b>Carbamates</b>                  | RO-CONH <sub>2</sub>  | <b>V2, V3,<br/>V4</b>         |                                 | Diacyl peroxide  | <b>V0, C0</b>               |
| <b>Carboxylic acid amides</b>      | R-CONR', e.g.:<br>benzamide,<br>stearamide                                | <b>V2, V3,<br/>V4<br/>C20</b> | <b>Phenols</b>                  | <i>Low pK<sub>a</sub> value</i> :<br>phenol, cresol,<br>salicylic acid                                 | <b>V2<br/>C20</b>           |
| <b>Mono-/poly-carboxylic acids</b> | <i>Weakly acidic</i> :<br>benzoic acid                                    | <b>V2, V3,<br/>V4<br/>C20</b> |                                 | <i>High pK<sub>a</sub> value</i> :<br>2-chlorophenol,<br>o-cresol                                      | <b>V15</b>                  |
|                                    | <i>Strongly acidic</i> :<br>malonic acid, oxalic acid                     | <b>V15<br/>C20</b>            |                                 | <i>Side reaction</i> :<br>naphthol,<br>aminophenol   | <b>V0, C0</b>               |
|                                    | <i>Oxidizable with iodine</i> :<br>ascorbic acid                          | <b>V0, C0</b>                 | <b>Sulfur compounds</b>         | Aromatic/aliphatic<br>sulfonic acids<br>sulfides R-S-R'<br>disulfides R-SS-R'<br>thiocyanates<br>R-SCN | <b>V2,V4,V5<br/>C20</b>     |
| <b>Ethers</b>                      | Linear and cyclic   | <b>V2,V4,<br/>V5<br/>C20</b>  |                                 | Mercaptans   | <b>V0, C0</b>               |
| <b>Esters</b>                      | Carboxylic acid ester<br>R-COOR'<br>Carbonic anhydride<br>ROCOOR'         | <b>V2,V3,<br/>V4<br/>C20</b>  |                                 |  |                             |

## 11.1.2 Inorganic chemicals

| Substance                      | Examples   | Method                                       |
|--------------------------------|--|--|
| <b>Arsenic compounds</b>       | Na <sub>2</sub> HAsO <sub>3</sub> ,<br>NaAsO <sub>2</sub>                            | <b>V30</b><br><b>C30</b>                     |
| <b>Bicarbonates carbonates</b> | KHCO <sub>3</sub> , NaHCO <sub>3</sub> ,<br>Na <sub>2</sub> CO <sub>3</sub>          | <b>V34</b><br><b>C32</b>                     |
| <b>Boron compounds</b>         | B <sub>2</sub> O <sub>3</sub> , HBO <sub>3</sub> ,<br>H <sub>3</sub> BO <sub>3</sub> | <b>V31</b><br><b>C32</b>                     |
| <b>Hydroxides, oxides</b>      | NaOH, KOH<br>MgO, CaO  | <b>V21, V32</b><br><b>C21,</b><br><b>C34</b> |
| <b>Halogenides</b>             | NaCl, KJ, CaCl <sub>2</sub> ,<br>MgCl <sub>2</sub>                                   | <b>V2, V32</b><br><b>C20,</b><br><b>C34</b>  |
|                                | Cu(I) salts: CuCl <sub>2</sub>   | <b>V31</b><br><b>C33</b>                     |
| <b>Nitrates</b>                | NaNO <sub>3</sub> , NH <sub>4</sub> NO <sub>3</sub>                                  | <b>V2, V31</b><br><b>C20,</b><br><b>C32</b>  |
| <b>Nitrites</b>                | NaNO <sub>2</sub>  | <b>V31</b><br><b>C32</b>                     |

| Substance                | Examples   | Method                            |
|--------------------------|--|-----------------------------------|
| <b>Phosphates</b>        | NaH <sub>2</sub> PO <sub>4</sub> ,<br>Na <sub>2</sub> HPO <sub>4</sub>   | <b>V2, V31</b><br><b>C20, C32</b> |
|                          | tert. Phosphate,<br>e.g.: Na <sub>3</sub> PO <sub>4</sub>  | <b>V15, V31</b><br><b>C32</b>     |
| <b>Silicon compounds</b> | Silicon oxide,<br>Silicon dioxide  | <b>V2, V32</b><br><b>C20, C34</b> |
|                          | Silanols<br>R <sub>3</sub> Si(OH)  | <b>V10</b>                        |
| <b>Sulfates</b>          | Na <sub>2</sub> SO <sub>4</sub> , ZnSO <sub>4</sub>  | <b>V2, V32</b><br><b>C21, C34</b> |
| <b>Thiosulfates</b>      | Na <sub>2</sub> S <sub>2</sub> O <sub>3</sub> , NaSO <sub>3</sub> ,<br>Na <sub>2</sub> S <sub>2</sub> O <sub>5</sub> | <b>V2, V31</b><br><b>C20, C32</b> |
| <b>Tin(II)salts</b>      | SnCl <sub>2</sub>  | <b>V31</b><br><b>C32</b>          |

## 11.1.3 Technical products – organic

| Substance                | Examples   | Method                             |
|--------------------------|--|------------------------------------|
| <b>Agro-chemicals</b>    | Insecticides,<br>fungicides,<br>herbicides   | <b>V2</b>                          |
| <b>Dyes</b>              | <i>Soluble:</i> wool dyes,<br>indicator dyes, etc.   | <b>V2</b>                          |
|                          | <i>Insoluble:</i><br>pigments,<br>dispersion dyes  | <b>V2, V8</b>                      |
| <b>Cosmetics</b>         | Creams, lotion   | <b>V4, V5</b>                      |
|                          | Lipstick   | <b>V5</b>                          |
|                          | Soaps  | <b>V2</b>                          |
|                          | Toothpaste   | <b>V20</b>                         |
| <b>Adhesives</b>         | All-purpose glue,<br>glue stick  | <b>V2</b>                          |
|                          | Rubber cement  | <b>V5</b>                          |
| <b>Plastics Polymers</b> | Polyethylene, PVC,<br>polypropylene,<br>poly-amides,<br>polystyrene,<br>polyurethane, etc. | <b>V30, V31</b><br><b>C31, C32</b> |

| Substance                    | Examples                                      | Method                  |
|------------------------------|---|-------------------------|
| <b>Petro-chemicals</b>       | Waxes, paraffins:<br>shoepolish,<br>ski wax   | <b>V12</b><br><b>C0</b> |
|                              | Tar, bitumen                                  | <b>V7</b>               |
|                              | lubricating grease,<br>multipurpose<br>grease | <b>V5, V30</b>          |
| <b>Pharma-<br/>ceuticals</b> | Antibiotics,<br>disinfectants                 | <b>V2</b>               |
|                              | Salves, creams                                | <b>V4, V5</b>           |
|                              | Suppositories                                 | <b>V12</b>              |
|                              | Tablets                                       | <b>V2</b>               |
|                              | Lyophilized<br>preparations                   | <b>V40, C40</b>         |
| <b>Textile auxiliaries</b>   | Surfactants powder<br>optical brightener      | <b>V2</b>               |

## 11.1.4 Technical products - inorganic

| Substance                 | Examples                | Method           |
|---------------------------|-------------------------|------------------|
| <b>Building materials</b> | Mortar, plaster, cement | <b>V32 (C34)</b> |
| <b>Fertilizers</b>        | Adherent moisture       | <b>V6</b>        |
|                           | Total water             | <b>V30</b>       |

| Substance         | Examples   | Method          |
|-------------------|--|-----------------|
| <b>Minerals</b>   | Zeolites   | <b>V32</b>      |
| <b>Detergents</b> | Laundry detergent with brightener (hydroxides, perborates) | <b>V30, V21</b> |
|                   | without brightener   | <b>V2</b>       |

## 11.1.5 Technical natural products

| Substance                 | Examples         | Method          |
|---------------------------|------------------|-----------------|
| <b>Cellulose products</b> | Paper, wood      | <b>V30, C30</b> |
|                           | Cellulose powder | <b>V2</b>       |
| <b>Fibrous materials</b>  | Wool, silk       | <b>V20</b>      |

## 11.1.6 Food

| Substance               | Examples                                | Method           |
|-------------------------|---|------------------|
| <b>Protein products</b> | Cheese, meat spread, broth              | <b>V23</b>       |
|                         | Yogurt, ice cream                       | <b>V2</b>        |
|                         | Dried albumen                           | <b>V13</b>       |
|                         | Powdered milk                           | <b>V2, V23</b>   |
| <b>Fats</b>             | Butter, margarine, mayonnaise           | <b>V4, V5</b>    |
|                         | Shortening, hardened fat                | <b>V5</b>        |
| <b>Spices</b>           | Pepper, curry, mixed spice              | <b>V23</b>       |
|                         | Mustard                                 | <b>V24, (V5)</b> |
|                         | Adherent moisture: plain salt, sea salt | <b>V6 C23</b>    |
|                         | Total water: plain salt, sea salt       | <b>V32 C34</b>   |

| Substance                       | Examples  | Method            |
|---------------------------------|---|-------------------|
| <b>Grains and starchy foods</b> | Biscuits, Zwieback, noodles, wheat, rye, corn, potato chips   | <b>V13, (V30)</b> |
|                                 | Potato flakes   | <b>V22, V23</b>   |
|                                 | Dough, noodles, Zwieback  | <b>V30, (V25)</b> |
| <b>Vegetable products</b>       | Cacao, coffee beans, tea, instant coffee, tobacco, dried vegetables and fruits                      | <b>V22, V23</b>   |
|                                 | Hazelnuts, almonds instant coffee   | <b>V13</b>        |
| <b>Sugar and sugar products</b> | Sugar: total water cont., jellied fruits, gummi bears, candy, caramel, pudding powder, almond paste | <b>V13</b>        |
|                                 | Instant ice tea, jam  | <b>V8</b>         |
|                                 | Honey, jelly  | <b>V2</b>         |
|                                 | Sugar: adherent moisture  | <b>V6</b>         |
|                                 | Chocolate   | <b>V5</b>         |

## 11.2 Liquid samples

### 11.2.1 Organic and inorganic chemicals

| Substance                       | Examples   | Method                   | Substance                        | Examples   | Method                  |
|---------------------------------|--|--------------------------|----------------------------------|--|-------------------------|
| <b>Acetals</b>                  | Acetal, ethylal, methylal  | <b>V1</b><br><b>C1</b>   | <b>Hydrocarbons</b>              | $C_1$ to $C_7$<br>hexane,<br>pentane,<br>isobutane,<br>cyclohexene,<br>cyclohexane,<br>benzene,<br>toluene, xylene | <b>V1</b><br><b>C1</b>  |
| <b>Aldehyde</b>                 | Acetaldehyde,<br>benzaldehyde  | <b>V11</b><br><b>C0</b>  | <b>saturated and unsaturated</b> | $C_7$ to $C_{14}$<br>gasoline,<br>petroleum,<br>dodecane   | <b>V4</b><br><b>C1</b>  |
| <b>Alcohols</b>                 | Propanol, hexanol,<br>benzyl alcohol   | <b>V1</b><br><b>C1</b>   |                                  | $> C_{14}$<br>heavy oil, crude<br>oil, paraffin  | <b>V5</b><br><b>C30</b> |
| <b>Amines</b>                   | <b>Weakly basic:</b><br>N-methyl aniline<br>heterocyclic amines<br>pyridine, chinoline | <b>V1</b><br><b>C1</b>   | <b>Mineral acids</b>             | $H_2SO_4$ ,<br>$HNO_3$ ,<br>HCl  | <b>V15</b><br><b>C0</b> |
|                                 | <b>Strongly basic:</b><br>aliphatic amines<br>N-butylamine,<br>hexylamine              | <b>V16</b><br><b>C0</b>  | <b>Nitro-compounds</b>           | Nitrobenzene,<br>nitrotoluene,<br>nitrochloro-<br>benzene  | <b>V1</b><br><b>C1</b>  |
|                                 | <b>Reaction with methanol:</b><br>aniline, toluidine,<br>diamine                       | <b>V10</b><br><b>C0</b>  | <b>Nitriles</b>                  | Acetonitrile   | <b>V1</b><br><b>C1</b>  |
|                                 | <b>Easily oxidized with iodine:</b><br>hydrazine,<br>hydroxylamine                     | <b>V0</b><br><b>C0</b>   | <b>Peroxides</b>                 | $H_2O_2$   | <b>V15</b>              |
| <b>Carboxylic acids</b>         | $C_1$ to $C_2$<br>formic acid, acetic<br>acid  | <b>V15</b><br><b>C0</b>  | <b>Acid amides</b>               | Dimethyl-<br>formamide   | <b>V1, C1</b>           |
|                                 | $> C_2$<br>propionic acid,<br>acrylic acid   | <b>V1</b><br><b>C1</b>   | <b>Sulfur-compounds</b>          | Sulfides,<br>disulfides<br>sulfonic acids  | <b>V1</b><br><b>C1</b>  |
| <b>Ethers</b>                   | Dimethylether,<br>dioxane, anisole   | <b>V1</b><br><b>C1</b>   |                                  | Mercaptans   | <b>V0, C0</b>           |
| <b>Esters</b>                   | Methyl benzoate,<br>ethyl acetate  | <b>V1</b><br><b>C1</b>   |                                  |  |                         |
| <b>Halogenated hydrocarbons</b> | Methyl chloride,<br>t-butyl chloride,<br>chlorobenzene,<br>chlorotoluene               | <b>V1</b><br><b>C1</b>   |                                  |  |                         |
| <b>Ketones</b>                  | Acetone,<br>acetophenone,<br>methyl ethyl ketone                                       | <b>V10</b><br><b>C10</b> |                                  |  |                         |

### 11.2.2 Foods and technical products

| Substance                    | Examples  | Method                   |
|------------------------------|---|--------------------------|
| <b>Aqueous solutions</b>     | <b>Foods:</b><br>spiced sauce: soy sauce<br>beverages: beer, wine, liquor | <b>V1</b>                |
|                              | <b>Pharmaceuticals:</b><br>extrakts, tinctures                            | <b>V1</b>                |
|                              | <b>Cosmetics:</b><br>perfume, shampoo                                     | <b>V1</b>                |
| <b>Aqueous emulsions</b>     | Tensides and detergents   | <b>V1</b>                |
|                              | <b>Milk products:</b><br>milk, cream, condensed milk                      | <b>V4</b>                |
|                              | Tensides and detergents   | <b>V1</b>                |
|                              | Agrochemicals (sprays):<br>herbicides, fungicides                         | <b>V1</b>                |
| <b>Emulsions in solvents</b> | Acrylic enamels   | <b>V29</b>               |
|                              | Agrochemicals (sprays):<br>insecticides                                   | <b>V4</b><br><b>C1</b>   |
|                              | Synthetic enamels   | <b>V7</b>                |
| <b>Vegetable oils</b>        | <b>Foods:</b><br>salad oil, sunflower oil                                 | <b>V4</b><br><b>C1</b>   |
|                              | Pharmaceuticals and cosmetics:<br>ethereal oils, massage oil              | <b>V4</b><br><b>C1</b>   |
| <b>Technical oils</b>        | Hydraulic oil, brake fluid, transformer oil, silicon oil                  | <b>V5</b><br><b>C1</b>   |
|                              | Motor oils  | <b>V30</b><br><b>C30</b> |

For more details on the sample preparation, sample input and titration methods, refer to chapter 11.3.

## 11.3 Titration Methods

### 11.3.1 Volumetric methods

The methods have been developed using 2-component reagents. These can be also performed using the one-component reagent. In this case methanol is used as a solvent.

|            |  |
|------------|--|
| <b>V1</b>  | <b>Direct titration</b><br>Titrant: two component reagent 5 or 2 mg H <sub>2</sub> O/mL<br>Solvent: 40 mL KF solvent<br>Stir time: 10 s  |
| <b>V2</b>  | <b>Direct titration</b><br>Titrant: two component reagent 5 or 2 mg H <sub>2</sub> O/mL<br>Solvent: 40 mL KF solvent<br>Stir time: 60 - 120 s  |
| <b>V3</b>  | <b>Direct titration with added 2-propanol</b><br>Titrant: two component reagent 5 or 2 mg H <sub>2</sub> O/mL<br>Solvent: 40 mL KF solvent / propanol 1:1<br>Stir time: 60 - 120 s                             |
| <b>V4</b>  | <b>Direct titration with added 1-decanol</b><br>Titrant: two component reagent 5 or 2 mg H <sub>2</sub> O/mL<br>Solvent: 40 mL KF solvent / 1-decanol 1:1<br>Stir time: 60 - 120 s                             |
| <b>V5</b>  | <b>Direct titration with added chloroform</b><br>Titrant: two component reagent 5 or 2 mg H <sub>2</sub> O/mL<br>Solvent: KF solvent / chloroform 1:1 to 1:2<br>Stir time: 60 - 120 s                          |
| <b>V6</b>  | <b>Direct titration with added chloroform</b><br>Titrant: two component reagent 5 or 2 mg H <sub>2</sub> O/mL<br>Solvent: 40 mL KF solvent / chloroform 1:5<br>Stir time: 60 - 120 s<br>Delay time: 7 seconds. |
| <b>V7</b>  | <b>Direct titration with added toluene</b><br>Titrant: two component reagent 5 or 2 mg H <sub>2</sub> O/mL<br>Solvent: 40 mL KF solvent / toluene 1:1<br>Stir time: 60 - 120 s                                 |
| <b>V8</b>  | <b>Direct titration with added formamide</b><br>Titrant: two component reagent 5 mg H <sub>2</sub> O/mL<br>Solvent: 40 mL KF solvent / formamide 1:1<br>Stir time: 5 - 10 minutes                              |
| <b>V10</b> | <b>Direct titration methanol free</b><br>Titrant: two comp. reagent 5 mg H <sub>2</sub> O/mL for ketone und aldehyde<br>Solvent: 40 mL KF solvent for ketone und aldehyde<br>Stir time: 30 – 60 s              |
| <b>V11</b> | <b>Direct titration methanol free</b><br>Titrant: two comp. reagent 5 mg H <sub>2</sub> O/mL for ketone und aldehyde<br>Solvent: 40 mL KF solvent for ketone und aldehyde<br>Start immediately (autostart)     |
| <b>V12</b> | <b>Direct titration with heat (at 50°C)</b><br>Titrant: two component reagent 5 mg H <sub>2</sub> O/mL<br>Solvent: 40 mL KF solvent<br>Stir time: 5 - 10 minutes   |

|            |  |
|------------|--|
| <b>V13</b> | <b>Direct titration with added formamide and heat, 50°C</b><br><b>Titration:</b> two component reagent 5 mg H <sub>2</sub> O/mL<br><b>Solvent:</b> 40 mL KF solvent / formamide 1:1<br><b>Stir time:</b> 10 - 15 minutes   |
| <b>V15</b> | <b>Direct titration with neutralization</b><br><b>Titration:</b> two component reagent 5 mg H <sub>2</sub> O/mL<br><b>Solvent:</b> 30 mL KF solvent and 20 mL buffer or 7g imidazole<br><b>Stir time:</b> 60 - 120 s   |
| <b>V16</b> | <b>Direct titration with neutralization</b><br><b>Titration:</b> two component reagent 5 mg H <sub>2</sub> O/mL<br><b>Solvent:</b> 30 mL KF solvent and 5 g benzoic acid<br><b>Stir time:</b> 1-2 minutes  |
| <b>V20</b> | <b>External extraction with methanol at room temperature</b><br><b>Titration:</b> two component reagent 5 mg H <sub>2</sub> O/mL<br><b>Solvent:</b> 30 mL KF solvent   |
| <b>V21</b> | <b>External extraction with methanol at room temperature in sonicator</b><br>Remove aliquots of extraction solution over membrane filter with syringe.<br><b>Titration:</b> two component reagent 5 mg H <sub>2</sub> O/mL<br><b>Solvent:</b> 30 mL KF solvent                           |
| <b>V22</b> | <b>External extraction with methanol at 50 °C</b><br><b>Titration:</b> two component reagent 5 mg H <sub>2</sub> O/mL<br><b>Solvent:</b> 30 mL KF solvent  |
| <b>V23</b> | <b>External extraction with formamide</b><br><b>Titration:</b> two component reagent 5 mg H <sub>2</sub> O/mL<br><b>Solvent:</b> 30 mL KF solvent  |
| <b>V24</b> | <b>External extraction with 1-decanol/formamide 1:1</b><br><b>Titration:</b> two component reagent 5 mg H <sub>2</sub> O/mL<br><b>Solvent:</b> 30 mL KF solvent  |
| <b>V25</b> | <b>External extraction with 1-decanol/formamide/methanol 8:2:1</b><br><b>Titration:</b> two component reagent 5 mg H <sub>2</sub> O/mL<br><b>Solvent:</b> 30 mL KF solvent   |
| <b>V29</b> | <b>External extraction with formamide</b><br><b>Titration:</b> two component reagent 5 mg H <sub>2</sub> O/mL<br><b>Solvent:</b> 40 mL KF solvent / formamide 1:1  |
| <b>V30</b> | <b>With drying oven at 110 - 150°C</b><br><b>Titration:</b> two component reagent 5 or 2 mg H <sub>2</sub> O/mL<br><b>Solvent:</b> 50 mL KF solvent<br><b>Stir time:</b> 10 - 20 min   |
| <b>V31</b> | <b>With drying oven at 160 - 220°C</b><br><b>Titration:</b> two component reagent 5 or 2mg H <sub>2</sub> O/mL<br><b>Solvent:</b> 50 mL KF solvent<br><b>Stir time:</b> 10 - 20 min  |
| <b>V32</b> | <b>With drying oven at 300°C</b><br><b>Titration:</b> two component reagent 5 or 2 mg H <sub>2</sub> O/mL<br><b>Solvent:</b> 50 mL KF solvent<br><b>Stir time:</b> 10 - 20 min   |
| <b>V40</b> | <b>Special method for lyophilized preparations</b><br>Dissolve sample in septum flask with 10-20 mL titrated solvent and inject entire solution into titration cell and titrate.<br><b>Titration:</b> two component reagent 2 mg H <sub>2</sub> O/mL<br><b>Solvent:</b> 50 mL KF solvent |
| <b>V0</b>  | <b>Side reaction: KF titration not possible</b>  |

## 11.3.2 Coulometric methods

|            |  |
|------------|--|
| <b>C1</b>  | <b>Direct titration</b><br>Anolyte: 100 mL anode reagent<br>Catholyte: 5 mL cathode reagent  |
| <b>C5</b>  | <b>Direct titration with added chloroform</b><br>Anolyte: 70 mL anode reagent and 30 mL chloroform<br>Catholyte: 5 mL cathode reagent  |
| <b>C10</b> | <b>Direct titration methanol free</b><br>Anolyte: 100 mL anode reagent for ketones<br>Catholyte: 5 mL cathode reagent for ketones  |
| <b>C20</b> | <b>External extraction with methanol or external dissolution in methanol</b><br>Anolyte: 100 mL anode reagent<br>Catholyte: 5 mL cathode reagent   |
| <b>C21</b> | <b>External extraction with Methanol in sonicator</b><br>Remove aliquots of extraction solution over membrane filter with syringe.<br>Anolyte: 100 mL anode reagent<br>Catholyte: 5 mL cathode reagent   |
| <b>C22</b> | <b>External extraction with 1-decanol or external dissolution in 1-decanol</b><br>Anolyte: 100 mL anode reagent<br>Catholyte: 5 mL cathode reagent   |
| <b>C23</b> | <b>External extraction with chloroform or external dissolution in chloroform</b><br>Anolyte: 100 mL anode reagent<br>Catholyte: 5 mL cathode reagent   |
| <b>C24</b> | <b>External extraction or external dissolution in chloroform (methanol free)</b><br>Anolyte: 100 mL anode reagent for ketones<br>Catholyte: 5 mL cathode reagent for ketones   |
| <b>C30</b> | <b>With drying oven at 110-130°C</b><br>Anolyte: 100 mL anode reagent<br>Catholyte: 5 mL cathode reagent<br>Titration time: 10-20 minutes  |
| <b>C31</b> | <b>With drying oven at 140-150°C</b><br>Anolyte: 100 mL anode reagent<br>Catholyte: 5 mL cathode reagent<br>Titration time: 10-20 minutes  |
| <b>C32</b> | <b>With drying oven at 160-190°C</b><br>Anolyte: 100 mL anode reagent<br>Catholyte: 5 mL cathode reagent<br>Titration time: 10-20 minutes  |
| <b>C33</b> | <b>With drying oven at 200-250°C</b><br>Anolyte: 100 mL anode reagent<br>Catholyte: 5 mL cathode reagent<br>Titration time: 10-20 minutes  |
| <b>C34</b> | <b>With drying oven at 300°C</b><br>Anolyte: 100 mL anode reagent<br>Catholyte: 5 mL cathode reagent<br>Titration time: 10-20 minutes  |
| <b>C40</b> | <b>Special method for lyophilized preparations</b><br>Dissolve sample in septum flask with 10-20 mL titrated anolyte and inject entire solution into titration cell and titrate.<br>Anolyte: 100 mL anode reagent<br>Catholyte: 5 mL cathode reagent |
| <b>C0</b>  | <b>Coulometric determination not possible</b>  |



## 11.4 Sample preparation and input

### 11.4.1 Solids: Characteristics

| Property                        | Examples  | Method                  | Property                  | Examples  | Method             |
|---------------------------------|---|-------------------------|---------------------------|---|--------------------|
| <b>Very hard</b>                | Minerals, rocks<br>e.g.: CaCO <sub>3</sub> , SiO <sub>2</sub> | <b>S1</b>               | <b>Soft, greasy</b>       | Butter, margarine                                   | <b>S7, S10</b>     |
| <b>Hard, brittle</b>            | Salts, crystalline products                                   | <b>S1, S2</b>           | <b>Soft, brittle</b>      | Phenols, naphthalene, potato flakes                 | <b>S2, S3</b>      |
| <b>Hard natural products</b>    | Wheat, noodles, pepper, almonds, coffee, Zwieback             | <b>S1, S3, S10, S11</b> | <b>Soft, resinous</b>     | Tar, bitumen  | <b>S2, S5, S10</b> |
| <b>Fibrous natural products</b> | Dried vegetables and fruits, tobacco, tea, meat               | <b>S4, S10, S11</b>     | <b>Waxes</b>              | Paraffins, shoepolish                               | <b>S8</b>          |
| <b>Tenacious products</b>       | Jellied fruits, gummi bears, paper, wool, silk                | <b>S4, S10, S11</b>     | <b>Creams, pastes</b>     | Salves, creams gel, honey, jelly, ice cream, yogurt | <b>S9</b>          |
| <b>Soft products</b>            | Cheese, almond paste, broth                                   | <b>S10, S11</b>         | <b>Pulverized soluble</b> | Salts, active ingredients Na-tartrate               | <b>S12</b>         |
| <b>Hard, greasy</b>             | Hardened fat, chocolate                                       | <b>S6, S8, S10</b>      |                           |   |                    |

### 11.4.2 Solids: Sample input

|            |  |  |
|------------|--|--|
| <b>S1</b>  | finely ground sample with weighing boat                              | Grind in sealed, cooled analysis mill.   |
| <b>S2</b>  | finely ground sample with weighing boat                              | Pulverize with mortar.   |
| <b>S3</b>  | finely ground sample with weighing boat                              | Pulverize with mixer.  |
| <b>S4</b>  | with spatula   | Press through small holes e.g. meat grinder.   |
| <b>S5</b>  | with spatula or weighing boat  | Cut in small pieces with scissors or knife.  |
| <b>S6</b>  | with spatula or weighing boat  | Use grate to reduce size.  |
| <b>S7</b>  | with spatula<br>Do not use syringe, the moisture will be pressed out | Homogenize sample well. After sample removal keep sample sealed.   |
| <b>S8</b>  | with pre-heated syringe (with needle Ø 0.8 mm )                      | Melt sample.<br>(Pre-heat syringe with hair dryer or in drying oven.)  |
| <b>S9</b>  | Fill in backend of syringe   | Homogenize sample well. After sample removal keep sample sealed. Use syringe with needle Ø 1.5 mm or without needle; for very thick pastes drill hole in bottom of syringe.  |
| <b>S10</b> | syringe with needle Ø 0.8 mm   | In external extraction solvent (methanol, 1-decanol, formamide). Dissolve sample or extract water. Stir, shake or sonicate. At room temp. or up to approx. 60° C. Let solids settle and remove aliquot of remaining solution with syringe. Inject into titration cell. |
| <b>S11</b> | syringe without needle (Fill very thick samples in back of syringe)  | Break and disperse with high-speed mixer (up to 24000 cpm) in external extraction solvent (methanol, 1-decanol, formamide).  |
| <b>S12</b> | weighing boat  | No further preparation necessary. (Select stir time so that sample dissolves completely.)  |

### 11.4.3 Liquids: Characteristics

| Property                                     | Examples   | Method |
|--|--|--------|
| Liquid                                       | Propanol, acetone, gasoline, acetic acid             | L1     |
| Turbid                                       | Silicon oil, crude oil, glycerine                    | L2     |
| Low boiling point      5 - 15°C              | Acetaldehyde   | L3     |
| Hygroscopic                                  | Methanol, H <sub>2</sub> SO <sub>4</sub> , glycerine | L4     |
| Low moisture content    (< 1000 ppm)         | Hexane, toluene, petroleum, acetone, salad oil       | L4     |
| Non-hygroscopic,<br>average moisture content | Perfume, after-shave                                 | L1     |
| High moisture content    (> 50%)             | Beverages, detergents, milk, aqueous emulsions       | L5     |
| Inhomogeneous                                | Acrylic enamels, synthetic enamels, cream            | L6     |

### 11.4.4 Liquids: Sample input

|    |  |  |
|----|--|--|
| L1 | Injection with syringe<br>(with needle Ø 0.8 mm)                             | <b>Fluid liquid sample</b><br>Inject sample into titration cell through septum or needle hole of three-hole adapter with 1 mL or 10 mL syringe.  |
| L2 | Injection with syringe<br>(without or with needle Ø 1.5 mm)                  | <b>Turbid liquid sample</b><br>Inject sample into titration cell through septum or needle hole of three-hole adapter with 1 mL or 10 mL syringe.   |
| L3 | Injection with syringe after cooling sample<br>(with needle Ø 0.8 mm)        | <b>Boiling point 5 - 15 °C</b><br>- Cool sample to approx. 0°C in ice bath.<br>- Inject sample into titration cell through septum or needle hole of three-hole adapter with 1 mL or 10 mL syringe.   |
| L4 | Injection with syringe   | <b>Hygroscopic sample or low moisture content (&lt; 1000 ppm)</b><br>- Keep sample in a septum flask.<br>- Inject sample into titration cell through septum or needle hole of three-hole adapter with 10 mL syringe (with needle Ø 0.8 mm).<br>- Rinse syringe with sample 2-3 times (pull up and discard) and condition for 5 minutes.<br>- The pressure loss during sample removal must be compensated with dried air. |
| L5 | Injection with syringe   | <b>Samples with high moisture content (&gt; 50%)</b><br>- Rinse syringe with sample 2-3 times.<br>- For each titration use 1 mL syringe (with needle Ø 0.8 mm) to remove fresh sample from sample flask and inject this into titration cell through septum or needle hole of three-hole adapter.   |
| L6 | Injection with syringe after sample homogenization<br>(with needle Ø 0.8 mm) | <b>Inhomogeneous emulsions</b><br>- Homogenize thoroughly by shaking or stirring prior to sample removal.<br>- Remove sample immediately.<br>- Inject sample into titration cell through septum or needle hole of three-hole adapter with 1 mL or 10 mL syringe.   |

### 11.4.5 Accessories for sample input

|                      |        |             |                    |          |
|----------------------|--------|-------------|--------------------|----------|
| Syringe              | 1 mL   | ME-71492    | 10 mL              | ME-71482 |
| Injection needle     | 1.2 mm | ME-71483    | 0.8 mm             | ME-71484 |
| Weighing boat, glass |        | ME-23951    | Septum NS24        | ME-23950 |
| Visco-Spoon™         |        | ME-51107668 | Three-hole adapter | ME-23982 |

### 11.4.6 References

- [1] FISCHER, K., „Neues Verfahren zur massanalytischen Bestimmung des Wassergehaltes von Flüssigkeiten und festen Körpern“, *Angew. Chem.* 48, 394 - 396 (1935).
- [2] WERNIMONT, G.; HOPFKINSON, F.J., „The Dead-Stop End Point – As Applied to the Karl Fischer Method for Determining Moisture“, *Ind. Eng. Chem., Anal. Ed.* 15 (4), 272 – 274 (1943).
- [3] See literature references in:  
EBERIUS, E., „Wasserbestimmung mit Karl-Fischer-Lösung“, 1. Auflage, Verlag Chemie Weinheim (1954) / (in German).
- [4] MEYER, A.S.; BOYD, C. M., „Determination of Water by Titration with Coulometrically Generated Karl Fischer Reagents“, *Anal. Chem.* 31 (2), 215 – 219 (1959).
- [5] BUNSEN, R.W., *Liebigs Ann. Chem.* 86, 265 (1853).
- [6] SMITH, D.M.; W. M. BRYANT; J. MITCHELL jr., „Analytical Procedures Employing Karl Fischer Reagent I. Nature of the Reagent“, *J. Amer. Chem. Soc.* 61, 2407 - 2412 (1939).
- [7] VERHOFF, J.C.; E. BARENDRECHT, „Mechanism and reaction rate of the Karl Fischer titration reaction. Part I. Potentiometric measurements“, *J. Electroanal. Chem.* 71, 305-315 (1976).
- VERHOFF, J.C.; E. BARENDRECHT, „Mechanism and reaction rate of the Karl Fischer titration reaction. Part II. Rotating ring disk electrode measurement“, *J. Electroanal. Chem.* 75, 705-717 (1976).
- VERHOFF, J.C.; E. BARENDRECHT, „Mechanism and reaction rate of the Karl Fischer titration reaction. Part V. Analytical implications“, *Anal. Chim. Acta.* 94, 395-403 (1977).
- VERHOFF, J.C.; KOK, W. Th., „Mechanism and reaction rate of the Karl Fischer titration reaction. Part III. Rotating ring disk electrode measurement - comparison with the aqueous system“, *J. Electroanal. Chem.* 86, 407-415 (1978).
- VERHOFF, J.C.; COFINO, W. P., „Mechanism and reaction rate of the Karl Fischer titration reaction. Part IV. First and second order catalytic currents at a rotating disk electrode“, *J. Electroanal. Chem.* 93, 75-80 (1978).
- [8] SCHOLZ, E., „Karl-Fischer Reagentien ohne Pyridin“, *Fresenius Z. Anal. Chem.* 303, 203 - 207 (1980).
- SCHOLZ, E., „Karl-Fischer Reagentien ohne Pyridin Genauigkeit der Wasserbestimmung“, *Fresenius Z. Anal. Chem.* 306, 394 - 396 (1981).
- SCHOLZ, E., „Karl-Fischer Reagentien ohne Pyridin. Einkomponenten Reagentien“, *Fresenius Z. Anal. Chem.* 309, 30-32 (1981).
- SCHOLZ, E., „Karl-Fischer Reagentien ohne Pyridin. Neue Eichsubstanzen“, *Fresenius Z. Anal. Chem.* 309, 123-125 (1981).
- SCHOLZ, E., „Karl-Fischer Reagentien ohne Pyridin. Zweikomponenten Reagentien mit Imidazol“, *Fresenius Z. Anal. Chem.* 312, 460-464 (1982).
- [9] WÜNSCH, G; SEUBERT A., „Stöchiometrie und Kinetik der Karl-Fischer –Reaktion in Methanol als Reaktionsmedium“, *Fres. Z. Anal. Chem.* 334, 16-21 (1989) (in German).
- SEUBERT A.; WÜNSCH, G; „Nebenreaktionen in Karl-Fischer-Reagenzien“, *Fres. Z. Anal. Chem.* 334, 256-260 (1989) (in German).
- Both publications from:  
SEUBERT, A., „Untersuchungen zur Karl-Fischer-Reaktion“, Diploma-Thesis at the University of Hannover / Germany, 1988 (in German).
- [10] GRÜNKE, S.; WÜNSCH, G., „Kinetics and stoichiometry in the Karl Fischer solution“, *Fresenius J. Anal. Chem* 368, 139-147 (2000).
- GRÜNKE, S., „Reaktionsmechanismen in der Karl-Fischer-Lösung“, PhD. Thesis University of Hannover, 1999 (in German).

- [11] LANZ, M., DE CARO C.A., RÜEGG K., DE AGOSTINI A., "Coulometric Karl Fischer titration with a diaphragm-free cell: Cell design and applications", Food Chemistry 96, 431-435 (2006).

## 11.5 Additional literature

HYDRANAL®-Manual, „Eugen Scholz Reagents for Karl Fischer Titration“, Sigma-Aldrich Laborchemikalien GmbH, D- 30918 Seelze / Germany, 2006.

SCHOLZ. E., „Karl Fischer Titration“, Springer Verlag Berlin, 1984.

WIELAND, G., „Wasserbestimmung durch Karl-Fischer-Titration - Theorie und Praxis“, GIT Verlag GmbH, Darmstadt / Germany, 1985.

SCHÖFFSKI, K., „Untersuchungen einer Karl-Fischer-Reaktion“; Diploma-Thesis at the University of Hannover / Germany, 1989 (German)

## 12 Appendix

### 12.1 Formula for the external extraction

Principle:

- The water amount (in grams) *after extraction* is equal to the water amount *before extraction*.
- The sample P used for the extraction is **not** dissolved.

Water amount after extraction = Water amount before extraction

$$W_{\text{TOT}} \cdot (m_L + (m_P \cdot W_P)) = W_P \cdot m_P + W_L \cdot m_L$$

where

|                    |  |             |
|--------------------|--|-------------|
| $W_P$ :            | Water content in the sample P (% or ppm).                      | <b>R</b>    |
|                    | This is what we get from the calculation in the KF method.     |             |
| $W_{\text{TOT}}$ : | Water content of the supernatant extraction solvent (% or ppm) | <b>C</b>    |
| $W_L$ :            | Blank value (water content of the solvent, % or ppm).          | <b>B</b>    |
| $m_L$ :            | Amount of solvent (g) after determining the blank value        | <b>msol</b> |
| $m_P$ :            | Amount of sample (g) extracted with the solvent                | <b>mext</b> |

Thus:

$$1) \quad C \cdot [msol + (mext \cdot R)] = R \cdot mext + B \cdot msol$$

$$2) \quad C \cdot msol + C \cdot mext \cdot R = R \cdot mext + B \cdot msol$$

$$3) \quad C \cdot mext \cdot R - R \cdot mext = B \cdot msol - C \cdot msol$$

$$4) \quad R \cdot (C \cdot mext - mext) = B \cdot msol - C \cdot msol$$

$$5) \quad R = \frac{1}{(mext \cdot (C - 1))} \cdot (B \cdot msol - C \cdot msol)$$

$$6) \quad R = \frac{1}{(mext \cdot (1 - C))} \cdot (C \cdot msol - B \cdot msol) \quad \text{since} \quad \frac{1}{1 - C} = -\frac{1}{C - 1}$$

$$7) \quad R = \frac{1}{1 - C} \cdot \left( C \cdot \frac{msol}{mext} - \frac{B \cdot msol}{mext} \right)$$

$$\text{For \% :} \quad R(\%) = \frac{100}{100 - C} \cdot \left( C \cdot \frac{msol}{mext} - \frac{B \cdot msol}{mext} \right) \quad \text{since } 1 = 100\%,$$

$$\text{For ppm :} \quad R(\text{ppm}) = \frac{10^6}{10^6 - C} \cdot \left( C \cdot \frac{msol}{mext} - \frac{B \cdot msol}{mext} \right) \quad \text{since } 1 = 10^6 \text{ ppm.}$$

## 12.2 Formula for the external dissolution

Principle:

- The water amount (in grams) determined by titration is the sum of the water amounts present in the solvent and in the sample.
- The sample P used for the external dissolution is **completely dissolved** into the solvent. Thus, the total volume is increased.

Water amount after dissolution = Water amount before before dissolution

$$W_{\text{TOT}} \cdot (m_L + m_P) = W_P \cdot m_P + W_L \cdot m_L$$

where

|                    |  |             |
|--------------------|--|-------------|
| $W_P$ :            | Water content in the sample P (% or ppm)<br>This is what we get from the calculation in the KF method. | <b>R</b>    |
| $W_{\text{TOT}}$ : | Total water content (sample + solvent), in % or ppm.   | <b>C</b>    |
| $W_L$ :            | Blank value (water content in% or ppm) of the solvent.   | <b>B</b>    |
| $m_L$ :            | Amount of solvent (g) after determining the blank value  | <b>msol</b> |
| $m_P$ :            | Amount of sample (g) extracted with the solvent  | <b>mext</b> |

Thus:

$$1) \quad C \cdot [msol + mext] = R \cdot mext + B \cdot msol$$

$$2) \quad C \cdot msol + C \cdot mext = R \cdot mext + B \cdot msol$$

$$3) \quad R \cdot mext = C \cdot msol + C \cdot mext - B \cdot msol$$

$$4) \quad R = C \cdot \left( \frac{msol + mext}{mext} \right) - \left( \frac{B \cdot msol}{mext} \right)$$

$$\text{For \% and ppm:} \quad R(\%, \text{ppm}) = C \cdot \left( \frac{msol + mext}{mext} \right) - \left( \frac{B \cdot msol}{mext} \right)$$

## 12.3 Standards for Karl Fischer coulometry

a) For direct measurements:

VWR/VWR/MERCK APURA water standard 0.01%

VWR/VWR/MERCK APURA water standard 0.1%

SIGMA-ALDRICH HYDRANAL®-Water Standard 0.1 mg/g (100 ppm)

SIGMA-ALDRICH HYDRANAL®-Water Standard 1.00 mg/g (1000 ppm)

b) For measurements with an oven:

VWR/VWR/MERCK APURA Water standard oven 1% (tungstate)

SIGMA-ALDRICH HYDRANAL®-Water Standard KF-Oven 5.55%  
(potassium citrate monohydrate)

The water content is declared on a test certificate supplied with every vial.

## 12.4 Reagents and solvents for coulometric analysis

To determine its total water content, the sample must completely dissolve in the anolyte. If the sample does not completely dissolve, an emulsion is formed. In this case, part of the water content is not measured, i.e. the water content determined is lower than the actual water content of the sample.

This means that if an emulsion is formed in the anolyte, the anolyte must be immediately replaced.

A number of different anolytes are available to dissolve the various types of samples encountered in practice. Alternatively, more solvent can be added to the anolyte.

### 12.4.1 For samples that are soluble in methanol or ethanol

These include: hydrocarbons (up to C10), chlorinated hydrocarbons (up to C10), alcohols, ethers, esters, nitrocompounds, acetamide, etc.

*For cells with diaphragm:*

- Methanol-based reagents:  
anolyte:  
HYDRANAL® Coulomat AG (SIGMA-ALDRICH)  
APURA combiCoulomat frit (VWR/VWR/MERCK)  
catholyte:  
HYDRANAL® Coulomat CG (SIGMA-ALDRICH)  
APURA combiCoulomat frit (VWR/VWR/MERCK)
- Ethanol-based reagents:  
anolyte:  
HYDRANAL® Coulomat E (SIGMA-ALDRICH)  
catholyte: HYDRANAL® Coulomat E (SIGMA-ALDRICH)

*For cells without diaphragm:*

- Methanol-based reagents:  
electrolyte: HYDRANAL® Coulomat AD (SIGMA-ALDRICH)

APURA combiCoulomat fritless (VWR/VWR/MERCK)

### 12.4.2 For samples that are poorly soluble in methanol or ethanol

These include: etherial oils, edible oils, ointments, hydrocarbons (C10 to C20), etc.

Octanol or hexanol can be added to the anolyte to improve the solubility of these samples. This is limited to a maximum of 30% to prevent the conductivity from falling too low.

*For cells with diaphragm:*

- Methanol-based reagents:  
anolyte:  
HYDRANAL® Coulomat AG-H (SIGMA-ALDRICH)  
contains approx. 30% hexanol  
APURA combiCoulomat frit (VWR/VWR/MERCK) + 30% hexanol  
catholyte:  
HYDRANAL® Coulomat CG (SIGMA-ALDRICH)  
APURA combiCoulomat frit

*For cells without diaphragm:*

- Methanol-based reagents:  
electrolyte:  
HYDRANAL® Coulomat AD (SIGMA-ALDRICH) + 20% hexanol  
APURA CombiCoulomat fritless (VWR/VWR/MERCK) + 20% hexanol

### 12.4.3 For samples that are insoluble in methanol or ethanol

These include: petroleum oils, transformer oils, silicone oils, hydrocarbons (above C20), etc.

Chloroform must be added to the anolyte to ensure the solubility of these samples. This is limited to a maximum of 30% in order to prevent the conductivity from becoming too low.

*For cells with diaphragm:*

- Methanol-based reagents:  
anolyte:  
HYDRANAL® Coulomat A (SIGMA-ALDRICH) + 20% chloroform  
HYDRANAL® Coulomat AG (SIGMA-ALDRICH) + 30% chloroform  
APURA combiCoulomat frit (VWR/VWR/MERCK) + 30% chloroform  
catholyte:  
HYDRANAL® Coulomat CG (SIGMA-ALDRICH)  
APURA combiCoulomat frit (VWR/VWR/MERCK)

*For cells without diaphragm:*

- Methanol-based reagents:  
electrolyte:  
HYDRANAL® Coulomat AD (SIGMA-ALDRICH) + 30% chloroform  
APURA combiCoulomat fritless (VWR/VWR/MERCK) + 30% chloroform

### 12.4.4 For ketones and aldehydes

Ketones and aldehydes react with methanol to form a ketal or an acetal and water.

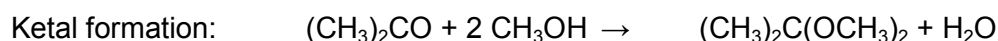
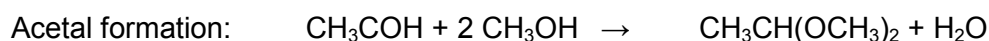

Special methanol-free reagents must be used for these substances.

*For cells with diaphragm:*

- Methanol-free reagents:  
anolyte:  
HYDRANAL® Coulomat AK (SIGMA-ALDRICH)  
catholyte:  
HYDRANAL® Coulomat CG-K (SIGMA-ALDRICH)

*For cells without diaphragm:*

- Methanol-free reagents:  
electrolyte:  
HYDRANAL® Coulomat AK (SIGMA-ALDRICH)

Notes on ketones:

- When changing from normal KF anolytes to ketone reagents, the entire titration cell must be thoroughly cleaned because even traces of methanol may cause serious interferences.
- If you measure ketones regularly, we recommend the use of a second titration cell.



- If you have titrated a number of ketone samples, the drift is higher because of the very slow side reaction. After a longer standby period, it is possible that the anolyte is exhausted after a few days even though no further titrations have been performed.
- Choose relatively small samples (approx. 1 mL); with reactive ketones such as cyclohexanone use only 0.2 mL to 0.5 mL. The larger the sample, the more important the effect of side reactions becomes, i.e. the drift increases from sample to sample so strongly that the determination of the endpoint becomes difficult.
- The special reagent for ketones can also be used for other samples. It is important to note that alcohols that react with ketones should not be titrated in this reagent.

Notes on aldehydes:

- Short chain aldehydes (e.g. acetaldehyde) are oxidized at the anode with the formation of water. Coulometric KF titration cannot be used to determine these compounds; the substances can, however, easily be measured with volumetric KF determination.
- Aromatic aldehydes (e.g. benzaldehyde) can also be determined by coulometric KF titration. It should be noted that the bisulfide-addition reaction is very strong with aromatic aldehydes. This is why one should wait for the reverse cleavage reaction of the bisulfide compound before aborting the titration (ensure that the drift drops down again to the initial value).

#### 12.4.5 For acids and bases (pH value)

A noisy titration or a sluggish end point can indicate a pH shift. In these cases the pH value of the anolyte should be measured.

- Measure the pH with a glass electrode adjusted with aqueous buffers. To do this, take an aliquot of anolyte from the titration cell. The measurement should not be performed in the titration cell because the electrode introduces too much water.
- Measurement with moistened indicator paper also gives an approximate indication of the pH value of the anolyte.
- With Karl Fischer titrations of acidic and basic samples, the pH value of the anolyte must be adjusted to the range 5.5 to 7 (see Section 1.2).

*For acidic samples, e.g. acetic acid, formic acid, etc.:*

- Use the HYDRANAL® buffer (SIGMA-ALDRICH). The use of imidazole increases the pH value in the anolyte.
- Fill the anode compartment with approx. 80 mL of anolyte and 20 mL HYDRANAL® buffer.

*For basic samples, e.g. amines:*

- Basic samples must be neutralized with salicylic acid or benzoic acid.
- Fill the anode compartment with approx. 90 mL of anolyte and 5 g salicylic acid or benzoic acid.

## 12.5 Water Standards for Karl Fischer volumetric titration

a) For direct measurements:

VWR/VWR/MERCK APURA® water standard 0.1%

VWR/VWR/MERCK APURA® water standard 1%

SIGMA-ALDRICH HYDRANAL®-Water Standard 1.0 mg/g (1000 ppm)

SIGMA-ALDRICH HYDRANAL®-Water Standard 10.0 mg/g (10'000 ppm)

b) For measurements with an oven:

VWR/VWR/MERCK APURA Water standard oven 1% (tungstate)

SIGMA-ALDRICH HYDRANAL®-Water Standard KF-Oven 5.55%  
(potassium citrate monohydrate).

The water content is declared on a test certificate supplied with every vial.

## 12.6 Titrants and solvents for volumetric analysis

The sample must be completely dissolved in the anolyte to determine the total water content. If it does not completely dissolve, an emulsion is formed. In this case, part of the water content is not measured, i.e. the result determined is lower than the actual water content. In this case, the anolyte must be immediately replaced.

A number of different anolytes are available to dissolve the various types of samples encountered in practice. Alternatively, more solvent can be added to the anolyte

### 12.6.1 For samples soluble in methanol or ethanol

These include: hydrocarbons (to C<sub>10</sub>), chlorinated hydrocarbons (to C<sub>10</sub>), alcohols, ethers, esters, nitrocompounds, acetamide, etc.

*One-component reagents:*

- Methanol-based:

  Titrant:

                  HYDRANAL® Composite                   (SIGMA-ALDRICH)

                  apura® CombiTitrant                   (VWR/Merck)

  Solvent:

                  Dry methanol

*Two-component reagents:*

- Methanol-based:

  Titrant:

                  HYDRANAL® Titrant                   (SIGMA-ALDRICH)

                  apura® Titrant                   (VWR/Merck)

  Solvent:

                  HYDRANAL® Solvent

- Ethanol-based:

  Titrant:

                  HYDRANAL® Titrant E               (SIGMA-ALDRICH)

  Solvent:

                  HYDRANAL® Solvent E               (SIGMA-ALDRICH)

### 12.6.2 For samples poorly soluble in methanol or ethanol

These include: etherial oils, edible oils, ointments, hydrocarbons (C<sub>10</sub> to C<sub>20</sub>), etc.

Octanol or hexanol can be added to the anolyte to improve the solubility of these samples. This is limited to a maximum of 50%.

*One-component reagents:*

- Methanol-based:  
 Titrant:
 

|  |                                |
|--|--------------------------------|
| HYDRANAL® Composite<br>apura® CombiTitrant | (SIGMA-ALDRICH)<br>(VWR/Merck) |
|--|--------------------------------|

  
 Solvent:
 

|   |                                |
|---|--------------------------------|
| HYDRANAL® LipoSolver CM, MH<br>apura® CombiSolvent Fats | (SIGMA-ALDRICH)<br>(VWR/Merck) |
|---|--------------------------------|

*Two-component reagents:*

- Methanol-based:  
 Titrant:
 

|                                     |                                |
|-------------------------------------|--------------------------------|
| HYDRANAL® Titrant<br>apura® Titrant | (SIGMA-ALDRICH)<br>(VWR/Merck) |
|-------------------------------------|--------------------------------|

  
 Solvent:
 

|  |                                |
|--|--------------------------------|
| HYDRANAL® Solvent CM, Oil<br>apura® Solvent Oil & Fats | (SIGMA-ALDRICH)<br>(VWR/Merck) |
|--|--------------------------------|

**12.6.3 For samples insoluble in methanol or ethanol**

These include: petroleum oils, transformer oils, silicone oils, hydrocarbons (above C20), etc.

Chloroform must be added to the anolyte to ensure the solubility of these samples. This is limited to a maximum of 50% in order to prevent the conductivity from becoming too low.

*One-component reagents:*

- Methanol-based:  
 Titrant:
 

|  |                                |
|--|--------------------------------|
| HYDRANAL® Composite<br>apura® CombiTitrant | (SIGMA-ALDRICH)<br>(VWR/Merck) |
|--|--------------------------------|

  
 Solvent:
 

|  |             |
|--|-------------|
| HYDRANAL® Solver (Crude)<br>apura® CombiSolvent Fats | (VWR/Merck) |
|--|-------------|

*Two-component reagents:*

- Methanol-based:  
 Titrant:
 

|                                     |                                |
|-------------------------------------|--------------------------------|
| HYDRANAL® Titrant<br>apura® Titrant | (SIGMA-ALDRICH)<br>(VWR/Merck) |
|-------------------------------------|--------------------------------|

  
 Solvent:
 

|  |                                |
|--|--------------------------------|
| HYDRANAL® Solvent CM, Oil<br>apura® Solvent Oil & Fats | (SIGMA-ALDRICH)<br>(VWR/Merck) |
|--|--------------------------------|

**12.6.4 For ketones and aldehydes**

Ketones and aldehydes react with methanol to form a ketal, or an acetal, with the formation of water.

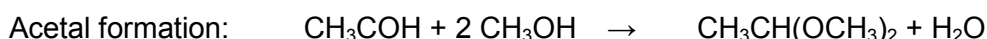

Special methanol-free reagents must be used for these substances.

*One-component reagents:*

- Methanol-free:  
Titrant:
 

|                            |                 |
|----------------------------|-----------------|
| HYDRANAL® Composite 5 K    | (SIGMA-ALDRICH) |
| apura® CombiTitrant 5 Keto | (VWR/Merck)     |
- Solvent:
 

|                            |                 |
|----------------------------|-----------------|
| HYDRANAL® Medium K         | (SIGMA-ALDRICH) |
| HYDRANAL® Working Medium K |                 |
| HYDRANAL® KetoSolver       |                 |
| apura® CombiSolvent Keto   | (VWR/Merck)     |

#### Notes on ketones:

- When changing to ketone reagents, the entire titration cell must be thoroughly cleaned because even traces of methanol can cause serious interference.
- If you measure ketones regularly, we recommend the use of a second titration cell.
- If you have titrated a number of ketone samples, the drift is higher because of the very slow side reaction.
- Choose relatively small samples (approx. 1 mL); with reactive ketones such as cyclohexanone use only 0.2 mL to 0.5 mL. The larger the sample, the more important the effect of side reactions becomes, i.e. the drift increases from sample to sample so strongly that the determination of the endpoint becomes difficult.
- The special reagent for ketones can also be used for other samples. It is important to note that alcohols that react with ketones should not be titrated in this reagent.

#### Notes on aldehydes:

- Short chain aldehydes (e.g. acetaldehyde) are oxidized at the anode with the formation of water. Coulometric KF titration cannot be used to determine these compounds; the substances can, however, easily be measured with volumetric KF determination.
- Aromatic aldehydes (e.g. benzaldehyde) can also be determined by coulometric KF titration. It should be noted that the bisulfide-addition reaction is very strong with aromatic aldehydes. This is why one should wait for the reverse cleavage reaction of the bisulfide compound before aborting the titration (ensure that the drift drops down again to the initial value).

### 12.6.5 For acids and bases (pH value)

A noisy titration or a sluggish end point can indicate a pH shift. In these cases the pH value of the analyte should be measured.

- Measure the pH with a glass electrode adjusted with aqueous buffers. To do this, take an aliquot of analyte from the titration cell. The measurement should not be performed in the titration cell because the electrode introduces too much water.
- Measurement with moistened indicator paper also gives an approximate indication of the pH value of the analyte.
- With Karl Fischer titrations of acidic and basic samples, the pH value of the analyte must be adjusted to the range 5.5 to 7 (see Section 1.2).

*For acidic samples, e.g. acetic acid, formic acid, etc.:*

- Use the HYDRANAL® buffer (SIGMA-ALDRICH). The use of imidazole leads to a high pH value in the analyte.
- Fill the anode compartment with approx. 80 mL of analyte and 20 mL HYDRANAL® buffer.

*For basic samples, e.g. amines:*

- Basic samples must be neutralized with salicylic acid or benzoic acid.
- Fill the anode compartment with approx. 90 mL of anolyte and 5 g salicylic acid or benzoic acid.

## 13 Hazards and waste disposal tips

### 13.1 One-component reagent

Composition: sulfur dioxide, iodine, buffer (imidazole) and solvent (methanol, 2-methoxyethanol or diethyleneglycolmonomethylether).

Safety: flammable to extremely flammable. Irritant when inhaled. Health hazard when inhaled, swallowed or allowed to contact skin. Keep container tightly closed. Keep away from open flames or sparks. Do not let reagent contact skin or eyes.

Disposal: as an organic solvent.

### 13.2 Two-component reagent:

Composition: iodine and solvent (methanol, 2-methoxyethanol, xylene or trichloroethaylene).

The KF solvent contains: sulfur dioxide, buffer (imidazole) and solvent (methanol, 2-methoxyethanol or diethyleneglycolmonomethylether).

Safety: flammable to extremely flammable. Irritant when inhaled. Health hazard when inhaled, swallowed or allowed to contact skin. Keep container tightly closed. Keep away from open flames or sparks. Do not let reagent contact skin or eyes.

Disposal: as an organic solvent.

### 13.3 Reagents for coulometry:

Composition: iodine, sulfur dioxide, buffer (imidazole), and solvent (methanol, chloroform, tetrachloromethane, 2-methoxyethanol).

Safety: Highly flammable. Skin irritant, poisonous when inhaled or swallowed. Keep container tightly closed and far removed from open flames or sparks. Do not let reagent contact skin or eyes.

Disposal: as an organic solvent.

### 13.4 Safety data for the KF-components and auxiliary solvents:

|                                       |  |
|---------------------------------------|--|
| sulfur dioxide:                       | MAK-value: 200 ppm   |
| iodine:                               | MAK-value: 0.1 ppm, oxidant  |
| diethyleneglycol-<br>monomethylether: | Ignition temp.: 87 °C  |
| 2-methoxyethanol:                     | Ignition temp.: 46 °C    MAK value: 5 ppm<br>Flammable. Potential teratogen. Health hazard when inhaled,<br>swallowed or allowed to contact skin. Irritant when inhaled. |
| methanol:                             | Ignition temp.: 11 °C    MAK value: 200 ppm<br>Highly flammable. Poisonous when inhaled or swallowed.  |
| o-xylene:                             | Ignition temp.: 28 °C    MAK value: 100 ppm<br>Flammable. Health hazard upon inhalation.   |
| chloroform:                           | Ignition temp.: does not burn    MAK vlaue: 200 ppm  |

1-decanol: Health hazard when inhaled. Irreversible damage possible.  
Ignition temp.: 95 °C Irritant for skin and eyes.

formamide: Ignition temp.: inflammable MAK value: 20 ppm  
Irritant for skin and eyes. Potential teratogen.

toluene: Ignition temp.: 6°C MAK value: 20 ppm  
Extremely flammable. Health hazard upon inhalation



## Good Titration Practice in water determination

Good Titration Practice™ (GTP) in general encompasses three important steps:

1. **Evaluation** of the appropriate titration system (DQ) i.e. evaluation, specification of the analytical requirements and purchase decision
2. **Installation** of the selected analytical system comprising IQ and OQ and training of personnel
3. **Routine** operation including PQ, method validation, development of SOPs and maintenance of the validated state of the analytical system.

This brochure specifically focuses on Good Titration Practice in water determination using coulometric and volumetric Karl Fischer Titration. It outlines specific aspects in developing and maintaining a good routine operation with METTLER TOLEDO Compact Coulometric and Volumetric KF as well as Excellence titrators.

The GTP KF brochure and the application brochure 38 containing dedicated applications on samples from various industry segments, are two powerful tools which are meant to facilitate your daily water determination analyses and to contribute to reliable results over the whole lifetime of your instrument.

[www.mt.com](http://www.mt.com)

For more information

### Mettler-Toledo AG, Analytical

Sonnenbergstrasse 74  
CH-8606 Schwerzenbach, Switzerland  
Tel. +41-44 806 77 11  
Fax +41-44 806 73 50

Subject to technical changes.

© 04/2011 Mettler-Toledo AG

Printed in Switzerland, ME-51725145A

Markt Support AnaChem