



Online Instrumentation

D.O. · pH · CONDUCTIVITY · TSS · NITROGEN · PHOSPHATE ·
COD/TOC/DOC/SAC/BOD · SLUDGE LEVEL

BELMET97

| www.belmet97.hr | info@belmet97.hr | Zagreb, HR/CRO |



a xylem brand

IQ SENSOR NET –

the system for sewage treatment plants and industrial applications

1) IQ Sensor Network: System 2020 XT

- For up to 20 digital IQ sensors
- Ethernet/LAN interface and integrated web server for the easiest network connection
- Storage of log book data, measured values and configuration for additional system security easy and fast via USB stick
- Software upgrade safe and easy to perform for any user via USB interface
- Portable display with excellent readability even in direct sunlight
- Remote power supply

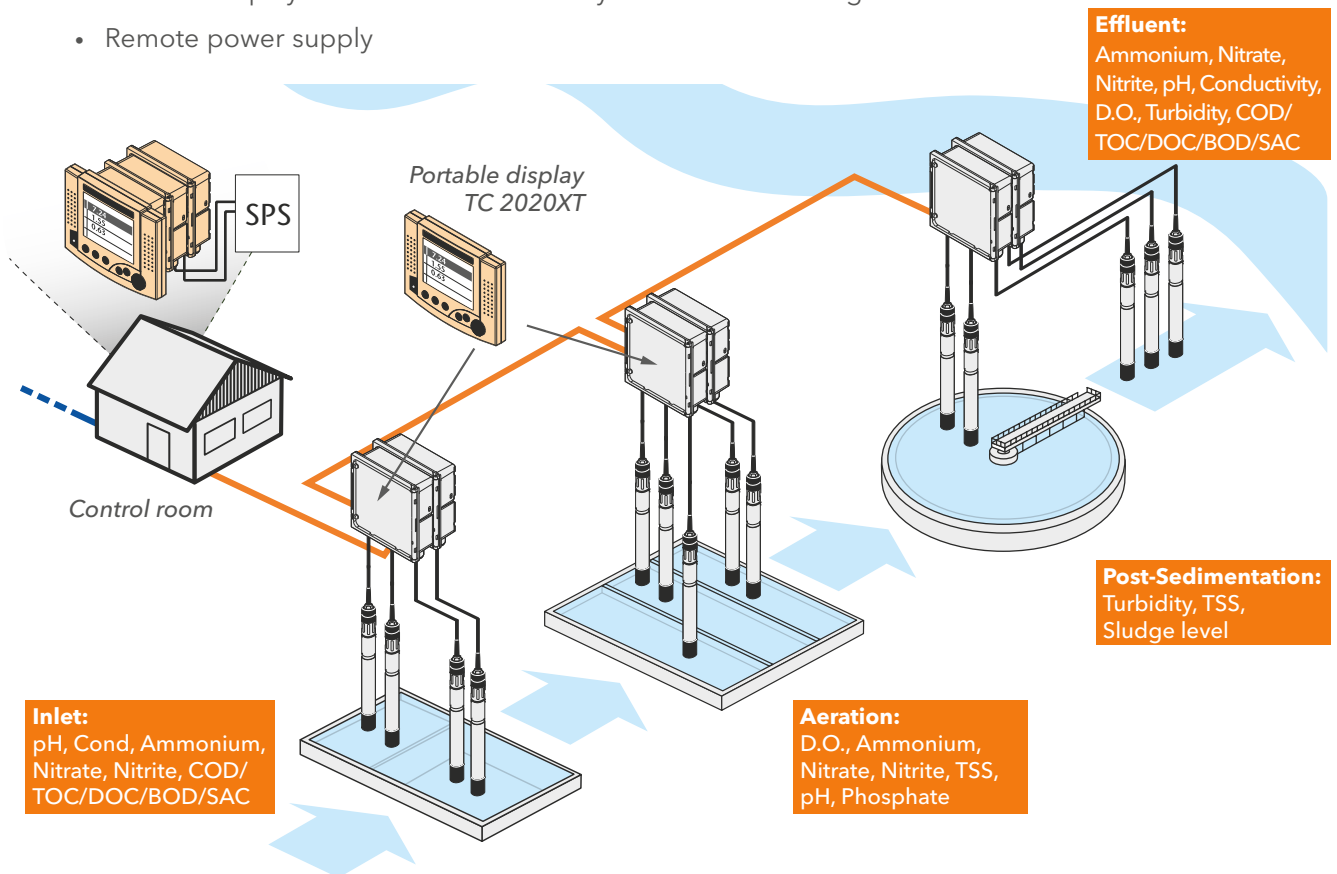

NEW

**Sludge level measurement using IFL 700 IQ
Orthophosphate measurement using P 700 IQ**

2) IQ single measuring point: System 182 XT

- For up to 4 digital IQ sensors
- Best suited for replacing or complementing individual measuring points
- Low-cost entry into digital measuring technology
- Analog version with up to 5 analog outputs and 6 relays

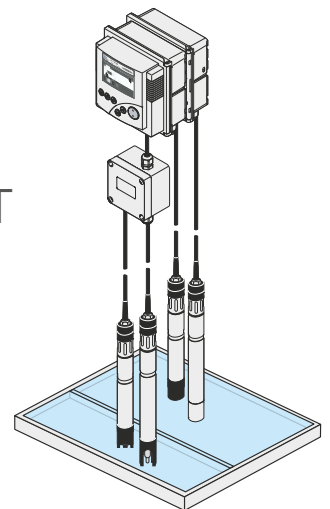

Systems in detail

Modules	MIQ/PS	MIQ/24V	MIQ/C6	MIQ/R6	MIQ/CR3	MIQ/IC2	MIQ/2-MOD	MIQ/2-PR	MIQ/JB	MIQ/JBR	MIQ/Blue PS SET	MIQ/TC2020XT	MIQ/MC2	MIQ/MC2-MOD	MIQ/MC2-PR	Cleaning Air Box - 230 VAC	Cleaning Air Box - 115 VAC	MIQ/CHV PLUS
Usable with System 2020 XT	●	●	●	●	●	●	●	●	●	●	●	●	●	●	●	●	●	●
Usable with System 182	●		●	●	●				●		●					●	●	●
Available IQSN connectors	3	3	2	2	2	2	2	2	4	4	3	×	2	2	2	×	×	2
Power consumption [W]	*	*	3.0	1.5	3.0	0.2	1.6	2.0	0.0	0.2	0.6	3.0	1.6	1.6	2.0	**	**	1.0
Module features																		
Power supply																		
100...240 V AC	●																	
24 V AC/DC		●																
Analog outputs/relays																		
6 x 0/4...20 mA			●															
6 x relays				●														
3 x 0/4...20 mA, 3 x relays					●													
Analog inputs																		
2 x 0/4...20 mA						●												
Interfaces																		
MODBUS							●							●				
PROFIBUS								●								●		
USB							×	×	●				●	●	●			
Ethernet/LAN													●	●	●			
Intra-system connectivity																		
4 available IQSN connectors									●									
4 available IQSN connectors, including signal amplification for large distances										●								
Radio transmission											●							
Controller																		
Controller/Terminal (with Display)												●						
Controller in standard IQ module without display													●	●	●			
Compensation																		
Air-pressure compensation for D.O. measurement						●	●						●	●	●			
Compressed air cleaning																		
Air compressor 230 VAC																	●	
Air compressor 115 VAC																		●
Valve for automatic cleaning																		●

* Power supply 18 W

** Integrated power supply

* USB-interface only for software update

Contents

	page
Publisher	1
New Instruments	2 - 5
New NitraVis®, CarboVis®, NiCaVis® – Spectral sensors	2
Sludge level measurement using IQ SENSOR NET	3
Orthophosphate measurement using IQ SENSOR NET	4
Ethernet/LAN-capable IQ SENSOR NET controller	5
Parameter Section	6 - 73
Dissolved Oxygen	6 - 17
Digital application guide	17
pH/ORP	18 - 27
Digital application guide	27
Conductivity	28 - 33
Digital application guide	33
Turbidity/Suspended Solids	34 - 39
Nitrogen	40 - 56
Carbon: COD/TOC/DOC/SAC/BOD	57 - 61
Phosphate	62 - 69
Sludge level	70 - 73
Systems/Accessories	74 - 135
IQ SENSOR NET	74 - 97
The IQ SENSOR NET System	74 - 79
Overview of the IQ system and IQ sensors	80 - 81
System 2020 XT, USB & Connect	82 - 93
System 182	94 - 97
Monitors EcoLine/QuadroLine®	98 - 103
Analog dissolved oxygen application guide	99
Analog pH/ORP application guide	99
Analog conductivity application guide	100
Analyzer	104 - 111
Sample Preparation	112 - 115
Samplers	116 - 123
Accessories	124 - 135
General Information	136 - 144
Drinking water monitoring	136 - 137
Overview	
“Laboratory and Field Instrumentation”	138 - 139
WTW – About us	140 - 141
Index	143 - 144

Publisher



Wissenschaftlich-Technische
Werkstätten GmbH

Dr.-Karl-Slevogt-Strasse 1
D-82362 Weilheim

Germany

Phone: +49 881 183-0

Fax: +49 881 183-420

E-Mail: Info.WTW@Xylem.com

Internet: www.WTW.com

NEW

The IQ

SENSOR NET^{XT}

WTW Spectral Sensors – Optimized Performance

Chemical-free measurement directly in the wastewater process

Whether inlet, biological tank or effluent, the self-cleaning process sensors NitraVis[®]/CarboVis[®]/NiCaVis[®] are best suited for all applications.

NitraVis[®]/CarboVis[®]/NiCaVis[®] (NI)

- High measurement reliability
- Low operating costs
- Simple handling
- Maximum durability

UV-VIS sensors

NitraVis[®]/CarboVis[®]/
NiCaVis[®]:

- Nitrate
- Carbon parameters
COD, BOD, TOC,
DOC, SAC
- TSS

UV sensors

NiCaVis[®] NI:

- Nitrate
- Carbon parameters
COD, BOD, TOC,
DOC, SAC
- Nitrite

Ultrasonic
Cleaning

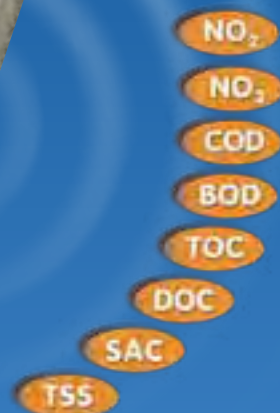

See pages 45, 53 and 54 and from page 57
for additional information.

NEW

New Instruments

is growing ...

Sludge level measurement using the IQ SENSOR NET

IFL 700 IQ

- Intelligent signal processing
- Ready-to-go
- Detailed display of echo profile
- Maintenance-free cleaning system

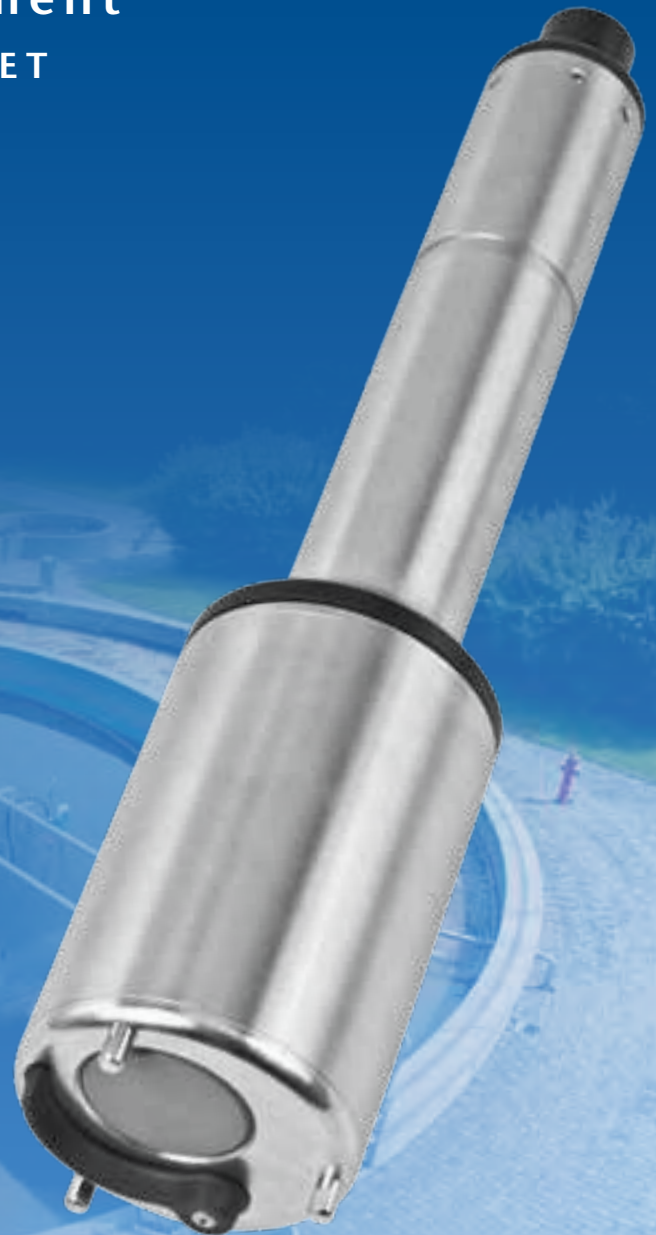

see additional information starting on page 70.

NEW

Orthophosphate Measurement with the new P 700 IQ Analyzer

P 700 IQ

- Low reagent consumption
- Direct connection to the IQ SENSOR NET
- Automatic calibration
- On-site installation

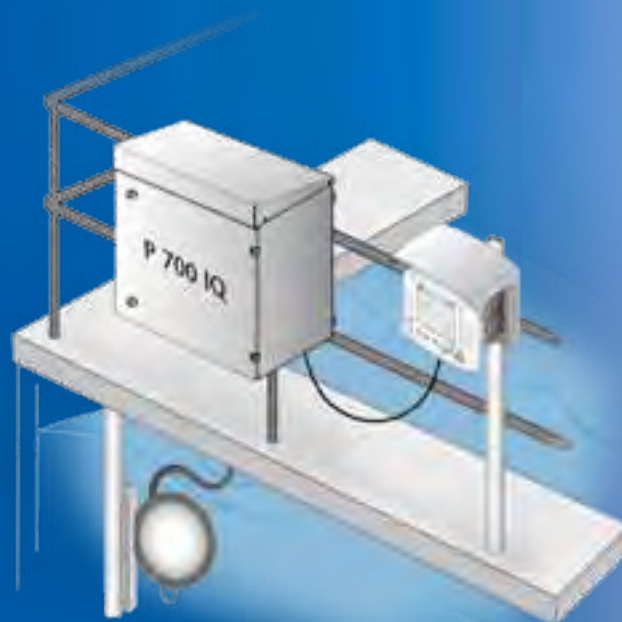

Another component for the IQ SENSOR NET

The P 700 IQ is based on the photometric measurement principle with the proven yellow method (Molybdate-vanadate) and is especially suited for applications in the field of wastewater treatment. The installation is directly performed at the measuring site, and therefore on-site.

PO₄

See additional information starting on page 62.

NEW

New Instruments

IQ SENSOR NET^{XT}

MIQ/MC2

The new controller family MIQ/MC2

The controller modules without a display for the IQ SENSOR NET System 2020 XT are characterized by advanced internet communications options, integrated web servers and easiest software update capabilities.



Housing of the new MIQ/MC2 family with integrated Ethernet/LAN and USB interface

Controller MIQ/MC2

- LAN & USB interface
- Integrated web server
- Various TCP/IP communication protocols
- Profibus and Modbus versions



Using a web browser, measured values of the IQ SENSOR NET web server are displayed

Additional information on pages 88 and 89.

For information visit www.WTW.com for a customer care center near you



Online D.O. Measurement

Measuring · Monitoring · Controlling

Reliable and continuous measurements of dissolved oxygen have become of vital importance in many areas of the water/wastewater treatment facilities. The availability of accurate and timely measured concentration values is an absolute need for process monitoring and dynamic process control to ensure an efficient plant operation.

For more than 50 years now, WTW has been recognized as a leader in the field of Dissolved Oxygen measurements. Innovative technologies, creative and continuous product development, and extensive application expertise have resulted in superior instruments and systems of outstanding performance, reliability and design for the most precise online measurements available. The optical D.O. sensor FDO® 700 IQ combines state-of-the-art technology with application applied benefits.

Online D.O. Measurement

- Water/Wastewater Treatment
- Water Pollution Control
- Fishfarming/Aquaculture

D.O. Monitoring and Control

In the biological nutrient removal process of wastewater treatment plants, continuous and precise measurement of dissolved oxygen concentration is of vital importance to an optimal and trouble free operation of the water/wastewater treatment facility. The efficiency and energy demand of the purification process, either in the nitrification and denitrification phase, is mainly determined by the performance of the aeration control system; i.e., by a load-rate controlled oxygenation in the aeration basin.

In the presence of dissolved oxygen, the nitrifying bacteria convert ammonia to nitrate. The activity of the microorganisms depends on the oxygen concentration, with an economical limit at about 2 mg/l. Higher oxygen concentrations do not increase the rate of degradation, but requires significantly more energy for the oxygen blowers (see illustration).

Controlling the aerator operation to a minimum run time, depending on the required oxygen concentration, helps in saving energy and maintenance costs. This is because the aerator equipment is the most energy consuming part of a biological wastewater treatment plant.

The residual dissolved oxygen in the sludge, however, has a negative effect on the conditions in the denitrification stage. Due to this reason a minimal O_2 concentration in the denitrification is targeted. On the other hand in nitrification, the oxygen concentration is aimed for, ideally covering the requirements for biology. Only the use of precise and reliable on-line measuring instruments will ensure an efficient and energy saving control of the process.

NH_4-N Degradation Rate vs. D.O. Concentration

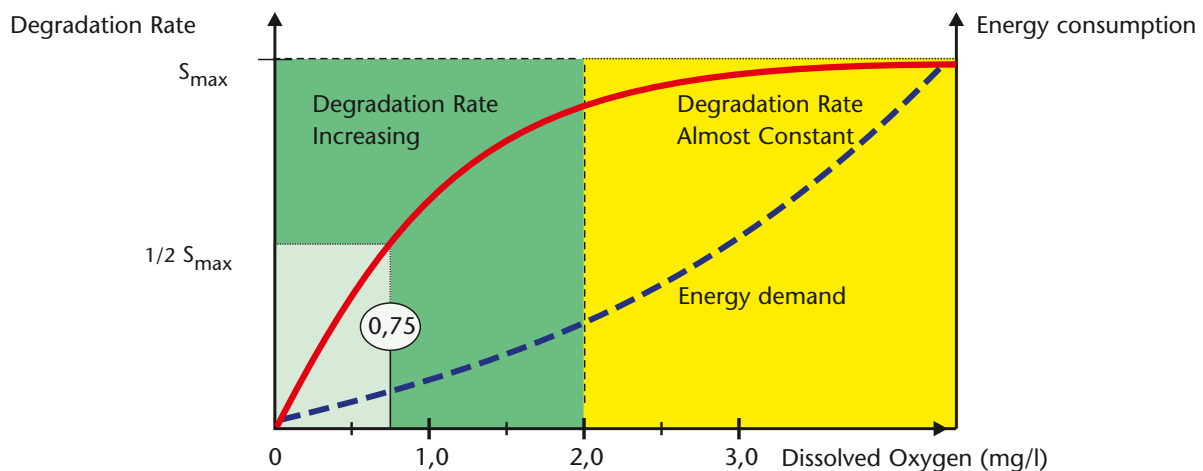

WTW D.O. Measurement Systems

WTW has been continuously designing, manufacturing and satisfying the demands for reliable dissolved oxygen measurements with the most advanced online systems available anywhere.

The WTW product line includes a wide range of precision D.O. sensors and monitors as well as the revolutionary IQ SENSOR NET system so that the optimum system configuration can be chosen for the particular application.

Optical and electrochemical D.O. sensors. Innovative and reliable solutions!

The right choice of measuring technology for D.O. is of essential importance for the performance of the wastewater plant. WTW offers well proven electrochemical and innovative optical D.O. sensors.

The optical sensor FDO® 700 IQ

FDO® 700 IQ

- No incident flow needed
- Insensitive against bubbles
- Low costs of ownership



*Detailed description of the used FDO® technology
is available on pages 10 and 11.*

The electrochemical sensors of the TriOxmatic® series

TriOxmatic® Sensors

- Well proven technology
- Low investment costs
- Self-diagnosis system SensReg/ SensLeck through 3-electrode system

Detailed description of the used techniques of the TriOxmatic® on page 12 and 13.

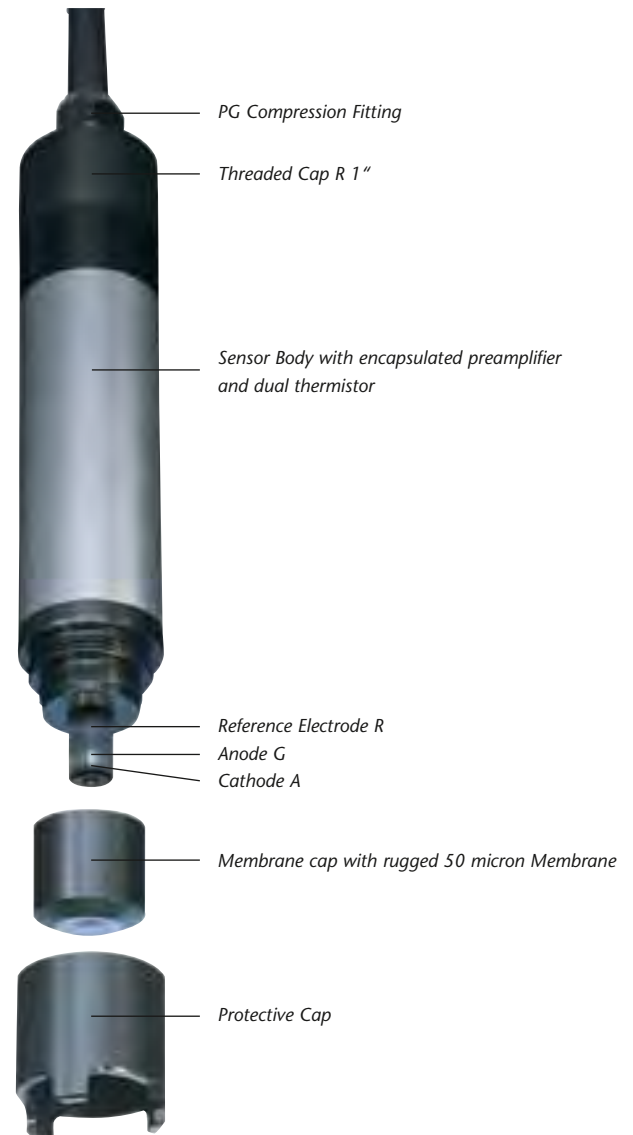

Parameter section

Dissolved Oxygen

pH/ORP

Conductivity

Turbidity/Suspended Solids

Nitrogen

Carbon: COD/TOC/DOC/BOD/SAC

Phosphate

Sludge level

WTW D.O. measuring technology is today's established standard within the water analytics – for both laboratory and online measuring.

FDO[®]: Fluorescence D.O. Measuring – What exactly does this mean?

The optical principle:

With the optical method a fluorescent dye is stimulated in the membrane of the FDO[®] 700 IQ by a short wave length lightsource. By falling back into the passive state, long wave light is emitted, which is recorded as a measurement signal. If oxygen contacts the dye by diffusing through the membrane the period of back scattering light is shortened according to the oxygen concentration of the sample. In principle the measurement of the fluorescent signal come back to a highly precise time measurement.

D.O. sensors of the first generation had a handful of technical issues to cope with.

- Sensor drift through watering impact of the membrane
- Wearing of cye layer in the sensor through highly energetic blue light
- Sensitivity of sensor towards air bubbles

Through consequent development work the difficulties appearing with the first generation sensors could successfully be eliminated with the second generation models.

The following technologies are used:

① IQMC Technology

Each cap is individually factory calibrated. The calibration data are permanently stored on a chip which is installed in the membrane cap.

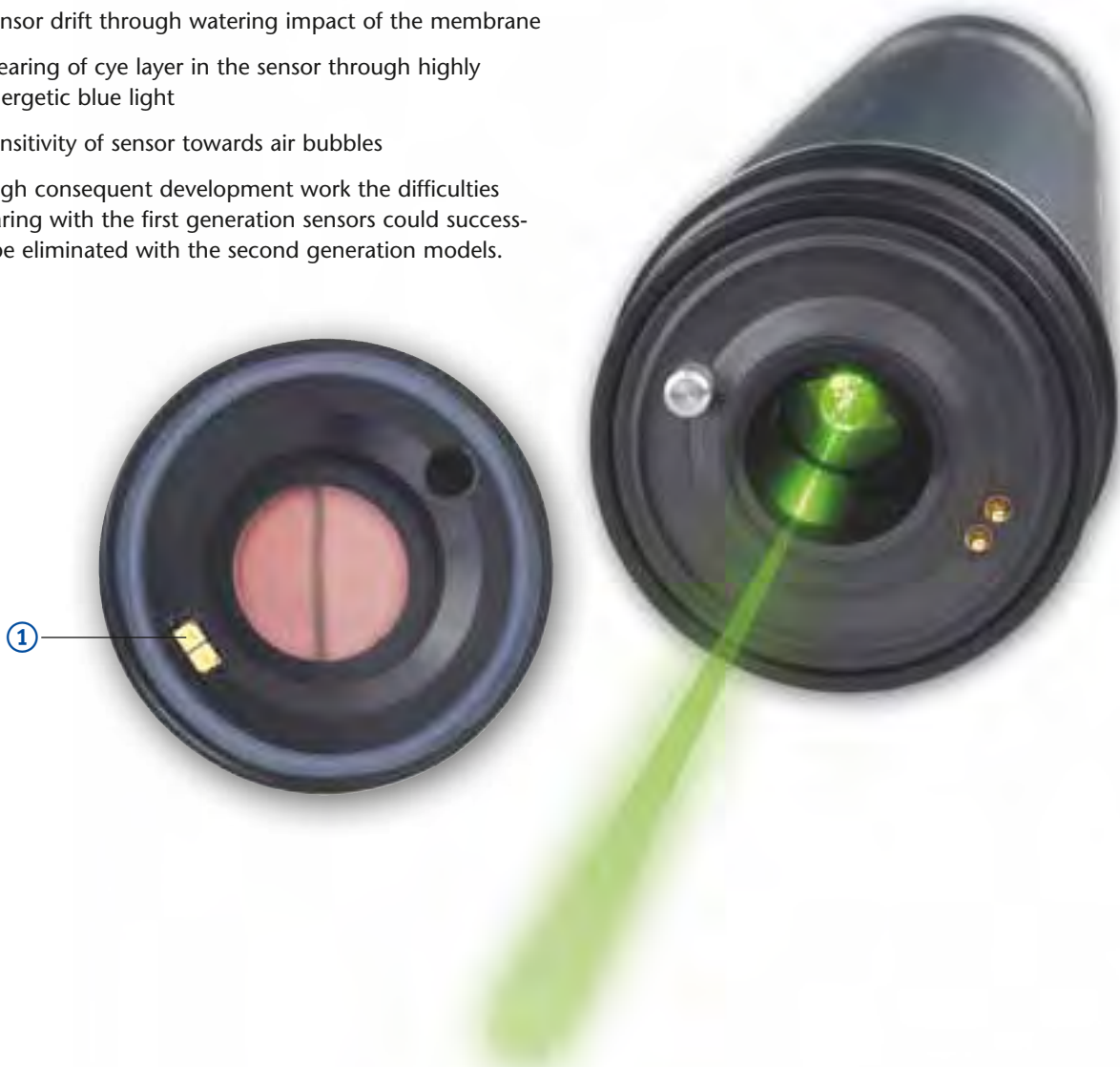

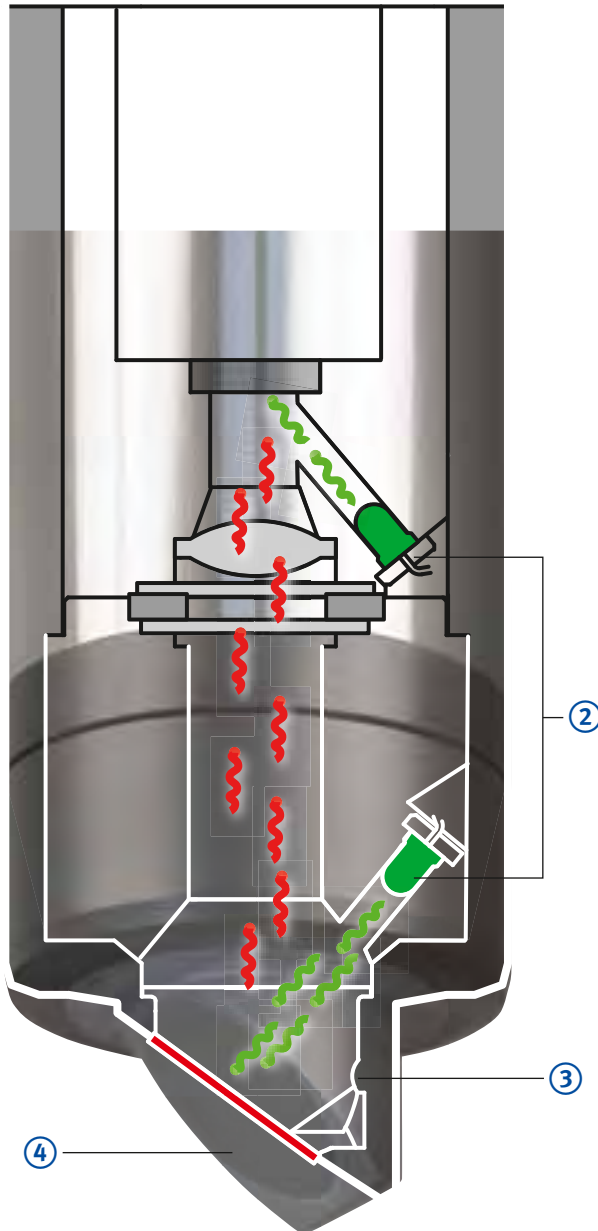

② EPRS = Equal Path Reference System

Measuring and reference path as well as optical components are identically designed with this sensor.

Natural aging processes of the optical components can therefore be compensated by the reference path and accordingly compensated in the measuring path. This causes a continuous high performance of the sensor.

③ GLT = Green-light Technology

By stimulating the fluorescent reaction in the membrane with low energetic green-light, a bleaching of the fluorescent dye in the sensor membrane is avoided. This leads to a membrane lifetime of min. 2 years.

④ 45° Technology

The membrane SC-FDO® has a horizontal slope of 45°. A congestion of air bubbles in front of the membrane, as experienced with the first-generation of optical D.O. sensors, is therefore avoided.

C² calibration:

The optical measuring technology is based on an attenuated fluorescent signal in a defined time frame. The D.O. measuring is more or less a highly precision time measurement. In order to process this time measurement as precise as possible, the sensor optics are calibrated to the speed of light. This natural constant "c" is defined as the time that a light beam needs to go from point A to point B – in short: the speed of light.

The sensor is precisely calibrated against a physical constant.

The interaction of these technologies makes the FDO® a non-calibration sensor.

The TriOxmatic® series (ECDO): proved and tested...

ECDO stands for Electrochemical Dissolved Oxygen Sensor. 60 years ago, Clark's cell was introduced and WTW was among the first manufacturers to advance this principle for water and wastewater applications.

The electrochemical principle

With the electrochemical method the O_2 diffuses through the membrane of the TriOxmatic® sensor. The oxygen is transformed in a chemical reaction by using an electrolyte; thereby a current can be measured. The electrical current correlates to the oxygen concentration. For delivering precise results, the sensor will require the following conditions:

- Flow
- Continuous exchange of electrolytes
- Clean membrane

Linear dependency of current towards the O_2 concentration

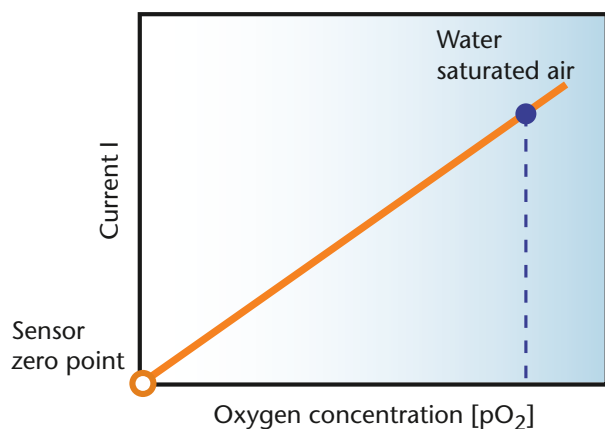

Patented Technology – 3 electrode system

In contrast to conventional membrane covered oxygen sensors equipped with 2-electrode technology, the TriOxmatic® sensor functions with a potentiostatically driven 3-electrode system. In terms of measuring technology, this means that the measuring system has two silver electrodes and a gold cathode (A). One silver functions as a non-current bearing reference electrode (R). And, the other is the live, counter electrode (G). The reference electrode thus displays significantly improved potential constancy, which in turn leads to considerably improved sensor signal stability and thus higher measuring accuracy.

The 3-electrode technology additionally allows precise monitoring of the electrolyte supply, i.e. the system displays when the electrolyte solution needs to be replaced.

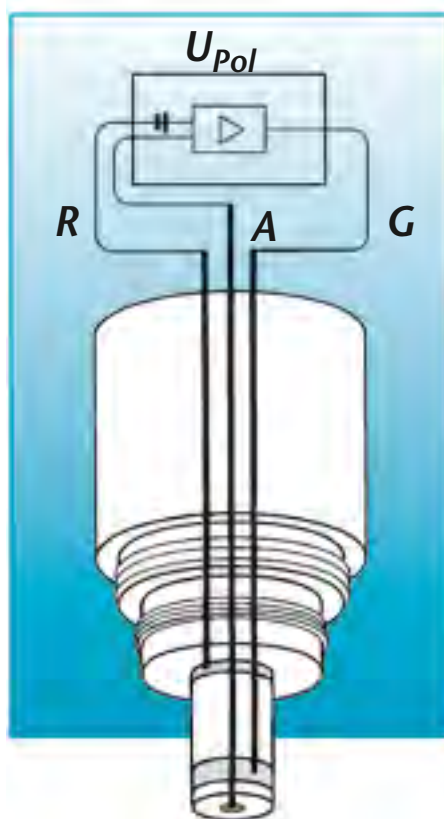

Self-diagnosis system

All parts being relevant for the measurement, such as membranes are automatically monitored by the SensReg (used electrolyte)/SensLeck (leakage in the membrane) system. Any occurring incidents will be shown.

Maintenance-free due to special membrane

The membrane or the membrane cap plays a decisive role in all DO measuring techniques. Fouling or mud covering of the membrane or of the cap will affect the measurement reading. Unlike conventional membranes the teflon membranes used by WTW are highly resistant to fouling. This allows operation without the use of additional cleaning accessories in most cases.

High accuracy

WTW sensors feature extremely low maximum errors of 1 % of the measured value (i.e. 0.02 mg/ml at a measured value of 2 mg/ml), regardless of whether measuring in the upper or in the lower range of the instrument.

Stable readings right from the start

All WTW ECDOs provide stable and reproducible readings right from the start:

- No break-in
- No long-term drift
- No zero point drift due WTW's patented TriOxmatic® principle.



With safety experience

WTW's TriOxmatic® has been thoroughly proven in many years of field use: More than 20,000 installations can be found in reliable operation worldwide.

FDO® and TriOxmatic® in comparison

	FDO® 700 IQ / 701 IQ	TriOxmatic® 700 IQ / 701 IQ / 702 IQ	TriOxmatic® 700 / 690 / 701
Measuring principle	Optical	Electrochemical	Electrochemical
Membrane exchange	Yes – exchange cap – self-recognition of cap via IQMC technology	Yes – exchange of membrane and electrolyte	Yes – exchange of membrane and electrolyte
Calibration	No	Yes – rarely	Yes – rarely
Drift behavior	No	Yes	Yes
Sulfide and ionogenic substances	No influence	Influence	Influence
Measuring range	Up to 20 mg/l	Up to 60 mg/l	Up to 60 mg/l
Self-diagnosis system	No	Yes	Yes
Trace sensor	No	Yes	Yes
Investment costs	Higher	Reduced	Reduced
Calibration data storage	Yes (IQMC technology)	Yes	No
Signal output	Digital	Digital	Analog
Integrated lightning protection	Yes	Yes	Yes

Digital (electrochemical/optical)

FDO® 700 IQ

Optical working D.O. sensor for the measuring and control of oxygen concentration in the biological cleaning process of wastewater plants, no flow required and H₂S insensitive. Digital sensor for connecting to the IQ SENSOR NET.

FDO® 701 IQ

Optical D.O. sensor as FDO® 700 IQ, but with a faster response time.

TriOxmatic® 700 IQ

Universal oxygen sensor for measuring and controlling oxygen input in biological sewage treatment processes in wastewater treatment plants. Membrane, flow rate and response times equivalent to TriOxmatic® 700, however as digital sensor with calibration value memory for connection to IQ SENSOR NET.

TriOxmatic® 701 IQ

O₂ sensor with increased resolution and improved response times. Technical specifications equivalent to TriOxmatic® 701, however as digital sensor with calibration value memory for connection to IQ SENSOR NET.

TriOxmatic® 702 IQ

Providing similar performance data as the TriOxmatic® 701, the 702 IQ model is specifically designed for trace level measurements in the ppb range. This sensor is ideally suited for use in ultra-pure water applications; e.g. monitoring of boiler feed water or drinking water purification. The applied digital technology permits integrated storage of calibration values and simple connection to IQ SENSOR NET.

Analog (electrochemical)

TriOxmatic® 700 / 700 IN

The standard Model TriOxmatic® 700 is a rugged dissolved oxygen sensor with a very durable 50 micron thick hydrophobic membrane, a minimal flow rate of 0.5 cm/sec and a medium response time of less than 180 sec. With these features, this membrane sensor is ideally suited for any D.O. measurement in biological purification stages of municipal waste water treatment plants; e.g. control of the oxygenation. The response of the sensor prevents signal disturbances due to rising air bubbles thus eliminating false readings and improved stability. This is specially important for measurements in aeration tanks.

TriOxmatic® 690

This cost-effective D.O. sensor offers the same specifications and features as the Model TriOxmatic® 700, except it does not have the sensor monitoring function. This unit is primarily designed for conventional D.O. measurements, where a continuous membrane check is not needed; e.g. general applications in water quality analysis.

TriOxmatic® 701

Equipped with a special 25 micron thick membrane, the Model TriOxmatic® 701 features an enhanced resolution and a faster response time. This sensor is ideally suited for low level concentration applications; e.g. measurements of residual oxygen in the denitrification of biological sewerage treatment.

Technical Data digital D.O. Sensors

Type	TriOxmatic® 700 IQ (SW*)	TriOxmatic® 701 IQ	TriOxmatic® 702 IQ	FDO® 700 IQ (SW*)	FDO® 701 IQ (SW*)
Measuring method	Electrochemical	Electrochemical	Electrochemical	Optical	
Measuring range (25 °C)					
O ₂ concentration	0.0 ... 60.0 mg/l	0.00 ... 20.00 mg/l 0.0 ... 60.0 mg/l	0 ... 2000 µg/l 0.00 ... 10.00 mg/l	0 ... 20.00 mg/l (0 ... 20.00 ppm)	
O ₂ saturation	0 ... 600 %	0.0 ... 200.0 % 0 ... 600 %	0 ... 110 %	0 ... 200.0%	
Resolution					
O ₂ concentration	0.1 mg/l	0.01 mg/l 0.1 mg/l	0.001 mg/l 0.01 mg/l	0.01 mg/l (0.01 ppm)	
O ₂ saturation	1 %	0.1 % 1 %	0.1 %	0.1 %	
Response time at 25 °C	t ₉₀ : 180 s	t ₉₀ : 30 s t ₉₉ : 90 s	t ₉₀ : 30 s t ₉₉ : 110 s	t ₉₀ : <150 s t ₉₅ : <200 s	t ₉₀ : <60 s t ₉₅ : <80 s
Minimum flow rate	0.05 m/s	0.23 m/s	0.3 m/s	No drift required	
SensCheck	SensLeck (700 IQ) SensReg (700 IQ/ 700 IQ SW)	SensLeck SensReg	– SensReg	Monitoring of membrane function	
Signal output	Digital	Digital	Digital	Digital	
Sensor memory for calibration values	Yes	Yes	Yes	Yes (factory calibrated)	
Power consumption	0.2 Watt	0.2 Watt	0.2 Watt	0.7 Watt	
Temp. measurement	Integrated NTC, 23 ... 140 °F (-5 °C ... +60 °C)				
Temp. compensation	32 ... 140 °F (0 °C ... +60 °C)			23 ... 122 °F (-5 °C ... +50 °C)	
Maximum pressure	10 bar (incl. sensor connection cable)				
Ambient conditions	Operating temperature: 32 ... 140 °F (0 °C ... +60 °C) Storage temperature: 32 ... 149 °F (0 °C ... +65 °C)			23 ... 122 °F (-5 °C ... +50 °C) -13 ... 122 °F (-25 °C ... +50 °C)	23 ... 104 °F (-5 °C ... +40 °C) -13 ... 104 °F (-25 °C ... +40 °C)
Electrical connections	2-wire shield cable with quick fastener to sensor				
Input power	Powered by IQ SENSOR NET				
Translet voltag protection	Yes				
EMI/RFI Conformance	EN 61326, Class B, FCC Class A; Intended for indispensable operation				
Certifications	CE, cETL, ETL				
Mechanical	Membrane head assembly, locking cap: POM Sensor body: 316 Ti stainless steel Protection rating: IP 68			Sensor cap, fixation: POM, PVC, silicone, PMMA housing shaft: VA steel 1.4571 protection type IP 68	
Dimensions (length x diameter)	14.17 x 1.57 in. (360 x 40 mm); SW: 14.17 x 2.34 in. (360 x 59.5 mm)			15.75 x 1.57 in. (400 x 40 mm) SW: 15.75 x 2.34 in. (400 x 59.5 mm)	
	incl. connection thread of SACIQ sensor connection cable				
Weight (Approx.)	1.46 lb (660 g, without sensor connection cable); SW: 2.58 lb (1,170 g)			1.98 lb (900 g) SW: 3.31 lb (1.5 kg)	
Guaranty	2 years for sensor acc. § 10 AGB				

Ordering Information

Digital D.O. Sensors	Order No.
TriOxmatic® 700 IQ	D.O. sensor for water/wastewater; oxygenation determination 201 640
TriOxmatic® 701 IQ	D.O. sensor for water/wastewater; oxygenation/residual oxygen determination 201 644
TriOxmatic® 702 IQ	D.O. sensor, ppb measuring range; ultrapure water/boiler feedwater 201 646
FDO® 700 IQ	Digital calibration-free optical O ₂ sensor for water/wastewater, determination of oxygen concentration 201 650
FDO® 700 IQ SW	Digital calibration-free optical O ₂ sensor for water/wastewater, determination of oxygen concentration in sea water 201 652
SACIQ-7,0	Sensor connection cable for all IQ sensors, cable length 23 ft. (7.0 m) 480 042



Further cable lengths and special seawater/brackwater designs see brochure "Product Details"

* SW: Sensor in sea water design (with plastic armouring (POM))

Configuration Guide digital D.O. measurement

	1. Measuring range 2. Response time t_{90} 3. SensCheck Function	IQ SENSOR NET Systems 2020 XT / 182
TriOxmatic® 700 IQ D.O. sensor for water/wastewater	1.: 0.0 ... 60.0 mg/l 0 ... 600% 2.: <180 s 3.: SensLeck SensReg	<ul style="list-style-type: none"> • Water/wastewater • Oxygenation • Fishfarming • Water monitoring
TriOxmatic® 701 IQ D.O. sensor for water/wastewater	1.: 0.00 ... 20.00 mg/l 0.0 ... 60.0 mg/l 0.0 ... 200.0% 0 ... 600% 2.: <30 s 3.: SensLeck SensReg	<ul style="list-style-type: none"> • Water/wastewater • Oxygenation • Residual D.O.
TriOxmatic® 702 IQ Trace Level D.O. sensor	1.: 0 ... 2000 µg/l 0.00 ... 10.00 mg/l 0 ... 110% 2.: <30 s 3.: SensReg	<ul style="list-style-type: none"> • ppb measuring range • Ultrapure water • Boiler feedwater
FDO® 700 IQ D.O. sensor for water/wastewater	1.: 0.0 ... 20.0 mg/l 0 ... 200% 2.: <150 s 3.: –	<ul style="list-style-type: none"> • Water/wastewater • Oxygenation • Fishfarming • Water monitoring
FDO® 700 IQ SW D.O. sensor for water/wastewater	1.: 0.0 ... 20.0 mg/l 0 ... 200% 2.: <150 s 3.: –	<ul style="list-style-type: none"> • Water/wastewater • Oxygenation • Seawater • Fishfarming

— Not Applicable

Analog D.O. measurement

Configuration guide of analog D.O. sensors can be seen on **page 99**



Technical Data analog D.O. Sensors

Type	TriOxmatic® 690 / 700 (SW*) / 700 IN	TriOxmatic® 701
Measuring method	Electrochemical	Electrochemical
Measuring range (25 °C)		
O ₂ concentration	0.0 ... 60.0 mg/l	0.00 ... 20.00 mg/l 0.0 ... 60.0 mg/l
O ₂ saturation	0 ... 600%	0.0 ... 200.0% 0 ... 600%
	<i>(depending upon the selected monitor model)</i>	
Resolution		
O ₂ concentration	0.1 mg/l	0.01 mg/l 0.1 mg/l
O ₂ saturation	1%	0.1% 1%
Response time at 25 °C	t ₉₀ : 180 s	t ₉₀ : 30 s t ₉₉ : 90 s
Minimum flow rate	0.05 m/s	0.23 m/s
SensCheck	SensLeck (700 / 700 IN) SensReg (700 / 700 SW)	SensLeck SensReg
Signal output	Analog	Analog
Temp. measurement	Integrated NTC, 23 ... 122 °F (-5 °C ... +50 °C)	
Temp. compensation	32 ... 122 °F (0 °C ... +50 °C)	
Maximum pressure	10 bar	
Ambient conditions	Operating temperature: 32 ... 122 °F (0 °C ... +50 °C) Storage temperature: 32 ... 122 °F (0 °C ... +50 °C)	
Electrical connections	Integrated PU connection cable with fitted 7-pole screw connector (IP65)	
Input power	Powered by WTW D.O. monitor	
Translet voltag protection	Yes	
EMI/RFI Conformance	EN 61326 Class B, FCC Class A	
Certifications	CE	
Mechanical	Membrane head assembly, locking cap: POM Sensor body: 316 Ti stainless steel Protection rating: IP 68	
Dimensions (length x diameter)	7.83 x 1.57 in. (199 x 40 mm) SW: 8.90 x 2.34 in. (226 x 59.5 mm)	
Weight (Approx.)	1.46 lb (660 g); SW: 1.90 lb (860 g)	
Guaranty	2 years for sensor acc. § 10 AGB	

Ordering Information

Analog D.O. Sensors		Order No.
TriOxmatic® 700-7	D.O. sensor for water/wastewater; oxygenation determination; cable length 23 ft. (7.0 m)	201 670
TriOxmatic® 690-7	Same as model 700-7, but without SensCheck function; cable length 23 ft. (7.0 m)	201 690
TriOxmatic® 701-7	D.O. sensor for water/wastewater; oxygenation/residual oxygen determination; cable length 23 ft. (7.0 m)	201 678
TriOxmatic® 700 IN-7	D.O. sensor for highly polluted industrial wastewater; cable length 23 ft. (7.0 m)	201 695

IP 68
2 Year Guaranty
Further cable lengths and special seawater/brackwater designs see brochure "Product Details"
** SW: Sensor in sea water design (with plastic armouring (POM))*



Online pH/ORP Measurement

Measuring · Monitoring · Controlling

pH is one of the most important analysis parameters measured throughout the water, wastewater and many process industries. In the biological treatment of wastewaters, for example, the acidic or alkaline condition of the mixed liquor has an essential influence on the activity of the microorganisms; i.e., continuous online pH control is required. Precise and reliable systems for pH monitoring and control are also necessary in drinking water plants and in a variety of industrial process technologies.

Over the last 50 years, WTW have been designing and manufacturing precision systems for pH measurement. WTW's technical expertise and long experience in this field are the reason that our on-line pH instruments are now recognized for their excellent performance, reliability and product quality.

Online pH/ORP

- Wastewater Treatment Facilities
- Water Treatment Utilities
- Neutralization Plants
- Surface Waters and Groundwater
- Food Industry
- Chemical Production
- Industrial Processes

Neutralization/Precipitation/Detoxification

Both in water and wastewater treatment and also in industrial processes pH is of great practical importance. The acidity or alkalinity of a process medium plays a key role in many chemical or biological reactions as well as in mechanical/physical actions. A number of reactions – in precipitation and detoxification, for example – may only take place if the pH condition is properly controlled. A “misadjusted” pH can cause a variety of serious effects, of which corrosion is the most common. Therefore, at a low or high pH, **neutralization** treatment often is required.



In the area of **municipal and industrial wastewater** treatment extreme pH conditions may result in the following harmful effects:

- Microorganisms in biological purification processes are sensitive to acidic and alkaline conditions. Therefore, the pH of the sewage is supposed to be in the neutral range of pH 7. At pH levels of less than 5 or more than 10 the activity of the bacteria practically ceases.
- pH values of 6.5 and lower result in gradual destruction of metallic materials and mechanical components, and even in damage of the sewer network.
- The solubility of many substances varies with the pH level and temperature. Undesirable and obstructive precipitation of solids may be the result.

Today’s legislative regulations and environmental directives in many countries already require that trade effluents may only be discharged into municipal sewer systems if the pH is between 6.5 and 8.5. For this reason, industrial dischargers, for instance, breweries and dairies, often have to pre-treat its effluent in a **neutralization** plant.

pH Control System

Neutralization, precipitation and detoxification not only require continuous pH measurement but also an efficient pH control system. In less demanding applications, such as stable processes with slowly changing conditions, a simplified 2-point logic control may be adequate. In many cases, however, a proportional control loop is considerably more efficient and also economical with regard to dosing of flocculants or neutralization chemicals.

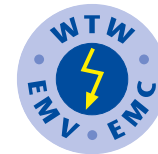

pH measuring technology by WTW

WTW’s complete line of pH/ORP instrumentation comprises sensor assemblies, monitors and system components for a wide range of applications.

In addition to the well proven SensoLyt® sensor assemblies, which are widely used in wastewater facilities, the product line includes ruggedized sensor assemblies for in-line measurements in industrial processes.

The proven monitors of the 170 and 296 series have a PIF control algorithm. A special measuring transducer as well as sensors and accessories are available for use in explosion-proof areas (see brochure “Product Details”).

The IQ SENSOR NET and the IQ sensors open up a whole new realm of technology with features such as an immense degree of flexibility and “sensors which can be pre-calibrated in the laboratory”.

Parameter section

Dissolved Oxygen

pH/ORP

Conductivity

Turbidity/Suspended Solids

Nitrogen

Carbon: COD/TOC/DOC/BOD/SAC

Phosphate

Sludge level

SensoLyt® pH/ORP Sensor Systems

- Sensor check function for glass breakage detection
- Robust mechanical design
- Simple change of pH electrode
- Pre-calibration of sensor possible (SensoLyt® 700 IQ)



SensoLyt® 700



SensoLyt® 700 IQ

SensoLyt® System Design

For continuous pH/ORP measurement, especially under the difficult conditions very often found in sewage treatment facilities, very high demands are made concerning the reliability and operating safety of the systems employed.

Designed specifically for these harsh applications, the SensoLyt® sensors are precision engineered assemblies, which consist of a submersible housing with a built-in preamplifier and the appropriate combination pH or ORP electrode. In combination with our high-performance monitors, the sensors constitute an integrated, extremely reliable pH/ORP measuring system which represents the highest standard, state-of-the-art technology with regard to accuracy, EMC noise immunity and economy.

The digital technology of the IQ sensors, which can store calibration values directly in the sensor, offer particular advantages. This feature allows the user to calibrate the sensor in the laboratory and then return it to its location of use. This provides a certain independency, especially in winter or with bad weather conditions. Its sensor's quick connection permits direct reintegration into the system.



IQ Sensor connection

SensoLyt® Combination Electrodes

- Reliable
- Stable against interference
- Easy to maintain



The reliability of pH and ORP measurements are determined to a large extent by the quality of the pH/ORP electrode which commonly is exposed to extreme conditions; particularly in many industrial applications.

The design of the applied reference system used is crucial to the overall performance of an electrode. In SensoLyt® combination electrodes the reference is a conventional Ag/AgCl/Cl electrode system, completely embedded in a pressure resistant solid gel-polymer electrolyte. As concentration changes in gel-type electrolyte occur very slowly, i.e. the electrochemical characteristic of the cell is unchanged, a stable and constant reference potential will be achieved.

With this electrode design, the polymer matrix/process fluid interphase consists of a pinhole diaphragm; i.e. an electrical flux is established through two fine holes in the cell of the reference system. Such a junction especially reduces the risk of failures.

In addition, SensoLyt® combination electrodes require very little maintenance as there is no electrolyte replacement.



SensoLyt® SEA-HP

SensoLyt® SEA / SE*

This pressure and temperature resistant combination pH electrode incorporates a double pin-hole junction and a gel polymer solid electrolyte, which is AgCl free and therefore resistant to sulfides.

Measuring range: pH 2 ... 12

- Highly contaminated sewage
- Emulsions and suspensions
- Media containing proteins and sulfides

SensoLyt® SEA-HP

Analog SensoLyt® SEA version, with optimized armoring for use under high pressure / temperature conditions.

Measuring range: pH 4 ... 12

- Inline measurement in pipes

SensoLyt® DWA / DW*

Especially its long service life and precise measurement make it stand out from the crowd, in particular for measurements of drinking water with low conductivity.

Measuring range: pH 0 ... 14

- Drinking water

SensoLyt® ECA / EC*

This combination pH electrode has a single pin-hole junction and a gel electrolyte. With its long-term stability it provides an economical solution, particularly in most wastewater facilities.

Measuring range: pH 2 ... 12

- Normally polluted wastewater

SensoLyt® PtA / Pt*

This ORP electrode is also fitted with a pin-hole junction, and is primarily recommended for applications in heavily contaminated wastewater.

Measuring range: ± 2000 mV

- Municipal and industrial sewage
- Emulsions and suspensions
- Media containing proteins and sulfides

* electrode without armor for direct use in flow-thru vessels

Parameter section

Dissolved Oxygen

pH/ORP

Conductivity

Turbidity/Suspended Solids

Nitrogen

Carbon: COD/TOC/DOC/BOD/SAC

Phosphate

Sludge level

SensoLyt® Sensor Assemblies

SensoLyt® sensor assemblies perform multiple functions:

- **preamplification** of the electrode signal
- holder for an integrated NTC sensor for **temperature measurement**
- reliable **protection** of the installed pH electrodes against mechanical damage
- Digital signal processing with calibration value storage (IQ sensors)

The very low voltage signal delivered by the pH/ORP electrode is very susceptible to noise and ground-loop interferences. For this reason WTW has integrated a preamplifier in the sensor assemblies. Its amplification and impedance conversion assure low-impedance and thus reliable signal transmission over long distances; e.g. required for operation with remotely installed monitors.

SensoLyt® sensor assemblies feature a built-in NTC thermistor for temperature measurement and automatic temperature compensation. This enables both pH or ORP and temperature to be measured simultaneously with a single probe. Under the rigorous operating conditions of an industrial plant, e.g. a wastewater treatment plant, the rugged design of the housing provides important mechanical protection of the glass pH electrode. For service purposes, the electrode can be replaced in the field without tools.

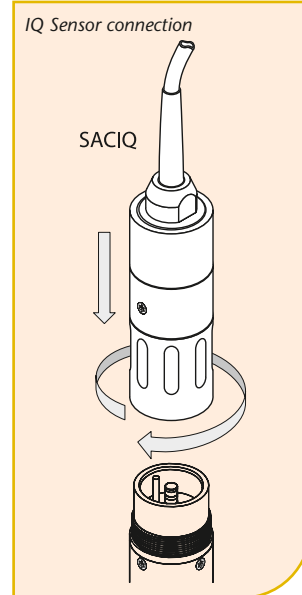
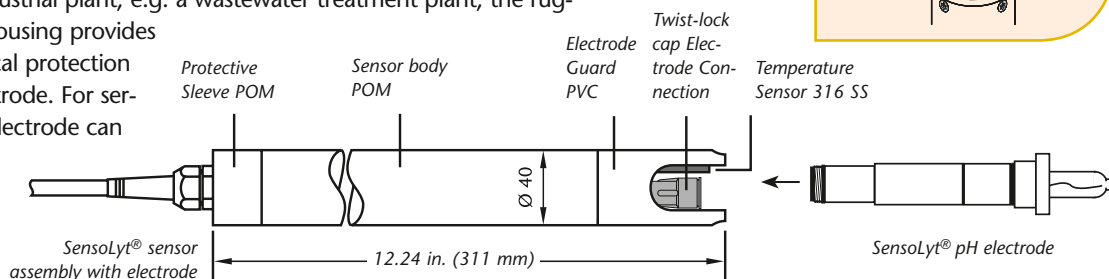

Digital

SensoLyt® 700 IQ

Digital pH/ORP armature with integrated preamplifier and lightning protection as well as digital signal processing and integrated temperature probe for connection to an IQ SENSOR NET. A special circuiting permits glass breakage detection monitoring. Due to the integrated calibration value memory, a "pre-calibrated pH measurement", the value of which is stored in the sensor, can be set in the laboratory. The sensor's quick release coupling allows the user to remove it from the location of use and return it after successful calibration in the laboratory. With an IQ connection in the laboratory, inconvenient field calibration under adverse conditions can be completely eliminated.

Analog

SensoLyt® 700

The SensoLyt® 700 standard assembly incorporates an integrated preamplifier and a built-in stainless steel NTC temperature sensor. When using a WTW monitor, a special circuitry allows the pH electrode to be monitored for glass breakage. In addition, the SensoLyt® 700 offers as a standard feature an efficient lightning protection system. The SensoLyt® 700 sensor assembly can be fitted with any combination electrode of the SensoLyt® series. It is compatible with all WTW monitors of the EcoLine and QuadroLine® Series.

SensoLyt® 690

Same as SensoLyt® 700, but without the SensCheck function.

SensoLyt® 650

The SensoLyt® 650 unit is a passive assembly without preamplifier; i.e., it is designed for "high-impedance operation" with the electrode connected directly to the monitor input. The assembly is directly compatible with the high-impedance input of following WTW monitors: pH 170 and pH 296 or Stratos 2211 X pH models.

Technical Data SensoLyt® digital Sensor Assemblies

Type	SensoLyt® 700 IQ (SW*)
Integrated Preamplifier	Yes
Signal output	Digital
Sensor check funktion	Yes
Sensor memory for calibration values	Yes
Power consumption	0.2 watts
Temperature measurement	Integrated NTC, 23 ... 140 °F (-5 ... +60 °C)
Ambient conditions	Operating temperature: 32 ... 140 °F (0 ... +60 °C)
Electrical connections	2-wire shielded cable with quick fastener to sensor
Transient voltage protection	Yes
EMI/RFI Conformance	EN 61326 class B, FCC Class A Intended for indispensable operation
Certifications	CE, cETLus
Mechanical	Sensor body: 316 Ti stainless steel Protection cap: PVC Sensor holder: POM Protection rating: IP 68
Dimensions (L x D)	20 x 1.57 in. (508 x 40 mm); SW: 20.78 x 2.34 in. (515 x 59.5 mm)
Weight (without cable)	2.14 lb (970 g) SW: approx. 3.97 lb (1.800 g)
Guaranty	2 years for defects of quality

Ordering Information digital pH/ORP Sensors

Digital SensoLyt® Sensors		Order No.
SensoLyt® 700 IQ	pH/ORP sensor for combination electrodes SensoLyt® SEA, DWA, ECA, PTA	109 170
SACIQ-7,0	Sensor connection cable for all IQ sensors, cable length 23 ft. (7.0 m)	480 042



*on armature

Further cable lengths, special design (e.g. for seawater) and buffer solutions see brochure "Product Details"

* SW: Sensor in sea water design (with plastic armouring (POM))

Technical Data analog SensoLyt® Sensor Assemblies

Type	SensoLyt® 700 (SW*)	SensoLyt® 690	SensoLyt® 650
Integrated Preamplifier	Yes	Yes	No
Signal output	Low impedance, analog	Low impedance, analog	High impedance
Sensor check funktion	Yes	No	No
Sensor memory for calibration values	—		
Power consumption	—		
Temperature measurement	Integrated NTC, 32 ... 140 °F (0 ... +60 °C)		
Ambient conditions	Operating temperature: 32 ... 140 °F (0 ... +60 °C)		
Electrical connections	integrated PU connecting cable with fitted 7-pole screw connector (IP 65)		Integral PU connection cable with bare cable ends
Transient voltage protection	Yes		
EMI/RFI Conformance	EN 61326 class B, FCC Class A		
Certifications	CE		
Mechanical	Sensor body: POM Protective cap: PVC Protection rating: IP 68		
Dimensions (L x D)	12.24 x 1.57 in. (311 x 40 mm); SW: 15.52 x 2.34 in. (318 x 59.5 mm)		
Weight (without cable)	Approx. 0.71 lb (320 g); SW: approx. 1.94 lb (880 g)		
Guaranty	2 years for defects of quality		

Technical Data SensoLyt® Combination Electrodes

Type	SEA/SE**	SEA-HP	DWA/DW**	ECA/EC**	PtA/Pt**
Electrode type	Gel-polymer solid electrolyte double pinhole junction		Modified gel electrolyte single pinhole junction	Gel electrolyte single pinhole junction	Gel-polymer solid electrolyte double pinhole junction
Operation conditions (Overpressure/temperature)	10 bar/68 °F (20 °C) 1 bar/140 °F (60 °C)	10 bar/140 °F (60 °C)	6 bar/68 °F (20 °C) 1 bar/140 °F (60 °C)	6 bar/68 °F (20 °C) 1 bar/140 °F (60 °C)	10 bar/68 °F (20 °C) 1 bar/140 °F (60 °C)
	32 ... 140 °F (0 ... 60 °C)	32 ... 140 °F (0 ... 60 °C)	32 ... 140 °F (0 ... 60 °C)	32 ... 140 °F (0 ... 60 °C)	32 ... 140 °F (0 ... 60 °C)
Measuring range	2 ... 12 pH	4 ... 12 pH	0 ... 14 pH	2 ... 12 pH	±2000 mV***
Mechanical	Cylindrical glass membrane, armored version with PVC armouring (SEA-HP: POM), 2 Viton O-ring seals for mounting into SensoLyt® sensor assemblies				
Dimensions	Length 4.72 in./120 mm (without plug head)				
Electrical connections	watertight plug head connector				
Guaranty	6 months for defects of quality				

Ordering Information analog pH/ORP Sensors

Analog SensoLyt® Sensors		Order No.
SensoLyt® 700-7	pH/ORP sensor with integrated preamplifier; cable length 23 ft. (7.0 m)	109 191
SensoLyt® 690-7	Same as model 700-7, but without SensCheck function	109 180
SensoLyt® 650-7	pH/ORP sensor for high impedance operation; cable length 23 ft. (7.0 m) (for SensoLyt® SEA, DWA, ECA, PtA)	109 195
SensoLyt® Combined electrodes		Order No.
SensoLyt® SEA	pH combination electrode, measuring range 2 ... 12 pH, for mounting into SensoLyt® sensor assemblies	109 115
SensoLyt® SEA-HP	pH combination electrode, measuring range 4 ... 12 pH, for mounting into SensoLyt® sensor assemblies	109 118
SensoLyt® DWA	pH combination electrode, measuring range 0 ... 14 pH, for mounting into SensoLyt® sensor assemblies	109 119
SensoLyt® ECA	pH combination electrode, measuring range 2 ... 12 pH, for mounting into SensoLyt® sensor assemblies	109 117
SensoLyt® PtA	ORP combination electrode, measuring range ± 1000 mV, for mounting into SensoLyt® sensor assemblies	109 125
SensoLyt® SE	Same as model SEA, but without armor; e.g. for direct use in flow-thru vessels	109 100
SensoLyt® DW	Same as model DWA, but without armor; e.g. for direct use in flow-thru vessels	109 103
SensoLyt® EC	Same as model ECA, but without armor; e.g. for direct use in flow-thru vessels	109 102
SensoLyt® Pt	Same as model PtA, but without armor; e.g. for direct use in flow-thru vessels	105 412



*on armature

Further cable lengths, special design (e.g. for seawater) and buffer solutions see brochure "Product Details"

* SW: Sensor in sea water design (with plastic armouring (POM))

** Electrode without armor, e.g. for direct use in flow-thru vessels

*** Depending on monitor

CHEMtrac Valve Assemblies

For many years CHEMtrac valve assemblies have been successfully used for in-line pH and ORP measurement in industrial process applications. The devices are designed for installation in pipes or vessels, and permit manual insertion and retraction of the pH sensor without interrupting the process flow. CHEMtrac assemblies offer an enhanced reliability and safety for use under tough process conditions; e.g., measurement in pressure vessels.

CHEMtrac 830M

- Safe operation with overpressure
- Easy and fast handling
- Up to 16 bar and 140° C operatable

The **CHEMtrac 830M** is a high-performance valve assembly which meets the increasingly stringent requirements of industrial practice. In particular, the device satisfies the high safety criteria currently set for process equipment by using a state of the art technology. In combination with WTW monitors the CHEMtrac sensor valve assembly provides versatile and integrated pH measurement systems for a variety of industrial applications.

CHEMtrac 830M is dedicated for

- Mounting in pipelines and pressure vessels
- Complete separation of measuring media to environment
- Compression-proof electrode with polymer electrode

The manually operated **CHEMtrac valve assembly** is available in a robust stainless steel construction, all wetted parts are made of stainless steel 1.4404/316 L. Thus, the valve assembly is operable at pressures of up to 16 bar and at temperatures of up to 291.2 °F (140 °C).



- Parameter section
- Dissolved Oxygen
- pH/ORP**
- Conductivity
- Turbidity/Suspended Solids
- Nitrogen
- Carbon: COD/TOC/DOC/BOD/SAC
- Phosphate
- Sludge level

ProcessLine Combination pH Electrode

The CHEMtrac 830 M valve assembly is fitted with ProcessLine combination pH electrodes.

The special construction of the ProcessLine electrodes brings them very close to the optimum for liquid electrolyte electrodes with respect to their accuracy, stability, rapid response and long working life:

- Low maintenance, i.e. no electrolyte topping up or installation of complicated pressure sequence controls.
- Pinhole junction, so reference electrode is not polluted or blocked.
- Duralide electrolytes with high KCl content and special properties stand for very long working life combined with rapid and stable measured values.
- Proven H membrane glass with very low alkali errors and optimized spherical shape.
- Extended applications in media with extreme ionic strengths, strongly oxidizing properties, high base or acid content or even solvents.

This is why ProcessLine electrodes require very little maintenance and offer great potential savings, which makes them the first choice for the hardest process applications, particularly such as those found in the chemical industry.

System compatibility

The pH combination electrodes are connected directly to the high-impedance input of the model pH 170 and pH 296 as well as IQ SENSOR NET monitors with the suitable connection cable. If there is a long distance between the measuring point and the monitor then the KI/pH 170 terminal box e.g. KI/pH-MIQ/S must be included. This ensures low-impedance interference-free signal transmission to the monitor (not in combination with InPro 4250). The terminal box also allows the connection of a temperature sensor if automatic temperature compensation is required.



Technical Data ProcessLine pH/ORP Electrodes

	PL 80-225pH	PL 81-225pHT VP	PL 82-225pHT VP	PL 89-225Pt
Operating conditions pH	pH 0 ... 14	pH 0 ... 14	pH 0 ... 14	pH 0 ... 14
Temperature range	0 °C ... 130 °C	0 °C ... 130 °C	0 °C ... 130 °C	0 °C ... 130 °C
Reference system	DuraLid polymer electrolyte, low maintenance, Ag/AgCl system			
Max. Pressure	12 bar (total temperature range)			
Junction	double pinhole			
Diameter	0.47" (12 mm)			
Length	8.86" (225 mm)			
Temperature sensor	–	Pt 1000	Pt 100	–
Connection	S7 plug head, PG 13.5	VP plug	VP plug	S7 plug head, PG 13.5
Guaranty	6 months for defects of quality			

Technical Data CHEMtrac 830 M Sensor Valve Assembly

Description	Manually operated valve assembly, stainless steel (1.4404/316L), for all kind of Ø0.47"/8.86" (Ø12/225 mm) sensors with PG13.5 thread
Immersion length	up to 4.21" (107 mm)
Operating conditions:	12 bar, 140 °C
Flushing chamber connection	G 1/8"
Guaranty	1 year for defects of quality

Ordering Information

InTrac® Sensor Valve Assembly		Order No.
CHEMtrac 830 M	Manually operated valve assembly, stainless steel (1.4404/316L) for installation/changing/maintenance of pH/ORP electrodes without process interruption	109 237
Combination pH/ORP electrodes		Order No.
PL 80-225pH	Combination pH electrode for CHEMtrac 830 M, S7 plug	109 234
PL 81-225pHT VP	Combination pH electrode for CHEMtrac 830 M, VP plug, Pt 1000	109 236
PL 82-225pHT VP	Combination pH electrode for CHEMtrac 830 M, VP plug, Pt 100	109 239
PL 89-225Pt	Combination ORP electrode for CHEMtrac 830 M, S7 plug	109 235

Connecting cables and accessories see brochure "Product Details"



Online Conductivity Measurement

Measuring · Monitoring · Controlling

Conductivity is a well recognized, and sometimes indispensable, parameter of state-of-the-art water, wastewater and industrial process analysis. Continuous measuring systems are employed to monitor the salt load at the influent of wastewater treatment plants, to control quality of drinking water and ultra-pure water or to determine non-specific contaminants in industrial processes.

On-line Conductivity Measurements

- Municipal and Industrial Wastewater
- Water Treatment
- Surface Waters
- Sea Water, Brackish Water, Fishfarming
- Boiler Feed Water
- Demineralization
- Industrial Process Media

For more than 60 years, WTW has been one of the leading manufacturers of precision conductivity measurement systems, setting new standards with innovative sensor technology and fully evolved designs tailored to practical applications. WTW products meet the most stringent requirements set by industry for continuous on-line analysis instruments.

A special measuring transducer as well as sensors and accessories are available for use in explosion-proof areas (see brochure "Product Details").

Conductivity

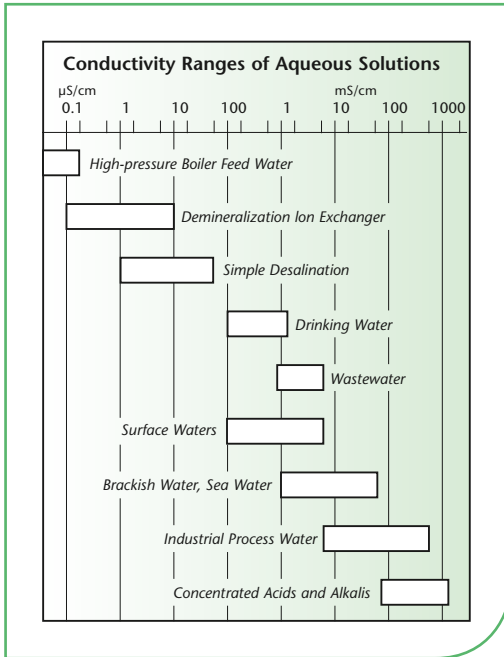

Conductivity as a summation parameter is a measure of the level of ion concentration of a solution. The more salts, acids or bases are dissociated, the greater the conductivity of the solution. In water or wastewater it is mainly a matter of the ions of dissolved salts, and consequently the conductivity is an index of the salt load in wastewater or, respectively, the purity of potable water. The measurement of conductivity is also widely used in industrial production, such as process control in food and pharmaceutical industries.

The measurement of conductivity is generally expressed in S/cm (or mS/cm) which is the product of the conductance of the test solution and the geometric factor of the measuring cell. The scale for aqueous solutions starts at a conductivity of $0.05 \mu\text{S}/\text{cm}$ (at $77^\circ\text{F}/25^\circ\text{C}$) for ultrapure water. The conductivity of natural waters, such as drinking water or surface water is typically in range of $100 - 1000 \mu\text{S}/\text{cm}$. The upper End of the scale is reached by some acids and alkalis.

Temperature Compensation

The conductivity of a solution is critically dependent on temperature. Therefore, the conductivity readings must be referred to a common reference temperature ($77^\circ\text{F}/25^\circ\text{C}$) for comparability. The term "temperature compensation" is used in the sense of a mathematical conversion; i.e. a measured conductivity $\mathcal{K}(\vartheta)$ at any given temperature to the corresponding conductivity value that would be taken at the reference temperature $\mathcal{K}(77^\circ\text{F}/25^\circ\text{C})$.

The conductivity of most aqueous solutions varies more or less linearly with temperature ϑ . In these cases, a linear correction function to compensate for the influence of temperature can be used. For example, the correction coefficient for sewage is approx. $2\%/K$.

WTW monitors automatically calculate the corrected conductivity values based on the selected temperature coefficient. For the compensation of natural water a non-linear function (nLF) (i.e., built-in table for natural water properties) is available.

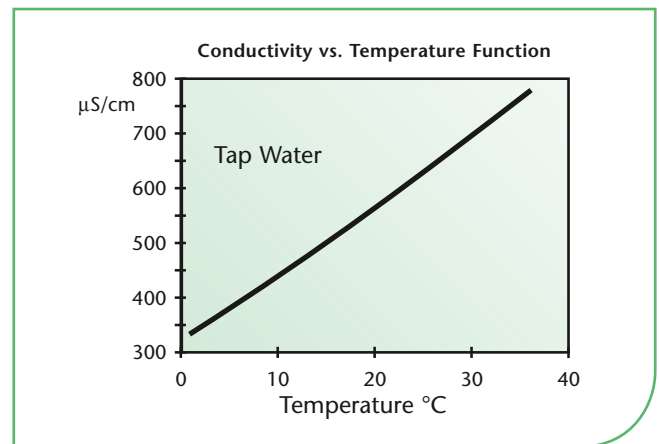

TetraCon® Conductivity Cells

TetraCon® 700/700 IQ

- 4-electrode Design
- Extremely robust and durable
- Large measuring range with only a single cell
- Highly resistant to fouling



TetraCon® 700 IQ

Compared to the 2-electrode sensors, the TetraCon® 4-electrode measuring procedure offers considerable application targeted advantages, especially in the area of higher conductivities.

TetraCon® 700 conductivity sensors are especially suitable for use in wastewater treatment plants dealing with highly loaded sewage. Due to the special measuring technique employed, severe influences from polarization effects are eliminated, resulting in improved accuracy of the sensor. Provided the devices are installed in accordance with the manufacturer's instructions, errors due to the distortion of the current and voltage fields are also avoided.

The special cell geometry of the TetraCon® 700 makes it impervious to fouling, and the abrasion resistant carbon electrodes are also easy to clean. The modern epoxy resin encapsulation technique used diminishes the likelihood of sensor breakage in harsh industrial environments.

The TetraCon® 700 as digital model TetraCon® 700 IQ is also available for connection to IQ SENSOR NET. This version is specially featured by a larger measuring range (10 μ S/cm ... 500 mS/cm).

Furthermore, TetraCon® 700 SW seawater model for fish-farming has proven quality for harsh weather conditions, in salt water and with wave action.

TetraCon® 4-electrode Design

The conductivity of a given electrolyte is determined by an electro-chemical resistance measurement. In its simplest configuration, the measuring cell uses two electrodes to which an alternating voltage is applied. The electric current which is directly proportional to the free ions in the electrolyte is measured. The electronic instrument then calculates the conductivity of the solution, taking into account the absolute cell constant of the sensor.

With the TetraCon® 4-electrode design, two separate electrode pairs are used whereby the currentless voltage electrodes produce a stable and constant reference potential. The voltage drop at the current electrodes is regulated via a potentiostat circuit.

The advantage of this technique is that it eliminates measurement errors usually caused by polarization effects which most likely build up at higher conductivity levels. Contact resistance problems caused by contaminated electrodes is also largely avoided by this design.

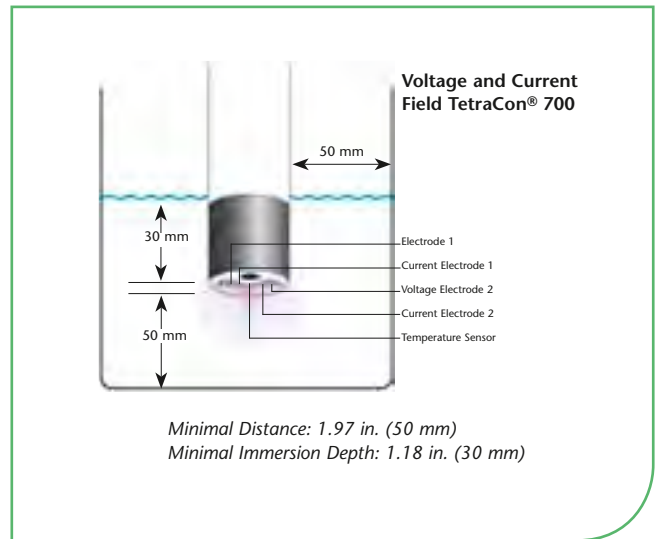

WTW Conductivity Sensors

TetraCon® 700

Rugged conductivity sensor (4-electrode design), with integrated dual thermistor, abrasion resistant carbon electrodes and break-proof epoxy body; measuring range 10 $\mu\text{S}/\text{cm}$ to 1000 mS/cm .

Submersible sensor assembly specially designed for use in wastewater treatment plants.

TetraCon® 325

4-electrode conductivity cell with graphite electrodes, integral temperature probe; measuring range 1 $\mu\text{S}/\text{cm}$ - 2000 mS/cm . Suitable for universal applications.

TetraCon® DU/T

4-electrode conductivity cell with integral flow-thru chamber (7 ml volume), built-in temperature sensor; measuring range 1 $\mu\text{S}/\text{cm}$ to 2000 mS/cm . Recommended for standard industrial applications.

TetraCon® 700 IQ

Digital 4-electrode conductivity cell (same as TetraCon® 700). In addition to the general preferences of IQ technology the TetraCon® 700 IQ offers the benefit of a larger measuring range (10 $\mu\text{S}/\text{cm}$... 500 mS/cm).



LRD 01

316 Ti stainless steel conductivity cell for installation in pipes. Built-in temperature sensor (266 °F/130 °C max.), measuring range 0.01 to 200 $\mu\text{S}/\text{cm}$, pressure resistant up to 14 bar, 1/2 inch NPT thread.

LRD 325

Conductivity measuring cell for installation in pipes. With built-in temperature sensor (up to 212 °F/100 °C). Measuring range 1 $\mu\text{S}/\text{cm}$ to 2 S/cm , pressure resistant up to 10 bar. 1/2 inch NPT thread.

LR 325/01

Low-level conductivity cell with flow-thru chamber, integrated temperature sensor; measuring range 0.001 to 300 $\mu\text{S}/\text{cm}$. For use in ultra-pure water applications; e.g., boiler feed water.

LR 325/001

Like Model LRD 325/01, but with higher resolution; measuring range 0.0001 to 30 $\mu\text{S}/\text{cm}$. Sensor is especially designed for trace measurement in both aqueous and non-aqueous or partially aqueous media.

Technical Data Conductivity Cells

Model	Digital	Analog		
	TetraCon® 700 IQ (SW**)	TetraCon® 700 (SW**)	LRD 01	LRD 325
Sensor Type	4-electrode cell	4-electrode cell	2-electrode cell	4-electrode cell
Measuring Range	10 µS/cm - 500 mS/cm SAL: 0 ... 70 TDS: 0 ... 2000 mg/l	10 µS/cm ... 1000 mS/cm * SAL: 0 ... 70	0.001 ... 200 µS/cm	1 µS/cm ... 2 S/cm
Cell Constants	K=0.917 cm ⁻¹ , ±1.5% (in free solution) K=0.933 cm ⁻¹ , with EBST 700- DU/N flow-thru adapter	K=0.917 cm ⁻¹ , ±1.5% (in free solution) K=0.933 cm ⁻¹ , with EBST 700- DU/N flow-thru adapter	0.1 cm ⁻¹ , ±2%	0.475 cm ⁻¹ , ±1.5%
Signal Output	Digital	Analog	Analog	Analog
Power Consumption	0.2 Watt	—	—	—
Temperature Sensor	Integrated NTC	Integrated NTC	Integrated NTC	Integrated NTC
Temp. Measuring	23 ... 140 °F (-5 ... +60 °C)	32 ... 122 °F (0 ... +50 °C), ±0.2 K	32 ... 266 °F (0 ... +130 °C), ±0.2 K	32 ... 212 °F (0 ... +100 °C), ±0.2 K
Maximum Pressure	10 bar	10 bar (at 68 °F/20 °C)	14 bar (at 68 °F/20 °C)	10 bar (at 68 °F/20 °C)
Electrical Connections	2-wire shielded cable with quick fastener to sensor	Integrated PU connection cable with fitted 7-pole screw connector (IP 65)		
Certifications	CE, cETL, ETL	CE		
Mechanical	Sensor head: PVC Body: 316 Ti stainless steel Protection rating IP 68	Sensor head: PVC Body: 316 Ti stainless steel Protection rating: IP 68	Cell body: 316 Ti stainless steel Threaded 1/2 inch NPT Isolator material: PEEK Protection rating/Electrode: IP 68	Measuring cell: Epoxy / Graphit Thread: 316 Ti stainless steel Protection rating/Electrode head: IP 68
Dimensions (length x diameter)	14.06 x 1.57 in. (357 x 40 mm, incl. connection thread of SACIQ sensor connection cable) SW: 14.06 x 2.34 in. (357 x 59,5 mm)	7.72 x 1.57 in. (196 x 40 mm) SW: 8.78 x 2.34 in. (223 x 59,5 mm)	5.24 x 0.98 in. (133 x 25 mm)	5.24 x 0.98 in. (133 x 25 mm)
Weight (without cable)	Approx. 1.46 lb (660 g) SW: approx. 2.58 lb (1.170 g)	Ca. 660 g; SW: ca. 860 g	Approx. 0.77 lb (350 g)	Approx. 0.66 lb (300 g)
Guaranty	2 years for defects of quality	2 years for defects of quality	2 years for defects of quality	2 years for defects of quality

Technical Data Conductivity Cells for Special Purposes

Model	TetraCon® 325	TetraCon® DU/T	LR 325/01	LR 325/001
Sensor Type	4-electrode cell	4-electrode cell	2-electrode cell	2-electrode cell
Electrode	Carbon	Carbon	316 Ti stainless steel	316 Ti stainless steel
Measuring Range	1 µS/cm ... 2 S/cm	1 µS/cm ... 2 S/cm	0.001 µS/cm ... 200 µS/cm	0.0001 µS/cm ... 30 µS/cm
Cell Constant	K=0.475 cm ⁻¹	K=0.778 cm ⁻¹	K=0.1 cm ⁻¹	K=0.01 cm ⁻¹
Temperature Sensor	Integrated	Integrated	Integrated	Integrated
Flow-thru Measurement	Yes, with additional flow chamber D 201	yes	Yes, with additional flow chamber D01/T	Yes, with integrated flow chamber
Length / Diameter	4.72 in. (120 mm)/ 0.62 in. (15.7 mm)	6.10 in. (155 mm)/ 0.39 in. (10 mm)	4.72 in. (120 mm)/ 0.47 in. (12 mm)	4.72 in. (120 mm)/ 0.79 in. (20 mm)
Guaranty	2 years for defects of quality	2 years for defects of quality	2 years for defects of quality	2 years for defects of quality

Ordering Information

Digital Conductivity Cells		Order No.
TetraCon® 700 IQ	Submersible conductivity sensor for water/wastewater	302 500
SACIQ-7,0	Sensor connection cable for all IQ sensors, cable length 23 ft. (7.0 m)	480 042
Analog Conductivity Cells		Order No.
TetraCon® 700-7	Submersible conductivity sensor for water/wastewater, cable length 23 ft. (7.0 m)	302 316
LRD 01-7	Submersible conductivity sensor for boiler feed water/ion exchanger, cable length 23 ft. (7.0 m)	302 222
LRD 325-7	Submersible conductivity sensor for water/wastewater, cable length 23 ft. (7.0 m)	302 229

Digital:



2 Year
Guaranty

Further cable length and special seawater/brackwater designs and accessories see brochure "Product Details"

Analog:



2 Year
Guaranty

* useable with monitor 170/296: up to 200 mS/cm
** SW: Sensor in sea water design (with plastic armouring (POM))

Configuration Guide digital conductivity measurement			
		1. Measuring range 2. Cell constant 3. Probe type 4. Temperature compensation	5. Temperature range 6. Pressure range 7. Protection rating
			IQ SENSOR NET Systems 2020 XT/182
Digital	TetraCon® 700 IQ	1.: 10 µS/cm ... 500 mS/cm 2.: K=0.917 cm ⁻¹ 3.: 4-electrode cell 4.: NTC	5.: 32 ... 140 °F (0 ... 60 °C) 6.: 10 bar 7.: IP 68 (electrode)
			Water/Wastewater; Usable Measuring Range: 0.00 ... 20.00 µS/cm 0.0 ... 200.0 µS/cm 0.000 ... 2.000 mS/cm 0.00 ... 20.00 mS/cm 0.0 ... 200.0 mS/cm 0 ... 500 mS/cm
Analog			Junction box for connecting the analog measuring cells to the IQ SENSOR NET:
	TetraCon® 700	1.: 10 µS/cm ... 1000 mS/cm 2.: K=0.917 cm ⁻¹ 3.: 4-electrode cell 4.: NTC	5.: 32 ... 122 °F (0 ... 50 °C) 6.: 10 bar 7.: IP 68 (electrode)
	LRD 01	1.: 0,01 ... 200 µS/cm 2.: K=0.1 cm ⁻¹ 3.: 2-electrode cell 4.: NTC	5.: 32 ... 266 °F (0 ... 130 °C) 6.: 14 bar (68 °F/20 °C) 7.: IP 68 (electrode)
	LRD 325	1.: 1 µS/cm ... 2 S/cm 2.: K=0.475 cm ⁻¹ 3.: 4-electrode cell 4.: NTC	5.: 32 ... 212 °F (0 ... 100 °C) 6.: 10 bar 7.: IP 68 (electrode)
	LR 325/01	1.: 0.001 ... 300 µS/cm 2.: K=0.1 cm ⁻¹ 3.: 2-electrode cell 4.: NTC	5.: 32 ... 212 °F (0 ... 100 °C) 6.: 2 bar 7.: IP 68 (electrode)
	LR 325/001	1.: 0.0001 ... 30 µS/cm 2.: K=0.01 cm ⁻¹ 3.: 2-electrode cell 4.: NTC	5.: 32 ... 212 °F (0 ... 100 °C) 6.: 2 bar 7.: IP 68 (electrode)
	TetraCon® 325	1.: 1 µS/cm ... 2 S/cm 2.: K=0.475 cm ⁻¹ 3.: 4-electrode cell 4.: NTC	5.: 32 ... 212 °F (0 ... 100 °C) 6.: 2 bar 7.: IP 68 (electrode)
	TetraCon® DU/T	1.: 1 µS/cm ... 2 S/cm 2.: K=0.778 cm ⁻¹ 3.: 4-electrode cell 4.: NTC	5.: 32 ... 140 °F (0 ... 60 °C) 6.: 2 bar 7.: IP 65
			KI/LF-0,9/MIQ 505 570 KI/LF-0,1 MIQ 505 573 + ADA/AMPH-LAB-LF 303 212 KI/LF-0,4/MIQ 505 572 KI/LF-0,1 MIQ 505 574 + ADA/AMPH-LAB-LF 303 212 KI/LF-0,4/MIQ 505 572 + ADA/AMPH-LAB-LF 303 212 KI/LF-0,7/MIQ 505 571 + ADA/AMPH-LAB-LF 303 212 + KKDU 325 301 963

— Not Applicable

Analog conductivity measurement

Configuration guide of analog conductivity measuring cells can be seen on **page 100**



Turbidity and Suspended Solids

Turbidity

Smell, taste and turbidity are the most important indicators for the quality of potable water.

At the effluent of a waste water treatment plant, turbidity is a quantitative measure of remaining undissolved solids, indicating malfunctions within the treatment process. Turbidity can be measured relatively simple on-line with optical methods. Therefore, turbidity is extremely suitable for measuring the cleaning efficiency of wastewater treatment plants.

Turbidity is typically determined using 90 degree scattered light principle in compliance with EN ISO 7027.

Measuring principle

By the passing of optical radiation through a dispersing system, dispersed solids reduce radiation power by transforming it into another form of energy. This effect is called absorption. The ratio of penetrating to emitting light beams is measured as turbidity.

Factory calibration

The online-sensors from WTW are precisely factory calibrated with a "multi-point" calibration. The calibration is very stable – so further calibration is not needed. Formazine is used as a calibration standard – it is diluted to the necessary concentrations.

Turbidity and Suspended Solids

- Effluent measurement of sewage treatment plants
- Sludge concentration
- Monitoring/controlling of sludge cycle
- Drinking water



Optical unit with ultrasonic cleaning system

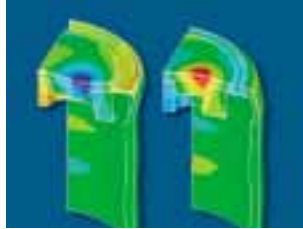

Maximum amplitude at the optical windows

Cleaning system

A number of parameters can have a large impact on the measured value and are automatically compensated. An effective compensation takes into account the influence of a secondary light source, the coloration of particles and the medium. The fouling of the optical path requires an effective cleaning system realised by WTW using a unique Ultrasonic System.

This ultrasonic module, integrated in the VisoTurb® 700 IQ and in the ViSolid® 700 IQ, causes a permanent oscillation on the optical windows avoiding biological fouling.

Pictures show the same sensor with ultrasonic cleaning system switched-off and switched-on in a typical waste water application.

The sensor with switched-off cleaning system (left picture) is completely covered with a biological layer. The sensor with working ultrasonic cleaning system (right) shows no adverse effect.

Suspended Solids

A continuous gravimetric analysis is not possible in waste water treatment process – therefore indirect methods like turbidity measurement are used. The concentration of suspended solids is a very important process parameter for today's sludge treatment. Total suspended solids can be determined online using scattered light or light absorbance. Under normal conditions there is a good correlation to gravimetric analysis.

For the most important sludge characteristics, WTW has defined so called matrix types – with this stored data, even without customer specific calibration a good correlation to total suspended solids concentrations can be achieved.

However, sludges can be totally different – concerning coloration, particle size and structure. Therefore of course a “multi-point” user calibration is possible. This can be done also with the mandatory required gravimetric determination of total suspended solids.

Without ultrasound cleaning system



With ultrasound cleaning system



Application on waste water treatment plants

In order to get a sufficient degree of nitrification, a certain sludge age should not be exceeded. This is significantly influenced by the flow of the surplus sludge and the concentration of TSS in the biological tank measured by the suspended solids sensor. Also the denitrification (N-elimination) and partially the biological P-elimination can be improved by a higher amount of TSS.

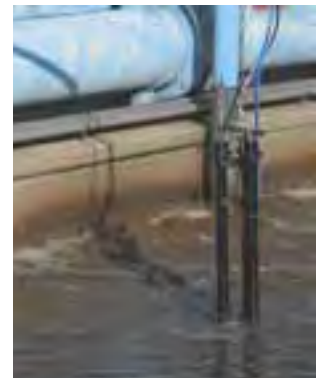

Parameter section

Dissolved Oxygen

pH/ORP

Conductivity

Turbidity/Suspended Solids

Nitrogen

Carbon: COD/TOC/DOC/BOD/SAC

Phosphate

Sludge level

General Features of Sensors

On-line Turbidity and Suspended Solids Measurement using revolutionary technology

Continuous turbidity and suspended solids measurement are of great importance in analytic measurement in modern wastewater treatment plants. Optical infrared scattered light sensors are established for online measurement of this measuring parameter in treatment plants.



A clean sensor – prerequisite for reliable measurements

In optical systems, contamination falsifies readings of turbidity or suspended solids by an indeterminate amount. Once contamination of the optical system has begun, further build-up of particles progresses at an accelerated rate. Especially under the extreme conditions that prevail in wastewater treatment plants, the accumulation of microorganisms represents a genuine problem for the otherwise reliable optical measurement method. Therefore, additional manual cleaning is usually indispensable – despite conventional methods of compensation or cleaning using available wiper systems.

Revolutionary Technology

- Non-mechanical ultrasound cleaning
- Low Maintenance
- Factory Calibrated
- Long-term stability (SensorCheck function)

VisoTurb® and ViSolid® – new sensors for turbidity and suspended solids measurement

With the VisoTurb® 700 IQ and ViSolid® 700 IQ sensors, WTW presents a family of optical sensors for turbidity and suspended solids measurement. These sensors incorporate an ultrasound cleaning system that guarantees low maintenance and long-term reliability of the sensors. Turbidity measurements in aqueous media with VisoTurb® are carried out nephelometrically in compliance with EN ISO 7027. Solid matter measurement with ViSolid® is performed according to the principle of scattered light measurement.

Because of the enormously wide measuring ranges of VisoTurb® (0 – 4000 FNU) and ViSolid® (0 – 300 g/l SiO₂), the best resolution for each measured value can be selected using an AutoRange function. Thus, only two sensors are required to cover almost all applications ranging from drinking water to highly concentrated sludge.

Integrated, wear-free automatic cleaning system

The ultrasound source integrated in the sensor generates high-frequency vibrations of the optical windows in the micrometer range. The maximum vibration amplitudes are at the center of the measurement windows, so that the largest displacement can be found at this location. This prevents accumulation of any kind of contamination from the very start, and thus provides for reliable measurements for continuous operation.

Robust, scratch-proof sapphire measuring window

The sapphire measuring windows are particularly scratch-proof and guarantee accurate measuring results even with permanent use under rough ambient conditions.

Sensor without and with ultrasound cleaning system after 30 days



Extremely low maintenance

- In contrast to traditional sensors equipped with wipers and jutting corners, the exceptionally smooth sensor surface provides a minimum of surfaces on which deposits may accumulate.
- The continuously active ultrasound system inhibits the deposit of all kinds of contamination from the start.
- Thus, the sensor can be operated in a wide variety of applications over several weeks without maintenance.
- Thanks to their robust design and the efficient ultrasound cleaning system, **VisoTurb® 700 IQ** and **ViSolid® 700 IQ** are particularly suitable for applications with extreme conditions, e.g. wastewater treatment plants. They provide the user with a very high degree of measurement accuracy at an exceptionally low maintenance rate.

Turbidity Sensor VisoTurb®

Turbidity Measurement according to the Nephelometric Principle

Using this principle, scattered light is measured at an angle of 90 degree. This method is ideal for low and medium range turbidity up to 4000 FNU. In compliance with EN 27027 and ISO 7027, infra red light with a wavelength of 860 nm is used. This wavelength is outside of the visible range – thus potential coloration of the sample does not effect the measurements.

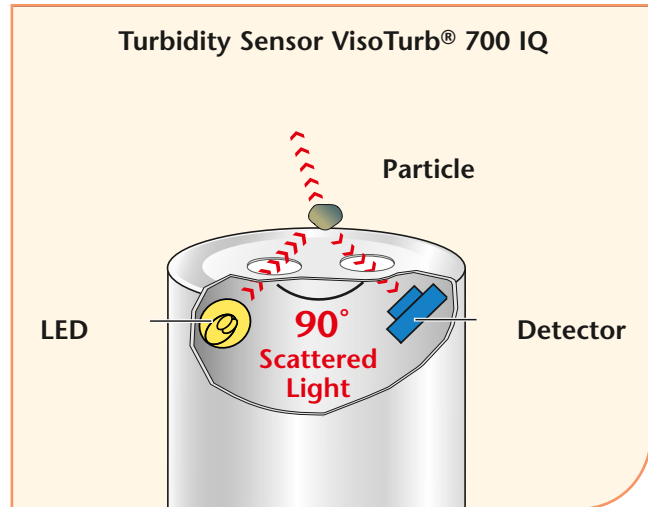

Technical Data VisoTurb® 700 IQ (SW*)

Parameter	FNU; NTU; TEF	mg/l SiO ₂ ; ppm SiO ₂	g/l TSS
Measuring Range	0.05 ... 4000 FNU	0.1 ... 4000 mg/l SiO ₂	0.0001 ... 400 g/l TSS
Typical Applications	Drinking water, surface water, waste water plant: effluent, aeration basin ≤3 g/l TSS		
Calibration	Factory calibration with formazine	Factory calibration with SiO ₂	Calibration by user, (TSS regulations in compliance with DIN 38414)
Process variation coefficient according to DIN 38402 part 51	<1% (in the range up to 2000 FNU)		
Repeatability according to DIN ISO 5725 or DIN 1319	<0,015% or ≥0,006 FNU		
Resolution	Automatic according to measuring range 0.001 ... 1 FNU	0.001 mg/l ... 1 mg/l	0.001 mg/l ... 1 g/l
Cleaning System	Ultrasound cleaning system		
SensCheck	Contamination detection of optical window; failure of cleaning system		
Ambient Conditions	Operating temperature: 32 ... 140 °F (0 ... 60 °C); ultrasonic cleaning system: 32 ... 104 °F (0 ... 40 °C) (overheating protection) Storage temperature: 23 ... 149 °F (-5 ... +65 °C)		
Mechanical Components	Measurement window: Sapphire Sensor body: V4A stainless steel 1.4571 Protection rating: IP 68		
Pressure Resistance	Maximum 10 bar (incl. sensor connection cable)		
Power Consumption	1.5 Watt		
Dimensions	14.37 x 1.57 in. (365 x 40 mm, length x diameter), incl. sensor connection cable SACIQ		
Weight	Approx. 2.18 lb (990 g, without cable)		
Guaranty	2 years for defects of quality		

Ordering Information

		Order No.
VisoTurb® 700 IQ	Turbidity sensor for water/wastewater with ultrasound cleaning system	600 010
SACIQ-7,0	Sensor connection cable for all IQ sensors, cable length 23 ft. (7.0 m)	480 042



Further cable length and special seawater/brackwater designs and accessories see brochure "Product Details"

* SW: Sensor in sea water design (with plastic armouring (POM))

Suspended Solids Sensor ViSolid®

Measuring Principle of Suspended Solids

With increasing concentration of suspended solids, particles will interfere with each other. With this increasing number, not every particle is reached by the light source or the reflected light is not detected by the receiving device – thus incorrect values are measured. So the 90 degree scattered light method used for the turbidity measurement can only be used for lower concentrations.

For this reason WTW uses two methods of measurement – depending on the concentration. For lower concentrations, a scattered light method is used, in case of higher concentrations, the backscatter method is the better choice.

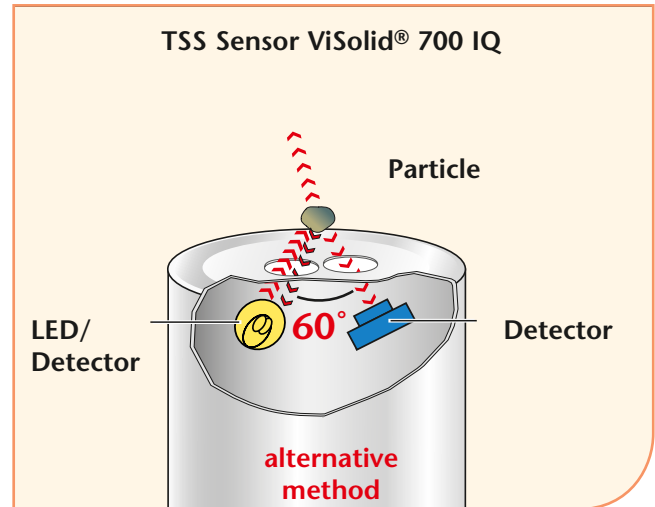

Technical Data ViSolid® 700 IQ (SW*)

Parameter	g/l SiO ₂ / % SiO ₂	g/l TSS / % TSS
Measuring Range	0.01 ... 300 g/l 0.001 ... 30% SiO ₂	0.003 ... 1000 g/l TSS 0.0003 ... 100% TSS
Typical Applications	Matrix type 1: aeration basin of waste water plants even with >3 g/l TSS; return-sludge Matrix type 2: digested sludge	
Calibration	Typical sludge characteristics stored: matrix type 1, matrix type 2 Calibration by user: adjustment via correction factor, 1-point or multi-point calibration possible	
Process variation coefficient according to DIN 38402 part 51	<2% for matrix type 1, <4% for matrix type 2	
Resolution	Automatic according to measuring range 0.1 mg/l ... 0.1 g/l	0.1 mg/l ... 1 g/l
Cleaning System	Ultrasound cleaning system	
SensCheck	Contamination detection of optical window; failure of cleaning system	
Ambient Conditions	Operating temperature: 32 ... 140 °F (0 ... 60 °C) Storage temperature: 23 ... 149 °F (-5 ... +65 °C)	
Mechanical Components	Measuring window: Sapphire Sensor body: V4A stainless steel 1.4571 Protection rating: IP 68	
Pressure Resistance	Maximum 10 bar (incl. sensor connection cable)	
Power Consumption	1.5 Watt	
Dimensions	14.37 x 1.57 in. (365 x 40 mm, length x diameter), incl. sensor connection cable SACIQ	
Weight	Approx. 2.18 lb (990 g, without cable)	
Guaranty	2 years for defects of quality	

Ordering Information

		Order No.
ViSolid® 700 IQ	Suspended solids sensor for water/wastewater with ultrasound cleaning system	600 012
SACIQ-7,0	Sensor connection cable for all IQ sensors, cable length 23 ft. (7.0 m)	480 042



Further cable length and special seawater/brackwater designs and accessories see brochure "Product Details"

* SW: Sensor in sea water design (with plastic armouring (POM))

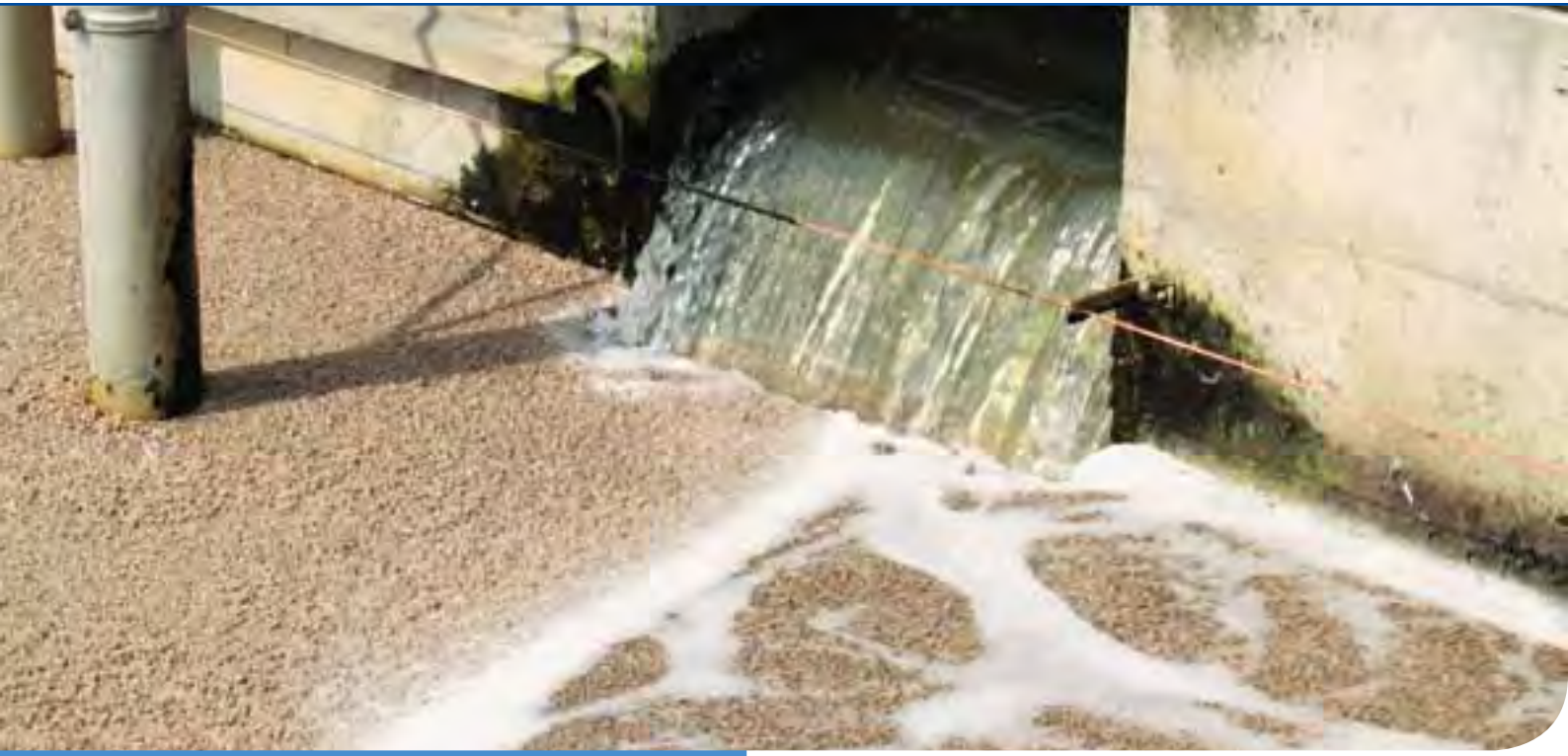

Nitrogen

Nitrogen Measurements: Ammonium · Nitrate · Nitrite

Wastewater treatment processes are concerned with controlling the energy efficient removal of pollutants in the smallest possible space in the shortest possible time.

Required are:

- detailed knowledge of the underlying process
- highest possible transparency of the process steps through corresponding measuring methods

The efficient control of Nitrogen in wastewater systems is possible by making those measurements directly in the wastewater process. This not only ensures purification but above all guarantees economic operation of the entire plant.

Purification processes for the removal of nitrogen from wastewater

Nitrogen is found in a large variety of compounds and forms and is considered to be the ultimate “quick-change artist”. In municipal wastewater it is mainly encountered as a waste product in the form of urea, which is already converted in part to ammonium nitrogen by ammonification.

In the aeration basin, the initial step of nitrification consists in oxidizing the nitrogen present in wastewater via nitrite to nitrate, for which oxygen is required. During subsequent denitrification the nitrate (NO_3^-) is further converted to elemental nitrogen N_2 under the absence of oxygen. This nitrogen in gas form is harmlessly released into the environment.

Due to the various framework conditions and different biologically active groups of microorganisms, both methods are conducted in two fundamentally separate processes. The temporal and spatial sequence can be adapted to local conditions.

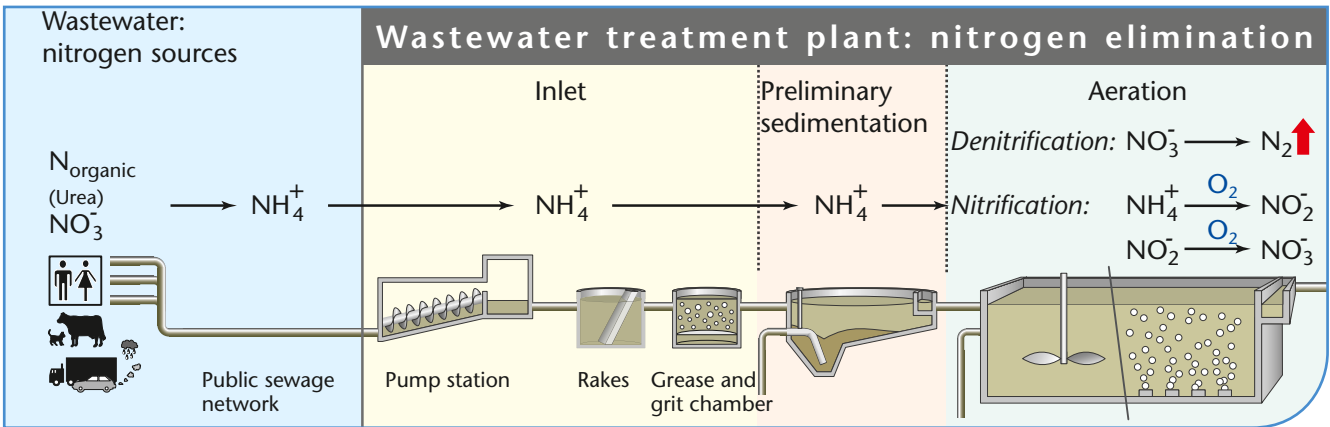

Measuring method for tracing nitrogen elimination

In addition to oxygen, measurements of ammonium and nitrate relevant for the nitrification and denitrification are determined in modern wastewater treatment plants. The immediately available parameters allow the control to be directly optimized. This guarantees efficient wastewater purifications. This results in reduced energy costs. Since nitrite is only present in very low concentrations under normal nitrification (about 0.1 mg/L), it is usually regarded as a minor measurement parameter in wastewater treatment plants. However, the nitrite-oxidizing organisms are inhibited by unfavorable conditions or toxic substances, which can cause elevated nitrite concentrations in the effluent. Since nitrite acts as a powerful fish poison, higher nitrite concentrations may not be discharged into natural waters. The measurement of nitrite as monitoring parameter using an appropriate online measurement technology is therefore also useful in treatment plants.

The following example of intermittent procedure illustrates the advantage of direct measurement of selected parameters.

Nitrification and denitrification are conducted in succession in the same basin. In the nitrification phase ammonium is oxidized using oxygen to form nitrate. The nitrate content increases accordingly. In the denitrification phase nitrate is reduced to form gaseous nitrogen; ammonium is formed from residual organic nitrogen. Ammonium and nitrate curves display opposite behavior.

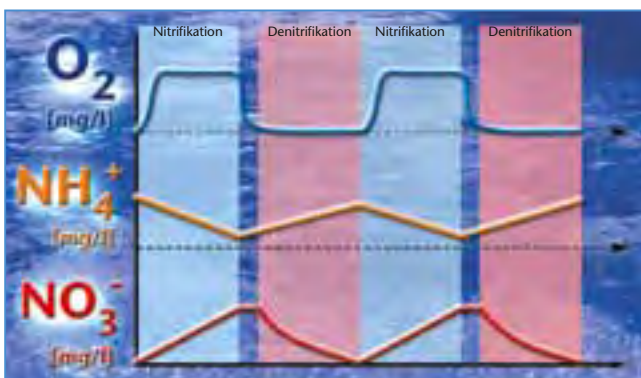

Example: intermittent nitrification/denitrification

Correlation between the individual procedure measurements of dissolved oxygen, ammonium and nitrate

In order to minimize energy consumption in the aeration basin, a preferably efficient and low O₂ input should be targeted for complete nitrogen oxidation. Furthermore, the optimum efficiency of denitrification stages with anaerobic or anoxic conditions must be ensured. For optimum growth of nitric bacteria, higher concentrations of dissolved oxygen are generally required than for the pure decomposition of organic carbon compounds. The online measurement of the selected parameter of ammonium, which provides the possibility of NH₄-N controlled operation, makes the nitrification process transparent and offers significantly higher potential for energy saving of certainty than in pure O₂ controlled operation. A combined measurement of NH₄-N and O₂ is suitable for plant operation, as this prevents the formation of bulking sludge in the lower range and limits the oxygen input should interferences occur in NH₄-N decomposition (e.g. caused by a disturbed nutrient ratio of carbon : nitrogen : phosphate). This can create significant savings potentials.

Parameter section

Dissolved Oxygen

pH/ORP

Conductivity

Turbidity/Suspended Solids

Nitrogen

Carbon: COD/TOC/DOC/BOD/SAC

Phosphate

Sludge level

Direct measuring procedures for determining ammonium and nitrate

The dynamics of the controllable process and the used measuring system are of great importance for the measuring and control technology. Here applies: the faster the control process and disturbance variables, the shorter recognition times are expected from the measuring system.



See page 43 for various measuring systems and applications.

In-situ ISE sensors







These control engineering demands led to the development of in-situ ISE (ion-selective) measuring techniques, which are capable of directly recording the respective selected parameter ammonium and nitrate during the process both quickly and without sample preparation.

In-situ UV-VIS and UV sensors

In-situ UV-VIS spectrometric sensors represent a precise measuring technique with long-term stability, which permit quasi-continuous recording of the selected parameter NO_3 and NO_2 in the smallest measuring cycles of minutes. The disturbance variables for optical measuring, such as turbidity/suspended solids, are eliminated by spectral recording. Thanks to integrated ultrasonic cleaning, a very long maintenance-free operation is possible.

Analyzers

Depending on measurements and applications, analyzer systems require standard and reagent solutions as well as sample preparation. Measuring intervals and automatic cleaning cycles are adjustable. These instruments automatically and recurrently compare measurements against reference standards and deliver high precision measurement values.

WTW Measuring Systems for Nitrogen				*Measurement in aeration basin		
● recommended by WTW		○ conditionally applicable		Ammonium and Nitrate	Nitrate and Nitrite	
System		Ammonium	Ammonium and Nitrate	Nitrate	Nitrate and Nitrite	
Sensor/Module	 IQ SENSOR NET AmmoLyt® Plus 700 IQ	 TresCon® Module OA 110 <i>for mounting in TresCor® system</i>	 IQ SENSOR NET VARION® Plus 700 IQ	 IQ SENSOR NET NitraLyt® Plus 700 IQ	 TresCon® Module ON 210/OS 210 <i>for mounting in TresCor® system</i>	 IQ SENSOR NET NitraVis® 700 IQ (NI)
Measured Variable	NH ₄	NH ₄	NH ₄ and NO ₃	NO ₃	NO ₂ and NO ₃	
Inlet (determination of load)	●	○	●	●	●	
Aeration (regulation and control)	●	●	●	●	●	
Effluent (monitoring)	○	●	○	○	●	
Autom. Cleaning	compressed air	cleaning solution	compressed air	compressed air	cleaning solution	
Cleaning Cycles	variable	automatic 6/12/24 h	variable	variable	automatic 6/12/24 h	
Measuring	in-situ	after sample preparation*	in-situ	in-situ	after sample preparation*	
Sample Preparation	none	PurCon®/PurCon® Insitu*	none	none	PurCon®/PurCon® Insitu*	
Measuring Interval	continuous	adjustable	continuous	continuous	adjustable	
Response Time	quick	medium	quick	quick	quick	
Measuring Method	ISE (ion-selective)	gas-sensitive	ISE (ion-selective)	ISE (ion-selective)	UV-VIS and UV spectrometric	
Accuracy	good	high	good	good	high	
Cross Sensitivity	yes/potassium, compensation	none	yes, automatic compensation	yes/chloride, compensation	autom. compensated (spectrum)	
Calibration	factory calibration	automatic 6/12/24 h	factory calibration	factory calibration	not necessary	
Investment Costs	low	medium	low	low	medium	
Additional Costs	—	sample preparation/pump may be required	—	—	sample preparation/pump may be required	
Operational Costs	low	medium	low	low	—	
Consumables	electrodes	calibration standard/reagent cleaning solution/E pack	electrodes	electrodes	calibration standard cleaning solution/E pack	

Sludge level	Phosphate	Carbon: COD/TOC/DOC/BOD/SAC	Nitrogen	Turbidity/Suspended Solids	Conductivity	pH/ORP	Dissolved Oxygen	Parameter section
--------------	-----------	-----------------------------	----------	----------------------------	--------------	--------	------------------	-------------------

Improve your plant process values – invest and save

WTW ISE sensors

- As easy as measuring pH
- The original – reliable results through established technology
- No chemicals used

Measurement methods of ISE sensors

Ion-selective (ISE) on-line measurements of ammonium and nitrate have been applied for several years in the analytics of modern sewage systems.

WTW has provided ISE measurements of ammonium and nitrate in addition to the traditional wet chemical measurement using analyzers for more than the past 10 years.

Same as the pH measuring, the ISE measuring is based on the selectivity of membranes towards special material and is accordingly easy with the handling.

A tension ΔE is caused due to the selectivity between the work and reference electrode. This tension can be read as measuring value by using a transformer.

WTW ISE electrodes are characterized by highest stability. When used in typical applications they are calibration-free for their entire lifetime. The continuous measurement of ammonium and nitrate that works without sample preparations using ISE electrodes enables an optimization of the plant in respect to the cleaning performance and energy consumption.

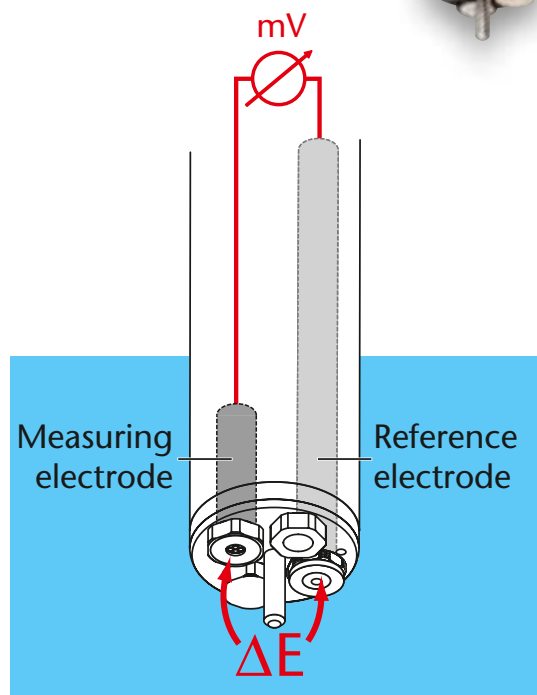

$$\Delta E = E_{(ISE)} - E_{(Ref)}$$



NEW

ISE and Spectral Sensors

WTW Spectral sensors

- In-situ sensors
- Precise optical measurement
- No chemicals or consumables

Measuring principle of the spectral on-line sensors for nitrate, nitrite and COD

The spectral measurement of nitrate and nitrite by WTW is based on the principle of an absorption measurement; nitrate and nitrite ions absorb light in the UV range. The absorption measurement of 256 wavelengths over a wide wavelength range is the so-called absorption spectrum. From the high information content of the measured spectrum, the measured values are calculated using evaluation models. The evaluation models are based on methods and characteristics, which were obtained from a variety of measurements and long-term analyses. By using the entire information content of the spectrum, it is possible to determine the parameters, several parameters at a time and simultaneously eliminate cross-sensitivities of individual parameters and interference effects such as turbidity.

- By using UV-VIS sensors (wavelength range of 200 - 720 nm), nitrate and carbon parameters (COD, BOD, TOC, SAC) and TSS can be measured.
- In order to distinguish nitrate and nitrite, UV sensors (wavelength range of 200-390 nm) are required. These sensors can also determine carbon parameters (COD, BOD, TOC, SAC).

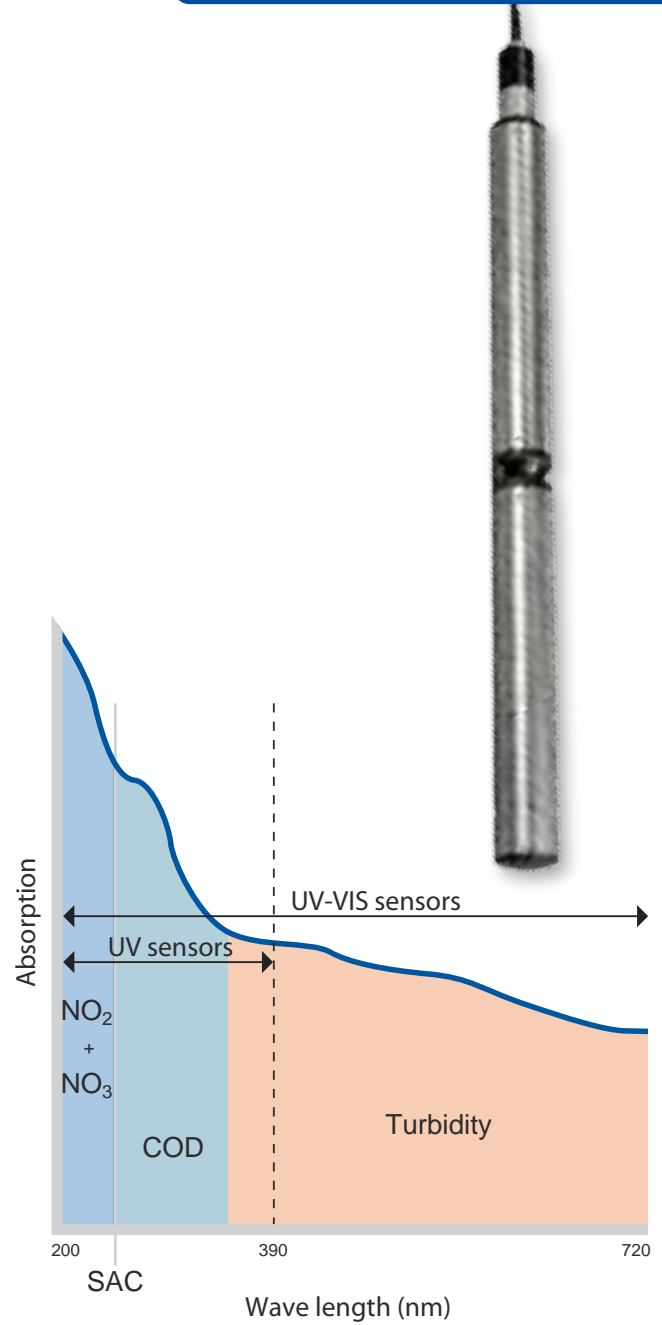

Parameter section
Dissolved Oxygen
pH/ORP
Conductivity
Turbidity/Suspended Solids
Nitrogen
Carbon: COD/TOC/DOC/BOD/SAC
Phosphate
Sludge level

Measuring principle UV-V I S

1	Light source
2	Sender of the optical system
3	Measuring gap between the measurement windows
4	Receiver of the optical system
5	Detector
6	Measuring beam
7	Reference beam
8	Connector for the optional compressed air cleaning system

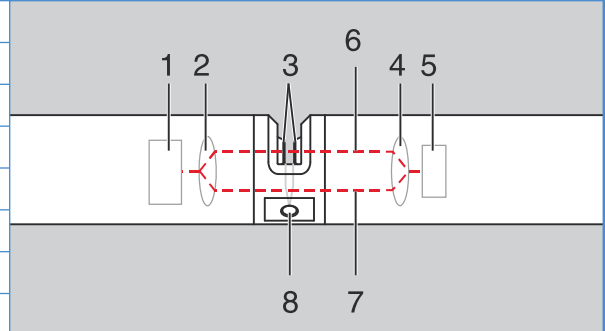

VARiON[®]Plus 700 IQ



- In-situ combination sensor for ammonium and nitrate
- 2 compensated parameters simultaneous
- Economic, cost-effective
- Calibration-free, long stability

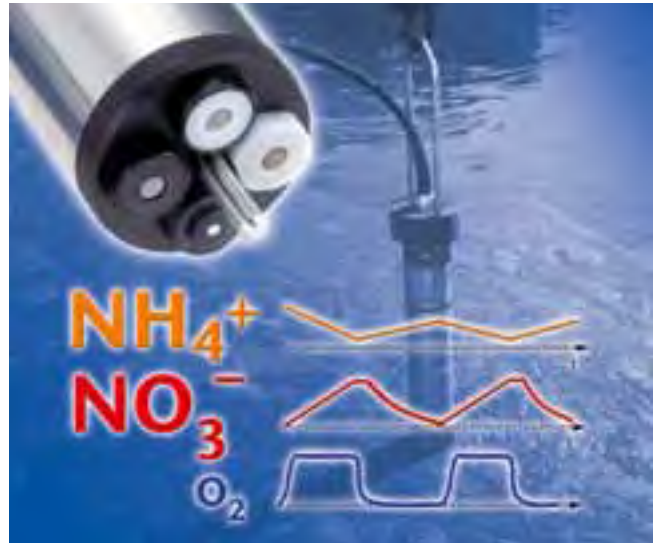

Ammonium and Nitrate ion-selective with automatic compensation of interferences

Ion-selective measurements directly in process – reliable 24 hours a day

The highly variable ionic sensor VARiON[®]Plus allows:

- The continuous measurement of ammonium – with online compensation of potassium ion interference by using potassium ISE.
- The new electrode VARiON[®]Plus NO₃ enables the measuring of nitrate without chloride compensation electrode.
- You can measure ammonium and nitrate using one sensor with perfect gradient display.

For measurement, simply insert the suitable electrode into the sensor, everything else is working automatically. The display shows the already compensated values. The potassium measuring value can be displayed optionally. These values are available via the 0/4–20 mA analog outputs or via the digital output PROFIBUS or Modbus.

Possible configurations

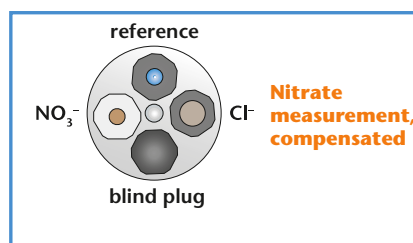
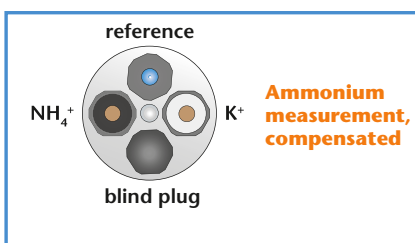

IQ-LabLink

With the initial installation of VARiON®Plus the dependency of the used electrode reference values for ammonium, nitrate, chloride and potassium is determined by a photometric system and can be adapted with VARiON®Plus.

The measurement data is required for ensuring a precise matrix adjustment.

For enhancing the data transfer between the laboratory spectrophotometers photoLab® 6100/6600 and



VARiON®Plus, a USB memory stick in combination with the IQ-LabLink function can be used for the MIQ/TC 2020 XT to automatically read the data and store it on the VARiON®Plus.

- Safe, simple and fast data transfer
- Automatic verification check of data

Technical Data VARiON®Plus																																	
Maximum Configuration	Common reference electrode, two measuring electrodes, one compensation electrode																																
	<table border="1"> <thead> <tr> <th>Ammonium Measurement</th> <th>Nitrate Measurement</th> </tr> </thead> <tbody> <tr> <td> Integrable Electrodes: Reference Electrode: VARiON®Plus Ref Measuring Electrode: VARiON®Plus NH₄ Compensation Electrode: VARiON®Plus K </td> <td> VARiON®Plus NO₃ VARiON®Plus Cl </td> </tr> <tr> <td> Measuring Ranges / Resolution NH₄-N: 1 ... 1,000 mg/l / 1 mg/l; 0.1 ... 100 mg/l / 0.1 mg/l NH₄⁺: 1 ... 1,290 mg/l / 1 mg/l; 0.1 ... 129.0 mg/l / 0.1 mg/l K⁺: 1 ... 1,000 mg/l / 1 mg/l </td> <td> Measuring Ranges / Resolution NO₃-N: 1 ... 1,000 mg/l / 1 mg/l; 0.1 ... 100 mg/l / 0.1 mg/l NO₃⁻: 5 ... 4,500 mg/l / 1 mg/l; 0.5 ... 450.0 mg/l / 0.1 mg/l Cl⁻: 1 ... 1,000 mg/l / 1 mg/l </td> </tr> <tr> <td> Compensation Ranges NH₄-N: 1 ... 1,000 mg/l / 1 mg/l; 0.1 ... 100 mg/l / 0.1 mg/l NH₄⁺: 1 ... 1,290 mg/l / 1 mg/l; 0.1 ... 129.0 mg/l / 0.1 mg/l K⁺: 1 ... 1,000 mg/l / 1 mg/l </td> <td> Compensation Ranges NH₄-N: 1 ... 1,000 mg/l / 1 mg/l; 0.1 ... 100 mg/l / 0.1 mg/l NH₄⁺: 1 ... 1,290 mg/l / 1 mg/l; 0.1 ... 129.0 mg/l / 0.1 mg/l K⁺: 1 ... 1,000 mg/l / 1 mg/l </td> </tr> <tr> <td> Temperature Measurement and Compensation </td> <td> Integrated NTC thermistor, Range 32 °F ... 104 °F (0 °C ... +40 °C), Accuracy ±0.5 K, Resolution 0.1 K, t₉₅ <20 s </td> </tr> <tr> <td> Calibration Procedures </td> <td> 2-point-calibration with multiple standard solutions, calibration against any reference value </td> </tr> <tr> <td> Ambient Conditions </td> <td> Operating temperature: 32 °F ... 104 °F (0 °C ... +40 °C), storing temperature: 32 °F ... 104 °F (0 °C ... +40 °C) </td> </tr> <tr> <td> pH Range </td> <td> pH 4 ... pH 8.5 pH 4 ... pH 11 </td> </tr> <tr> <td> Measuring Accuracy in laboratory standard solutions </td> <td> ±5 % of measured value ±0.2 mg/l in standard solutions </td> </tr> <tr> <td> Working Life (typically) </td> <td> All electrodes: 18 months (in typical application - sewage plants) </td> </tr> <tr> <td> Mechanical </td> <td> Sensor body: V4A stainless steel 1.4571 Protective cup: POM Temperature sensor: V4A stainless steel 1.4571 Protection rating: IP 68 (0.2 bar, with installed electrodes) Electrode connector: POM </td> </tr> <tr> <td> Max. Pressure </td> <td> Maximum 0.2 bar (incl. SACIQ sensor connection cable, with installed electrodes) </td> </tr> <tr> <td> Power Consumption </td> <td> 0.2 watts </td> </tr> <tr> <td> Dimensions </td> <td> 14.45 x 1.57 in. (367 x 40 mm, length x diameter), incl. SACIQ sensor connection cable </td> </tr> <tr> <td> Weight </td> <td> Approx. 1.76 lb (800 g, without electrodes, without SACIQ sensor connection cable) </td> </tr> <tr> <td> Guaranty </td> <td> VARiON®Plus 700 IQ: 2 years for defects of quality </td> </tr> </tbody> </table>	Ammonium Measurement	Nitrate Measurement	Integrable Electrodes: Reference Electrode: VARiON®Plus Ref Measuring Electrode: VARiON®Plus NH ₄ Compensation Electrode: VARiON®Plus K	VARiON®Plus NO ₃ VARiON®Plus Cl	Measuring Ranges / Resolution NH ₄ -N: 1 ... 1,000 mg/l / 1 mg/l; 0.1 ... 100 mg/l / 0.1 mg/l NH ₄ ⁺ : 1 ... 1,290 mg/l / 1 mg/l; 0.1 ... 129.0 mg/l / 0.1 mg/l K ⁺ : 1 ... 1,000 mg/l / 1 mg/l	Measuring Ranges / Resolution NO ₃ -N: 1 ... 1,000 mg/l / 1 mg/l; 0.1 ... 100 mg/l / 0.1 mg/l NO ₃ ⁻ : 5 ... 4,500 mg/l / 1 mg/l; 0.5 ... 450.0 mg/l / 0.1 mg/l Cl ⁻ : 1 ... 1,000 mg/l / 1 mg/l	Compensation Ranges NH ₄ -N: 1 ... 1,000 mg/l / 1 mg/l; 0.1 ... 100 mg/l / 0.1 mg/l NH ₄ ⁺ : 1 ... 1,290 mg/l / 1 mg/l; 0.1 ... 129.0 mg/l / 0.1 mg/l K ⁺ : 1 ... 1,000 mg/l / 1 mg/l	Compensation Ranges NH ₄ -N: 1 ... 1,000 mg/l / 1 mg/l; 0.1 ... 100 mg/l / 0.1 mg/l NH ₄ ⁺ : 1 ... 1,290 mg/l / 1 mg/l; 0.1 ... 129.0 mg/l / 0.1 mg/l K ⁺ : 1 ... 1,000 mg/l / 1 mg/l	Temperature Measurement and Compensation	Integrated NTC thermistor, Range 32 °F ... 104 °F (0 °C ... +40 °C), Accuracy ±0.5 K, Resolution 0.1 K, t ₉₅ <20 s	Calibration Procedures	2-point-calibration with multiple standard solutions, calibration against any reference value	Ambient Conditions	Operating temperature: 32 °F ... 104 °F (0 °C ... +40 °C), storing temperature: 32 °F ... 104 °F (0 °C ... +40 °C)	pH Range	pH 4 ... pH 8.5 pH 4 ... pH 11	Measuring Accuracy in laboratory standard solutions	±5 % of measured value ±0.2 mg/l in standard solutions	Working Life (typically)	All electrodes: 18 months (in typical application - sewage plants)	Mechanical	Sensor body: V4A stainless steel 1.4571 Protective cup: POM Temperature sensor: V4A stainless steel 1.4571 Protection rating: IP 68 (0.2 bar, with installed electrodes) Electrode connector: POM	Max. Pressure	Maximum 0.2 bar (incl. SACIQ sensor connection cable, with installed electrodes)	Power Consumption	0.2 watts	Dimensions	14.45 x 1.57 in. (367 x 40 mm, length x diameter), incl. SACIQ sensor connection cable	Weight	Approx. 1.76 lb (800 g, without electrodes, without SACIQ sensor connection cable)	Guaranty	VARiON®Plus 700 IQ: 2 years for defects of quality
Ammonium Measurement	Nitrate Measurement																																
Integrable Electrodes: Reference Electrode: VARiON®Plus Ref Measuring Electrode: VARiON®Plus NH ₄ Compensation Electrode: VARiON®Plus K	VARiON®Plus NO ₃ VARiON®Plus Cl																																
Measuring Ranges / Resolution NH ₄ -N: 1 ... 1,000 mg/l / 1 mg/l; 0.1 ... 100 mg/l / 0.1 mg/l NH ₄ ⁺ : 1 ... 1,290 mg/l / 1 mg/l; 0.1 ... 129.0 mg/l / 0.1 mg/l K ⁺ : 1 ... 1,000 mg/l / 1 mg/l	Measuring Ranges / Resolution NO ₃ -N: 1 ... 1,000 mg/l / 1 mg/l; 0.1 ... 100 mg/l / 0.1 mg/l NO ₃ ⁻ : 5 ... 4,500 mg/l / 1 mg/l; 0.5 ... 450.0 mg/l / 0.1 mg/l Cl ⁻ : 1 ... 1,000 mg/l / 1 mg/l																																
Compensation Ranges NH ₄ -N: 1 ... 1,000 mg/l / 1 mg/l; 0.1 ... 100 mg/l / 0.1 mg/l NH ₄ ⁺ : 1 ... 1,290 mg/l / 1 mg/l; 0.1 ... 129.0 mg/l / 0.1 mg/l K ⁺ : 1 ... 1,000 mg/l / 1 mg/l	Compensation Ranges NH ₄ -N: 1 ... 1,000 mg/l / 1 mg/l; 0.1 ... 100 mg/l / 0.1 mg/l NH ₄ ⁺ : 1 ... 1,290 mg/l / 1 mg/l; 0.1 ... 129.0 mg/l / 0.1 mg/l K ⁺ : 1 ... 1,000 mg/l / 1 mg/l																																
Temperature Measurement and Compensation	Integrated NTC thermistor, Range 32 °F ... 104 °F (0 °C ... +40 °C), Accuracy ±0.5 K, Resolution 0.1 K, t ₉₅ <20 s																																
Calibration Procedures	2-point-calibration with multiple standard solutions, calibration against any reference value																																
Ambient Conditions	Operating temperature: 32 °F ... 104 °F (0 °C ... +40 °C), storing temperature: 32 °F ... 104 °F (0 °C ... +40 °C)																																
pH Range	pH 4 ... pH 8.5 pH 4 ... pH 11																																
Measuring Accuracy in laboratory standard solutions	±5 % of measured value ±0.2 mg/l in standard solutions																																
Working Life (typically)	All electrodes: 18 months (in typical application - sewage plants)																																
Mechanical	Sensor body: V4A stainless steel 1.4571 Protective cup: POM Temperature sensor: V4A stainless steel 1.4571 Protection rating: IP 68 (0.2 bar, with installed electrodes) Electrode connector: POM																																
Max. Pressure	Maximum 0.2 bar (incl. SACIQ sensor connection cable, with installed electrodes)																																
Power Consumption	0.2 watts																																
Dimensions	14.45 x 1.57 in. (367 x 40 mm, length x diameter), incl. SACIQ sensor connection cable																																
Weight	Approx. 1.76 lb (800 g, without electrodes, without SACIQ sensor connection cable)																																
Guaranty	VARiON®Plus 700 IQ: 2 years for defects of quality																																

Ordering Information		
VARiON®Plus SETs	Consisting of probe, reference electrode, measurement and compensation electrodes	Order No.
VARiON®Plus A comp SET	Ammonium measurement, compensated	107 060
VARiON®Plus N comp SET	Nitrate measurement, compensated	107 062
VARiON®Plus AN/A comp SET	Ammonium measurement, compensated, plus nitrate measurement	107 066
VARiON®Plus AN/N comp SET	Nitrate measurement, compensated, plus ammonium measurement	107 068
Standard Solutions	for VARiON®Plus, AmmoLyt®Plus, NitaLyt®Plus	Order No.
VARiON®Plus/ES-1	Combined standard 1 (low concentration), 1000 ml	107 050
VARiON®Plus/ES-2	Combined standard 2 (high concentration), 1000 ml	107 052
Accessories	For automatic cleaning. Recommended for permanent operation.	Order No.
MIQ/CHV PLUS	Valve module for automatic cleaning by compressed air controlled directly via the IQ SENSOR NET bus	480 018
DIQ/CHV	Valve module for automatic compressed air cleaning for System 182; accessible by means of an DIQ/S 182 relay	472 007
CH	Cleaning head	900 107



AmmoLyt® Plus



- In-situ ammonium sensor with potassium compensation
- Economic, cost-effective
- Calibration-free, long term stable
- Short response time

Ammonium Measurement directly in the Medium – without Sample Preparation

The continuous measuring of O_2 and NH_4 can result in significant savings through:

- energy-optimized operation due to demand-oriented regulation of aerator aggregates,
- adherence to critical values or reduction of wastewater charges.
- The potassium measuring value can be displayed optionally.

The low investment costs for the system can thus be amortized after a short period.

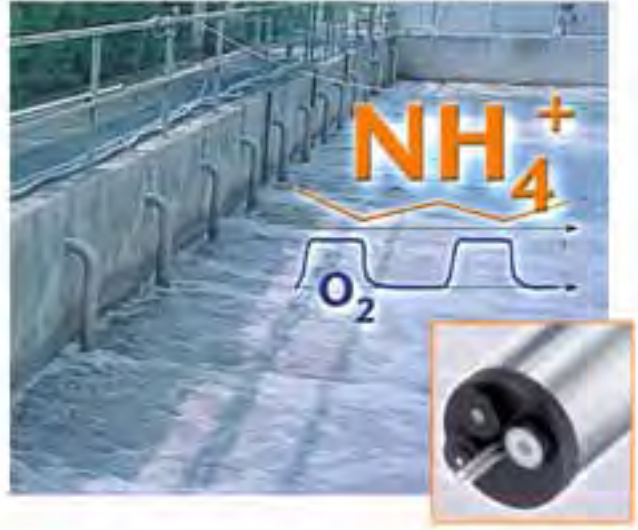

IQ-LabLink

With the initial installation of AmmoLyt^{®Plus} the dependency of the used electrode reference values for ammonium or potassium is determined by a photometric system and can be adapted with AmmoLyt^{®Plus}.

The measurement data is required for ensuring a precise matrix adjustment.

For enhancing the data transfer between the laboratory spectrophotometers photoLab[®] 6100/6600 and AmmoLyt^{®Plus}, a USB memory stick in combination with the IQ-LabLink function can be used for the MIQ/TC 2020 XT to automatically read the data and store it on AmmoLyt^{®Plus}.

- Safe, simple and fast data transfer
- Automatic verification check of data



Technical Data AmmoLyt ^{®Plus}	
Appropriate Electrode	Reference electrode VARiON ^{®Plus} Ref, Measuring electrode VARiON ^{®Plus} NO ₃ , Compensation electrode VARiON ^{®Plus} Cl
Measuring Ranges/Resolution	NH ₄ -N: 1 ... 1000 mg/l / 1 mg/l; 0.1 ... 100 mg/l / 0.1 mg/l NH ₄ ⁺ : 1 ... 1290 mg/l / 1 mg/l; 0.1 ... 129.0 mg/l / 0.1 mg/l
Compensation Range:	K ⁺ : 1 ... 1000 mg/l / 1 mg/l
Temp. Measurement and Compensation	Integrated NTC thermistor Range: 32 ... 104 °F (0 ... +40 °C), Accuracy ±0.5 K, resolution 0.1 K, t ₉₅ <20 s
Calibration Procedures	Matrix adjustment against any reference value, 2-point-calibration possible with multiple standard solution
Ambient Conditions	Integrated NTC thermistor Range: 32 ... 104 °F (0 ... +40 °C), Accuracy ±0.5 K, resolution 0.1 K
pH Range	pH 4 ... pH 8.5
Measuring Accuracy in laboratory standard solutions	±5 % of measured value ±0.2 mg/l in standard solutions
Working Life (typically)	All electrodes: 18 months (in typical application - sewage plants)
Mechanical	Sensor body: V4A Stainless Steel 1.4571 Protective cap: POM, Temp. sensor: V4A Stainless Steel 1.4571 Protection rating: IP 68 (0.2 bar, with installed electrodes) Electrode connector: POM
Max. Pressure	Maximum 0.2 bar (incl. SACIQ sensor connection cable; with installed electrodes)
Power Consumption	0.2 watts
Dimensions	15.43 x 1.57 in. (392 x 40 mm, length x diameter), incl. sensor connection cable SACIQ
Weight	Approx. 1.48 lb (670 g, without electrode, without sensor connection cable)
Guaranty	AmmoLyt ^{®Plus} 700 IQ: 2 years for defects of quality

Ordering Information		Order No.
AmmoLyt^{®Plus}-System		
AmmoLyt^{®Plus} 700 IQ	Robust digital armature for ion-selective electrodes (VARiON ^{®Plus} Ref/VARiON ^{®Plus} NH ₄ /VARiON ^{®Plus} K; not included in the delivery set)	107 080
VARiON^{®Plus} Ref	Reference electrode for VARiON ^{®Plus} 700 IQ/AmmoLyt ^{®Plus} 700 IQ/NitraLyt ^{®Plus} 700 IQ	107 042
VARiON^{®Plus} NH₄	Ammonium electrode	107 044
VARiON^{®Plus} K	Electrode for dynamic potassium compensation with ammonium measuring	107 046
CH	Cleaning head	900 107
MIQ/CHV PLUS	Valve module for automatic cleaning by compressed air controlled directly via the IQ SENSOR NET bus	480 018
DIQ/CHV	Valve module for automatic compressed air cleaning for System 182; accessible by means of an DIQ/S 182 relay	472 007



* on armature

Standard Solutions see brochure "Product Details"



TresCon® OA 110

- Continuous measurements
- Automatic calibration
- Short response time

Online ammonium measurement

- Continuous ammonium value monitoring in sewage plant effluent
- Analysis of the ammonium-nitrogen pollution in surface waters
- Monitoring water treatment plants



Measuring Principle

The continuous determination of ammonium in the OA 110 module is carried out according to the potentiometric measuring principle with a gas-sensitive NH_3 electrode. Sodium hydroxide is added to the thermostatted sample to convert the ammonium dissolved in the medium into undissociated ammonia gas. The gaseous ammonia alters the pH registered by the measuring electrode; the alteration is a direct measure of the ammonium concentration in the sample.

Technical Data OA 110

	Standard 1	Standard 2*
Measuring Ranges	$\text{NH}_4\text{-N}$: 0.1 ... 1000 mg/l; 0.01 ... 71.00 mmol/l $\text{NH}_4\text{+}$: 0.1 ... 1280 mg/l; 0.01 ... 71.00 mmol/l	$\text{NH}_4\text{-N}$: 0.05 ... 10 mg/l; 0.005 ... 0.71 mmol/l* $\text{NH}_4\text{+}$: 0.05 ... 12.8 mg/l; 0.005 ... 0.71 mmol/l*
Resolution (Display)	Range: 0.10 ... 10 mg/l: 0.01 mg/l 10.0 ... 100 mg/l: 0.1 mg/l 100 ... 1000/1280 mg/l: 1 mg/l	Range: 0.05 ... 10 mg/l: 0.01 mg/l*
Accuracy	$\pm 5\%$ of the measured value ± 0.2 mg/l at < 1 mg/l $\text{NH}_4\text{-N}$ $\pm 5\%$ of the measured value ± 0.1 mg/l at 1.0 ... 100 mg/l $\text{NH}_4\text{-N}$	$\pm 5\%$ of the measured value ± 0.05 mg/l at < 1 mg/l $\text{NH}_4\text{-N}^*$ $\pm 5\%$ of the measured value ± 0.1 mg/l at 1.0 ... 10 mg/l $\text{NH}_4\text{-N}^*$
Coefficient of Variation of Method	Range: 0.10 ... 10 mg/l: 3 % 10.0 ... 100 mg/l: 4 % 100 ... 1000/1280 mg/l: 5 % (values for calibration with suitable standard solutions)	
Response time	< 3 min (after alternation in concentration at module input)	
Measuring Interval	Continuous Mode and 10, 15, 20, 25, 30 min interval selectable, AutoAdapt, Interval-Program	
Calibration	Automatic 2-point calibration (AutoCal) with two standard solutions	
Sample input	Approx. 0.3 l/h, solids content < 50 mg/l	
Consumption	Reagent, 10 l: 14/30/50 days at measuring intervals cont./20/30 min	
	Standard solutions A/B, 1.5 l: 60 days with 24 Std. calibration interval	
	Cleaning solution 1.5 l: 60 days with 24 Std. cleaning interval	
Maintenance Interval	Every 6 months	
Guaranty	2 years for defects of quality	

Ordering Information

		Order No.
OA 110	Separate TresCon® analyzer module for ammonium-nitrogen for extension of an existing TresCon® system (requires 1 measuring place)	820 008
TresCon® A 111	TresCon®-basic instrument with analysis module OA 110 for ammonium-nitrogen (wall mounting, space for 2 further modules)	8A-10030
TCU/A111	TresCon® Uno ammonium: single parameter system ammonium with analysis module OA 110 for ammonium-nitrogen	820 101



Accessories and consumables see brochure "Product Details"

* around calibration standard

NitraLyt® Plus



- In-situ nitrate sensor with optional chloride compensation
- Economic, cost-effective
- Calibration-free, long term stable
- Short response time

Nitrogen Elimination Process – monitored, optimized, cost effective

The optimization of nitrification/denitrification during wastewater treatment is simplified even further by the new NitraLyt® Plus system:

- Nitrate is also directly measurable during the process in addition to oxygen and ammonium.
- Measured values are promptly available and can be used directly to control the process.
- Low investment and maintenance costs (automatic compressed air cleaning system).

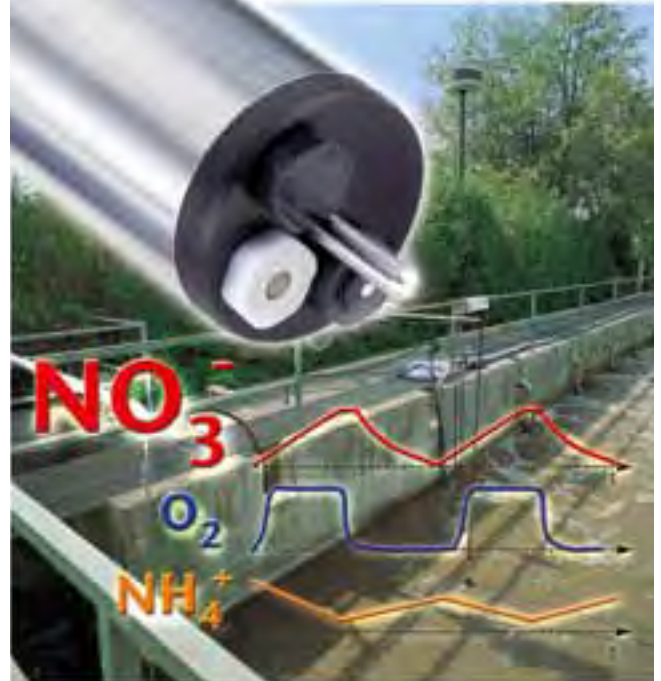

Parameter section

Dissolved Oxygen

pH/ORP

Conductivity

Turbidity/Suspended Solids

Nitrogen

Carbon: COD/TOC/DOC/BOD/SAC

Phosphate

Sludge level

IQ-LabLink

With the initial installation of NitraLyt®Plus the dependency of the used electrode reference values for nitrate and chloride is determined by a photometric system and can be adapted with NitraLyt®Plus.

The measurement data is required for ensuring a precise matrix adjustment.

For enhancing the data transfer between the laboratory spectrophotometers photoLab® 6100/6600 and NitraLyt®Plus, a USB memory stick in combination with the IQ-LabLink function can be used for the MIQ/TC 2020 XT to automatically read the data and store it on NitraLyt®Plus.

- Safe, simple and fast data transfer
- Automatic verification check of data



Technical Data NitraLyt®Plus	
Appropriate Electrodes	Reference electrode VARiON®Plus Ref, Measuring electrode VARiON®Plus NO ₃ , Compensation electrode VARiON®Plus Cl
Measuring Ranges/ Resolution	NO ₃ -N: 1 ... 1000 mg/l / 1 mg/l; 0.1 ... 100.0 mg/l / 0.1 mg/l NO ₃ -: 5 ... 4500 mg/l / 5 mg/l; 0.5 ... 450.0 mg/l / 0.5 mg/l Cl ⁻ : 1 ... 1000 mg/l / 1 mg/l
Temp. Measurement and Compensation	Integrated NTC thermistor Range: 32 ... 104 °F (0 °C ... +40 °C), Accuracy ±0.5 K, resolution 0.1 K, t ₉₅ <20 s
Calibration Procedures	Matrix adjustment against any reference value, 2-point-calibration possible with multiple standard solution
Ambient Conditions	Operating temperature: 32 °F ... 104 °F (0 °C ... +40 °C), storing temperature: 32 °F ... 104 °F (0 °C ... +40 °C)
pH Range	pH 4 ... pH 11
Measuring Accuracy in laboratory standard solutions	±5% of measured value ±0.2 mg/l in standard solutions
Working Life (typically)	All electrodes: 18 months (in typical application - sewage plants)
Mechanical	Sensor body: V4A Stainless Steel 1.4571 Protective cap: POM, Temp. sensor: V4A Stainless Steel 1.4571 Protection rating: IP 68 (0.2 bar, with installed electrodes) Electrode connector: POM
Max. Pressure	Maximum 0.2 bar (incl. SACIQ sensor connection cable; with installed electrodes)
Power Consumption	0.2 watts
Dimensions	15.43 x 1.57 in. (392 x 40 mm, length x diameter), incl. sensor connection cable SACIQ
Weight	Approx. 1.48 lb (670 g, without electrode, without sensor connection cable)
Guaranty	NitraLyt®Plus 700 IQ: 2 years for defects of quality

Ordering Information

NitraLyt®Plus-System		Order No.
NitraLyt®Plus 700 IQ	Robust digital armature for ionselective electrodes (VARiON®Plus Ref/VARiON®Plus NO ₃ /VARiON®Plus Cl; not included in the delivery set)	107 080
VARiON®Plus Ref	Reference electrode for VARiON®Plus 700 IQ/AmmoLyt®Plus 700 IQ/NitraLyt®Plus 700 IQ	107 042
VARiON®Plus NO ₃	Nitrate electrode for measuring nitrate with dynamic Cl compensation	107 045
VARiON®Plus Cl	Electrode for dynamic Cl compensation of the nitrate measurement	107 047
CH	Cleaning head	900 107
MIQ/CHV PLUS	Valve module for automatic cleaning by compressed air controlled directly via the IQ SENSOR NET bus	480 018
DIQ/CHV	Valve module for automatic compressed air cleaning for System 182; accessible by means of an DIQ/S 182 relay	472 007



* on armatures

Standard solutions see brochure "Product Details"

NEW

Nitrate/Nitrite Measurement

NitraVis®/NiCaVis®

- High measurement reliability
- Low operating costs
- Simple handling
- Maximum durability

Optical in-situ measurement of nitrate, nitrite, carbon parameters and suspended solids (optional)

The chemical-free spectral measurement allows a precise determination of the measurement parameters for nitrate, nitrite, carbon parameters (COD, BOD, TOC, SAC) and TSS.

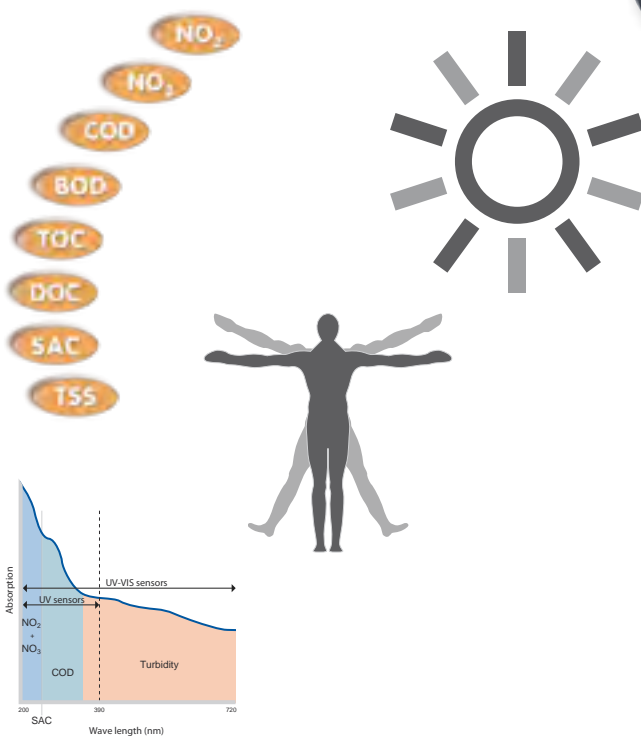

Two spectral types of sensors for different measurement parameters:

- | | |
|---|---|
| <ul style="list-style-type: none"> • UV-VIS sensors (Wavelength range 200-720 nm): • Nitrate • Carbon parameters • TSS | <ul style="list-style-type: none"> • UV sensors (Wavelength range 200-390 nm): • Nitrate • Nitrite • Carbon parameters |
|---|---|



High measuring reliability

- Wide dynamic range and high measurement accuracy. Automatic adjustment of the number of flashes to the current sample matrix, similar to an exposure measurement in cameras, ensure optimized recording level of the detector.
- Excellent measurement repeatability and zero point and long-term stability. 100% symmetrical optics, measurement and reference channel are identical in design, which enables optimal referencing.
- Evaluating the entire measured spectrum from 200 to provide recognition of interferences; calculate these automatically or apply these for compensation.

Simple to use

- Due to the built-in ultrasonic cleaning system, a very long maintenance-free operation is possible. Accumulation of dirt and biofilm formation is gently but very effectively prevented.

Maximum durability

- High-tech materials such as titanium and peek ensure an easy use in almost all media, even corrosive media.

Parameter section
Dissolved Oxygen
pH/ORP
Conductivity
Turbidity/Suspended Solids
Nitrogen
Carbon: COD/TOC/DOC/BOD/SAC
Phosphate
Sludge level

Technical Data NitraVis®/NiCaVis®

Measuring Principle	Spectral Measurement in the UV-VIS Range (200 - 720 nm) / UV range of 200 - 390 nm						
Applications	Municipal wastewater: inlet, aeration, outlet						
Measuring Range Nitrate Standard	NO ₃ -N:	NitraVis® 701 IQ 0.1 ... 100.0 mg/l inlet, aeration	NitraVis® 705 IQ 0.01 ... 25.00 mg/l outlet	NO ₃ -N: — NO ₂ -N: COD	NiCaVis® 705 IQ 0.01 ... 25.00 mg/l — 0.1 ... 800.00 mg/l Municipal wastewater: outlet	NiCaVis® 701 IQ NI 0.1 ... 100 mg/l 0.1 ... 25 mg/l 0.5 ... 4000.0 mg/l inlet, aeration, outlet	NiCaVis® 705 IQ NI 0.01 ... 25 mg/l 0.01 ... 5 mg/l 0.1 ... 800 mg/l outlet
Measuring Range Suspended Solids (Option)	TSS:	0 ... 10.00 g/l inlet, aeration	0 ... 900.0 mg/l outlet	TSS:	—	—	—
Materials	Housing: Titan 3.7035, PEEK Window: Sapphire glass						
Pressure Resistance	≤1 bar						
Ambient Conditions	Operating Temperature: 32 °F ... 113 °F (0 °C ... +45 °C) Storage temperature: 14 °F ... 122 °F (-10 °C ... +50 °C)						
Flow velocity	≤3 m/s						
pH range	pH 4 ... pH 12						
Dimensions	31.57 x 2.36 in. (802 x 59.9 mm; length x diameter)						
Weight	Approx. 8.82 lb (4 kg)						
Guaranty	2 years for defects of quality						

Ordering Information

UV-VIS sensors NitraVis®	Supplied with multifunctional slide and Shock-Absorption-Rings, without connection cable (SACIQ order separately)	Order No.
NitraVis® 701 IQ	Optical nitrate sensor, with spectral processing of the UV-VIS range, for in-situ measurement in inlet / BNR part of municipal wastewater treatment plants, with integrated ultrasonic cleaning.	481 044
NitraVis® 701 IQ TS Double sensor	Optical nitrate/TSS sensor, with spectral processing of the UV-VIS range, for in-situ measurement in inlet / BNR part of municipal wastewater treatment plants, with integrated ultrasonic cleaning.	481 045
NitraVis® 705 IQ	Optical nitrate, with spectral processing of the UV-VIS range, for in-situ measurement in the effluent of municipal wastewater treatment plants, with integrated ultrasonic cleaning.	481 046
NitraVis® 705 IQ TS Double sensor	Optical nitrate/TSS, with spectral processing of the UV-VIS range, for in-situ measurement in the effluent of municipal wastewater treatment plants, with integrated ultrasonic cleaning.	481 047
UV-VIS sensors NiCaVis®	Supplied with multifunctional slide and Shock-Absorption-Rings, without connection cable (SACIQ order separately)	Order No.
NiCaVis® 705 IQ Double sensor	Optical nitrate and COD/TOC/DOC/BOD/SAC probe, with spectral processing of the UV/VIS range, for in-situ measurement in effluent of municipal wastewater treatment plants, with integrated ultrasonic cleaning.	481 052
UV sensors NiCaVis®	Delivery set: sensor, shock-absorption-rings, calibration feed, manual	Order No.
NiCaVis 701 IQ NI	UV sensor for the measurement of nitrate, nitrite, COD _{total} , COD _{soluble} , TOC, BOD, DOC, SAC _{total} , SAC _{soluble} and UVT ₂₅₄ in inlet, BNR part and effluent of municipal wastewater treatment plants.	481 054
NiCaVis 705 IQ NI	UV sensor for the measurement of nitrate, nitrite, COD _{total} , COD _{soluble} , TOC, BOD, DOC, SAC _{total} , SAC _{soluble} and UVT ₂₅₄ in the effluent of municipal wastewater treatment plants.	481 055
Accessories	for additional compressed air cleaning system (optional)	Order No.
Cleaning Air Box	Cleaning air box with compressor, 230 VAC with air-filter	480 019
MIQ/CHV PLUS	Valve module for automatic cleaning by compressed air; controlled directly via the IQ SENSOR NET Bus	480 018
DIQ/CHV	Valve module for the automatic compressed air cleaning for System 182; accessible by means of an DIQ/S 182 relay	472 007
SET/AP	Compressed air cleaning set: 15 m compressed air tubing incl. fittings, additional modules and components, must be ordered separately	481 075



TresCon® ON 210/OS 210

- Reagent-free measuring method
- 4-beam measuring method for optimal background compensation
- Simultaneous nitrate and SAC determination (OS 210)

Nitrate/SAC measurement

- Regulating nitrate degradation in denitrification
- Continuous monitoring of nitrate effluent values
- Organic pollution SAC (OS 210)



Parameter section

Dissolved Oxygen

pH/ORP

Conductivity

Turbidity/Suspended Solids

Nitrogen

Carbon: COD/TOC/DOC/BOD/SAC

Phosphate

Sludge level

Measuring Principle Nitrate

The ability of nitrate ions to absorb UV light of certain wavelengths is used for measuring the nitrate. The ultraviolet light from a pulsed photoflash lamp passes through a flow-thru measuring cuvette where it is partially absorbed by the nitrate ions present in the sample flow. The intensity of the attenuated light is measured at a measuring wavelength and at a reference wavelength and evaluated electronically. The 4-beam measuring method used ensures a high degree of long-term stability and absolute accuracy; interfering background influences are efficiently compensated.

SAC measuring principle

Absorption measurement of aqueous sample in UV range. The SAC (spectral absorption coefficient), measured with a wavelength of 254 nm, represents the organic water pollution.

Technical Data ON 210/OS 210	
Measuring Range	NO ₃ -N: 0.1 - 60 mg/l 0 - 4000 mmol/l
	NO ₃ : 0.1 - 250 mg/l 0 - 4000 mmol/l
	SAC: 0.1 - 200m ⁻¹
Resolution (Display)	Nitrate: Range: 0.1 ... 100 mg/l : 0.1 mg/l 100 ... 250 mg/l : 1 mg/l SAC: 0.1 m ⁻¹ (only OS 210)
Accuracy	±2% of the measured value ±0.4 mg/l
Coefficient of variation for method	2%
Response Time	30 s (after alteration in concentration at module input)
Measuring interval	Continuous mode and 5, 10, 15, 20, 25, 30 min intervals selectable, AutoAdapt, Interval-Program
Calibration	Automatic zero balance, works calibration
Sample Flow Rate	0.5 l/hr approx., suspended solids content <50 mg/L
Consumption	Distilled water, 10 l: 130 days with 24 h interval for zero balance Cleaning solution, 1.5 l: 120 days with 24 h cleaning interval
Maintenance Interval	Every 6 months
Guaranty	2 years for defects of quality

Ordering Information

Separate TresCon® analyzer module for nitrate (+ SAC) for extension of an existing TresCon® system (requires 1 measuring place)		Order No.
ON 210	Nitrate	820 007
OS 210	Nitrate + SAC	820 010
TresCon® basic instrument with analysis module ON 210 (nitrate) or OS 210 (nitrate + SAC) (wall mounting, space for 2 further modules)		Order No.
TresCon® N 211	Nitrate	8A-20030
TresCon® S 211	Nitrate + SAC	8A-70030
TresCon® Uno single parameter system nitrate or nitrate + SAC with analysis module ON 210 or OS 210		Order No.
TCU/N211	TresCon® Uno nitrate	820 102
TCU/S211	TresCon® Uno nitrate + SAC	820 107

IP 54

2 Year Guaranty

Accessories and consumables see brochure "Product Details"



TresCon® ON 510

- Continuous background compensation
- Reliable and accurate – 2-beam reference photometer
- Can be used in weakly polluted water without sample preparation

On-line nitrite measurement

- Observation of the nitrification process
- Monitoring nitrite effluent values
- Measurement checks in drinking water treatment
- Monitoring nitrite pollution in natural waters
- Monitoring of critical values in fish farming



Measuring Principle

The measuring principle of the NO₂ analyzer module is based on the azo dye method. A reagent reacts with nitrite to color the sample solution pink. The intensity of the pink color is proportional to the nitrite concentration in the sample and is measured by a double-beam reference photometer. An additional manual correction facility allows the system to be adapted to plant-specific characteristics so that a high degree of measuring accuracy can be achieved even with strongly colored samples.

Technical Data ON 510

Measuring Range	NO ₂ -N: 0.005 - 1.200 mg/l 0.40 - 90 µmol/l NO ₂ : 0.020 - 4.000 mg/l 0.40 - 90 µmol/l
Resolution (Display)	Range: 0.005 ... 1.200 mg/l : 0.001 mg/l 0.020 ... 4.000 mg/l : 0.001 mg/l 0.40 ... 90.00 µmol/l : 0.1 µmol/l
Accuracy	±2% of the measured value ±0.05 mg/l NO ₂ -N
Coefficient of variation for method	1 %
Response Time	<5 min to measured value (after alteration in concentration at module input)
Measuring interval	5, 10, 15, and 20 min intervals selectable, AutoAdapt, Interval-Program
Calibration	Automatic 2-point calibration, time and interval selectable
Background Correction	Continuous background compensation based on new WTW algorithm
Sample input	Approx. 0.06 l/h, solid content <50 mg/l
Consumption	Reagent, 1 l: 20/40/80 days with 5/10/20 min measuring interval Standard B, 1 l: 80 days with 24 h calibration interval Cleaning solution, 1.5 l: 45 days with 24 h cleaning interval
Maintenance Interval	Every 6 months
Guaranty	2 years for defects of quality

Ordering Information

Model		Order No.
ON 510	Separate TresCon® analyzer module for nitrite for extension of an existing TresCon® system (requires 1 measuring place)	820 009
TresCon® N 511	TresCon® basic instrument with analysis module ON 510 for nitrite (wall mounting, space for 2 further modules)	8A-30030
TCU/N511	TresCon® Uno single parameter system nitrite with analysis module ON 510	820 103



Accessories and consumables see brochure "Product Details"



Carbon

Carbon

The main task of a wastewater treatment plant is to reduce the total organic load of wastewater in addition to all the progress made in nitrogen and phosphate elimination. Organic compounds consist mainly of the elements carbon and hydrogen. The cleaning process converts them to carbon dioxide and water while consuming oxygen.

Carbon parameters:

TOC:
A measure for the total organically bound carbon

DOC:
Dissolved organic share of TOC

COD:
Contains all substances that can be solubilized by chemical oxidation. It is at the same time the conventional parameter for the calculation of wastewater charges

BOD:
Contains only the compounds that can be oxidated microbiologically

Carbon parameters

To measure the organic load of water, the parameters TOC, DOC, COD or BOD are used. The differences in these parameters (marginal column) show that these measurements are not identical and that the measured values therefore can not be equal.

Analysis procedures

For an analytical online determination, all these parameters require complex procedures for digestion and the corresponding instrumentation.

SAC

The SAC (spectral absorption coefficient) is a parameter that can be determined more easily. Many organic compounds have characteristic UV absorption spectrums. The intensity of the light attenuation can, therefore, be correlated with the organic load.

This correlation is significant in measuring media with low variations of composition concerning color, solids and their

- Parameter section
- Dissolved Oxygen
- pH/ORP
- Conductivity
- Turbidity/Suspended Solids
- Nitrogen
- Carbon: COD/TOC/DOC/BOD/SAC
- Phosphate
- Sludge level

COD measurement in the laboratory



Individual measurement

=> time-delayed,
suitable for monitoring

In-situ measurement

Using spectrometer sensors



Continuous measurement

=> fast response time,
suitable for control strategies

optical characteristics. Wastewater, however, contains many substances with completely different optical characteristics. For each substance, a different correlation factor concerning the carbon content applies. Measuring at only one wavelength, e.g. at 254 nm for the SAC_{254} , can often show the load only inadequately – especially if the matrix changes.

Spectral Online Sensors

The **CarboVis®** and **NiCaVis®** sensors measure the total spectrum range from ultraviolet to long wave visible light (200-720 nm; UV-VIS sensors) or in the ultraviolet range (200-390 nm; UV sensors). The measured values are determined from the high information content of the spectral data. The calculation is based on methods and characteristics that were achieved from a multitude of measurements and long-time analyses. The user can, therefore, select algorithms that are adapted to the measuring site (inlet, Biological Tank, outlet) having a high correlation with the basic parameter COD.

The spectral procedure has an additional advantage: the turbidity of the test sample, which affects optical measurements, is optimally compensated over a wide wavelength range. Moreover, the spectral measurement provides an optimal compensation of the influence of existing nitrate and nitrite for the COD measurement.

The determined measurement result is displayed directly as **mg/l COD**. A known correlation between this basic parameter COD and one of the related carbon parameters (TOC, DOC or BOD, to be selected) can be set by means of a user-specific calibration. The result is then displayed directly as, e.g. mg/l TOC.

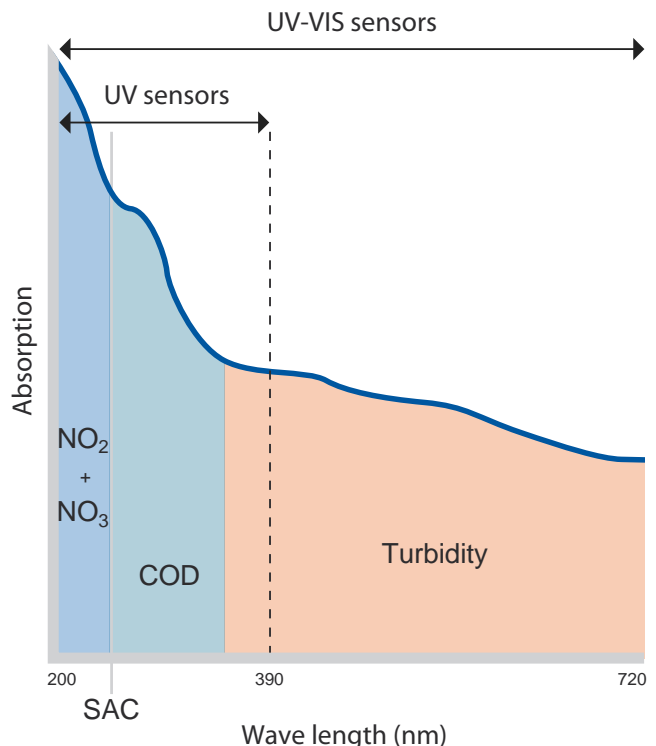

Example spectrum of UV-VIS sensor

Applications

The most important measuring points of wastewater treatment Plants for COD measurements are the inlet and outlet. To determine the incoming load of the plant, a CarboVis® sensor is positioned in the inlet. The load found in the outlet of the plant is low. With a “CarboVis®” installed there (possibly with integrated total suspended solids measurement), the cleaning performance of this plant can be monitored well. The NiCaVis® combination sensor is also suitable for the outlet. It measures the carbon content as well as the nitrate concentration. Or NiCaVis® NI triple sensor, which determines the carbon content, nitrate and nitrite.

Clean measuring windows - a prerequisite for reliable optical measurements

Fouling on the measuring windows can easily simulate high concentrations in COD measurement systems. Once the dirt has settled on the measurement windows, the continued build-up of dirt particles will progress at increasing speed. Especially the use in treatment plants with strong fouling problem from the growth of microorganisms or the deposit of dirt on the measurement windows presents a real challenge to the optical online measurement technology.

The integrated, permanently operating ultrasonic cleaning of the measurement windows, which is integrated in all spectral WTW sensors as a standard very effectively and gently prevents the growth of all types of dirt/fouling from the start. This guarantees a permanently reliable online measurement.

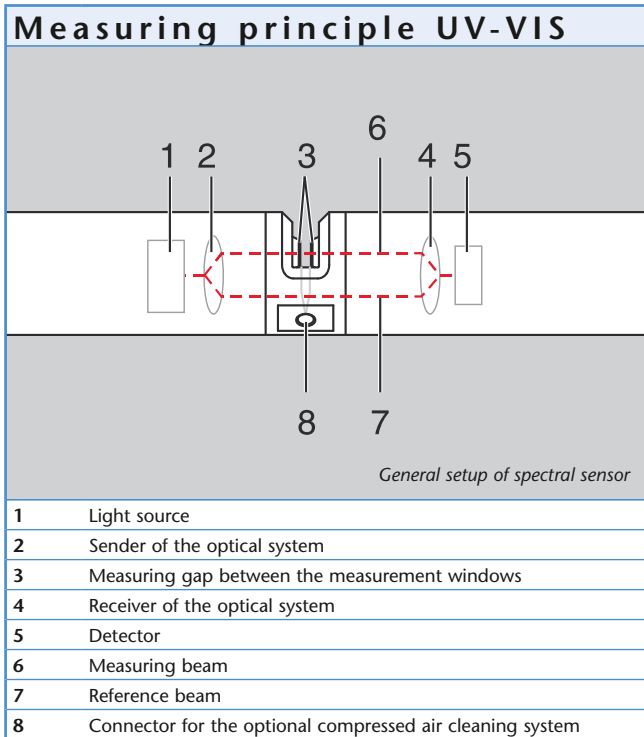

Parameter section

Dissolved Oxygen

pH/ORP

Conductivity

Turbidity/Suspended Solids

Nitrogen

Carbon: COD/TOC/DOC/BOD/SAC

Phosphate

Sludge level

NEW

CarboVis®/NiCaVis®

- High measurement reliability
- Low operating costs
- Simple handling
- Maximum durability

In-situ measurement of COD and suspended solids (optional)

The chemical-free spectral measurement allows a precise determination of the COD and nitrate level.

High measuring reliability

- Wide dynamic range and high measurement accuracy. Automatic adjustment of the number of flashes to the current sample matrix, similar to an exposure measurement in cameras ensure optimal modulations of the detector.

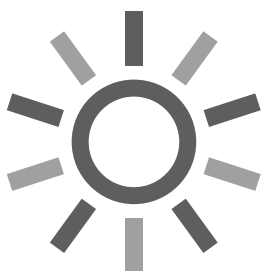

- Excellent measurement repeatability and zero point and long-term stability. 100% symmetrical optics, measurement and reference channel are identical in design, which provides excellent referencing.
- No interference in the COD measurement by nitrate, nitrite and turbidity/suspended solids. Evaluating the entire measured spectrum from 200 to 720 nm provide recognition of interferences; calculate these automatically or apply these for compensation.

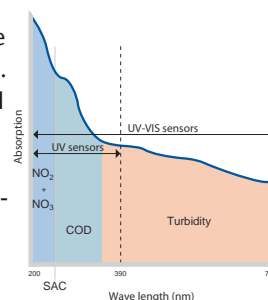
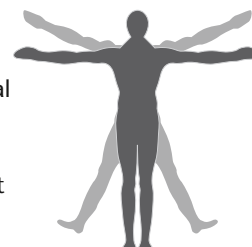

Simple to use

- Due to the built-in ultrasonic cleaning system, a very long maintenance-free operation is possible. Accumulation of dirt and biofilm formation is gently but very effectively prevented in this manner.

Maximum durability

- High-tech materials such as titanium and peek ensure an easy use in almost all media, even corrosive media.



Technical Data CarboVis®/NiCaVis®					
Measuring Principle	Spectral measurement in the UV-VIS range (200 - 720 nm) / UV range of 200 - 390 nm				
	CarboVis® 705 IQ	CarboVis® 701 IQ	NiCaVis® 705 IQ	NiCaVis® 701 IQ NI	NiCaVis® 705 IQ NI
Applications	Municipal wastewater: effluent	Municipal wastewater: inlet, Biological Tank, effluent	Municipal wastewater: effluent	Municipal wastewater: effluent: inlet, Biological Tank, effluent	Municipal wastewater: effluent
Measuring Ranges in Standard Solution (potassium-hydrogenphthalate)	COD: 0.1 ... 800.0 mg/l TOC: 1 ... 500.0 mg/l SAC: 0.1 ... 600.0 1/m	COD: 0.5 ... 4000.0 mg/l TOC: 5 ... 2500.0 mg/l SAC: 0.5 ... 3000.0 1/m	COD: 0.1 ... 800.0 mg/l TOC: 1 ... 500.0 mg/l SAC: 0.1 ... 600.0 1/m NO ₃ -N: 0.01 ... 25.00 mg/l	NO ₂ -N: 0.1 ... 25 mg/l NO ₃ -N: 0.1 ... 100 mg/l COD: 0.5 ... 4000.0 mg/l	NO ₂ -N: 0.01 ... 5 mg/l NO ₃ -N: 0.01 ... 25 mg/l COD: 0.1 ... 800 mg/l
Measuring Ranges TSS (Option)	Inlet: 0 ... 3000 mg/l TSS Effluent: 0.0 ... 900.0 mg/l TSS	Inlet: 0 ... 15 g/l TSS Effluent: 0 ... 4.5 g/l TSS	—	—	—
Materials	Housing: Titanium 3.7035, PEEK Window: Sapphire glass				
Pressure Resistance	≤1 bar				
Ambient Conditions	Operating temperature: 32 °F ... 113 °F (0 °C ... +45 °C) Storage temperature: 14 °F ... 122 °F (-10 °C ... +50 °C)				
Flow Velocity	≤3 m/s				
pH Range	pH 4 ... pH 12				
Salt Content of Medium	<5000 mg/l (Chloride)				
Dimensions	31.57 x 2.36 in. (802 x 59.9 mm, length x diameter)				
Weight	Approx. 8.82 lb (4 kg)				
Guaranty	2 years for defects of quality				

Ordering Information		
UV-VIS sensors CarboVis®	Supplied with multifunctional slide and Shock-Absorption-Rings, without connection cable (SACIQ order separately)	Order No.
CarboVis® 701 IQ	Optical COD/TOC/DOC/BOD or SAC probe, with spectral processing of the UV-VIS range, for in-situ measurement in inlet, BNR part and effluent of municipal wastewater treatment plants, with integrated ultrasonic cleaning.	481 048
CarboVis® 701 IQ TS Double sensor	Optical COD/TOC/DOC/BOD/SAC and TSS probe, with spectral processing of the UV-VIS range, for in-situ measurement in inlet, BNR part and effluent of municipal wastewater treatment plants, with integrated ultrasonic cleaning.	481 049
CarboVis® 705 IQ	Optical COD/TOC/DOC/BOD or SAC probe, with spectral processing of the UV-VIS range, for in-situ measurement in effluent of municipal wastewater treatment plants, with integrated ultrasonic cleaning.	481 050
CarboVis® 705 IQ TS Double sensor	Optical COD/TOC/DOC/BOD/SAC and TSS probe, with spectral processing of the UV-VIS range, for in-situ measurement in effluent of municipal wastewater treatment plants, with integrated ultrasonic cleaning.	481 051
UV-VIS sensors NiCaVis®	Supplied with multifunctional slide and Shock-Absorption-Rings, without connection cable (SACIQ order separately)	Order No.
NiCaVis® 705 IQ Double sensor	Optical nitrate and COD/TOC/DOC/BOD/SAC probe, with spectral processing of the UV-VIS range, for in-situ measurement in effluent of municipal wastewater treatment plants, with integrated ultrasonic cleaning.	481 052
UV sensors NiCaVis®	Supplied with multifunctional slide and Shock-Absorption-Rings, without connection cable (SACIQ order separately)	Order No.
NiCaVis® 701 IQ NI	UV sensor for the measurement of nitrate, nitrite, CODtotal, CODsoluble, TOC, BOD, DOC, SACtotal, SACsoluble and UVT254 in inlet, BNR part and effluent of municipal wastewater treatment plants.	481 054
NiCaVis® 705 IQ NI	UV sensor for the measurement of nitrate, nitrite, CODtotal, CODsoluble, TOC, BOD, DOC, SACtotal, SACsoluble and UVT254 in the effluent of municipal wastewater treatment plants.	481 055
Accessories	for additional compressed air cleaning system (optional)	Order No.
Cleaning Air Box	Cleaning air box with compressor, 230 VAC with air-filter	480 019
MIQ/CHV PLUS	Valve module for automatic cleaning by compressed air; controlled directly via the IQ SENSOR NET Bus	480 018
DIQ/CHV	Valve module for the automatic compressed air cleaning for System 182; accessible by means of an DIQ/S 182 relay	472 007
SET/AP	Compressed air cleaning set: 15 m compressed air tubing incl. fittings, additional modules and components must be ordered separately	481 075

Accessories see page 128.



Phosphate

Phosphate Measurements

Phosphorus compounds – in particular ortho-phosphate PO_4^{3-} – are considered to be the limiting nutrients in most stagnant and flowing waters. An increase in their concentration caused by higher input (wastewater, avulsion etc.) results directly in increasing eutrophication of the water with known effects such as increased growth of algae, oxygen depletion as far as anoxia in the deeper regions, etc.

Measuring Methods

Molybdenum blue method

In an acidic medium, ortho-phosphates bond with ammonium molybdate to form molybdenic phosphoric acid. With the aid of a reducing agent this forms phosphorus molybdenum blue compound. Photometrical measurement of dye intensity can be performed at 880 nm.

Vanadate/molybdate method (yellow method)

In acids, ortho-phosphate ions react with ammonium molybdate and ammonium vanadate to form yellow ammonium phosphoric vanadomolybdate. This can be photometrically analyzed at 380 nm.

Phosphorus Compounds in Water

Phosphorus occurs in 3 compounds in natural waters:

- inorganic, dissolved ortho-phosphate
- dissolved organic phosphorus compounds
- particulate phosphorus (bound in biomass or attached to particles),

which add up to the total of phosphorus content P_{Total} , an important parameter in monitoring wastewater treatment plant effluents.

Measuring Methods and Digestion

There are two methods available for determining phosphate or phosphorus concentrations:

- Molybdenum blue method
- Vanadate/molybdate method (yellow method)

Both techniques are based on the measurement of ortho-phosphate. Digestion of both dissolved organic as well as particulate phosphorus compounds is therefore mandatory for determining the total P content. In addition, an unfiltered sample must be acquired in order to include all solid matters in the digestion process. Digestion is usually performed by heating the sample with peroxodisulfate and sulfuric acid.

Elimination of Phosphates in Wastewater

To meet the required limits of P concentration in the effluent, the modern wastewater treatment facility has two methods available:

- Biological elimination of phosphates “Bio-P”: incorporation of phosphate in microbial biomass (usually in combination with a preliminary anaerobic stage to stimulate luxury consumption of phosphate and intracellular storage as polyphosphate)
- Chemical-physical elimination of phosphates: Chemical precipitation of ortho-phosphates using metallic salts (usually Fe^{3+} or Al^{3+}). The use of ortho-phosphate analyzers for effective control and regulation of precipitations results in considerable savings.

Regulation according to P Concentration

With a continuous monitor PO_4 analyzer, the operator of water treatment plants can realize significant cost savings.

(cf. Application Report PO4 1609 2003 01e)



NEW

On-site analyzer P 700 IQ

In order to also compete in the field of phosphate measurements with cutting-edge technology, WTW has expanded its range of measuring equipment and now offers an ortho-phosphate measurement of the IQ SENSOR NET.

P 700 IQ

- Low reagent consumption
- Wide measuring range
- Automatic calibration
- On-site installation
- Direct connection to the IQ SENSOR NET

IQ
SENSOR NET^{XT}

PO₄



- The benefits at a glance:**
- **On-site installation**
Analyzer can be used outdoor in any weather conditions (option)
 - **Compact design**
Pump for permeate supply is integrated in the analyzer housing (option)
 - **Low Reagent Consumption**
Reduction of cost of ownership
 - **Wide measuring range**
Suitable for universal applications
 - **Automatic calibration**
Reliable results due to automatic calibration function (adjustable)
 - **Direct connection to the IQ SENSOR NET**
Take advantage of the IQ SENSOR NET world: flexibility, modularity, reliability and cost efficient system extension

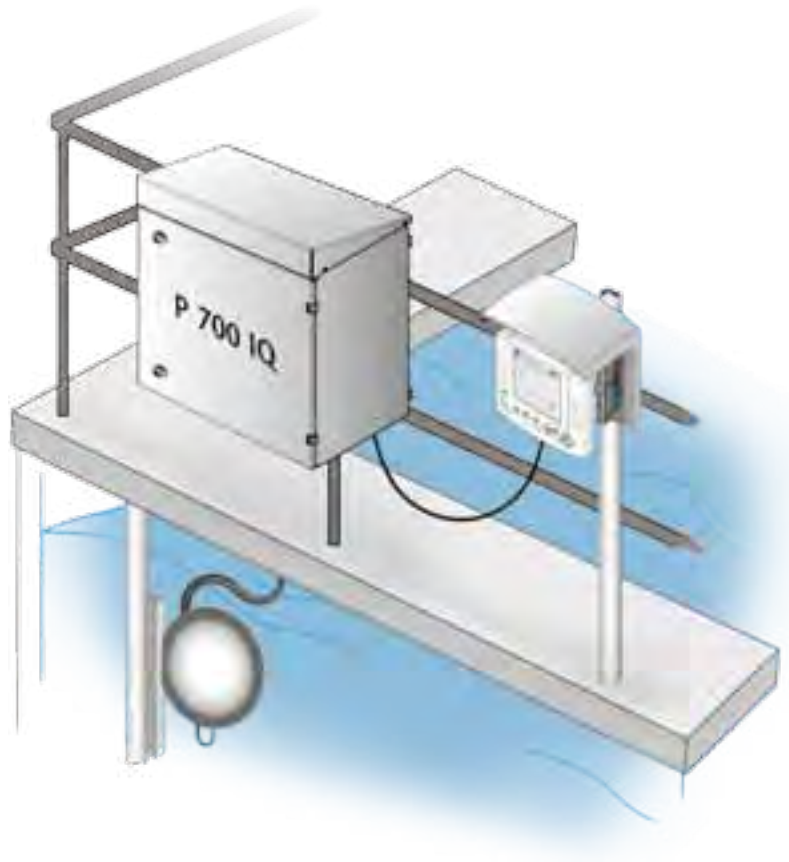

Features of the P 700 IQ

The P 700 IQ can directly be operated at the process tank in an external installation (on-site). Short transporting routes and timely measurement values are therefore guaranteed. The device is well protected against weather effects due to passive insulation and an active temperature control.

Fully automatic calibration function with selectable calibration intervals provides special operating safety (can be deactivated).

The measuring principle is based on the photometric yellow method (molybdate-vanadate), which has been used for years to measure orthophosphate. In addition, the P 700 IQ has been distinguished by its extremely low reagent consumption – a benefit that reduces operating costs significantly.

Based on the large measuring range, the P 700 IQ can be used universally. Switching between the measuring ranges can be accomplished at any time at no additional cost.

As easy to use as an IQ sensor

The P 700 IQ is directly connected to the IQ SENSOR NET via the SNCIQ cable (System 2020 XT). The power is supplied to the analyzer itself.

All settings are made via the terminal/controller, as all other IQ sensors.

The user has all the advantages of the IQ SENSOR NET world available with the P 700 IQ – an unbeatable advantage in terms of flexibility, modularity and security.

The integration of the analyzer into existing IQ systems and their expansion to include additional measured variables are simple and designed to be user-friendly.

Parameter section

Dissolved Oxygen

pH/ORP

Conductivity

Turbidity/Suspended Solids

Nitrogen

Carbon: COD/TOC/DOC/BOD/SAC

Phosphate

Sludge level

IQ SENSOR NET

Information for the
IQ SENSOR NET, see
page 74



Technical Data P 700 IQ

Measuring method	Molybdate-vanadate
Measuring range	Measuring range A: 0.05 ... 15.00 mg/l PO ₄ -P Measuring range B: 1 ... 50 mg/l PO ₄ -P
Resolution	Measuring range A: 0.05 mg/l PO ₄ -P Measuring range B: 1 mg/l PO ₄ -P
Accuracy	Measuring range A: ±2%, ±0.05 mg/l Measuring range B: ±2%, ±1 mg/l
Response time t ₉₀	<5 min
Detection limit	Measuring range A: 0.05 mg/l PO ₄ -P Measuring range B: 1 mg/l PO ₄ -P
pH range	5 ... 9
Sample temperature	4 ... 45 °C (39.2 ... 113 °F)
Measuring interval	<5 min (adjustable)
Operating temperature	-4 ... 104 °F (-20 ... 40 °C)
Storage temperature	-4 ... 122 °F (-20 ... 50 °C)
Reagent consumption	2500 ml container for 8 months at a measuring range (A) at a 10 min measurement interval 2500 ml container for 4 months at a measuring range (B) at a 10 min measurement interval
Cleaning Solution	1000 ml for 4 months with daily cleaning
Conformity	CE
Equipment safety	EN 61010-1; UL 3111-1, CAN/CSA C22.2 No. 1010.1)
Climate control	Heater and fan
Power supply	115/230 VAC
Weight	~66 lb (~30 kg; without reagents)
Dimensions	~26.69 x 30.71 x 15.55 in. (~678 x 780 x 395 mm)
Outputs	Relays, analog outputs, interfaces via System 2020 XT
Calibration	Manual or automatic (adjustable)

Ordering Information

P 700 IQ		Order. No.
P 700 IQ-PO230	Orthophosphate analyzer P 700 IQ for the IQ SENSOR NET with integrated pump unit for filtration, Outdoor, 230V	8P-111
P 700 IQ-PI230	Orthophosphate analyzer P 700 IQ for the IQ SENSOR NET with integrated pump unit for filtration, Indoor, 230V	8P-110
P 700 IQ-O230	Orthophosphate analyzer P 700 IQ for the IQ SENSOR NET, Outdoor, 230V	8P-101
P 700 IQ-I230	Orthophosphate analyzer P 700 IQ for the IQ SENSOR NET, Indoor, 230V	8P-100



115V versions on request

Filtration P 700 IQ

- Compact design (permeate pump can be integrated in P 700 IQ housing)
- Easy and quick to clean
- Long operating periods between two cleanings
- High operational safety



The sample preparation is specifically designed for the operation of the analyzers that work with very small sample amounts. In order to keep the dead times as low as possible at the relatively low level of permeate, which are needed for the analysis, the permeate is continuously withdrawn by using a vacuum and delivered to the analyzer.

The filter module is immersed into the tank via a bracket mounted on the tank's edge and supplies the analyzer with permeate via a suction line. Maintenance takes place directly at the tank's edge: The technically sophisticated rail system allows the user to lift the filter without any effort from the tank and clean it, which saves time and is easy to maintain.

A special feature of the sample filtration: The pump unit is already installed in the housing of the P 700 IQ (option). This combination is easy to install and cost effective.

Technical Data of the P 700 IQ Filtration

Membrane area	155.00 in ² (1.000 cm ²)
Maximum operating temperature:	113 °F (45 °C)
Maximum operating overpressure (Raw water to permeate side):	2.0 bar at 68 °F (20 °C)
Operating under pressure (permeate side):	approx. 0.5 bar at 68 °F (20 °C)
Materials:	Housing: PVC Seals: NBR Screws: Stainless steel

Ordering Information

Model	Description	Order. No.
FM	Filter membrane module including mounted diaphragm	821 987
M 1.5	Tank bracket (rail) 1.5 m, chain, bracket	821 986
M-EXT 1.5	Extension tank bracket 1.5 m, chain, bracket	821 985
FM-Adapter	Adapter for the horizontal assembly of the filter membrane module	821 983
SL 230-5	Suction incl skid/ heater 230 VAC, 5 m	821 982
SL 230-10	Suction incl skid/ heater 230 VAC, 10.94 yd (10 m)	821 980
SL 5	Suction line including skids, unheated, 5m	821 978
SL 10	Suction line including skids, unheated, 10.94 yd (10 m)	821 977
RL 230-2	Heated Permeate return line, 230 VAC, 2 m	821 976
RL 2	Permeate return line unheated, 2 m	821 974
Filter	Membrane insert PMM (1 set=2 pieces)	821 972



115V versions on request

Parameter section

Dissolved Oxygen

pH/ORP

Conductivity

Turbidity/Suspended Solids

Nitrogen

Carbon: COD/TOC/DOC/BOD/SAC

Phosphate

Sludge level

TresCon® OP 210

- Yellow method
- Continuous background compensation
- Continuous/Discontinuous operation selectable

Online orthophosphate measurement

- Control or feedback control of chemical phosphate precipitation, e.g. precipitating agent addition with simultaneous precipitation
- Monitoring biological phosphate elimination
- Measuring the phosphate pollution in natural waters
- Monitoring the phosphate concentration in the drinking water



Measuring Principle

The PO₄ module uses the vanadate/molybdate method (yellow method) for determining the orthophosphate content. A reagent reacts with phosphate in the sample to color the sample solution yellow. The intensity of this color is recorded photometrically and evaluated as a measure of the phosphate content.

Technical Data OP 210

Measuring Ranges	PO ₄ -P	PO ₄
	Measuring range 1: 0.05 - 3.00 mg/l; 1.5 - 100 µmol/l	0.15 - 9.00 mg/l; 1.5 - 100 µmol/l
	Measuring range 2: 0.1 - 10.0 mg/l; 3 - 320 µmol/l	0.3 - 30.0 mg/l; 3 - 320 µmol/l
	Measuring range 3: 0.1 - 25.0 mg/l; 3 - 800 µmol/l	0.3 - 80.0 mg/l; 3 - 800 µmol/l
Resolution (Display)	Measuring range 1: 0.01 mg/l or µmol/l	
	Measuring range 2: 0.1 mg/l or µmol/l	
	Measuring range 3: 0.1 mg/l or µmol/l	
Accuracy	±2% of the measured value ±0.01 mg/l PO ₄ -P (Measuring range 1) ±2% of the measured value ±0.1 mg/l PO ₄ -P (Measuring range 2 and 3)	
Coefficient of Variation for Method	2% (for all measuring ranges)	
Response Time	<4 min to measured value (after alteration in concentration at module input)	
Measuring Interval	Quasi-continuous measurement, 5, 10, 15, 20, 25 or 30 min settings	
Calibration	Automatic 2-point calibration (time and interval selectable)	
Background Correction	Continuous background compensation based on new WTW algorithm	
Sample Input	Approx. 0.06 l/h, solid content <50 mg/l (e.g. sewage treatment plant effluent)	
Consumption	Reagent, 10 l:	60/155/310/465 days with cont./10/20/30 min measuring intervals
	Standard B 1.5 l:	90 days with 24 h calibration interval
	Cleaning solution, 1.5 l:	45 days with 24 h cleaning interval
Maintenance Interval	Every 6 months	
Guaranty	2 years for defects of quality	

Ordering Information

Separate TresCon® analyzer module for Orthophosphate for extension of an existing TresCon® system (requires 1 measuring place)		Order. No.
OP 210/ MB 1	Module for Orthophosphate: Measuring range 1	820 004
OP 210/ MB 2	Module for Orthophosphate: Measuring range 2	820 005
OP 210/ MB 3	Module for Orthophosphate: Measuring range 3	820 006
TresCon®-basic instrument with analysis module OP 210 for ortho-phosphate (wall mounting, space for 2 further modules)		Order. No.
TresCon® P 211/MB1	Orthophosphate, Measuring range 1	8A-40030
TresCon® P 211/MB2	Orthophosphate, Measuring range 2	8A-50030
TresCon® P 211/MB3	Orthophosphate, Measuring range 3	8A-60030
TresCon® Uno single parameter system ortho-phosphate with analysis module OP 210		Order. No.
TCU/P211-MB1	TresCon® Uno for Orthophosphate: Measuring range 1	820 104
TCU/P211-MB2	TresCon® Uno for Orthophosphate: Measuring range 2	820 105
TCU/P211-MB3	TresCon® Uno for Orthophosphate: Measuring range 3	820 106



Accessories and Consumables see brochure "Product Details"

TresCon® OP 510

- 2-point calibration – high degree of accuracy
- Automatic Monitoring
- “Blue” method



Online P_{Total} measurement

- Monitoring the effluent from wastewater treatment plant for P_{Total}
- Monitoring phosphorus pollution in natural waters

Measuring Principle

The P_{Total} module consists of two units: in the first unit (digestion unit) the sample undergoes a chemical-thermal digestion; in the second unit the total phosphorus content is determined.

During the digestion all the phosphorus compounds contained in the sample are converted to orthophosphate; this can be determined photometrically. The phosphorus compounds are oxidized by peroxodisulfate under acidic conditions.

This process is accelerated by overpressure and an increased temperature so that very short digestion times are achieved.

The subsequent analysis is by the molybdenum blue method. The sample is mixed with a molybdate reagent which reacts with phosphate via an intermediate chemical step to form a blue coloration. The intensity of this coloration is a measure of the original concentration of the phosphate ions. It is measured photometrically and evaluated.

Technical Data OP 510	
Measuring Ranges	P _{Total} : 0.01 ... 3.00/6.00*; 0.3 ... 100/200*
Resolution (Display)	Range: 0.01 ... 3.00 mg/l : 0.01 mg/l 0.30 ... 100 µmol/l : 0.1 µmol/l
Accuracy	± 3 % of the measured value ± 0.05 mg/l P _{Total}
Measuring Principle	Photometric reference beam method after digestion
Measuring Method	Molybdenum blue methode
Coefficient of Variation for Method	1.5 %
Measuring Interval	10, 15, 20, 25, 30 or 60 min can be set (DIN EN measurement with 30 min digestion at approx. 248 °F/120 °C)
Calibration	Fully automatic 2-point calibration
Consumption	Reagents A, B, C, D: 10/15/20/30/60 days with 10/15/20/30/60 min measuring intervals Standard, 1.5 l: 70 days with 24 h calibration interval Cleaning solution, 1.5 l: 60 days with 24 h cleaning interval
Maintenance Interval	Every 3 months
Guaranty	2 years for defects of quality

Ordering Information

		Order. No.
OP 510	Separate TresCon® analyzer module for total phosphorus for extension of an existing TresCon® system (requires 2 TresCon® measuring locations)	820 011
TresCon® P 511	TresCon®-basic instrument with analysis module OP 510 for total phosphorus (wall mounting, space for 1 further module)	8A-8X030

Accessories and Consumables see brochure “Product Details”
 Homogenizer available on demand (see brochure “Product Details”)
 * by continuous sample dilution in a 1:1 ratio

Parameter section

Dissolved Oxygen

pH/ORP

Conductivity

Turbidity/Suspended Solids

Nitrogen

Carbon: COD/TOC/DOC/BOD/SAC

Phosphate

Sludge level



Online Sludge Level Measurement

Measuring . Monitoring . Controlling

The sludge level is the boundary of settled sludge to the projecting turbidity or clear water, wherein the location of the sludge level is specified at the distance to the water surface (sludge level depth), or as distance from the tank bottom (sludge level).

The sludge level plays primarily a role in the area of wastewater treatment, water treatment and also in the process analysis. Accurate knowledge of the location of the sludge is especially important in process stages of phase separation. The sensor can be used in clear, turbid and heavily polluted liquids with a high solids content. The newest product, the digital sludge level sensor IFL 700 IQ combines advanced technology with user-related benefits.

Online sludge level measurement

- Municipal and industrial wastewater
- Water treatment
- Industrial process media

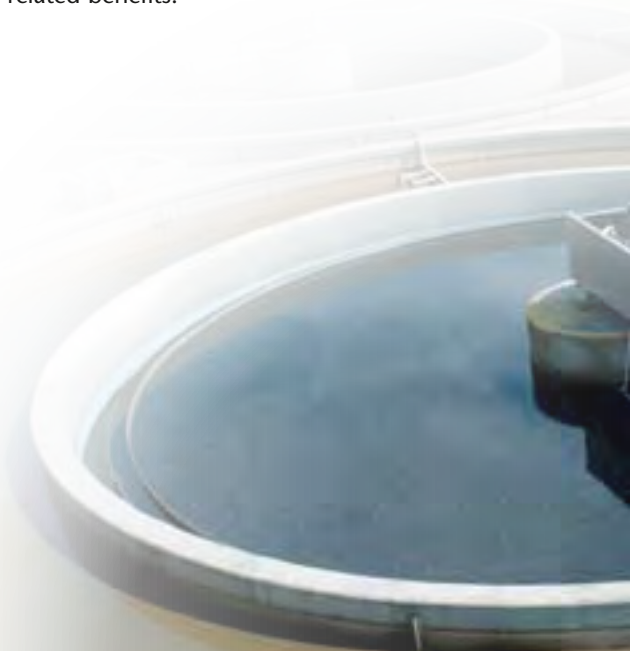

NEW

Sludge level

Efficient sludge control and monitoring of treatment plants

Sludge level measurement is a very common application in wastewater treatment:

Typical measurement locations in a wastewater treatment plant are pre-sedimentation, thickener and post-sedimentation. The process tanks of the pre-sedimentation and post-sedimentation specifically can be designed very differently. Generally circular and rectangular, elongated tanks can be found. The sludge settles in these tanks. Skimmers ensure that the sludge collects in hoppers until it is ultimately removed. The sludge level measurement primarily supports

- The optimization / control of the (primary) sludge extraction
- The management of the return sludge
- Monitoring of the settling behavior
- The prevention of sludge loss

The latter can sometimes lead to exceeding limits in the drainage. A costly scenario, which must be prevented.

Reliable ultrasonic measuring principle

The IFL 700 IQ is based on the ultrasonic measuring principle, wherein the determination of the sludge level over the duration of the echo is determined. Unlike optical sludge level measurement systems, this continuous measurement principle offers important benefits that are shown by lower capital and operating costs, less maintenance and higher data availability.



Parameter section

Dissolved Oxygen

pH/ORP

Conductivity

Turbidity/
Suspended Solids

Nitrogen

Carbon: COD/TOC/
DOC/BOD/SAC

Phosphate

Sludge level

The non-contact stripper keeps the ultrasonic generator free from air bubbles and outgrowth



IFL 700 IQ

- Intelligent signal processing
- Ready-to-go
- Detailed display of echo profile
- Maintenance-free cleaning system



Intelligent signal processing

Measurements are frequently affected by additional interference reflections, the origins of which stem from fixed or mobile processing structures and process activities.

Constant interference reflections can be quite easily taken into account by limiting the measurement range as required. Temporary events, however, such as moving skimmers can be blocked out by using conventional methods, such as signal filtering or smoothing. At this point, WTW is setting new benchmarks in the signal processing with the IFL 700 IQ. The sensor has a special pattern recognition and can thus distinguish between the sludge level and unwanted signals. Using the automatic analysis and self-learning function, the undesired sequences can then be faded out automatically during the measurement mode. As a result, reliable measurements are always available to the user.

Ready-to-go

The requirements for the settings for the normal operation are minimal. The system provides the first measurement results after entry of the tank's depth and the immersion depth of the sensor. For difficult applications, additional optional settings can be used that support purposeful the user in his application.

Detailed display of echo profile for visualization

The echo profile on the display contains detailed information on the complete water column below the sensor down to the ground. Settings of the sensor can be made even more easily.

Maintenance-free cleaning system

The IFL 700 IQ has a cleaning system of high quality materials such as titanium (shaft, sealed several times) and Grivory (scraper). Because of the technical design, this system is maintenance free. An annual replacement of seals or the scraper is not required. The cleaning cycle can be set individually in the system. The necessary cleaning frequency is automatically adjusted by the sensor.

For the operation without air bubbles or contamination, the version without a scraper is recommended (IFL 701 IQ).

Display of an echo profile



Accessories

Special equipment for sludge level sensors IFL 700/701 IQ enables the smooth operation of the sensors in the presence of moving surface scrapers, which are often encountered in rectangular sedimentation tanks. The folding or deflector fittings IFL D provide the sludge level sensor with optimum protection and allows the passing scrapers to pass without effort. With the railing assembly IFL RM (can be combined with IFL-D), the sensor can also be placed over the settling hoppers at a greater distance from the edge of the tank.



*Application of the folding fitting IFL D in conjunction with the railing installation IFL RM for moving surface scrapers.
View: sensor in maintenance position (lockable)*

Technical Data IFL 700 IQ	
Measuring method	Ultrasonic echo measurement
Measuring range	0,4 m – 15 m
Resolution	0,01 m
Accuracy	0,1 m
Signal filters	Yes
Flow speed	Max. 4 m/s
Physical dimensions	Length 442 mm; max. diameter 105 mm
Weight	Approx. 3.6 kg
Immersion depth	min. 5 cm; max. 3 m
Protection class	Sensor with SACIQ cable connected: IP 68; 0.3 bar
Pressure resistance	The sensor with connected SACIQ cable complies with the requirements of article 3(3), 97/23/EU guideline.
Permitted pH range of medium	4 ... 12
Permitted temperature range	Medium: >0 ° ... +50 °C, Storage and transport: -5° ... +50°C
Materials	Shaft and baseplate: stainless steel 1.4571 Plug head and transition unit: POM Ultrasound unit: PVC-C Cleaning system: Grade 2 Titanium (shaft), Grivory
Equipment safety, Standards	EN 61010-1; UL 61010-1; CAN/CSA C22.2#61010-1
Electric data	Nominal voltage 24 VDC, provided via the IQ SENSOR NET system
Power consumption	5.5 W, operating with MIQ / Blue PS: 3.0W; without a purification system (P 701 IQ): 3.0 W
Certifications	CE, cETL, ETL
Usable System	IQ SENSOR NET System 2020 XT

Ordering Information		Order No.
IFL 700 IQ	Digital ultrasonic sludge level sensor with automatic cleaning system	481 200
IFL 701 IQ	Digital ultrasonic sludge level sensor	481 201
Accessories		Order No.
IFL-D	Folding or deflector fitting for sludge level sensors IFL 700/701 IQ when used with surface scrapers	481 205
IFL-RM	Railing assembly for sludge level sensors IFL 700/701	481 207



Further Accessories see brochure "Product Details"



IQ SENSOR NET

Flexibility through digital technology – The IQ SENSOR NET from WTW



IQ SENSOR NET

- **One** system for **all** parameters
- Any sensor combination possible
- Up to **20** sensors may be connected
- Simple extension of system at any time
- Simple installation using two-wire technology
- Digital signal transmission
- Integrated lightning protection

With the modular IQ SENSOR NET, WTW has set standards in the field of continuous on-line measurement. Meanwhile, WTW can look back on a more than 10-year success history with thousands of systems and sensors sold. The development of the system has progressed steadily. The list of available parameter measured and the technologies for communication continue to grow. Based on instrument and sensor technology that has been field-proven many times over, IQ SENSOR NET offers an impressive level of performance and flexibility that is unique in this form.

The system can be optimally adapted to any conceivable measurement task, even under special on-site conditions. The IQ SENSOR NET communication system allows the easy integration of multiple measurement locations. This results in a significant reduction in costs while maintaining full functionality.

IQ SENSOR NET System Philosophy

 General Description
of Meters

IQ SENSOR NET

Monitors

Analyzer

 Sample
Preparation

Samplers

Accessories

IQ SENSOR NET – the multi-parameter measuring system

The System 2020 XT is the flexible solution for today and for the future. It's fully modular design "keeps on growing" to keep pace with your growing demand. This flexibility makes the system very appealing also for small, medium, and larger sewage plants. Any conceivable application can be managed including discharge measuring with the parameters turbidity, pH, conductivity and temperature, furthermore the control of nitrification/denitrification and complete sewage plant analytics can be supported by one single system. All this at a low investment cost and highly economical operation – with an easy to handle system.

Any sensor combination possible

The parameter-specific sensors are equipped with a standard interface for communication with central components. Thus, different types of sensors or parameters can easily be connected to the system. The user can freely select parameters and is only restricted by the maximum number of sensors. Thus, application-specific tasks such as inlet or outlet measurement in wastewater treatment plants or simultaneous measurement in several aeration basins can be easily and economically accomplished using a single system.

Up to 20 sensors may be connected

WTW offers IQ sensors for more than 15 different parameters, including new sensors for carbon parameters, nitrate, nitrite that feature a unique cleaning system, and for sludge level measurement. Numerous special sensors designed for specific applications are available for each type of parameter. WTW has available a total of 31 different IQ sensors that can be combined as required. When a sensor is connected to the IQ SENSOR NET, it is recognized automatically and the measured value is displayed immediately. The software is designed in such a way that future parameters can readily be integrated into the existing system. With this intelligent structure, the system can easily be extended or modified to incorporate up to 20 sensors.

Because the calibration data are stored in the sensor, the calibration of IQ sensors can be processed in the laboratory.



Consistently digital and modular

Functional units, such as power supply units, outputs, relays, etc., that were originally incorporated in a conventional monitor, have now been modularized – at both the functional and mechanical levels. Communication between individual components and between sensors is digital.

Digital transmission technology now allows transmission over large distances between the separate system components. Consequently, these components can be placed at almost any location within the system.

The connection is a shielded 2-wire cable that not only transports digital information but also provides the low-voltage power supply to the individual components. With these features the system is able to meet such requirements as

- **a high degree of flexibility in positioning equipment**
(measurement locations can be installed at great distances)
- **local orientation of functionality**
(modules are installed where the functionality is required) and
- **simple installation and system extension**



Extremely flexible and economical

The fact that sensors and system units can be placed at almost any desired location in the wastewater treatment plant, coupled with a simple and secure connection technique, result in the remarkable flexibility of the IQ SENSOR NET. Moreover, the IQ SENSOR NET is highly cost efficient, a direct consequence of the intelligent technology it incorporates:

- A decrease in costs as the number of measurement locations rises, since each additional parameter requires only one additional sensor
- Point-to-point cable connections between individual measurement locations is not required – resulting in considerable savings in cable and installation costs
- The system can be simply and economically extended at any time



Features and functions

of the IQ SENSOR NET system

Power supply and communication in the IQ SENSOR NET

Both power and communications within the system are transmitted via a special shielded two-wire cable referred to as the SNCIQ SENSOR NET cable. The conductors are color-coded to assist in correct connection. Should polarity be reversed accidentally, correct function of the system is fully guaranteed. Because the supply voltage within the system is approx. 24 VDC, there is no risk of coming into contact with dangerously high voltages.

Digital signal transmission

The complete system communication is digital. This ensures high measurement accuracy even with large distances between system components. Digital signal transmission is immune to external EMC interferences.

Integrated lightning protection / high EMC immunity

All IQ SENSOR NET components offer integrated lightning protection in proven WTW quality as a standard feature. This eliminates the need for additional external protective systems. The high EMC immunity of each of the individual components contributes to the maximum operating safety and high availability of the system.

Extension of system components

When the IQ SENSOR NET is extended, the new components are automatically recognized and integrated immediately.

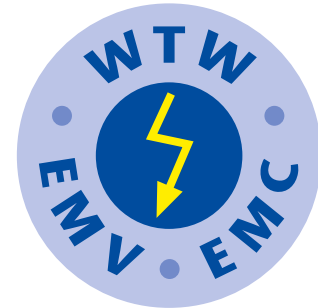
 General Description
of Meters

IQ SENSOR NET

Monitors

Analyzer

 Sample
Preparation

Samplers

Accessories

Exchanging sensors

Sensors can be exchanged during operation without having to shut down the system. All settings from the old sensor can easily be taken over into the new sensor.

Allocation of inputs and outputs as required

Each input component of the system (sensor) can be allocated to any output (mA/relay). Multiple allocations are possible.

Error diagnosis

The system status and all events that occur are recorded in an internal LogBook. The display provides the user with detailed information regarding error diagnosis and troubleshooting.

Mounting

IQ sensors can be installed directly in open channels or basins using field-proven accessories. Various flow-thru vessels are available. Special mounting kits are provided for mounting modules in panels and on top hat rails, walls and handrails. The new SSH/IQ sun shield can be used in combination with all current WTW mounting stands for installation in field.



Features and functions

of the modules



Mechanical docking of a terminal

A Terminal TC 2020 XT can be easily connected to each module. The electrical contact for the power supply and data communication is made simultaneously with the mechanical connection.

Stack mounting of modules

Up to three modules can be mechanically connected to form a stack. Simultaneous mechanical and electrical connection to data and power transmission. The individual modules of the stack can be accessed at any time without dismantling the stack by simply undoing two lateral screws.

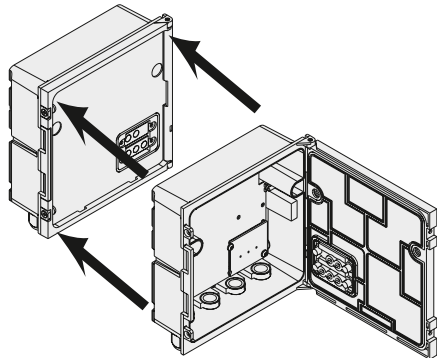

Distributed mounting of modules

All modules can be installed anywhere in the system, both individually and in stacks. When not stacked, system components are connected via the 2-wire shielded SNCIQ SENSOR NET cable. Each Sensor Net connection of a system component can be used to extend the IQ SENSOR NET cable. Furthermore, IQ sensors can also be connected directly to the Sensor Net terminals.

Terminator function of the modules

Each module is equipped with a terminator function. This function is a terminating resistor that can be switched on and off as required. This is important whenever a module is located at the end position in the Sensor Net.

Local identity function

The local ID function is integrated in each module in the form of a memory component. The memory can be used to store relevant information when configuring the system such as location and designation of the measurement location and the sensors connected there. When connecting a terminal, this information is output and facilitates rapid localization of sensors for calibration purposes.

Diagnosis via LEDs

Each module is provided with two LEDs (yellow/red) for diagnostic purposes. They are located on the side of the module and are clearly visible at all times. They indicate whether the respective module is operational (power supply/ data communication).



IQ SENSOR NET system technology

The IQ SENSOR NET construction kit

The IQ SENSOR NET system consists of a variable number of system components with different functions.

The individual components and their primary functions are

Controller and terminal	Controller	Controls all communication within the system
	Terminal	Display of measurements, operation and system configuration (“Human Machine Interface”)
Modules	Power supply modules	Power supply for system components
	Combined output module	Transmission of measured data or message/alarm functions (mA/relays)
	Branching modules	System branching and sensor connection
Sensors	IQ sensors and connection modules for passive sensors	Measurement of parameters
Cables	Sensor connection cable	Cables for connecting sensors to modules
	Module connection cable	Cables for connecting modules to remote measuring points
	Module connection cable, ground installation	Cables for connecting modules to remote measuring points, specifically for the ground installation.



Simple installation at the process tank (on-site)

IQ Systems

Sensor network or single measuring stations – an easy choice ...

The planning begins with a basic decision between 2 systems

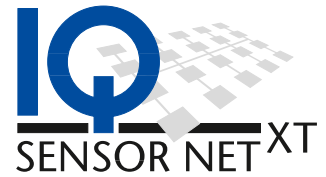

**Sensor network
System 2020 XT
(up to 20 sensors)**



**Single point
measuring system
System 182
(1 to 4 sensors)**



- Central (network) and decentralized system for up to 20 sensors possible – extendable by up to 3 terminal / controller units for flexible installation within the network.
- Digital and / or analog outputs, can be combined and extended by modules and integrated within the network.

- Decentralized system for 1 to 4 sensors with integrated terminal.
- Models with integrated analog or digital outputs (i.e. RS-485/ field bus connections PROFIBUS or MODBUS) available

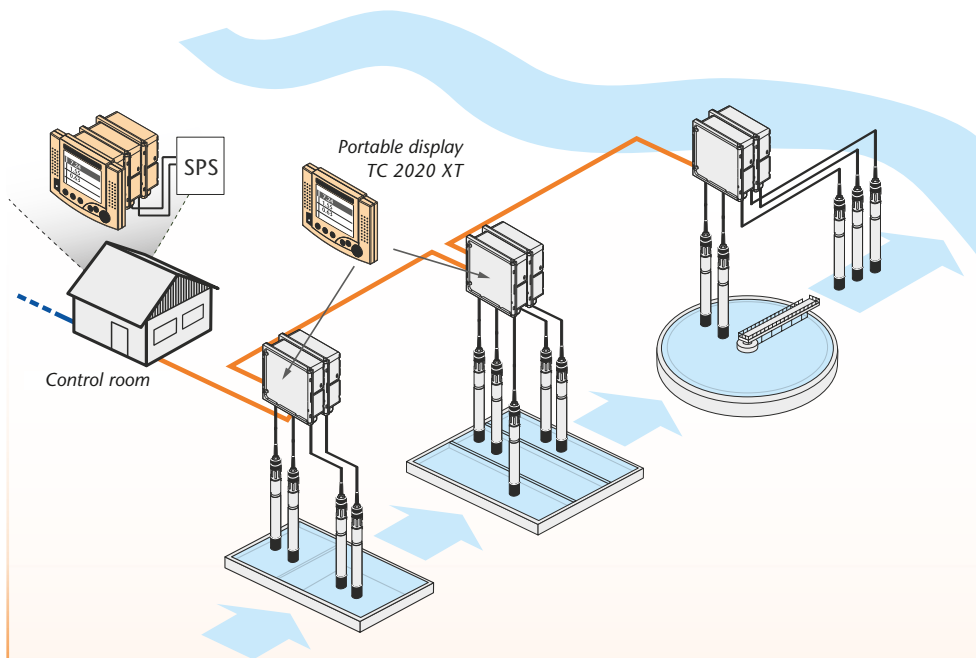

Example for a central network with system 2020 XT using 14 sensors

see page 82

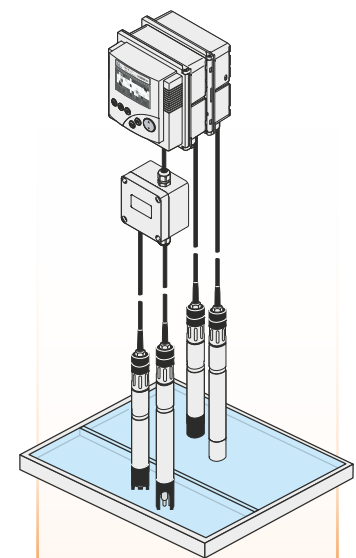

Example for a single point measuring system using 4 sensors

see page 94

IQ Sensors

One connection for all IQ sensors – via the universal SACIQ sensor cable

The standard version of high grade stainless steel is suitable for process and industry. All media contacting components of the seawater versions are made of titanium and plastic and are therefore extremely resistant to corrosion.

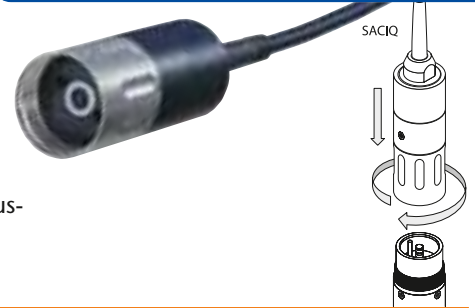

<p>O₂</p>	<p>pH</p>	<p>Cond</p>	
<p>Dissolved Oxygen page 8–16</p>	<p>pH / ORP page 19–22</p>	<p>Conductivity page 28–31</p>	
<p>Turb TSS</p>	<p>NH₄ NO₃</p>	<p>TSS NO₂ NO₃ SAC</p>	<p>CSB TOC IFL</p>
<p>Turbidity and suspended solids page 34–37</p>	<p>Ammonium and nitrate page 44–50</p>	<p>Nitrite, Nitrate, COD / TOC / DOC / BSB / SAC page 51 & 60/61</p>	<p>Sludge level page 70</p>

General Description of Meters

IQ SENSOR NET

Monitors

Analyzer

Sample Preparation

Samplers

Accessories

The System 2020 XT –

the modular solution for today and for the future

Do you plan a sensor network with multiple sensors or to upgrade your installation step by step?

The System 2020 XT represents the perfect solution for these challenges.

Important system features:

- Up to **20** digital IQ sensors at user's choice may be connected
- Easy **system expansion**, no previous knowledge required
- Centralized power supply using a wide range power supply (100 – 240 VAC) or 24 V variant
- A nearly unlimited number of relays and analog outputs (0/4-20 mA) may be selected
- Digital outputs **PROFIBUS DP** or **MODBUS RTU**
- Optional modem connection via **analog** or **GSM modem**
- **Wireless connection** via radio transmission
- **Easy integration** of existing measuring points by mA inputs

Digital communication with the IQ Net

MIQ/2-PR modul IQ
with PROFIBUS-DP
connection

MIQ/2-MOD modul IQ
with MODBUS RTU/RS 485
connection

MIQ/Blue PS
for wireless connection
and linking withing the
IQ SENSOR NET System

Additional IQ SENSOR NET
islands possible.

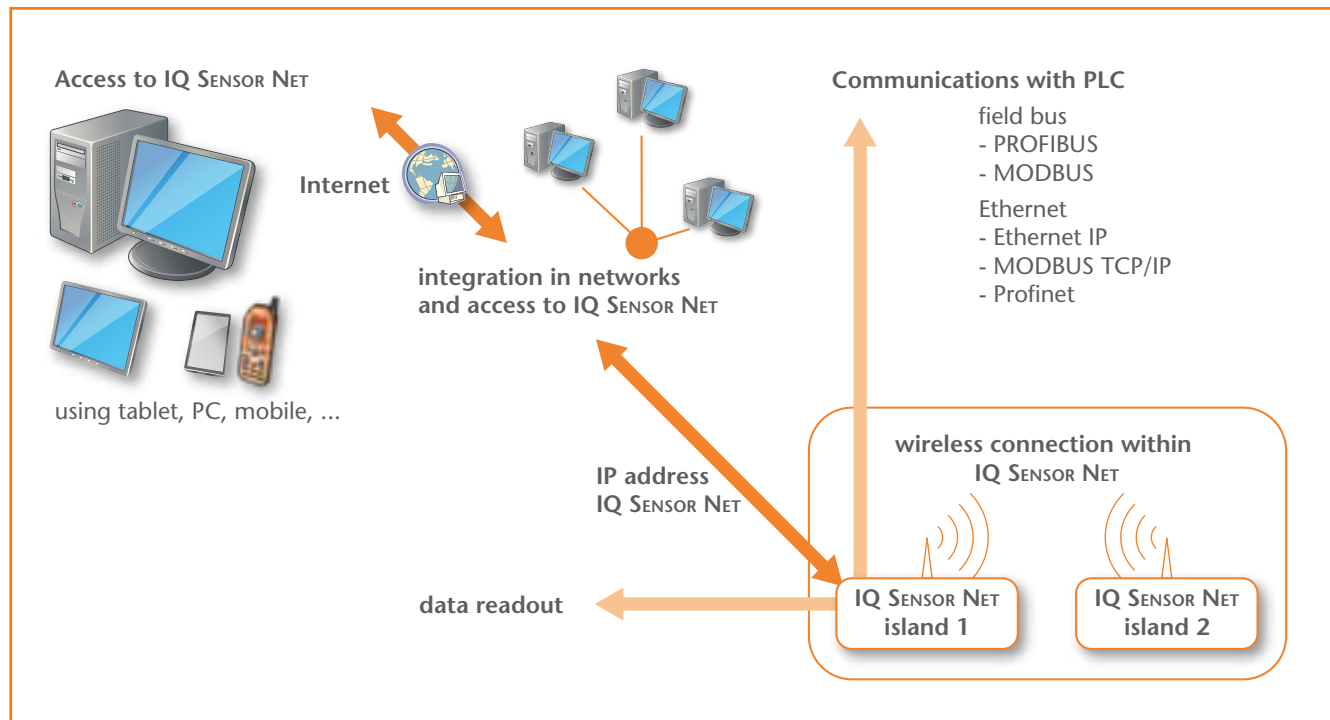

System architecture MIQ/TC 2020XT

The terminal/controller MIQ/TC 2020 XT can be operated as either controller (permanently installed with the system) as also as mobile terminal. This function can easily be configured with the software by each user. The status LED indicates the selected function and informs about any possible incidents.

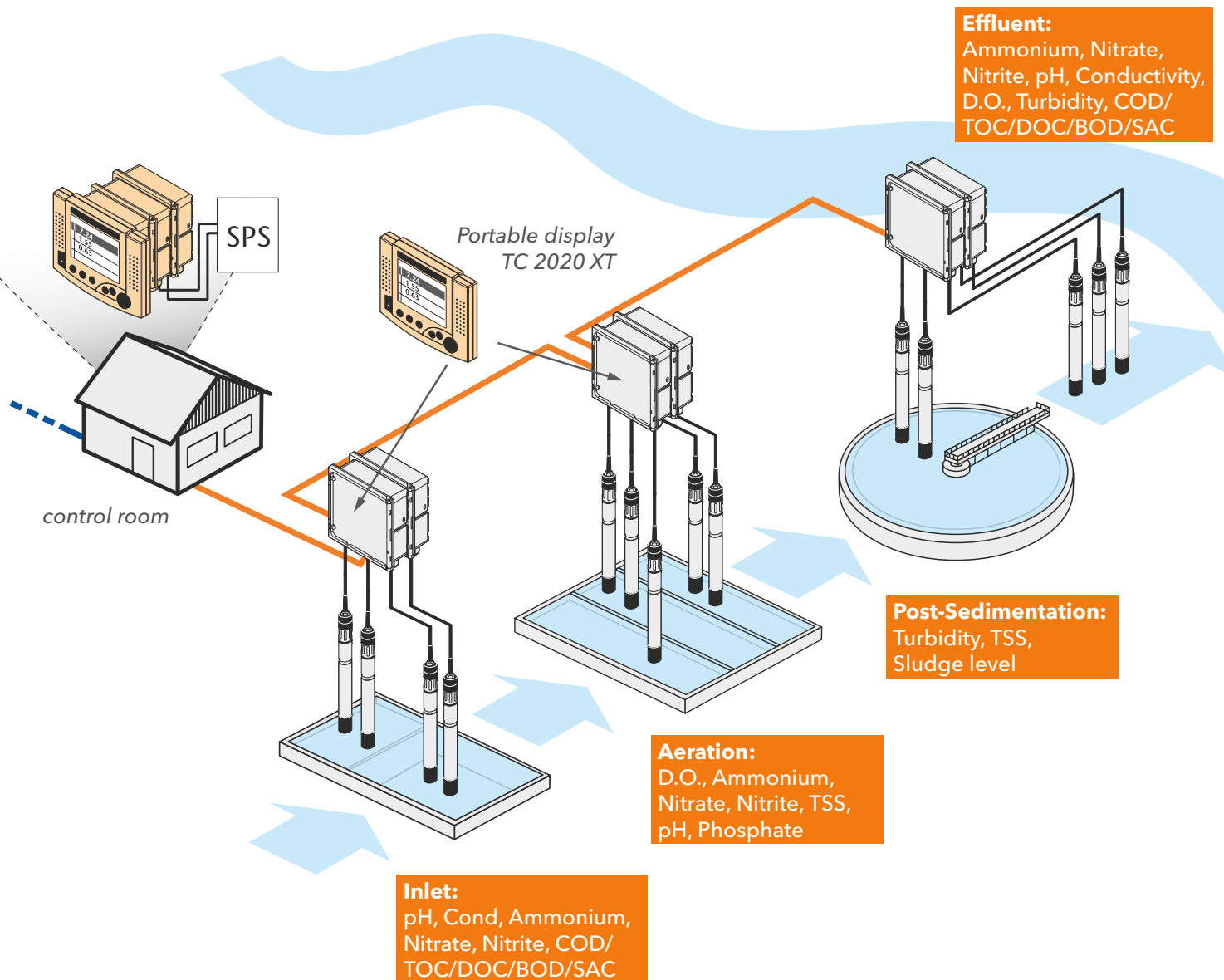

General Description of Meters

IQ SENSOR NET

Monitors

Analyzer

Sample Preparation

Samplers

Accessories

System 2020 XT (USB)

- USB interface
- Electronic-Key function
- IQ-LabLink function

System 2020 XT (Connect)

- LAN & USB interface
- Integrated Web server
- Various TCP/IP Communication protocols
- Profibus and Modbus versions



starting on page 85



Page 88/89

Terminal / Controller MIQ/TC 2020 XT



The terminal/controller MIQ/TC 2020 XT presents the core of each IQ SENSOR NET System 2020. Its high-performance processor coordinates all tasks within the network. Via the USB interface an extremely fast data exchange via USB memory stick to any external system directly is possible. The system-status LED gives reliable and fast information regarding function and status of system.



When integrating two MIQ/TC 2020 XT in the system, the dual-processor function increases the system stability and therefore also availability of the entire system.

Can be operated as terminal and controller all-purpose solution (constantly installed) or as mobile terminal solution.

- Multi-functional USB interface
- Increased system stability through dual-processor function

Network integration

- Remote communication
- Remote maintenance

Status LED display

Each MIQ/TC 2020 XT terminal/controller shows a LED for diagnostic purposes on the front. This LED shows normal and malfunctions of the system at a glance.

Multi-functional USB interface

- IQ-LabLink function
- Electronic-Key function
- Storage of configuration
- Storage of calibration
- Logbook recording
- Storage of recorded data (data logging function)
- Software upload

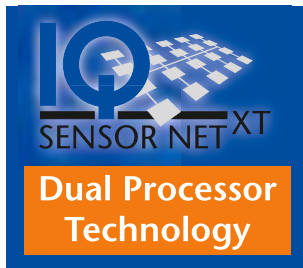

- In case of any failure regarding the central unit (terminal/controller function) the second unit fully automatically takes over both functions (goes fully automatically from the plain terminal operation to the terminal/controller operation).
- Status LED indicates any failures



IQ-LabLink – the link to the world of laboratory

IQ-LabLink enables a safe data exchange between the IQ SENSOR NET and the laboratory instrument. The exchange is processed via a common USB memory stick, serving as data medium between the online system and the laboratory instrument. The condition is that both instruments feature this function and are equipped with a USB interface. The first WTW instruments to include this function are the two new spectrophotometers **photoLab® 6100 VIS** and **photoLab® 6600 UV-VIS** (laboratory instruments) and the **terminal/controller MIQ/TC 2020 XT** with access to the IQ SENSOR NET.

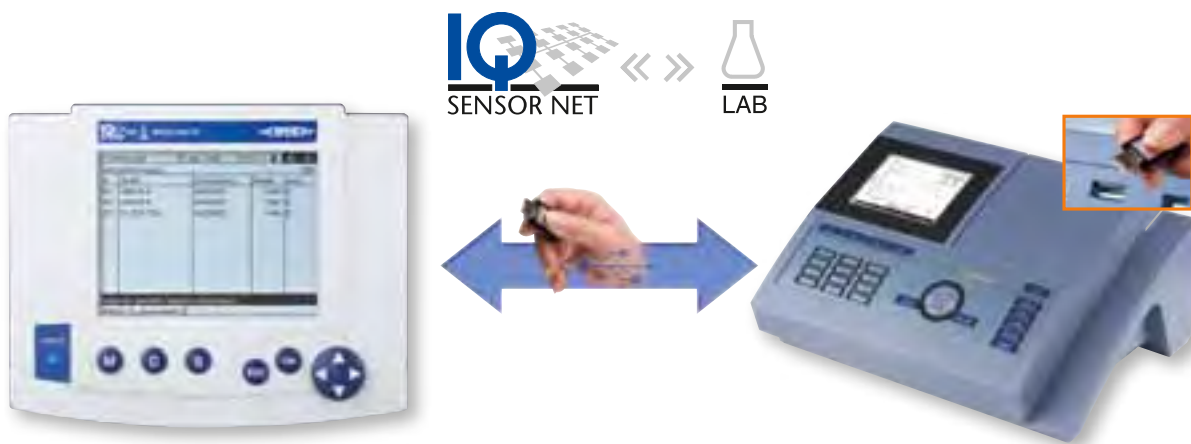

Application example: Matrix adaption with VARION®Plus

The multi-parameter sensor measures ammonium and nitrate at the same time. The ammonium measurement is dynamically compensated by the separate measurement of potassium. As every wastewater has its individual matrix, a precision-adaption is processed occasionally. The values for the matrix adaption are determined using a photometer and provided to the sensor. The value entry was processed manually up to now.

Matrix adaption via IQ-LabLink

Step 1, IQ terminal:

Automatic generation of job files on a USB memory stick with actual sensor values, parameters, description of measuring site and the automatic allocation of job reference number for a unique identification.

Step 2, photometer:

After inserting the USB memory stick, the instrument identifies the job file, asks for the measurement with the according parameters, gives advice for supporting the correct operation, stores all determined data back on the job file and verifies the completeness.

Step 3, IQ terminal:

Complete reading of data related to the matrix adaption by pressing one button, without any interruption of the online measurement.

IQ-LabLink

Advantages at a glance:

- Software supported routines for the safe data transfer from laboratory to online systems.
- Safe and easy allocation of online and laboratory measurement via job files and functions.
- Integrated help functions for correct processing.
- Check for completeness and verification.
- Complete reading of all data using one button without any interruption of the online measurement.

Electronic-Key function with programmable access permission



Electronic-Key function

- Protection against non-authorized access
- Individual access permission

Function:

When the Electronic-Key function in the IQ SENSOR NET system is activated, the USB memory stick works like an electronic key giving access to the system.

A coded file is therefore stored on the USB memory stick. After reading the file access is activated to the system.

It is also possible, to release only certain functions in order to personalize access.



General Description of Meters

IQ SENSOR NET

Monitors

Analyzer

Sample Preparation

Samplers

Accessories

NEW

System 2020 XT (Connect)

The new controller family MIQ/
MC2 by WTW

*Ethernet connection - web server and much more
Easiest network connections - local and via internet*



Measured values are available worldwide at any time

The availability and retrieval of online measurement values - at any time and from anywhere in the world - with the assistance of network connected computers and smart phones, becomes increasingly more important for users in industry and wastewater treatment plants. Modern online measurement technology must therefore provide a simple and cost-effective integration into local networks, and also into the Internet.

ID	Status	Sensor model	Sensor name	Value 1	Value 2
S01	Measuring	SoldeVis701 IQ	12180617	217 mg/l TS	217 #
S02	Measuring	SC PDO 700	07040953	7.48 mg/l O2	22.8 °C
S03	Measuring	CarboVis701 IQ	12180617	347 mg/l CSBps	347 #
S04	Measuring	TetraCon7000Q	01388615	8.1	5Ac 23.6 °C

IQ SENSOR NET measured values displayed via web browser/internet



Housings of the new MIQ/MC2 family with integrated Ethernet/LAN and USB interface.

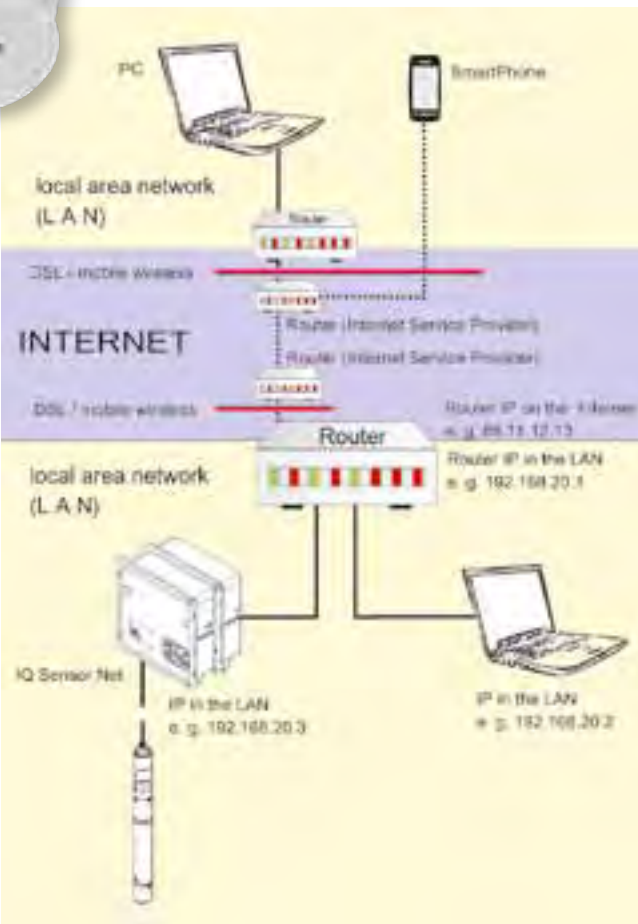

Integration of the IQ SENSOR NET system via Ethernet/LAN and routers into a local network or via the Internet into a second local network.

Ethernet/LAN interface and Web server included – ready to use

WTW continued to raise the bar with the new controller family MIQ/MC2 that has integrated an Ethernet / LAN interface as standard. The integration through existing routers in system networks and the Internet must be implemented easily and inexpensively without additional accessories. Thanks to the integrated Web server, data can be viewed at anytime with Internet-enabled devices such as PCs, tablet PCs or smartphones via web browsers.

General Description of Meters

IQ SENSOR NET

Monitors

Analyzer

Sample Preparation

Samplers

Accessories

General Technical Data System 2020 XT

System

Certifications	ETL, cETL (conforms with relevant UL and Canadian standards), CE	
Electromagnetic Compatibility	EN 61326, Class B; FCC Class A, EMC for indispensable operation	
Integrated Lightning Protection	According to EN 61326 enhanced overvoltage protection for the entire system, implemented in each component	
Connection Medium Cable	IQ SENSOR NET cable SNCIQ or SNCIQ/UG (underground cable with additional PVC coating): 2-wire with shield; 2 x 0.75 mm ² ; Filler cord for easy connection of shield: 0.75 mm ² ; pressure resistant to 10 bar	
Connection Characteristics	Power supply and data transmission on these wires; resistant to polarity reversal with respect to switched shield and inner conductor (no damage); comprehensive EMC shield control; cable topology within IQ Sensor Net system as required, e.g. in the form of a line, tree, star, multiple star Total cable length: max. 1.000 m/1094 yds (without signal amplifying), with signal amplifying module MIQ/JBR additional 1.000 m/1094 yds	
Connection Medium Radio	Radio transmission Class 1 with a range of 100 m/109 yds (max. 300 m/328 yds)	
Connection Characteristics	Data transmission, separate power supply necessary for each island	
Controller	Terminal-/Controller MIQ/TC 2020 XT	Controller MIQ/MC2
MIQ Module Coupling at Rear	Combined mechanical and electrical connection, for rapid coupling to MIQ modules	
USB interface	USB-A (host)	USB-A
Ethernet port	–	RJ45 socket or LSA terminal strip can be used
Display	Graphic display; resolution: 320 x 240 pixel; visible area: 4.49 x 3.39 in. (114 x 86 mm), black/white, backlit	
Control Functions/Function Keys	5 operating keys: 3 master keys for functions: Measurement (M), calibration (C), set/system settings (S), 2 keys for: confirmation/switching menu O.K. (OK), Escape (ESC) 4-directional button for rapid selection of software functions and input of alphanumeric values	
Datalogger	Data memory for up to 525,600 data sets	
Electric Supply	Directly via the IQ SENSOR NET when coupled to MIQ module	
Ambient Conditions	Operating temperature: –4 °F ... 131 °F (–20 °C ... +55 °C) Storage temperature: –13 °F ... 149 °F (–25 °C ... +65 °C)	
Housing Material	ASA (Acrylonitrile-Styrene-Acryloesterpolymer)	
Protection Rating	IP 66 / equivalent to NEMA 4X (not suitable for conduit connection)	
Dimensions (W x H x D)	8.27 x 6.69 x 1.57 in. (210 x 170 x 40 mm)	5.67 x 6.81 x 2.05 in. (144 x 173 x 52 mm)
Weight	Approx. 1.54 pounds (0.7 kg)	
Guaranty	3 years for defects of quality	
Modules		
MIQ Module Coupling at Front	Combined mechanical and electrical connection for rapid docking and removal of the MIQ/T2020 (PLUS) terminal and the MIQ/TC 2020 XT controller, and for docking additional modules	
MIQ Module Coupling at Rear	Combined mechanical and electrical connection for docking additional modules, a total of 3 modules as a stack mounted unit	
Cable Feeds	4 screw cable glands M 16 x 1.5	
Terminal Connections	Screw terminal strips Terminal area for solid conductors: 0.2 ... 4.0 mm ² Terminal area for flexible conductors: 0.2 ... 2.5 mm ² accessible by opening cover	
IQ SENSOR NET Terminal Connections	Terminal connections for the IQ SENSOR NET are available on each module and can be used as required: - for connecting sensors - as an input/output or for looping through/branching of the IQ SENSOR NET cable	
Other Functions	Two LEDs, yellow and red, for monitoring the operating voltage of the IQ SENSOR NET; IQ SENSOR NET connection, resistant to reversed polarity; Integrated local identity function; Integrated switchable terminal resistor (SN terminator)	
Electric Supply	Directly via the IQ SENSOR NET	
Ambient Conditions	Operating temperature: –4 ... 131 °F (–20 ... +55 °C); Storage temperature: –13 ... 149 °F (–25 ... +65 °C)	
Housing Material	PC – 20% GF (polycarbonate with 20% fiberglass)	
Protection Rating	IP 66 / equivalent to NEMA 4X (not suitable for conduit connection)	
Dimensions (W x H x D)	5.67 x 5.67 x 2.05 in. (144 x 144 x 52 mm)	
Weight	Approx. 1.1 pounds (0.5 kg)	
Guaranty	3 years for defects of quality	
Sensors		
Mechanical Connections for Accessories	Connection slot; Connection screw thread G 1"	
IQ Sensor Connection Cable	Combined mechanical and electrical connection for rapid attachment and exchange of sensors. Consists of jack plug and pressure-resistant screw connection. Cable lengths: 1.64 – 7.66 – 16.40 yds (1.5 – 7.0 – 15.0 m)/ 21.87 – 54.68 – 109.36 yds (20 – 50 – 100 m) in sea water design available. Storage temperature: –13 °F ... 149 °F (–25 °C ... +65 °C) Operating temperature: –4 °F ... +131 °F (–20 °C ... +55 °C)	

System components and functions

Terminal/Controller			
	Model	Function	Order No.
Central Control Unit	TC 2020 XT (Operation in MODBUS: terminal/controller)*	Central terminal/controller unit: is required to be installed once at any point, remains in the system, cannot be removed. Operation mode is shown through LED.	470 000
	MIQ/TC 2020 XT-H3	Multi-parameter measuring converter, consisting of the components MIQ/TC 2020 XT + MIQ/CR3 + MIQ/PS, 100 – 240 VAC main voltage, 3 analog outputs (0/4-20 mA) and 3 relay outputs, up to 20 free selectable IQ sensors can be connected	470 016
	MIQ/TC 2020 XT-H3 C6	Multi-parameter measuring converter, consisting of the components MIQ/TC 2020 XT + MIQ/C6 + MIQ/PS, 100 – 240 VAC main voltage, 6 analog outputs (0/4-20 mA) up to 20 free selectable IQ sensors can be connected	470 017
Controller			
	MIQ/MC2	Module IQ/Micro Controller; is required to be installed once at any point; with fully automatic air-pressure compensation and USB + LAN interface	471 015
	MIQ/MC2-MOD	Module IQ/Micro Controller with fully automatic air-pressure compensation and MODBUS RTU / RS 485 connection and USB + LAN interface	471 016
	MIQ/MC2-PR	Module IQ/Micro Controller with fully automatic air-pressure compensation and PROFIBUS-DP connection and USB + LAN interface	471 017
MIQ Modules			
	Model	Function	Order No.
Power Supply	MIQ/PS for 100 – 240 VAC	Depending on the power consumption up to 6 modules can be installed in the system.	480 004
	MIQ/24V for 24 VAC/24 VDC		480 006
Output Modules (analog)	MIQ/CR3 with 3 analog (0/4-20 mA) and 3 relay outputs	With any combination	480 014
	MIQ/C6 with 6 analog outputs (0/4-20 mA)		480 015
	MIQ/R6 with 6 relay outputs		480 013
Output Modules (Digital)	MIQ/2-MOD	Module IQ with fully automatic air-pressure compensation and MODBUS RTU / RS 485 connection	471 018
	MIQ/2-PR	Module IQ with fully automatic air-pressure compensation and PROFIBUS-DP connection	471 019
Magnetic valve module	MIQ/CHV PLUS	Magnetic valve module for automatic controlled cleaning via compressed air	480 018
Linking modules	MIQ/JB	MIQ/JB with 4 connections (for IQ Net or IQ sensors)	480 008
	MIQ/JBR	MIQ/JBR, same as MIQ/JB additionally with amplifier signal for long cable distances (>1 km total length)	480 010
Connecting module Power input	MIQ/IC2	MIQ/IC2 with 2 inputs for 0/4-20 mA signals Enables the connection of separate measuring transmitters and analyzers to the IQ Net	480 016
Radio communication module	MIQ/Blue PS	For wireless connection and linking within the IQ SENSOR NET system	480 021

All IQ sensors are connectable; for ordering information see each parameter chapter. An overview of all connectable sensors can be found in our brochure "Product Details".

**Via the software adjustable by user.*



IQ SENSOR NET performance data

All components within the system require a specific electric power supply. Due to the enormous flexibility of the system, an infinite number of variations are possible. Therefore, a balance sheet must be drawn up after selecting the components. This is easily done by totaling the power consumption of the individual components and checking whether the sum exceeds the power provided by a particular power supply unit. If so, the available power can be increased by installing additional or more powerful power supply units.

Power consumption in Watts	Number of power supply units
MIQ/PS	
≤18 Watts	1 power supply unit
18 - 36 Watts	2 power supply units
36 - 54 Watts	3 power supply units
55 - 72 Watts	4 power supply units
73 - 90 Watts	5 power supply units
91 - 108 Watts	6 power supply units

Additional cable losses generally do not need to be taken into account for installations where the main consumers are near (<164 yds/150 m) the next power supply and the overall cable length does not exceed 437 yds (400 m). In systems with greater cable lengths, approx. 1 watt of power loss per additional 109 yds (100 m) of cable have to be considered. These standard values apply when using specified IQ SENSOR NET cable SNCIQ.

Example

Outlet measurement with the following parameters: turbidity, pH, dissolved oxygen, conductivity and temperature	Components:	Power consumption or power supply	One power supply unit MIQ/PS is sufficient for the complete system consisting of four connected sensors.
	MIQ/PS	+ 18.0 Watts	The system comprises a buffer/reserve of approx. 9 watts. The system can be accordingly extended sensors and components.
	MIQ/TC 2020 XT	- 3.0 Watts	
	MIQ/C6	- 3.0 Watts	
	VisoTurb® 700 IQ	- 1.5 Watts	
	SensoLyt® 700 IQ	- 0.2 Watts	
	TriOxmatic® 700 IQ	- 0.2 Watts	
	TetraCon® 700 IQ	- 0.2 Watts	
	Total	Σ: +9.4 Watts	

MIQ/TC2020 XT
+ MIQ/PS
+ MIQ/C6 (6 x mA)
+ 4 IQ sensors

Multi-parameter monitor for any 4 parameters, with 6 analog outputs

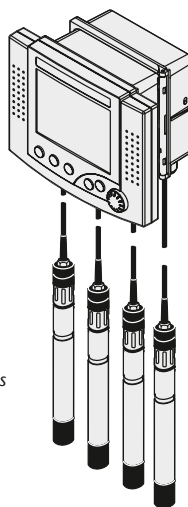

Configuration and Performance Data

IQ Sensors			
Type	Description		Power Consumption/ W
SensoLyt® 700 IQ (SW)	pH/ORP assembly		⇒ 0.2
TriOxmatic® 700 IQ (SW)	D.O. sensor		⇒ 0.2
TriOxmatic® 701 IQ	D.O. sensor		⇒ 0.2
TriOxmatic® 702 IQ	D.O. sensor		⇒ 0.2
FDO® 700 IQ (SW)	Optical D.O. sensor		⇒ 0.7
TetraCon® 700 IQ (SW)	Conductivity sensor		⇒ 0.2
VisoTurb® 700 IQ (SW)	Turbidity sensor		⇒ 1.5
ViSolid® 700 IQ (SW)	Suspended solids sensor		⇒ 1.5
VARION®Plus 700 IQ	Double sensor ammonium and nitrate (ISE)		⇒ 0.2
AmmoLyt®Plus 700 IQ	Ammonium assembly (ISE)		⇒ 0.2
NitraLyt®Plus 700 IQ	Nitrate assembly (ISE)		⇒ 0.2
NitraVis® 70X IQ (TS)	Optical nitrate sensor		⇒ 8.0
CarboVis® 70X IQ (TS)	Optical sensor for the measurement of COD/TOC/DOC/BOD/SAC		⇒ 8.0
NiCaVis® 705 IQ	Optical sensor for the measurement of nitrate and COD/TOC/DOC/BOD/SAC		⇒ 8.0
NiCaVis® 70X IQ NI	Optical sensor for the measurement of nitrate, nitrite and COD/TOC/DOC/BOD/SAC/TUV ₂₅₄		⇒ 8.0
P 700 IQ	Orthophosphate analyzer		⇒ 0.5
IFL 700 IQ	Sludge level sensor with integrated scraper		⇒ 5.5**
IFL 701 IQ	Sludge level sensor without scraper		⇒ 3.0
Output modules analog			
Type	Description	In total there are 48 output channels/ system available	Power Consumption/ W
	Each mA-output, each relays with one module is considered as 1 channel.	Number of occupied output channels	
MIQ/CR3	IQ / current relay 3 module. with 3 analog outputs and 3 relay outputs each	6	⇒ 3.0
MIQ/C6	IQ / current 6 module with 6 analog outputs	6	⇒ 3.0
MIQ/R6	Module IQ/ Relays 6 with 6 analog outputs	6	⇒ 1.5
MIQ/CHV PLUS	Module IQ/ Cleaning Head Valve for automatically controlled cleaning	1	⇒ 1.0
Output modules digital			
Type	Description		Power Consumption/ W
MIQ/2 PR	Module IQ with PROFIBUS-DP connection		⇒ 2.0
MIQ/2 MOD	Module IQ with MODBUS RTU / RS 485 connection		⇒ 1.6
MIQ/Blue PS	Module IQ for wireless connection within the IQ SENSOR NET system		⇒ 0.6
MIQ/IF232	IQ / software terminal module		⇒ 0.2
Power input connection module mA			
Type	Description		Power Consumption/ W
MIQ/IC2**	IQ / input current 2, module with 2 inputs for 0 / 4 - 20 mA signals **each occupied current input is counted as IQ sensor		⇒ 0.2*
MIQ/JB	IQ / junction box module		⇒ 0.0 (non-active module)
MIQ/JBR	IQ / junction box repeater module		⇒ 0.2
Terminal-Controller			
Type	Description		Power Consumption/ W
MIQ/TC 2020 XT	Terminal / controller for system 2020 XT	In total 3 units per system possible, whereby 1 is installed constantly to the station (terminal / controller function) and 2 are removable or replaceable (terminal function)	⇒ 3.0
Controller			
Type	Description		Power Consumption/ W
MIQ/MC2	Module IQ/Micro Controller		⇒ 1.6
MIQ/MC2-PR	Module IQ/Micro Controller with PROFIBUS-DP connection		⇒ 2.0
MIQ/MC2-MOD	Module IQ/Micro Controller with MODBUS RTU / RS-485 connection		⇒ 1.6
Power supply modules			
Type	Description		Power Output/ W
MIQ/PS	IQ / power supply module for input power with wide range power supply unit for 100 - 240 VAC input voltage		18 ⇒
MIQ/24V	IQ / 24 V module for input power with 24 VAC or 24 VDC input voltage		18 ⇒

Attention: Please consider power consumption of SNCIQ cable: 1 W per 100 m/109 yds (for cable lengths above 400 m/437 yds)

*(+2.2 W per connected power supply/isolator)

** operating with MIQ/Blue PS: 3,0 W



System 182

Up to 4 digital sensors can be connected to this system – insofar the system 182 is perfectly designed for the operation or completion of single measuring points at wastewater plants:

System 182

- 1 to 4 sensors
- Digital outputs
- All IQ sensors can be connected

- Up to 4 sensors can be connected out of a variety of 19 available digital sensors
- pH, ORP, D.O., conductivity, temperature and turbidity/ suspended solids, nutrient parameters ammonium, nitrate and COD can therefore be measured directly, in-situ
- Power supply through wide range mains converter (100-240 VAC) or 24 V alternative.
- Digital outputs PROFIBUS DP or MODBUS RTU
- Analog model with up to 5 analog outputs and 6 relays

Module	DIQ/S 182	DIQ/S 182 XT	DIQ/S 182 XT-4
			
Max. number of sensors	2	2	4
Plug connection for Bus	Plug connection for Bus 2 x mA (0) 4 - 20 mA 3 x relay	DIQ/S 182 XT 4 x mA (0) 4 - 20 mA 5 x relay	DIQ/S 182 XT-4 5 x mA (0) 4 - 20 mA 6 x relay
Models with digital output PROFIBUS	DIQ/S 182 PR Plug connection for Bus 3 x relay	—	DIQ/S 182 XT-4/ PR Plug connection for Bus 3 x relay
Models with digital output MODBUS	DIQ/S 182 PR Plug connection for Bus 3 x relay	—	DIQ/S 182 XT-4/ PR Plug connection for Bus 3 x relay

Linking module for sensors and magnetic valve modules for compressed-air cleaning



- (DIQ/JB): Connection of a second or further distant IQ sensor
- (DIQ/CHV): Integrated magnetic valve is directly controlled by a relay of the transmitter

Configuration Options for System 182

Example 1

Configuration Example	Order No.
DIQ/S 182	472 000
SACIQ-7,0	480 042
IQ Sensor	user selected



Transmitter with 1 direct connected IQ sensor

Example 2

Configuration Example	Order No.
DIQ/S 182 XT	472 001
2 x SACIQ-7,0	480 042
2 IQ Sensors	user selected

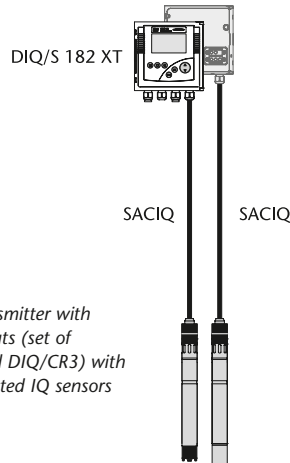

2 channel transmitter with 4 analog outputs (set of DIQ/S 182 and DIQ/CR3) with 2 direct connected IQ sensors

Example 3

Configuration Example	Order No.
DIQ/S 182 XT-4	472 015
4 x SACIQ-7,0	480 042
DIQ/JB	472 005
4 IQ Sensors	user selected

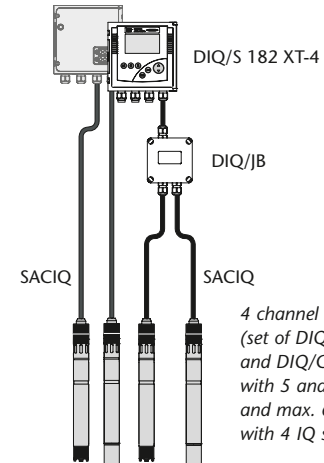

4 channel transmitter (set of DIQ/S 182 and DIQ/CR3) with 5 analog outputs and max. 6 relays with 4 IQ sensors

Single measuring point with analog outputs

Configuration Example	Order No.
DIQ/S 182 XT-4	472 015
3 x SACIQ-7,0	480 042
VARiON [®] Plus 700 IQ	107 066
2 IQ Sensors	user selected

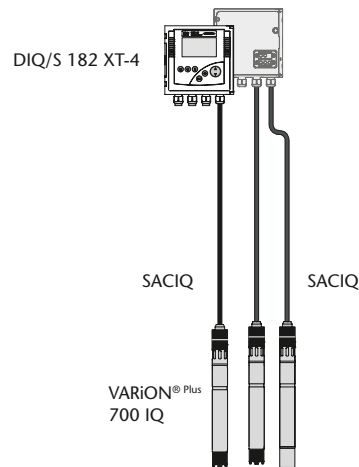

4 channel transmitter (set of DIQ/S 182 and DIQ/CR3) with 5 analog outputs and max. 6 relays with 3 IQ sensors

Single measuring point PROFIBUS / MODBUS

Configuration Example	Order No.
DIQ/S 182 XT-4-PR	472 017
4 x SACIQ-7,0	480 042
4 IQ Sensors	user selected

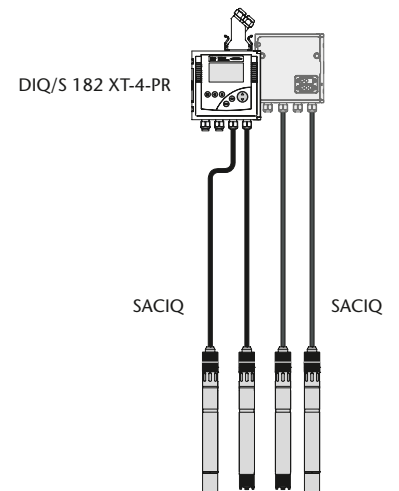

4 channel transmitter (set of DIQ/S 182 and MIQ/JB) with 3 relays and PROFIBUS-DPA connection with 4 IQ Sensors

General Description of Meters

IQ SENSOR NET

Monitors

Analyzer

Sample Preparation

Samplers

Accessories

Ordering Information System 182

		Order No.
Monitors		
DIQ/S 182	Dual IQ/system 182, Universal Transmitter for connection of 2 digital IQ sensors with 2 analog outputs (0/4-20 mA) and 3 relays	472 000
DIQ/S 182 XT	Dual IQ/ system 182, Universal Transmitter for connection of 2 digital IQ sensors, with 4 analog outputs (0/4-20 mA) and 5 relays	472 001
DIQ/S 182-PR	Dual IQ/system 182, Universal Transmitter for connection of 2 digital IQ sensors, with 3 relays and PROFIBUS-DP connection	472 002
DIQ/S 182-MOD	Dual IQ/system 182, Universal Transmitter for connection of 2 digital IQ sensors, with 3 relays and MODBUS RTU/RS 485 connection	472 003
DIQ/S 182/24V	Dual IQ/system 182, Universal Transmitter for connection of 2 digital IQ sensors, with 2 analog outputs (0/4-20 mA) and 3 relays, for 24 V AC/DC power supply	472 010
DIQ/S 182 XT/24V	Dual IQ/ system 182, Universal Transmitter for connection of 2 digital IQ sensors, with 4 analog outputs (0/4-20 mA) and 5 relays, for 24 V AC/DC power supply	472 011
DIQ/S 182-PR/24V	Dual IQ/system 182, Universal Transmitter for connection of 2 digital IQ sensors, with 3 relays and PROFIBUS-DP connection, for 24 V AC/DC power supply	472 012
DIQ/S 182-MOD/24V	Dual IQ/system 182, Universal Transmitter for connection of 2 digital IQ sensors, with 3 relays and MODBUS RTU/RS 485 connection, for 24 V AC/DC power supply	472 013
DIQ/S 182 XT-4	Dual 182 XT-4 system for connecting 4 digital sensors with 5 analog outputs (0/4 - 20 mA) and max 6 relays. Delivery scope DIQ/S with DIQ/CR3	472 015
DIQ/S 182 XT-4-PR	Dual 182 XT-4 system for the connection of 4 digital sensors with 3 relays and PROFIBUS-DP connection, delivery scope DIQ/S 182 with MIQ/JB	472 017
DIQ/S 182 XT-4-MOD	Dual 182 XT-4 system for the connection of 4 digital sensors with 3 relays and MODBUS RTU / RS-485 connection, delivery scope DIQ/S 182 with MIQ/JB	472 019
DIQ/S 182 XT-4/24V	Dual 182 XT-4 system for the connection of 4 digital sensors with 5 analog outputs (0/4 - 20 mA) and max 6 relays for the 24 V AC/DC power supply, delivery scope DIQ/S 182/24V with DIQ/CR3	472 021
DIQ/S 182 XT-4-PR/24V	Dual 182 XT-4 system for the connection of 4 digital sensors with 3 relays and PROFIBUS-DP connection for 24V AC/DC power supply, delivery scope DIQ/S 182 24V with MIQ/JB	472 023
DIQ/S 182 XT-4-MOD/24V	Dual 182 XT-4 system for the connection of 4 digital sensors with 3 relay outputs and MODBUS RTU / RS 485 connection for 24 V AC/DC power supply, delivery scope DIQ/S 182/24V with MIQ/JB	472 024
DIQ Modules		Order No.
DIQ/JB	Dual IQ/Junction box for connection of a second or a further IQ sensor to the Universal Transmitter DIQ/S 182 (system 182)	472 005
DIQ/CHV	Dual IQ/Cleaning Head Valve for automatic air cleaning controlled by a relay for system 182 (relay and compressed air supply external)	472 007
MS/DIQ	Mounting plate for up to 2 DIQ modules (DIQ/CHV and DIQ/JB)	472 009
MIQ Module and Cables for System Supplement		Order No.
MIQ/Blue PS SET	Module IQ/Radio transmission, for wireless connection within the IQ SENSOR NET system, for system 182, 184 XT and 2020 XT. SET with two pairwise preconfigured modules	480 021
MIQ/CR3	Output Module (analog) with 3 analog and 3 relay outputs, with any combination	480 014
MIQ/C6	Output Module (analog) with 6 analog outputs, with any combination	480 015
MIQ/R6	Output Module (analog) with 6 relay outputs, with any combination	480 013
MIQ/IC2	MIQ/IC2 with 2 inputs for 0/4-20 mA signals Enables the connection of separate measuring transmitters and analyzers to the IQ Net	480 016
MIQ/JB	Linking with 4 connections (for IQ Net or IQ sensors)	480 008
MIQ/CHV PLUS	Magnetic valve module for automatic controlled cleaning via compressed air	480 018
MIQ/PS	Module IQ/Power Supply, wide-range power supply for system 182, 2020 XT and 184 XT, power output max. 18 W	480 004
MIQ/24V	Module IQ/24V, power supply for 24 VAC / 24 VDC input voltage, for system 182, 2020 XT and 184 XT, power output max. 18 W	480 006
SNCIQ	Specific two-wire IQ SENSOR NET cable with shield for safe power/information transfer within the IQ SENSOR NET system. Please indicate cable length in m when ordering (unit: m)	480 046
SNCIQ/UG	Specific two-wire IQ SENSOR NET cable with shield for safe power/information transfer within the IQ SENSOR NET system, esp. for use in underground. Please indicate cable length in m when ordering (unit: m)	480 047



Mounting Material for Monitors on request / see brochure "Product Details"



Monitors

EcoLine / QuadroLine® – Analog monitors for D.O., pH and Conductivity

Easy of use and maximum operating safety at an attractive price were the basic design criteria for the development of the EcoLine monitors. As a result of the logical further development of the successful EMC concept, WTW has also been able to make these advantages available to customers at an attractive price.

Analog monitors

- Outstanding price/performance ratio
- Built-in lightning protection
- Galvanically isolated inputs and outputs

Oxi 170, pH 170, LF 170

With the EcoLine series WTW offers an economical and technically flexible and reliable system solution which is suitable for a wide range of applications water and wastewater applications.

Oxi 296, pH 296, LF 296

The QuadroLine® series is an extremely powerful monitor in a compact form and at an attractive price-performance ratio. These monitors are intended to be built into control panels and fulfill all the requirements which industrial practice demands from such systems today. Based on the proven technology of the WTW monitors of the EcoLine family, the QuadroLine® instruments have the same impressive performance features. EcoLine and QuadroLine® monitors are the right choice when single point measurements require a dedicated monitor.



EcoLine 170



QuadroLine® 296

Configuration Guide

		EcoLine Oxi 170	QuadroLine® Oxi 296
1. Measuring range 2. Response time t_{90} 3. SensCheck Function		Field monitor	Panel mount
TriOxmatic® 690 D.O. sensor for water / wastewater	1.: 0.0 ... 60,0 mg/l 0 ... 600% 2.: <180 s 3.: –	<ul style="list-style-type: none"> • Low-cost system without sensor diagnostic • Water / wastewater • Oxygenation 	
TriOxmatic® 700 D.O. sensor for water / wastewater	1.: 0.0 ... 60.0 mg/l 0 ... 600% 2.: <180 s 3.: SensLeck SensReg	<ul style="list-style-type: none"> • Water / wastewater • Oxygenation 	
TriOxmatic® 700 IN D.O. sensor for water / wastewater with permanent polarization	1.: 0.0 ... 60.0 mg/l 0 ... 600% 2.: <180 s 3.: SensLeck	<ul style="list-style-type: none"> • Industrial wastewater • Oxygenation 	
TriOxmatic® 701 D.O. sensor for water / wastewater	1.: 0.00 ... 20.00 mg/l 0.0 ... 60.0 mg/l 0.0 ... 200.0% 0 ... 600% 2.: <30 s 3.: SensLeck SensReg	<ul style="list-style-type: none"> • Water / wastewater • Oxygenation • Residual D.O. 	
		EcoLine pH 170	QuadroLine® pH 296
		Field Monitor	Panel Mount
SensoLyt® 650 Sensor Assembly w/o preamplifier, high-impedance output, integrated temp. measurement, 32 ... 122 °F (0 ... 50 °C)	Compatible electrodes: SEA: 2 ... 12 pH SEA-HP: 4 ... 12 pH DWA: 0 ... 14 pH ECA: 2 ... 12 pH PtA: ±1000 mV 32 ... 140 °F (0 ... 60 °C)	<ul style="list-style-type: none"> • Low-cost configuration • High impedance signal transmission • pH measurement in highly polluted wastewater (municipal/industrial) Type SEA • pH measurement in normally polluted wastewater (municipal/industrial) Type ECA • pH measurement in drinking water (DWA) • ORP measurement in highly polluted wastewater (municipal/industrial) Type PtA • Inline installation (SEA or SEA-HP) 	
SensoLyt® 650 Sensor Assembly w/integrated preamplifier, low-impedance output, integrated temp., measurement 32 ... 122 °F (0 ... 50 °C)	Compatible electrodes: SEA: 2 ... 12 pH SEA-HP: 4 ... 12 pH DWA: 0 ... 14 pH ECA: 2 ... 12 pH PtA: ±1000 mV 32 ... 140 °F (0 ... 60 °C)	<ul style="list-style-type: none"> • Low-cost configuration • Low impedance signal transmission • pH measurement in highly polluted wastewater (municipal/industrial) Type SEA • pH measurement in normally polluted wastewater (municipal/industrial) Type ECA • pH measurement in drinking water (DWA) • ORP measurement in highly polluted wastewater (municipal/industrial) Type PtA • Inline installation (SEA or SEA-HP) 	
SensoLyt® 700 Sensor Assembly w/integrated pre-amplifier, low-impedance output, integrated temp. measurement 32 ... 122 °F (0 ... 50 °C) and SensorCheck	Compatible electrodes: SEA: 2 ... 12 pH SEA-HP: 4 ... 12 pH DWA: 0 ... 14 pH ECA: 2 ... 12 pH PtA: ±1000 mV 32 ... 140 °F (0 ... 60 °C)	<ul style="list-style-type: none"> • Low impedance signal transmission • SensCheck • pH measurement in highly polluted wastewater (municipal/industrial) Type SEA • pH measurement in normally polluted wastewater (municipal/industrial) Type ECA • pH measurement in drinking water (DWA) • ORP measurement in highly polluted wastewater (municipal/industrial) Type PtA • Inline installation (SEA or SEA-HP) 	
CHEMtrac 830 M pH/ORP Valve assembly with flushing for cleaning and calibration; Material: 316 L SS 16 bar/284 °F (140 °C)	Compatible electrodes: PL 80-225 pH 0 ... 14 pH, 0 ... 130 °C PL 81-225pHT VP 0 ... 14 pH, 0 ... 130 °C PL 82-225pHT VP 0 ... 14 pH, 0 ... 130 °C PL 89-225pt 0 ... 14 pH, 0 ... 130 °C	<ul style="list-style-type: none"> • High impedance signal transmission • In-line pH measurement in process lines or pressure vessels • Increased pressure/temperature requirements 16 bar/284 °F (140 °C) • Built-in temperature measurement with PL 81-225pHT VP or PL 82-225pHT VP 	

— Not Applicable

Configuration Guide

	1. Measuring range 2. Cell constant 3. Probe type 4. Temperature compensation 5. Temperature range 6. Pressure range 7. Protection rating	EcoLine LF 170 Field Monitor	QuadroLine® LF 296 Pannel Mount Monitor
TetraCon® 700	1.: 10 µS/cm ... 1000 mS/cm 2.: K=0.917 cm ⁻¹ 3.: 4-electrode cell 4.: NTC 5.: 32 ... 122 °F (0 ... 50 °C) 6.: 10 bar 7.: IP 68 (electrode)	Water/Wastewater Usable Measuring Range: 0,0 ... 199,0 µS/cm 0,000 ... 1,999 mS/cm 0,00 ... 19,99 mS/cm 0,0 ... 199,9 mS/cm 32 ... 122 °F (0 ... 50 °C)	
LRD 01	1.: 0,01 ... 200 µS/cm 2.: K=0.1 cm ⁻¹ 3.: 2-electrode cell 4.: NTC 5.: 32 ... 266 °F (0 ... 130 °C) 6.: 14 bar (68 °F/20 °C) 7.: IP 68 (electrode)	Boiler Feed Water/Ion Exchanger; In-Line Measurements/Pipework Mounting 1/2" NPT Thread Usable Measuring Range: 0,00 ... 19,99 µS/cm 0,0 ... 199,9 µS/cm 32 ... 266 °F (0 ... 130 °C); 14 bar (68 °F/20 °C)	
LRD 325	1.: 1 µS/cm ... 2 S/cm 2.: K=0.475 cm ⁻¹ 3.: 4-electrode cell 4.: NTC 5.: 32 ... 212 °F (0 ... 100 °C) 6.: 10 bar 7.: IP 68 (electrode)	Large Usable Measuring Range; In-Line Measurements/Pipework Mounting 1/2" (3/4" Adapter) NPT Thread 0,0 ... 199,0 µS/cm 0 ... 1999 µS/cm 0,00 ... 19,99 mS/cm 0,0 ... 199,9 mS/cm (MR: 0,0 ... 199,9 mS/cm to 110,0 mS/cm at 122 °F/50 °C) 32 ... 212 °F (0 ... 100 °C); 10 bar at 68 °F (20 °C)	
LR 325/01	1.: 0.001 ... 300 µS/cm 2.: K=0.1 cm ⁻¹ 3.: 2-electrode cell 4.: NTC 5.: 32 ... 212 °F (0 ... 100 °C) 6.: 2 bar 7.: IP 68 (electrode)	Boiler Feed Water/Ion Exchanger; Conductivity Cell with Flow-thru Chamber; Usable Measuring Range: 0,00 ... 19,99 µS/cm 0,0 ... 199,9 µS/cm 0,000 ... 0,200 mS/cm 32 ... 122 °F (0 ... 50 °C)	
LR 325/001	1.: 0.0001 ... 30 µS/cm 2.: K=0.01 cm ⁻¹ 3.: 2-electrode cell 4.: NTC 5.: 32 ... 212 °F (0 ... 100 °C) 6.: 2 bar 7.: IP 68 (electrode)	Boiler Feed Water/Ion Exchanger; Conductivity Cell with Flow-thru Chamber, Trace Measurements Usable Measuring Range: 0.000 ... 1.999 µS/cm 0.00 ... 19.99 µS/cm 32 ... 122 °F (0 ... 50 °C)	
TetraCon® 325	1.: 1 µS/cm ... 2 S/cm 2.: K=0.475 cm ⁻¹ 3.: 4-electrode cell 4.: NTC 5.: 32 ... 212 °F (0 ... 100 °C) 6.: 2 bar 7.: IP 68 (electrode)	General Application/Water; Large Measuring Range 0.00 ... 19.99 µS/cm 0.0 ... 199.9 µS/cm 0.000 ... 1.999 mS/cm 0.00 ... 19.99 mS/cm 0.0 ... 199.9 mS/cm (32 ... 77 °F/0 ... 25 °C) 32 ... 122 °F (0 ... 50 °C) (MR: 0.0 ... 199.9 mS/cm up to 110.0 mS/cm at 122 °F/50 °C)	
TetraCon® DU/T	1.: 1 µS/cm ... 2 S/cm 2.: K=0.778 cm ⁻¹ 3.: 4-electrode cell 4.: NTC 5.: 32 ... 140 °F (0 ... 60 °C) 6.: 2 bar 7.: IP 65	Flow-thru cell Usable Measuring Range: 0.00 ... 19.99 µS/cm 0.0 ... 199.9 µS/cm 0.000 ... 1.999 mS/cm 0.00 ... 19.99 mS/cm 0.0 ... 199.9 mS/cm 32 ... 122 °F (0 ... 50 °C)	

— Not Applicable

Technical Data EcoLine Oxi 170 / QuadroLine® Oxi 296

	D.O. Measurement	
Measuring Ranges	0.0 ... 60.0 mg/l or 0 ... 600% saturation, user-selectable, depending on sensor type	
Resolution	0.1 mg/l or 0.01 mg/l; 1% or 0.1% (depending upon the sensor)	
Accuracy	±1% of value, ±1 Digit	
Signal Input	Low-impedance, isolated from output	
Temperature Measurement	NTC resistor (integrated in the sensor), 23 ... 122 °F (–5 °C ... +50 °C); 0.1 K resolution	
Temperature Compensation	Range: 23 ... 212 °F (–5 °C ... +100 °C)	
Atmospheric Pressure Correction	Range: 500 ... 1100 mbar; manual parameter input	
Salinity Correction	2.0 ... 70.0	
Relay Outputs	1 Sensor alarm relay (SensReg/SensLeck function) 2 programmable relays (setpoints, delay, hysteresis), ① + ② Relays are from C rated 5 A at 250 VAC, max. 5 A @ 30 VDC resistive	
Analog Outputs	0/4–20 mA output for D.O. and in versions ① + ② additionally for temperature, max. load 600 Ω; output span and recorder damping adjustable by software	
Digital Interface	RS 485 Interface; bus operation possible with up to 31 units ②	
Ambient Conditions	Operating temperature: –13 °F ... 131 °F (–25 °C ... +55 °C); Storage temperature: –13 °F ... 149 °F (–25 °C ... +65 °C); Clima class 4 (VDI/VDE 3540)	
Electrical Connections	Oxi 170	Sensor input: quick disconnect 7-pole receptacle Outputs, mains supply: via plug-in terminal strips
	Oxi 296	Sensor input, signal inputs and outputs, mains supply: via plug-in terminal strips; accessible from rear
Input Power	115/230 VAC (–15/+10%), 48 ... 62 Hz (18 VA max.), 24 VAC (–15/+10%), 24 VDC (–30/+20%)	
Integrated Lightning Protection	Coarse and fine protection, surpasses EN 61326 requirements	
EMI/RFI Conformance	EN 61326 class B, FCC Class A	
Certifications	CE	
Housing	Oxi 170	Watertight housing (PC/GF20) with threaded receptacle and four cable feed-through connections (PG compression fittings, 10–14 mm dia.); Protection rating IP 66 (exceeds NEMA 4X)
	Oxi 296	Fiberglass-reinforced Noryl housing with membrane keypad (Polyester); Protection rating IP 54 (front panel)
Dimensions	Oxi 170	8.74 x 7.95 x 4.13 in. (222 x 202 x 105 mm, W x H x D)
	Oxi 296	3.78 x 3.78 x 7.32 in. (96 x 96 x 186 mm, W x H x D)
Weight	Oxi 170	Approx. 7.7 lb (3.5 kg)
	Oxi 296	Approx. 2.2 lb (1 kg)
Guaranty	3 years for defects of quality	

Ordering Information

EcoLine Oxi 170		Order No.
Oxi 170, 230 VAC	D.O. field monitor, 230 VAC 50/60 Hz; standard model	281 112
Oxi 170 RT, 230 VAC	Same as standard model, with 2 programmable relays and second analog output for temperature	282 212
Oxi 170 RT RS, 230 VAC	Same as standard model, with 2 programmable relays and second analog output for temperature and RS 485 interface	282 222
QuadroLine® Oxi 296		Order No.
Oxi 296, 230 VAC	D.O. panel mount monitor, 230 VAC 50/60 Hz; standard model	291 112
Oxi 296 RT, 230 VAC	Same as standard model, with 2 programmable relays and second analog output for temperature	292 212
Oxi 296 RT RS, 230 VAC	Same as standard model, with 2 programmable relays and second analog output for temperature and RS 485 interface	292 222

EcoLine Oxi 170:



QuadroLine® Oxi 296:



Other power supplies see brochure "Product Details"

① R-T-version, ② R-T-RS-version

Technical Data EcoLine pH 170 / QuadroLine® pH 296

	pH Measurement	ORP Measurement	Temperature Measurement
Measuring Ranges	0.00 ... 14.00 pH	-1500 mV ... +1500 mV	NTC: 23 °F ... 212 °F (-5 °C ... 100 °C) Pt 100/Pt 1000: -4 °F ... 266 °F (-20 °C ... 130 °C)
Resolution	0.01 pH	1 mV	0,1 K
Accuracy (±1 Digit)	±0.01 pH	±2 mV	NTC: ±0.2 K; Pt 100/Pt 1000: ±0.1 K fine adjustment ±0.5 K
Signal Input	Low-impedance or high impedance	Low-impedance or high impedance	2-conductor (NTC); 3-conductor (Pt 100/Pt 1000)
Temperature Measurement	NTC thermistor, integrated in SensoLyt® sensor assembly; or separate NTC/Pt 100/Pt 1000		
Temperature Compensation	NTC: 23 °F ... 212 °F (-5 °C ... 100 °C); Pt 100/Pt 1000: -4 °F ... 266 °F (-20 °C ... 130 °C)		
Calibration	AutoCal1: automatic calibration with technical buffer solutions AutoCal2: automatic calibration with technical buffer solutions and subsequent analog output of buffer used in calibration ConCal®: manual calibration with any buffer solution		
Calibration Range	Slope range: -62 mV/pH ≤ S ≤ -50 mV/pH Asymmetry potential: -45 mV ≤ U _{asy} ≤ +45 mV		
Display	Dual numeric LCD-readout, 3 1/2 digits for values and display of units; graphic symbols for auxiliary information and operator guidance		
Relay Outputs	Ⓢ Sensor alarm relay (sensor failure); 2 programmable relays (setpoints, delay, hysteresis, control functions) Ⓢ + Ⓢ; Relays are from C rated 5 A at 250 VAC, max. 5 A @ 30 VDC resistive		
Analog Outputs	0/4 - 20 mA output for pH/ORP and in versions Ⓢ + Ⓢ additionally for temperature; max. load 600 Ω; output span and recorder damping adjustable by software		
Digital Interface	RS 485 Interface; bus operation with up to 31 instruments possible Ⓢ		
Ambient Conditions	Operating temperature: -13 °F ... 131 °F (-25 °C ... +55 °C); Storage temperature: -13 °F ... 149 °F (-25 °C ... +65 °C); Clima class 4 (VDI/VDE 3540)		
Electrical Connections	pH 170	Sensor input: quick disconnect 7-pole receptacle Signal inputs and outputs, mains supply: via plug-in terminal strips	
	pH 296	Sensor input, signal inputs and outputs, mains supply: via plug-in terminal strips; accessible from rear	
Input Power	115/230 VAC (-15/+10%), 48-62 Hz (18 VA max.); 24 VAC (-15/+10%), 24 VDC (-30/+20%)		
Integrated Lightning Protection	Coarse and fine protection, surpasses EN 61326 requirements		
EMI/RFI Conformance	EN 61326 class B, FCC Class A		
Certifications	CE		
Housing	pH 170	Watertight housing (PC/GF20) with threaded receptacle and four cable feed-through connections (PG compression fittings, 10 - 14 mm dia.); Protection rating IP 66 (exceeds NEMA 4X)	
	pH 296	Fiberglass-reinforced Noryl housing with membrane keypad (Polyester); Protection rating IP 54 (front panel)	
Dimensions	pH 170	8.74 x 7.95 x 4.13 in. (222 x 202 x 105 mm, WxHxD)	
	pH 296	3.78 x 3.78 x 7.32 in. (96 x 96 x 186 mm, WxHxD)	
Weight	pH 170	Approx. 7.7 lb (3.5 kg)	
	pH 296	Approx. 2.2 lb (1 kg)	
Guaranty	3 years for defects of quality		

Ordering Information

EcoLine pH 170		Order No.
pH 170, 230 VAC	pH/ORP field monitor, 230 VAC 50/60 Hz; standard model	181 112
pH 170 RT, 230 VAC	Same as standard model, with 2 programmable relays and second analog output for temperature	182 212
pH 170 RT RS, 230 VAC	Same as standard model, with 2 programmable relays and second analog output for temperature and RS 485 interface	182 222
QuadroLine® pH 296		Order No.
pH 296, 230 VAC	pH/ORP panel mount monitor, 230 VAC 50/60 Hz; standard model	191 112
pH 296 RT, 230 VAC	Same as standard model, with 2 programmable relays and second analog output for temperature	192 212
pH 296 RT RS, 230 VAC	Same as standard model, with 2 programmable relays and second analog output for temperature and RS 485 interface	192 222

EcoLine pH 170:



QuadroLine® pH 296:



Other power supplies see brochure "Product Details"

Ⓢ R-T-version, Ⓢ R-T-RS-version

Technical Data EcoLine LF 170 / QuadroLine® LF 296

	Conductivity Measurement	
Compatible Sensors	2-electrode or 4-electrode conductivity cells	
Signal Input	Galvanically isolated	
Measuring Ranges (Cell Constants)	0.000 ... 1.999 µS/cm (0.01 cm ⁻¹); 0.00 ... 19.99 µS/cm (0.01 cm ⁻¹ , 0.1 cm ⁻¹); 0.0 ... 199.9 µS/cm (0.1 cm ⁻¹ , 1 cm ⁻¹); 0.000 ... 1.999 mS/cm (0.1 cm ⁻¹ , 1 cm ⁻¹); 0.00 ... 19.99 mS/cm (1 cm ⁻¹); 0.0 ... 199.9 mS/cm (1 cm ⁻¹ , 10 cm ⁻¹); 0 ... 1000 mS/cm (10 cm ⁻¹)	
Resolution	0.001 µS/cm to 1 mS/cm (depending on measuring range)	
Accuracy	±0.5% of value, ±1 digit	
Span of Cell Constants	0.09 cm ⁻¹ ... 1.5 cm ⁻¹ (variable)	
Reference Temperature	68 °F or 77 °F (20 °C or 25 °C), user-selectable	
Measuring Range/ Salinity	0.0 ... 70.0; resolution 0.1 (reference temperature 68 °F/20 °C)	
Temperature Measurement	23 °F ... 266 °F (-5 °C ... +130 °C); depending on temperature sensor	
Temperature Accuracy	±0.2 K, ±1 Digit	
Temperature Compensation	Linear temperature coefficient: 0,5 to 3,0% /K (freely adjustable); non-linear function "nLF": according to DIN EN 27888 for natural waters	
Display	Dual numeric LCD-readout, 3 1/2 digits for values and display of units; graphic symbols for auxiliary information and operator guidance	
Relay Outputs	2 programmable relays (limit values, hysteresis) ① + ②; Relays are from C rated 5 A at 250 VAC, max. 5 A @ 30 VDC resistive	
Analog Outputs	0/4 - 20 mA output for conductivity (σ) and in versions ① + ② additionally for temperature, (600 Ω max. load); output span and recorder damping adjustable via software	
Digital Interface	RS 485 Interface; bus operation with up to 31 instruments possible ②	
Ambient Conditions	Operating temperature: -13 °F ... 131 °F (-25 °C ... +55 °C); Storage temperature: -13 °F ... 149 °F (-25 °C ... +65 °C); Clima class 4 (VDI/VDE 3540)	
Electrical Connections	LF 170	Sensor input: 7-pole AMP socket, IP 66 rating, Outputs, mains supply: via internal plug-in terminal strips
	LF 296	Sensor input, signal inputs and outputs, mains supply: via plug-in terminal strips; accessible from rear
Input power	115/230 VAC (-15/+10%), 48 ... 62 Hz (18 VA max.), 24 VAC (-15/+10%), 24 VDC (-30/+20%)	
Integrated Lightning Protection	Coarse and fine protection, surpasses EN 61326 requirements	
EMI/RFI Conformance	EN 61326 class B, FCC Class A	
Certifications	CE	
Housing	LF 170	Watertight housing (PC/GF20) with threaded receptacle and four cable feed-through connections (PG compression fittings, 10 - 14 mm dia.); Protection rating IP 66 (exceeds NEMA 4X)
	LF 296	Fiberglass-reinforced Noryl housing with membrane keypad (Polyester); Protection rating IP 54 (front panel)
Dimensions	LF 170	8.74 x 7.95 x 4.13 in. (222 x 202 x 105 mm, W x H x D)
	LF 296	3.78 x 3.78 x 7.32 in. (96 x 96 x 186 mm, W x H x D)
Weight	LF 170	Approx. 7.7 lb (3.5 kg)
	LF 296	Approx. 2.2 lb (1 kg)
Guaranty	3 years for defects of quality	

Ordering Information

EcoLine LF 170		Order No.
LF 170, 230 VAC	Conductivity field monitor, 230 VAC 50/60 Hz; standard model	381 112
LF 170 RT, 230 VAC	Same as standard model, with 2 programmable relays and second analog output for temperature	382 212
LF 170 RT RS, 230 VAC	Same as standard model, with 2 programmable relays and second analog output for temperature and RS 485 interface	382 222
QuadroLine® LF 296		Order No.
LF 296, 230 VAC	Conductivity panel mount monitor, 230 VAC; standard model	391 112
LF 296 RT, 230 VAC	Same as standard model, with 2 programmable relays and second analog output for temperature	392 212
LF 296 RT RS, 230 VAC	Same as standard model, with 2 programmable relays and second analog output for temperature and RS 485 interface	392 222

EcoLine LF 170:



QuadroLine® LF 296:



Other power supplies see brochure "Product Details"

① R-T-version, ② R-T-RS-version



Analyzer

On-line Measuring

Water and wastewater treatment still require analyzers for on-line measuring, justifying their presence next to commonly more reasonable in-situ sensor systems. Especially for utmost precise water analysis – with for i.e. effluent monitoring of wastewater plants requiring automatic calibrations and/or adaption as well as standard DIN procedures for analysis – analyzers are applied. Besides the measuring instruments also the sample preparation is of great importance. Sample preparation and measuring system should correspond to each other in order to guarantee failure-free reliable and accurate measurements. The WTW TresCon® analyzer and PurCon® sample preparation represent a perfectly matching complete system and guarantee best possible measuring results even under most difficult conditions.

Measuring parameters

The WTW analyzer cover a wide range of measuring parameters. Besides the nitrogen parameters ammonium, nitrate as well as nitrite also the phosphate parameters ortho-phosphate and total phosphate can be measured by the TresCon® analyzer family. Mainly photometric and potentiometric procedures are used.

Controlling

When the main focus is set on the control/regulation of processes, it is advisable to use in-situ sensors for fast, continuous monitoring of measuring values, whenever possible. In such cases it sometimes becomes acceptable, when measurings are less precise and do not comply with the DIN standard. Only a high process transparency enables to develop efficient controlling strategies. Reliable and

immediately accessible measuring data of all process relevant parameters are precondition for process transparency. This was well exemplarily processed during the last years regarding the optimization of nitrification and denitrification: Through ion-selective in-situ ammonium and nitrate measurements of WTW's VARION®, AmmoLyt®, and NitraLyt® and additionally the spectral in-situ nitrate measurement using NitraVis® sensor did not only improve the nitrogen elimination but also cut costs considerably.

Phosphate parameter

Both measuring parameters ortho-phosphate and total phosphor cannot be determined by ion-selective or spectral measurement. However, analyzer as the currently exclusive automatic measuring instruments enable the determination of both parameters.

For this reason analyzers are so far the only alternative for the total-phosphor measuring – i.e. for wastewater treatment discharge monitoring – and for ortho-phosphate elimination through controlled adding of precipitation solution.

Special applications

Also with special applications and process related difficult applications, analyzers can outperform in-situ measurements. Especially related to contamination problems such as for extremely grease contaminated wastewaters special cleaning liquids can be used for analyzers especially developed for this condition. In-situ measuring sensors the automatic cleaning with cleaning liquids is not given and also not

feasible unless further efforts are undertaken. Also the option to operate the analyzers with sea-water applications such as fishfarming or fishtanks enables the automatic measuring of some parameters, such as ammonium or nitrate, considering that ion-selective or spectral optical methods cannot be applied in those areas.

Sample dilution

Furthermore, analyzers offer the possibility to attenuate the sample using distilled or deionized water and therefore finally enable a measuring with high parameter concentrations.

 General Description
of Meters

IQ SENSOR NET

Monitors

Analyzer

 Sample
Preparation

Samplers

Accessories

TresCon® – Systematic On-line Analysis

For Continuous Monitoring and Process Control

As the need for higher quality measurements in water and wastewater plants increases so does the complexity and degree of automation. Practical and maintenance-free instruments to continuously monitor these processes requires that those instruments be also rugged and efficient. The TresCon® Multi-parameter System exceeds all requirements for accurate and precise continuous measurements.



TresCon®

- Simultaneous analysis of up to three parameters
- Easily upgradeable
- Reliable & Accurate

A Progressive Design – Modular System

The TresCon® 's individual system components, the central control unit and the self-contained analyzer modules, have their own microprocessors which can perform specific tests independently.

The controller and the module communicate via high speed internal connections. Real-time control of the most difficult tests are easily accomplished with the TresCon® 's superior design. System can be custom designed to meet the operator's needs.

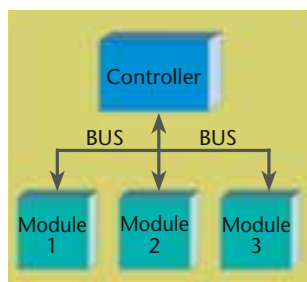

① System Controller Module

Equipped with a fast microprocessor, the controller includes a graphic display unit, a control panel and all the input/output interfaces. The controller inputs all application functions, calibration protocols, processing and storage of data and the display of measured results.

If modules are added or exchanged TresCon® will automatically recognize the new parameter and automatically updates the system. No operator servicing is required.

② Analysis Modules

The analyzer modules are microprocessor-based, self-contained system components which will operate completely independent of each other. Up to three modules, in any combination of parameters, can be integrated into a single TresCon® system. The modules can be for the same parameter from different sample sites, or for any combination of the available parameters.

- NH₄-Module (Ammonium-Nitrogen)
- NO₃-Module (Nitrate-Nitrogen)
- NO₃/SAC-Module (Nitrate-Nitrogen and SAC)
- NO₂-Module (Nitrite-Nitrogen)
- PO₄-Module (Orthophosphate)
- ΣP-Module (Total Phosphorus)

Retrofitting or exchanging a module can be carried out in a few minutes. The new module is automatically recognized by the TresCon® controller and is immediately ready to use.

③ System Mounting

The stainless steel mounting column is an integral part of the TresCon® system. It is used for simple wall mounting and also contains the wide-range power supply for TresCon®.

④ Supplies Tray

A tray holds all bottles and containers for reagent, standard and cleaning solutions. The containers are color-coded so that parameters and connections can be easily connected.



Ammonium-Nitrogen

Nitrate-Nitrogen/SAC



Nitrite-Nitrogen

Orthophosphate



Total Phosphorus

 General Description
of Meters

IQ SENSOR NET

Monitors

Analyzer

 Sample
Preparation

Samplers

Accessories

User Interface

Simple Operation

- Uniform user interface for the complete system
- Uniform operation of all analysis parameters
- Clear and logically structured system program
- Rapid and safe input by 8 function and control keys
- Quick Start Guide/ Instruction Manual



Easy-to-read information and graphical presentation

- High-resolution backlit graphics display
- Up to 3 measuring parameters at a glance
- Clear presentation of measurement, units, individual text and assigned relays and current interfaces
- Daily or weekly trend curves for individual or several parameters in a single graph
- Status line for auxiliary information

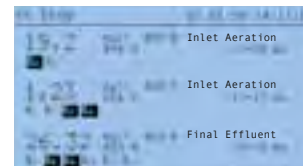

Auto Functions of All Modules

AutoClean®	An innovative method for automatic self-cleaning whose high efficiency allows measurements in slightly polluted wastewater, e.g. in sewage treatment plant effluent, without sample preparation.
AutoCal	Automatic calibration and plausibility check at predefined time intervals – resulting in a higher degree of accuracy.
AutoKorr	A correction algorithm developed by WTW for compensating background color in the sample in photometric measuring methods.
AutoFlow	Function for continuously monitoring the container filling levels and the sample/reagent flow in the module and for producing useful maintenance messages.
AutoTherm	Automatic temperature control means that ambient temperature influences on the analytical results can be disregarded.
Intervall	Software function for regular measurements at selectable intervals.
Intervall-Program	Measuring program – for a period of one week the measuring intervals within two-hour sections can be defined. This allows extremely reagent-saving operation in periods where experience has shown that only slight variations in the measurements are to be expected.

System Inputs & Outputs

TresCon® standard features include a number of analog and digital outputs, which provide enhanced data management and control capabilities of the system. All inputs and outputs can be assigned at will to the installed analyzer modules and freely configured.

Serial Interfaces

Two serial input/output interfaces which can be operated independently are standard equipment in the analyzer. While the RS 232, for example, is linked to a local device for data recording – such as a printer –, the RS 485 interface allows for remote control of the unit.

If a telephone connection is available then TresCon® can be accessed and controlled by a remote computer via the RS 232 interface and a modem. The RS 485 interface also allows TresCon® to be coupled to PROFIBUS-DP by using a gateway.

PID Control

As an alternative to outputting the measured values, the analog outputs of TresCon® can also be used as PID controllers for control and feedback control purposes.

Proportional Control (PW/PF)

As well as being used for report or limit contacts, each relay can also be programmed as an impulse or frequency controller. Depending on the control function, in I/F control either the impulse length (I-control) or the impulse frequency (F-control) of the output signal is varied.

TC/PU 1 Two-Channel Permeate Switcher

By means of the TC/PU 1 Two-Channel Permeate Switcher TresCon® can analyze samples from two different sampling locations in sequence. As the two analyzer samples, e.g. the permeate flows from two PurCon® systems, are directly in contact with the switching valve, any alteration in concentration of either of the permeate flows can be registered within minutes. Up to three TresCon® modules can be con-

nected to the TC/ PU 1 Two-Channel Permeate Switcher. It is available as an accessory and can be mounted on the side of the TresCon® stand in a space-saving manner. Control is via the TresCon® terminal. The mA outputs and relays can be parametrized accordingly so that no additional external reporting units are necessary.

Technical Data TresCon®	
Sample preparation	TresCon® analyzer modules require continuous sample input with a low solids content; typical sample preparation with PurCon® (see Sample Preparation Section).
Sample delivery	Sample presented for analysis in overflow vessels supplied; up to three analyzer modules can be connected to one overflow vessel. Operation with up to three overflow vessels is also possible (parallel analysis of different samples).
Interfaces	3 freely configurable galvanically separated 0/4-20 mA outputs, 12 potential-free relays, freely configurable, RS 232, RS 485.
Electrical connections	230 VAC ±10%, 50 Hz / 115 VAC ±10%, 50 – 60 Hz
Ambient conditions	Storage temperature –77 ... 140 °F (–25 ... 60 °C), operating temperature 32 ... 104 °F (0 ... 40 °C), climate class 4, VDI/VDE 3540 Bl. 2
Test marks	CE, DIN-GOST
Instrument protection	Safety class I according to IEC 1010-1/EN 61010-1
Weight	Empty housing: 59.5 lb (27 kg); each module: 22 lb (10 kg); mounting column: 55 lb (25 kg)
Guaranty	2 years for defects of quality

Ordering Information		Order No.		
Ein TresCon® basic instrument (without module) consisting of:	TresCon® terminal, mounting column, reagent tray, overflow vessels for max. three modules, terminal operating instructions (German) If operating instructions in English are required these must be ordered separately.			
TresCon® basic instrument (with first analyzer module)		1 st Module	2 nd Module	3 rd Module
TresCon® Ammonia, A111	Basic instrument with ON 110 module for Ammonium-Nitrogen	8A-1	<input type="checkbox"/>	<input type="checkbox"/>
TresCon® Nitrate, N211	Basic instrument with ON 210 module for Nitrite-Nitrogen	8A-2	<input type="checkbox"/>	<input type="checkbox"/>
TresCon® Nitrite, N511	Basic instrument with ON 510 module for Nitrite-Nitrogen	8A-3	<input type="checkbox"/>	<input type="checkbox"/>
TresCon® Orthophosphate, P211/MB 1	Basic instrument with OP 210/MB1 module for Orthophosphate (measuring range 1)	8A-4	<input type="checkbox"/>	<input type="checkbox"/>
TresCon® Orthophosphate, P211/MB 2	Basic instrument with OP 210/MB2 module for Orthophosphate (measuring range 2)	8A-5	<input type="checkbox"/>	<input type="checkbox"/>
TresCon® Orthophosphate, P211/MB 3	Basic instrument with OP 210/MB3 module for Orthophosphate (measuring range 3)	8A-6	<input type="checkbox"/>	<input type="checkbox"/>
TresCon® Nitrate/SAC, S211	Basic instrument with OS 210 module for Nitrate-Nitrogen and SAC	8A-7	<input type="checkbox"/>	<input type="checkbox"/>
TresCon® Total Phosphorus, P511	Basic instrument with OP 510 module for Total Phosphorus (requires two module places)	8A-8	<input checked="" type="checkbox"/>	<input type="checkbox"/>
Ordering options for additional analyzer modules (2nd/3rd modules)				
Without additional analyzer module			<input type="checkbox"/>	<input type="checkbox"/>
NH ₄ analyzer module (Ammonia-Nitrogen), OA110			<input type="checkbox"/>	<input type="checkbox"/>
NO ₃ analyzer module (Nitrate-Nitrogen), ON210			<input type="checkbox"/>	<input type="checkbox"/>
NO ₂ analyzer module (Nitrite-Nitrogen), ON510			<input type="checkbox"/>	<input type="checkbox"/>
PO ₄ analyzer module (Orthophosphate), OP 210/MB1			<input type="checkbox"/>	<input type="checkbox"/>
PO ₄ analyzer module (Orthophosphate), OP 210/MB2			<input type="checkbox"/>	<input type="checkbox"/>
PO ₄ analyzer module (Orthophosphate), OP 210/MB3			<input type="checkbox"/>	<input type="checkbox"/>
NO ₃ /SAC analyzer module (Nitrate-Nitrogen and SAC), OS 210			<input type="checkbox"/>	<input type="checkbox"/>
Other ordering options				
Without feet (wall mounting with mounting stand)				<input type="checkbox"/>
With feet (free-standing arrangement)				<input type="checkbox"/>
Please complete the ordering number by entering the required versions:			<input type="checkbox"/>	<input type="checkbox"/>
Ordering example:	TresCon® Ammonium A111 with additional nitrate module, for wall mounting with mounting stand	8A-1	<input type="checkbox"/>	<input type="checkbox"/>



The technical data of the analyzer modules can be found on pages 50 to 69.



TresCon® Uno

- Compact dimensions
- Economical
- Easy to Use

Online-Analysis – reliable · compact · economical

The new TresCon® Uno uses a single channel version of our popular multi channel TresCon® Analyzer. The TresCon® Uno instruments are designed for control and monitoring at waste water treatment plants. The compact size of TresCon® Uno at a reasonable price offers to the user a good price-performance-ratio for the measurement of nutrient parameters.

System Description:

TresCon® Uno consists of a basic unit ①, an analyzer-module ②, and a reagent tray ③. System can be wall mounted.

Operation safe and Service friendly:

Many automatic diagnosis functions help the user with operation and maintenance. The modular design allows for the quick and easy exchange or replacement of modules.



Maintenance and Service

TresCon® systems are service-friendly requiring little or no maintenance. The numerous useful system functions are easily accessed and changed. The operator is also prompted as to service intervals automatically. It has also been designed for easy access and maintenance.

The Instruments include:

- big graphical display
- three 0/4-20 mA outputs
- 12 relay interfaces
- RS 232 interfaces
- RS 485 interfaces
- different controller functions (PID, pulse-width, frequency)

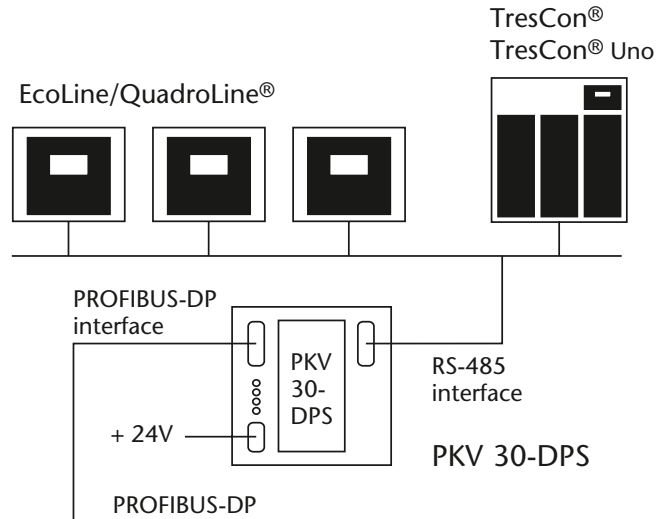

Connection to PROFIBUS-DP via Protocol Converter

Technical Data TresCon® Uno

TresCon® Uno			
Measuring ranges <i>Detailed technical data: see TresCon® modules in parameter section*</i>	Ammonium:	0.05 ... 1000 mg/l NH ₄ -N	<i>*See also OA 110, page 50</i>
	Nitrate:	0.10 ... 60 mg/l NO ₃ -N	<i>*See also ON 210, page 55</i>
	Nitrite:	0.05 ... 1,200 mg/l NO ₂ -N	<i>*See also ON 510, page 56</i>
	Orthophosphate Range 1:	0.05 ... 3,00 mg/l PO ₄ -P	<i>*See also OP 210, page 68</i>
	Orthophosphate Range 2:	0.10 ... 10,0 mg/l PO ₄ -P	<i>*See also OP 210, page 68</i>
	Orthophosphate Range 3:	0.10 ... 25,0 mg/l PO ₄ -P	<i>*See also OP 210, page 68</i>
	Nitrate/SAC:	0.10 ... 60 mg/l NO ₃ -N / 0.10 ... 200 m ⁻¹	<i>*See also OS 210, page 55</i>
Calibration	Automatic 2-point-calibration (works calibration for N211 and S211)		
Measurement intervals	Cont., 5, 10, 15, 20, 25, 30 min to be set depending on the parameter		
Sample preparation	Depending on the application: none, PurCon® or PurCon® IS		
Mains	230 VAC ±10%; 50 Hz / 115 VAC ±10%; 50/60 Hz		
Operation temperature	32 ... 104 °F (0 ... 40 °C)		
Dimensions, Weight (W x H x D, lb/kg)	Analyzer:	24.1 x 30.5 x 13 in. (612 x 775 x 329 mm), approx. 77.2 lb/35 kg	
	Reagent tray:	23.2 x 2 x 14.2 in. (590 x 50 x 360 mm), approx. 37.5 lb/17 kg	
Guaranty	2 years for defects of quality		

Ordering Information

TresCon® Uno			Order No.
TCU/A111	TresCon® Uno – Ammonium	NH ₄ -N	820 101
TCU/N211	TresCon® Uno – Nitrate	NO ₃ -N	820 102
TCU/N511	TresCon® Uno – Nitrite	NO ₂ -N	820 103
TCU/P211-MB1	TresCon® Uno – Orthophosphate Range 1	PO ₄ -P/MB1	820 104
TCU/P211-MB2	TresCon® Uno – Orthophosphate Range 2	PO ₄ -P/MB2	820 105
TCU/P211-MB3	TresCon® Uno – Orthophosphate Range 3	PO ₄ -P/MB3	820 106
TCU/S211	TresCon® Uno – Nitrate/SAC	NO ₃ -N / SAC	820 107

IP 54

2 Year Guaranty



Sample Preparation

On-Line Sample Preparation – Continuous · Reliable · Low Maintenance

Sample preparation is usually necessary for the reliable operation of on-line analyzers in municipal and industrial wastewater treatment facilities. Preparing the sample prevents solids and bacteria from contaminating the analysis system and its components. The sample preparation system and the analysis system must be matched to each other so that accurate and continuous measuring operation can be guaranteed together with low maintenance requirements.

In combination with a suitable sample preparation system, WTW analysis systems provide greater operating reliability and availability.

WTW Sample Preparation Systems

- Biological Treatment

For the most frequent application of on-line analyzers, their use in the biological treatment of wastewater treatment plants, WTW has developed the **PurCon**® sample preparation system. In contrast to preparation techniques based on the sedimentation principle, this low-maintenance system provides a constant flow of permeate.

- Final Effluent

For monitoring final effluent, WTW TresCon® Analyzers require **no sample preparation**. The TresCon®'s AutoClean® feature allows the treated sample to be measured directly.

The new P 700 IQ orthophosphate analyzer requires a special sample preparation, which is only offered for this analyzer. For further information see page 67.

Biological Treatment

PurCon®

- Continuous sample preparation
- Solid-free and bacteria-free permeate
- BubbleClean®, self-cleaning feature – Low Maintenance



PurCon® – the perfect sample preparation

PurCon® is a continuously operating sample preparation system which has been specially designed for use in wastewater treatment facilities. In contrast to conventional preparation systems, e.g. by sedimentation, the PurCon® unit provides a continuous flow of solid-free and bacteria-free permeate; BubbleClean® feature results in low maintenance requirements.

This sample preparation system is suitable for a wide range of applications in the wastewater treatment plants; even for applications in the biological treatment with difficult-to-sediment sludge components.

The PurCon® sample preparation system is the ideal complement to the TresCon® analysis system as up to three on-line analysis modules can be supplied with permeate simultaneously.

In typical applications in municipal wastewater treatment plants, e.g. in the biological tank (3–6 g/l sludge), 6 months maintenance-free operation is possible.

System description

The PurCon® sample preparation system consists of a sample preparation unit and a control unit with peristaltic pump for permeate delivery. The unit is fully mounted and is built into a V4A stainless steel housing with a door in the front panel.

To supply the raw water to the PurCon® system a submersible pump is required; its type and size depend upon the local conditions. Sample discharge is pressureless (outlet diameter > 1.97 in./50 mm).

Technical Data PurCon®

Permeate	Feed to Analyzer	Continuous
	Yield	3.6 l/h max., adjustable in four increments
	Quality	Free of solid matter and bacteria
Sample Delivery	Minimum ... maximum	400 ... 1.500 l/h approx.
Connections	Sample inlet	Hose barb fitting, 3/4" I.D.
	Drain outlet	PVC pipe fitting, 51.97 in. (50 mm) I.D., pressureless
	Rinsing outlet	Hose barb fitting, 3/4" I.D.
	Permeate outlet	Screw fitting, 0.06" dia. (1.54 mm)
Electrical Requirements	Voltage	230 VAC / 115 VAC (depending on version)
	Power consumption	150 VA approx. (without pump)
	EMC	According to EN 62 326 class B, Annex A, FCC class A
Mechanical, Protection Rating	Dimensions (HxWxD)	2.38 x 1.86 x 0.71 ft. (735 x 575 x 220 mm)
	Material	316 stainless steel; IP 33
	Weight	Approx. 79.38 lb (36 kg)
Maintenance Requirements	Municipal applications	Depends on location and wastewater load, typically 20 min / month
Ambient Conditions	Temperature	Storage: –13 ... 140 °F (–25 ... 60 °C) / Operating: 32 ... 104 °F (0 ... 40 °C)
Certification	CE, TÜV-Mark, DIN-GOST	
Guaranty	2 years for defects of quality	

Ordering Information

PurCon®		Order No.
PurCon®/ 230	Sample preparation system for 230 VAC, with 1 m permeate tubing with adapter, 3 hose clamps for feed tubing	810 000
PurCon®/ 115	Sample preparation system for 115 VAC, with 1 m permeate tubing with adapter, 3 hose clamps for feed tubing	810 008



2 Year
Guaranty

PurCon® IS

- Direct in-situ operation
- Continuous sample preparation
- Self-cleaning “BubbleClean®”

Sample Preparation on-site with no external Pumps required

PurCon® IS consists of a filter unit ①, that is put directly in the sample, a suction hose ②, a control unit for outside mounting ③, that takes the permeate in and a permeate line ④ for the transport of the permeate to the analyzer units. The permeate line can – according to the ambient temperature conditions at the site – be specified with or without freeze protection.

At the end of the permeate line a box ⑤, is mounted that delivers the permeate.

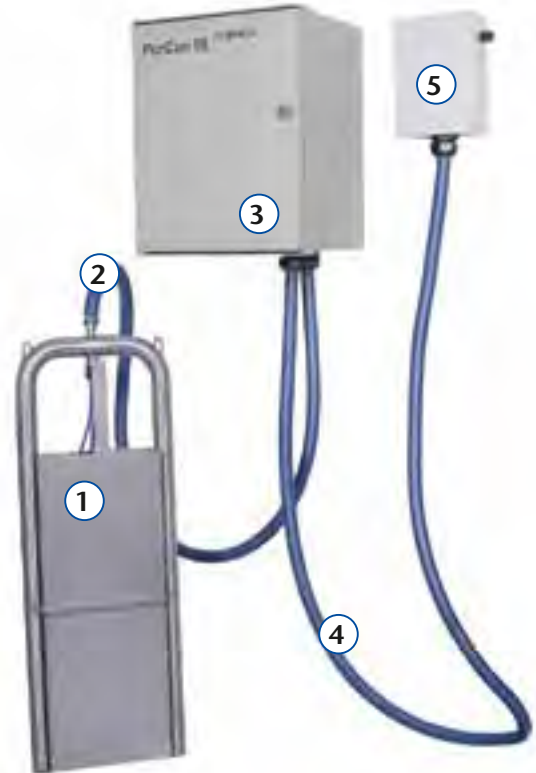

Technical Data PurCon® IS

Permeate Stream Sufficient for	PurCon® IS/2-230: supply of one TresCon® analyzer module PurCon® IS/4-230: supply of up to three TresCon® analyzer modules
Hose Length	Suction hose: 5.47 yds (5 m) Permeate line 5.47, 10.94 or 21.87 yds (5, 10 or 20 m)
Operating Temperature	-4 ... 104 °F (-20 ... +40 °C); with freeze protection
Applications	Suited for outside operation
Mounting	Filter unit: Chain-, railing-, wall-, basin-, column mounting Control unit: railing-, wall mounting In combination with mounting sets and the WTW mounting system
Dimensions (B x H x T, lb/kg), Weight, Protection Rating	Filter unit: 1.04 x 3.03 x 0.23 ft. (321 x 934 x 71 mm), 22 lb (10 kg), IP 68 Control unit: 1.34 x 1.66 x 1.12 ft. (412 x 513 x 345 mm), 33 lb (15 kg), IP 33
Guaranty	2 years for defects of quality

Ordering Information

PurCon® IS		Order No.
PurCon® IS/2-230	PurCon® IS filter unit with 2 filter membranes, 5.47 yds (5 m) suction hose and control unit (230 V AC) for supply of one TresCon® analyzer module	810 050
PurCon® IS/4-230	PurCon® IS filter unit with 4 filter membranes, 5.47 yds (5 m) suction hose and control unit (230 V AC) for supply of up to three TresCon® analyzer modules	810 051
PCIS-Set115	Adaption set to 115 V AC mains supply	810 070
Permeate line – required for operation		Order No.
PCIS-PL5/H	5.47 yds (5 m), with freeze protection	810 065
PCIS-PL10/H	10.94 yds (10 m), with freeze protection	810 066
PCIS-PL20/H	21.87 yds (20 m), with freeze protection	810 067
PCIS-MSK	Set for chain mounting for PurCon® IS filter unit	810 071
PCIS-MSS	Set for bar mounting for PurCon® IS filter unit	810 072
PCIS-MSG	Set for bar mounting for PurCon® IS control unit	810 073



Further Accessories see brochure “Product Details”

Secondary Sedimentation Stage / Final Effluent

In the effluent water from the secondary sedimentation the concentration of solids is often so high that sample preparation is required before on-line analysis can take place. In the effluent from wastewater treatment plant it is possible to carry out on-line analysis with TresCon® without any sample preparation as the analyzer module uses the AutoClean® method; this is a very efficient automatic self-cleaning system.

Final Effluent

If TresCon® analyzers are used in slightly loaded wastewater such as wastewater treatment plant effluent the

- **PF 105 sample bypass** is used to provide the analyzer module with unfiltered sample. The unit consists of a Y-shaped pipe branch with a valve for regulating the flow in the bypass. The supply to the TresCon® analyzer can be set with a second fine valve in the sample branch. To protect the TresCon® analyzer module coarse particles are retained by a woven-wire sieve in the branch.
- **Overflow vessel VB 105** with continuous sample flow is used to feed the analysis modules with non-filtrated sample. The unit is made up of a cylindrical vessel with a volume of approx. 2 l. This vessel is continuously being flown through and thus always supplies up-to-date sample.



PF 105 sample bypass

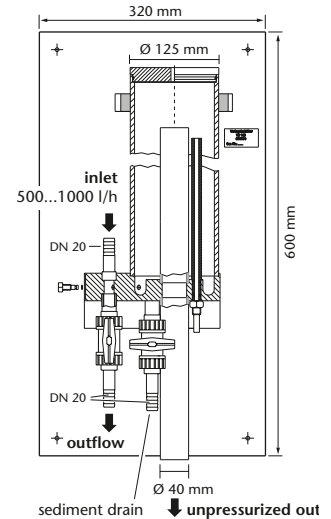

Overflow vessel VB 105

Secondary Sedimentation

PurCon®

Apart from its use in aeration basins, the PurCon® system is ideal for the preparation of samples from the secondary sedimentation stage. In such cases PurCon® also continuously supplies an adequate amount of high-quality permeate. As only residual solids need to be removed from the sample, extremely low maintenance requirements are achieved.

Technical Data PF 105	
Tubing connections	20 mm dia.
Permeate tubing	Length 1.09 yds (1 m), 0.24 in. (6 mm) I.D.
Feed	1000 ... 1500 l/h
Branch	Approx. 3 l/h
Dimensions (H x W)	1.28 x 1.07 ft. (395 x 330 mm)
Ordering Information	
Accessories	Order No.
PF 105	Submersible pump without cutting blade for PurCon®, PF 105 or FPB 000 670
VB 105	Low power submersible pump without cutting blade, power 350 W 830 860

*Pumps are not included in scope of delivery.
Pumps and further Accessories see brochure "Product Details"*



Sampling

Stationary · Portable

Sampling is an important factor for the compliance with required regulations and efficient operation. It forms the basis for continuous monitoring of quality objectives and criteria, in particular for performance analysis of wastewater treatment plants. In addition, sampling systems are used increasingly for managing and optimizing complex production and recycling processes. In this context sampling represents the first link in the chain of work procedures for the examination and analysis of chemical, physical and biological parameters. It thus has a decisive, subsequently irrefutable, influence on results gained from chemical analysis.

Absolutely reliable provision of representative samples is extremely important, as they provide reliable and consistent assessment of contents and water properties.

Sampling

- Sewage Treatment
- Municipal Sewerage Systems
- Water Protection Control

The factors directly connected with sampling (sampling method, sampling location, sampling storage, sampling transport, sampling preservation and the method of analysis itself) have another important influential effect on the result. Consistent and exacting sampling is becoming increasingly significant due to the increase of required regulations.

WTW has added two new units for precise sampling with the PB 8 and the PB 150-SE12 / -SE24. The PB 8 is a compact unit for plant monitoring. PB 150-SE12 / -SE24 is an automatic, self-emptying instrument for process monitoring.

Functionality

Sampling devices work according to the proven vacuum or peristaltic pump principle used in wastewater engineering. The vacuum dosing technology is particularly suitable for continuous stationary sample extraction. As sampling is performed only by means of vacuum or pressure, even heavily polluted wastewater with abrasive contents can be extracted safely and without wear.

In contrast, peristaltic pump technology is particularly suitable for short-term mobile sampling at different measuring locations.

Sampling procedure

Sampling is performed by non-pressurized extraction of either a single sample, a qualified sample, a 24 h composite sample or a 2 h composite sample from a lower level, e.g. from a basin, open channel or pipe under the following conditions:

Time

Constant sample volume, constant sampling frequency

Amount

Constant sample volume, sampling frequency variable according to throughput volume (0/4-20 mA or flow impulse)

Flow

Sample volume variable according to throughput volume (0/4-20 mA or flow impulse), constant sampling frequency

Event

Constant sample volume, constant sampling frequency, Constant sample filling time or individual samples per bottle

Combination mode

Optional combination of time, amount and event sampling operation

Technical Data Samplers

Sampling
Mains operated



	PB 8	PB 150-2	PB 150-SE
Applications/ Specific Features	Simple robust device for plant monitoring in water and wastewater Wall / Control panel mounting	Proven system for process and wastewater engineering, even for larger polluting load; Frame mounting	System for continuous, unmanned, "around the clock" monitoring. For process and water monitoring measuring networks. Self-emptying; Frame mounting
Installation Site			
Permanent measuring place outdoor installation	—	●	●
Frost-free roofed installation	●	—	—
Sample Storage			
Thermostatic control / cooling heating	—	●	●
Passive cooling (IsoBox)	Option	—	—
Sampling Method			
Vacuum system	●	●	●
Vacuum system Var	—	Option	Option
Self-emptying	—	—	●
Sampling Method			
Time	●	●	●
Amount	●	●	●
Flow volume	—	Option	Option
Event	●	●	●
Combination mode	●	●	●
Communication			
Modem/GSM	—	Option	Option
RS 232	—	●	●
System message display	—	●	●
System messages / signal outputs	—	Option	Option
Sample Fractioning/Composite Sample			
Storage tanks 25 l	●	●	—
Storage tanks 50 l	●	●	—
12 x 1.1 l	IsoBox	—	—
2 x 10 l, 4 x 6 l	—	●	—
4 x 14 l, 4 x 10 l	—	●	—
12 x 2.9 l	—	●	—
12 x 2 l glass	—	●	12 x 1,6 l glass
24 x 1 l	—	●	—
24 x 1 l glass	—	●	—
24 x 2 l glass	—	—	Option
Guaranty	2 years for defects of quality	2 years for defects of quality	2 years for defects of quality



**Sampling
Mobile Operation**

	PB 25 S/PB 25 S/24	PB 13	PB 17
Applications/ Specific Features	Compact design for mobile water and wastewater plant monitoring	Modular system for mobile process and wastewater engineering tasks, even for large polluting load	Compact system with large sample capacity for examination series and load determination in the field
Installation Site			
Frost-free roofed installation	●	●	●
Power consumption			
Battery	●	●	● pluggable
Power supply/recharger	external / buffer operation	external / buffer operation	external / buffer operation
Sample Storage			
Passive cooling (cooling accu.)	—	IsoBox	●
Sampling System			
Vacuum system	—	●	●
Peristaltic pump system	●	—	—
Sampling Method			
Time proportional	●	●	●
Amount proportional	●	●	●
Flow volume proportional	●	—	—
Event proportional	●	●	●
Combination mode	●	●	●
Communication			
Modem/GSM	—	Option	Option
RS 232	Option	●	●
System message display	●	●	●
Sample Fractioning/Composite Sample			
Storage tanks 10 l PE	Option	●	Option
Storage tanks 13 l PE	—	—	—
Storage tanks 25 l PE	● (26 l)	—	—
2 x 5 l PE	—	—	—
12 x 0.5 l glass	Option	—	—
12 x 1,1 l PE	Option	—	—
12 x 1 l glass	—	—	—
24 x 1 l PE	Option	Option	●
Guaranty	2 years for defects of quality	2 years for defects of quality	2 years for defects of quality

Samplers for use in hazardous areas on request.

Stationary Samplers

PB 8

- Vacuum system
- Continuous adjustment of sample volume
- Optional signal output for IsoBox / distributor

Sampler PB 8 for plant monitoring

Device system equipped with vacuum technology for frost-free roofed installation with mains supply. This robust and compact instrument contains proven components and is easy to operate. Controls were reduced to an absolute minimum. The operator guidance is menu driven showing all relevant parameters in the display. Thus providing a system



which is fully sufficient for a multitude of tasks at a very favorable price-performance ratio. The addition of the IsoBox and cable connection accessory components provides the user with an inexpensive version for 2 h composite samples. With this powerful and reliable device, the operator has a low cost sampling instrument at his disposal which is reduced to core functionalities.

PB 150-2

- Vacuum system for operational safety, low maintenance
- Sampling traceability through data memory and interface mode
- Optional flow proportional Var unit

The instruments of the PB 150-2 series with their numerous versions are stationary samplers for permanent outdoor use under rough ambient conditions. The instruments are equipped with low maintenance and self-cleaning vacuum technology which has been field-tested and proven over years in the wastewater engineering sector. The devices are a further development of the PB 150 series and offer even more powerful and more economical sample storage with complete stainless steel fitting and a technically optimized temperature control system with a forced-ventilation liquifier. With its independent operation from the control system, the multiple point regulation system for cooling and heating the sample storage unit offers safe temperature control, even when the control system is turned off. In the light of representative samples for subsequent analysis combined with water content



assessment, thermostatic control plays an important role. With its overall maintenance- and service-friendly equipment configuration with separate energy, control and wet area and its variable control system with memory for user programs, the device offers a high degree of efficiency and availability. The "Var" version with a variable dosing container is available for users who wish to combine flow proportional sampling with the advantages of vacuum technology. This patented version guarantees a reproducible sampling volume which corresponds to the individual flow volume (0/4 - 20 mA) and permits digital sampling volume adjustment.

Sampling can be traced using the display or fully documented and programmed using the communication software which is linked to a PC by an interface.

PB 150-SE

- Vacuum technology for operational safety
- Sampling traceability through program memory
- System monitoring

For permanent stationary use in water and wastewater monitoring measuring networks, automatically self-emptying samplers are available from the PB 150-SE 12 series equipped with 12 or PB 150-SE 24 equipped with 24 sample vessels. These devices operate with proven low maintenance and self-cleaning vacuum technology. The sample vessels are available in glass (Duran 50) and are easily extractable for cleaning. The bottle is sealed and emptied by means of robust constriction hose valves. The fractioned sample in the device is automatically discarded (emptied) or manually extracted for analysis. Immediately after emptying a sample which is no longer required, the relevant bottle is rinsed with pressurized clean water before it is refilled. These devices can store up to 12/24 reserve samples without supervision. In case of serious disruption of operation or other events, event samples can be taken. The PB 150-SE devices are thus not only suitable for “around the clock sampling” for routine monitoring tasks, but also for event sampling or for a combination of both. Sampling is traceable by means of the program and error memory readout on the display or can be documented and programmed from a PC using the communication software.

 General Description
of Meters

IQ SENSOR NET

Monitors

Analyzer

 Sample
Preparation

Samplers

Accessories

Ordering Informations Stationary Samplers

Stationary Samplers		Order No.
PB 8-230 V	Compact sampler 230 V/50/60 Hz for wall mounting	000 180
PB 8-115 V	Compact sampler 115 V/50/60 Hz for wall mounting	000 181
PB 150-2/1	Sampler with thermostatic control for outdoor installation (25 l storage container), 230 V 50/60 Hz	000 190
PB 150-2/R12	Sampler with thermostatic control for outdoor installation (12 x 2.9 l), 230 V 50/60 Hz	000 191
PB 150-SE/12	Sampler, self-emptying, with 12 glass bottles (12 x 1.6 l), 230 V 50/60 Hz	000 188
PB 150-SE/24	Sampler, self-emptying, with 24 glass bottles (24 x 2 l), 230 V 50/60 Hz	000 193

2 Year
Guaranty

Device alternatives and additional accessories see brochure “Product Details”

Portable Samplers

PB 13

- Low maintenance vacuum system
- Large number of sample cycles with just one battery charge
- Sampling is traceable on display

Portable sampler PB 13 with vacuum technology for universal applications. Thanks to its energy saving functionality, a large number of sample cycles or comprehensive sampling programs, respectively can be performed with just one battery charge. PB 13 can be mounted directly on all common storage containers or onto the IsoBox, which is available in different versions. When combined with IsoBox, it provides the user with a practical and modularly extendable system with passive cooling. IsoBox is not only suitable for temperature control of samples but also for safe protected sample transport.



PB 17

- Energy saving vacuum technology
- Very compact build
- Large bottle capacity

The portable sampler PB 17 with vacuum technology and its immensely compact build is also suitable for field use in difficult terrain. With its large utilizable sample capacity of 24 x 1 l segment bottles, it is particularly suitable for extensive monitoring tasks and load determination. The lower part of the device has a double-wall insulation and offers full sample protection and a passive cooling facility with dry ice or cold storage accumulators. The cover, which is equipped with a lock, offers protection against the elements and unauthorized access. Its easy-to-change rechargeable battery with plug connection prevents downtimes caused by battery charging and facilitates a high level of availability.



PB 25 S / PB 25 S/24

- Compact
- Time, amount, event and flow proportional and combined sampling
- Precise non-contacting water measurement (optional)
- Already starting with 5 ml dosing volume

Portable sampler PB 25 S with peristaltic-pump dosing system and integrated rechargeable battery for collected samples 26 l as well as fractioned samples via turnable distributor on 12 x 1 l, 24 x 0.5 l or 24 x 1 l sample containers. Thanks to the linked non-contacting water recognition (optional) also waters with considerably low or high conductivity can be precisely sampled.

Ordering Information Portable Samplers

		Order No.
PB 13		000 184
PB 13	Portable microprocessor-controlled liquid sampler with vacuum dosing system and built-in rechargeable battery. Delivery includes 5 m suction tubing, screw fitting and tubing end piece. Not included: battery charger, sample containers or IsoBox. The required accessories for PB 13 must be ordered separately.	000 186
PB 17		000 103
PB 17	Portable microprocessor-controlled liquid sampler in plastic housing with vacuum dosing system and built-in rechargeable battery. Delivery includes 5 m suction tubing, screw fitting, tubing end piece and 24 x 1 l PE sample bottles. Not included: battery charger. The required accessories for PB 17 must be ordered separately	000 105
PB 25 S and PB 25 S/24		000 103
PB 25 S	Portable sampler with peristaltic pump dosing system, built-in rechargeable battery and battery charger as well as turntable distributor for 12 sample vessels. Supplied with 2 x 2 m suction tubing with quick-release coupling, suction piece and wastewater cap. Not included: sample containers (must be ordered separately, for 12 x 0.5 l glass bottles insert EW/25/0.5 is also required)	000 105
PB 25 S/24	Portable sampler with peristaltic pump dosing system, built-in rechargeable battery and battery charger as well as turntable distributor for 24 sample vessels. Supplied with 2 x 2 m suction tubing with quick-release coupling, suction piece and wastewater cap. Not included: sample containers (must be ordered separately)	000 105

2 Year
Guaranty

Additional accessories see brochure "Product Details"



Accessories

Practical and Functional Components

For optimal configuration of the monitoring station, the instruments are supplemented by an extensive range of mechanical installation and assembly aids and useful accessories. These functional and practical tools provide the user with tailor-made and well thought-out solutions for almost every application.

All mechanical system components are manufactured from corrosion resistant materials. They are easy to assemble and completely maintenance free. The modular concept and the large design variety facilitate trouble-free adaption to the specific application requirements and installation circumstances.

Accessory scheme

- Junction boxes
- Sensor extension assemblies
- Mounting hardware
- Flow-thru adapters
- Valve Assemblies
- Cleaning Systems

Junction Boxes **Analog**

KI/S

Order No.: 108 606

This passive junction box is used for extension cabling between WTW sensors and the EcoLine and QuadroLine® series monitors.

KI/pH 170

Order No.: 108 596

Junction box with integrated impedance converter is designed to connect high impedance pH electrodes to WTW pH monitors over relatively long distances of up to 330 ft (100 m).

Sensor extensions **Analog & Digital**

The universal extension assemblies made of PVC are used for mounting and mechanically protecting all 650, 690, 70X and 70X IQ series WTW sensors. The extension assemblies are available with two different standard lengths of armor; special armor lengths can be defined in your order. The assemblies are supplied with a stainless steel handle and a set of seals.

UA 55

Order No.: 109 260

Armored length without sensor 12.48 in. (317 mm).

UA 130

Order No.: 109 261

Armored length without sensor 42.01 in. (1067 mm).

UA-SO

Order No.: 109 263V

Armored length without sensor:
stepless selectable between 9.45 and 102.36 in.
(240 - 2600 mm).

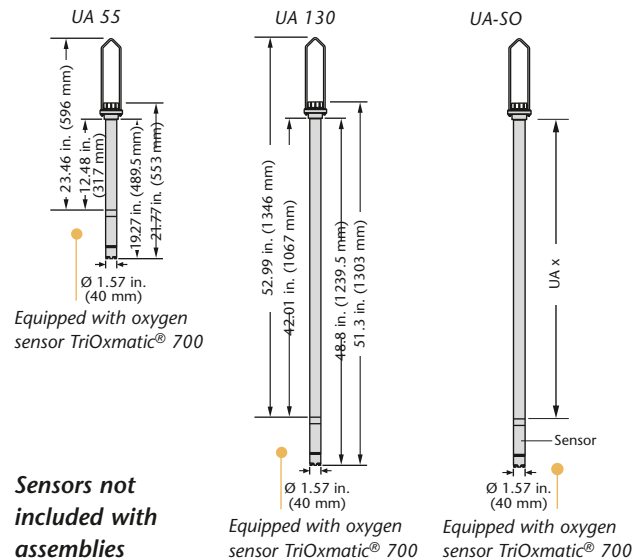

Sensor holders **Analog & Digital**

EH/U 170

Order No.: 109 320

Single sensor holder

EH2/U 170

Order No.: 109 323

Twin sensor holder

EH3/U 170

Order No.: 109 325

Triple sensor holder

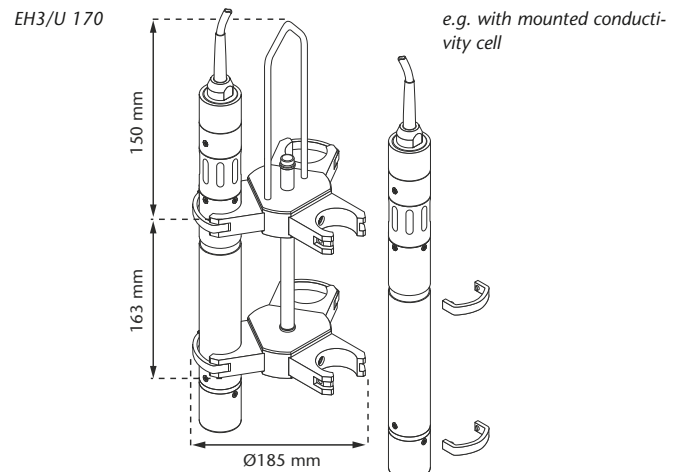

Mounting Hardware

Installation Flexibility

The WTW mounting hardware constitutes a flexible mechanical system in which the individual components are optimally matched. With the selection and combination of various sensor holders, mounting stands and fastening elements, tailor made solutions can be established for the appropriate configuration of the measuring stations; as the diagrams show.

Measurements in Basins

Recommended sensor holding device:
Swing mounting assembly

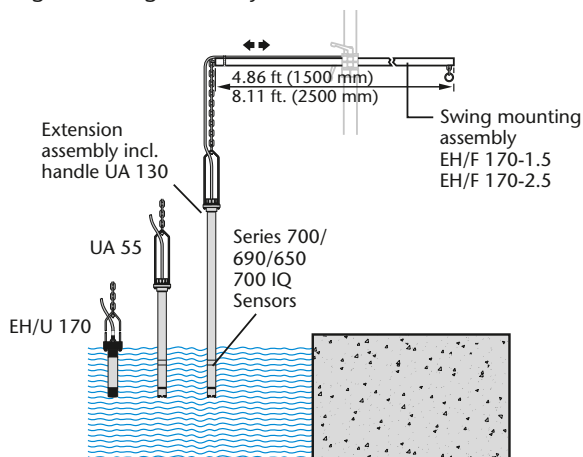

Measurements in Open Channels

Recommended sensor holding device:
Pendulum assembly

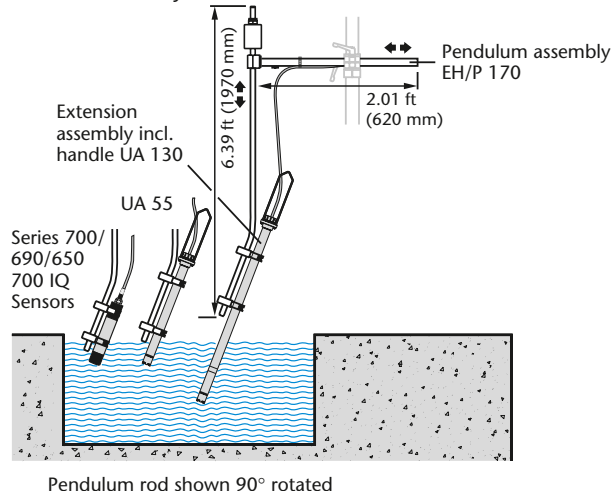

Measurements in Basins or in Open Channels

Wall mounting
for universal extension assemblies UA 55/ UA 130

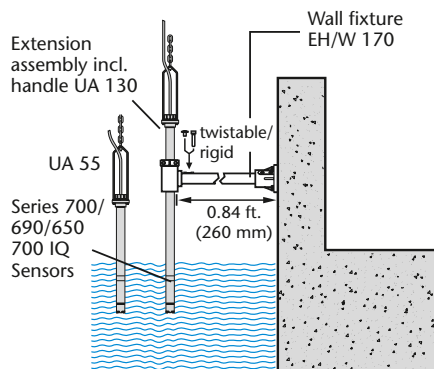

Measurements in very variable water levels or in rivers, lakes, etc.

Sensor Float S 200

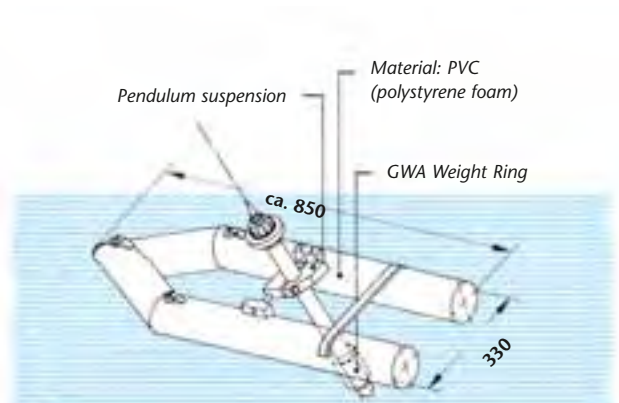

Mounting Stands and Fixtures

Details see page 128/129

Floor Mounting Stand

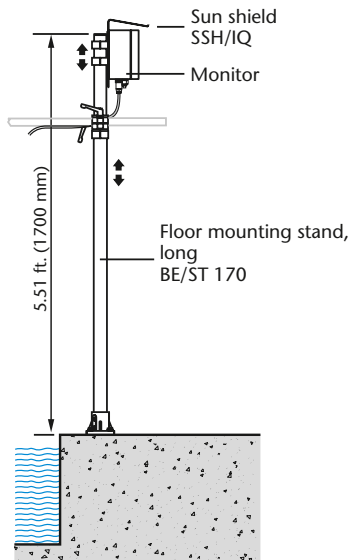

Handrail Mounting (swivel-mounted)

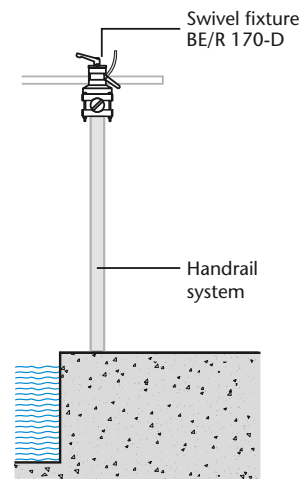

Top-of-Wall Mounting

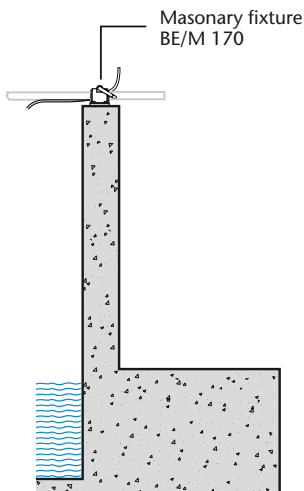

Wall Mounting

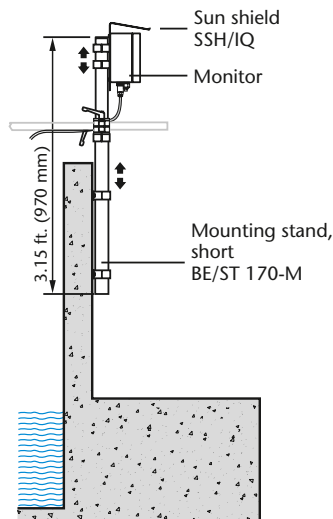

Pipe Mounting

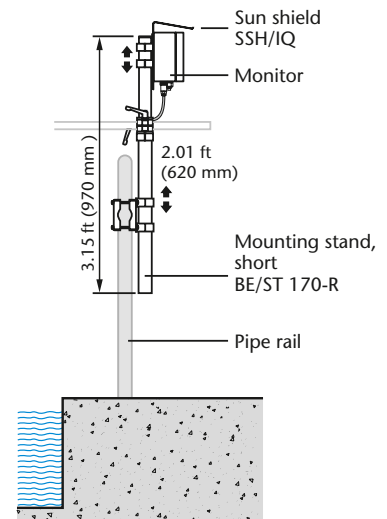

Sensor Holding Devices

EH/F 170

Order No.: 109 272, 109 273

The SensoClean swing mounting assembly consists of a 4.86 ft. or 8.11 ft. (1.5 or 2.5 m) long boom and a 13 ft. (4 m) long plastic chain for height adjustment of the sensor. It may also hold sensor extension assemblies. Particularly in turbulent flows, the freely swinging suspension produces a self-cleaning effect of the sensor, making the swing mounting especially suitable for operation in basins; e.g. in the aeration tank of a wastewater treatment plant.

Boom length	4.86 ft. or 8.11 ft. (1.5 or 2.5 m)
Material	Stainless steel 1.4301
Chain material	Polyethylene

VIS Set/EH

Order No.: 481 073

Supplemental kit for horizontal mounting of a UV(-VIS)-sensor (NitroVis®, CarboVis®, NiCaVis®). Suitable for basin or channel mounting in combination with swing mounting assembly EH/F 170.

Chain material	Polyethylene
-----------------------	--------------

EH/P 170

Order No.: 109 270

The SensoClean pendulum mounting assembly consists of a boom with a pendulum head and an angled pendulum rod. It is fitted at the top end with a movable counterweight for fine adjustment. The sensor or the extension assembly is fastened to the pendulum rod by two pipe clamps.

Boom	Length 2.01 ft. (620 mm), stainless steel 1.4301
Pendulum rod	Length 6.39 ft. (1970 mm), stainless steel 1.4301
Pendulum head, clamp	POM/Polyethylene

Vario Mounting Stand

BE/ST 170

Order No.: 109 280

Robust floor mounted stand made of stainless steel, with joint-locking fixture to accommodate a swing or pendulum mounting assembly and 2 pipe brackets for attaching a sun shield. With diecast aluminum baseplate, wall plugs and screws.

Stand	Length 5.51 ft. (1700 mm), diameter 1.97 in. (50 mm)
Material	Stainless steel 1.4301
Brackets	Polypropylene

EH/W 170

Order No.: 109 274

The EH/W 170 mounting assembly is designed for direct fastening to a wall of a basin. It can be set for pendulous or rigid operation, and it is suitable for extension assemblies. The immersion depth is adjusted by means of a fixing ring. Includes mounting plate with appropriate wall anchors and screws.

Boom	Length 0.84 ft. (260 mm), stainless steel 1.4301
Pendulum head	POM
Mounting plate	Diecast aluminum

S 200

Order No.: 108 540

The float with pendulum mounting assembly is available for use in flowing water or where the water level fluctuates considerably. The fixture is designed for extension assembly UA 55.

A GWA weight ring is also required.

Dimensions	2.76 x 1.07 ft. (850 x 330 mm) (L x W)
Material	PVC

VIS Set-F

Order No.: 481 080

Supplemental kit for horizontal mounting of a UV(-VIS)-sensor (NitroVis®, CarboVis®, NiCaVis®). Particularly suitable for heavily fluctuating water levels in combination with the S 200 electrode float.

Material	PVC/POM
-----------------	---------

BE/ST 170-M

Order No.: 109 283

Mounting stand similar to model BE/ST 170, but shorter version for wall mounting. Wall mounting material is included instead of the baseplate.

Stand	Length 3.15 ft. (970 mm), diameter 1.97 in. (50 mm)
Material	Stainless steel 1.4301

BE/ST 170-R

Order No.: 109 281

This stand is similar to model BE/ST 170, but with hardware for fastening of the stand to a vertical or horizontal pipe rail.

Stand	Length 3.15 ft. (970 mm), diameter 1.97 in. (50 mm)
Material	Stainless steel 1.4301

Fixtures

BE/R 170

Order No.: 109 278

With the BE/R 170 clamp set, a swing or pendulum mounting assembly can be fixed directly to a pipe; e.g. a handrail.

Material	Stainless steel 1.4301/diecast Al/POM
-----------------	---------------------------------------

BE/R 170-D

Order No.: 109 279

The swivel/pivot clamp fixture provides secure connection of a swing or pendulum mounting assembly to a horizontal pipe rail.

Material	Stainless steel 1.4301/diecast aluminum
-----------------	---

MR/SD 170

Order No.: 109 286

Mounting kit for sun shields, suitable for horizontal or vertical pipe rails with diameters of 0.98 to 2.36 in. (25 - 60 mm). Sun shield not included.

Material	Stainless steel 1.4301
-----------------	------------------------

BE/M 170

Order No.: 109 276

With the BE/M 170, a swing or pendulum mounting assembly can be inexpensively installed directly at the basin edge or on top of a wall. It consists of a flange clamp with a clamping lever and a bolt-on base plate.

Material	Stainless steel 1.4301/diecast Al/POM
-----------------	---------------------------------------

BE/M 170 D

Order No.: 109 275

Wall mounting similar model BE/M 170, but pivoting version.

Material	Stainless steel 1.4301/diecast Al
-----------------	-----------------------------------

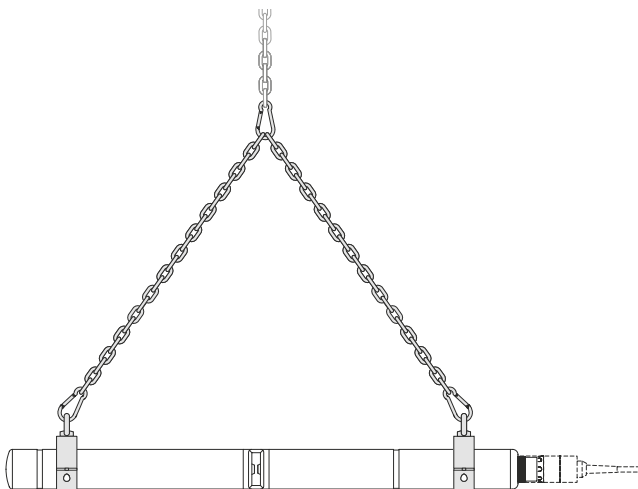

VIS Set/EH

Sun Shields

SD/M 170-D

Order No.: 109 287

Stainless steel double sun shield for parallel mounting of 2 series 171, 170 measuring transducers and IQ SENSOR NET.

Dimensions	10.55 x 21.42 x 5.91 in. (268 x 544 x 150 mm) (H x W x D)
Material	Stainless steel, 1.4301

SD/K 170

Order No.: 109 284

Sun shield for mounting a junction box or an IQ SENSOR NET module in the open air. Mounting kit MR/SD 170 is additionally required for attachment to vertical or horizontal pipes.

Dimensions	5.59 x 9.06 x 3.43 in. (142 x 230 x 87 mm) (H x W x D)
Material	Stainless steel, 1.4301

SSH/IQ

Order No.: 109 295

Sunshield for mounting series 171, 170 and IQ SENSOR NET monitors on a Vario Mounting Stand.

Dimensions	13.03 x 13.54 x 9.45 in. (331 x 344 x 240 mm) (H x W x D)
Material	ASA (Dust gray color)



IQ SENSOR NET under sun shield SSH/IQ

Flow-thru Adapters

	Flow-thru Vessels									
	D 700/N Flow-thru vessel Order No. 203 745	D 702/N Flow-thru vessel Order No. 203 747	DMS/N Flow-thru vessel Order No. 203 749	EBS 700-DU/N Flow-thru adapter Order No. 203 751	EBST 700-DU/N Flow-thru adapter Order No. 203 753	EBST 700-DU/ND Flow-thru adapter Order No. 203 754	ESS 700 VA/N Welding socket Order No. 203 755	ESS 700 VA/10 * Welding socket Order No. 203 757	WA 700/2 Retractable armature Order No. 480 102	WA 700/10 * Retractable armature Order No. 480 100
TriOxmatic® 690/700/ 700 IN/701/ 702 **	ADA-DF3 203 765	ADA-DF4 203 767 and ADA-DF5 203 769	ADA-DF3 203 765	ADA-DF8 203 775	ADA-DF8 203 775		ADA-DF8 203 775	ADA-DF12 203 783	ESS-WA 700/X 480 10X ADA-WA2 480 110	ESS-WA 700/X 480 10X ADA-WA2 480 110
TetraCon® 700	ADA-DF3 203 765		ADA-DF3 203 765	ADA-DF8 203 775	ADA-DF8 203 775		ADA-DF8 203 775	ADA-DF12 203 783	ESS-WA 700/X 480 10X ADA-WA2 480 110	ESS-WA 700/X 480 10X ADA-WA2 480 110
SensoLyt® 650/690/700	ADA-DF2 203 763		ADA-DF10 203 779	ADA-DF10 203 779	ADA-DF10 203 779		ADA-DF10 203 779	ADA-DF13* 203 785	ESS-WA 700/X 480 10X ADA-WA3 480 112	ESS-WA 700/X 480 10X ADA-WA3* 480 112
VisoTurb® 700 IQ			ADA-DF7 203 773	ADA-DF9 203 777	ADA-DF9 203 777	ADA-DF9 203 777	ADA-DF9 203 777	ADA-DF11 203 781	ESS-WA 700/X 480 10X ADA-WA1 480 108	ESS-WA 700/X 480 10X ADA-WA1 480 108
ViSolid® 700 IQ			ADA-DF7 203 773	ADA-DF9 203 777	ADA-DF9 203 777	ADA-DF9 203 777	ADA-DF9 203 777	ADA-DF11 203 781	ESS-WA 700/X 480 10X ADA-WA1 480 108	ESS-WA 700/X 480 10X ADA-WA1 480 108
TetraCon® 700 IQ	ADA-DF1 203 761		ADA-DF1 203 761	ADA-DF9 203 777	ADA-DF9 203 777		ADA-DF9 203 777	ADA-DF11 203 781	ESS-WA 700/X 480 10X ADA-WA1 480 108	ESS-WA 700/X 480 10X ADA-WA1 480 108
SensoLyt® 700 IQ	ADA-DF1 203 761		ADA-DF1 203 761	ADA-DF9 203 777	ADA-DF9 203 777		ADA-DF9 203 777	ADA-DF11* 203 781	ESS-WA 700/X 480 10X ADA-WA1 480 108	ESS-WA 700/X 480 10X ADA-WA1* 480 108
TriOxmatic® 700 IQ/ 701 IQ	ADA-DF1 203 761	ADA-DF4 203 767 and ADA-DF6 203 771	ADA-DF1 203 761	ADA-DF9 203 777	ADA-DF9 203 777		ADA-DF9 203 777	ADA-DF11 203 781	ESS-WA 700/X 480 10X ADA-WA1 480 108	ESS-WA 700/X 480 10X ADA-WA1 480 108
TriOxmatic® 702 IQ		ADA-DF4 203 767 and ADA-DF6 203 771		ADA-DF9 203 777	ADA-DF9 203 777		ADA-DF9 203 777	ADA-DF11 203 781	ESS-WA 700/X 480 10X ADA-WA1 480 108	ESS-WA 700/X 480 10X ADA-WA1 480 108
FDO® 700 IQ	ADA-DF14 203 787		ADA-DF1 203 761	ADA-DF15 203 789	ADA-DF15 203 789		ADA-DF15 203 789	ADA-DF11 203 781	ESS-WA 700/X 480 10X ADA-WA4 480 114	ESS-WA 700/X 480 10X ADA-WA4 480 114
AmmoLyt® Plus 700 IQ NitroLyt® Plus 700 IQ VARiON® Plus 700 IQ	ADA-DF1 203 761		ADA-DF1 203 761	ADA-DF9 203 777	ADA-DF9 203 777	ADA-DF9 203 777				

ADA-DFX

Configuration recommended

Configuration possible (check sensor specs and application)

Configuration not intended

* with electrode SensoLyt® SEA-HP

** only for flow-thru vessel D 702/N

Sensor to be built in	Flow-thru Vessels	
	EBST/SW Flow-thru adapter Order No. 203 758	EBST-D/SW Flow-thru adapter Order No. 203 759
VisoTurb® 700 IQ SW	ADA-DF9/SW 203 790	ADA-DF9/SW 203 790
ViSolid® 700 IQ SW	ADA-DF9/SW 203 790	ADA-DF9/SW 203 790
TetraCon® 700 IQ SW	ADA-DF9/SW 203 790	
SensoLyt® 700 IQ SW	ADA-DF9/SW 203 790	
TriOxmatic® 700 IQ SW	ADA-DF9/SW 203 790	
FDO® 700 IQ SW	ADA-DF9/SW 203 790	

ADA-DFX	Configuration recommended
	Configuration possible (check sensor specs and application)
	Configuration not intended

Flow-thru adapters and flow-thru vessels

WTW accessories can also be used for the IQ SENSOR NET series. By the selection of a suitable adapter all the previous and new WTW sensors of the 690 and 70X (IQ) series can be mounted in the existing flow-thru adapters and vessels.

Flow-thru Vessels

Oxygen Flow-Thru Measurement

D 702/N

Order No.: 203 747

In principle the flow-thru vessel D 702/N for continuous oxygen measurement can be fitted with all TriOxmatic® sensors of the 690/70X (IQ) series. However, it is primarily intended for oxygen measurements in the ppb range (TriOxmatic® 702 IQ), e.g. boiler feed water. In this application the flow-thru vessel is usually installed in the bypass of a water circulation system. Please select an adapter from the table (see page 130/131).

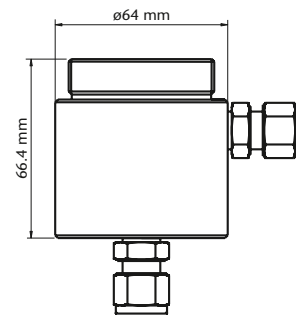

D 702/N

UV-VIS sensors in flow-thru measurement

VIS FT-1

Order No.: 480 080

Flow-thru cell for UV/VIS sensors NitraVis®/CarboVis® and NiCaVis® 700 IQ (TS).

The sensor can be cleaned automatically in mounted state by means of compressed air.

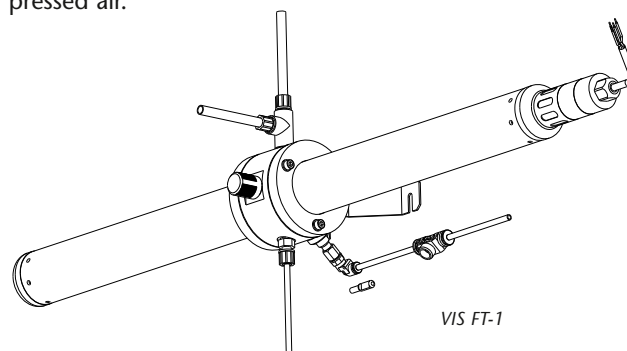

VIS FT-1

Technical details and further flow-thru vessels see brochure "Product Details".

Flow-thru adapters

EBST 700-DU/N and EBST 700-DU/ND

Order No.: 203 753

Order No.: 203 754

Flow-thru adapter for measurements in pipelines, consisting of a 45° PVC T-piece (d 63 DN 50) with bonded sleeve, O-ring seals and union nut. The adapter must be completed by the selection of a suitable sensor flange from the table on page 114 and can then be used for measurement of pH, oxygen, temperature and conductivity with all current WTW sensors.

EBST 700-DU/ND additionally features a compressed-air connection for cleaning installed sensors. Selection of sensors acc. table on page 130/131.

Max. pressure	3 bar (EBST 700-DU/N) or resp. 0.2 bar (EBST 700-DU/ND)
Max. temperature	122 °F (50 °C)
Material	PVC/POM

EBS 700-DU/N

Order No.: 203 751

Mounting set for flow-thru measurements, consisting of a bonded sleeve for standard 45° PVC T-pieces (d 63 DN 50) or other suitable pipeline systems, one R 2" union nut and the necessary O-ring seals. Please select an adapter from the table on page 130/131.

Max. pressure	3 bar
Max. temperature	122 °F (50 °C)
Material	PVC/POM



ESS 700 VA/10

ESS 700 VA/N

Order No.: 203 755

Stainless steel weld-in socket, for measurements in pipelines. Please select an adapter from the table on page 130/131.

Max. pressure	3 bar
Max. temperature	122 °F (50 °C)
Material	Weld-in socket V4A stainless steel 1.4571 Union nut PVC/-U
Total length	5.59 in. (142 mm)
Outside diameter	2.36 in. (60 mm)

ESS 700 VA/10

Order No.: 203 757

Stainless steel weld-in socket, for measurements in pipelines. Please select an adapter from the table on page 130/131.

Max. pressure	10 bar
Max. temperature	140 °F (60 °C)
Material	Weld-in socket V4A stainless steel 1.4571 Union nut V4A stainless steel 1.4571
Total length	5.59 in. (142 mm)
Outside diameter	2.36 in. (60 mm)

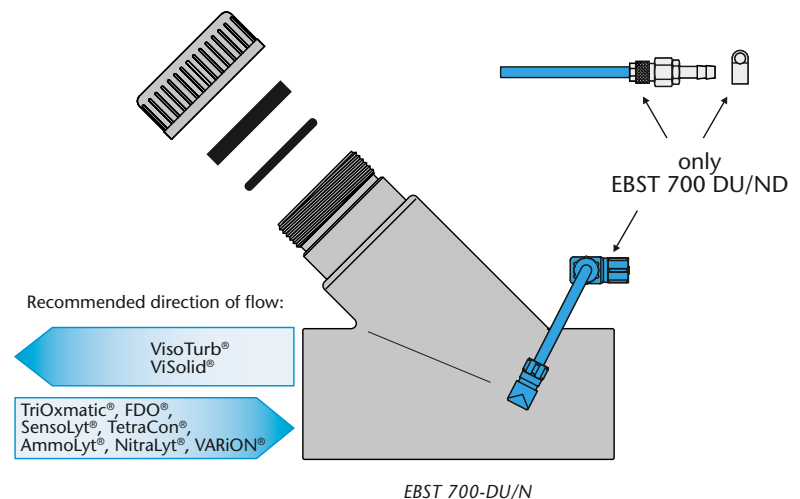

Flow-thru adapters for all sensors in the seawater version of Series 700 IQ SW / 701 SW IQ, see brochure "Product Details".

Retractable Armatures

- For pressurized applications up to 10 bar (overpressure)
- Insertion and removal of sensor during ongoing operation
- With compressed-air cleaning (optional)

Online measurements, of suspended solids in particular, are increasingly performed directly in pipework or pressurized containers. Retractable armatures are used in order to enable assembly and removal of sensors during ongoing operation without interrupting the process. Depending on working pressure, these require suitable assembly aids in order to re-insert the sensor against the working pressure.



The universally applicable structure is as follows:

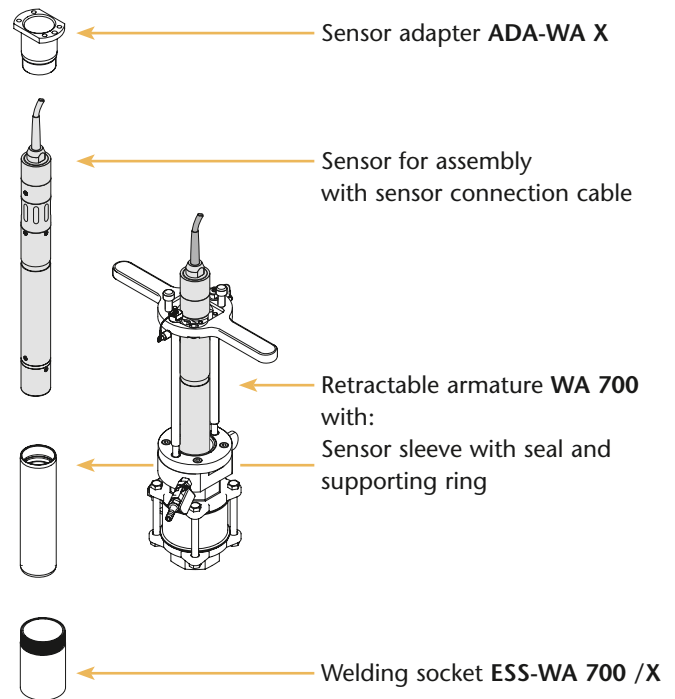

Apart from the two retractable armatures (for various pressure ranges) there are two different welding sockets (steel or stainless steel) and different matching adapters for mounting of the various online sensors with a shaft diameter of 1.57 in. (40 mm) available.

Ordering Information

Sensor adapter		Order No.
ADA-WA 1	Adapter for mounting of IQ sensors	480 108
ADA-WA 2	Adapter for mounting of TriOxmatic® 690/70X, CellOx® 700 and TetraCon® 700	480 110
ADA-WA 3	Adapter for mounting of pH/ORP sensor assembly SensoLyt® 690/700	480 112
Retractable Armatures		Order No.
WA 700/10	Retractable armature for measurements in pipework, up to 10 bar (overpressure)	480 100
WA 700/2	Retractable armature for measurements in pipework, up to 2 bar (overpressure)	480 102
Welding socket		Order No.
ESS-WA 700/ST	Steel welding socket (St 33)	480 104
ESS-WA 700/VA	Stainless steel welding socket (1.4571)	480 106

Please refer to table on page 130/131

Cleaning System

Some applications, in particular in the wastewater treatment, require special precautions for permanent and interference-free operation.

Cleaning System

- Solutions for all plants
- Controllable via any WTW monitor
- Compressed air cleaning – winterized and interference-free



Efficient compressed air cleaning put into practice:

For a continuous compressed-air cleaning system there are two options:

Option 1:

Compressed-air supply is provided at the plant. You require the following components

- Cleaning head CH
- Valve module (MIQ/CHV PLUS or DIQ/CHV with MIQ/PS)

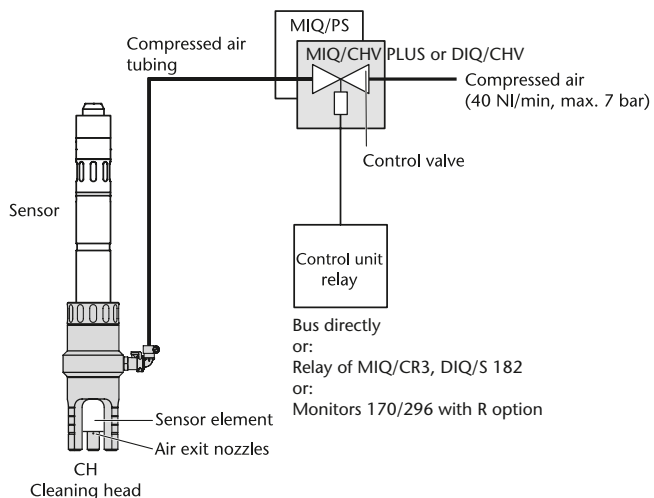

Option 2:

Compressed-air supply is not provided at the plant. You require the following components

- Cleaning head CH
- Cleaning Air Box
- Monitor with relay output

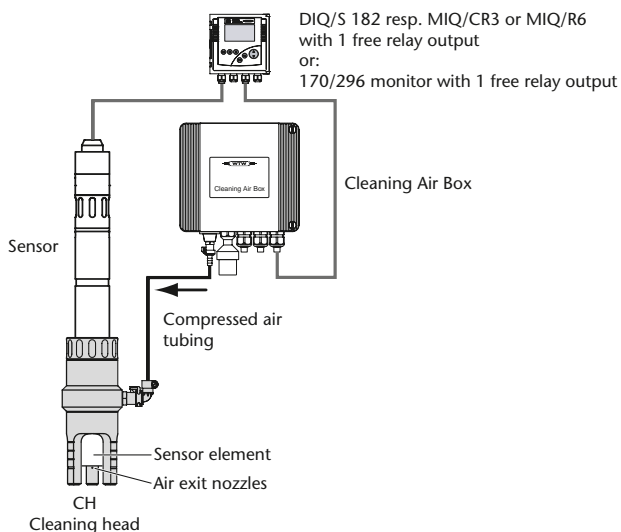

For cleaning, compressed air is blown at the sensor element (from external source) freeing it from pollutants. The compressed air from the cleaning air box or installation to the sensor is switched on or off electronically by an activated control valve or relay. The control is regulated by a timer via the IQ SENSOR NET or via a relay of the measuring system.

Cleaning Air Box

- Oil-free compressed-air
- Most easy installation
- Decentralized weatherproof compressed-air supply on site

The cleaning air box is a air-pressure compressor supplying the cleaning air to the various sensors.

Compared with the former systems with the cleaning head valve (CHV) the cleaning air box does not require any special valve installation as well as no compressed-air supply on site.

The cleaning air box can be controlled by any WTW supplied converter via a relay (exception: MIQ/VIS).

The great advantage of this cleaning air box compared to any former systems with CHV (cleaning had valve):

No compressed-air system is required on site. The cleaning air box is delivered in two models 115 VAC (480 017) and 230 VAC (480 019).

Thanks to the installation of the membrane compressor and the pre-switched filters, the cleaning air box provided oil and dust-free compressed-air, which guarantees keeping the sensor clean.

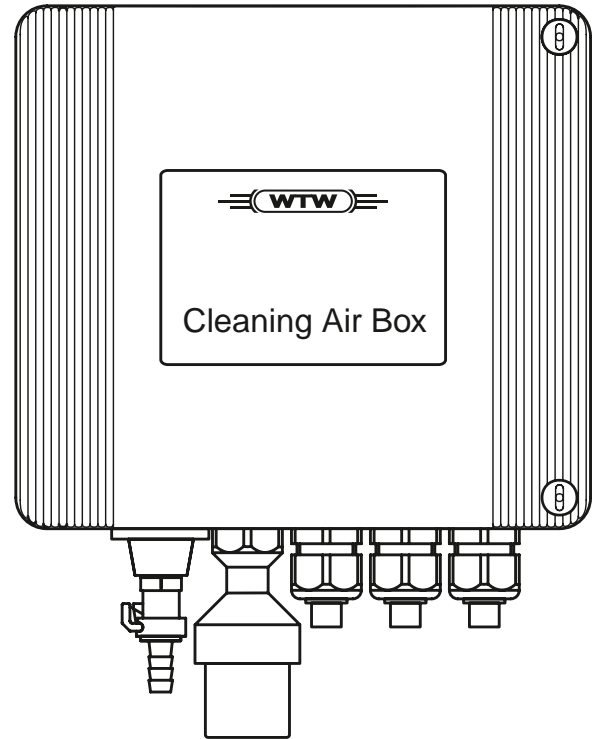

Ordering Information		Order No.
CH	Cleaning head with tube (16.4 yds/ 15 m)	900 107
MIQ/CHV PLUS	Valve module for cleaning system (IQ SENSOR NET, system 184 XT or 2020 XT)	480 018
DIQ/CHV	Valve module for cleaning system (IQ SENSOR NET, system 182)	472 007
MIQ/PS	Wide-range power supply	480 004
		Order No.
Cleaning Air Box	Cleaning air box with compressor, 230 VAC with air-filter	480 019
Cleaning Air Box	Cleaning air box with compressor, 115 VAC with air-filter	480 017
AF/Cleaning Air Box	Air-filter for the suction side of the pump, annual exchange	408 026
RM/Cleaning Air Box	Spare membrane for the membrane pump of the cleaning box, exchange after 5000 operating hours or after 5 years	480 027
BPV	Check-valve, which is installed in the box between pump and compressed-air hose. It stops the measuring solution from rising and entering the cleaning nozzles in the hose system and contaminating it. It can also be used for the EBST 700 DU/ND.	480 029

The individual configurable multi-parameter system

MULTILINE 1000

- Intuitive menu navigation
- Pre-mounted panels
- Excellent cost / performance ratio
- No chemicals

As the only complete system, **MULTILINE 1000** offers convenient measuring and output of up to six parameters with a single transmitter.

Ready-to-operate monitoring system offers easy interface, including the touchscreen with intuitive menu navigation.

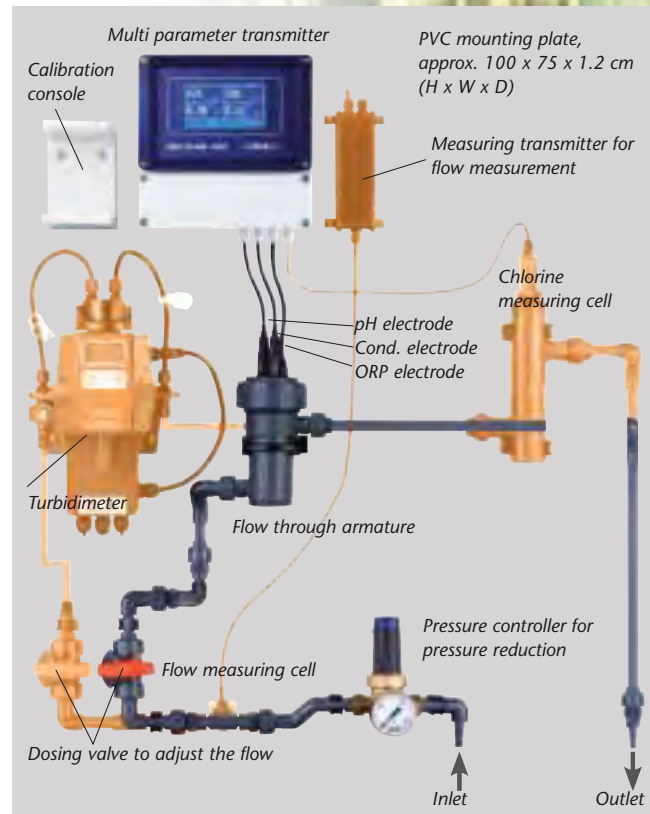

Also single parameters

The parameters pH, ORP, C_{ond} , D.O. and chlorine are mounted on a panel and are supplied with a pressure reducer as well as a ball valve for flow-through-regulation. The flow-control switch can be integrated optionally, to give an alarm signal when flow is disrupted.

Parameters

pH/ORP pH 5000

Conductivity LF 6000

Chlorine (free and total) – electrochemical CI 7010

Chlorine (free and total) – photometric Chlorine 3000

Turbidity Turb 2000 – Turb 2120

Oxygen Oxi 4000



Example: Chlorine measurement CI 7010

Instruments for measuring turbidity for any application



Turb 2000 – Turb 2120

- Easy calibration
- Integrated bubble trap
- Proven system

The nephelometric turbidity measuring is offered with or without ultrasonic cleaning of the flow-through cuvette.

Selection between measuring acc. DIN 7027 with infrared light and measuring acc. US EPA 180.1 with white light.

The instruments not only offer excellent handling, but also technical specifications:

- Measurement range 0 ... 1000 NTU, accuracy 0.0001 NTU
- RS 485 MODBUS or 4 – 20 mA output adjustable
- Two programmable alarm outputs 250 VAC/2A

Analyzers for free and total chlorine



Chlorine 3000

- Low consumption of reagents
- 30 days maintenance-free operation
- Excellent cost/performance ratio

The analyzer operates photometric with the DPD method acc. US EPA.

The measuring range from 0 – 10 mg/l is extremely wide with an accuracy of 0.01 mg/l. The instrument features 2 alarm outputs, one 4 – 20 mA output as well as one RS 485 MODBUS output.

WTW – Laboratory and Field Instrumentation

Are you interested?

Please order the new
WTW Catalog "Laboratory
and Field Instrumentation"



Field Meters

ProfiLine 1970i

- pH
- D.O.
- Cond
- Multi



Laboratory Meters inoLab®

Multi-parameter:
Multi 9310 IDS,
Multi 9420 IDS,
Multi 9430 IDS
Single Parameter:
7110, 7310, 7320

- pH
- Cond
- ISE
- Multi
- D.O.



Photometers

photoLab® 6100 VIS / 6600 UV-VIS
photoLab® S6 / S12
pHotoFlex® Series

- Photometrical Tests
- wide range of tests available*



Portable Meters

Multi-parameter:
MultiLine® 3000 Series/
Multi 340i / 350i /
3400i* / 3500i*
Single Parameter:
ProfiLine 3000 Series

- pH
 - Cond
 - ISE
 - Multi
 - D.O.
 - Cond
- * North American version*



Turbidity Meters

Turb® 430 / 355 / 550 / 555

- NTU



Multi-parameter probe

MPP 910 / 930 IDS

- pH
- D.O.
- Cond
- Multi
- Depth profiles



Respirometer OxiTop®

OxiTop® / OxiTop® Control

- BOD
- Respiration

*soil respiration,
biodegradation
OECD, Biogas
determination,
respiration rate*





Environmental Monitoring

e.g.
Photometric Measurements
with pHotoFlex®



Swimming Pools

e.g.
pH Control Measurement
with ProfiLine pH 3110



Pharmaceutical Water

e.g.
Conductivity Flow
Measurement
with
inoLab® Cond 7310



Food and Beverage Industry

e.g.
Turbidity Measurement
with Turb® 430 + LabStation



Chemical Water

e.g.
pH/Conductivity
Measurement
with
inoLab® Multi 9420 IDS



Food and Beverage Industry

e.g.
pH/D.O. Measurement
with MultiLine® 3420
+ FDO® 925



Ground Water

e.g.
D.O./pH/Conductivity
Measurement
with Multi 350i/3500i*
and MPP 350



Cosmetics/Detergents

e.g.
pH Measurement
with inoLab®
Multi 9430 IDS



Surface Water

e.g.
D.O./pH/Conductivity
Measurement with
MultiLine® 3430
+ FDO® 925



Semi-Conductor Industry

e.g.
pH/Conductivity Measurement
with ProfiLine Cond 3210
+ KLE 325



Depths Profiles, Limnology

e.g.
D.O./pH/ Conductivity
Profiles with MultiLine® 3430
+ MPP 930 IDS



Process Technology

e.g.
D.O./pH/Conductivity
Measurement
with MultiLine® 3430
+ FDO® 925



Biotechnology (not autoclavable)

e.g.
D.O./pH/Conductivity
Measurement
with MultiLine® 3410 + FDO® 925

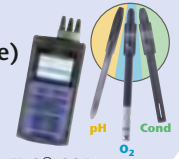

Wastewater Treatment Plant: Aeration Basin

e.g.
D.O. Control Measurement
with MultiLine® 3420
+ FDO® 925



BOD Measurement

e.g. Dilution BOD with Analysis Program: inoLab® BSB/BOD 740; easy Self-Check Measurement with OxiTop®



Biodegradation according to OECD

OECD 301: Determination
with OxiTop® Control



Fish Farming

e.g.
D.O. Measurement
with ProfiLine Oxi 3205
and DurOx®
incl. Protection Cap



Wastewater: COD

e.g. COD Determination
in wastewater
with photoLab® S12



Company highlights	
1945	Company founded by Dr. Karl E. Slevogt
1948	Renamed to <i>Wissenschaftlich-Technische-Werkstätten (WTW)</i>
1954	Introduction of first WTW pH meter
1965	Introduction of first WTW dissolved oxygen meter
1976	Bavarian State Award for the Combibox compact multi-parameter system
1982	Introduction of the world's first zero-current-free (stable zero point) dissolved oxygen sensor for field measurements
1983	Start of WTW's online measuring technology program
1986	First company to offer a 3-electrode dissolved oxygen sensor (TriOxmatic®) with automatic calibration on air (OxiCal®)
1987	First company to offer a 4-electrode conductivity sensor (TetraCon®) for portable water analysis
1993	First manufacturer of D.O., pH and conductivity measuring systems to be certified to ISO 9001
1995	<ul style="list-style-type: none"> • Introduction of the mercury-free OxiTop® system for manometric BOD determination • First company to offer monitors with built-in lightning protection
1997	New photoLab® laboratory photometers combine precision with outstanding ease of use
1998	<ul style="list-style-type: none"> • Introduction of the PurCon® sample preparation system as a replacement for conventional filtration systems • First WTW spectrophotometer
1999	The new laboratory instruments of the inoLab® family set new standards for the measurement of pH, D.O., conductivity, ISE and temperature
2000	Introduction of TresCon® – the modular analytical system for the continuous measurement of ammonium, nitrite, nitrate, phosphate
2001	<ul style="list-style-type: none"> • IQ SENSOR NET – the multi-parameter measuring system offers unlimited possibilities for online measurements • The new VisoTurb® and ViSolid® turbidity and solid sensors with their revolutionary ultrasonic keeping clean system give "low-maintenance" a completely new meaning
2002	<ul style="list-style-type: none"> • AmmoLyt® 700 IQ enables reliable Online direct measurement of Ammonium • PurCon® IS: Sample Preparation – directly without pump

About us

Since 2011, WTW is a company of the Xylem Group, which operates worldwide in its core business of water. Xylem has set a goal to contribute to the improvement of water management with innovative solutions and technologies in the world. This global corporate goal offers us at WTW an excellent base to use our expertise and experiences as entrepreneurs and socially in solving the global water problem: Through ongoing developments and improvements of our proven sensor and analysis technology, we want to make an important contribution to safeguarding water quality for future generations - a claim that inspires us and fills us with joy and pride.



Ulrich Schwab, WTW managing director since May 2012

If you want to learn more about Xylem:
www.xyleminc.com



a xylem brand

Online Instrumentation

For many years, the IQ SENSOR NET has set the standard for online measuring technology. It is suitable for conventional instrumentation with analog outputs as well as for field bus instrumentation. The innovative digital sensors in this system represent the state of the art in process measuring.

A new controller family MIQ/MC2 with integrated USB and LAN interfaces opens the IQ SENSOR NET System to the future-proof world of internet communication via TCP/IP technology. The new spectral UV-VIS sensors CarboVis®, NitraVis® and NiCaVis® allow for chemical-free measurements of COD, TOC, BOD, SAC, NO₃ and TSS directly in the wastewater process. Their new optical design, integrated ultrasonic cleaning system and high-tech materials Titanium and PEEK assure high measurement reliability, simple handling and extreme durability.

The new interface level sensor IFL 700 IQ is ideal for sludge management at wastewater treatment plants: based upon the ultrasonic measuring principle it detects sludge-water interface levels via runtime of ultrasound signal echoes. The IQ SENSOR NET system is therefore the most flexible, digitally based system providing from 1 to 20 measuring points.

For the measuring and control of wastewater, WTW offers the world's most complete line of pH/ORP, D.O., Conductivity, Nitrogen, Carbon, Phosphate and unique self-cleaning Turbidity instrumentation as well as comprehensive accessories.

The dependability, reliability, and versatility of WTW field proven Ammonia, Phosphate, Nitrite and Nitrate Analyzers, probes, and pH, ORP, D.O., and Conductivity systems and meters have established WTW products as industry standards worldwide.

Laboratory & Field Instrumentation

The product range from WTW offers the world's most complete line of pH/ORP, D.O./ BOD/Respirometry and Conductivity Instruments, Turbidity Meters and Photometers including reagents. WTW systems range from rugged waterproof, portable field meters to an integrated line of laboratory instruments and accessories, as well as completely new multi-parameter instruments with state-of-the-art technology for lab and field applications.

The MultiLine® multi-parameter instruments, with high-resolution graphic display, feature extreme durability for measurements in a variety of applications where parameters can be measured sequentially or simultaneously.

The new inoLab® laboratory meter line include digital high-performance multi-parameter instruments with IDS technology taking advantage of the innovative new digital IDS sensors, which convert the measuring values directly in the sensor and transfer the digital signals to the measuring instrument, delivering precision and convenience.

WTW offers premium optical technology instruments with the spectrophotometers of the photoLab® 6000 series for the UV and VIS range.

WTW has built a solid reputation in its more than 60 year history by providing "best-in-class" products with unparalleled customer and technical support. WTW strives to deliver solutions to our customers measuring problems. Our Customer Care Centers are dedicated to ensuring each customer's individual success. WTW's extensive applications library, coupled with knowledgeable applications specialists, provide for rapid resolutions to technical challenges.

With support facilities around the globe, the WTW manufacturing center, located just south of Munich, Germany, delivers quality technical instrumentation with continuous support. We are proud to present our product offering to you and look forward to serving your needs. "Made in Germany".



Company highlights

2003	<i>NitraLyt® 700 IQ is a perfect supplementary nutrient parameter (Nitrate) for Online direct measurement</i>
2004	<ul style="list-style-type: none"> • Multi-parameter portable meter Multi 350i represents state-of-the-art technology in field applications • NitraVis®, CarboVis® and NiCaVis® – spectral "in-situ" Online sensors for Nitrate, Carbon and TSS measurement for wastewater control
2005	<ul style="list-style-type: none"> • Portable photometers and turbidity meters for universal applications: pHotoFlex®/pHotoFlex® Turb 430 IR • IQ SENSOR NET System 182 compact 2 channel transmitter
2006	<ul style="list-style-type: none"> • VARiON® ammonium and nitrate multisensor with automatic compensation of interference ions
2007	<ul style="list-style-type: none"> • The new optical D.O. sensor FDO® 700 IQ completes the WTW portfolio for online D.O. measuring • The new spectrophotometers of the photoLab® 6000 series combine systematic and spectral analysis with well proven quality assurance AQA.
2008	<p>The IQ SENSOR NET system keeps on developing:</p> <ul style="list-style-type: none"> • New terminal/controller T 2020 XT with USB and dual-processor function • System 182 XT-4: perfect for up to 4 sensors • IQ-LabLink joins online measuring with laboratory calibration
2009	<i>The new ProfiLine single parameter portable meters feature extreme robustness and outstanding ease of use</i>
2010	<p>MultiLine® IDS – new digital world of portable measurement:</p> <ul style="list-style-type: none"> • MultiLine® – digital multi-parameter portable meters and • FDO® 925 – optical dissolved oxygen sensor for field and lab
2011	<i>inoLab® Multi IDS</i> – IDS technology for the lab
2012	<ul style="list-style-type: none"> • UV-VIS sensors – Next generation of CarboVis®, NitraVis® and NiCaVis® sensors with new optical design, integrated ultrasonic cleaning technology and high-tech materials • IFL 700 IQ sensor – Interface level measurement for sludge management

www.WTW.com

Information around the Clock

New Products

WTW presents its complete line of new products, innovative measuring and analytical instruments, helpful accessories, useful system extensions, special sets and much more *24 hours a day*.

Applications

WTW can provide you with solutions for all your measurement needs. In addition, you will find tech tips, application notes, *and much more*.

Downloads

Need a Manual, Application Report or a WTW Certificate? *Have a look at our Download Area.*

Contact Addresses

Looking for your local contact?

Here you can find your "local WTW": *contact addresses, representatives, distributors... Click!*



Index

A	Page	DIQ/S 182	94, 97	L	Page	OS 210	55, 109
Accessories	124	DIQ/S 182 XT	94, 97	LF 170 RT RS, 230 VAC	103	Oxi 170 RT RS, 230 VAC	101
ADA-DF1	130	DIQ/S 182 XT-4	94, 97	LF 170 RT, 230 VAC	103	Oxi 170 RT, 230 VAC	101
ADA-DF10	130	DIQ/S 182 XT-4-MOD/24V	94, 97	LF 170, 230 VAC	103	Oxi 170, 230 VAC	101
ADA-DF11	130	DIQ/S 182 XT-4-PR/24V	94, 97	LF 296 RT RS, 230 VAC	103	Oxi 296 RT RS, 230 VAC	101
ADA-DF12	130	DIQ/S 182 XT-4-MOD	94, 97	LF 296 RT, 230 VAC	103	Oxi 296 RT, 230 VAC	101
ADA-DF13	130	DIQ/S 182 XT4-PR	94, 97	LF 296, 230 VAC	103	Oxi 296, 230 VAC	101
ADA-DF14	130	DIQ/S 182 XT-4/24V	94, 97	LRD 01	31, 32		
ADA-DF15	130	DIQ/S 182 XT/24V	94, 97	LRD 325	31, 32		
ADA-DF2	130	DIQ/S 182-MOD	94, 97			P	Page
ADA-DF3	130	DIQ/S 182-MOD/24V	94, 97			PB 13	119, 122
ADA-DF4	130	DIQ/S 182-PR	94, 97	M	Page	PB 150-2	118, 120
ADA-DF5	130	DIQ/S 182-PR/24V	94, 97	MIQ Modules	91, 97	PB 150-2/1	118, 120
ADA-DF6	130	DIQ/S 182/24V	94, 97	MIQ/24V	91, 93, 97	PB 150-2/R12	118, 120
ADA-DF7	130	Dissolved Oxygen sensors	8, 15	MIQ/Blue PS	82, 91, 93	PB 150-SE	118, 121
ADA-DF8	130			MIQ/Blue PS SET	97	PB 150-SE/12	118, 121
ADA-DF9	130	E	Page	MIQ/C6	91, 93, 97	PB 150-SE/24	118, 121
ADA-DF9/SW	131	EBS 700-DU/N	132	MIQ/CHV PLUS	91, 93, 97, 134, 135,	PB 17	119, 122
ADA-WA 1	130, 133	EBST 700-DU/N	132	MIQ/CR3	91, 93, 97	PB 25 S	119, 123
ADA-WA 2	130, 133	EBST 700-DU/ND	132	MIQ/IC2	91, 93, 97	PB 25 S/24	119, 123
ADA-WA 3	130, 133	EcoLine® LF 170	98, 103	MIQ/IB	91, 93, 97	P 700 IQ	64
AF/Cleaning Air Box	135	EcoLine® Oxi 170	98, 101	MIQ/JBR	91, 93	P 700 IQ-PO230	66
AmmoLyt®Plus 700 IQ	48	EcoLine® pH 170	98, 102	MIQ/JBR	91, 93	P 700 IQ-PI230	66
Analog Sensors	14, 17, 24, 32	EH/F 170	128	MIQ/MC2	88, 91, 93	P 700 IQ-O230	66
		EH/P 170	128	MIQ/MC2-PR	91, 93	P 700 IQ-I230	66
B	Page	EH/U 170	125	MIQ/MC2-MOD	91, 93	PB 8-115 V	118, 120, 121
BE/M 170	129	EH/W 170	128	MIQ/PS	91, 93, 97	PB 8-230 V	118, 120, 121
BE/M 170 D	129	EH2/U 170	125	MIQ/R6	91, 93, 97	PCIS-MSG	114
BE/R 170	129	EH3/U 170	125	MIQ/TC 2020 XT	83, 85, 90, 91, 93	PCIS-MSK	114
BE/R 170D	129	ESS 700 VA/10	132	MIQ/TC 2020 XT-H3	91	PCIS-MSS	114
BE/ST 170	128	ESS 700 VA/N	132	MIQ/TC 2020 XT-H3 C6	91	PCIS-PL10/H	114
BE/ST 170M	128	ESS-WA 700/ST	133	Monitors	96, 98	PCIS-PL20/H	114
BE/ST 170R	128	ESS-WA 700/VA	133	Mounting Stands and Fixtures	127	PCIS-PL5/H	114
BPV	135			MR/SD 170	129	PCIS-Set115	114
		F	Page	MS/DIQ	97	Permeat line	114
C	Page	FDO® 700 IQ	8, 10, 14, 15			PF 105	115
CarboVis®	60	FDO® 700 IQ SW	15	N	Page	pH 170 RT RS, 230 VAC	102
CarboVis® 701 IQ	61	FDO® 701 IQ	14, 15	NiCaVis®	53, 54, 61	pH 170 RT, 230 VAC	102
CarboVis® 701 IQ TS	61	FDO® 701 IQ SW	15	NiCaVis® 705 IQ	54, 61	pH 170, 230 VAC	102
CarboVis® 705 IQ	61	Filtration P 700 IQ	67	NiCaVis® 705 IQ NI	54, 61	pH 296 RT RS, 230 VAC	102
CarboVis® 705 IQ TS	61	Fixtures	127	NiCaVis® 701 IQ NI	54, 61	pH 296 RT, 230 VAC	102
CH	47, 49, 52, 135	Flow-thru adapters	130	NiCaVis® 705 IQ NI	54, 61	pH 296, 230 VAC	102
CHEMtrac 830M	25	Flow-thru vessels	131	NitraLyt®Plus 700 IQ	51	PL 80-225pH	26
Cleaning Air Box	135			NitraVis®	53, 54	PL 81-225pHT VP	26
Combination electrodes	21, 24, 26	I	Page	NitraVis® 701 IQ	54	PL 82-225pHT VP	26
Conductivity cells	30, 31, 32	IFL 700 IQ	72	NitraVis® 701 IQ TS	54	PL 89-225Pt	26
Configuration guide analog monitors	99, 100	IFL 701 IQ	72	NitraVis® 705 IQ	54	ProcessLine pH/ORP combination electrodes	26
		IFL-D	73	NitraVis® 705 IQ TS	54	PurCon®	113, 115
		IFL-RM	73			PurCon® IS	114
D	Page	IQ Systems	80	O	Page	PurCon® IS/2-230	114
D 702/N	131	IQ Sensors	81	OA 110	50, 109	PurCon® IS/4-230	114
Digital Sensors	14, 15, 22, 31, 32, 73	J	Page	ON 210	55, 109	PurCon®/115	113
DIQ Modules	97	Junction boxes	125	ON 510	56, 109	PurCon®/230	113
DIQ/CHV	47, 49, 52, 54, 61, 94, 97, 135	K	Page	OP 210/MB 1	68, 109		
DIQ/CHV	47, 49, 52, 54, 61, 94, 97, 135	KI/pH 170	125	OP 210/MB 2	68, 109	Q	Page
DIQ/JB	94, 97	KI/S	125	OP 210/MB 3	68, 109	QuadroLine® LF 296	103
				OP 510	69, 109	QuadroLine® Oxi 296	101
				Orthophosphate measurement	64	QuadroLine® pH 296	102
				Orthophosphate analyzer	64		

Index

R	Page	Sensor extensions	125	TresCon® N 511	56, 109	V	Page
Retractable Armatures	25, 133	Sensor holders	125	TresCon® Nitrate, N 211	55, 109	Vario Mounting Stands	128
RM/Cleaning Air Box	135	Sensor holding devices	128	TresCon® Nitrate/SAC, S 211	55, 109	VARION®Plus 700 IQ	46
S	Page	Sludge level measurement	70	TresCon® Nitrite, N 511	56, 109	VARION®Plus A comp SET	47
S 200	126, 128	Sludge level sensor	70	TresCon® Orthophosphate, P 211/MB 1	68, 109	VARION®Plus AN/A comp SET	47
SACIQ-7,0	15, 23, 32, 38, 39, 81	SNCIQ	77, 97	TresCon® Orthophosphate, P 211/MB 2	68, 109	VARION®Plus AN/N comp SET	47
SD/K 170	129	SNCIQ/UG	97	TresCon® Orthophosphate, P 211/MB 3	68, 109	VARION®Plus CI	52
SD/M 170-D	129	SSH/IQ	127, 129	TresCon® P 211/MB 1	68, 109	VARION®Plus K	49
SensoLyt® 650-7	22, 24	Standard solutions	47	TresCon® P 211/MB 2	68, 109	VARION®Plus N comp SET	47
SensoLyt® 690-7	22, 24	Stationary Samplers	120	TresCon® P 211/MB 3	68, 109	VARION®Plus NH ₄	49
SensoLyt® 700 IQ	22, 23	Sun shields	129	TresCon® P 211/MB 1	68, 109	VARION®Plus NO ₃	52
SensoLyt® 700-7	22, 24	System 182	94	TresCon® P 211/MB 2	68, 109	VARION®Plus Ref	49, 52
SensoLyt® DW	21, 24	System 2020 XT	82	TresCon® P 211/MB 3	68, 109	VARION®Plus SETs	47
SensoLyt® DWA	21, 24	System 2020 XT (USB)	84	TresCon® P 511	69, 109	VARION®Plus/ES-1	47
SensoLyt® DWA	21, 24	System 2020 XT (Connect)	84, 88	TresCon® S 211	55, 109	VARION®Plus/ES-2	47
SensoLyt® combination electrodes	21, 24	T	Page	TresCon® Total Phosphorus, P 511	69, 109	VB 105	115
SensoLyt® EC	21, 24	TC 2020 XT	91	TresCon® Uno	110	VIS FT-1	131
SensoLyt® ECA	21, 24	TCU/A111	50, 111	TriOxmatic® 12, 14, 15, 17, 93, 99		VIS Set/EH	128
SensoLyt® pH/ORP sensor systems	20	TCU/N211	55, 111	TriOxmatic® 690	14, 17, 99	VIS Set-F	128
SensoLyt® Pt	21, 24	TCU/N511	56, 111	TriOxmatic® 700	14, 17, 99	ViSolid® 700 IQ	35, 37, 39
SensoLyt® PtA	21, 24	TCU/P211-MB1	68, 111	TriOxmatic® 700 IN	14, 17, 99	VisoTurb® 700 IQ	35, 37, 38
SensoLyt® SE	21, 24	TCU/P211-MB2	68, 111	TriOxmatic® 701	14, 17, 99		
SensoLyt® SEA	21, 24	TCU/P211-MB3	68, 111	TriOxmatic® 700 IQ	14, 15, 16, 93		
SensoLyt® SEA-HP	21, 24	TCU/S211	55, 111	TriOxmatic® 701 IQ	14, 15, 16, 93		
SensoLyt® sensors assemblies	22, 23, 24	TetraCon® 700 IQ	30, 31, 32	TriOxmatic® 702 IQ	14, 15, 16, 93		
Sensor adapter	133	TetraCon® 700	30, 31, 32, 100				
		TresCon® A 111	50, 109	U	Page	W	Page
		TresCon® Ammonium, A 111	50, 109	UA 130	125	WA 700/10	133
		TresCon® basic instruments	109	UA 55	125	WA 700/2	133
		TresCon® N 211	55, 109	UA-SO	125	Weld-in socket	132, 133

General information

1. Special versions of instruments on request.
2. Accessories and spare parts for older models – please make separate inquiry.
3. In order to avoid our customers having to pay a surcharge for small-volume purchases, we supply our consumables in practical minimum ordering quantities.

Technical alterations

The technical description corresponds to the current products. Alterations because of technical improvements are possible.

Illustrations

We draw your attention to the fact that the illustrations are intended to clarify certain points. There may therefore be discrepancies between the illustrations and the written text.

Liability

We accept no responsibility for printing errors, writing errors or mistakes in the translation.

Publisher



Wissenschaftlich-Technische Werkstätten GmbH

Dr.-Karl-Slevogt-Strasse 1
D-82362 Weilheim

Germany

Tel: +49 881 1 83-0

Fax: +49 881 1 83-420

E-Mail: Info.WTW@Xylem.com

Internet: www.WTW.com

Edition March 2013

WTW Online Instrumentation at the Wastewater Plant

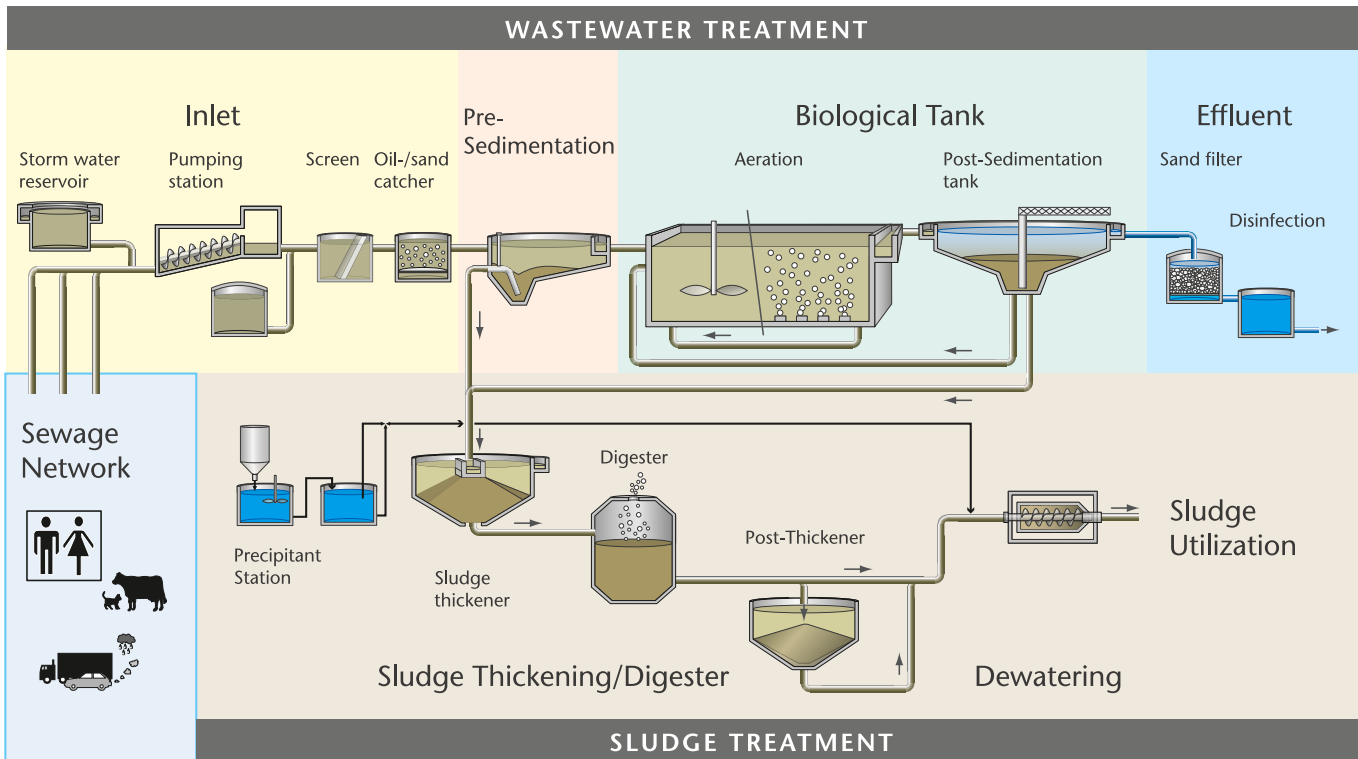

	Application	WTW Online Instrumentation
Inlet	Sewage Network	Sampler
	Inlet	pH, Conductivity, COD, Nitrate, Nitrite, Ammonium
	Fecal Reception	pH, Conductivity, Sampler
	Oil/Sand Catcher	pH, Conductivity, Sampler
	Industrial Wastewater (Neutralization)	pH, Conductivity, Sampler
Pre-sedimentation	Pre-sedimentation	Ammonium, Nitrate, Phosphate, TSS, COD/TOC/DOC/BOD/SAC
Biological Tank	Aeration	D.O., Ammonium, Nitrate, Nitrite, Phosphate, TSS, pH
	Post-sedimentation	TSS, Turbidity, Sludge level
	Cyclic Nitrification/Denitrification	D.O., Ammonium, Nitrate, Nitrite, TSS, pH
	Simultaneous Precipitation Dosage	Phosphate
	Biofilter	D.O., Ammonium, TSS, pH
Effluent	Effluent	Ammonium, Nitrate, Nitrite, N-Total, Phosphate/P-Total, pH, Conductivity, D.O., Turbidity, COD/TOC/DOC/BOD/SAC, Sampler
	Sand Filter	Turbidity, Phosphate
	Post-precipitation	Phosphate
	UV Disinfection	Turbidity
Sludge Thickening	Pre-thickener	Turbidity, TSS
	Centrifuge	Turbidity, TSS
	Flotation	Turbidity
	Flocculation Dosage	Turbidity
Digester	Sludge Digestion	pH, TSS
	Post-thickener	TSS
Dewatering	Chamber Filter Press	Turbidity, TSS
	Decanter	Turbidity, TSS
	Band Filter Press	Turbidity

What can Xylem do for you?

We're 12,500 people unified in a common purpose: creating innovative solutions to meet our world's water needs. Developing new technologies that will improve the way water is used, conserved, and re-used in the future is central to our work. We move, treat, analyze, and return water to the environment, and we help people use water efficiently, in their homes, buildings, factories and farms. In more than 150 countries, we have strong, long-standing relationships with customers who know us for our powerful combination of leading product brands and applications expertise, backed by a legacy of innovation.

For more information on how Xylem can help you, go to www.xylem.com



Wissenschaftlich-Technische Werkstätten GmbH

Dr.-Karl-Slevogt-Strasse 1
D-82362 Weilheim
Germany

Phone: +49 881 183-0
Fax: +49 881 183-420
E-Mail: Info.WTW@Xylem.com
Internet: www.WTW.com

Distributed by

