

O&M

perations aintenance



Best Practices

A Guide to Achieving *Operational Efficiency*

Technology

Energy and Water

Management

Environment

Training

Economics

Administration

Engineering



Operational Efficiency



U.S. Department of Energy

Office of Energy Efficiency and Renewable Energy
Federal Energy Management Program

1-800-363-3732

www.eren.doe.gov/femp

Operations & Maintenance

Best Practices

A Guide to Achieving Operational Efficiency

G. P. Sullivan
R. Pugh
A. P. Melendez
W. D. Hunt

December 2002

Prepared by Pacific Northwest National Laboratory
Under Contract DE-AC06-76RL01831
for the Federal Energy Management Program
U.S. Department of Energy

Disclaimer

This report was sponsored by the United States Department of Energy, Office of Federal Energy Management Programs. Neither the United States Government nor any agency or contractor thereof, nor any of their employees, makes any warranty, express or implied, or assumes any legal liability or responsibility for the accuracy, completeness, or usefulness of any information, apparatus, product, or process disclosed, or represents that its use would not infringe privately owned rights. Reference herein to any specific commercial product, process, or service by trade name, mark, manufacturer, or otherwise, does not necessarily constitute or imply its endorsement, recommendation, or favoring by the United States Government or any agency or contractor thereof. The views and opinions of authors expressed herein do not necessarily state or reflect those of the United States Government or any agency or contractor thereof.

Preface

This Operations and Maintenance (O&M) Best Practices Guide was developed under the direction of the U.S. Department of Energy's Federal Energy Management Program (FEMP). The mission of FEMP is to reduce the cost and environmental impact of the Federal government by advancing energy efficiency and water conservation, promoting the use of distributed and renewable energy, and improving utility management decisions at Federal sites. Each of these activities is directly related to achieving requirements set forth in the *Energy Policy Act of 1992* and the goals that have been established in Executive Order 13123 (June 1999), but also those that are inherent in sound management of Federal financial and personnel resources.

This guide highlights O&M programs targeting energy efficiency that are estimated to save 5% to 20% on energy bills without a significant capital investment. Depending on the Federal site, these savings can represent thousands to hundreds-of-thousands dollars each year, and many can be achieved with minimal cash outlays. In addition to energy/resource savings, a well-run O&M program will:

- Increase the safety of all staff, as properly maintained equipment is safer equipment.
- Ensure the comfort, health and safety of building occupants through properly functioning equipment providing a healthy indoor environment.
- Confirm the design life expectancy of equipment is achieved.
- Facilitate the compliance with Federal legislation such as the *Clean Air Act* and the *Clean Water Act*.

The focus of this guide is to provide the Federal O&M/Energy manager and practitioner with information and actions aimed at achieving these savings and benefits.

The guide consists of nine chapters. The first chapter is an introduction and an overview. Chapter 2 provides the rationale for "Why O&M?" Chapter 3 discusses O&M management issues and their importance. Chapter 4 examines Computerized Maintenance Management Systems (CMMS) and their role in an effective O&M program. Chapter 5 looks at the different types of maintenance programs and definitions. Chapter 6 focuses on maintenance technologies, particularly the most accepted predictive technologies. Chapter 7 explores O&M procedures for the predominant equipment found at most Federal facilities. Chapter 8 describes some of the promising O&M technologies and tools on the horizon to increase O&M efficiency. Chapter 9 provides ten steps to initiating an *operational efficiency* program.

Acknowledgments

This report is the result of numerous people working to achieve a common goal of improving operations and maintenance and energy efficiency across the Federal sector. The authors wish to acknowledge the contribution and valuable assistance provided by the staff of the Federal Energy Management Program (FEMP). Specifically, we would like to thank Ab Ream, FEMP O&M Program Manager, for his leadership and support of this program.

In addition, the authors would like to thank Dave Payson, Kathy Neiderhiser, and Cindi Gregg, all of PNNL, for the conscientious, team-oriented, and high-quality assistance they brought to this project.

Contents

Preface	iii
Acknowledgments	v
Chapter 1 Introduction and Overview	1.1
1.1 About This Guide	1.1
1.2 Target Audience	1.2
1.3 Organization and Maintenance of the Document.....	1.2
Chapter 2 Why O&M	2.1
2.1 Introduction	2.1
2.2 Definitions.....	2.1
2.3 Motivation	2.1
2.4 O&M Potential, Energy Savings, and Beyond	2.3
2.5 References	2.4
Chapter 3 O&M Management.....	3.1
3.1 Introduction	3.1
3.2 Developing the Structure	3.1
3.3 Obtain Management Support	3.2
3.4 Measuring the Quality of Your O&M Program	3.3
3.5 Selling O&M to Management	3.4
3.6 Program Implementation	3.4
3.7 Program Persistence	3.5
3.8 O&M Contracting	3.5
3.9 References	3.6
Chapter 4 Computerized Maintenance Management Systems	4.1
4.1 Introduction	4.1
4.2 CMMS Capabilities	4.1
4.3 CMMS Benefits	4.2
4.4 Reference	4.2
Chapter 5 Types of Maintenance Programs	5.1
5.1 Introduction	5.1
5.2 Reactive Maintenance	5.1
5.3 Preventive Maintenance	5.2
5.4 Predictive Maintenance	5.3

5.5	Reliability Centered Maintenance	5.4
5.6	How to Initiate Reliability Centered Maintenance	5.5
5.7	Reference	5.8
Chapter 6 Predictive Maintenance Technologies.....		6.1
6.1	Introduction	6.1
6.2	Thermography	6.3
6.2.1	Introduction	6.3
6.2.2	Types of Equipment	6.3
6.2.3	System Applications	6.4
6.2.4	Equipment Cost/Payback	6.8
6.2.5	Case Studies	6.9
6.2.6	References/Resources	6.10
6.3	Oil Analysis	6.13
6.3.1	Introduction	6.13
6.3.2	Test Types	6.14
6.3.3	Types of Equipment	6.14
6.3.4	System Applications	6.15
6.3.5	Equipment Cost/Payback	6.15
6.3.6	Case Studies	6.15
6.3.7	References/Resources	6.16
6.4	Ultrasonic Analysis	6.19
6.4.1	Introduction	6.19
6.4.2	Types of Equipment	6.19
6.4.3	System Applications	6.20
6.4.4	Equipment Cost/Payback	6.21
6.4.5	Case Studies	6.21
6.4.6	References/Resources	6.21
6.5	Vibration Analysis	6.23
6.5.1	Introduction	6.23
6.5.2	Types of Equipment	6.24
6.5.3	System Applications	6.25
6.5.4	Equipment Cost/Payback	6.26
6.5.5	Case Studies	6.26
6.5.6	References/Resources	6.26
6.6	Motor Analysis	6.29
6.6.1	Introduction	6.29
6.6.2	Motor Analysis Test	6.29
6.6.3	System Applications	6.30
6.6.4	Equipment Cost/Payback	6.30
6.6.5	References/Resources	6.30
6.7	Performance Trending.....	6.33
6.7.1	Introduction	6.33
6.7.2	How to Establish a Performance Trending Program	6.33
6.7.3	System Applications	6.34
6.7.4	Equipment Cost/Payback	6.34
6.7.5	References/Resources	6.34

Chapter 7 O&M Ideas for Major Equipment Types.....	7.1
7.1 Introduction	7.1
7.2 Boilers.....	7.3
7.2.1 Introduction	7.3
7.2.2 Types of Boilers.....	7.3
7.2.3 Key Components	7.5
7.2.4 Safety Issues	7.8
7.2.5 Cost and Energy Efficiency	7.9
7.2.6 Maintenance of Boilers	7.12
7.2.7 Diagnostic Tools	7.12
7.2.8 Case Studies	7.13
7.2.9 Boilers Checklist	7.14
7.2.10 References	7.16
7.3 Steam Traps.....	7.19
7.3.1 Introduction	7.19
7.3.2 Types of Steam Traps.....	7.19
7.3.3 Safety Issues.....	7.22
7.3.4 Cost and Energy Efficiency	7.22
7.3.5 Maintenance of Steam Traps	7.24
7.3.6 Diagnostic Tools	7.26
7.3.7 Case Studies	7.26
7.3.8 Steam Traps Checklist	7.28
7.3.9 References	7.28
7.4 Chillers.....	7.29
7.4.1 Introduction	7.29
7.4.2 Types of Chillers.....	7.29
7.4.3 Key Components.....	7.31
7.4.4 Safety Issues.....	7.31
7.4.5 Cost and Energy Efficiency	7.32
7.4.6 Maintenance of Chillers	7.33
7.4.7 Diagnostic Tools	7.33
7.4.8 Chillers Checklist	7.34
7.4.9 References	7.35
7.5 Cooling Towers	7.37
7.5.1 Introduction	7.37
7.5.2 Types of Cooling Towers	7.37
7.5.3 Key Components.....	7.38
7.5.4 Safety Issues.....	7.38
7.5.5 Cost and Energy Efficiency	7.39
7.5.6 Maintenance of Cooling Towers	7.39
7.5.7 Common Causes of Cooling Towers Poor Performance	7.40
7.5.8 Diagnostic Tools	7.40
7.5.9 Cooling Towers Checklist	7.41
7.5.10 References	7.42
7.6 Energy Management/Building Automation Systems.....	7.43
7.6.1 Introduction	7.43
7.6.2 System Traps.....	7.43
7.6.3 Key Components	7.43

7.6.4	Safety Issues	7.44
7.6.5	Cost and Efficiency	7.44
7.6.6	Maintenance	7.44
7.6.7	Diagnostic Tools	7.45
7.6.8	Case Studies	7.45
7.6.9	Building Controls Checklist	7.46
7.6.10	References	7.46
7.7	Pumps	7.47
7.7.1	Introduction	7.47
7.7.2	Types of Pumps	7.47
7.7.3	Key Components	7.49
7.7.4	Safety Issues	7.50
7.7.5	Cost and Energy Efficiency	7.51
7.7.6	Maintenance of Pumps	7.51
7.7.7	Diagnostic Tools	7.52
7.7.8	Case Study	7.53
7.7.9	Pumps Checklist	7.54
7.7.10	References	7.54
7.8	Fans	7.57
7.8.1	Introduction	7.57
7.8.2	Types of Fans	7.57
7.8.3	Key Components	7.59
7.8.4	Safety Issues	7.59
7.8.5	Cost and Energy Efficiency	7.59
7.8.6	Maintenance of Fans	7.59
7.8.7	Diagnostic Tools	7.60
7.8.8	Case Studies	7.60
7.8.9	Fans Checklist	7.61
7.8.10	References	7.61
7.9	Motors	7.63
7.9.1	Introduction	7.63
7.9.2	Types of Motors	7.63
7.9.3	Key Components	7.65
7.9.4	Safety Issues	7.66
7.9.5	Cost and Energy Efficiency	7.66
7.9.6	Maintenance of Motors	7.67
7.9.7	Diagnostic Tools	7.68
7.9.8	Electric Motors Checklist	7.69
7.9.9	References	7.69
7.10	Air Compressors	7.71
7.10.1	Introduction	7.71
7.10.2	Types of Air Compressors	7.71
7.10.3	Key Components	7.72
7.10.4	Safety Issues	7.73
7.10.5	Cost and Energy Efficiency	7.74
7.10.6	Maintenance of Air Compressors	7.76
7.10.7	Diagnostic Tools	7.78
7.10.8	Case Study	7.78

7.10.9 Air Compressors Checklist	7.79
7.10.10 References	7.80
7.11 Lighting	7.81
7.11.1 Introduction	7.81
7.11.2 Types of Lamps	7.81
7.11.3 Key Components	7.85
7.11.4 Safety Issues	7.86
7.11.5 Cost and Energy Efficiency	7.86
7.11.6 Maintenance Requirements	7.87
7.11.7 Diagnostic Tools	7.87
7.11.8 Lighting Checklist	7.88
7.11.9 References	7.88
 Chapter 8 O&M Frontiers	 8.1
8.1 ACRx Handtool/Honeywell HVAC Service Assistant	8.1
8.2 Decision Support for O&M	8.1
8.3 Performance and Continuous Commissioning Analysis Tool	8.2
8.4 The Whole-Building Diagnostician	8.2
8.5 Reference	8.2
 Chapter 9 Ten Steps to <i>Operational Efficiency</i>	 9.1
 Appendix A – Glossary of Common Terms	 A.1
Appendix B – FEMP Staff Contact List	B.1
Appendix C – Resources	C.1
Appendix D – Suggestions for Additions or Revisions	D.1

Figures

6.2.1 Typical IR spot thermometer	6.3
6.2.2 Internal house wall	6.4
6.2.3 Hot motor bearing easily seen in IR image	6.4
6.2.4 Air breaker problem	6.5
6.2.5 Overload connection problem	6.5
6.2.6 Warm inboard motor bearing	6.6
6.2.7 Possible gearbox problem indicated by white area defined by arrow	6.6
6.2.8 Seized conveyer belt roller as indicated by elevated temperatures in belt/roller contact area	6.7
6.2.9 Inoperable steam heaters seen by cooler blue areas when compared to the operating heaters warmer red or orange colors	6.7
6.2.10 Refractory breakdown readily seen by white area in IR image	6.7
6.5.1 Vibration severity chart	6.24
6.5.2 FFT - Example of graph breaking down vibration level at different frequencies	6.24
6.5.3 Typical vibration transducers	6.24

7.2.1	Horizontal return fire-tube boiler	7.3
7.2.2	Longitudinal-drum water-tube boiler	7.4
7.2.3	Electric boiler	7.4
7.2.4	Adapted from 1999 National Board of Boiler and Pressure Vessel Inspectors incident report summary	7.8
7.2.5	Effect of fouling on water side	7.9
7.3.1	Inverted bucket steam trap	7.19
7.3.2	Bimetallic steam trap	7.20
7.3.3	Bellows steam trap	7.20
7.3.4	Float and thermostatic steam trap	7.21
7.3.5	Disc steam trap	7.21
7.3.6	Energy loss from leaking steam traps	7.23
7.3.7	Failed gasket on blind flange	7.26
7.4.1	Basic cooling cycle-centrifugal unit using single-stage compressor	7.29
7.4.2	Schematic of typical absorption chiller	7.30
7.5.1	Cooling tower	7.37
7.5.2	Direct or open cooling tower	7.37
7.7.1	Technology tree for pumps	7.47
7.7.2	Rotary lobe pump	7.48
7.7.3	Positive displacement pumps	7.48
7.7.4	Centrifugal pump	7.49
7.7.5	Schematic of pump and relief valve	7.50
7.7.6	Pump system energy use and savings	7.53
7.7.7	Retrofit cost savings	7.54
7.8.1	Propeller direct-drive fan	7.57
7.8.2	Propeller belt-drive fan	7.57
7.8.3	Tube-axial fan	7.58
7.8.4	Vane axial fan	7.58
7.8.5	Centrifugal fan	7.58
7.9.1	DC motor	7.63
7.9.2	AC motor	7.64
7.9.3	Parts of a direct current motor	7.65
7.9.4	Parts of an alternating current motor	7.65
7.10.1	Rotary screw compressor	7.71
7.10.2	Typical single acting two-stage compressor	7.72
7.10.3	Helical-lobe rotors	7.73

Chapter 1 Introduction and Overview

The purpose of this guide is to provide you, the Operation and Maintenance (O&M)/Energy manager and practitioner, with useful information about O&M management, technologies, energy efficiency, and cost-reduction approaches. To make this guide useful and to reflect your needs and concerns, the authors met with O&M and Energy managers via Federal Energy Management Program (FEMP) workshops. In addition, the authors conducted extensive literature searches and contacted numerous vendors and industry experts. The information and case studies that appear in this guide resulted from these activities.

It needs to be stated at the outset that this guide is designed to provide information on effective O&M as it applies to systems and equipment typically found at Federal facilities. This guide is not designed to provide the reader with step-by-step procedures for performing O&M on any specific piece of equipment. Rather, this guide first directs the user to the manufacturer's specifications and recommendations. In no way should the recommendations in this guide be used in place of manufacturer's recommendations. The recommendations in this guide are designed to supplement those of the manufacturer, or, as is all too often the case, provide guidance for systems and equipment for which all technical documentation has been lost.

As a rule, this guide will first defer to the manufacturer's recommendations on equipment operation and maintenance.



Actions and activities recommended in this guide should only be attempted by trained and certified personnel. If such personnel are not available, the actions recommended here should not be initiated.



1.1 About This Guide

This guide is designed to serve as a resource for O&M management and technical staff. It does not try to represent the universe of O&M-related material. Rather, it attempts to:

- - Provide needed background information on why O&M is important and the potential for savings from good O&M.
- - Define the major O&M program types and provide guidance on the structure of a good O&M program.
- - Provide information on state-of-the-art maintenance technologies and procedures for key equipment.
- Identify information sources and contacts to assist you in getting your job done.

1.2 Target Audience

O&M/Energy managers, practitioners, and technical staff represent the prime focus of this document. However, a competent O&M program requires the participation of staff from five well-defined

areas: Operations, Maintenance, Engineering, Training, and Administration. While a given site may not have all five of these areas as separate entities, these functions are provided for-it is these staff that are targeted.

A successful O&M program requires cooperation, dedication, and participation at all levels and cannot succeed without everyone involved understanding the basic principles and supporting the cause.

1.3 Organization and Maintenance of the Document

This guide is intended to be a “living document,” that is, one that is amended as things change. It is the intention of the authors to update this guide periodically as new procedures and technologies are developed and employed. Eventually, a Web-based version is anticipated.

The guide consists of nine chapters. This chapter provides an introduction and an overview. Chapter 2 provides the rationale for “Why O&M?” Chapter 3 discusses O&M management issues and their importance. Chapter 4 examines Computerized Maintenance Management Systems (CMMS) and their role in an effective O&M program. Chapter 5 looks at the different types of maintenance programs and definitions. Chapter 6 focuses on maintenance technologies, particularly the most accepted predictive technologies. Chapter 7 explores O&M procedures for the predominant equipment found at most Federal facilities. Chapter 8 describes some of the promising O&M technologies and tools on the horizon to increase O&M efficiency. Chapter 9 provides ten steps to initiating an *operational efficiency* program.

The O&M environment is in a constant state of evolution and the technologies and vocabularies are ever expanding. Therefore, a glossary of terms is presented in Appendix A. Appendix B provides a list of Federal contacts for training and assistance. Appendix C includes a list of organizations and trade groups that have interest or are related to O&M. And finally, Appendix D is a form that can be used to submit suggestions or revisions to this guide.

Again, we designed this to be a useful and “living” document. Please feel comfortable to make suggestions for changes, additions, or deletions using the form found in Appendix D.

Chapter 2 Why O&M?

2.1 Introduction

Effective O&M is one of the most cost-effective methods for ensuring reliability, safety, and energy efficiency. Inadequate maintenance of energy-using systems is a major cause of energy waste in both the Federal government and the private sector. Energy losses from steam, water and air leaks, uninsulated lines, maladjusted or inoperable controls, and other losses from poor maintenance are often considerable. Good maintenance practices can generate substantial energy savings and should be considered a resource. Moreover, improvements to facility maintenance programs can often be accomplished immediately and at a relatively low cost.

2.2 Definitions

Operations and Maintenance are the decisions and actions regarding the control and upkeep of property and equipment. These are inclusive, but not limited to, the following: 1) actions focused on scheduling, procedures, and work/systems control and optimization; and 2) performance of routine, preventive, predictive, scheduled and unscheduled actions aimed at preventing equipment failure or decline with the goal of increasing efficiency, reliability, and safety.

Operational Efficiency represents the life-cycle cost-effective mix of preventive, predictive, and reliability-centered maintenance technologies, coupled with equipment calibration, tracking, and computerized maintenance management capabilities all targeting reliability, safety, occupant comfort, and system efficiency.

2.3 Motivation

On June 3, 2000, President Clinton signed Executive Order 13123 promoting Government-wide energy efficiency and renewable energy, thereby revoking Executive Orders 12902 and 12759, both of which dealt with reducing the Government's energy use. The new Executive Order strengthens the Government's efforts to pursue energy and cost savings, and raises the energy savings goal to a 35% reduction in energy consumption per square foot in non-exempt Federal buildings by the year 2010 compared to a 1985 baseline.

There are multiple goals defined by the Order. The more important goals from the Federal buildings perspective are to:

- Reduce energy use intensity (MMBtu/ft²/year) 30% from the fiscal year (FY) 1985 baseline by FY 2005.
- Reduce energy use intensity 35% from the FY 1985 baseline by FY 2010.
- Increase the use of cost-effective renewable energy and reduce reliance on petroleum-based fuels, and identify and implement all cost-effective water conservation retrofits and operational improvements.

Clearly, these are aggressive targets and many Federal facilities have been working hard to achieve them. In many cases, the approach to achieving these goals has focused on capital intensive upgrades of existing equipment and making use of a variety of financing options including Energy Savings Performance Contracts (ESPCs), local utility financing programs, and other third-party financing options.

While effective, some feel that capital upgrades are not always the most cost-effective solution. Indeed, the authors of this guide contend that low-cost/no-cost O&M measures (including activities referred to as retrocommissioning or retuning) should be the **first** energy savings measure considered. O&M measures should be considered prior to the installation of energy conservation measures for the following reasons:

- Typically, O&M measures are low-cost or no-cost in nature.
- Many O&M measures are easily installed by in-house personnel.
- O&M measures can have immediate payback.
- These measures rarely require the design time, bid preparation, evaluation, and response compared to capital projects that can take up to a year to implement.

Is an Energy Savings Performance Contract Being Considered? (Haas and Sharp 1999)

Some level of retrocommissioning (i.e., O&M best practices) is usually appropriate if you are considering any type of energy savings agreement such as an energy savings performance contract. There are two primary reasons for performing retrocommissioning before obtaining an energy-savings agreement. First, the low-cost energy savings gained from retrocommissioning remains with the building (the owner gets all of the savings) and does not become part of the financial agreement; second, retrocommissioning optimizes the existing equipment so the most appropriate capital measures are selected and financed through the agreement.

A good reason for doing retrocommissioning as part of an energy-savings agreement is to ensure that the performance of new equipment is not hindered because it interfaces with older equipment, components, or systems that are malfunctioning. Even when commissioning is specified for the new equipment, it often stops short of looking at the systems with which the new equipment interfaces or examining how it integrates with other systems or equipment that may affect its performance. This is especially true for energy management control systems. Because controls are an area where many difficulties and misunderstandings occur between building owners and performance contractors, it is a good idea to specify commissioning for both the new and existing equipment that may affect the performance of the new equipment.

When retrocommissioning is performed before the energy-savings agreement or energy savings performance contract is finalized, it is important to inform the contractor about the retrocommissioning activities and give him or her a copy of the final report. If the contractor is not informed and energy bills from prior years are used to help determine the energy baseline, the baseline may be inaccurate. This may cause the cost savings upon which the financing is based to be significantly less than expected, leading to disagreements and even legal battles.

Retrocommissioning performed up front to capture the low-cost savings may not be a wise choice if the savings from the retrocommissioning do not remain with the building but, instead, go into a general fund. In this case, the “low-cost/no-cost” improvements should be part of the performance contract. In this way, a portion of the savings stays with the building as part of the financial arrangement. Integrating the retrocommissioning measures into the energy-savings agreement is a way to capture the savings as part of the investment repayment. The amount invested can be increased when the savings estimates are higher. Moreover, the savings gained from bundling these measures with the capital upgrades – especially if some of the upgrades are marginally cost-effective (i.e., good value but with long paybacks) – help to increase the overall viability and attractiveness of the energy savings performance contract funding.

2.4 O&M Potential, Energy Savings, and Beyond

It has been estimated that O&M programs targeting energy efficiency can save 5% to 20% on energy bills without a significant capital investment (PECI 1999). From small to large sites, these savings can represent thousands to hundreds-of-thousands of dollars each year, and many can be achieved with minimal cash outlays.

Beyond the potential for significant cost and energy/resource savings, an O&M program operating at its peak *operational efficiency* has other important implications:

A demonstration focused on O&M-based energy efficiency was conducted at the U.S. Department of Energy Forrestal Building in Washington, D.C. (Claridge and Haberl 1994). A significant component to this demonstration was metering and the tracking of steam use in the building. Within several months, \$250,000 per year in steam leaks were found and corrected. These included leaks in a steam converter and steam traps. Because the building was not metered for steam and there was not a proactive O&M program, these leaks were not detected earlier, nor would they have been detected without the demonstration. The key lessons learned from this case study were:

- O&M opportunities in large buildings do not have to involve complex engineering analysis.
 - Many O&M opportunities exist because building operators may not have proper information to assess day-to-day actions.
 - Involvement and commitment by building administrators is a key ingredient for a successful O&M program.
- A well-functioning O&M program is a safe O&M program. Equipment is maintained properly mitigating any potential hazard arising from deferred maintenance.
 - In most Federal buildings, the O&M staff are responsible for not only the comfort, but also the health and safety of the occupants. Of increasing productivity (and legal) concern are indoor air quality (IAQ) issues within these buildings. Proper O&M reduces the risks associated with the development of dangerous and costly IAQ situations.
 - Properly performed O&M ensures that the design life expectancy of equipment will be achieved, and in some cases exceeded. Conversely, the costs associated with early equipment failure are usually not budgeted for and often come at the expense of other planned O&M activities.
 - An effective O&M program more easily complies with Federal legislation such as the *Clean Air Act* and the *Clean Water Act*.
 - A well functioning O&M program is not always answering complaints, rather, it is proactive in its response and corrects situations before they become problems. This model minimizes callbacks and keeps occupants satisfied while allowing more time for scheduled maintenance.

When Marion County, Florida, officials realized their new county courthouse was making hundreds of employees sick, they did more than send the workers to the doctor, they sued the builder/operator of the building for bad air and won a \$14.2million judgment (Ewell 1996).

2.5 References

Claridge J. and D. Haberl. 1994. *Can You Achieve 150% of Predicted Retrofit Savings? Is it Time for Recommissioning?* American Council for an Energy Efficiency Economy (ACEEE), Summer Study on Energy Efficiency in Buildings, Volume 5, Commissioning, Operation and Maintenance. ACEEE, Washington, D.C.

Clean Air Act. 1986. Public Law 88-206, as amended, 42 USC 7401 et seq.

Clean Water Act. 1997. Public Law 95-217, as amended, 91 Stat. 1566 and Public Law 96-148, as amended.

Ewell, C. 1996. *Victims of 'Sick Buildings' Suing Builders, Employers.* Knight-Ridder News Service.

Haasl T. and T. Sharp. 1999. *A Practical Guide for Commissioning Existing Buildings.* ORNL/TM-1999/34, Oak Ridge, Tennessee.

PECI. 1999. *Operations and Maintenance Assessments.* Portland Energy Conservation, Inc. Published by U.S. Environmental Protection Agency and U.S. Department of Energy, Washington, D.C.

Chapter 3 O&M Management

3.1 Introduction

O&M management is a critical component of the overall program. The management function should bind the distinct parts of the program into a cohesive entity. From our experience, the overall program should contain five very distinct functions making up the organization: **O**perations, **M**aintenance, **E**ngineering, **T**raining, and **A**dministration—OMETA.

Beyond establishing and facilitating the OMETA links, O&M managers have the responsibility of interfacing with other department managers and making their case for ever-shrinking budgets. Their roles also include project implementation functions as well as the need to maintain persistence of the program and its goals.



3.2 Developing the Structure

Five well-defined elements of an effective O&M program include those presented above in the OMETA concept (Meador 1995). While these elements, Operations, Maintenance, Engineering, Training, and Administration, form the basis for a solid O&M organization, the key lies in the well-defined functions each brings and the linkages between organizations. A subset of the roles and responsibilities for each of the elements is presented below; further information is found in Meador (1995).

Operations

- **Administration** – To ensure effective implementation and control of operation activities.
- **Conduct of Operations** – To ensure efficient, safe, and reliable process operations.
- **Equipment Status Control** – To be cognizant of status of all equipment.
- **Operator Knowledge and Performance** – To ensure that operator knowledge and performance will support safe and reliable plant operation.

Maintenance

- **Administration** – To ensure effective implementation and control of maintenance activities.
- **Work Control System** – To control the performance of maintenance in an efficient and safe manner such that economical, safe, and reliable plant operation is optimized.
- **Conduct of Maintenance** – To conduct maintenance in a safe and efficient manner.
- **Preventive Maintenance** – To contribute to optimum performance and reliability of plant systems and equipment.
- **Maintenance Procedures and Documentation** – To provide directions, when appropriate, for the performance of work and to ensure that maintenance is performed safely and efficiently.

Engineering Support

- **Engineering Support Organization and Administration** – To ensure effective implementation and control of technical support.
- **Equipment Modifications** – To ensure proper design, review, control, implementation, and documentation of equipment design changes in a timely manner.
- **Equipment Performance Monitoring** – To perform monitoring activities that optimize equipment reliability and efficiency.
- **Engineering Support Procedures and Documentation** – To ensure that engineer support procedures and documents provide appropriate direction and that they support the efficiency and safe operations of the equipment.

Training

- **Administration** – To ensure effective implementation and control of training activities.
- **General Employee Training** – To ensure that plant personnel have a basic understanding of their responsibilities and safe work practices and have the knowledge and practical abilities necessary to operate the plant safely and reliably.
- **Training Facilities and Equipment** – To ensure the training facilities, equipment, and materials effectively support training activities.
- **Operator Training** – To develop and improve the knowledge and skills necessary to perform assigned job functions.
- **Maintenance Training** – To develop and improve the knowledge and skills necessary to perform assigned job functions.

Administration

- **Organization and Administration** – To establish and ensure effective implementation of policies and the planning and control of equipment activities.
- **Management Objectives** – To formulate and utilize formal management objectives to improve equipment performance.
- **Management Assessment** – To monitor and assess station activities to improve all aspects of equipment performance.
- **Personnel Planning and Qualification** – To ensure that positions are filled with highly qualified individuals.
- **Industrial Safety** – To achieve a high degree of personnel and public safety.

3.3 Obtain Management Support

Federal O&M managers need to obtain full support from their management structure in order to carry out an effective maintenance program. A good way to start is by establishing a written maintenance plan and obtaining upper management approval. Such a management-supported program is very important because it allows necessary activities to be scheduled with the same priority as other

management actions. Approaching O&M by equating it with increased productivity, energy efficiency, safety, and customer satisfaction is one way to gain management attention and support.

When designing management reports, the critical metrics used by each system should be compared with a base period. For example, compare monthly energy use against the same month for the prior year, or against the same month in a particular base year (for example, 1985). If efficiency standards for a particular system are available, compare your system's performance against that standard as well. The point of such comparisons in management reports is not to assign blame for poor maintenance and inefficient systems, but rather to motivate efficiency improvement through improved maintenance.

3.4 Measuring the Quality of Your O&M Program

Traditional thinking in the O&M field focused on a single metric, reliability, for program evaluation. Every O&M manager wants a reliable facility; however, this metric alone is not enough to evaluate or build a successful O&M program.

Beyond reliability, O&M managers need to be responsible for controlling costs, evaluating and implementing new technologies, tracking and reporting on health and safety issues, and expanding their program. To support these activities, the O&M manager must be aware of the various indicators that can be used to measure the quality or effectiveness of the O&M program. Not only are these metrics useful in assessing effectiveness, but also useful in cost justification of equipment purchases, program modifications, and staff hiring.

Below are a number of metrics that can be used to evaluate an O&M program. Not all of these metrics can be used in all situations; however, a program should use as many metrics as possible to better define deficiencies and, most importantly, publicize successes.

- **Capacity factor** – Relates actual plant or equipment operation to the full-capacity operation of the plant or equipment. This is a measure of actual operation compared to full-utilization operation.
- **Work orders generated/closed out** – Tracking of work orders generated and completed (closed out) over time allows the manager to better understand workloads and better schedule staff.
- **Backlog of corrective maintenance** – An indicator of workload issues and effectiveness of preventive/predictive maintenance programs.
- **Safety record** – Commonly tracked either by number of loss-of-time incidents or total number of reportable incidents. Useful in getting an overall safety picture.
- **Energy use** – A key indicator of equipment performance, level of efficiency achieved, and possible degradation.
- **Inventory control** – An accurate accounting of spare parts can be an important element in controlling costs. A monthly reconciliation of inventory “on the books” and “on the shelves” can provide a good measure of your cost control practices.
- **Overtime worked** – Weekly or monthly hours of overtime worked has workload, scheduling, and economic implications.
- **Environmental record** – Tracking of discharge levels (air and water) and non-compliance situations.

- **Absentee rate** – A high or varying absentee rate can be a signal of low worker morale and should be tracked. In addition, a high absentee rate can have a significant economic impact.
- **Staff turnover** – High turnover rates are also a sign of low worker morale. Significant costs are incurred in the hiring and training of new staff. Other costs include those associated with errors made by newly hired personnel that normally would not have been made by experienced staff.

3.5 Selling O&M to Management

To successfully interest management in O&M activities, O&M managers need to be fluent in the language spoken by management. Projects and proposals brought forth to management need to stand on their own merits and be competitive with other funding requests. While evaluation criteria may differ, generally some level of economic criteria will be used. O&M managers need to have a working knowledge of economic metrics such as:

- **Simple payback** – The ratio of total installed cost to first-year savings.
- **Return on investment** – The ratio of the income or savings generated to the overall investment.
- **Net present value** – Represents the present worth of future cash flows minus the initial cost of the project.
- **Life-cycle cost** – The present worth of all costs associated with a project.

FEMP offers life-cycle cost training along with its Building Life-Cycle Cost (BLCC) computer program at various locations during the year – see Appendix B for the FEMP training contacts.

Life-Cycle Cost Training

The Basic LCC Workshop takes participants through the steps of an LCC analysis, explains the underlying theory, and integrates it with the FEMP criteria. The second classroom course, the Project-Oriented LCC Workshop, builds on the basic workshop and focuses on the application of the methodology to more complex issues in LCC analysis.

For more information: <http://www.eren.doe.gov/Åfemp/resources/training/Å>

3.6 Program Implementation

Developing or enhancing an O&M program requires patience and persistence. Guidelines for initiating a new O&M project will vary with agency and management situation; however, some steps to consider are presented below:

- **Start small** – Choose a project that is manageable and can be completed in a short period of time, 6 months to 1 year.
- **Select troubled equipment** – Choose a project that has visibility because of a problematic history.
- **Minimize risk** – Choose a project that will provide immediate and positive results. This project needs to be successful, and therefore, the risk of failure should be minimal.
- **Keep accurate records** – This project needs to stand on its own merits. Accurate, if not conservative, records are critical to compare before and after results.

- **Tout the success** – When you are successful, this needs to be shared with those involved and with management. Consider developing a “wall of accomplishment” and locate it in a place where management will take notice.
- **Build off this success** – Generate the success, acknowledge those involved, publicize it, and then request more money/time/resources for the next project.

3.7 Program Persistence

A healthy O&M program is growing, not always in staff but in responsibility, capability, and accomplishment. O&M management must be vigilant in highlighting the capabilities and accomplishments of their O&M staff.

Finally, to be sustainable, an O&M program must be visible beyond the O&M management. Persistence in facilitating the OMETA linkages and relationships enables heightened visibility of the O&M program within other organizations.

3.8 O&M Contracting

Approximately 40% of all non-residential buildings contract maintenance service for heating, ventilation, and air conditioning (HVAC) equipment (PECI 1997). Discussions with Federal building managers and organizations indicate this value is significantly higher in the Federal sector, and the trend is toward increased reliance on contracted services.

In the O&M service industry, there is a wide variety of service contract types ranging from full-coverage contracts to individual equipment contracts to simple inspection contracts. In a relatively new type of O&M contract, called End-Use or End-Result contracting, the O&M contractor not only takes over all operation of the equipment, but also all operational risk. In this case, the contractor agrees to provide a certain level of comfort (space temperature, for instance) and then is compensated based on how well this is achieved.

From discussions with Federal sector O&M personnel, the predominant contract type is the full-coverage contract (also referred to as the whole-building contract). Typical full-coverage contract terms vary between 1 and 5 years and usually include options for out-years.

Upon review of several sample O&M contracts used in the Federal sector, it is clear that some degree of standardization has taken place. For better or worse, some of these contracts contain a high degree of “boiler plate.” While this can make the contract very easy to understand/work with and somewhat uniform across Government agencies, the lack of site specificity can make the contract ambiguous and open to contractor interpretation—many times to the Government’s disadvantage.

When considering the use of an O&M contract, it is important that a plan be developed to select, contract with, and manage this contract. In its guide, titled Operation and Maintenance Service Contracts (PECI 1997), Portland Energy Conservation, Inc. did a particularly good job in presenting steps and actions to think about when considering an O&M contract. A summary of these steps are provided below:

- **Develop objectives for an O&M service contract, such as:**
 - Provide maximum comfort for building occupants.
 - Improve operating efficiency of mechanical plant (boilers, chillers, cooling towers, etc.).

- Apply preventive maintenance procedures to reduce chances of premature equipment failures.
- Provide for periodic inspection of building systems to avoid emergency breakdown situations.
- **Develop and apply a screening process.** The screening process involves developing a series of questions specific to your site and expectations. The same set of questions should be asked to perspective contractors and their responses should be rated.
- **Select two to four potential contractors and obtain initial proposals based on each contractor's building assessments.** During the contractors' assessment process, communicate the objectives and expectations for the O&M service contract and allow each contractor to study the building documentation.
- **Develop the major contract requirements using the contractors' initial proposals.** Make sure to include the requirements for documentation and reporting. Contract requirements may also be developed by competent in-house staff or a third party.
- **Obtain final bids from the potential contractors based on the owner-developed requirements.**
- **Select the contractor and develop the final contract language and service plan.**
- **Manage and oversee the contracts and documentation.**
 - Periodically review the entire contract. Build in a feedback process.

3.9 References

Meador RJ. 1995. *Maintaining the Solution to Operations and Maintenance Efficiency Improvement*. World Energy Engineering Congress, Atlanta, Georgia.

PECI. 1997. *Energy Management Systems: A Practical Guide*. Portland Energy Conservation, Inc., Portland, Oregon.

Chapter 4 Computerized Maintenance Management System

4.1 Introduction

A computerized maintenance management system (CMMS) is a type of management software that performs functions in support of management and tracking of O&M activities.

4.2 CMMS Capabilities

CMMS systems automate most of the logistical functions performed by maintenance staff and management. CMMS systems come with many options and have many advantages over manual maintenance tracking systems. Depending on the complexity of the system chosen, typical CMMS functions may include the following:

- Work order generation, prioritization, and tracking by equipment/component.
- Historical tracking of all work orders generated which become sortable by equipment, date, person responding, etc.
- Tracking of scheduled and unscheduled maintenance activities.
- Storing of maintenance procedures as well as all warranty information by component.
- Storing of all technical documentation or procedures by component.
- Real-time reports of ongoing work activity.
- Calendar- or run-time-based preventive maintenance work order generation.
- Capital and labor cost tracking by component as well as shortest, median, and longest times to close a work order by component.
- Complete parts and materials inventory control with automated reorder capability.
- PDA interface to streamline input and work order generation.
- Outside service call/dispatch capabilities.

Many CMMS programs can now interface with existing energy management and control systems (EMCS) as well as property management systems. Coupling these capabilities allows for condition-based monitoring and component energy use profiles.

While CMMS can go a long way toward automating and improving the efficiency of most O&M programs, there are some common pitfalls. These include the following:

- **Improper selection of a CMMS vendor.** This is a site-specific decision. Time should be taken to evaluate initial needs and look for the proper match of system and service provider.
- **Inadequate training of the O&M administrative staff on proper use of the CMMS.** These staff need dedicated training on input, function, and maintenance of the CMMS. Typically, this training takes place at the customer's site after the system has been installed.

- **Lack of commitment to properly implement the CMMS.** A commitment needs to be in place for the start up/implementation of the CMMS. Most vendors provide this as a service and it is usually worth the expense.
- **Lack of commitment to persist in CMMS use and integration.** While CMMS provides significant advantages, they need to be maintained. Most successful CMMS installations have a “champion” of its use who ushers and encourages its continued use.

4.3 CMMS Benefits

One of the greatest benefits of the CMMS is the elimination of paperwork and manual tracking activities, thus enabling the building staff to become more productive. It should be noted that the functionality of a CMMS lies in its ability to collect and store information in an easily retrievable format. A CMMS does not make decisions, rather it provides the O&M manager with the best information to affect the *operational efficiency* of a facility.

Benefits to implement a CMMS include the following:

- Detection of impending problems before a failure occurs resulting in fewer failures and customer complaints.
- Achieving a higher level of planned maintenance activities that enables a more efficient use of staff resources.
- Affecting inventory control enabling better spare parts forecasting to eliminate shortages and minimize existing inventory.
- Maintaining optimal equipment performance that reduces downtime and results in longer equipment life.

As reported in A.T. Kearney's and *Industry Week's* survey of 558 companies that are currently using a computerized maintenance management system (DPSI 1994), companies reported an average of:

28.3% increase in maintenance productivity
20.1% reduction in equipment downtime
19.4% savings in lower material costs
17.8% reduction in MRO inventory
14.5 months average payback time.

4.4 Reference

DPSI. 1994. *Uptime for Windows Product Guide, Version 2.1*. DPSI, Greensboro, North Carolina.

Chapter 5 Types of Maintenance Programs

5.1 Introduction

What is maintenance and why is it performed? Past and current maintenance practices in both the private and Government sectors would imply that maintenance is the actions associated with equipment repair after it is broken. The dictionary defines maintenance as follows: “the work of keeping something in proper condition; upkeep.” This would imply that maintenance should be actions taken to prevent a device or component from failing or to repair normal equipment degradation experienced with the operation of the device to keep it in proper working order. Unfortunately, data obtained in many studies over the past decade indicates that most private and Government facilities do not expend the necessary resources to maintain equipment in proper working order. Rather, they wait for equipment failure to occur and then take whatever actions are necessary to repair or replace the equipment. Nothing lasts forever and all equipment has associated with it some pre-defined life expectancy or operational life. For example, equipment may be designed to operate at full design load for 5,000 hours and may be designed to go through 15,000 start and stop cycles.

The design life of most equipment requires periodic maintenance. Belts need adjustment, alignment needs to be maintained, proper lubrication on rotating equipment is required, and so on. In some cases, certain components need replacement, e.g., a wheel bearing on a motor vehicle, to ensure the main piece of equipment (in this case a car) last for its design life. Anytime we fail to perform maintenance activities intended by the equipment’s designer, we shorten the operating life of the equipment. But what options do we have? Over the last 30 years, different approaches to how maintenance can be performed to ensure equipment reaches or exceeds its design life have been developed in the United States. In addition to waiting for a piece of equipment to fail (reactive maintenance), we can utilize preventive maintenance, predictive maintenance, or reliability centered maintenance.

5.2 Reactive Maintenance

Reactive maintenance is basically the “run it till it breaks” maintenance mode. No actions or efforts are taken to maintain the equipment as the designer originally intended to ensure design life is reached. Studies as recent as the winter of 2000 indicate this is still the predominant mode of maintenance in the United States. The referenced study breaks down the average maintenance program as follows:

- >55% Reactive
- 31% Preventive
- 12% Predictive
- 2% Other.

Note that more than 55% of maintenance resources and activities of an average facility are still reactive.

Advantages to reactive maintenance can be viewed as a double-edged sword. If we are dealing with new equipment, we can expect minimal incidents of failure. If our maintenance program is purely reactive, we will not expend manpower dollars or incur capitol cost until something breaks.

Advantages

- Low cost.
- Less staff.

Disadvantages

- Increased cost due to unplanned downtime of equipment.
- Increased labor cost, especially if overtime is needed.
- Cost involved with repair or replacement of equipment.
- Possible secondary equipment or process damage from equipment failure.
- Inefficient use of staff resources.

Since we do not see any associated maintenance cost, we could view this period as saving money. The downside is reality. In reality, during the time we believe we are saving maintenance and capitol cost, we are really spending more dollars than we would have under a different maintenance approach. We are spending more dollars associated with capitol cost because, while waiting for the equipment to break, we are shortening the life of the equipment resulting in more frequent replacement. We may incur cost upon failure of the primary device associated with its failure causing the failure of a secondary device. This is an increased cost we would not have experienced if our maintenance program was more pro-

active. Our labor cost associated with repair will probably be higher than normal because the failure will most likely require more extensive repairs than would have been required if the piece of equipment had not been run to failure. Chances are the piece of equipment will fail during off hours or close to the end of the normal workday. If it is a critical piece of equipment that needs to be back on-line quickly, we will have to pay maintenance overtime cost. Since we expect to run equipment to failure, we will require a large material inventory of repair parts. This is a cost we could minimize under a different maintenance strategy.

5.3 Preventive Maintenance

Preventive maintenance can be defined as follows: Actions performed on a time- or machine-run-based schedule that detect, preclude, or mitigate degradation of a component or system with the aim of sustaining or extending its useful life through controlling degradation to an acceptable level.

The U.S. Navy pioneered preventive maintenance as a means to increase the reliability of their vessels. By simply expending the necessary resources to conduct maintenance activities intended by the equipment designer, equipment life is extended and its reliability is increased. In addition to an increase in reliability, dollars are saved over that of a program just using reactive maintenance. Studies indicate that this savings can amount to as much as 12% to 18% on the average.

Advantages

- Cost effective in many capital intensive processes.
- Flexibility allows for the adjustment of maintenance periodicity.
- Increased component life cycle.
- Energy savings.
- Reduced equipment or process failure.
- Estimated 12% to 18% cost savings over reactive maintenance program.

Disadvantages

- Catastrophic failures still likely to occur.
- Labor intensive.
- Includes performance of unneeded maintenance.
- Potential for incidental damage to components in conducting unneeded maintenance.

Depending on the facilities current maintenance practices, present equipment reliability, and facility downtime, there is little doubt that many facilities purely reliant on reactive maintenance could save much more than 18% by instituting a proper preventive maintenance program.

While preventive maintenance is not the optimum maintenance program, it does have several advantages over that of a purely reactive program. By performing the preventive maintenance as the equipment designer envisioned, we will extend the life of the equipment closer to design. This translates into dollar savings. Preventive maintenance (lubrication, filter change, etc.) will generally run the equipment more efficiently resulting in dollar savings. While we will not prevent equipment catastrophic failures, we will decrease the number of failures. Minimizing failures translate into maintenance and capital cost savings.

5.4 Predictive Maintenance

Predictive maintenance can be defined as follows: Measurements that detect the onset of a degradation mechanism, thereby allowing casual stressors to be eliminated or controlled prior to any significant deterioration in the component physical state. Results indicate current and future functional capability.

Basically, predictive maintenance differs from preventive maintenance by basing maintenance need on the actual condition of the machine rather than on some preset schedule. You will recall that preventive maintenance is time-based. Activities such as changing lubricant are based on time, like calendar time or equipment run time. For example, most people change the oil in their vehicles every 3,000 to 5,000 miles traveled. This is effectively basing the oil change needs on equipment run time. No concern is given to the actual condition and performance capability of the oil. It is changed because it is time. This methodology would be analogous to a preventive maintenance task. If, on the other hand, the operator of the car discounted the vehicle run time and had the oil analyzed at some periodicity to determine its actual condition and lubrication properties, he/she may be able to extend the oil change until the vehicle had traveled 10,000 miles. This is the fundamental difference between predictive maintenance and preventive maintenance, whereby predictive maintenance is used to define needed maintenance task based on quantified material/equipment condition.

Advantages

- Increased component operational life/availability.
- Allows for preemptive corrective actions.
- Decrease in equipment or process downtime.
- Decrease in costs for parts and labor.
- Better product quality.
- Improved worker and environmental safety.
- Improved worker moral.
- Energy savings.
- - Estimated 8% to 12% cost savings over predictive maintenance program.

Disadvantages

- Increased investment in diagnostic equipment.
- Increased investment in staff training.
- Savings potential not readily seen by management.

The advantages of predictive maintenance are many. A well-orchestrated predictive maintenance program will all but eliminate catastrophic equipment failures. We will be able to schedule maintenance activities to minimize or delete overtime cost. We will be able to minimize inventory and order parts, as required, well ahead of time to support the downstream maintenance needs. We can optimize the operation of the equipment, saving energy cost and increasing plant reliability. Past

studies have estimated that a properly functioning predictive maintenance program can provide a savings of 8% to 12% over a program utilizing preventive maintenance alone. Depending on a facility's reliance on reactive maintenance and material condition, it could easily recognize savings opportunities exceeding 30% to 40%. In fact, independent surveys indicate the following industrial average savings resultant from initiation of a functional predictive maintenance program:

- Return on investment: 10 times
- Reduction in maintenance costs: 25% to 30%
- Elimination of breakdowns: 70% to 75%
- Reduction in downtime: 35% to 45%
- Increase in production: 20% to 25%.

On the down side, to initially start into the predictive maintenance world is not inexpensive. Much of the equipment requires cost in excess of \$50,000. Training of in-plant personnel to effectively utilize predictive maintenance technologies will require considerable funding. Program development will require an understanding of predictive maintenance and a firm commitment to make the program work by all facility organizations and management.

5.5 Reliability Centered Maintenance

Reliability centered maintenance (RCM) magazine provides the following definition of RCM: “a process used to determine the maintenance requirements of any physical asset in its operating context.”

Basically, RCM methodology deals with some key issues not dealt with by other maintenance programs. It recognizes that all equipment in a facility is not of equal importance to either the process or facility safety. It recognizes that equipment design and operation differs and that different equipment

will have a higher probability to undergo failures from different degradation mechanisms than others. It also approaches the structuring of a maintenance program recognizing that a facility does not have unlimited financial and personnel resources and that the use of both need to be prioritized and optimized. In a nutshell, RCM is a systematic approach to evaluate a facility's equipment and resources to best mate the two and result in a high degree of facility reliability and cost-effectiveness. RCM is highly reliant on predictive maintenance but also recognizes that maintenance activities on equipment that is inexpensive and unimportant to facility reliability may best be left to a reactive maintenance approach. The following maintenance program breakdowns of

Advantages

- Can be the most efficient maintenance program.
- - Lower costs by eliminating unnecessary maintenance or overhauls.
- Minimize frequency of overhauls.
- Reduced probability of sudden equipment failures.
- - Able to focus maintenance activities on critical components.
- Increased component reliability.
- Incorporates root cause analysis.

Disadvantages

- - Can have significant startup cost, training, equipment, etc.
- Savings potential not readily seen by management.

continually top-performing facilities would echo the RCM approach to utilize all available maintenance approaches with the predominant methodology being predictive.

- <10% Reactive
- 25% to 35% Preventive
- 45% to 55% Predictive.

Because RCM is so heavily weighted in utilization of predictive maintenance technologies, its program advantages and disadvantages mirror those of predictive maintenance. In addition to these advantages, RCM will allow a facility to more closely match resources to needs while improving reliability and decreasing cost.

5.6 How to Initiate Reliability Centered Maintenance

The road from a purely reactive program to a RCM program is not an easy one. The following is a list of some basic steps that will help to get moving down this path.

1. Develop a Master equipment list identifying the equipment in your facility.
2. Prioritize the listed components based on importance to process.
3. Assign components into logical groupings.
4. Determine the type and number of maintenance activities required and periodicity using:
 - a. Manufacturer technical manuals
 - b. Machinery history
 - c. Root cause analysis findings - Why did it fail?
 - d. Good engineering judgment
5. Assess the size of maintenance staff.
6. Identify tasks that may be performed by operations maintenance personnel.
7. Analyze equipment failure modes and effects.
8. Identify effective maintenance tasks or mitigation strategies.

The references and resources provided below are by no means all-inclusive. The listed organizations are not endorsed by the authors of this guide and are provided for your information only. To locate additional resources, the authors of this guide recommend contacting relevant trade groups, databases, and the world-wide web.

An Introduction to Reliability and Maintainability Engineering

By: Charles E. Ebeling-

Published by: McGraw Hill College Division-

Publication date: September 1996-

Maintenance Engineering Handbook

By: Lindley R. Higgins, Dale P. Brautigam, and R. Keith Mobley (Editor)-
Published by: McGraw Hill Text, 5th Edition-
Publication date: September 1994-

Condition-Based Maintenance and Machine Diagnostics

By: John H. Williams, Alan Davies, and Paul R. Drake-
Published by: Chapman & Hall-
Publication date: October 1994-

Maintenance Planning and Scheduling Handbook

By: Richard D. (Doc) Palmer
Published by: McGraw Hill
Publication date: March 29, 1999

Maintainability and Maintenance Management

By: Joseph D. Patton, Jr.-
Published by: Instrument Society of America, 3rd Revision-
Publication date: February 1994-

Reliability-Centered Maintenance

By: John Moubray-
Published by: Industrial Press, 2nd Edition-
Publication date: April 1997-

Reliability-Centered Maintenance

By: Anthony M. Smith-
Published by: McGraw Hill-
Publication date: September 1992.-

Case Study Comparison of Four Maintenance Programs (Piotrowski 2001)

Reactive Maintenance (Breakdown or Run-to-Failure Maintenance)

Basic philosophy

- Allow machinery to run to failure.
- Repair or replace damaged equipment when obvious problems occur.

Cost: \$18/hp/yr

This maintenance philosophy allows machinery to run to failure, providing for the repair or replacement of damaged equipment only when obvious problems occur. Studies have shown that the costs to operate in this fashion are about \$18 per horsepower (hp) per year. The advantages of this approach are that it works well if equipment shutdowns do not affect production and if labor and material costs do not matter.

Preventive Maintenance (Time-Based Maintenance)

Basic philosophy

- Schedule maintenance activities at predetermined time intervals.
- Repair or replace damaged equipment before obvious problems occur.

Cost: \$13/hp/yr

This philosophy entails the scheduling of maintenance activities at predetermined time intervals, where damaged equipment is repaired or replaced before obvious problems occur. When it is done correctly, studies have shown the costs of operating in this fashion to be about \$13 per hp per year. The advantages of this approach are that it works well for equipment that does not run continuously, and with personnel who have enough knowledge, skills, and time to perform the preventive maintenance work.

Predictive Maintenance (Condition-Based Maintenance)

Basic philosophy

- Schedule maintenance activities when mechanical or operational conditions warrant.
- Repair or replace damaged equipment before obvious problems occur.

Cost: \$9/hp/yr

This philosophy consists of scheduling maintenance activities only if and when mechanical or operational conditions warrant-by periodically monitoring the machinery for excessive vibration, temperature and/or lubrication degradation, or by observing any other unhealthy trends that occur over time. When the condition gets to a predetermined unacceptable level, the equipment is shut down to repair or replace damaged components so as to prevent a more costly failure from occurring. In other words, "Don't fix what is not broke." Studies have shown that when it is done correctly, the costs to operate in this fashion are about \$9 per hp per year. Advantages of this approach are that it works very well if personnel have adequate knowledge, skills, and time to perform the predictive maintenance work, and that it allows equipment repairs to be scheduled in an orderly fashion. It also provides some lead-time to purchase materials for the necessary repairs, reducing the need for a high parts inventory. Since maintenance work is only performed when it is needed, there is likely to be an increase in production capacity.

Reliability Centered Maintenance (Pro-Active or Prevention Maintenance)

Basic philosophy

- - Utilizes predictive/preventive maintenance techniques with root cause failure analysis to detect and pinpoint the precise problems, combined with advanced installation and repair techniques, including potential equipment redesign or modification to avoid or eliminate problems from occurring.

Cost: \$6/hp/yr

This philosophy utilizes all of the previously discussed predictive/preventive maintenance techniques, in concert with root cause failure analysis. This not only detects and pinpoints precise problems that occur, but ensures that advanced installation and repair techniques are performed, including potential equipment redesign or modification, thus helping to avoid problems or keep them from occurring. According to studies, when it is done correctly, operating in this fashion costs about \$6 per hp per year. One advantage to this approach is that it works extremely well if personnel have the knowledge, skills, and time to perform all of the required activities. As with the predictive-based program, equipment repairs can be scheduled in an orderly fashion, but additional improvement efforts also can be undertaken to reduce or eliminate potential problems from repeatedly occurring. Furthermore, it allows lead-time to purchase materials for necessary repairs, thus reducing the need for a high parts inventory. Since maintenance work is performed only when it is needed, and extra efforts are put forth to thoroughly investigate the cause of the failure and determine ways to improve machinery reliability, there can be a substantial increase in production capacity.

5.7 Reference

Piotrowski J. April 2, 2001. *Pro-Active Maintenance for Pumps, Archives, February 2001*, Pump-Zone.com [Report online]. Available URL: <http://www.pump-zone.com>. Reprinted with permission of Pump-Zone.com.

Chapter 6 Predictive Maintenance Technologies

6.1 Introduction

Predictive maintenance attempts to detect the onset of a degradation mechanism with the goal of correcting that degradation prior to significant deterioration in the component or equipment.

The diagnostic capabilities of predictive maintenance technologies have increased in recent years with advances made in sensor technologies. These advances, breakthroughs in component sensitivities, size reductions, and most importantly, cost have opened up an entirely new area of diagnostics to the O&M practitioner.

As with the introduction of any new technology, proper application and **TRAINING** is of critical importance. This need is particularly true in the field of predictive maintenance technology that has become increasingly sophisticated and technology driven. Most industry experts would agree (as well as most reputable equipment vendors) that this equipment should not be purchased for in-house use if there is not a serious commitment to proper implementation, operator training, and equipment upkeep. If such a commitment cannot be made, a site is well advised to seek other methods of program implementation—a preferable option may be to contract for these services with an outside vendor and rely on their equipment and expertise.

6.2 Thermography

6.2.1 Introduction

Infrared (IR) thermography can be defined as the process of generating visual images that represent variations in IR radiance of surfaces of objects. Similar to the way objects of different materials and colors absorb and reflect electromagnetic radiation in the visible light spectrum (0.4 to 0.7 microns), any object at temperatures greater than absolute zero emits IR energy (radiation) proportional to its existing temperature. The IR radiation spectrum is generally agreed to exist between 2.0 and 15 microns. By using an instrument that contains detectors sensitive to IR electromagnetic radiation, a two-dimensional visual image reflective of the IR radiance from the surface of an object can be generated. Even though the detectors and electronics are different, the process itself is similar to that a video camera uses to detect a scene reflecting electromagnetic energy in the visible light spectrum, interpreting that information, and displaying what it detects on a liquid crystal display (LCD) screen that can then be viewed by the device operator.

Because IR radiation falls outside that of visible light (the radiation spectrum to which our eyes are sensitive), it is invisible to the naked eye. An IR camera or similar device allows us to escape the visible light spectrum and view an object based on its temperature and its proportional emittance of IR radiation. How and why is this ability to detect and visualize an object's temperature profile important in maintaining systems or components? Like all predictive maintenance technologies, IR tries to detect the presence of conditions or stressors that act to decrease a component's useful or design life. Many of these conditions result in changes to a component's temperature. For example, a loose or corroded electrical connection results in abnormally elevated connection temperatures due to increased electrical resistance. Before the connection is hot enough to result in equipment failure or possible fire, the patterns are easily seen through an IR imaging camera, the condition identified and corrected. Rotating equipment problems will normally result in some form of frictional change that will be seen as an increase in the component's temperature. Faulty or complete loss of refractory material will be readily seen as a change in the components thermal profile. Loss of a roof's membrane integrity will result in moisture that can be readily detected as differences in the roof thermal profile. These are just a few general examples of the hundreds of possible applications of this technology and how it might be used to detect problems that would otherwise go unnoticed until a component failed and resulted in excessive repair or downtime cost.

6.2.2 Types of Equipment

Many types of IR detection devices exist, varying in capability, design, and cost. In addition, simple temperature measurement devices that detect IR emissions but do not produce a visual image or IR profile are also manufactured. The following text and pictures provide an overview of each general instrument type.

Spot Radiometer (Infrared Thermometer) – Although not generally thought of in the world of thermography, IR thermometers use the same basic principles as higher end equipment to define an object's temperature based on IR emissions. These devices do not provide any image representative of an object's thermal profile, but rather a value representative of the temperature of the object or area of interest.



Figure 6.2.1. Typical IR spot thermometer.

Infrared Imager - As indicated earlier, equipment capabilities, design, cost, and functionality vary greatly. Differences exist in IR detector material, operation, and design. At the fundamental level, IR detection devices can be broken down into two main groups- imagers and cameras with radiometric capability. A simple IR imager has the ability to detect an object's IR emissions and translate this information into a visual image. It does not have the capability to analyze and quantify specific temperature values. This type of IR detection device can be of use when temperature values are unimportant and the object's temperature profile (represented by the image) is all that is needed to define a problem. An example of such an application would be in detecting missing or inadequate insulation in a structure's envelope. Such an application merely requires an image representative of the differences in the thermal profile due to absence of adequate insulation. Exact temperature values are unimportant.

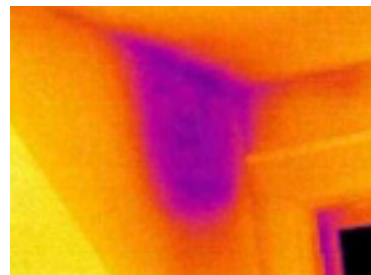

Figure 6.2.2. Internal house wall. Note dark area indicating cooler temperatures because of heat loss.

IR cameras with full radiometric capability detect the IR emissions from an object or camera field-of-view and translate this information into a visible format as in the case of an imager. In addition, these devices have the capability to analyze the image and provide temperature value for the area of interest. This capability is useful in applications where a temperature value is important in defining a problem or condition. For example, if an image indicated a difference between bearing

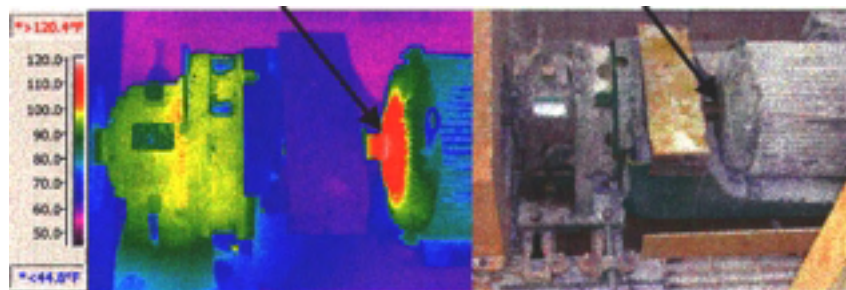

Figure 6.2.3. Hot motor bearing easily seen in IR image. Note the light area indicating a hot bearing.

housing temperature and the motor housing, it would be important in defining the problem to know the approximate temperature difference. This equipment and the supporting software can quantify temperatures anywhere within the IR image.

6.2.3 System Applications

6.2.3.1 Electrical System Applications

The primary value of thermographic inspections of electrical systems is locating problems so that they can be diagnosed and repaired. "How hot is it?" is usually of far less importance. Once the problem is located, thermography and other test methods, as well as experience and common sense, are used to diagnose the nature of the problem. The following list contains just a few of the possible electrical system-related survey applications:

- Transmission lines
 - Splices
 - Shoes/end bells
 - Inductive heating problems
 - Insulators
 - Cracked or damaged/tracking
- Distribution lines/systems
 - Splices
 - Line clamps
 - Disconnects
 - Oil switches/breakers
 - Capacitors

- Pole-mounted transformers
- Lightning arrestors
- Imbalances
- Substations
 - Disconnects, cutouts, air switches
 - Oil-filled switches/breakers (external and internal faults)
 - Capacitors
 - Transformers
 - Internal problems
 - Bushings
 - Oil levels
 - Cooling tubes
 - Lightning arrestors
 - Bus connections
- Generator Facilities
 - Generator
 - Bearings
 - Brushes
 - Windings
 - Coolant/oil lines: blockage
- Motors
 - Connections
 - Bearings
 - Winding/cooling patterns
 - Motor Control Center
 - Imbalances
- In-Plant Electrical Systems
 - Switchgear
 - Motor Control Center
 - Bus
 - Cable trays
 - Batteries and charging circuits
 - Power/Lighting distribution panels.

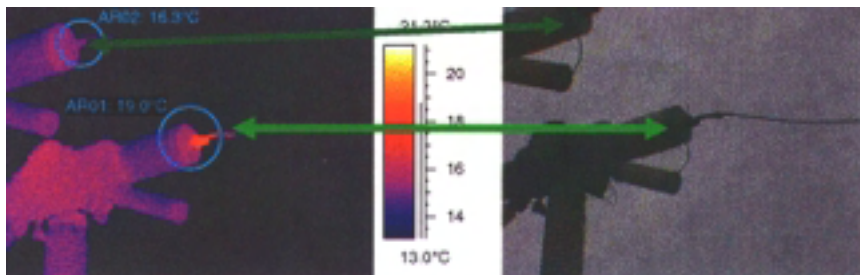

Figure 6.2.4. Air breaker problem. Note temperature difference between these air breaker contacts seen inside green circles.

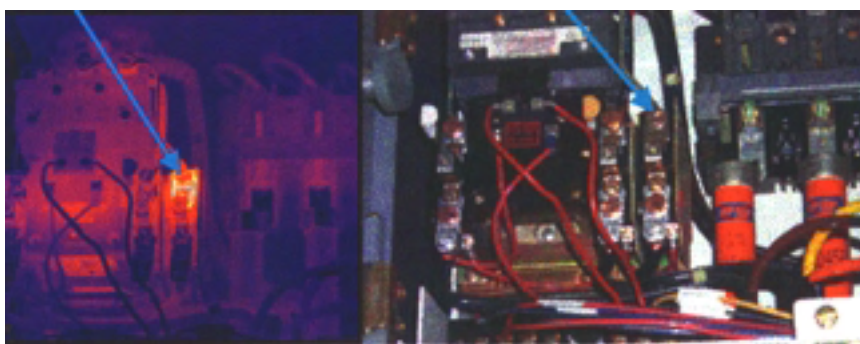

Figure 6.2.5. Overload connection problem. Note difference in IR image coloration between overload contacts.

6.2.3.2 Mechanical System Applications

Rotating equipment applications are only a small subset of the possible areas where thermography can be used in a mechanical predictive maintenance program. In addition to the ability to detect problems associated with bearing failure, alignment, balance, and looseness, thermography can be

used to define many temperature profiles indicative of equipment operational faults or failure. The following list provides a few application examples and is not all inclusive:

- Steam Systems
 - Boilers
 - Refractory
 - Tubes
 - Traps
 - Valves
 - Lines
- Heaters and furnaces
 - Refractory inspections
 - Tube restrictions
- Fluids
 - Vessel levels
 - Pipeline blockages
- Environmental
 - Water discharge patterns
 - Air discharge patterns
- Motors and rotating equipment
 - Bearings
 - Mechanical failure
 - Improper lubrication
 - Coupling and alignment problems
 - Electrical connections on motors
 - Air cooling of motors.

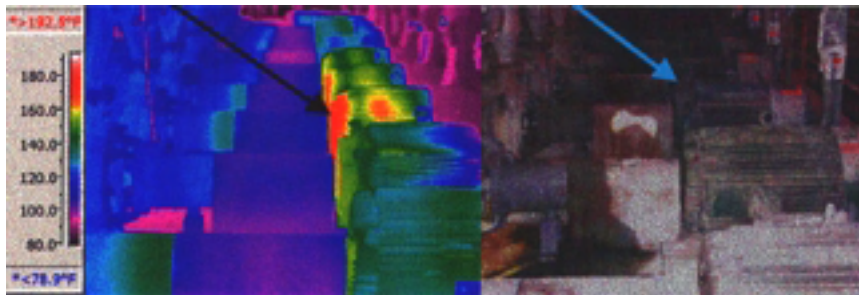

Figure 6.2.6. Warm inboard motor bearing. Image taken in a manner to readily compare IR images of several running motors.

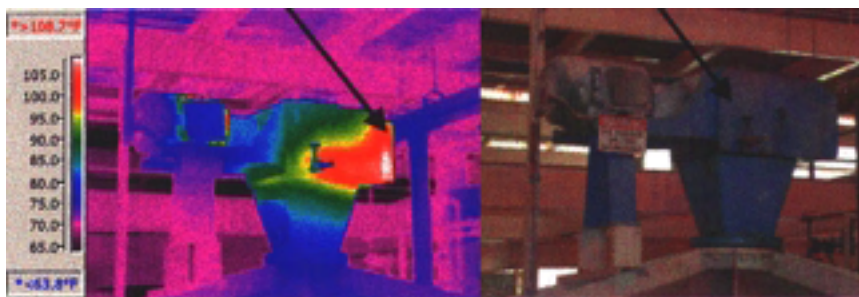

Figure 6.2.7. Possible gearbox problem indicated by white area defined by arrow. Design drawings of gearbox should be examined to define possible cause of elevated temperatures.

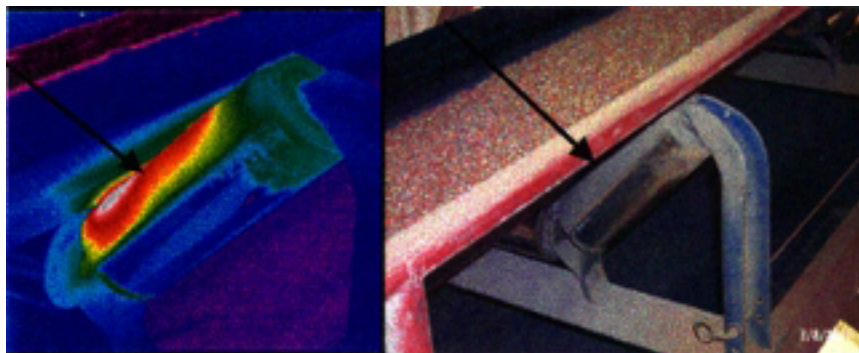

Figure 6.2.8. Seized conveyer belt roller as indicated by elevated temperatures in belt/roller contact area.



Figure 6.2.9. Inoperable steam heaters seen by cooler blue areas when compared to the operating heaters warmer red or orange colors.



Figure 6.2.10. Refractory breakdown readily seen by white area in IR image.

6.2.3.3 Roof Thermography

Out of sight, out of mind. This old adage is particularly true when it applies to flat roof maintenance. We generally forget about the roof until it leaks on our computers, switchgear, tables, etc. Roof replacement can be very expensive and at a standard industrial complex easily run into the hundreds of thousands of dollars. Depending on construction, length of time the roof has leaked, etc., actual building structural components can be damaged from inleakage and years of neglect that drive up repair cost further. Utilization of thermography to detect loss of a flat roof's membrane integrity is an application that can provide substantial return by minimizing area of repair/replacement. Roof reconditioning cost can be expected to run less than half of new roof cost per square foot. Add to this

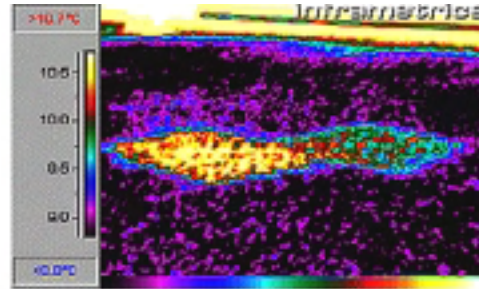
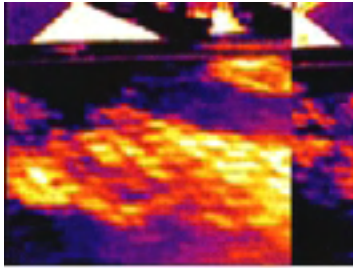

These images show elevated temperatures of roof insulation due to difference in thermal capacitance of moisture-laden insulation.

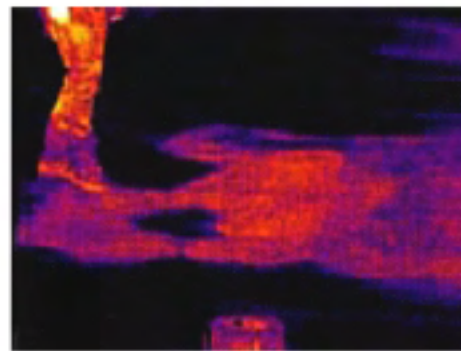

the savings to be gained from reconditioning a small percentage of the total roof surface, instead of replacement of the total roof, and the savings can easily pay for roof surveys and occasional repair for the life of the building with change left over.

6.2.4 Equipment Cost/Payback

As indicated earlier, the cost of thermography equipment varies widely depending on the capabilities of the equipment. A simple spot radiometer can cost from \$500 to \$2500. An IR imager without radiometric capability can range from \$12,000 to \$20,000. A camera with full functionality can cost from \$35,000 to \$65,000. Besides the camera hardware, other program costs are involved. Computer hardware, personnel training, manpower, etc., needs to be accounted for in the budget. Below is a listing of equipment and program needs recommended by a company recognized as a leader in the world of IR program development:

- Level I thermographic training
- Level II thermographic training
- Ongoing professional development
- IR camera with wide-angle, normal, and telephoto lenses
- Report software
- Laptop computer
- Color printer

- Digital visual camera
- Personal Protective Equipment (PPE) for arc flash protection
- \$80,000 IR camera and accessories
- \$8,000 Level I and II training
- \$45,000 - estimated annual loaded thermographer cost.

Payback can vary widely depending on the type of facility and use of the equipment. A production facility whose downtime equates to several thousands of dollars per hour can realize savings much faster than a small facility with minimal roof area, electrical distribution network, etc. On the average, a facility can expect a payback in 12 months or less. A small facility may consider using the services of an IR survey contractor. Such services are widely available and costs range from \$600 to \$1,200 per day. Contracted services are generally the most cost-effective approach for smaller, less maintenance-intensive facilities.

6.2.5 Case Studies

IR Diagnostics of Pump

A facility was having continual problems with some of its motor and pump combinations. Pump bearings repeatedly failed. An IR inspection confirmed that the lower thrust bearing was warmer than the other bearing in the pump. Further investigation revealed that the motor-pump combination was designed to operate in the horizontal position. In order to save floor space, the pump was mounted vertically below the motor. As a result, the lower thrust bearing was overloaded leading to premature failure. The failures resulted in a \$15,000 repair cost, not including lost production time (\$30,000 per minute production loss and in excess of \$600 per minute labor).

IR Diagnostics of Steam Traps

Steam trap failure detection can be difficult by other forms of detection in many hard to reach and inconvenient places. Without a good trap maintenance program, it can be expected that 15% to 60% of a facility's traps will be failed open. At \$3/1,000 lb (very conservative), a 1/4-in. orifice trap failed open will cost approximately \$7,800 per year. If the system had 100 traps and 20% were failed, the loss would be in excess of \$156,000. An oil refinery identified 14% of its traps were malfunctioning and realized a savings of \$600,000 a year after repair.

IR Diagnostics of Roof

A state agency in the northeast operated a facility with a 360,000 square foot roof area. The roof was over 22 years old and experiencing several leaks. Cost estimates to replace the roof ranged between \$2.5 and \$3 million. An initial IR inspection identified 1,208 square feet of roof requiring replacement at a total cost of \$20,705. The following year another IR inspection was performed that found 1,399 square feet of roof requiring replacement at a cost of \$18,217. A roof IR inspection program was started and the roof surveyed each year. The survey resulted in less than 200 square feet of roof identified needing replacement in any one of the following 4 years (one year results were as low as 30 square feet). The total cost for roof repair and upkeep for the 6 years was less than \$60,000. If the facility would have been privately owned, interest on the initial \$3 million at 10% would have amounted to \$300,000 for the first year alone. Discounting interest on \$3 million over the 5-year period, simple savings resulting from survey and repair versus initial replacement cost (\$3 million to

\$60,000) amount to \$2,940,000. This figure does not take into account interest on the \$3 million, which would result in savings in excess of another \$500,000 to \$800,000, depending on loan interest paid.

6.2.6 References/Resources

The references and resources provided below are by no means all-inclusive. The listed organizations are not endorsed by the authors of this guide and are provided for your information only. To locate additional resources, the authors of this guide recommend contacting relevant trade groups, databases, and the world-wide web.

FLIR Systems, Boston
16 Esquire Road
North Billerica, MA 01862
Telephone: (978) 901-8000

Indigo Systems Corporation
5385 Hollister Avenue #103
Santa Barbara, CA 93111
Telephone: (805) 964-9797
Fax: (805) 964-7708

Mikron Instrument Company, Inc.
16 Thornton Road
Oakland, NJ 07436
Telephone: (805) 964-9797

Raytheon Infrared
Customer Service
Telephone: (800) 990-3275 (International)
Telephone: (972) 344-4000 (U.S. only)
Email: infrared@raytheon.com

Nikon, Inc.
1300 Walt Whitman Road
Melville, NY 11747-3064
Telephone: (631) 547-4200,
1-800-52-Nikon, or (516) 547-4355 (Electronic)

6.2.6.1 Infrared Service Companies

Cooper Electric
3883 Virginia Avenue
Cincinnati, OH 46227
Telephone: (613) 271-6000
Fax: (613) 627-3246

Fox Systems, Inc.
1771 US Hwy 41 SW
P.O. Box 1777
Calhoun, GA 30703

Hartford Steam Boiler
Engineering Services
Telephone: (800) 231-0907, ext. 1120
Email: Sandy_Sanor@hsb.com

Infrared Services, Inc.
P.O. Box 701
Littleton, CO 80160-0701
Voice: (303) 734-1746
Fax: (303) 734-1201

Thermal Vision
14 Grissom Place
Pueblo, CO 81001
Telephone: (719) 646-4073
Email: fps@rmi.net

6.2.6.2 Infrared Internet Resource Sites

Academy of Infrared Thermography (www.infraredtraining.net)

- Level I, II, and III certification information and training schedule.
- Online store (books, software, videos).
- Online resources (links, image gallery, message board).
- Communication (classifieds, news, industry related information).
- Company profile and contact information.

Snell Infrared (Snellinfrared.com)

- Training and course information.
- Industry links.
- IR library.
- Newsletter.
- Classifieds.
- IR application information.

FLIR Systems (www.flir.com)

- Product information.
- Image gallery.
- Application overview with images.
- Used camera source.

6.3 Oil Analysis

6.3.1 Introduction

One of the oldest predictive maintenance technologies still in use today is that of oil analysis. Oil analysis is used to define three basic machine conditions related to the machine's lubrication or lubrication system. First is the condition of the oil, i.e., will its current condition lubricate per design? Testing is performed to determine lubricant viscosity, acidity, etc., as well as other chemical analysis to quantify the condition of oil additives like corrosion inhibitors. Second is the lubrication system condition, i.e., have any physical boundaries been violated causing lubricant contamination? By testing for water content, silicon, or other contaminants (depending on the system design), lubrication system integrity can be evaluated. Third is the machine condition itself. By analyzing wear particles existing in the lubricant, machine wear can be evaluated and quantified.

In addition to system degradation, oil analysis performed and trended over time can provide indication of improperly performed maintenance or operational practices. Introduction of contamination during lubricant change-out, improper system flush-out after repairs, addition of improper lubricant, and improper equipment operation are all conditions that have been found by the trending and evaluation of oil analysis data.

Several companies provide oil analysis services. These services are relatively inexpensive and some analysis laboratories can provide analysis results within 24 hours. Some services are currently using the Internet to provide quick and easy access to the analysis reports. Analysis equipment is also available should a facility wish to establish its own oil analysis laboratory. Regardless of whether the analysis is performed by an independent laboratory or by in-house forces, accurate results require proper sampling techniques. Samples should be taken from an active, low-pressure line, ahead of any filtration devices. For consistent results and accurate trending, samples should be taken from the same place in the system each time (using a permanently installed sample valve is highly recommended). Most independent laboratories supply sample containers, labels, and mailing cartons. If the oil analysis is to be done by a laboratory, all that is required is to take the sample, fill in information such as the machine number, machine type, and sample date, and send it to the laboratory. If the analysis is to be done on-site, analytical equipment must be purchased, installed, and standardized. Sample containers must be purchased, and a sample information form created and printed.

The most common oil analysis tests are used to determine the condition of the lubricant, excessive wearing of oil-wetted parts, and the presence of contamination. Oil condition is most easily determined by measuring viscosity, acid number, and base number. Additional tests can determine the presence and/or effectiveness of oil additives such as anti-wear additives, antioxidants, corrosion inhibitors, and anti-foam agents. Component wear can be determined by measuring the amount of wear metals such as iron, copper, chromium, aluminum, lead, tin, and nickel. Increases in specific wear metals can mean a particular part is wearing, or wear is taking place in a particular part of the machine. Contamination is determined by measuring water content, specific gravity, and the level of silicon. Often, changes in specific gravity mean that the fluid or lubricant has been contaminated with another type of oil or fuel. The presence of silicon (usually from sand) is an indication of contamination from dirt.

6.3.2 Test Types

- **Karl Fischer Water Test** – The Karl Fischer Test quantifies the amount of water in the lubricant.
Significance: Water seriously damages the lubricating properties of oil and promotes component corrosion. Increased water concentrations indicate possible condensation, coolant leaks, or process leaks around the seals.
- **ICP Spectroscopy** – Measures the concentration of wear metals, contaminant metals, and additive metals in a lubricant.
Significance: Measures and quantifies the elements associated with wear, contamination, and additives. This information assists decision makers in determining the oil and machine condition.
- **Particle Count** – Measures the size and quantity of particles in a lubricant.
Significance: Oil cleanliness and performance.
- **Viscosity Test** – Measure of a lubricant’s resistance to flow at a specific temperature.
Significance: Viscosity is the most important physical property of oil. Viscosity determination provides a specific number to compare to the recommended oil in service. An abnormal viscosity ($\pm 15\%$) is usually indicative of a problem.
- **FT-IR Spectroscopy** – Measures the chemical composition of a lubricant.
Significance: Molecular analysis of lubricants and hydraulic fluids by FT-IR spectroscopy produces direct information on molecular species of interest, including additives, fluid breakdown products, and external contamination.
- **Direct Read Ferrography** – Measures the relative amount of ferrous wear in a lubricant.
Significance: The direct read gives a direct measure of the amount of ferrous wear metals of different size present in a sample. Trending of this information reveals changes in the wear mode of the system.
- **Analytical Ferrography** – Allows analyst to visually examine wear particles present in a sample.
Significance: A trained analyst visually determines the type and severity of wear deposited onto the substrate by using a high magnification microscope. The particles are readily identified and classified according to size, shape, and metallurgy.
- **Total Acid Number** – Measures the acidity of a lubricant.
Description: Organic acids, a by-product of oil oxidation, degrade oil properties and lead to corrosion of the internal components. High acid levels are typically caused by oil oxidation.

6.3.3 Types of Equipment

Although independent laboratories generally perform oil analysis, some vendors do provide analysis equipment that can be used on-site to characterize oil condition, wear particles, and contamination. These devices are generally composed of several different types of test equipment and standards including viscometers, spectrometers, oil analyzers, particle counters, and microscopes. On-site testing can provide quick verification of a suspected oil problem associated with critical components such

as water contamination. It can also provide a means to quickly define lubricant condition to determine when to change the lubricant medium. For the most part, detailed analysis will still require the services of an independent laboratory.

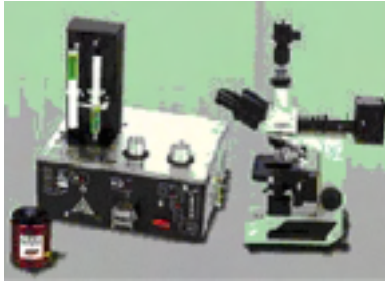

Typical oil analysis equipment available from several different vendors.



6.3.4 System Applications

- Turbines
- Boiler feed pumps
- Electrohydraulic control (EHC) systems
- Hydraulics
- Servo valves
- Gearboxes
- Roller bearings
- Anti-friction bearings
- Any system where oil cleanliness is directly related to longer lubricant life, decreased equipment wear, or improved equipment performance.

6.3.5 Equipment Cost/Payback

For facilities utilizing a large number of rotating machines that employ circulating lubricant, or for facilities with high dollar equipment using circulating lubricant, few predictive maintenance technologies can offer the opportunity of such a high return for dollars spent. Analysis for a single sample can run from \$6 to \$60 depending on the level of analysis requested. Given the high equipment replacement cost, labor cost, and downtime cost involved with a bearing or gearbox failure, a single failure prevented by the performance of oil analysis can easily pay for a program for several years.

6.3.6 Case Studies

Reduced Gear Box Failure

Through oil analysis, a company determined that each time oil was added to a gear reducer, contamination levels increased and this was accompanied by an increase in bearing and gear failures. Further examination determined that removing the cover plate to add oil allowed contamination from the process to fall into the sump. Based on this, the system was redesigned to prevent the introduction of contamination during oil addition. The result was a reduction in bearing/gearbox failure rates.

Oil Changes When Needed

A major northeast manufacturer switched from a preventive maintenance approach of changing oil in 400 machines using a time-based methodology to a condition-based method using in-house oil analysis. The oil is now being changed based on its actual condition and has resulted in a savings in excess of \$54,000 per year.

Oil Changes and Equipment Scheduling

A northeast industrial facility gained an average of 0.5 years between oil changes when it changed oil change requirements from a preventive maintenance time-based approach to changing oil based on actual conditions. This resulted in greater than a \$20,000 consumable cost in less than 9 months.

A large chemical manufacturing firm saved more than \$55,000 in maintenance and lost production cost avoidance by scheduling repair of a centrifugal compressor when oil analysis indicated water contamination and the presence of high ferrous and non-ferrous particle counts.

6.3.7 References/Resources

The references and resources provided below are by no means all-inclusive. The listed organizations are not endorsed by the authors of this guide and are provided for your information only. To locate additional resources, the authors of this guide recommend contacting relevant trade groups, databases, and the world-wide web.

6.3.7.1 Analysis Equipment Resources

Computational Systems, Inc.
835 Innovation Drive
Knoxville, TN 37932
Telephone: (865) 675-2110
Fax: (865) 218-1401

Reliability Direct, Inc.
2911 South Shore Boulevard, Suite 170
League City, TX 77573
Telephone: (281) 334-0766
Fax: (281) 334-4255

Predict/DLI
Atlanta, GA (770) 974-8440
Cleveland, OH (216) 642-3223
Houston, TX (713) 680-1555
Milwaukee, WI (262) 896-9764
Seattle, WA (206) 842-7656
Email: Predictdli.com

Spectro, Inc.
Industrial Tribology Systems
160 Ayer Road
Littleton, MA 01460-1103
Telephone: (978) 486-0123
Fax: (978) 486-0030
E-Mail: Info@SpectroInc.com

6.3.7.2 Oil Analysis Laboratories

Computational Systems, Inc.
835 Innovation Drive
Knoxville, TN 37932
Telephone: (865) 675-2110
Fax: (865) 218-1501

Analysts, Inc.
20505 Earl Street
Torrance, CA 90503
Telephone: (800) 336-3637
Fax: (310) 370-6637

LubeTrak
561 Keystone Avenue, Suite 103
Reno, NV 89503-5331
Telephone: 1-866-582-3872 (Toll Free)
Email: LubeTrak.com

PdMA Corporation
5909-C Hampton Oaks Parkway
Tampa, FL 33610
Telephone: (813) 621-6563
Fax: (813) 620-0206

6.3.7.3 Internet Resource Sites

www.testoil.com

- Sample report
- Free oil analysis
- Industry related articles
- Test overview
- Laboratory services
- Training services

www.compsys.com

- Laboratory service
- Technical articles

- Application papers
- Sample report
- Training services
- Technical notes

www.pdma.com

- Related articles
- Training material
- Analysis services
- Industry links

6.4 Ultrasonic Analysis

6.4.1 Introduction

Ultrasonic, or ultrasounds, are defined as sound waves that have a frequency level above 20 kHz. Sound waves in this frequency spectrum are higher than what can normally be heard by humans. Non-contact ultrasonic detectors used in predictive maintenance detect airborne ultrasound. The frequency spectrums of these ultrasounds fall within a range of 20 to 100 kHz. In contrast to IR emissions, ultrasounds travel a relatively short distance from their source. Like IR emissions, ultrasounds travel in a straight line and will not penetrate solid surfaces. Most rotating equipment and many fluid system conditions will emit sound patterns in the ultrasonic frequency spectrum. Changes in these ultrasonic wave emissions are reflective of equipment condition. Ultrasonic signature analysis can be used to identify problems related to component wear as well as fluid leaks, vacuum leaks, and steam trap failures. A compressed gas or fluid forced through a small opening creates turbulence with strong ultrasonic components on the downstream side of the opening. Even though such a leak may not be audible to the human ear, the ultrasound will still be detectable with a scanning ultrasound device.

Ultrasounds generated in vacuum systems are generated within the system. A small percentage of these ultrasonic waves escape from the vacuum leak and are detectable, provided the monitoring is performed close to the source or the detector gain is properly adjusted to increase detection performance. In addition to system vacuum or fluid leaks, ultrasonic wave detection is also useful in defining abnormal conditions generated within a system or component. Poorly seated valves (as in the case of a failed steam trap) emit ultrasounds within the system boundaries as the fluid leaks past the valve seat (similar to the sonic signature generated if the fluid was leaking through the pipe or fitting walls). These ultrasounds can be detected using a contact-type ultrasonic probe.

Ultrasonic detection devices can also be used for bearing condition monitoring. According to National Aeronautics and Space Administration (NASA) research, a 12-50x increase in the amplitude of a monitored ultrasonic frequency (28 to 32 kHz) can provide an early indication of bearing deterioration.

Ultrasonic detection devices are becoming more widely used in detection of certain electrical system anomalies. Arcing/tracking or corona all produce some form of ionization that disturbs the air molecules around the equipment being diagnosed and produces some level of ultrasonic signature. An ultrasonic device can detect the high-frequency noise produced by this effect and translate it, via heterodyning, down into the audible ranges. The specific sound quality of each type of emission is heard in headphones while the intensity of the signal can be observed on a meter to allow quantification of the signal.

6.4.2 Types of Equipment

Ultrasonic analysis is one of the less complex and less expensive predictive maintenance technologies. The equipment is relatively small, light, and easy to use. Measurement data is presented in a straightforward manner using meters or digital readouts. The cost of the equipment is moderate and the amount of training is minimal when compared to other predictive maintenance technologies. The picture to the right shows a typical ultrasonic detection device.



Typical handheld ultrasonic detector.

Since ultrasounds travel only a short distance, some scanning applications could present a safety hazard to the technician or the area of interest may not be easily accessible. In these applications, the scanning device is generally designed with a gain adjust to increase its sensitivity, thereby allowing scanning from a greater distance than normal. Some ultrasonic detectors are designed to allow connection of a special parabolic dish-type sensing device (shown at left) that greatly extends the normal scanning distance.



Parabolic dish used with ultrasonic detector greatly extends detection range abilities.

6.4.3 System Applications

6.4.3.1 Pressure/Vacuum Leaks

- Compressed air
- Oxygen
- Hydrogen, etc.
- Heat exchangers
- Boilers
- Condensers
- Tanks
- Pipes
- Valves
- Steam traps.

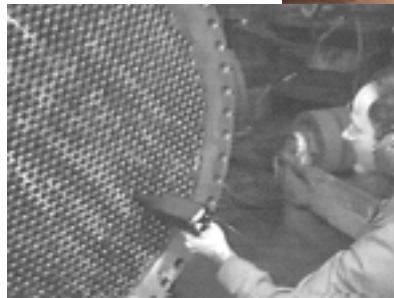

Ultrasonic detection can be used to locate underground system leaks and detect heat exchanger tube leakage.

6.3.3.2 Mechanical Applications

- Mechanical inspection
- Bearings
- Lack of lubrication
- Pumps
- Motors
- Gears/Gearboxes
- Fans
- Compressors
- Conveyers.



From steam trap faults and valve leakage to compressor problems, ultrasonic detection can be used to find a variety of problems that generate ultrasonic signatures.

6.4.3.3 Electrical Applications

- Arcing/tracking/corona
- Switchgear
- Transformers
- Insulators
- Potheads
- Junction boxes
- Circuit breakers.



Mechanical devices are not the only sources of ultrasonic emission. Electrical equipment will also generate ultrasonic waves if arcing/tracking or corona are present.

6.4.4 Equipment Cost/Payback

As indicated earlier, ultrasonic analysis equipment cost is minimal when compared to other predictive maintenance technologies. A hand-held scanner, including parabolic dish, software, probes, etc., will cost from \$1,000 to \$12,000. The minimal expense combined with the large savings opportunities will most often result in an equipment payback period of 6 months or less.

6.4.5 Case Studies

Ultrasound Detects Compressed Air Leaks

A northeast industrial plant was experiencing some air problems. The facility's two compressors were in the on mode for an inordinate amount of time, and plant management assumed a third compressor was needed, at a cost of \$50,000. Instead, the foundry invested less than \$1,000 in contracting an outside firm to perform an ultrasound inspection of its air system. In a single day, the ultrasound technician detected 64 air leaks accounting for an estimated total air loss of 295.8 cfm (26% of total system capacity). Considering it cost approximately \$50,014 per year (calculated at \$.04/kilowatt/hour) to operate the two air compressors, at a total of 1,120 cfm, correcting this air loss saved the plant \$13,000 per year. In addition, the plant avoided having to spend another \$50,000 on another air compressor, because after the leaks were found and repaired, the existing compressors were adequate to supply demand.

A Midwest manufacturer saved an estimated \$75,900 in annual energy costs as a result of an ultrasound survey of its air system. A total of 107 air leaks were detected and tagged for repair. These leaks accounted for an air loss of 1,031 cfm, equal to 16% of the total 6,400 cfm produced by the air compressors that supply the facility.

6.4.6 References/Resources

The references and resources provided below are by no means all-inclusive. The listed organizations are not endorsed by the authors of this guide and are provided for your information only. To locate additional resources, the authors of this guide recommend contacting relevant trade groups, databases, and the world-wide web.

6.4.6.1 Equipment Resources

UE Systems

14 Hayes Street
Elmsford, NY 10523
Telephone: (914) 592-1220
Fax: (914) 347-2181

CTRL Systems, Inc.

1004 Littlestown Pike, Suite H
Westminster, MD 21157
Telephone: (877) 287-5797

Specialized Diagnostic Technologies, Inc.

8711A-50th Street, Suite 202
Edmonton, Alberta
T6B 1E7
Telephone: (780) 440-1362
Fax: (780) 440-0373
Email: sdtwest@sdt-canada.com

Superior Signal Company

P.O. Box 96
Spotswood, NJ 08884
Telephone: 1-800-945-TEST(8378) or
(732) 251-0800
Fax: (732) 251-9442

6.4.6.2 Service Companies

Plant Support and Evaluations, Inc.

2921 South 160th Street
New Berlin, WI 53151
Telephone: 1-888-615-3559

Mid-Atlantic Infrared Services, Inc.

5309 Mohican Road
Bethesda, MD 21270
Telephone: (301) 320-2870

PMCI

2500 Estes Avenue
Elk Grove Village, IL 60007
Telephone: 1-800-222-PMCI

UE Systems, Inc.

Telephone: (914) 592-1220 or 1-800-223-1325
(Toll Free)
Fax: (914) 347-2181
Email: info@uesystems.com

6.4.6.3 Internet Resource Sites

www.uesystems.com

- Technology overview
- Training
- Links
- Sound demos.

www.superiorsignal.com

- Technology overview
- Ultrasonic sound bites (examples)
- Ultrasonic spectral graphs.

6.5 Vibration Analysis

6.5.1 Introduction

As all of us who ride or drive an automobile with some regularity know, certain mechanical faults or problems produce symptoms that can be detected by our sense of feel. Vibrations felt in the steering wheel can be an indicator of an out-of-balance wheel or looseness in the steering linkage. Transmission gear problems can be felt on the shift linkage. Looseness in exhaust system components can sometimes be felt as vibrations in the floorboard. The common thread with all these problems is that degeneration of some mechanical device beyond permissible operational design limitations has manifested itself by the generation of abnormal levels of vibration. What is vibration and what do we mean by levels of vibration? The dictionary defines vibration as “a periodic motion of the particles of an elastic body or medium in alternately opposite directions from the position of equilibrium when that equilibrium has been disturbed or the state of being vibrated or in vibratory motion as in (1) oscillation or (2) a quivering or trembling motion.”

The key elements to take away from this definition are one: vibration is motion. Second, this motion is cyclic around a position of equilibrium. How many times have you touched a machine to see if it was running? You are able to tell by touch if the motor is running because of vibration generated by motion of rotational machine components and the transmittal of these forces to the machine housing. Many parts of the machine are rotating and each one of these parts is generating its own distinctive pattern and level of vibration. The level and frequency of these vibrations are different and the human touch is not sensitive enough to discern these differences. This is where vibration detection instrumentation and signature analysis software can provide us the necessary sensitivity. Sensors are used to quantify the magnitude of vibration or how rough or smooth the machine is running. This is expressed as vibration amplitude. This magnitude of vibration is expressed as:

- **Displacement** – The total distance traveled by the vibrating part from one extreme limit of travel to the other extreme limit of travel. This distance is also called the “peak-to-peak displacement.”
- **Velocity** – A measurement of the speed at which a machine or machine component is moving as it undergoes oscillating motion.
- **Acceleration** – The rate of change of velocity. Recognizing that vibrational forces are cyclic, both the magnitude of displacement and velocity change from a neutral or minimum value to some maximum. Acceleration is a value representing the maximum rate that velocity (speed of the displacement) is increasing.

Various transducers are available that will sense and provide an electrical output reflective of the vibrational displacement, velocity, or acceleration. The specific unit of measure to best evaluate the machine condition will be dependent on the machine speed and design. Several guidelines have been published to provide assistance in determination of the relative running condition of a machine. An example is seen in Figure 6.5.1. It should be said that the values defined in this guideline, or similar guidelines, are not absolute vibration limits above which the machine will fail and below which the machine will run indefinitely. It is impossible to establish absolute vibration limits. However, in setting up a predictive maintenance program, it is necessary to establish some severity criteria or limits above which action will be taken. Such charts are not intended to be used for establishing vibration acceptance criteria for rebuilt or newly installed machines. They are to be used to evaluate the general or overall condition of machines that are already installed and operating in service. For those, setting up a predictive maintenance program, lacking experience or historical data, similar charts can serve as an excellent guide to get started.

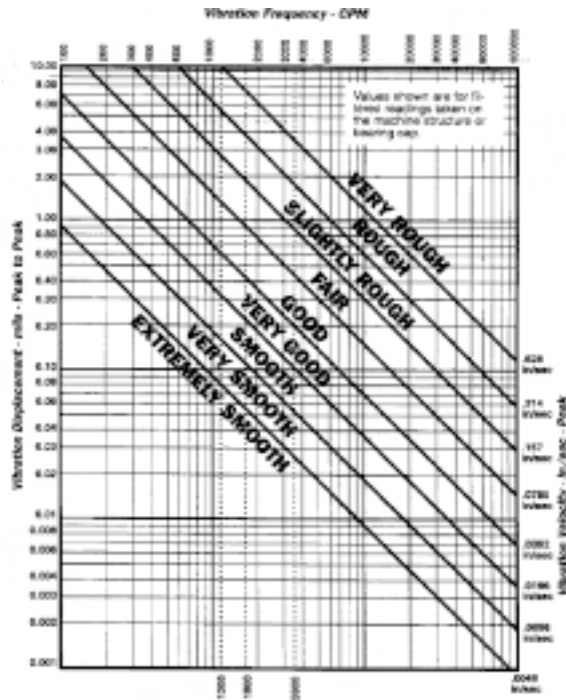

Figure 6.5.1. Vibration severity chart.

of the machine, on-line monitoring versus off-line data collection, analysis needs, signal output requirements, etc., will affect the type of equipment options available. Regardless of the approach, any vibration program will require a sensing device (transducer) to measure the existing vibration and translate this information into some electronic signal. Transducers are relatively small in size (see Figure 6.5.3) and can be permanently mounted or affixed to the monitoring location periodically during data collection.



Figure 6.5.3. Typical vibration transducers.

As indicated earlier, many vibration signals are generated at one time. Once a magnitude of vibration exceeds some predetermined value, vibration signature analysis can be used in defining the machine location that is the source of the vibration and in need of repair or replacement. By using analysis equipment and software, the individual vibration signals are separated out and displayed in a manner that defines the magnitude of vibration and frequency (Figure 6.5.2). With the understanding of machine design and operation, an individual schooled in vibration signature analysis can interpret this information to define the machine problem to a component level.

6.5.2 Types of Equipment

Depending on the application, a wide variety of hardware options exist in the world of vibration. Although not complicated, actual hardware requirements depend on several factors. The speed

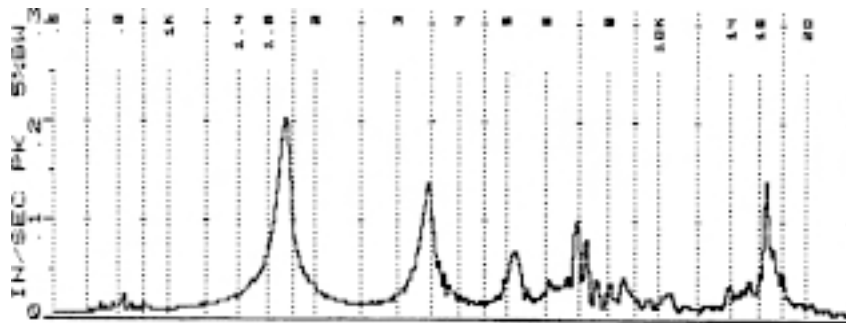

Figure 6.5.2. FFT - Example of graph breaking down vibration level at different frequencies

In some cases, the actual translation of the vibration to an electrical signal occurs in a hand-held monitoring device. A metal probe attached to a hand-held instrument is held against a point of interest and the instrument translates the motions felt on the probe to some sort of electrical signal. Other portable devices utilize a transducer and hand-held data collection device. Both styles will provide some sort of display where the vibration magnitude is defined. Styles and equipment size vary greatly, but equipment is designed to be portable.



Examples of typical handheld vibration sensing meters. Note readout providing immediate level indication.



In addition to instruments designed to measure vibration magnitude, many manufacturers provide instrumentation that will perform signal analysis as well. Some equipment is designed to perform this analysis in the field while other equipment designs may require the use of an external PC.



Typical Vibration Analyzer – Note liquid crystal display providing actual vibration waveform information in addition to machine condition analytical capabilities.

6.5.3 System Applications

Vibration monitoring and analysis can be used to discover and diagnose a wide variety of problems related to rotating equipment. The following list provides some generally accepted abnormal equipment conditions/faults where this predictive maintenance technology can be of use in defining existing problems:

- Unbalance
- Eccentric rotors
- Misalignment
- Resonance problems
- Mechanical looseness/weakness
- Rotor rub
- Sleeve-bearing problems
- Rolling element bearing problems
- Flow-induced vibration problems
- Gear problems
- Electrical problems
- Belt drive problems.

Analyzing equipment to determine the presence of these problems is not a simple and easily performed procedure. Properly performed and evaluated vibration signature analysis requires highly trained and skilled individuals, knowledgeable in both the technology and the equipment being tested. Determination of some of the problems listed is less straightforward than other problems and may require many hours of experience by the technician to properly diagnosis the condition.

6.5.4 Equipment Cost/Payback

As indicated earlier, the styles, types, and capabilities of vibration monitoring equipment vary greatly. Naturally, equipment cost follows this variance. Transducers can cost under \$100. The expected cost for vibration metering devices capable of defining magnitude with no analysis capability is approximately \$1000. The cost goes up from there. A high-end vibration analyzer with software and all the accessories can exceed \$50,000. A typical industrial site can expect to recover the cost of the high-end equipment investment within 2 years. Sites with a minimal number of rotating equipment, low-cost equipment installations, and/or no production related concerns may find it uneconomically advantageous to purchase a \$50,000 vibration analysis system. These facilities may be wise to establish an internal program of vibration monitoring using a low-cost vibration-metering device and then employ the services of an outside contractor to conduct periodic surveys. These services generally range in cost from \$600 to \$1200 per day.

6.5.5 Case Studies

Vibration Analysis on Pump

Vibration analysis on a 200-hp motor/pump combination resulted in determination of improperly sized shaft bearings on both the pump end and the motor end. Repair costs were less than \$2,700. Continued operation would have led to failure and a replacement cost exceeding \$10,000.

6.5.6 References/Resources

The references and resources provided below are by no means all-inclusive. The listed organizations are not endorsed by the authors of this guide and are provided for your information only. To locate additional resources, the authors of this guide recommend contacting relevant trade groups, databases, and the world-wide web.

6.5.6.1 Equipment Resources

Wilcoxon Research, Inc.

21 Firstfield Road
Gaithersburg, MD 20878
Telephone: (301) 330-8811 or
1-800-WILCOXON
Email: sensors@wilcoxon.com
Web site: www.wilcoxon.com

Bently Nevada Corporation

1631 Bently Parkway South
Minden, NV 89423
Telephone: (775) 782-3611

SKF Condition Monitoring

4141 Ruffin Road
San Diego, CA 92123
Telephone: (858) 496-3400
Fax: (858) 496-3531

Computational Systems, Inc.

835 Innovation Drive
Knoxville, TN 37932
Telephone: (865) 675-2110
Fax: (865) 218-1401

6.5.6.2 Service Companies

Industrial Research Technology

Bethlehem, PA - Pittsburgh, PA -
Cleveland, OH - Detroit, MI - Chicago, IL -
Charleston, SC
Telephone: (610) 867-0101 or
1-800-360-3594
Fax: (610) 867-2341

Computational Systems, Inc.

835 Innovation Drive
Knoxville, TN 37932
Telephone: (865) 675-2110
Fax: (865) 218-1401

VibrAlign

530G Southlake Boulevard
Richmond, VA 23236
Voice: (804) 379-2250
Fax: (804) 379-0189
Toll Free: 800-394-3279
Email: info@vibralign.com

SKF Condition Monitoring

4141 Ruffin Road
San Diego, CA 92123
Telephone: (858) 496-3400
Fax: (858) 496-3531

6.5.6.3 Internet Resource Sites

Plant-maintenance.com

- Training material
- Industry links
- Free software
 - FFT/CMMS/Inventory control
- Technical articles
- Maintenance related articles

www.bksv.com/bksv/

- Products
- Industry articles
- Links

www.skfusa.com

- References and links
- Articles
- Products
- Training.

6.6 Motor Analysis

6.6.1 Introduction

When it comes to motor condition analysis, infrared (IR) and vibration will not provide all the answers required to properly characterize motor condition. Over the past several years, motor condition analysis techniques have evolved from simple meggering and hi-pot testing into testing techniques that more accurately define a motor's condition. Motor faults or conditions like winding short-circuits, open coils, improper torque settings, as well as many mechanically related problems can be diagnosed using motor analysis techniques. Use of these predictive maintenance techniques and technologies to evaluate winding insulation and motor condition has not grown as rapidly as other predictive techniques. Motor analysis equipment remains fairly expensive and proper analysis requires a high degree of skill and knowledge. Recent advances in equipment portability and an increase in the number of vendors providing contracted testing services continue to advance predictive motor analysis techniques. Currently, more than 20 different types of motor tests exist, depending on how the individual tests are defined and grouped. The section below provides an overview of two commonly used tests.

6.6.2 Motor Analysis Test

6.6.2.1 Electrical Surge Comparison

In addition to ground wall insulation resistance, one of the primary concerns related to motor condition is winding insulation. Surge comparison testing can be used to identify turn-to-turn and phase-to-phase insulation deterioration, as well as a reversal or open circuit in the connection of one or more coils or coil groups. Recent advances in the portability of test devices now allow this test technique to be used in troubleshooting and predictive maintenance. Because of differences in insulation thickness, motor winding insulation tends to be more susceptible to failure from the inherent stresses existing within the motor environment than ground wall insulation. Surge comparison testing identifies insulation deterioration by applying a high frequency transient surge to equal parts of a winding and comparing the resulting voltage waveforms. Differences seen in the resulting waveforms are indicative insulation or coil deterioration. A properly trained test technician can use these differences to properly diagnose the type and severity of the fault. In addition to utilization of this motor analysis technique in a predictive maintenance program, it can also be used to identify improper motor repair practices or improper operating conditions (speeds, temperature, load).

Surge comparison testing is a moderately complex and expensive predictive maintenance technique. As with most predictive maintenance techniques, the greatest saving opportunities do not come directly from preventing a catastrophic failure of a component (i.e., motor) but rather the less tangible cost saving benefits. Reduced downtimes, ability to schedule maintenance, increased production, decreased overtime, and decreased inventory cost are just a few of the advantages of being able to predict an upcoming motor failure.

6.6.2.2 Motor Current Signature Analysis

Another useful tool in the motor predictive maintenance arsenal is motor current signature analysis (MCSA). MCSA provides a non-intrusive method for detecting mechanical and electrical problems in motor-driven rotating equipment. The technology is based on the principle that a conventional electric motor driving a mechanical load acts as a transducer. The motor (acting as a transducer)

senses mechanical load variations and converts them into electric current variations that are transmitted along the motor power cables. These current signatures are reflective of a machine's condition and closely resemble signatures produced using vibration monitoring. These current signals are recorded and processed by software to produce a visual representation of the existing frequencies against current amplitude. Analysis of these variations can provide an indication of machine condition, which may be trended over time to provide an early warning of machine deterioration or process alteration.

Motor current signature analysis is one of the moderately complex and expensive predictive techniques. The complexity stems in large part from the relatively subjective nature of interpreting the spectra, and the limited number of industry-wide historical or comparative spectra available for specific applications.

6.6.3 System Applications

- Stem packing degradation
- Incorrect torque switch settings
- Degraded stem or gear case lubrication
- Worn gear tooth wear
- Restricted valve stem travel
- Obstructions in the valve seat area
- Disengagement of the motor pinion gear
- Improper seal/packing installation
- Improper bearing or gear installation
- Inaccurate shaft alignment or rotor balancing
- Insulation deterioration
- Turn-to-turn shorting
- Phase-to-phase shorting
- Short circuits
- Reversed or open coils.

6.6.4 Equipment Cost/Payback

As indicated earlier, motor analysis equipment is still costly and generally requires a high degree of training and experience to properly diagnosis equipment problems. A facility with a large number of motors critical to process throughput may find that ownership of this technology and adequately trained personnel more than pays for itself in reduced downtime, overtime cost, and motor inventory needs. Smaller facilities may find utilization of one of the many contracted service providers valuable in defining and maintaining the health of the motors within their facility. As with most predictive maintenance contract services, cost will range from \$600 to \$1,200 per day for on-site support. Finding a single motor problem whose failure would result in facility downtime can quickly offset the cost of these services.

6.6.5 References/Resources

The references and resources provided below are by no means all-inclusive. The listed organizations are not endorsed by the authors of this guide and are provided for your information only. To locate additional resources, the authors of this guide recommend contacting relevant trade groups, databases, and the world-wide web.

6.6.5.1 Equipment Resources

Computational Systems, Inc.

835 Innovation Drive
Knoxville, TN 37932
Telephone: (865) 675-2110
Fax: (865) 218-1401

Chauvin Arnoux® , Inc.Ä

d.b.a. AEMC® Instruments
200 Foxborough Boulevard
Foxborough, MA 02035
Telephone: (508) 698-2115 or (800) 343-1391
Fax: (508) 698-2118
Email: sales@aemc.com

AVO International

4651 S. Westmoreland Road
Dallas, TX 75237-1017
Telephone: (800) 723-2861
Fax: (214) 333-3533

Baker Instrument Company

4812 McMurry Avenue
Fort Collins, CO 80525
Telephone: (970) 282-1200 or (800) 752-8272
Fax: (970) 282-1010

6.6.5.2 Service Companies

Industrial Technology Research

Bethlehem, PA - Pittsburgh, PA -
Cleveland, OH - Detroit, MI - Chicago, IL -
Charleston, SC - Hamilton, ONT
Telephone: (610) 867-0101 or (800) 360-3594
Fax: (610) 867-2341

Littlejohn-Reuland Corp.

4575 Pacific Boulevard
Vernon, CA 90058
Telephone: (323) 587-5255
Fax: (323) 581-8385

Tru-Tec Services, Inc.

Magna-Tec

Telephone: (800) 232-8411

UE Amarillo

5601 W. Interstate 40
Amarillo, TX 79106-4605
Telephone: (806) 359-2400
Fax: (806) 359-2499

SHERMCO Industries, Inc.

Dallas
2425 East Pioneer Drive
Irving, TX 75061
Telephone: (972) 793-5523 or 1-888-SHERMCO
(Toll Free)
Fax: (972) 793-5542

6.6.5.3 Internet Site Resources

www.ic.ornl.gov

- On-line analysis system information
- Technology information contact resources

www.mt-online.com

- Technology overview
- Technology vendors
- Industry articles

www.reliabilityweb.com

- Service companies
- Training services
- Software links (including Motor Master)

6.7 Performance Trending

6.7.1 Introduction

In addition to the general preventive maintenance we perform, or have performed on our vehicles, many of us log and trend important parametric information related to the health of our vehicles and use this information to determine maintenance needs. We calculate and trend our cars mileage per gallon of gas. We track engine temperature and oil pressure. We track oil usage. This information is then used to define when vehicle maintenance is required. Maintenance activities such as tune-ups, thermostat replacement, cooling system flushes, belt replacements, oil seal replacements, etc., may all be originally stimulated by vehicle parametric information we trend.

Utilization of this performance trending approach can also be a valuable tool in maintaining the health and operational performance of the components in our facilities/plants. By logging and trending the differential pressure across a supply or discharge filter in the HVAC system, we can determine when filter replacement is required, rather than changing the filter out at some pre-defined interval (preventive maintenance). Logging and trending temperature data can monitor the performance of many heat exchangers. This information can be used to assist in the scheduling of tube cleaning. It may also serve as an indication that flow control valves are not working properly or chemical control measures are inadequate. Perhaps a decrease in heat exchanger performance, as seen by a change in delta-temperature, is due to biological fouling at our cooling loop pump suction. An increase in boiler stack temperature might be an indication of tube scaling. We may need to perform tube cleaning and adjust our chemistry control measures. Changes in combustion efficiency may be indicative of improperly operating oxygen trim control, fuel flow control, air box leakage, or tube scaling.

The key idea of performance trending is that much of the equipment installed in our facilities is already provided with instrumentation that can be used to assist in determination of the health/condition of the related component. Where the instruments are not present, installation of a pressure-sensing or temperature-sensing device is generally easily performed and inexpensive. Many times this information is already being logged at some pre-defined interval but not being utilized.

6.7.2 How to Establish a Performance Trending Program

One of the first steps of any predictive maintenance program is to know what equipment exists in your facility. First, generate a master equipment list, then prioritize the equipment on the list to define which pieces of equipment are critical to your facility's operation, important to personnel safety, or can have a significant budget impact (either through failure or inefficient operation).

Evaluate what parametric data should/could be easily collected from installed or portable instrumentation to provide information related to the condition/performance of the equipment on the master list based on your equipment prioritization.

Determine what, if any, of the defined data is already collected. Evaluate if any related parametric information is currently being tracked and if that information provides information regarding a components/systems condition or efficiency. Terminate the collection of information not useful in the evaluation of a component's condition/efficiency unless required by other administrative requirements.

Define and install instrumentation not currently available to monitor a critical component's condition/efficiency.

Log the information at some frequency defined by plant engineering or operational staff. For example, the frequency may be every 4 hours while operating or may simply be a single reading after reaching steady-state conditions, depending on the data evaluation needs.

Provide collected data to individual with knowledge and background necessary to properly trend and evaluate it.

6.7.3 System Applications

Generally, any plant component with installed, or easily installed, instrumentation useful in evaluating the components condition, operation, or efficiency can be trended. Information can also be obtained using portable instrumentation, e.g., an infrared thermometer. Some general applications might be:

- Heat exchangers
- Filters
- Pumps
- HVAC equipment
- Compressors
- Diesel/gasoline engines
- Boilers.

6.7.4 Equipment Cost/Payback

The cost to establish an effective trending program is minimal and can provide one of the largest returns on dollars expended. Most plants have much of the instrumentation needed to gain the parametric information already installed. Today's instrumentation offers many cost-effective opportunities to gather information without having to incur the expense of running conduit with power and signal cabling. The information gatherers are generally already on the payroll and in many cases, already gathering the needed information to be trended. For the most part, establishing a trending program would require little more than using the information already gathered and currently collecting dust. Payback for the little extra money spent is quickly recovered in increased machine efficiency and decreased energy cost.

6.7.5 References/Resources

The resources provided below are by no means all-inclusive. To locate additional resources, the authors of this guide recommend contacting relevant trade groups, databases, and the world-wide web.

Although few Web sites provide specific information related to the performance trending methodology, several vendors do provide software to assist in data collection and analysis. A few of these vendors can be found at:

- <http://www.monarchinstrument.com/ontime.htm>.
- <http://www.rtx.com/TrendLink.htm>.

Chapter 7 O&M Ideas for Major Equipment Types

7.1 Introduction

At the heart of all O&M lies the equipment. Across the Federal sector, this equipment varies greatly in age, size, type, model, fuel used, condition, etc. While it is well beyond the scope of this guide to study all equipment types, we tried to focus our efforts on the more common types prevalent in the Federal sector. The objectives of this chapter are the following:

- Present general equipment descriptions and operating principles for the major equipment types.
- Discuss the key maintenance components of that equipment.
- Highlight important safety issues.
- Point out cost and efficiency issues.
- Provide recommended general O&M activities in the form of checklists.
- Where possible, provide case studies.

The checklists provided at the end of each section were compiled from a number of resources. These are not presented to replace activities specifically recommended by your equipment vendors or manufacturers. In most cases, these checklists represent industry standard best practices for the given equipment. They are presented here to supplement existing O&M procedures, or to merely serve as reminders of activities that should be taking place. The recommendations in this guide are designed to supplement those of the manufacturer, or, as is all too often the case, provide guidance for systems and equipment for which technical documentation has been lost. As a rule, this guide will first defer to the manufacturer's recommendations on equipment operations and maintenance.



Actions and activities recommended in this guide should only be attempted by trained and certified personnel. If such personnel are not available, the actions recommended here should not be initiated.



7.2 Boilers

7.2.1 Introduction

Boilers are fuel-burning appliances that produce either hot water or steam that gets circulated through piping for heating or process uses.

Boiler systems are major financial investments, yet the methods for protecting these investments vary widely. Proper maintenance and operation of boiler systems is important with regard to efficiency and reliability. Without this attention, boilers can be very dangerous (NBBPVI 2001b).

7.2.2 Types of Boilers (Niles and Rosaler 1998)

Boiler designs can be classified in three main divisions – fire-tube boiler, water-tube boiler, and electric boilers.

7.2.2.1 Fire-Tube Boilers

Fire-tube boilers rely on hot gases circulating through the boiler inside tubes that are submerged in water. These gases usually make several passes through these tubes, thereby transferring their heat through the tube walls causing the water to boil on the other side. Fire-tube boilers are generally available in the range 20 through 800 boiler horsepower (bhp) and in pressures up to 150 psi.

Boiler horsepower: As defined, 34.5 lb of steam at 212°F could do the same work (lifting weight) as one horse. In terms of Btu output - 1 bhp equals 33,475 Btu/hr.

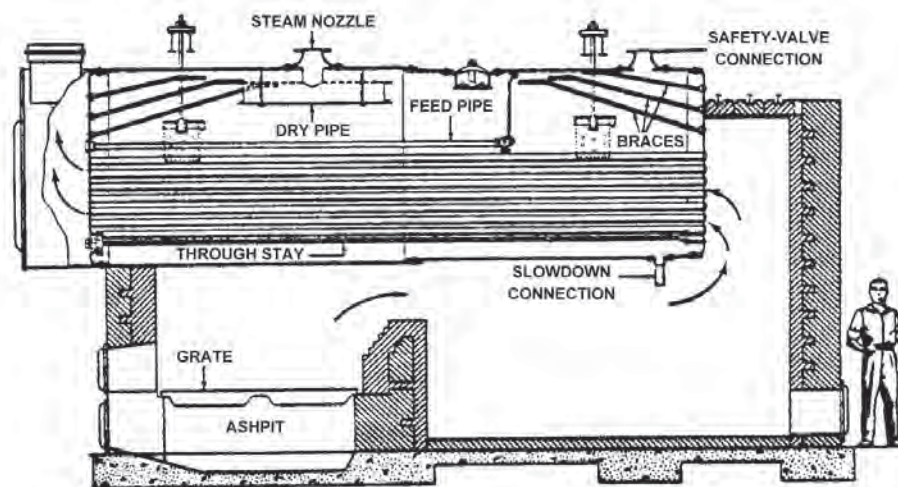

Reprinted with permission of
The Boiler Efficiency Institute,
Auburn, Alabama.

Figure 7.2.1. Horizontal return fire-tube boiler (hot gases pass through tube submerged in water).

7.2.2.2 Water-Tube Boilers

Most high-pressure and large boilers are of this type. It is important to note that the small tubes in the water-tube boiler can withstand high pressure better than the large vessels of a fire-tube boiler. In the water-tube boiler, gases flow over water-filled tubes. These water-filled tubes are in turn connected to large containers called drums.

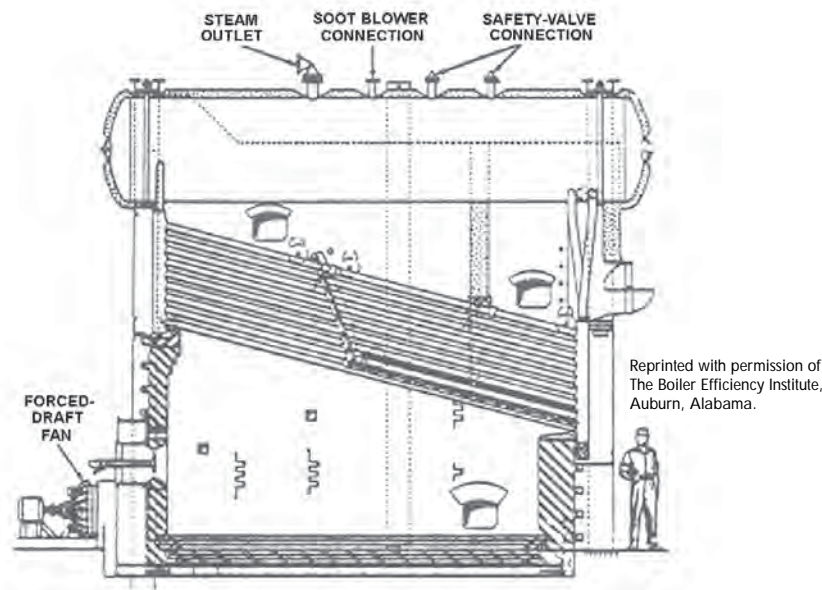

Figure 7.2.2. Longitudinal-drum water-tube boiler (water passes through tubes surrounded by hot gases).

Water-tube boilers are available in sizes ranging from smaller residential type to very large utility class boilers. Boiler pressures range from 15 psi through pressures exceeding 3,500 psi.

7.2.2.3 Electric Boilers

Electric boilers are very efficient sources of hot water or steam, which are available in ratings from 5 to over 50,000 kW. They can provide sufficient heat for any HVAC requirement in applications ranging from humidification to primary heat sources.

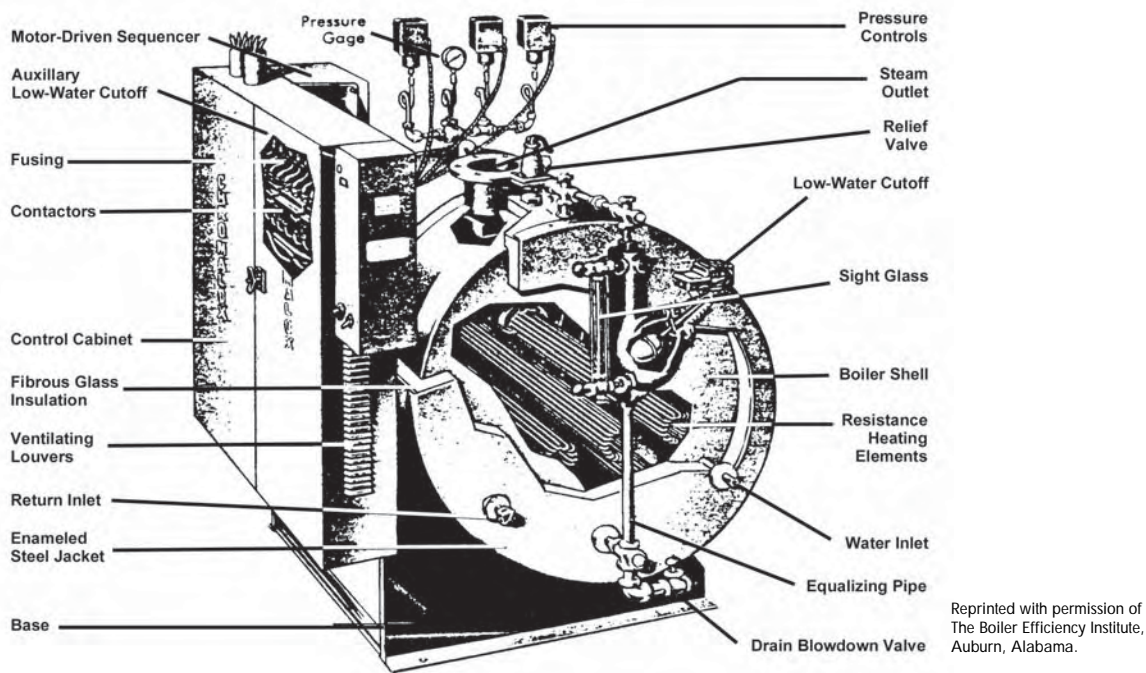

Figure 7.2.3. Electric boiler.

7.2.3 Key Components (Nakonezny 2001)

7.2.3.1 Critical Components

In general, the critical components are those whose failure will directly affect the reliability of the boiler. The critical components can be prioritized by the impact they have on safety, reliability, and performance. These critical pressure parts include:

- **Drums** – The steam drum is the single most expensive component in the boiler. Consequently, any maintenance program must address the steam drum, as well as any other drums, in the convection passes of the boiler. In general, problems in the drums are associated with corrosion. In some instances, where drums have rolled tubes, rolling may produce excessive stresses that can lead to damage in the ligament areas. Problems in the drums normally lead to indications that are seen on the surfaces—either inside diameter (ID) or outside diameter (OD).

Assessment: Inspection and testing focuses on detecting surface indications. The preferred nondestructive examination (NDE) method is wet fluorescent magnetic particle testing (WFMT). Because WFMT uses fluorescent particles that are examined under ultraviolet light, it is more sensitive than dry powder type magnetic particle testing (MT) and it is faster than liquid dye penetrant testing (PT) methods. WFMT should include the major welds, selected attachment welds, and at least some of the ligaments. If locations of corrosion are found, then ultrasonic thickness testing (UTT) may be performed to assess thinning due to metal loss. In rare instances, metallographic replication may be performed.

Reprinted with permission of The National Board of Boiler and Pressure Vessel Inspectors.

Most people do not realize the amount of energy that is contained within a boiler. Take for example, the following illustration by William Axtman: "If you could capture all the energy released when a 30-gallon home hot-water tank flashes into explosive failure at 332° F, you would have enough force to send the average car (weighing 2,500 pounds) to a height of nearly 125 feet. This is equivalent to more than the height of a 14-story apartment building, starting with a lift-off velocity of 85 miles per hour!" (NBBPVI 2001b)

- **Headers** – Boilers designed for temperatures above 900°F (482°C) can have superheater outlet headers that are subject to creep – the plastic deformation (strain) of the header from long-term exposure to temperature and stress. For high temperature headers, tests can include metallographic replication and ultrasonic angle beam shear wave inspections of higher stress weld locations. However, industrial boilers are more typically designed for temperatures less than 900°F (482°C) such that failure is not normally related to creep. Lower temperature headers are subject to corrosion or possible erosion. Additionally, cycles of thermal expansion and mechanical loading may lead to fatigue damage.

Assessment: NDE should include testing of the welds by MT or WFMT. In addition, it is advisable to perform internal inspection with a video probe to assess waterside cleanliness, to note any buildup of deposits or maintenance debris that could obstruct flow, and to determine if corrosion is a problem. Inspected headers should include some of the water circuit headers as well as superheater headers. If a location of corrosion is seen, then UTT to quantify remaining wall thickness is advisable.

- **Tubing** – By far, the greatest number of forced outages in all types of boilers are caused by tube failures. Failure mechanisms vary greatly from the long term to the short term. Superheater tubes

operating at sufficient temperature can fail long term (over many years) due to normal life expenditure. For these tubes with predicted finite life, Babcock & Wilcox (B&W) offers the NOTIS® test and remaining life analysis. However, most tubes in the industrial boiler do not have a finite life due to their temperature of operation under normal conditions. Tubes are more likely to fail because of abnormal deterioration such as water/steam-side deposition retarding heat transfer, flow obstructions, tube corrosion (ID and/or OD), fatigue, and tube erosion.

Assessment: Tubing is one of the components where visual examination is of great importance because many tube damage mechanisms lead to visual signs such as distortion, discoloration, swelling, or surface damage. The primary NDE method for obtaining data used in tube assessment is contact UTT for tube thickness measurements. Contact UTT is done on accessible tube surfaces by placing the UT transducer onto the tube using a couplant, a gel or fluid that transmits the UT sound into the tube. Variations on standard contact UTT have been developed due to access limitations. Examples are internal rotating inspection system (IRIS)-based techniques in which the UT signal is reflected from a high rpm rotating mirror to scan tubes from the ID—especially in the area adjacent to drums; and B&W’s immersion UT where a multiple transducer probe is inserted into boiler bank tubes from the steam drum to provide measurements at four orthogonal points. These systems can be advantageous in the assessment of pitting.

- **Piping**

- **Main Steam** – For lower temperature systems, the piping is subject to the same damage as noted for the boiler headers. In addition, the piping supports may experience deterioration and become damaged from excessive or cyclical system loads.

Assessment: The NDE method of choice for testing of external weld surfaces is WFMT. MT and PT are sometimes used if lighting or pipe geometry make WFMT impractical. Non-drainable sections, such as sagging horizontal runs, are subject to internal corrosion and pitting. These areas should be examined by internal video probe and/or UTT measurements. Volumetric inspection (i.e., ultrasonic shear wave) of selected piping welds may be included in the NDE; however, concerns for weld integrity associated with the growth of subsurface cracks is a problem associated with creep of high temperature piping and is not a concern on most industrial installations.

- **Feedwater** – A piping system often overlooked is feedwater piping. Depending upon the operating parameters of the feedwater system, the flow rates, and the piping geometry, the pipe may be prone to corrosion or flow assisted corrosion (FAC). This is also referred to as erosion-corrosion. If susceptible, the pipe may experience material loss from internal surfaces near bends, pumps, injection points, and flow transitions. Ingress of air into the system can lead to corrosion and pitting. Out-of-service corrosion can occur if the boiler is idle for long periods.

Assessment: Internal visual inspection with a video probe is recommended if access allows. NDE can include MT, PT, or WFMT at selected welds. UTT should be done in any location where FAC is suspected to ensure there is not significant piping wall loss.

- **Deaerators** – Overlooked for many years in condition assessment and maintenance inspection programs, deaerators have been known to fail catastrophically in both industrial and utility plants. The damage mechanism is corrosion of shell welds, which occurs on the ID surfaces.

Assessment: Deaerators’ welds should have a thorough visual inspection. All internal welds and selected external attachment welds should be tested by WFMT.

7.2.3.2 Other Components (Williamson-Thermoflo Company 2001)

- **Air openings**

Assessment: Verify that combustion and ventilation air openings to the boiler room and/or building are open and unobstructed. Check operation and wiring of automatic combustion air dampers, if used. Verify that boiler vent discharge and air intake are clean and free of obstructions.

- **Flue gas vent system**

Assessment: Visually inspect entire flue gas venting system for blockage, deterioration, or leakage. Repair any joints that show signs of leakage in accordance with vent manufacturer's instructions. Verify that masonry chimneys are lined, lining is in good condition, and there are not openings into the chimney.

- **Pilot and main burner flames**

Assessment: Visually inspect pilot burner and main burner flames.

- Proper pilot flame
 - Blue flame.
 - Inner cone engulfing thermocouple.
 - Thermocouple glowing cherry red.
- Improper pilot flame
 - Overfired – Large flame lifting or blowing past thermocouple.
 - Underfired – Small flame. Inner cone not engulfing thermocouple.
 - Lack of primary air – Yellow flame tip.
 - Incorrectly heated thermocouple.
- Check burner flames-Main burner
- Proper main burner flame

- **Yellow-orange streaks may appear (caused by dust)**

- Improper main burner flame
 - Overfired - Large flames.
 - Underfired - Small flames.
 - Lack of primary air - Yellow tipping on flames (sooting will occur).

- **Boiler heating surfaces**

Assessment: Use a bright light to inspect the boiler flue collector and heating surfaces. If the vent pipe or boiler interior surfaces show evidence of soot, clean boiler heating surfaces. Remove the flue collector and clean the boiler, if necessary, after closer inspection of boiler heating surfaces. If there is evidence of rusty scale deposits on boiler surfaces, check the water piping and control system to make sure the boiler return water temperature is properly maintained. Reconnect vent and draft diverter. Check inside and around boiler for evidence of any leaks from the boiler. If found, locate source of leaks and repair.

• **Burners and base**

Assessment: Inspect burners and all other components in the boiler base. If burners must be cleaned, raise rear of each burner to release from support slot, slide forward, and remove. Then brush and vacuum the burners thoroughly, making sure all ports are free of debris. Carefully replace all burners, making sure burner with pilot bracket is replaced in its original position and all burners are upright (ports up). Inspect the base insulation.

7.2.4 Safety Issues (NBBPVI 2001c)

At atmospheric pressure, 1 ft³ of water converted to steam expands to occupy 1,600 ft³ of space. If this expansion takes place in a vented tank, after which the vent is closed, the condensing steam will create a vacuum with an external force on the tank **of 900 tons!** Boiler operators must understand this concept (NTT 1996).

Boiler safety is a key objective of the National Board of Boiler and Pressure Vessel Inspectors. This organization tracks and reports on boiler safety and “incidents” related to boilers and pressure vessels that occur each year. The figure below details the 1999 boiler incidents by major category. It is important to note that the number one incident category resulting in injury was poor maintenance/operator error. Furthermore, statistics tracking loss-of-life incidents reported that in 1999, three of seven boiler-related deaths were attributed to poor maintenance/operator

error. The point of relaying this information is to suggest that through proper maintenance and operator training these incidents may be reduced.

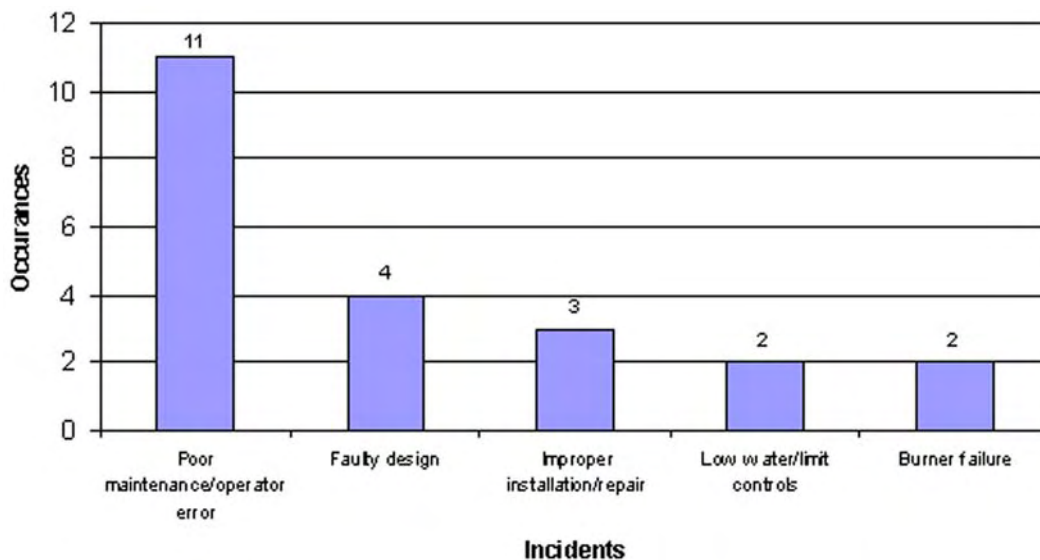

Figure 7.2.4. Adapted from 1999 National Board of Boiler and Pressure Vessel Inspectors incident report summary.

Boiler inspections should be performed at regular intervals by certified boiler inspectors. Inspections should include verification and function of all safety systems and procedures as well as operator certification review.

7.2.5 Cost and Energy Efficiency (Dyer and Maples 1988)

7.2.5.1 Efficiency, Safety, and Life of the Equipment

It is impossible to change the efficiency without changing the safety of the operation and the resultant life of the equipment, which in turn affects maintenance cost. An example to illustrate this relation between efficiency, safety, and life of the equipment is shown in the figure below. The temperature distribution in an efficient-operated boiler is shown as the solid line. If fouling develops on the waterside due to poor water quality control, it will result in a temperature increase of the hot gases on the fireside as shown by the dashed line. This fouling will result in an increase in stack temperature, thus decreasing the efficiency of the boiler. A metal failure will also change the life of the boiler, since fouling material will allow corrosion to occur, leading to increased maintenance cost and decreased equipment reliability and safety.

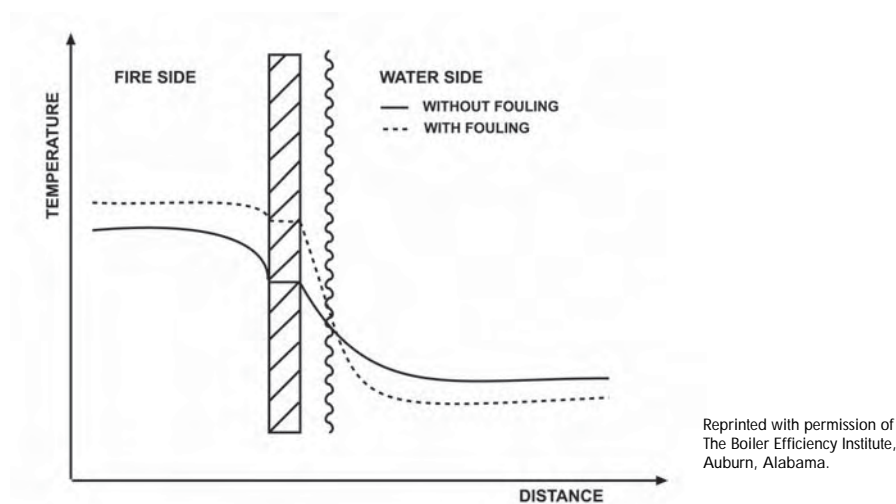

Figure 7.2.5. Effect of fouling on water side.

7.2.5.2 Results Best Practices

In a study conducted by the Boiler Efficiency Institute in Auburn, Alabama, researchers have developed eleven ways to improve boiler efficiency with important reasons behind each action.

- **Reduce excess air** – Excess air means there is more air for combustion than is required. The extra air is heated up and thrown away. The most important parameter affecting combustion efficiency is the air/fuel ratio.
 - **Symptom** – The oxygen in the air that is not used for combustion is discharged in the flue gas, therefore, a simple measurement of oxygen level in the exhaust gas tells us how much air is being used. **Note:** It is worth mentioning the other side of the spectrum. The so called “deficient air” must be avoided as well because (1) it decreases efficiency, (2) allows deposit of soot on the fire side, and (3) the flue gases are potentially explosive.
 - **Action Required** – Determine the combustion efficiency using dedicated or portable combustion analysis equipment. Adjustments for better burning
 - Cleaning
 - Swirl at burner inlet
 - New tips/orifices
 - Atomizing pressure

- Damper repair
- Control repair
- Refractory repair
- Fuel pressure
- Furnace pressure
- Fuel temperature
- Burner position
- Bed thickness
- Ratio under/overfire air
- Undergrate air distribution.

- **Install waste heat recovery** – The magnitude of the stack loss for boilers without recovery is about 18% on gas-fired and about 12% for oil- and coal-fired boilers. A major problem with heat recovery in flue gas is corrosion. If flue gas is cooled, drops of acid condense at the acid dew temperature. As the temperature of the flue gas is dropped further, the water dew point is reached at which water condenses. The water mixes with the acid and reduces the severity of the corrosion problem.

- **Symptom** – Flue gas temperature is the indicator that determines whether an economizer or air heater is needed. It must be remembered that many factors cause high flue gas temperature (i.e., fouled waterside or fireside surfaces, excess air, etc.).
- **Action Required** - If flue gas temperature exceeds minimum allowable temperature by 50°F or more, a conventional economizer may be economically feasible. An unconventional recovery device should be considered if the low-temperature waste heat saved can be utilized in heating water or air. **Cautionary Note:** *A high flue gas temperature may be a sign of poor heat transfer resulting from scale or soot deposits. Boilers should be cleaned and tuned before considering the installation of a waste heat recovery system.*

- **Reduce scale and soot deposits** – Scale or deposits serve as an insulator, resulting in more heat from the flame going up the stack rather than to the water due to these deposits. Any scale formation has a tremendous potential to decrease the heat transfer.

Scale deposits on the water side and soot deposits on the fire side of a boiler not only act as insulators that reduce efficiency, but also cause damage to the tube structure due to overheating and corrosion.

- **Symptom** – The best indirect indicator for scale or deposit build-up is the flue gas temperature. If at the same load and excess air the flue gas temperature rises with time, the effect is probably due to scale or deposits.
- **Action Required** – Soot is caused primarily by incomplete combustion. This is probably due to deficient air, a fouled burner, a defective burner, etc. Adjust excess air. Make repairs as necessary to eliminate smoke and carbon monoxide.

Scale formation is due to poor water quality. First, the water must be soft as it enters the boiler. Sufficient chemical must be fed in the boiler to control hardness.

- **Reduce blowdown** – Blowdown results in the energy in the hot water being lost to the sewer unless energy recovery equipment is used. There are two types of blowdowns. Mud blow is designed to remove the heavy sludge that accumulates at the bottom of the boiler. Continuous or skimming blow is designed to remove light solids that are dissolved in the water.

- **Symptom** – Observe the closeness of the various water quality parameters to the tolerances stipulated for the boiler per manufacturer specifications and check a sample of mud blowdown to ensure blowdown is only used for that purpose. Check the water quality in the boiler using standards chemical tests.

- *Action Required* – Conduct proper pre-treatment of the water by ensuring makeup is softened. Perform a “mud test” each time a mud blowdown is executed to reduce it to a minimum. A test should be conducted to see how high total dissolved solids (TDS) in the boiler can be carried without carryover.
- **Recover waste heat from blowdown** – Blowdown contains energy, which can be captured by a waste heat recovery system.
 - *Symptom and Action Required* – Any boiler with a significant makeup (say 5%) is a candidate for blowdown waste heat recovery.
- **Stop dynamic operation on applicable boilers**
 - *Symptom* – Any boiler which either stays off a significant amount of time or continuously varies in firing rate can be changed to improve efficiency.
 - *Action Required* – For boilers which operate on and off, it may be possible to reduce the firing rate by changing burner tips. Another point to consider is whether more boilers are being used than necessary.
- **Reduce line pressure** – Line pressure sets the steam temperature for saturated steam.
 - *Symptom and Action Required* – Any steam line that is being operated at a pressure higher than the process requirements offers a potential to save energy by reducing steam line pressure to a minimum required pressure determined by engineering studies of the systems for different seasons of the year.
- **Cogenerate** – This refers to correct utilization of steam pressure. A boiler provides steam to a turbine, which in turn, is coupled to an electric generator. In this process, all steam exhaust from the turbine must be fully utilized in a process requirement.
- **Operate boilers at peak efficiency** – Plants having two or more boilers can save energy by load management such that each boiler is operated to obtain combined peak efficiency.
 - *Symptom and Action Required* – Improved efficiency can be obtained by proper load selection, if operators determine firing schedule by those boilers, which operate “smoothly.”
- **Preheat combustion air** – Since the boiler and stack release heat, which rises to the top of the boiler room, the air ducts can be arranged so the boiler is able to draw the hot air down back to the boiler.
 - *Symptom* – Measure vertical temperature in the boiler room to indicate magnitude of stratification of the air.
 - *Action Required* – Modify the air circulation so the boiler intake for outside air is able to draw from the top of the boiler room.
- **Switch from steam to air atomization** – The energy to produce the air is a tiny fraction of the energy in the fuel, while the energy in the steam is usually 1% or more of the energy in the fuel.
 - *Symptom* – Any steam-atomized burner is a candidate for retrofit.
 - *Action Required* – Check economics to see if satisfactory return on investment is available.

Typical uses for waste heat include:

- Heating of combustion air
- Makeup water heating
- Boiler feedwater heating
- Appropriate process water heating
- Domestic water heating.

Reprinted with permission of the National Board of Boiler and Pressure Vessel Inspectors.

General Requirements for a Safe and Efficient Boiler Room

1. Keep the boiler room clean and clear of all unnecessary items. The boiler room should not be considered an all-purpose storage area. The burner requires proper air circulation in order to prevent incomplete fuel combustion. Use boiler operating log sheets, maintenance records, and the production of carbon monoxide. The boiler room is for the boiler!
2. Ensure that all personnel who operate or maintain the boiler room are properly trained on all equipment, controls, safety devices, and up-to-date operating procedures.
3. Before start-up, ensure that the boiler room is free of all potentially dangerous situations, like flammable materials, mechanical, or physical damage to the boiler or related equipment. Clear intakes and exhaust vents; check for deterioration and possible leaks.
4. Ensure a thorough inspection by a properly qualified inspector.
5. After any extensive repair or new installation of equipment, make sure a qualified boiler inspector re-inspects the entire system.
6. Monitor all new equipment closely until safety and efficiency are demonstrated.
7. Use boiler operating log sheets, maintenance records, and manufacturer's recommendations to establish a preventive maintenance schedule based on operating conditions, past maintenance, repair, and replacement that were performed on the equipment.
8. Establish a checklist for proper startup and shutdown of boilers and all related equipment according to manufacturer's recommendations.
9. Observe equipment extensively before allowing an automating operation system to be used with minimal supervision.
10. Establish a periodic preventive maintenance and safety program that follows manufacturer's recommendations.

7.2.6 Maintenance of Boilers (NBBPVI 2001a)

A boiler efficiency improvement program must include two aspects: (1) action to bring the boiler to peak efficiency and (2) action to maintain the efficiency at the maximum level. Good maintenance and efficiency start with having a working knowledge of the components associated with the boiler, keeping records, etc., and end with cleaning heat transfer surfaces, adjusting the air-to-fuel ratio, etc.

7.2.7 Diagnostic Tools

- **Combustion analyzer** – A combustion analyzer samples, analyzes, and reports the combustion efficiency of most types of combustion equipment including boilers, furnaces, and water heaters. When properly maintained and calibrated, these devices provide an accurate measure of combustion efficiency from which efficiency corrections can be made. Combustion analyzers come in a variety of styles from portable units to dedicated units.
- **Thermography** – An infrared thermometer or camera allows for an accurate, non-contact assessment of temperature. Applications for boilers include insulation assessments on boilers, steam,

and condensate-return piping. Other applications include motor/bearing temperature assessments on feedwater pumps and draft fan systems. More information on thermography can be found in Chapter 6.

7.2.8 Case Studies (NBBPVI 2001a)

Boiler Maintenance and its Impact

A 300-hp boiler installed at a public school in Canada was valued at about \$100,000. After a maintenance worker noticed water dripping from a steam valve, the boiler was shut down for inspection. During the inspection, insulation was removed. The boiler inspector concluded that water had been leaking into the insulation for so long that corrosion had developed completely around the boiler. The inspector could actually penetrate the boiler with a pocketknife. The boiler was a total loss-yet less than \$5 worth of packing for the valve, applied at the right time, would have saved the boiler.

Lesson Learned: Operators and maintenance technicians must conduct a visual inspection of a boiler, especially during start-ups and running operations. Maintenance personnel must follow and perform all maintenance requirements, to the letter, per manufacturer requirements. Operators must report any anomalies as soon as possible, so they can be taken care of before the problem grows beyond repair.

Combustion Efficiency of a Natural Gas Boiler (OIT 1995)

A study of combustion efficiency of a 300 hp natural-gas-fired heating boiler was completed. Flue gas measurements were taken and found a temperature of 400°F and a percentage of oxygen of 6.2%. An efficient, well-tuned boiler of this type and size should have a percent oxygen reading of about 2% – corresponding to about 10% excess air. This extra oxygen in the flue gas translates into excess air (and its heat) traveling out of the boiler system – a waste of energy.

The calculated savings from bringing this boiler to the recommended oxygen/excess air level was about \$730 per year. The cost to implement this action included the purchase of an inexpensive combustion analyzer costing \$500. Thus, the cost savings of \$730 would pay for the implementation cost of \$500 in about 8 months. Added to these savings is the ability to tune other boilers at the site with this same analyzer.

7.2.9 Boilers Checklist

Description	Comments	Maintenance Frequency															
		Daily	Weekly	Monthly	Annually												
Boiler use/sequencing	Turn off/sequence unnecessary boilers	X															
Overall visual inspection	Complete overall visual inspection to be sure all equipment is operating and safety systems are in place	X															
Follow manufacturer's recommended procedures in lubricating all components	Compare temperatures with tests performed after annual cleaning	X															
Check steam pressure	Is variation in steam pressure as expected under different loads? Wet steam may be produced if the pressure drops too fast	X															
Check unstable water level	Unstable levels can be a sign of contaminants in feedwater, overloading of boiler, equipment malfunction	X															
Check burner	Check for proper control and cleanliness	X															
Check motor condition temperatures	Check for proper function	X															
Check air temperatures in boiler room	Temperatures should not exceed or drop below design limits	X															
Boiler blowdown	Verify the bottom, surface and water column blow downs are occurring and are effective	X															
Boiler logs	Keep daily logs on: <ul style="list-style-type: none"> • Type and amount of fuel used • Flue gas temperature • Makeup water volume • Steam pressure, temperature, and amount generated Look for variations as a method of fault detection	X															
Check oil filter assemblies	Check and clean/replace oil filters and strainers	X															
Inspect oil heaters	Check to ensure that oil is at proper temperature prior to burning	X															
Check boiler water treatment	Confirm water treatment system is functioning properly	X															
Check flue gas temperatures and composition	Measure flue gas composition and temperatures at selected firing positions - recommended O ₂ % and CO ₂ % <table style="margin-left: 20px; border-collapse: collapse;"> <tr> <td style="padding-right: 20px;">Fuel</td> <td style="padding-right: 20px;">O₂ %</td> <td>CO₂%</td> </tr> <tr> <td>Natural gas</td> <td>1.5</td> <td>10</td> </tr> <tr> <td>No. 2 fuel oil</td> <td>2.0</td> <td>11.5</td> </tr> <tr> <td>No. 6 fuel oil</td> <td>2.5</td> <td>12.5</td> </tr> </table> Note: percentages may vary due to fuel composition variations	Fuel	O ₂ %	CO ₂ %	Natural gas	1.5	10	No. 2 fuel oil	2.0	11.5	No. 6 fuel oil	2.5	12.5				X
Fuel	O ₂ %	CO ₂ %															
Natural gas	1.5	10															
No. 2 fuel oil	2.0	11.5															
No. 6 fuel oil	2.5	12.5															

Boilers Checklist (contd)

Description	Comments	Maintenance Frequency			
		Daily	Weekly	Monthly	Annually
Check all relief valves	Check for leaks		X		
Check water level control	Stop feedwater pump and allow control to stop fuel flow to burner. Do not allow water level to drop below recommended level.		X		
Check pilot and burner assemblies	Clean pilot and burner following manufacturer's guidelines. Examine for mineral or corrosion buildup.		X		
Check boiler operating characteristics	Stop fuel flow and observe flame failure. Start boiler and observe characteristics of flame.		X		
Inspect system for water/steam leaks and leakage opportunities	Look for: leaks, defective valves and traps, corroded piping, condition of insulation		X		
Inspect all linkages on combustion air dampers and fuel valves	Check for proper setting and tightness		X		
Inspect boiler for air leaks	Check damper seals		X		
Check blowdown and water treatment procedures	Determine if blowdown is adequate to prevent solids buildup			X	
Flue gases	Measure and compare last month's readings flue gas composition over entire firing range			X	
Combustion air supply	Check combustion air inlet to boiler room and boiler to make sure openings are adequate and clean			X	
Check fuel system	Check pressure gauge, pumps, filters and transfer lines. Clean filters as required.			X	
Check belts and packing glands	Check belts for proper tension. Check packing glands for compression leakage.			X	
Check for air leaks	Check for air leaks around access openings and flame scanner assembly.			X	
Check all blower belts	Check for tightness and minimum slippage.			X	
Check all gaskets	Check gaskets for tight sealing, replace if do not provide tight seal			X	
Inspect boiler insulation	Inspect all boiler insulation and casings for hot spots			X	
Steam control valves	Calibrate steam control valves as specified by manufacturer			X	
Pressure reducing/regulating valves	Check for proper operation			X	

Boilers Checklist (contd)

Description	Comments	Maintenance Frequency			
		Daily	Weekly	Monthly	Annually
Perform water quality test	Check water quality for proper chemical balance			X	
Clean waterside surfaces	Follow manufacturer's recommendation on cleaning and preparing waterside surfaces				X
Clean fireside	Follow manufacturer's recommendation on cleaning and preparing fireside surfaces				X
Inspect and repair refractories on fireside	Use recommended material and procedures				X
Relief valve	Remove and recondition or replace				X
Feedwater system	Clean and recondition feedwater pumps. Clean condensate receivers and deaeration system				X
Fuel system	Clean and recondition system pumps, filters, pilot, oil preheaters, oil storage tanks, etc.				X
Electrical systems	Clean all electrical terminals. Check electronic controls and replace any defective parts.				X
Hydraulic and pneumatic valves	Check operation and repair as necessary				X
Flue gases	Make adjustments to give optimal flue gas composition. Record composition, firing position, and temperature.				X
Eddy current test	As required, conduct eddy current test to assess tube wall thickness				X

7.2.10 References

Dyer D.F. and G. Maples. 1988. *Boiler Efficiency Improvement*. Boiler Efficiency Institute, Auburn, Alabama.

Nakoneczny G.J. July 1, 2001. *Boiler Fitness Survey for Condition Assessment of Industrial Boilers*, BR-1635, Babcock & Wilcox Company [Online report]. Available URL: <http://www.babcock.com/pgg/tt/pdf/BR-1635.pdf>.

Niles R.G. and R.C. Rosaler. 1998. *HVAC Systems and Components Handbook*. 2nd ed. McGraw-Hill, New York.

OIT. 1995. *Modern Industrial Assessments: A Training Manual*. Industrial Assessment Manual from the Office of Productivity and Energy Assessment at the State University of New Jersey, Rutgers, for the U.S. Department of Energy Office of Industrial Technology.

The National Board of Boiler and Pressure Vessel Inspectors (NBBPVI). April 15, 2001a. *School Boiler Maintenance Programs: How Safe are The Children*. National Board BULLETIN, Fall 1997 [On-line report]. Available URL: <http://www.nationalboard.org/Publications/Bulletin/FA97.pdf>.

The National Board of Boiler and Pressure Vessel Inspectors (NBBPVI). April 15, 2001b. *Is preventive maintenance cost effective?* National Board BULLETIN, Summer 2000 [Online report]. Available URL: <http://www.nationalboard.org/Publications/Bulletin/SU00.pdf>.

The National Board of Boiler and Pressure Vessel Inspectors (NBBPVI). April 15, 2001c. *1999 Incident Report*. National Board BULLETIN, Summer 2000 [Online report]. Available URL: <http://www.nationalboard.org/Publications/Bulletin/SU00.pdf>.

NTT. 1996. *Boilers: An Operators Workshop*. National Technology Transfer, Inc. Englewood, Colorado.

Williamson-Thermoflo Company. July 12, 2001. *GSA Gas Fired Steam Boilers: Boiler Manual*. Part Number 550-110-738/0600, Williamson-Thermoflo [Online report]. Available URL: http://www.williamson-thermoflo.com/pdf_files/550-110-738.pdf.

7.3 Steam Traps

7.3.1 Introduction

Steam traps are automatic valves that release condensed steam (condensate) from a steam space while preventing the loss of live steam. They also remove non-condensable gases from the steam space. Steam traps are designed to maintain steam energy efficiency for performing specific tasks such as heating a building or maintaining heat for process. Once steam has transferred heat through a process and becomes hot water, it is removed by the trap from the steam side as condensate and either returned to the boiler via condensate return lines or discharged to the atmosphere, which is a wasteful practice (Gorelik and Bandes 2001).

7.3.2 Types of Steam Traps (DOE 2001a)

Steam traps are commonly classified by the physical process causing them to open and close. The three major categories of steam traps are 1) mechanical, 2) thermostatic, and 3) thermodynamic. In addition, some steam traps combine characteristics of more than one of these basic categories.

7.3.2.1 Mechanical Steam Trap

The operation of a mechanical steam trap is driven by the difference in density between condensate and steam. The denser condensate rests on the bottom of any vessel containing the two fluids. As additional condensate is generated, its level in the vessel will rise. This action is transmitted to a valve via either a “free float” or a float and connecting levers in a mechanical steam trap. One common type of mechanical steam trap is the inverted bucket trap shown in Figure 7.3.1. Steam entering the submerged bucket causes it to rise upward and seal the valve against the valve seat. As the steam condenses inside the bucket or if condensate is predominately entering the bucket, the weight of the bucket will cause it to sink and pull the valve away from the valve seat. Any air or other non-condensable gases entering the bucket will cause it to float and the valve to close. Thus, the top of the bucket has a small hole to allow non-condensable gases to escape. The hole must be relatively small to avoid excessive steam loss.

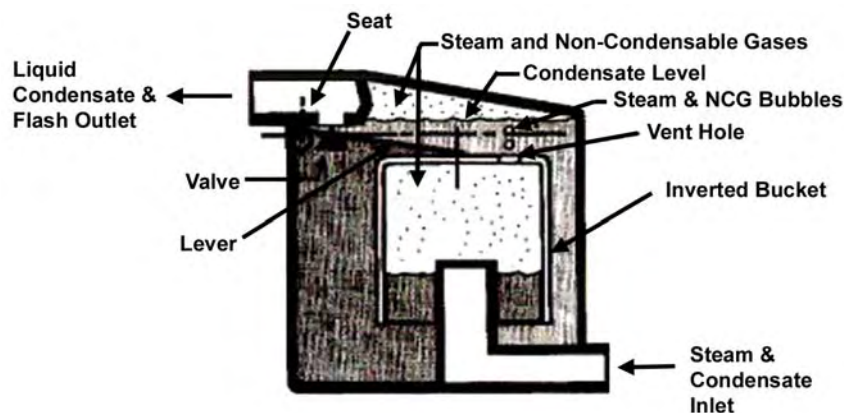

Figure 7.3.1. Inverted bucket steam trap.

7.3.2.2 Thermostatic Steam Trap

As the name implies, the operation of a thermostatic steam trap is driven by the difference in temperature between steam and sub-cooled condensate. Valve actuation is achieved via expansion and contraction of a bimetallic element or a liquid-filled bellows. Bimetallic and bellows thermostatic traps are shown in Figures 7.3.2 and 7.3.3. Although both types of thermostatic traps close when exposure to steam expands the bimetallic element or bellows, there are important differences in design and operating characteristics. Upstream pressure works to open the valve in a bimetallic trap, while expansion of the bimetallic element works in the opposite direction. Note that changes in the downstream pressure will affect the temperature at which the valve opens or closes. In addition, the nonlinear relationship between steam pressure and temperature requires careful design of the bimetallic element for proper response at different operating pressures. Upstream and downstream pressures have the opposite affect in a bellows trap; an increase in upstream pressure tends to close the valve and vice versa. While higher temperatures still work to close the valve, the relationship between temperature and bellows expansion can be made to vary significantly by changing the fluid inside the bellows. Using water within the bellows results in nearly identical expansion as steam temperature and pressure increase, because pressure inside and outside the bellows is nearly balanced.

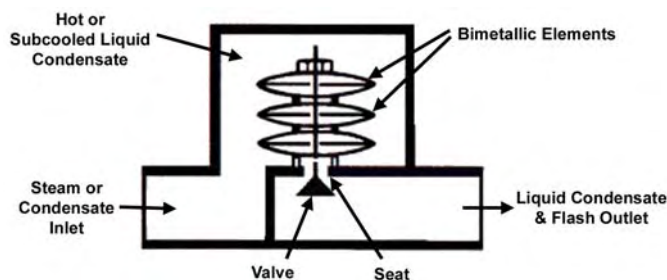

Figure 7.3.2. Bimetallic steam trap.

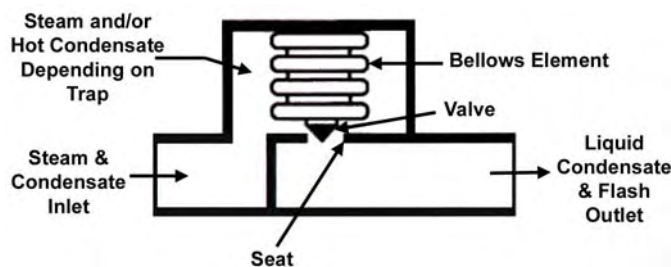

Figure 7.3.3. Bellows steam trap.

In contrast to the inverted bucket trap, both types of thermostatic traps allow rapid purging of air at startup. The inverted bucket trap relies on fluid density differences to actuate its valve. Therefore, it cannot distinguish between air and steam and must purge air (and some steam) through a small hole. A thermostatic trap, on the other hand, relies on temperature differences to actuate its valve. Until warmed by steam, its valve will remain wide open, allowing the air to easily leave. After the trap warms up, its valve will close, and no continuous loss of steam through a purge hole occurs. Recognition of this deficiency with inverted bucket traps or other simple mechanical traps led to the development of float and thermostatic traps. The condensate release valve is driven by the level of condensate inside the trap, while an air release valve is driven by the temperature of the trap. A float and thermostatic trap, shown in Figure 7.3.4, has a float that controls the condensate valve and a

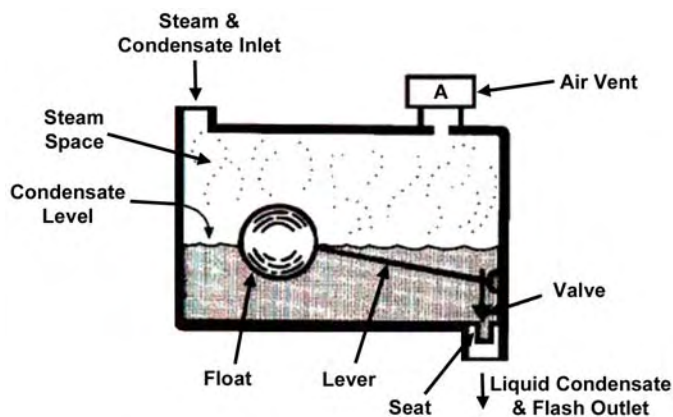

Figure 7.3.4. Float and thermostatic steam trap.

thermostatic element. When condensate enters the trap, the float raises allowing condensate to exit. The thermostatic element opens only if there is a temperature drop around the element caused by air or other non-condensable gases.

7.3.2.3 Thermodynamic Steam Traps

Thermodynamic trap valves are driven by differences in the pressure applied by steam and condensate, with the presence of steam or condensate within the trap being affected by the design of the trap and its impact on local flow velocity and pressure. Disc, piston, and lever designs are three types of thermodynamic traps with similar operating principles; a disc trap is shown in Figure 7.3.5. When sub-cooled condensate enters the trap, the increase in pressure lifts the disc off its valve seat and allows the condensate to flow into the chamber and out of the trap. The narrow inlet port results in a localized increase in velocity and decrease in pressure as the condensate flows through the trap, following the first law of thermodynamics and the Bernoulli equation. As the condensate entering the trap increases in temperature, it will eventually flash to steam because of the localized pressure drop just described. This increases the velocity and decreases the pressure even further, causing the disc to snap close against the seating surface. The moderate pressure of the flash steam on top of the disc acts on the entire disc surface, creating a greater force than the higher pressure steam and condensate at the inlet, which acts on a much smaller portion on the opposite side of the disc. Eventually, the disc chamber will cool, the flash steam will condense, and inlet condensate will again have adequate pressure to lift the disc and repeat the cycle.

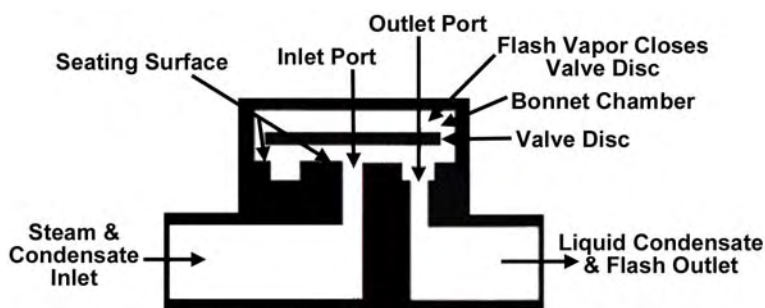

Figure 7.3.5. Disc steam trap.

7.3.2.4 Other Steam Traps

Another type of steam trap is the fixed orifice steam trap. Fixed orifice traps contain a set orifice in the trap body and continually discharge condensate. They are said to be self-regulating. As the rate of condensation decreases, the condensate temperature will increase, causing a throttling in the orifice and reducing capacity due to steam flashing on the downstream side. An increased load will decrease flashing and the orifice capacity will become greater (Gorelik and Bandes 2001). Orifice steam traps function best in situations with relatively constant steam loads. In situations where steam loads vary, the orifice trap either is allowing steam to escape or condensate to back up into the system. Varying loads, such as those found in most steam heating systems, are usually not good candidates for orifice steam traps. Before an orifice trap is specified, a careful analysis of appropriateness is recommended—preferably done by someone not selling orifice steam traps!

7.3.3 Safety Issues

When steam traps cause a backup of condensate in a steam main, the condensate is carried along with the steam. It lowers steam quality and increases the potential for water hammer. Not only will energy be wasted, equipment can be destroyed. Water hammer occurs as slugs of water are picked up at high speeds in a poorly designed steam main, in pipe coils, or where there is a lift after a steam trap. In some systems, the flow may be at 120 feet per second, which is about 82 mph. As the slug of condensate is carried along the steam line, it reaches an obstruction, such as a bend or a valve, where it is suddenly stopped. The effect of this impact can be imagined. It is important to note that the damaging effect of water hammer is due to steam velocity, not steam pressure. It can be as damaging in low-pressure systems as it can in high. This can actually produce a safety hazard, as the force of water hammer can blow out a valve or a strainer. Condensate in a steam system can be very destructive. It can cause valves to become wiredrawn and unable to hold temperatures as required. Little beads of water in a steam line can eventually cut any small orifices the steam normally passes through. Wire-drawing will eventually cut enough of the metal in a valve seat that it prevents adequate closure, producing leakage in the system (Gorelik and Bandes 2001).

7.3.4 Cost and Energy Efficiency (DOE 2001a)

Monitoring and evaluation equipment does not save any energy directly, but identifies traps that have failed and whether failure has occurred in an open or closed position. Traps failing in an open position allow steam to pass continuously, as long as the system is energized. The rate of energy loss can be estimated based on the size of the orifice and system steam pressure using the relationship illustrated in Figure 7.3.6. This figure is derived from Grashof's equation for steam discharge through an orifice (Avallone and Baumeister 1986) and assumes the trap is energized (leaks) the entire year, all steam leak energy is lost, and that makeup water is available at an average temperature of 60°F. Boiler losses are not included in Figure 7.3.6, so must be accounted for separately. Thus, adjustments from the raw estimate read from this figure must be made to account for less than full-time steam supply and for boiler losses.

The maximum steam loss rate occurs when a trap fails with its valve stuck in a fully opened position. While this failure mode is relatively common, the actual orifice size could be any fraction of the fully opened position. Therefore, judgment must be applied to estimate the orifice size associated with a specific malfunctioning trap. Lacking better data, assuming a trap has failed with an orifice size equivalent to one-half of its fully-opened condition is probably prudent.

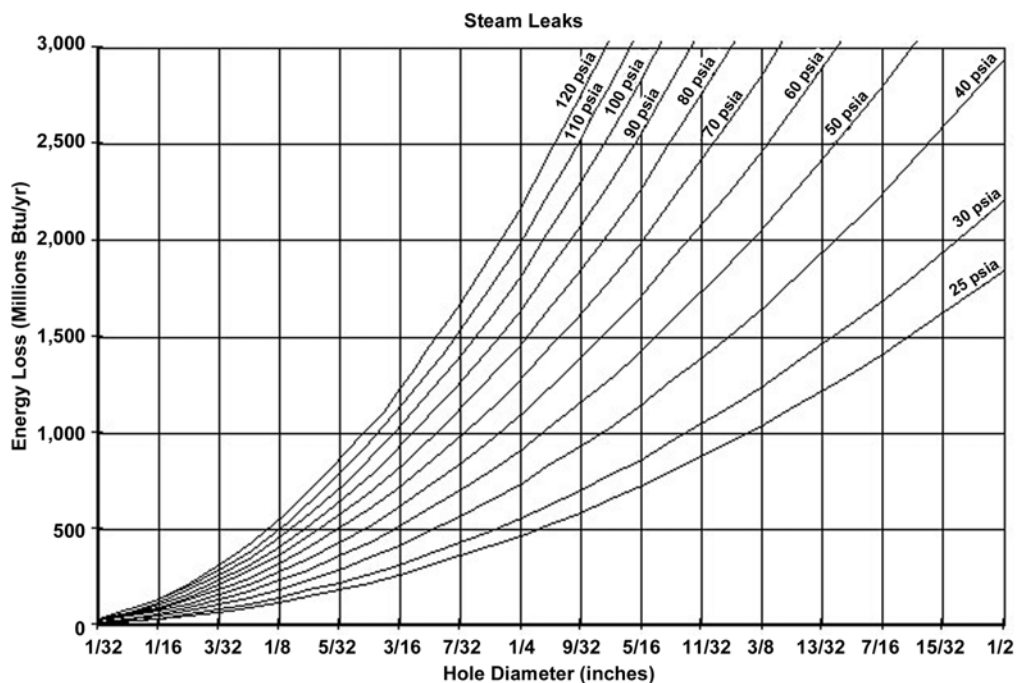

Figure 7.3.6. Energy loss from leaking steam traps.

7.3.4.1 Other Costs

Where condensate is not returned to the boiler, water losses will be proportional to the energy losses noted above. Feed-water treatment costs (i.e., chemical to treat makeup water) will also be proportionately increased. In turn, an increase in make-up water increases the blow-down requirement and associated energy and water losses. Even where condensate is returned to the boiler, steam bypassing a trap may not condense prior to arriving at the deaerator, where it may be vented along with the non-condensable gases. Steam losses also represent a loss in steam-heating capacity, which

The use of Figure 7.3.6 is illustrated via the following example. Inspection and observation of a trap led to the judgment that it had failed in the fully open position and was blowing steam. Manufacturer data indicated that the actual orifice diameter was 3/8 inch. The trap operated at 60 psia and was energized for 50% of the year. Boiler efficiency was estimated to be 75%. Calculation of annual energy loss for this example is illustrated below.

Estimating steam loss using Figure 7.3.6.

Assume: 3/8-inch diameter orifice steam trap, 50% blocked, 60psia saturated steam system, steam system energized 4,380 h/yr (50% of year), 75% boiler efficiency.

- Using Figure 7.3.6 for 3/8-inch orifice and 60 psia steam, steam loss = 2,500 million Btu/yr.
- Assuming trap is 50% blocked, annual steam loss estimate = 1,250 million Btu/yr.
- Assuming steam system is energized 50% of the year, energy loss = 625 million Btu/yr.
- Assuming a fuel value of \$5.00 per million cubic feet (1 million Btu boiler input).

Annual fuel loss including boiler losses = [(625 million Btu/yr) / (75% efficiency) (\$5.00/million Btu)] = \$4,165/yr.

could result in an inability to maintain the indoor design temperature on winter days or reduce production capacity in process heating applications. Traps that fail closed do not result in energy or water losses, but can also result in significant capacity reduction (as the condensate takes up pipe cross-sectional area that otherwise would be available for steam flow). Of generally more critical concern is the physical damage that can result from the irregular movement of condensate in a two-phase system, a problem commonly referred to as “water hammer.”

7.3.5 Maintenance of Steam Traps

Considering that many Federal sites have hundreds if not thousands of traps, and that one malfunctioning steam trap can cost thousands of dollars in wasted steam per year, steam trap maintenance should receive a constant and dedicated effort.

Excluding design problems, two of the most common causes of trap failure are oversizing and dirt.

- Oversizing causes traps to work too hard. In some cases, this can result in blowing of live steam. As an example, an inverted bucket trap can lose its prime due to an abrupt change in pressure. This will cause the bucket to sink, forcing the valve open.
- Dirt is always being created in a steam system. Excessive build-up can cause plugging or prevent a valve from closing. Dirt is generally produced from pipe scale or from over-treating of chemicals in a boiler.

7.3.5.1 Characteristics of Steam Trap Failure (Gorelik and Bandes 2001)

- Mechanical Steam Trap (Inverted Bucket Steam Trap) – Inverted bucket traps have a “bucket” that rises or falls as steam and/or condensate enters the trap body. When steam is in the body, the bucket rises closing a valve. As condensate enters, the bucket sinks down, opening a valve and allowing the condensate to drain. Inverted bucket traps are ideally suited for water-hammer conditions but may be subject to freezing in low temperature climates if not insulated. Usually, when this trap fails, it fails open. Either the bucket loses its prime and sinks or impurities in the system may prevent the valve from closing.

Checklist Indicating Possible Steam Trap Failure

- Abnormally warm boiler room.
- Condensate received venting steam.
- Condensate pump water seal failing prematurely.
- Overheating or underheating in conditioned space.
- Boiler operating pressure difficult to maintain.
- Vacuum in return lines difficult to maintain.
- Water hammer in steam lines.
- Steam in condensate return lines.
- Higher than normal energy bill.
- Inlet and outlet lines to trap nearly the same temperature.

- Thermostatic Steam Trap (Bimetallic and Bellows Steam Traps) – Thermostatic traps have, as the main operating element, a metallic corrugated bellows that is filled with an alcohol mixture that has a boiling point lower than that of water. The bellows will contract when in contact with condensate and expand when steam is present. Should a heavy condensate load occur, such as in start-up, the bellows will remain in a contracted state, allowing condensate to flow continuously. As steam builds up, the bellows will close. Therefore, there will be moments when this trap will act as a “continuous flow” type while at other times, it will act intermittently as it opens and closes to condensate and steam, or it may remain totally closed. These traps adjust automatically

to variations of steam pressure but may be damaged in the presence of water hammer. They can fail open should the bellows become damaged or due to particulates in the valve hole, preventing adequate closing. There can be times when the tray becomes plugged and will fail closed.

- **Thermodynamic Steam Trap (Disc Steam Trap)** – Thermodynamic traps have a disc that rises and falls depending on the variations in pressure between steam and condensate. Steam will tend to keep the disc down or closed. As condensate builds up, it reduces the pressure in the upper chamber and allows the disc to move up for condensate discharge. This trap is a good general type trap where steam pressures remain constant. It can handle superheat and “water hammer” but is not recommended for process, since it has a tendency to air-bind and does not handle pressure fluctuations well. A thermodynamic trap usually fails open. There are other conditions that may indicate steam wastage, such as “motor boating,” in which the disc begins to wear and fluctuates rapidly, allowing steam to leak through.
- **Other Steam Traps (Thermostatic and Float Steam Trap and Orifice Steam Trap)** – Float and thermostatic traps consist of a ball float and a thermostatic bellows element. As condensate flows through the body, the float rises or falls, opening the valve according to the flow rate. The thermostatic element discharges air from the steam lines. They are good in heavy and light loads and on high and low pressure, but are not recommended where water hammer is a possibility. When these traps fail, they usually fail closed. However, the ball float may become damaged and sink down, failing in the open position. The thermostatic element may also fail and cause a “fail open” condition.

General Requirements for Safe and Efficient Operation of Steam Traps (Climate Technology Initiative 2001)

1. Every operating area should have a program to routinely check steam traps for proper operation. Testing frequency depends on local experiences but should at least occur yearly.
2. All traps should be numbered and locations mapped for easier testing and record-keeping. Trap supply and return lines should be noted to simplify isolation and repair.
3. Maintenance and operational personnel should be adequately trained in trap testing techniques. Where ultrasonic testing is needed, specially trained personnel should be used.
4. High maintenance priority should be given to the repair or maintenance of failed traps. Attention to such a timely maintenance procedure can reduce failures to 3% to 5% or less. A failed open trap can mean steam losses of 50 to 100 lb/hr.
5. All traps in closed systems should have atmospheric vents so that trap operation can be visually checked. If trap headers are not equipped with these, they should be modified.
6. Proper trap design should be selected for each specific application. Inverted bucket traps may be preferred over thermostatic and thermodynamic-type traps for certain applications.
7. It is important to be able to observe the discharge from traps through the header. Although several different techniques can be used, the most foolproof method for testing traps is observation. Without proper training, ultrasonic, acoustical, and pyrometric test methods can lead to erroneous conclusions.
8. Traps should be properly sized for the expected condensate load. Improper sizing can cause steam losses, freezing, and mechanical failures.
9. Condensate collection systems should be properly designed to minimize frozen and/or premature trap failures. Condensate piping should be sized to accommodate 10% of the traps failing to open.

For the case of fixed orifice traps, there is the possibility that on light loads these traps will pass live steam. There is also a tendency to waterlog under wide load variations. They can become clogged due to particulate buildup in the orifice and at times impurities can cause erosion and damage the orifice size, causing a blow-by of steam.

7.3.6 Diagnostic Tools

- Thermography – An infrared thermometer or camera allows for an accurate, non-contact assessment of temperature. Applications for steam traps include testing for proper function and insulation assessments around the traps. More information on thermography can be found in Chapter 6.
- Ultrasonic analyzer – Steam traps emit very distinct sound patterns; each trap type is said to have a particular signature. These sounds are not audible to the unaided ear. Using an ultrasonic detector, the analyst is able to isolate the frequency of sound being emitted by the steam trap, compare it to trended sound signatures, and make an assessment. Changes in these ultrasonic wave emissions are indicative of changes in steam trap function. More information on ultrasonic analysis can be found in Chapter 6.

7.3.7 Case Studies

1986 Event at a Major Research Government Facility (DOE 2001b)

On October 10, 1986, a condensate-induced water hammer at a major research government facility injured four steamfitters—two of them fatally. One of the steamfitters attempted to activate an 8-inch steam line located in a manhole. He noticed that there was no steam in either the steam line or the steam trap assembly and concluded that the steam trap had failed. Steam traps are devices designed to automatically remove condensate (liquid) from steam piping while the steam system is operating in a steady state. Without shutting off the steam supply, he and another steamfitter replaced the trap and left.

Later the first steamfitter, his supervisor, and two other steamfitters returned and found the line held a large amount of condensate. They cracked open a gate valve to drain the condensate into an 8-inch main. They cracked the valve open enough to allow water to pass, but this was too far open to control the sudden movement of steam into the main after all the condensate had been removed. A series of powerful water hammer surges caused the gaskets on two blind flanges in the manhole to fail, releasing hot condensate and steam into the manhole. A photograph of one failed gasket is shown in Figure 7.3.7. All four steamfitters suffered external burns and steam inhalation. Two of them died as a result.

A Type A Accident Investigation Board determined that the probable cause of the event was a lack of procedures and training, resulting in operational error. Operators had used an in-line gate valve to remove condensate from a steam line under pressure instead of drains installed for that purpose.

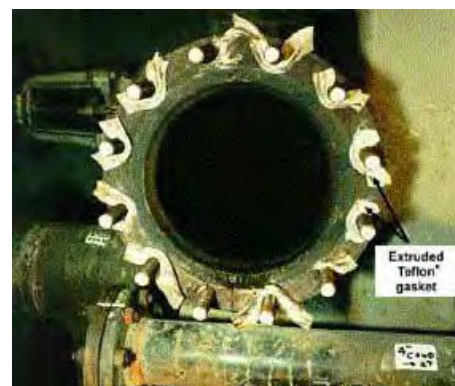

Figure 7.3.7. Failed gasket on blind flange.

The board also cited several management problems. There had been no Operational Readiness Review prior to system activation. Laboratory personnel had not witnessed all the hydrostatic and pressure testing, nor had all test results been submitted, as required by the contract. Documentation for design changes was inadequate. The board also determined that Brookhaven management had not been significantly involved in the activities of the steam shop.

1991 Event at a Georgia Hospital (DOE 2001c)

In June 1991, a valve gasket blew out in a steam system at a Georgia hospital. Operators isolated that section of the line and replaced the gasket. The section was closed for 2 weeks, allowing condensate to accumulate in the line. After the repair was completed, an operator opened the steam valve at the upstream end of the section. He drove to the other end and started to open the downstream steam valve. He did not open the blow-off valve to remove condensate before he opened the steam valve. Water hammer ruptured the valve before it was 20% open, releasing steam and condensate and killing the operator.

Investigators determined that about 1,900 pounds of water had accumulated at the low point in the line adjacent to the repaired valve, where a steam trap had been disconnected. Because the line was cold, the incoming steam condensed quickly, lowering the system pressure and accelerating the steam flow into the section. This swept the accumulated water toward the downstream valve and may have produced a relatively small steam-propelled water slug impact before the operator arrived. About 600 pounds of steam condensed in the cold section of the pipe before equilibrium was reached.

When the downstream valve was opened, the steam on the downstream side rapidly condensed into water on the upstream side. This flow picked up a 75 cubic foot slug of water about 400 feet downstream of the valve. The slug sealed off a steam pocket and accelerated until it hit the valve, causing it to rupture.

Investigators concluded that the accident could have been prevented if the operator had allowed the pipe to warm up first and if he had used the blow-off valve to remove condensate before opening the downstream valve.

Maintenance of Steam Traps

A steam trap assessment of three VA hospitals located in Providence, RI, Brockton, MA, and West Roxbury, MA was conducted with help of FEMP's SAVEnergy Program. The facilities are served by 15, 40, and 80 psig steam lines. The Providence system alone includes approximately 1,100 steam traps.

The assessment targeted steam trap performance and the value of steam losses from malfunctioning traps. The malfunctioning traps were designated for either repair or replacement. Included in this assessment was a training program on steam trap testing.

The cost of the initial steam trap audit was \$25,000 for the three facilities. Estimated energy savings totaled \$104,000. The cost of repair and replacement traps was about \$10,000. Thus, the cost savings of \$104,000 would pay for the implementation cost of \$35,000 in about 4 months.

7.3.8 Steam Traps Checklist

Description	Comments	Maintenance Frequency			
		Daily	Weekly	Monthly	Annually
Test steam traps	Daily/weekly test recommended for high-pressure traps (250 psig or more)	X			
Test steam traps	Weekly/monthly test recommended for medium-pressure traps (30-250 psig)		X		
Test steam traps	Monthly/annually test recommended for low-pressure traps			X	
Repair/replace steam traps	When testing shows problems. Typically, traps should be replaced every 3-4 years.			X	
Replace steam traps	When replacing, take the time to make sure traps are sized properly.				X

7.3.9 References

Avallone EA and T Baumeister, editors. 1986. *Marks' Standard Handbook for Mechanical Engineers*. 9th ed. McGraw-Hill, New York.

Climate Technology Initiative. April 7, 2001. *Steam Systems*. CTI Energy Efficiency Workshop, September 19-26, 1999, Yokkaichi, Japan [Online report]. Available URL: <http://www.climatetech.net/conferences/japan/pdf/chapt10.pdf>. Reprinted with permission of the Climate Technology Initiative.

Gorelik B. and A. Bandes. August 15, 2001. *Inspect Steam Traps for Efficient System*. [Online report]. Available URL: <http://www.maintenanceresources.com/ReferenceLibrary/SteamTraps/Inspect.htm>. Reprinted with permission of Mr. Bruce Gorelik.

U.S. Department of Energy (DOE). March 30, 2001a. *Steam Trap Performance Assessment*. Federal Technology Alerts, Pacific Northwest National Laboratory, July 1999 [Online report]. Available URL: http://www.pnl.gov/fta/15_steamtrap/15_steamtrap.htm.

U.S. Department of Energy (DOE). March 30, 2001b. *1986 Event at Brookhaven National Laboratory*. NFS Safety Notes, Issue No. 98-02, November 1998, Office of Operating Experience Analysis and Feedback, Office of Nuclear and Facility Safety [Online report]. Available URL: http://tis.eh.doe.gov/web/oeaf/lessons_learned/ons/sn9802.html.

U.S. Department of Energy (DOE). March 30, 2001c. *1991 Event at a Georgia Hospital*. NFS Safety Notes, Issue No. 98-02, November 1998, Office of Operating Experience Analysis and Feedback, Office of Nuclear and Facility Safety [Online report]. Available URL: http://tis.eh.doe.gov/web/oeaf/lessons_learned/ons/sn9802.html.

7.4 Chillers

7.4.1 Introduction

A chiller can be generally classified as a refrigeration system that cools water. Similar to an air conditioner, a chiller uses either a vapor-compression or absorption cycle to cool. Once cooled, chilled water has a variety of applications from space cooling to process uses.

7.4.2 Types of Chillers

7.4.2.1 Mechanical Compression Chiller (Dyer and Maples 1995)

The refrigeration cycle of a simple mechanical compression system is shown in Figure 7.4.1. The mechanical compression cycle has four basic components through which the refrigerant passes: (1) the evaporator, (2) the compressor, (3) the condenser, and (4) the expansion valve. The evaporator operates at a low pressure (and low temperature) and the condenser operates at high pressure (and temperature).

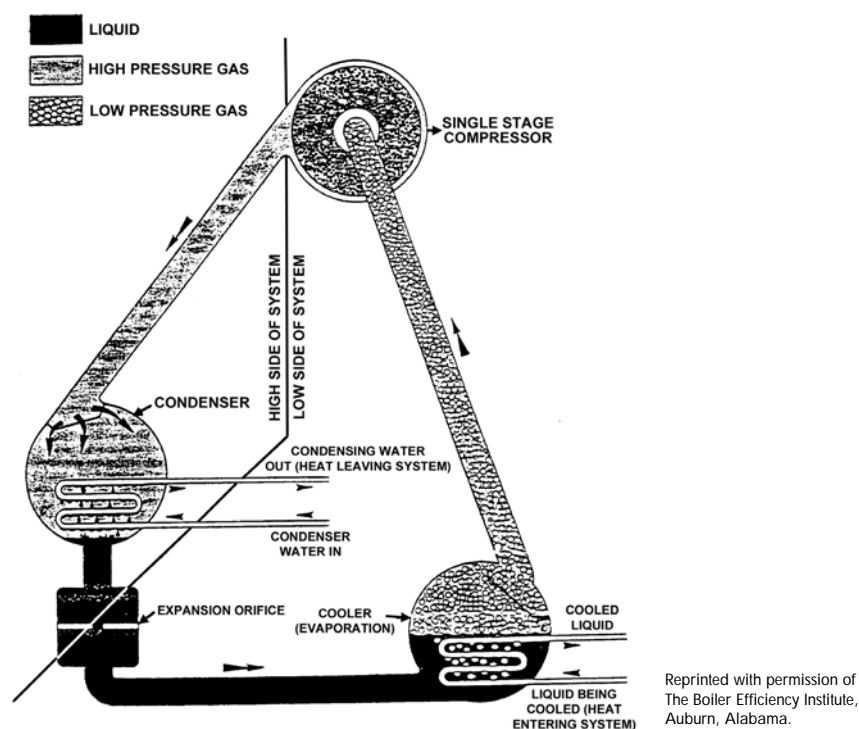

Figure 7.4.1. Basic cooling cycle-centrifugal unit using single-stage compressor.

The cycle begins in the evaporator where the liquid refrigerant flows over the evaporator tube bundle and evaporates, absorbing heat from the chilled water circulating through the tube bundle. The refrigerant vapor, which is somewhat cooler than the chilled water temperature, is drawn out of the evaporator by the compressor. The compressor “pumps” the refrigerant vapor to the condenser by raising the refrigerant pressure (and thus, temperature). The refrigerant condenses on the cooling water coils of the condenser giving up its heat to the cooling water. The high-pressure liquid refrigerant from the condenser then passes through the expansion device that reduces the refrigerant pressure

(and temperature) to that of the evaporator. The refrigerant again flows over the chilled water coils absorbing more heat and completing the cycle.

Mechanical compression chillers are generally classified by compressor type: reciprocating, centrifugal, and screw.

- **Reciprocating** – This is a positive displacement machine that maintains fairly constant volumetric flow over a wide range of pressure ratios. They are almost exclusively driven by fixed speed electric motors.
- **Centrifugal** – This type of compressor raises the refrigerant pressure by imparting momentum to the refrigerant with a spinning impeller, then stagnating the flow in a diffuser section around the impeller tip. They are noted for high capacity with compact design. Typical capacities range from 100 to 10,000 tons.
- **Screw** – The screw or helical compressor is a positive displacement machine that has a nearly constant flow performance characteristic. The machine essentially consists of two mating helically grooved rotors, a male (lobes) and a female (gullies), in a stationary housing. As the helical rotors rotate, the gas is compressed by direct volume reduction between the two rotors.

7.4.2.2 Absorption Chiller

(Dyer and Maples 1995)

The absorption and the mechanical compression cycles have the evaporation and condensation of a refrigerant in common. In both cycles, the refrigerant evaporates at low pressure (and low temperature) to absorb heat and then condenses at higher pressure (and higher temperature) to reject heat to the atmosphere. Both cycles require energy to raise the temperature of the refrigerant for the heat rejection process. In the mechanical compression cycle, the energy is supplied in the form of work to the compressor whereas in the absorption cycle, heat is added (usually steam) to raise the refrigerant temperature.

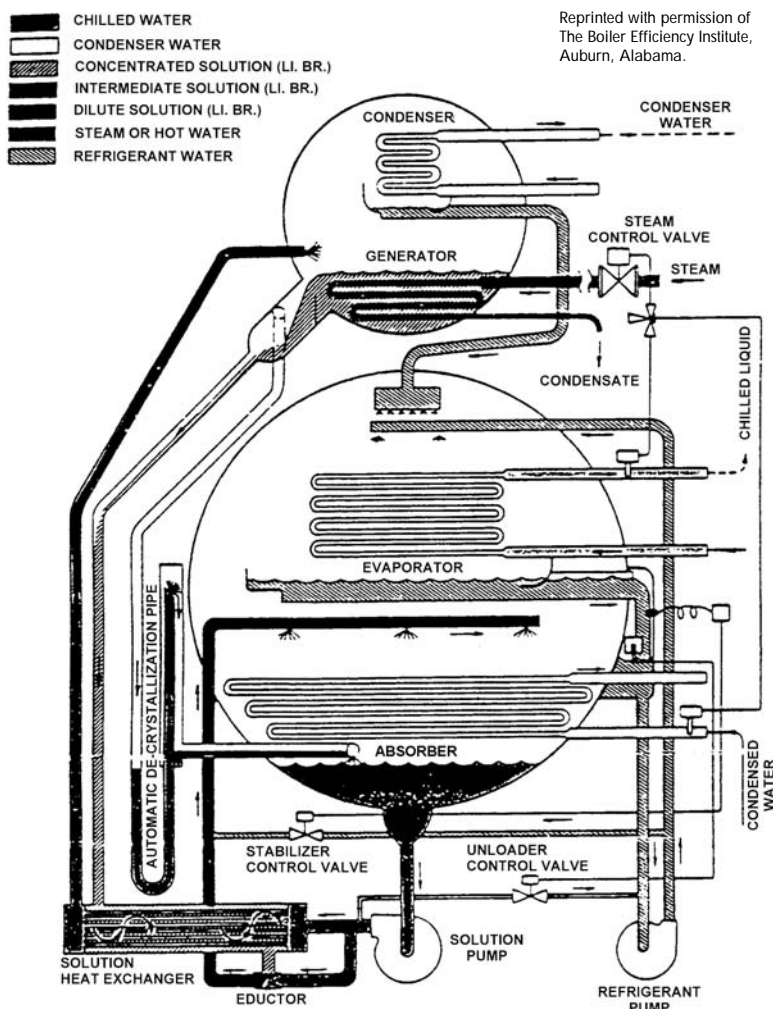

Figure 7.4.2. Schematic of typical absorption chiller.

The absorption cycle requires two working fluids: a refrigerant and an absorbent. Of the many combinations of refrigerant and absorbent that have been tried, only lithium bromide-water and ammonia-water cycles are commonly used today.

7.4.3 Key Components (Dyer and Maples 1995)

7.4.3.1 Mechanical Compression Chillers

- **Evaporator** – Component in which liquid refrigerant flows over a tube bundle and evaporates, absorbing heat from the chilled water circulating through the tube bundle.
- **Compressor** – “Pumps” the refrigerant vapor to the condenser by raising the refrigerant pressure (and thus, temperature).
- **Condenser** – Component in which refrigerant condenses on a set of cooling water coils giving up its heat to the cooling water.
- **Expansion Valve** – The high-pressure liquid refrigerant coming from the condenser passes through this expansion device, reducing the refrigerant’s pressure (and temperature) to that of the evaporator.

7.4.3.2 Absorption Chiller

The absorption cycle is made up of four basic components:

- **Evaporator** – Where evaporation of the liquid refrigerant takes place.
- **Absorber** – Where concentrated absorbent is sprayed through the vapor space and over condensing water coils. Since the absorbent has a strong attraction for the refrigerant, the refrigerant is absorbed with the help of the cooling water coils.
- **Generator** – Where the dilute solution flows over the generator tubes and is heated by the steam or hot water.
- **Condenser** – Where the refrigerant vapor from the generator releases its heat of vaporization to the cooling water as it condenses over the condenser water tube bundle.

7.4.4 Safety Issues (TARAP 2001)

Large chillers are most commonly located in mechanical equipment rooms within the building they are air conditioning. If a hazardous refrigerant is used (e.g., ammonia), the equipment room must meet additional requirements typically including minimum ventilation airflows and vapor concentration monitoring.

In many urban code jurisdictions, the use of ammonia as a refrigerant is prohibited outright. For large chillers, the refrigerant charge is too large to allow hydrocarbon refrigerants in chillers located in a mechanical equipment room.

7.4.5 Cost and Energy Efficiency (Dyer and Maples 1995)

The following steps describe ways to improve chiller performance, therefore, reducing its operating costs:

- Raise chilled water temperature – The energy input required for any liquid chiller (mechanical compression or absorption) increases as the temperature lift between the evaporator and the condenser increases. Raising the chilled water temperature will cause a corresponding increase in the evaporator temperature and thus, decrease the required temperature lift.

On a centrifugal chiller, if the chilled water temperature is raised by 2°F to 3°F, the system efficiency can increase by as much as 3% to 5%.

- Reduce condenser water temperature – The effect of reducing condenser water temperature is very similar to that of raising the chilled water temperature, namely reducing the temperature lift that must be supplied by the chiller.

On a centrifugal chiller, if the condenser water temperature is decreased by 2°F to 3°F, the system efficiency can increase by as much as 2% to 3%.

- Reducing scale or fouling – The heat transfer surfaces in chillers tends to collect various mineral and sludge deposits from the water that is circulated through them. Any buildup insulates the tubes in the heat exchanger causing a decrease in heat exchanger efficiency and thus, requiring a large temperature difference between the water and the refrigerant.
- Purge air from condenser – Air trapped in the condenser causes an increased pressure at the compressor discharge. This results in increased compressor horsepower. The result has the same effect as scale buildup in the condenser.
- Maintain adequate condenser water flow – Most chillers include a filter in the condenser water line to remove material picked up in the cooling tower. Blockage in this filter at higher loads will cause an increase in condenser refrigerant temperature due to poor heat transfer.
- Reducing auxiliary power requirements – The total energy cost of producing chilled water is not limited to the cost of operating the chiller itself. Cooling tower fans, condenser water circulating pumps, and chilled water circulating pumps must also be included. Reduce these requirements as much as possible.
- Use variable speed drive on centrifugal chillers – Centrifugal chillers are typically driven by fixed speed electric motors. Practical capacity reduction may be achieved with speed reductions, which in turn requires a combination of speed control and prerotation vanes.
- Compressor changeouts – In many installations, energy saving measures have reduced demand to the point that existing chillers are tremendously oversized, forcing the chiller to operate at greatly reduced loads even during peak demand times. This causes a number of problems including surging and poor efficiency. Replacing the compressor and motor drive to more closely match the observed load can alleviate these problems.
- Use free cooling – Cooling is often required even when outside temperatures drop below the minimum condenser water temperature. If outside air temperature is low enough, the chiller should be shut off and outside air used. If cooling cannot be done with outside air, a chiller bypass can be used to produce chilled water without the use of a chiller.

- Operate chillers at peak efficiency – Plants having two or more chillers can save energy by load management such that each chiller is operated to obtain combined peak efficiency. An example of this is the use of a combination of reciprocating and centrifugal compressor chillers.
- Heat recovery systems – Heat recovery systems extract heat from the chilled liquid and reject some of that heat, plus the energy of compression, to warm water circuit for reheat and cooling.
- Use absorption chilling for peak shaving – In installations where the electricity demand curve is dominated by the demand for chilled water, absorption chillers can be used to reduce the overall electricity demand.
- Replace absorption chillers with electric drive centrifugals – Typical absorption chillers require approximately 1.6 Btu of thermal energy delivered to the chiller to remove 1 Btu of energy from the chilled water. Modern electric drive centrifugal chillers require only 0.2 Btu of electrical energy to remove 1 Btu of energy from the chilled water (0.7 kw/ton).
- Thermal storage – The storage of ice for later use is an increasingly attractive option since cooling is required virtually year-round in many large buildings across the country. Because of utility demand charges, it is more economical to provide the cooling source during non-air conditioning periods and tap it when air conditioning is needed, especially peak periods.

7.4.6 Maintenance of Chillers (Trade Press Publishing Corporation 2001)

Similar to boilers, effective maintenance of chillers requires two activities: first, bring the chiller to peak efficiency and second, maintain that peak efficiency. There are some basic steps facility professionals can take to make sure their building's chillers are being maintained properly. Among them are:

- Inspecting the chiller as recommended by the chiller manufacturer. Typically, this should be done at least quarterly.
- Routine inspection for refrigerant leaks.
- Checking compressor operating pressures.
- Checking all oil levels and pressures.
- Examining all motor voltages and amps.
- Checking all electrical starters, contactors, and relays.
- Checking all hot gas and unloader operations.
- Using superheat and subcooling temperature readings to obtain a chiller's maximum efficiency.
- Taking discharge line temperature readings.

7.4.7 Diagnostic Tools

- **Thermography** – An infrared thermometer or camera allows for an accurate, non-contact assessment of temperature. Applications for chillers include insulation assessments on chilled water piping as well as motor/bearing temperature assessments on compressors and pumping systems. More information on thermography can be found in Chapter 6.

- **Ultrasonic analyzer** – Most rotating equipment and many fluid systems emit sound patterns in the ultrasonic frequency spectrum. Changes in these ultrasonic wave emissions are indicative of changes in equipment condition. Applications for chillers include compressor and chilled water pumping systems (bearing wear, etc.). Analyzers can also be used to identify refrigerant leaks. More information on ultrasonic analysis can be found in Chapter 6.

7.4.8 Chillers Checklist

Description	Comments	Maintenance Frequency			
		Daily	Weekly	Semi-Annually	Annually
Chiller use/sequencing	Turn off/sequence unnecessary chillers	X			
Overall visual inspection	Complete overall visual inspection to be sure all equipment is operating and safety systems are in place	X			
Check setpoints	Check all setpoints for proper setting and function	X			
Evaporator and condenser coil fouling	Assess evaporator and condenser coil fouling as required		X		
Compressor motor temperature	Check temperature per manufacturer's specifications		X		
Perform water quality test	Check water quality for proper chemical balance		X		
Leak testing	Conduct leak testing on all compressor fittings, oil pump joints and fittings, and relief valves		X		
Check all insulation	Check insulation for condition and appropriateness		X		
Control operation	Verify proper control function including: <ul style="list-style-type: none"> • Hot gas bypass • Liquid injection 		X		
Check vane control settings	Check settings per manufacturer's specification			X	
Verify motor load limit control	Check settings per manufacturer's specification			X	
Verify load balance operation	Check settings per manufacturer's specification			X	
Check chilled water reset settings and function	Check settings per manufacturer's specification			X	
Check chiller lockout setpoint	Check settings per manufacturer's specification				X
Clean condenser tubes	Clean tubes at least annually as part of shutdown procedure				X

Chillers Checklist (contd)

Description	Comments	Maintenance Frequency			
		Daily	Weekly	Semi-Annually	Annually
Eddy current test condenser tubes	As required, conduct eddy current test to assess tube wall thickness				X
Clean evaporator tubes	Clean tubes at least annually as part of shutdown procedure				X
Eddy current test evaporator tubes	As required, conduct eddy current test to assess tube wall thickness				X
Compressor motor and assembly	<ul style="list-style-type: none"> • Check all alignments to specification • Check all seals, provide lubrication where necessary 				X
Compressor oil system	<ul style="list-style-type: none"> • Conduct analysis on oil and filter • Change as required • Check oil pump and seals • Check oil heater and thermostat • Check all strainers, valves, etc. 				X
Electrical connections	Check all electrical connections/terminals for contact and tightness				X
Water flows	Assess proper water flow in evaporator and condenser				X
Check refrigerant level and condition	Add refrigerant as required. Record amounts and address leakage issues.				X

7.4.9 References

Dyer D.F. and G. Maples. 1995. *HVAC Efficiency Improvement*. Boiler Efficiency Institute, Auburn, Alabama.

The Alliance for Responsible Atmospheric Policy (TARAP). August 3, 2001. *Arthur D. Little Report, Section 7 Chiller*. [Online report]. Available URL: <http://www.arap.org/adlittle/7.html>.

Trade Press Publishing Corporation. August 6, 2001. Energy Decisions, May 2000, *Chiller Preventive Maintenance Checklist*. [Online]. Available URL: <http://www.facilitiesnet.com/fn/NS/NS3n0eb.html> | ticket=1234567890123456789112925988.

U.S. Department of Energy (DOE). August 4, 2001. *Incorrect Coolant Fluid Added to Chiller, 2000-RL-HNF-0011, Lessons Learned Information Services*. [Online report]. Available URL: http://tis.eh.doe.gov/ll/lldb/detail.CFM?Lessons__IdentifierIntern=2000%2DRL%2DHNF%2D0011.

7.5 Cooling Towers

7.5.1 Introduction

A cooling tower is a specialized heat exchanger in which two fluids (air and water) are brought into direct contact with each other to affect the transfer of heat. In a “spray-filled” tower, this is accomplished by spraying a flowing mass of water into a rain-like pattern, through which an upward moving mass flow of cool air is induced by the action of a fan (Marley Cooling Technologies 2001a).

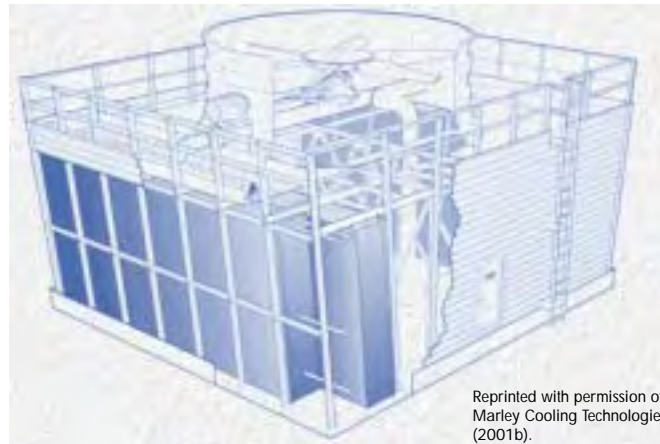

Figure 7.5.1. Cooling tower

7.5.2 Types of Cooling Towers

There are two basic types of cooling towers, direct or open and indirect or closed.

1. Direct or open cooling tower (Figure 7.5.2)

This type of system exposes the cooling water directly to the atmosphere. The warm cooling is sprayed over a fill in the cooling tower to increase the contact area, and air is blown through the fill. The majority of heat removed from the cooling water is due to evaporation. The remaining cooled water drops into a collection basin and is recirculated to the chiller (WSUCEEP 2001).

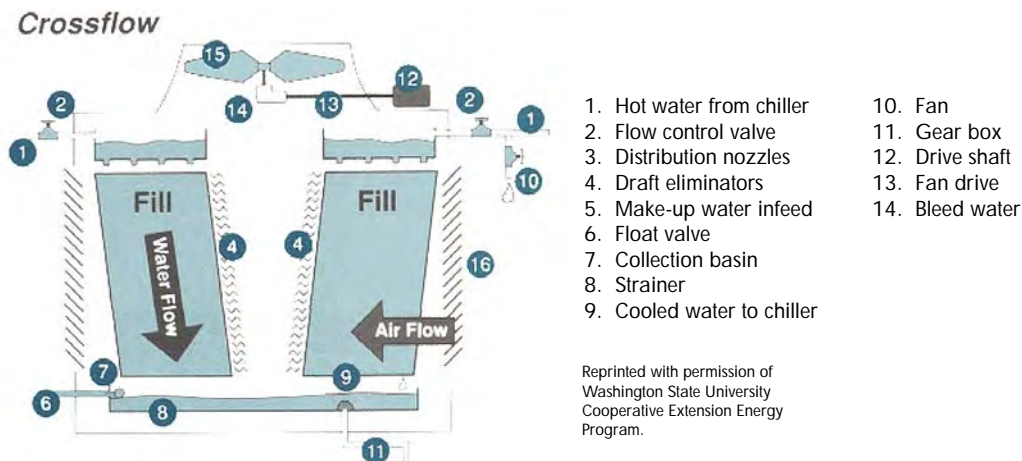

Figure 7.5.2. Direct or open cooling tower

2. Indirect or closed cooling tower

An indirect or closed cooling tower circulates the water through tubes located in the tower. In this type of tower, the cooling water does not come in contact with the outside air and represents a “closed” system.

7.5.3 Key Components

A cooling tower is a collection of systems that work together. Following is an overview of how these systems operate.

Hot water from a chilled water system is delivered to the top of the cooling tower by the condenser pump through distribution piping. The hot water is sprayed through nozzles onto the heat transfer media (fill) inside the cooling tower. Some towers feed the nozzles through pressurized piping; others use a water distribution basin and feed the nozzles through gravity.

A cold-water collection basin at the base of the tower gathers cool water after it has passed through the heat transfer media. The cool water is pumped back to the condenser to complete the cooling water loop.

Cooling towers use evaporation to release waste heat from a HVAC system. Hot water flowing from the condenser is slowed down and spread out in the heat transfer media (fill). A portion of the hot water is evaporated in the fill area, which cools the bulk water. Cooling tower fill is typically arranged in packs of thin corrugated plastic sheets or, alternately, as splash bars supported in a grid pattern.

Large volumes of air flowing through the heat transfer media help increase the rate of evaporation and cooling capacity of the tower. This airflow is generated by fans powered by electric motors. The cooling tower fan size and airflow rate are selected for the desired cooling at the design conditions of hot water, cold water, water flow rate, and wet bulb air temperature.

HVAC cooling tower fans may be propeller type or squirrel cage blowers, depending on the tower design. Small fans may be connected directly to the driving motor, but most designs require an intermediate speed reduction provided by a power belt or reduction gears. The fan and drive system operates in conjunction with a starter and control unit that provides start/stop and speed control.

As cooling air moves through the fill, small droplets of cooling water become entrained and can exit the cooling tower as carry-over or drift. Devices called drift eliminators are used to remove carry-over water droplets. Cooling tower drift becomes an annoyance when the droplets fall on people and surfaces downwind from the cooling tower. Efficient drift eliminators remove virtually all of the entrained cooling water droplets from the air stream (Suptic 1998).

7.5.4 Safety Issues

Warm water in the cooling system is a natural habitat for microorganisms. Chemical treatment is required to eliminate this biological growth. Several acceptable biocides are available from water treatment companies for this purpose. Cooling towers must be thoroughly cleaned on a periodic basis to minimize bacterial growth. Unclean cooling towers promote growth of potentially infectious bacteria, including *Legionella Pneumophila* (Suptic 1998).

Legionella may be found in water droplets from cooling towers, which may become airborne and become a serious health hazard if inhaled by a human. The lung is a warm and moist environment, which presents perfect conditions for the growth of such a disease. Common symptoms on patients with legionnaires disease are cough, chills, and fever. In addition, muscle aches, headache, tiredness, loss of appetite, and, occasionally, diarrhea can also be present. Laboratory tests may show decreased function of the kidneys. Chest x-rays often show pneumonia.

7.5.5 Cost and Energy Efficiency

An improperly maintained cooling tower will produce warmer cooling water, resulting in higher condenser temperatures than a properly maintained cooling tower. This reduces the efficiency of the chiller, wastes energy, and increases cost. The chiller will consume 2.5% to 3.5% more energy for each degree increase in the condenser temperature.

For example, if a 100-ton chiller costs \$20,000 in energy to operate each year, it will cost you an additional \$500 to \$700 per year for every degree increase in condenser temperature. Thus, for a 5°F to 10°F increase, you can expect to pay \$2,500 to \$7,000 a year in additional electricity costs. In addition, a poorly maintained cooling tower will have a shorter operating life, is more likely to need costly repairs, and is less reliable (WSUCEEP 2001).

7.5.6 Maintenance of Cooling Towers

Cooling tower maintenance must be an ongoing endeavor. Lapses in regular maintenance can result in system degradation, loss of efficiency, and potentially serious health issues.

General Requirements for Safe and Efficient Cooling Towers Provide: (Suptic 1998)

1. Safe access around the cooling tower, including all points where inspection and maintenance activities occur.
 2. Fall protection around inspection and maintenance surfaces, such as the top of the cooling tower.
 3. Lockout of fan motor and circulating pumps during inspection and maintenance.
 4. Protection of workers from exposure to biological and chemical hazards within the cooling water system.
 5. Cooling tower location must prevent cooling tower discharge air from entering the fresh air intake ducts of any building.
1. When starting the tower, inspect and remove any accumulated debris.
 2. Balance waterflow following the tower manufacturer's procedure to ensure even distribution of hot water to all areas of the fill. Poorly distributed water can lead to air bypass through the fill and loss of tower performance.
 3. Follow your water treating company's recommendations regarding chemical addition during startup and continued operation of the cooling system. Galvanized steel cooling towers require special passivation procedures during the first weeks of operation to prevent "white rust."
 4. Before starting the fan motor, check the tightness and alignment of drive belts, tightness of mechanical hold-down bolts, oil level in gear reducer drive systems, and alignment of couplings. Rotate the fan by hand and ensure that blades clear all points of the fan shroud.
 5. The motor control system is designed to start and stop the fan to maintain return cold water temperature. The fan motor must start and stop no more frequently than four to five times per hour to prevent motor overheating.
 6. Blowdown water rate from the cooling tower should be adjusted to maintain between two to four concentrations of dissolved solids.

7.5.7 Common Causes of Cooling Towers Poor Performance

- **Scale Deposits** – When water evaporates from the cooling tower, it leaves scale deposits on the surface of the fill from the minerals that were dissolved in the water. Scale build-up acts as a barrier to heat transfer from the water to the air. Excessive scale build-up is a sign of water treatment problems.
- **Clogged Spray Nozzles** – Algae and sediment that collect in the water basin as well as excessive solids that get into the cooling water can clog the spray nozzles. This causes uneven water distribution over the fill, resulting in uneven air flow through the fill and reduced heat transfer surface area. This problem is a sign of water treatment problems and clogged strainers.
- **Poor Air Flow** – Poor air flow through the tower reduces the amount of heat transfer from the water to the air. Poor air flow can be caused by debris at the inlets or outlets of the tower or in the fill. Other causes of poor air flow are loose fan and motor mountings, poor motor and fan alignment, poor gear box maintenance, improper fan pitch, damage to fan blades, or excessive vibration. Reduced air flow due to poor fan performance can ultimately lead to motor or fan failure.
- **Poor Pump Performance** – An indirect cooling tower uses a cooling tower pump. Proper water flow is important to achieve optimum heat transfer. Loose connections, failing bearings, cavitation, clogged strainers, excessive vibration, and non-design operating conditions result in reduced water flow, reduced efficiency, and premature equipment failure (WSUCEEP 2001).

7.5.8 Diagnostic Tools

- **Thermography** – An infrared thermometer or camera allows for an accurate, non-contact assessment of temperature. Applications for cooling towers include bearing and electrical contact assessments on motor and fan systems as well as hot spots on belt and other drive systems. More information on thermography can be found in Chapter 6.
- **Ultrasonic analyzer** - Electric motor and fan systems emit very distinct sound patterns around bearings and drives (direct or belt). In most cases, these sounds are not audible to the unaided ear, or are drown-out by other equipment noises. Using an ultrasonic detector, the analyst is able to isolate the frequency of sound being emitted by the bearing or drive. Changes in these ultrasonic wave emissions are indicative of changes in equipment condition-some of these changes can be a precursor to component degradation and failure. More information on ultrasonic analysis can be found in Chapter 6.

7.5.9 Cooling Towers Checklist

Description	Comments	Maintenance Frequency			
		Daily	Weekly	Monthly	Annually
Cooling tower use/ sequencing	Turn off/sequence unnecessary cooling towers	X			
Overall visual inspection	Complete overall visual inspection to be sure all equipment is operating and safety systems are in place	X			
Inspect for clogging	Make sure water is flowing in tower	X			
Fan motor condition	Check the condition of the fan motor through temperature or vibration analysis and compare to baseline values		X		
Clean suction screen	Physically clean screen of all debris		X		
Test water samples	Test for proper concentrations of dissolved solids, and chemistry. Adjust blowdown and chemicals as necessary.		X		
Operate make-up water float switch	Operate switch manually to ensure proper operation		X		
Vibration	Check for excessive vibration in motors, fans, and pumps		X		
Check tower structure	Check for loose fill, connections, leaks, etc.		X		
Check belts and pulleys	Adjust all belts and pulleys		X		
Check lubrication	Assure that all bearings are lubricated per the manufacturer's recommendation			X	
Check motor supports and fan blades	Check for excessive wear and secure fastening			X	
Motor alignment	Aligning the motor coupling allows for efficient torque transfer			X	
Check drift eliminators, louvers, and fill	Look for proper positioning and scale build up			X	
Clean tower	Remove all dust, scale, and algae from tower basin, fill, and spray nozzles				X
Check bearings	Inspect bearings and drive belts for wear. Adjust, repair, or replace as necessary.				X
Motor condition	Checking the condition of the motor through temperature or vibration analysis assures long life				X

7.5.10 References

Hanaro, Korea Atomic Research Institute. April 12, 2001. *Cooling Tower*. [Online]. Available URL: <http://hpngp01.kaeri.re.kr/hanaro/photo/cooltower.html>.

Marley Cooling Technologies. July 6, 2001a. *Cooling Information Index*. [Online report]. Available URL: http://www.marleyct.com/pdf_forms/CTII-1.pdf. Reprinted with permission of Marley Cooling Technologies.

Marley Cooling Technologies. September 2, 2002b. *Sigma F Series*. [Online report]. Available URL: <http://www.marleyct.com/sigmafseries.htm>. Reprinted with permission of Marley Cooling Technologies.

Suptic D.M. April 13, 2001. *A Guide to Trouble-Free Cooling Towers: A basic understanding of cooling tower operation and maintenance will help keep a cooling water system running in top condition, year after year*, June 1998, RSES Journal. [Online report]. Available URL: <http://www.pace-incorporated.com/maint1.htm>. Reprinted with permission of RSES Journal.

Washington State University Cooperative Extension Energy Program (WSUCEEP). April 24, 2001. *Optimizing Cooling Tower Performance*, WSUEEP98013 [Online report]. Available URL: http://www.es.wapa.gov/pubs/briefs/cooling/tb_cool.cfm. Reprinted with permission of Washington State University Cooperative Extension Energy Program.

7.6 Energy Management/Building Automation Systems

7.6.1 Introduction

The objective of an energy management/building automation system (also known as an energy management and control system [EMCS]) is to achieve an optimal level of control of occupant comfort while minimizing energy use. These control systems are the integrating component to fans, pumps, heating/cooling equipment, dampers, mixing boxes, and thermostats. Monitoring and optimizing temperature, pressure, humidity, and flow rates are key functions of modern building control systems.

ASDMaster: Adjustable Speed Drive Evaluation Methodology and Application Software

This Windows software program helps you, as a plant or operations professional, determine the economic feasibility of an ASD application, predict how much electrical energy may be saved by using an ASD, and search a database of standard drives.

Available from:
The Electric Power Research Institute
<http://www.epri-peac.com/asdmaster/>.

7.6.2 System Types

At the crudest level of energy management and control is the manual operation of energy using devices; the toggling on and off of basic comfort and lighting systems based on need. The earliest forms of energy management involved simple time clock- and thermostat-based systems; indeed, many of these systems are still being used. Typically, these systems are wired directly to the end-use equipment and mostly function autonomously from other system components. Progressing with technology and the increasing economic availability of microprocessor-based systems, energy management has quickly moved to its current state of computer based, digitally controlled systems.

Direct digital control (DDC) systems function by measuring particular system variables (temperature, for instance), processing those variables (comparing a measured temperature to a desired setpoint), and then signaling a terminal device (air damper/mixing box) to respond. With the advent of DDC systems, terminal devices are now able to respond quicker and with more accuracy to a given input. This increased response is a function of the DDC system capability to control devices in a nonlinear fashion. Control that once relied on linear “hunting” to arrive at the desired setpoint now is accomplished through sophisticated algorithms making use of proportional and integral (PI) control strategies to arrive at the setpoint quicker and with more accuracy.

7.6.3 Key Components

The hardware making up modern control systems have three necessary elements: sensors, controllers, and the controlled devices.

- **Sensors** – There is an increasing variety and level of sophistication of sensors available for use with modern control systems. Some of the more common include: temperature, humidity, pressure, flow rate, and power. Becoming more common are sensors that track indoor air quality, lighting level, and fire/smoke.

- **Controllers** – The function of the controller is to compare a signal received from the sensor to a desired setpoint, and then send out a corresponding signal to the controlled device for action. Controllers may be very simple such as a thermostat where the sensor and controller are usually co-located, to very sophisticated microprocessor based systems capable of powerful analysis routines.
- **Controlled devices** – The controlled device is the terminal device receiving the signal from the controller. Amongst others, typical controlled devices include: air dampers, mixing boxes, control valves, and in some cases, fans, pumps, and motors.

7.6.4 Safety Issues

The introduction of outdoor air is the primary means for dilution of potentially harmful contaminants. Because an EMCS has the capability to control ventilation rates and outdoor-air volumes, certain health and safety precautions need to be taken to ensure proper operation and air quality. Regular checks of contaminant levels, humidity levels, and proper system operation are recommended.

A modern EMCS is capable of other control functions including fire detection and fire suppression systems. As these systems take on other roles, roles that now include responsibilities for personal safety, their operations and maintenance must be given the highest priority.

7.6.5 Cost and Efficiency

Simply installing an EMCS does not guarantee that a building will save energy. Proper installation and commissioning are prerequisites for optimal operation and realizing potential savings. While it is beyond the scope of this guide to detail all the possible EMCS savings strategies, some of the more common functions are presented below.

- **Scheduling** – An EMCS has the ability to schedule the HVAC system for night setback, holiday/weekend schedules (with override control), optimal start/stop, and morning warm-up/cool-down functions.
- **Resets** – Controlling and resetting temperatures of supply air, mixed air, hot water, and chilled water optimize the overall systems for efficiency.
- **Economizers** – Controlling economizer functions with an EMCS helps to assure proper integration and function with other system components. Strategies include typical air-side functions (i.e., economizer use tied to inside setpoints and outside temperatures) and night-time ventilation (purge) operations.
- **Advanced functionality** – A more sophisticated EMCS has expended capabilities including chiller/boiler staging, variable speed drive control, zoned and occupancy-based lighting control, and electrical demand limiting.

7.6.6 Maintenance

The ability of an EMCS to efficiently control energy use in a building is a direct function of the data provided to the EMCS. The old adage ‘garbage in - garbage out’ could not hold more truth than in an EMCS making decisions based on a host of sensor inputs.

For a number of reasons, the calibration of sensors is an often overlooked activity. In many ways, sensors fall into the same category as steam traps: if it doesn't 'look' broken - don't fix it. Unfortunately, as with steam traps, sensors out of calibration can lead to enormous energy penalties. Furthermore, as with steam traps, these penalties can go undetected for years without a proactive maintenance program.

The following is a list of sensors and actuators that will most need calibration (PECI 1997):

- Outside air temperature
- Mixed air temperature
- Return air temperature
- Discharge or supply air temperature
- Coil face discharge air temperatures
- Chilled water supply temperature
- Condenser entering water temperature
- Heating water supply temperature
- Wet bulb temperature or RH sensors
- Space temperature sensors
- Economizer and related dampers
- Cooling and heating coil valves
- Static pressure transmitters
- Air and water flow rates
- Terminal unit dampers and flows.

Are You Calibrated?

Answer the following questions to determine if your system or equipment needs calibration (PECI 1997):

1. Are you sure your sensors and actuators were calibrated when originally installed?
2. Have your sensors or actuators been calibrated since?
3. Have temperature complaints come from areas that ought to be comfortable?
4. Are any systems performing erratically?
5. Are there areas or equipment that repeatedly have comfort or operational problems?

Sensor and actuator calibration should be an integral part of all maintenance programs.

7.6.7 Diagnostic Tools

- **Calibration** – All energy management systems rely on sensors for proper feedback to adjust to efficient conditions. The accuracy with which these conditions are reached is a direct function of the accuracy of the sensor providing the feedback. Proper and persistent calibration activities are a requirement for efficient conditions.

7.6.8 Case Studies

Benefit of O&M Controls Assessments (PECI 1999)

A 250,000 square foot office building in downtown Nashville, Tennessee, was renovated in 1993. The renovation included installing a DDC energy management control system to control the variable air volume (VAV) HVAC system and lighting and a variable frequency drive (VFD) for the chilled water system. The building was not commissioned as part of the renovation. An O&M assessment was performed 3 years later because the building was experiencing problems and energy bills seemed

higher than expected. As a result of the assessment, a total of 32 O&M related problems including a major indoor air quality (IAQ) deficiency were identified. It was also determined that the majority of these problems had been present since the renovation. Annual energy savings from the recommended O&M improvements and repairs are estimated at \$9,300. The simple payback for both the assessment and implementation is under 7 months.

7.6.9 Building Controls Checklist

Description	Comments	Maintenance Frequency			
		Daily	Weekly	Semi-Annually	Annually
Overall visual inspection	Complete overall visual inspection to be sure all equipment is operating and safety systems are in place	X			
Verify control schedules	Verify in control software that schedules are accurate for season, occupancy, etc.	X			
Verify setpoints	Verify in control software that setpoints are accurate for season, occupancy, etc.	X			
Time clocks	Reset after every power outage	X			
Check all gauges	Check all gauges to make sure readings are as expected		X		
Control tubing (pneumatic system)	Check all control tubing for leaks		X		
Check outside air volumes	Calculated the amount of outside air introduced and compare to requirements		X		
Check setpoints	Check setpoints and review rational for setting		X		
Check schedules	Check schedules and review rational for setting		X		
Check deadbands	Assure that all deadbands are accurate and the only simultaneous heating and cooling is by design		X		
Check sensors	Conduct thorough check of all sensors - temperature, pressure, humidity, flow, etc. - for expected values			X	
Time clocks	Check for accuracy and clean			X	
Calibrate sensors	Calibrate all sensors: temperature, pressure, humidity, flow, etc.				X

7.6.10 References

PECI. 1997. *Energy Management Systems: A Practical Guide*. Portland Energy Conservation, Inc., Portland, Oregon.

PECI. 1999. *Operations and Maintenance Assessments*. Portland Energy Conservation, Inc. Published by the U.S. Environmental Protection Agency and the U.S. Department of Energy.

7.7 Pumps

7.7.1 Introduction

Keeping pumps operating successfully for long periods of time requires careful pump design selection, proper installation, careful operation, the ability to observe changes in performance over time, and in the event of a failure, the capacity to thoroughly investigate the cause of the failure and take measures to prevent the problem from recurring. Pumps that are properly sized and dynamically balanced, that sit on stable foundations with good shaft alignment and with proper lubrication, that operators start, run, and stop carefully, and that maintenance personnel observe for the appearance of unhealthy trends which could begin acting on and causing damage to, usually never experience a catastrophic failure (Piotrowski 2001).

Pumping System Assessment Tool (PSAT)

The Pumping System Assessment Tool helps industrial users assess the efficiency of pumping system operations. PSAT uses achievable pump performance data from Hydraulic Institute standards and motor performance data from the MotorMaster+ database to calculate potential energy and associated cost savings.

Available from:

U.S. Department of Energy
 Energy Efficiency and Renewable Energy Network
 (800) 363-3732
www.oit.doe.gov/bestpractices/motors/.

7.7.2 Types of Pumps

The family of pumps comprehends a large number of types based on application and capabilities.

The two major groups of pumps are dynamic and positive displacement.

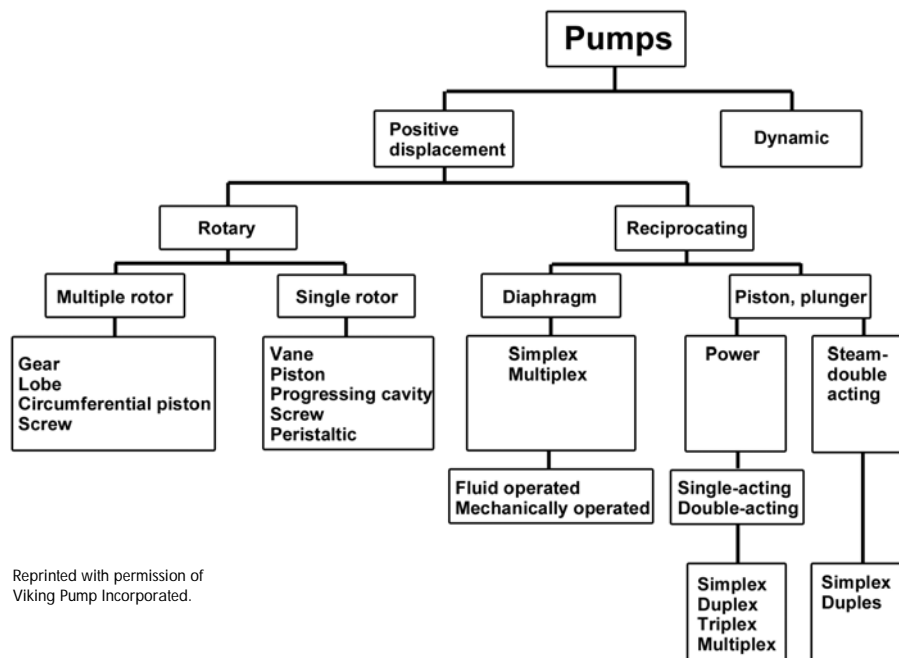

Reprinted with permission of Viking Pump Incorporated.

Figure 7.7.1. Technology tree for pumps.

7.7.2.1 Dynamic Pump (Centrifugal Pump) (Pump World 2001a)

Centrifugal pumps are classified into three general categories:

- **Radial flow** – a centrifugal pump in which the pressure is developed wholly by centrifugal force.
- **Mixed flow** – a centrifugal pump in which the pressure is developed partly by centrifugal force and partly by the lift of the vanes of the impeller on the liquid.
- **Axial flow** – a centrifugal pump in which the pressure is developed by the propelling or lifting action of the vanes of the impeller on the liquid.

7.7.2.2 Positive Displacement Pump (Pump World 2001c)

A positive displacement pump has an expanding cavity on the suction side of the pump and a decreasing cavity on the discharge side. Liquid is allowed to flow into the pump as the cavity on the suction side expands and the liquid is forced out of the discharge as the cavity collapses. This principle applies to all types of positive displacement pumps whether the pump is a rotary lobe, gear within a gear, piston, diaphragm, screw, progressing cavity, etc.

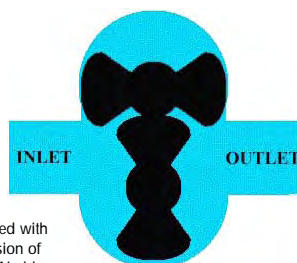

Reprinted with permission of Pump World.

Figure 7.7.2. Rotary lobe pump.

A positive displacement pump, unlike a centrifugal pump, will produce the same flow at a given rpm no matter what the discharge pressure is. A positive displacement pump cannot be operated against a closed valve on the discharge side of the pump, i.e., it does not have a shut-off head like a centrifugal pump does. If a positive displacement pump is allowed to operate against a closed discharge valve, it will continue to produce flow which will increase the pressure in the discharge line until either the line bursts or the pump is severely damaged or both (Pump World 2001d).

For purposes of this guide, positive displacement pumps are classified into two general categories and then subdivided into four categories each:

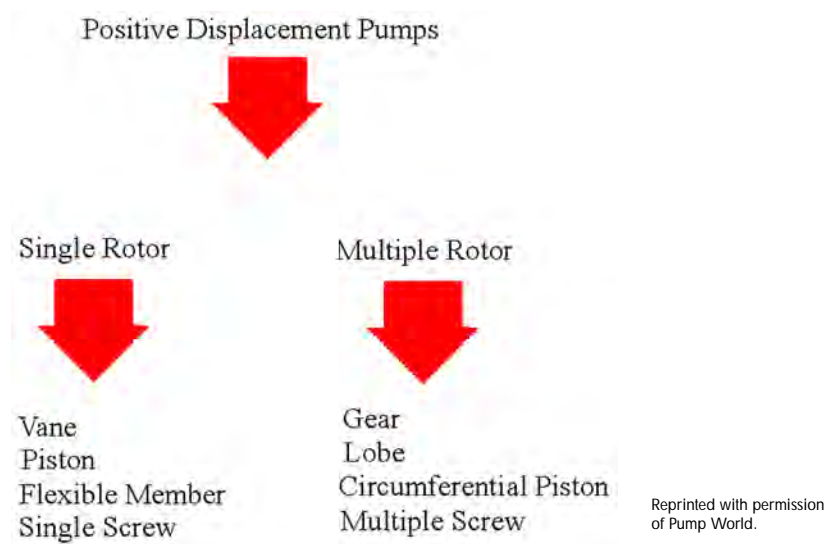

Reprinted with permission of Pump World.

Figure 7.7.3. Positive displacement pumps.

7.7.3 Key Components

7.7.3.1 Centrifugal Pump (Pump World 2001b)

The two main components of a centrifugal pump are the impeller and the volute.

The impeller produces liquid velocity and the volute forces the liquid to discharge from the pump converting velocity to pressure. This is accomplished by offsetting the impeller in the volute and by maintaining a close clearance between the impeller and the volute at the cut-water. Please note the impeller rotation. A centrifugal pump impeller slings the liquid out of the volute.

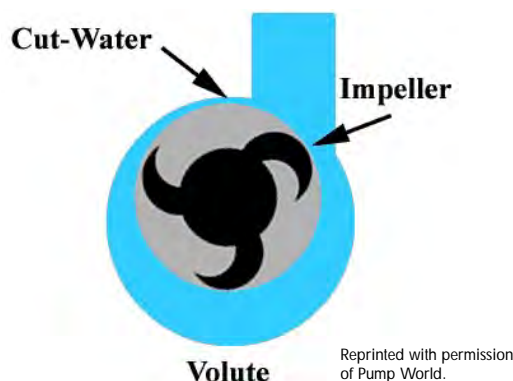

Figure 7.7.4. Centrifugal pump.

7.7.3.2 Positive Displacement Pumps

- Single Rotor (Pump World 2001d)
 - **Vane** – The vane(s) may be blades, buckets, rollers, or slippers that cooperate with a dam to draw fluid into and out of the pump chamber.
 - **Piston** – Fluid is drawn in and out of the pump chamber by a piston(s) reciprocating within a cylinder(s) and operating port valves.
 - **Flexible Member** – Pumping and sealing depends on the elasticity of a flexible member(s) that may be a tube, vane, or a liner.
 - **Single Screw** – Fluid is carried between rotor screw threads as they mesh with internal threads on the stator.
- Multiple Rotor (Pump World 2001d)
 - **Gear** – Fluid is carried between gear teeth and is expelled by the meshing of the gears that cooperate to provide continuous sealing between the pump inlet and outlet.
 - **Lobe** – Fluid is carried between rotor lobes that cooperate to provide continuous sealing between the pump inlet and outlet.
 - **Circumferential Piston** – Fluid is carried in spaces between piston surfaces not requiring contacts between rotor surfaces.
 - **Multiple Screw** – Fluid is carried between rotor screw threads as they mesh.

- Relief Valves (Pump World 2001e)

Note: A relief valve on the discharge side of a positive displacement pump is an absolute must!

- **Internal Relief Valve** - Pump manufacturers normally have an option to supply an internal relief valve. These relief valves will temporarily relieve the pressure on the discharge side of a pump operating against a closed valve. They are normally not full ported, i.e., cannot bypass all the flow produced by the pump. These internal relief valves should be used for pump protection against a temporary closing of a valve.
- **External Relief Valve** – An external relief valve (RV) installed in the discharge line with a return line back to the supply tank is highly recommended to provide complete protection against an unexpected over pressure situation.

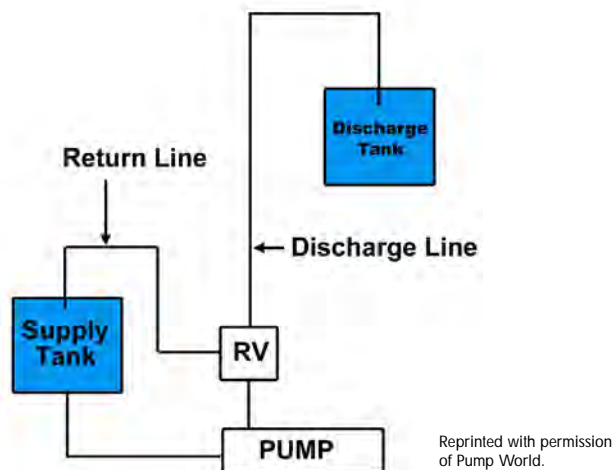

Figure 7.7.5. Schematic of pump and relief valve.

7.7.4 Safety Issues (Pompe Spec Incorporated 2001)

Some important safety tips related to maintenance actions for pumps:

- Safety apparel
 - Insulated work gloves when handling hot bearings or using bearing heater.
 - Heavy work gloves when handling parts with sharp edges, especially impellers.
 - Safety glasses (with side shields) for eye protection, especially in machine shop area.
 - Steel-toed shoes for foot protection when handling parts, heavy tools, etc.
- Safe operating procedures
 - Coupling guards: Never operate a pump without coupling guard properly installed.
 - Flanged connections:
 - Never force piping to make connection with pump.
 - Insure proper size, material, and number of fasteners are installed.
 - Beware of corroded fasteners.

- When operating pump:
 - Do not operate below minimum rated flow, or with suction/discharge valves closed.
 - Do not open vent or drain valves, or remove plugs while system is pressurized.
- Maintenance safety
 - Always lock out power.
 - Ensure pump is isolated from system and pressure is relieved before any disassembly of pump, removal of plugs, or disconnecting piping.
 - Pump and components are heavy. Failure to properly lift and support equipment could result in serious injury.
 - Observe proper decontamination procedures. Know and follow company safety regulations.
 - Never apply heat to remove impeller.

7.7.5 Cost and Energy Efficiency

Pumps frequently are asked to operate far off their best efficiency point, or are perched atop unstable base-plates, or are run under moderate to severe misalignment conditions, or, having been lubricated at the factory, are not given another drop of lubricant until the bearings seize and vibrate to the point where bolts come loose. When the unit finally stops pumping, new parts are thrown on the machine and the deterioration process starts all over again, with no conjecture as to why the failure occurred.

The following are measures that can improve pump efficiency (OIT 1995):

- Shut down unnecessary pumps.
- Restore internal clearances if performance has changed.
- Trim or change impellers if head is larger than necessary.
- Control by throttle instead of running wide-open or bypassing flow.
- Replace oversized pumps.
- Use multiple pumps instead of one large one.
- Use a small booster pump.
- Change the speed of a pump for the most efficient match of horsepower requirements with output.

Proper maintenance is vital to achieving top pump efficiency expected life. Additionally, because pumps are a vital part of many HVAC and process applications, their efficiency directly affects the efficiency of other system components. For example, an improperly sized pump can impact critical flow rates to equipment whose efficiency is based on these flow rates—a chiller is a good example of this.

The heart beats an average of 75 times per minute, or about 4,500 times per hour. While the body is resting, the heart pumps 2.5 ounces of blood per beat. This amount does not seem like much, but it sums up to almost 5 liters of blood pumped per minute by the heart, or about 7,200 liters per day. The amount of blood delivered by the heart can vary depending upon the body's need. During periods of great activity, such as exercising, the body demands higher amounts of blood, rich in oxygen and nutrients, increasing the heart's output by nearly five times.

7.7.6 Maintenance of Pumps

(General Service Administration 1995)

The importance of pumps to the daily operation of buildings and processes necessitates a proactive maintenance program. Most pump maintenance activities center on checking packing

Large Horsepower (25 horsepower and above) Pump Efficiency Survey (OIT 1995)

Actions are given in decreasing potential for efficiency improvement:

1. Excessive pump maintenance - this is often associated with one of the following:
 - Oversized pumps that are heavily throttled.
 - Pumps in cavitation.
 - Badly worn pumps.
 - Pumps that are misapplied for the present operation.
2. Any pump system with large flow or pressure variations. When normal flows or pressures are less than 75% of their maximum, energy is probably being wasted from excessive throttling, large bypass flows, or operation of unneeded pumps.
3. Bypassed flow, either from a control system or deadhead protection orifices, is wasted energy.
4. Throttled control valves. The pressure drop across a control valve represents wasted energy, that is proportional to the pressure drop and flow.
5. Fixed throttle operation. Pumps throttled at a constant head and flow indicate excess capacity.
6. Noisy pumps or valves. A noisy pump generally indicates cavitation from heavy throttling or excess flow. Noisy control valves or bypass valves usually mean a higher pressure drop with a corresponding high energy loss.
7. A multiple pump system. Energy is commonly lost from bypassing excess capacity, running unneeded pumps, maintaining excess pressure, or having a large flow increment between pumps.
8. Changes from design conditions. Changes in plant operating conditions (expansions, shutdowns, etc.) can cause pumps that were previously well applied to operate at reduced efficiency.
9. A low-flow, high-pressure user. Such users may require operation of the entire system at high pressure.
10. Pumps with known overcapacity. Overcapacity wastes energy because more flow is pumped at a higher pressure than required.

and mechanical seals for leakage, performing preventive/predictive maintenance activities on bearings, assuring proper alignment, and validating proper motor condition and function.

7.7.7 Diagnostic Tools

- **Ultrasonic analyzer** – Fluid pumping systems emit very distinct sound patterns around bearings and impellers. In most cases, these sounds are not audible to the unaided ear, or are drown-out by other equipment noises. Using an ultrasonic detector, the analyst is able to isolate the frequency of sound being emitted by the bearing or impeller. Changes in these ultrasonic wave emissions are indicative of changes in equipment condition-some of these changes can be a precursor to component degradation and failure. More information on ultrasonic analysis can be found in Chapter 6.
- **Vibration analyzer** – Within a fluid pump, there are many moving parts; some in rotational motion and some in linear motion. In either case, these parts generate a distinct pattern and

level of vibration. Using a vibration analyzer and signature analysis software, the analyst can discern the vibration amplitude of the point on the equipment being monitored. This amplitude is then compared with trended readings. Changes in these readings are indicative of changes in equipment condition. More information on vibration analysis can be found in Chapter 6.

7.7.8 Case Study (DOE 2001)

Pump Optimization for Sewage Pumping Station

The town of Trumbull, CT was looking for a way to increase the operating performance of one of its ten sewage-pumping stations. The station consisted of two identical sewage-handling pumps (each with a 40-hp direct drive motor) vertically mounted below ground, handling 340,000 gallons of raw sewage per day. The system used one pump to handle the entire flow under normal operation, and used the second pump only in extreme conditions (heavy rainfall). To meet normal loads, each pump rarely operated more than 5 minutes at a time. The control system required two continuously running compressors. A constant pump speed of 1,320 rpm was obtained using a wound rotor and variable resistance circuit motor control system. The pumping system experienced frequent breakdowns, occasional flooding, and sewage spills.

After a thorough systems analysis, engineers installed an additional 10-hp pump with direct on-line motor starters and a passive level control system with float switches, replacing the old active control system. The new pump handles the same volume as the original 40-hp pumps during normal periods, but runs for longer periods of time. The lower outflow rate reduces friction and shock losses in the piping system, which lowers the required head pressure (and thus, the energy consumption).

In addition, the existing pump speed control was eliminated and the motors were wired for direct on-line start. Without the speed control, the motors powering the existing pumps run at 1,750 rpm instead of 1,320 rpm, so their impellers were trimmed to a smaller diameter. The existing pumps are still used for the infrequent peak flows that the new smaller pump cannot handle. Energy consumption was further reduced through the elimination of the two compressors for the active control system and the two circulating pumps for the old motor control system. The installed cost of all the added measures was \$11,000.

Results. In addition to the annual 17,650 kWh of electricity savings from modifying the pump unit, significant energy savings also resulted from changes made to other energy use sources in the station (Figure 7.7.6). Annual energy consumption of the active level control (7,300 kWh/year) and the cooling water pumps (1,750 kWh/year) was entirely eliminated. In all, over 26,000 kWh is being saved annually, a reduction of almost 38%, resulting in \$2,200 in annual energy savings.

This project also produced maintenance savings of \$3,600. Maintenance staff no longer needs to replace two mechanical seals each year. Other benefits of the project savings include extended equipment life due to reduced starting and stopping of the equipment, increased system capacity, and decreased noise. Most of the same measures can be utilized at the town's other pumping stations, as well.

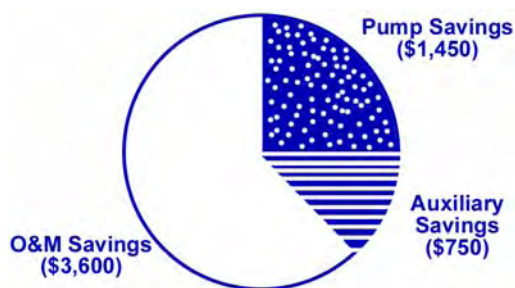

Figure 7.7.6. Pump system energy use and savings.

The total annual savings from the project, due to lower energy costs as well as reduced maintenance and supplies, is \$5,800 (Figure 7.7.7), which is roughly half of the total retrofit cost of \$11,000.

Lessons Learned. Several key conclusions from Trumbull’s experience are relevant for virtually any pumping systems project:

- Proper pump selection and careful attention to equipment operating schedules can yield substantial energy savings.
- In systems with static head, stepping of pump sizes for variable flow rate applications can decrease energy consumption.
- A “systems” approach can identify energy and cost savings opportunities beyond the pumps themselves.

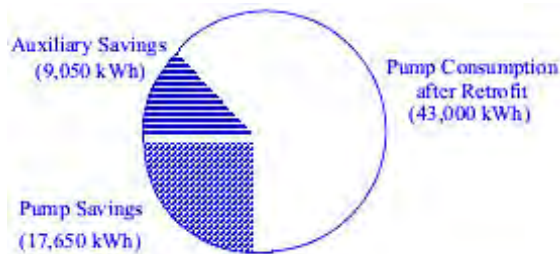

Figure 7.7.7. Retrofit cost savings (\$5,800 annually).

7.7.9 Pumps Checklist

Description	Comments	Maintenance Frequency			
		Daily	Weekly	Monthly	Annually
Pump use/sequencing	Turn off/sequence unnecessary pumps	X			
Overall visual inspection	Complete overall visual inspection to be sure all equipment is operating and safety systems are in place	X			
Check lubrication	Assure that all bearings are lubricated per the manufacture’s recommendation			X	
Check packing	Check packing for wear and repack as necessary. Consider replacing packing with mechanical seals.			X	
Motor/pump alignment	Aligning the pump/motor coupling allows for efficient torque transfer to the pump			X	
Check mountings	Check and secure all pump mountings			X	
Check bearings	Inspect bearings and drive belts for wear. Adjust, repair, or replace as necessary.				X
Motor condition	Checking the condition of the motor through temperature or vibration analysis assures long life				X

7.7.10 References

General Service Administration. 1995. *Public Buildings Maintenance Guides and Time Standards*. Publication 5850, Public Building Service, Office of Real Property Management and Safety.

Viking Pump, Incorporated. May 25, 2001. *Rotary Pump Family Tree*. PumpSchool.com [Online]. Available URL: <http://www.pumpschool.com/intro/pdtree.htm>. Reprinted with permission of Viking Pump, Incorporated.

OIT. 1995. *Modern Industrial Assessments: A Training Manual*. Industrial Assessment Manual from the Office of Productivity and Energy Assessment at the State University of New Jersey, Rutgers, for the U.S. Department of Energy Office of Industrial Technology.

Piotrowski J. April 2, 2001. *Pro-Active Maintenance for Pumps*. Archives, February 2001, Pump-Zone.com [Report online]. Available URL: <http://www.pump-zone.com>. Reprinted with permission of Pump & Systems Magazine.

Pompe Spec Incorporated. July 13, 2001. *Safety Tips*. Resources [Online]. Available URL: http://www.pompespec.com/frameset_e.html?ressources_e.html~bodypompespec. Reprinted with permission of Pompe Spec Incorporated.

Pump World. May 30, 2001a. *Centrifugal*. [Online]. Available URL: <http://www.pumpworld.com/contents.htm>. Reprinted with permission of the Pump World.

Pump World. May 30, 2001b. *Centrifugal Pump Operation: Centrifugal Pump Components*. [Online]. Available URL: <http://www.pumpworld.com/centrif1.htm>. Reprinted with permission of the Pump World.

Pump World. May 30, 2001c. *Positive Displacement Pump Operation: The Basic Operating Principle* [Online]. Available URL: http://www.pumpworld.com/positive_displacement_pump_basic.htm. Reprinted with permission of the Pump World.

Pump World. May 30, 2001d. *Positive* [Online]. Available URL: <http://www.pumpworld.com/positive.htm>. Reprinted with permission of the Pump World.

Pump World. May 30, 2001e. *Positive Displacement Pump Operation: Relief Valves* [Online]. Available URL: http://www.pumpworld.com/positive_displacement_pump_valve.htm. Reprinted with permission of the Pump World.

The Atlanta Cardiology Group. June 29, 2001. *On of the most efficient pumps lies near the center of your chest!* [Online]. Available URL: www.atlcard.com/pump.html.

U.S. Department of Energy (DOE). May 4, 2001. *Case Study: Pump Optimization for Sewage Pumping Station*. Federal Management Energy Program [Online report]. Available URL: http://www.eren.doe.gov/femp/procurement/pump_studies.html.

7.8 Fans

7.8.1 Introduction

The American Society of Heating, Refrigerating, and Air-Conditioning Engineers (ASHRAE) defines a fan as an “air pump that creates a pressure difference and causes airflow. The impeller does the work on the air, imparting to it both static and kinetic energy, varying proportion depending on the fan type” (ASHRAE 1992).

7.8.2 Types of Fans (Bodman and Shelton 1995)

The two general types of fans are axial-flow and centrifugal. With axial-flow fans, the air passes through the fan parallel to the drive shaft. With centrifugal fans, the air makes a right angle turn from the fan inlet to outlet.

7.8.2.1 Axial Fan

Axial-flow fans can be subdivided based on construction and performance characteristics.

- **Propeller fan** – The basic design of propeller fans enhances maintenance to remove dust and dirt accumulations. The fan normally consists of a “flat” frame or housing for mounting, a propeller-shaped blade, and a drive motor. It may be direct drive with the wheel mounted on the motor shaft or belt driven with the wheel mounted on its own shaft and bearings.

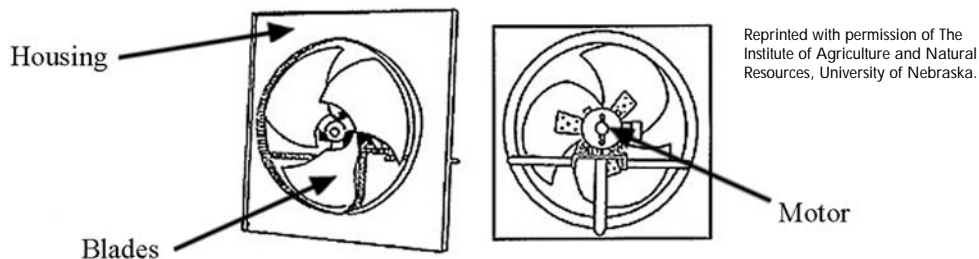

Figure 7.8.1. Propeller direct-drive fan (front and rear view).

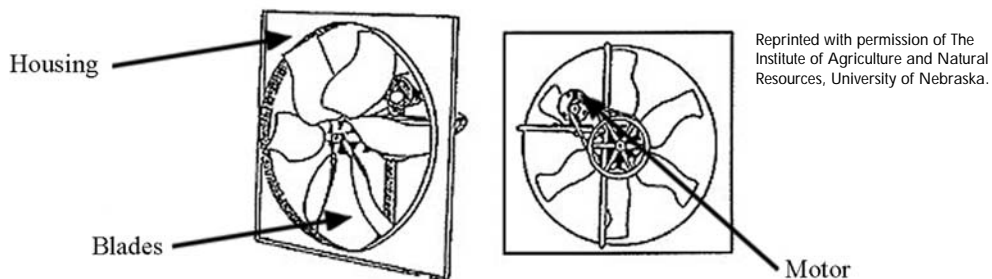

Figure 7.8.2. Propeller belt-drive fan (front and rear view).

- **Tube-axial fans** – A tube-axial fan consists of a tube-shaped housing, a propeller-shaped blade, and a drive motor. Vane-axial fans are a variation of tube-axial fans, and are similar in design and application. The major difference is that air straightening vanes are added either in front of or behind the blades. This results in a slightly more efficient fan, capable of somewhat greater static pressures and airflow rates.

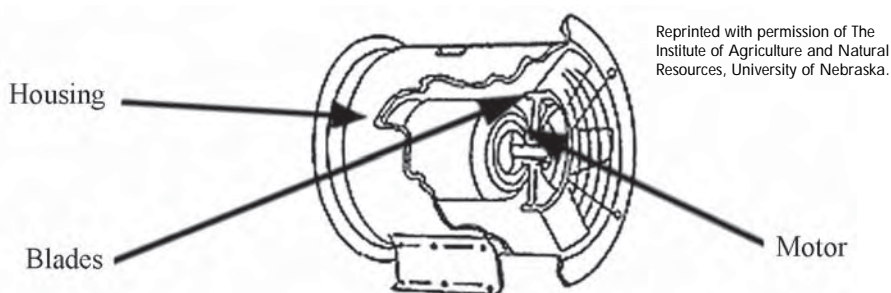

Figure 7.8.3. Tube-axial fan.

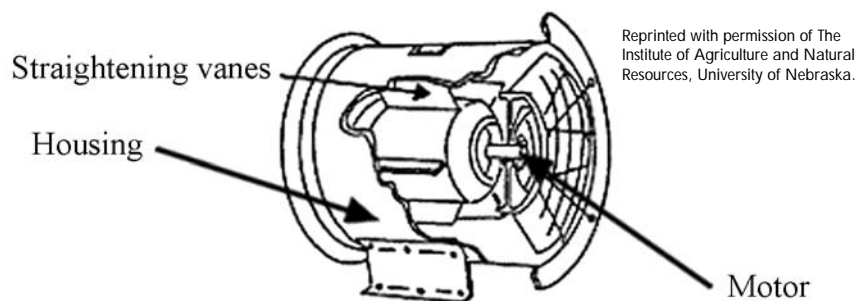

Figure 7.8.4. Vane axial fan.

7.8.2.2 Centrifugal Fans

Often called “squirrel cage” fans, centrifugal fans have an entirely different design (Figure 7.8.5). These fans operate on the principle of “throwing” air away from the blade tips. The blades can be forward curved, straight, or backward curved. Centrifugal fans with backward curved blades are generally more efficient than the other two blade configurations. This design is most often used for aeration applications where high airflow rates and high static pressures are required. Centrifugal fans with forward curved blades have somewhat lower static pressure capabilities but tend to be quieter than the other blade designs. Furnace fans typically use a forward curved blade. An advantage of the straight blade design is that with proper design it can be used to handle dirty air or convey materials.

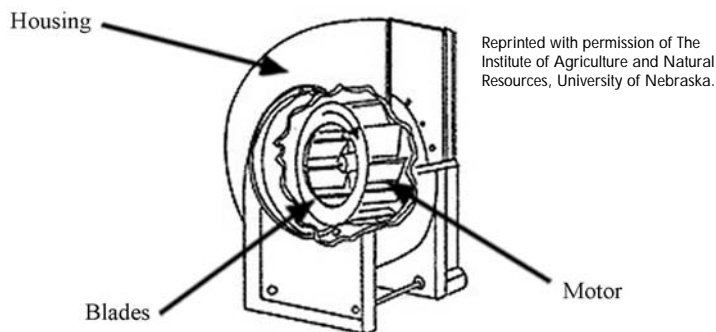

Figure 7.8.5. Centrifugal fan.

7.8.3 Key Components

- **Impeller or rotor** – A series of radial blades are attached to a hub. The assembly of the hub and blades is called impeller or rotor. As the impeller rotates, it creates a pressure difference and causes airflow.
- **Motor** – It drives the blades so they may turn. It may be direct drive with the wheel mounted on the motor shaft or belt driven with the wheel mounted on its own shaft and bearings. It is important to note that fans may also be driven by other sources of motive power such as an internal combustion engine, or steam or gas turbine.
- **Housing** – Encloses and protects the motor and impeller.

7.8.4 Safety Issues

Continuously moving fresh, uncontaminated air through a confined space is the most effective means of controlling an atmospheric hazard. Ventilation dilutes and displaces air contaminants, assures that an adequate oxygen supply is maintained during entry, and exhausts contaminants created by entry activities such as welding, oxygen-fuel cutting, or abrasive blasting (North Carolina State University 2001).

7.8.5 Cost and Energy Efficiency

In certain situations, fans can provide an effective alternative to costly air conditioning. Fans cool people by circulating or ventilating air. Circulating air speeds up the evaporation of perspiration from the skin so we feel cooler. Ventilating replaces hot, stuffy, indoor air with cooler, fresh, outdoor air. Research shows moving air with a fan has the same affect on personal comfort as lowering the temperature by over 5°F. This happens because air movement created by the fan speeds up the rate at which our body loses heat, so we feel cooler. Opening and closing windows or doors helps the fan move indoor air outside and outdoor air inside, increasing the efficiency of the fan. When it is hot outside, close windows and doors to the outside. In the morning or evening, when outdoor air is cooler, place the fan in front of a window or door and open windows on the opposite side of the room. This draws cooler air through the living area (EPCOR 2001).

In many applications, fan control represents a significant opportunity for increased efficiency and reduced cost. A simple and low-cost means of flow control relies on dampers, either before or after the fan. Dampers add resistance to accomplish reduced flow, while increasing pressure. This increased pressure results in increased energy use for the flow level required. Alternatives to damper flow control methods include physical reductions in fan speed though the use of belts and pulleys or variable speed controllers.

7.8.6 Maintenance of Fans

Typically, fans provide years of trouble-free operation with relatively minimal maintenance. However, this high reliability can lead to a false sense of security resulting in maintenance neglect and eventual failure. Due to their prominence within HVAC and other process systems (without the fan operating, the system shuts down), fans need to remain high on the maintenance activity list.

Most fan maintenance activities center on cleaning housings and fan blades, lubricating and checking seals, adjusting belts, checking bearings and structural members, and tracking vibration.

7.8.7 Diagnostic Tools

- **Ultrasonic analyzer** – Air moving systems emit very distinct sound patterns around bearings and fan blades. In most cases, these sounds are not audible to the unaided ear or are drown-out by other equipment noises. Using an ultrasonic detector, the analyst is able to isolate the frequency of sound being emitted by the bearing or blades. Changes in these ultrasonic wave emissions are indicative of changes in equipment condition-some of these changes can be a precursor to component degradation and failure. More information on ultrasonic analysis can be found in Chapter 6.
- **Vibration analyzer** – Within air moving systems, there are many moving parts, most in rotational motion. These parts generate a distinct pattern and level of vibration. Using a vibration analyzer and signature analysis software, the analyst can discern the vibration amplitude of the point on the equipment being monitored. This amplitude is then compared with trended readings. Changes in these readings are indicative of changes in equipment condition. More information on vibration analysis can be found in Chapter 6.

7.8.8 Case Studies

Blower for an Industrial Application

The operation of a centrifugal fan by damper control is energy inefficient as part of the energy supplied to the fan is lost across damper. The damper control has to be minimized by suitably optimizing the capacity of the fan to suit the requirement. One of the best methods to optimize the capacity of the fan is by reducing the RPM of the fan and operate the blower with more damper opening.

Previous Status. An air blower was operated with 30% damper opening. The blower was belt driven. The pressure required for the process was 0.0853 psi. The pressure rise of the blower was 0.1423 psi and the pressure drop across the damper was 0.0569 psi. This indicates an excess capacity/static head available in the blower.

Energy Saving Project. The RPM of the blower was reduced by 20% by suitably changing the pulley. After the reduction in RPM, the damper was operated with 60% to 70% opening.

The replacement of the pulley was taken up during a non-working day. No difficulties were encountered on implementation of the project.

Financial Analysis. The reduction in RPM of the blower and minimizing the damper control resulted in reduction of power consumption by 1.2 kW. The implementation of this project resulted in an annual savings of approximately \$720. The investment made was approximately \$210, which was paid back in under 4 months (Confederation of Indian Industry 2001).

7.8.9 Fans Checklist

Description	Comments	Maintenance Frequency			
		Daily	Weekly	Monthly	Annually
System use/sequencing	Turn off/sequence unnecessary equipment	X			
Overall visual inspection	Complete overall visual inspection to be sure all equipment is operating and safety systems are in place	X			
Observe belts	Verify proper belt tension and alignment			X	
Inspect pulley wheels	Clean and lubricate where required			X	
Inspect dampers	Confirm proper and complete closure control; outside air dampers should be airtight when closed			X	
Observe actuator/linkage control	Verify operation, clean, lubricate, adjust as needed			X	
Check fan blades	Validate proper rotation and clean when necessary			X	
Filters	Check for gaps, replace when dirty - monthly			X	
Check for air quality anomalies	Inspect for moisture/growth on walls, ceilings, carpets, and in/outside of ductwork. Check for musty smells and listen to complaints.			X	
Check wiring	Verify all electrical connections are tight				X
Inspect ductwork	Check and refasten loose connections, repair all leaks				X
Coils	Confirm that filters have kept clean, clean as necessary				X
Insulation	Inspect, repair, replace all compromised duct insulation				X

7.8.10 References

American Society of Heating, Refrigerating, and Air-Conditioning Engineers (ASHRAE). 1992. *ASHRAE HVAC Systems and Equipment*, I-P ed, ASHRAE Handbook, Atlanta, Georgia.

Bodman G.R. and D.P. Shelton. July 2, 2001. *Ventilation Fans: Types and Sizes*. Institute of Agriculture and Natural Resources, University of Nebraska Cooperative Extension, University of Nebraska, May 1995 [Online report]. Available URL: <http://www.ianr.unl.edu/pubs/farmbuildings/g1243.htm>. Reprinted with permission of the Institute of Agriculture and Natural Resources, University of Nebraska.

Confederation of Indian Industry. August 2, 2001. *Reduction of Gasifier Air Blower Speed*. Energy Efficiency, Green Business Centre [Online report]. Available URL: <http://www.energyefficiency-cii.com/glastu.html#2>. Reprinted with permission of the Confederation of Indian Industry.

EPCOR. August 17, 2001. *Cooling with Fans* [Online]. Available URL: <http://www.epcor-group.com/Residential/Efficiency.htm>. Reprinted with permission of EPCOR.

General Service Administration. 1995. *Public Buildings Maintenance Guides and Time Standards*. Publication 5850, Public Building Service, Office of Real Property Management and Safety.

North Carolina State University. August 16, 2001. *Confined Space Ventilation*. Appendix D, Health & Safety Manual, Environmental Health & Safety Center [Online report]. Available URL: <http://www2.ncsu.edu/ncsu/ehs/www99/right/handsMan/confined/Appx-D.pdf>. Reprinted with permission of North Carolina State University.

7.9 Motors

7.9.1 Introduction

Motor systems consume about 70% of all the electric energy used in the manufacturing sector of the United States. To date, most public and private programs to improve motor system energy efficiency have focused on the motor component. This is primarily due to the complexity associated with motor-driven equipment and the system as a whole. The electric motor itself, however, is only the core component of a much broader system of electrical and mechanical equipment that provides a service (e.g., refrigeration, compression, or fluid movement).

MotorMaster+ Software

An energy-efficient motor selection and management tool, MotorMaster+ 3.0 software includes a catalog of over 20,000 AC motors. Version 3.0 features motor inventory management tools, maintenance log tracking, efficiency analysis, savings evaluation, energy accounting, and environmental reporting capabilities.

Available from:

U.S. Department of Energy
Energy Efficiency and Renewable Energy Network
(800) 363-3732
www.oit.doe.gov/bestpractices/motors/.

Numerous studies have shown that opportunities for efficiency improvement and performance optimization are actually much greater in the other components of the system—the controller, the mechanical system coupling, the driven equipment, and the interaction with the process operation. Despite these significant system-level opportunities, most efficiency improvement activities or programs have focused on the motor component or other individual components (Nadel et al. 2001).

7.9.2 Types of Motors

7.9.2.1 DC Motors

Direct-current (DC) motors are often used in variable speed applications. The DC motor can be designed to run at any speed within the limits imposed by centrifugal forces and commutation considerations. Many machine tools also use DC motors because of the ease with which speed can be adjusted.

All DC motors, other than the relatively small brushless types, use a

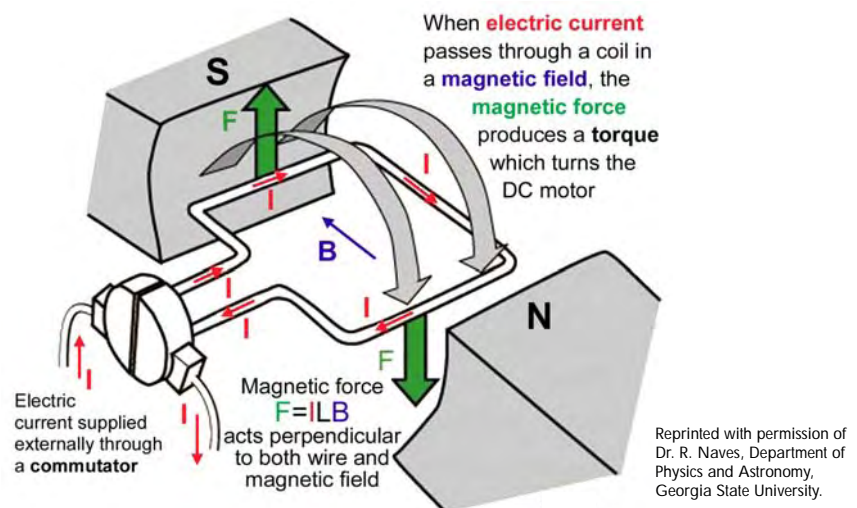

Figure 7.9.1. DC motor.

commutator assembly on the rotor. This requires periodic maintenance and is partly responsible for the added cost of a DC motor when compared to an alternate-current (AC) squirrel-cage induction motor of the same power. The speed adjustment flexibility often justifies the extra cost (Apogee Interactive 2001a).

7.9.2.2 AC Motors (Naves 2001b)

As in the DC motor case, an AC motor has a current passed through the coil, generating a torque on the coil. The design of an AC motor is considerably more involved than the design of a DC motor. The magnetic field is produced by an electromagnet powered by the same AC voltage as the motor coil. The coils that produce the magnetic field are traditionally called the “field coils” while the coils and the solid core that rotates is called the “armature.”

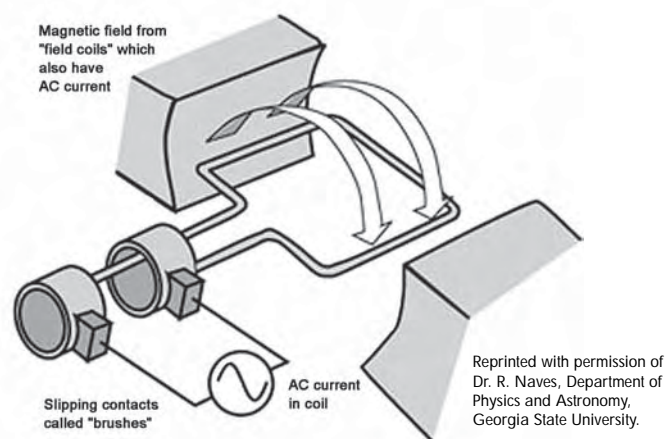

Figure 7.9.2. AC motor.

- Induction motor (VPISU 2001) – The induction motor is a three-phase AC motor and is the most widely used machine. Its characteristic features are:
 - Simple and rugged construction.
 - Low cost and minimum maintenance.
 - High reliability and sufficiently high efficiency.
 - Needs no extra starting motor and need not be synchronized.

An induction motor operates on the principle of induction. The rotor receives power due to induction from stator rather than direct conduction of electrical power. When a three-phase voltage is applied to the stator winding, a rotating magnetic field of constant magnitude is produced. This rotating field is produced by the contributions of space-displaced phase windings carrying appropriate time displaced currents. The rotating field induces an electromotive force (emf).

- Synchronous motor (Apogee Interactive 2001b) – The most obvious characteristic of a synchronous motor is its strict synchronism with the power line frequency. The reason the industrial user is likely to prefer a synchronous motor is its higher efficiency and the opportunity for the user to adjust the motor’s power factor.

A specially designed motor controller performs these operations in the proper sequence and at the proper times during the starting process.

7.9.3 Key Components

7.9.3.1 DC Motor (The World Book Encyclopedia 1986)

- **Field pole** – The purpose of this component is to create a steady magnetic field in the motor. For the case of a small DC motor, a permanent magnet, field magnet, composes the field structure. However, for larger or more complex motors, one or more electromagnets, which receive electricity from an outside power source, is/are the field structure.
- **Armature** – When current goes through the armature, it becomes an electromagnet. The armature, cylindrical in shape, is linked to a drive shaft in order to drive the load. For the case of a small DC motor, the armature rotates in the magnetic field established by the poles, until the north and south poles of the magnets change location with respect to the armature. Once this happens, the current is reversed to switch the south and north poles of the armature.
- **Commutator** – This component is found mainly in DC motors. Its purpose is to overturn the direction of the electric current in the armature. The commutator also aids in the transmission of current between the armature and the power source.

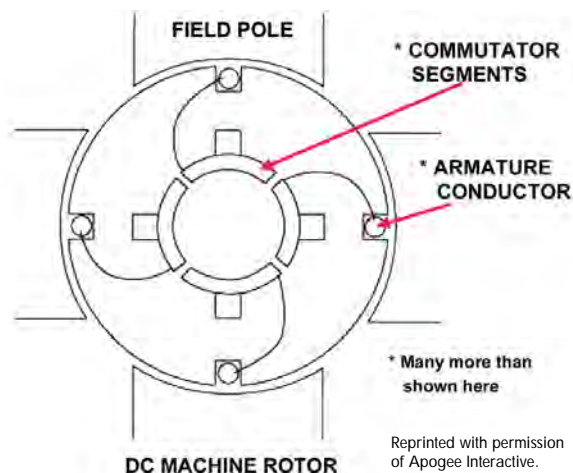

Figure 7.9.3. Parts of a direct current motor.

7.9.3.2 AC Motor

- Rotor
 - Induction motor (VPISU 2001) – Two types of rotors are used in induction motors: squirrel-cage rotor and wound rotor.

A squirrel-cage rotor consists of thick conducting bars embedded in parallel slots. These bars are short-circuited at both ends by means of short-circuiting rings. A wound rotor has three-phase, double-layer, distributed winding. It is wound for as many poles as the stator. The three phases are wye internally and the other ends are connected to slip-rings mounted on a shaft with brushes resting on them.
 - Synchronous motor – The main difference between the synchronous motor and the induction motor is that the rotor of the synchronous motor travels

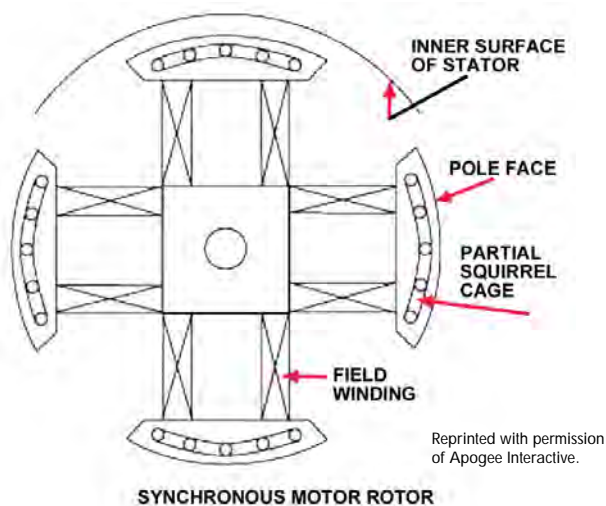

Figure 7.9.4. Parts of an alternating current motor.

at the same speed as the rotating magnetic field. This is possible because the magnetic field of the rotor is no longer induced. The rotor either has permanent magnets or DC-excited currents, which are forced to lock into a certain position when confronted with another magnetic field.

- Stator (VPISU 2001)
 - Induction motor – The stator is made up of a number of stampings with slots to carry three-phase windings. It is wound for a definite number of poles. The windings are geometrically spaced 120 degrees apart.
 - Synchronous motor – The stator produces a rotating magnetic field that is proportional to the frequency supplied.

7.9.4 Safety Issues (Operators and Consulting Services Incorporated 2001)

Electric motors are a major driving force in many industries. Their compact size and versatile application potentials make them a necessity. Motors are chosen many times because of the low vibration characteristics in driving equipment because of the potential extended life of the driven equipment. The higher rpm and small size of a motor will also make it a perfect fit for many applications.

Motors can be purchased for varying application areas such as for operating in a potentially gaseous or explosive area. When purchasing a motor, be sure to check the classification of the area, you may have a motor that does not meet the classification it is presently in! For example, a relatively new line of motors is being manufactured with special external coatings that resist the elements. These were developed because of the chemical plant setting in which highly corrosive atmospheres were deteriorating steel housings. They are, for the most part, the same motors but have an epoxy or equivalent coating.

7.9.5 Cost and Energy Efficiency (DOE 2001a)

An electric motor performs efficiently only when it is maintained and used properly. Electric motor efficiencies vary with motor load; the efficiency of a constant speed motor decreases as motor load decreases. Below are some general guidelines for efficient operations of electric motors.

- Turn off unneeded motors – Locate motors that operate needlessly, even for a portion of the time they are on and turn them off. For example, there may be multiple HVAC circulation pumps operating when demand falls, cooling tower fans operating when target temperatures are met, ceiling fans on in unoccupied spaces, exhaust fans operating after ventilation needs are met, and escalators operating after closing.
- Reduce motor system usage – The efficiency of mechanical systems affects the run-time of motors. For example, reducing solar load on a building will reduce the amount of time the air handler motors would need to operate.
- Sizing motors is important – Do not assume an existing motor is properly sized for its load, especially when replacing motors. Many motors operate most efficiently at 75% to 85% of full load rating. Under-sizing or over-sizing reduces efficiency. For large motors, facility managers may

want to seek professional help in determining the proper sizes and actual loadings of existing motors. There are several ways to estimate actual motor loading: the kilowatt technique, the amperage ratio technique, and the less reliable slip technique. All three are supported in the Motor Master Plus software.

- Replacement of motors versus rewinding – Instead of rewinding small motors, consider replacement with an energy-efficient version. For larger motors, if motor rewinding offers the lowest life-cycle cost, select a rewind facility with high quality standards to ensure that motor efficiency is not adversely affected. For sizes of 10 hp or less, new motors are generally cheaper than rewinding. Most standard efficiency motors under 100 hp will be cost-effective to scrap when they fail, provided they have sufficient run-time and are replaced with energy-efficient models.

Strategies to Reduce Motor System Usage

- Reduce loads on HVAC systems.
 - Improve building shell.
 - Manage restorations better.
 - Improve HVAC conditions.
 - Check refrigerant charge.
- Reduce refrigeration loads.
 - Improve insulation.
 - Add strip curtains on doors.
 - Calibrate control setpoints.
 - Check refrigerant charge.
- Check ventilation systems for excessive air.
 - Re-sheave fan if air is excessive.
 - Downsize motors, if possible.
- Improve compressed air systems.
 - Locate and repair compressed air leaks.
 - Check air tool fittings for physical damage.
 - Turn off air to tools when not in use.
- Repair duct leaks.

7.9.6 Maintenance of Motors

Preventative and predictive maintenance programs for motors are effective practices in manufacturing plants. These maintenance procedures involve a sequence of steps plant personnel use to prolong motor life or foresee a motor failure. The technicians use a series of diagnostics such as motor temperature and motor vibration as key pieces of information in learning about the motors. One way a technician can use these diagnostics is to compare the vibration signature found in the motor with the failure mode to determine the cause of the failure. Often failures occur well before the expected design life span of the motor and studies have shown that mechanical failures are the prime cause of premature electrical failures. Preventative maintenance takes steps to improve motor performance and to extend its life. Common preventative tasks include routine lubrication, allowing adequate ventilation, and ensuring the motor is not undergoing any type of unbalanced voltage situation.

The goal of predictive maintenance programs is to reduce maintenance costs by detecting problems early, which allows for better maintenance planning and less unexpected failures. Predictive maintenance programs for motors observe the temperatures, vibrations, and other data to determine a time for an overhaul or replacement of the motor (Barnish et al. 2001).

Consult each motor's instructions for maintenance guidelines. Motors are not all the same. Be careful not to think that what is good for one is good for all. For example, some motors require a periodic greasing of the bearings and some do not (Operators and Consulting Services Incorporated 2001).

General Requirements for Safe and Efficiency Motor Operation (DOE 2001a)

1. Motors, properly selected and installed, are capable of operating for many years with a reasonably small amount of maintenance.
2. Before servicing a motor and motor-operated equipment, disconnect the power supply from motors and accessories. Use safe working practices during servicing of the equipment.
3. Clean motor surfaces and ventilation openings periodically, preferably with a vacuum cleaner. Heavy accumulations of dust and lint will result in overheating and premature motor failure.
4. Facility managers should inventory all motors in their facilities, beginning with the largest and those with the longest run-times. This inventory enables facility managers to make informed choices about replacement either before or after motor failure. Field testing motors prior to failure enables the facility manager to properly size replacements to match the actual driven load. The software mentioned below can help with this inventory.

7.9.7 Diagnostic Tools

- **Thermography** – An infrared thermometer or camera allows for an accurate, non-contact assessment of temperature. Applications for motors include bearing and electrical contact assessments on motor systems and motor control centers. More information on thermography can be found in Chapter 6.
- **Ultrasonic analyzer** – Electric motor systems emit very distinct sound patterns around bearings. In most cases, these sounds are not audible to the unaided ear or are drown-out by other equipment noises. Using an ultrasonic detector, the analyst is able to isolate the frequency of sound being emitted by the bearing. Changes in these ultrasonic wave emissions are indicative of changes in equipment condition-some of these changes can be a precursor to component degradation and failure. More information on ultrasonic analysis can be found in Chapter 6.
- **Vibration analyzer** – The rotational motion within electric motors generates distinct patterns and levels of vibration. Using a vibration analyzer and signature analysis software, the analyst can discern the vibration amplitude of the point on the motor being monitored. This amplitude is then compared with trended readings. Changes in these readings are indicative of changes in equipment condition. More information on vibration analysis can be found in Chapter 6.
- **Other motor analysis** – Motor faults or conditions including winding short-circuits, open coils, improper torque settings, as well as many mechanical problems can be diagnosed using a variety of motor analysis techniques. These techniques are usually very specialized to specific motor types and expected faults. More information on motor analysis techniques can be found in Chapter 6.

7.9.8 Electric Motors Checklist

Description	Comments	Maintenance Frequency			
		Daily	Weekly	Monthly	Annually
Motor use/sequencing	Turn off/sequence unnecessary motors	X			
Overall visual inspection	Complete overall visual inspection to be sure all equipment is operating and safety systems are in place	X			
Motor condition	Check the condition of the motor through temperature or vibration analysis and compare to baseline values		X		
Check lubrication	Assure that all bearings are lubricated per the manufacture's recommendation			X	
Check packing	Check packing for wear and repack as necessary. Consider replacing packing with mechanical seals.			X	
Motor alignment	Aligning the motor coupling allows for efficient torque transfer to the pump			X	
Check mountings	Check and secure all motor mountings			X	
Check terminal tightness	Tighten connection terminals as necessary			X	
Cleaning	Remove dust and dirt from motor to facilitate cooling			X	
Check bearings	Inspect bearings and drive belts for wear. Adjust, repair, or replace as necessary.				X
Motor condition	Checking the condition of the motor through temperature or vibration analysis assures long life				X
Check for balanced three-phase power	Unbalanced power can shorten the motor life through excessive heat build up				X
Check for over-voltage or under-voltage conditions	Over- or under-voltage situations can shorten the motor life through excessive heat build up				X

7.9.9 References

Apogee Interactive. July 5, 2001a. *Characteristics of Direct Current Motors*. Electrical Systems [Online]. Available URL: <http://oge.apogee.net/pd/dmhc.htm>. Reprinted with permission of Apogee Interactive, www.apogee.net.

Apogee Interactive. July 5, 2001b. *Characteristics of a Synchronous Motor*. Electrical Systems [Online]. Available URL: <http://oge.apogee.net/pd/dmsm.htm>. Reprinted with permission of Apogee Interactive, www.apogee.net.

Barnish T.J., M.R. Muller, and D.J. Kasten. June 14, 2001. *Motor Maintenance: A Survey of Techniques and Results*. Presented at the 1997 ACEEE Summer Study on Energy Efficiency in Industry, July 8-11, 1997, Saratoga Springs, New York, Office of Industrial Productivity and Energy Assessment,

Department of Mechanical and Aerospace Engineering, Rutgers, The State University of New Jersey [Online report]. Available URL: http://oiepa-www.rutgers.edu/documents/papers/aceee1_paper.html. Reprinted with permission of Office of Industrial Productivity and Energy Assessment, Department of Mechanical and Aerospace Engineering, Rutgers, The State University of New Jersey.

Confederation of Indian Industry. July 15, 2001. *Replacement with Correct Size Combustion Air Blower in Kiln*. Case Studies [Online report]. Available URL: <http://www.energyefficiency-cii.com/glastu.html#2>. Reprinted with permission of Confederation of Indian Industry.

Franklin Electric. July 12, 2001. *All Motors*. Page 37, Maintenance, AIM Manual, Technical Service [Online report]. Available URL: http://www.fele.com/Manual/AIM_37.htm. Reprinted with permission of Franklin Electric, www.franklin-electric.com.

General Service Administration. 1995. *Public Buildings Maintenance Guides and Time Standards*. Publication 5850, Public Building Service, Office of Real Property Management and Safety.

Operators and Consulting Services Incorporated. May 30, 2001. *Electric Motors*. Oilfield Machinery Maintenance Online [Online]. Available URL: <http://www.oilmachineryforum.com/electric.htm>. Reprinted with permission of Operators and Consulting Services Incorporated.

Nadel S.R., N. Elliott, M. Shepard, S. Greenberg, G. Katz, and A.T. de Almeida. Forthcoming (2001). *Energy-Efficient Motor Systems: A Handbook on Technology, Program, and Policy Opportunities*. 2nd ed. Washington, D.C. American Council for an Energy-Efficient Economy. Reprinted with permission of American Council for an Energy-Efficient Economy.

Naves R. July 8, 2001. *DC Motor*. Electricity and Magnetism, HyperPhysics, Department of Physics and Astronomy, Georgia State University [Online]. Available URL: <http://hyperphysics.phy-astr.gsu.edu/hbase/magnetic/motdc.html#c1>. Reprinted with permission Dr. R. Naves, Department of Physics and Astronomy, Georgia State University.

Naves R. July 8, 2001. *AC Motor*. Electricity and Magnetism, HyperPhysics, Department of Physics and Astronomy, Georgia State University [Online]. Available URL: <http://hyperphysics.phy-astr.gsu.edu/hbase/magnetic/motorac.html>. Reprinted with permission Dr. R. Naves, Department of Physics and Astronomy, Georgia State University.

The World Book Encyclopedia. 1986. *Motors*. Volume 13, World Book, Inc.

U.S. Department of Energy (DOE). August 12, 2001. *Greening Federal Facilities: An Energy, Environmental, and Economic Resource Guide for Federal Facility Managers and Designers*. 2nd ed., Part V Energy Systems, 5.7 Electric Motors and Drives, Federal Management Energy Program [Online report]. Available URL: <http://www.nrel.gov/docs/fy01osti/29267.pdf>.

U.S. Department of Energy (DOE). July 11, 2001. *Personal Injury in Air Handling Unit*, 1998-CH-AMES-0001, February 4, 1998, Lessons Learned Database, Chicago Operations Office [Online Report]. Available URL: http://tis.eh.doe.gov/ll/lldb/detail.CFM?Lessons__IdentifierIntern=1998Y%2D1998%2DCH%2DAMES%2D0001.

Virginia Polytechnic Institute and State University and Iowa State University. July 14, 2001. *Induction Motor*, Powerlearn Program funded by the National Science Foundations and the Electric Power Research Institute [Online]. Available URL: <http://powerlearn.ece.vt.edu/modules/PE2/index.html>. Reprinted with permission of Virginia Polytechnic Institute and State University.

7.10 Air Compressors

7.10.1 Introduction

Compressed air, along with gas, electricity, and water, is essential to most modern industrial and commercial operations. It runs tools and machinery, provides power for material handling systems, and ensures clean, breathable air in contaminated environments. It is used by virtually every industrial segment from aircraft and automobiles to dairies, fish farming, and textiles.

The Compressed Air Challenge™

The Compressed Air Challenge™ is a national collaborative formed in October 1997 to assemble state-of-the-art information on compressed air system design, performance, and assessment procedures.

Available from: <http://www.knowpressure.org>.

A plant's expense for its compressed air is often thought of only in terms of the cost of the equipment. Energy costs, however, represent as much as 70% of the total expense in producing compressed air. As electricity rates escalate across the nation and the cost of maintenance and repair increases, selecting the most efficient and reliable compressor becomes critical (Kaeser Compressors 2001a).

7.10.2 Types of Air Compressors (Dyer and Maples 1992)

The two general types of air compressors are positive displacement and centrifugal.

7.10.2.1 Positive Displacement

- **Rotary screw compressor** – The main element of the rotary screw compressor is made up of two close clearance helical-lobe rotors that turn in synchronous mesh. As the rotors revolve, the gas is forced into a decreasing inter-lobe cavity until it reaches the discharge port. In lubricated units, the male rotor drives the female and oil is injected into the cylinder serving as a lubricant, coolant, and as an oil seal to reduce back slippage. On non-lubricated types, timing gears are used to drive the rotors and multistaging is necessary to prevent gas temperatures from going too high.

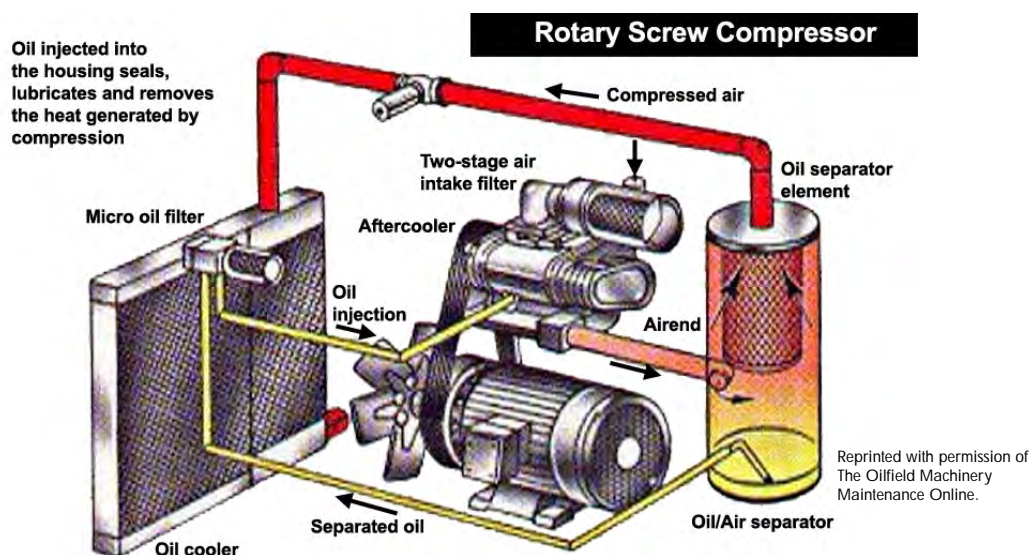

Figure 7.10.1. Rotary screw compressor.

- **Reciprocating compressor** – A reciprocating compressor is made up of a cylinder and a piston. Compression is accomplished by the change in volume as the piston moves toward the “top” end of the cylinder. This compression may be oil-lubricated or, in some cases, it may require little or no lubrication (oil-free) in the cylinder.

The cylinder in the reciprocating machines may be air cooled or water cooled. Water cooling is used on the larger units. This cooling action is very important to increase compressor life and to keep maintenance and repairs low.

Multiple stage compressors have a minimum of two pistons. The first compresses the gas to an intermediate pressure. Intercooling of the gas before entering the second stage usually follows the first stage compression. Two stage units allow for more efficient and cooler operating compressors, which increases compressor life.

7.10.2.2 Centrifugal Compressor

The compression action is accomplished when the gas enters the center of rotation and is accelerated as it flows in an outward direction. This gas velocity is then transferred into a pressure rise. Part of the pressure rise occurs in the rotor and part in a stationary element called the diffuser. The rotating element can have either forward curved blades, radial blades, or backward blades.

The centrifugal compressor will usually have more than one stage of compression with intercooling between each stage. One of the drawbacks of this machine is its inability to deliver part-load flow at overall efficiencies as high as other types of compressors. Many people consider the centrifugal machine a base-load machine.

7.10.3 Key Components (Dyer and Maples 1992)

- Positive Displacement Air Compressor
 - Cylinder – Chamber where the compression process takes place by the change in its volume as the piston moves up and down.
 - Piston – Component located inside the cylinder directly responsible for the compression of air.
 - Crankshaft – Converts rotational motion generated by the motor to unidirectional motion for the piston.
 - Connecting rod – Connects the crankshaft with the piston.
 - Inlet and exhaust valves – Control the amount of air going in and out of the cylinder.

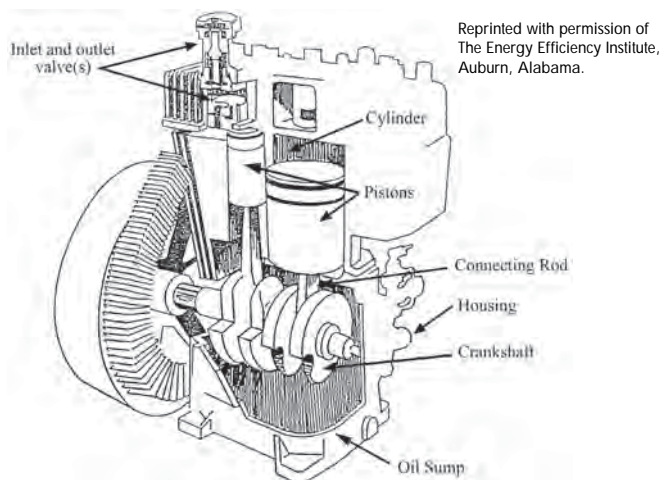

Figure 7.10.2. Typical single acting two-stage compressor.

- Rotary Screw Compressor
 - Helical-lobe rotors – The main elements of this type of compressor where two close clearance helical-lobe rotors turn in synchronous mesh. As the rotors revolve, the gas is forced into a decreasing “inter-lobe cavity until it reaches the discharge port (Figure 7.10.3).
- Centrifugal Compressor
 - Rotating Impeller – Imparts velocity to the air, which is converted to pressure.

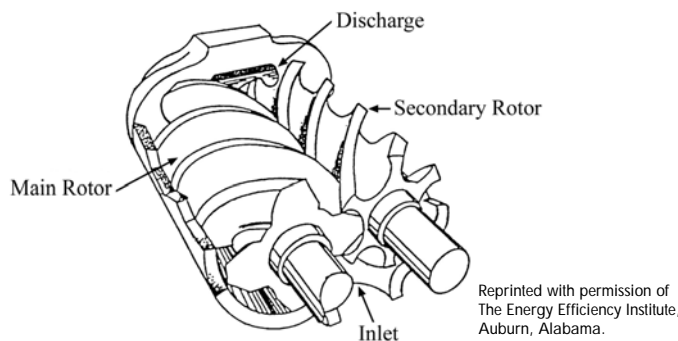

Figure 7.10.3. Helical-lobe rotors.

7.10.4 Safety Issues (UFEHS 2001)

7.10.4.1 General Safety Requirements for Compressed Air

All components of compressed air systems should be inspected regularly by qualified and trained employees. Maintenance superintendents should check with state and/or insurance companies to determine if they require their own inspection of this equipment. Operators need to be aware of the following:

- Air receivers – The maximum allowable working pressures of air receivers should never be exceeded except when being tested. Only hydrostatically tested and approved tanks shall be used as air receivers.
 - Each air receiver shall be equipped with at least one pressure gauge and an ASME safety valve of the proper design.
 - A safety (spring loaded) release valve shall be installed to prevent the receiver from exceeding the maximum allowable working pressure.
- Air distribution lines
 - Air lines should be made of high quality materials, fitted with secure connections.
 - Hoses should be checked to make sure they are properly connected to pipe outlets before use.
 - Air lines should be inspected frequently for defects and any defective equipment repaired or replaced immediately.
 - Compressed air lines should be identified as to maximum working pressures (psi) by tagging or marking pipeline outlets.

- Pressure regulation devices
 - Valves, gauges, and other regulating devices should be installed on compressor equipment in such a way that cannot be made inoperative.
 - Air tank safety valves should be set no less than 15 psi or 10% (whichever is greater) above the operating pressure of the compressor but never higher than the maximum allowable working pressure of the air receiver.
- Air compressor operation
 - Air compressor equipment should be operated only by authorized and trained personnel.
 - The air intake should be from a clean, outside, fresh air source. Screens or filters can be used to clean the air.
 - Air compressors should never be operated at speeds faster than the manufacturers recommendation.
 - Moving parts, such as compressor flywheels, pulleys, and belts that could be hazardous should be effectively guarded.

7.10.5 Cost and Energy Efficiency (Kaeser Compressors 2001b)

It takes 7 to 8 hp of electricity to produce 1 hp worth of air force. Yet, this high-energy cost quite often is overlooked. Depending on plant location and local power costs, the annual cost of electrical power can be equal to-or as much as two times greater than-the initial cost of the air compressor. Over a 10-year operating period, a 100-hp compressed air system that you bought for \$40,000 will accumulate up to \$800,000 in electrical power costs. Following a few simple steps can significantly reduce energy costs by as much as 35%.

7.10.5.1 Identify the Electrical Cost of Compressed Air

To judge the magnitude of the opportunities that exist to save electrical power costs in your compressed air system, it is important to identify the electrical cost of compressed air. Chart 1 shows the relationship between compressor hp and energy cost. In addition, consider the following:

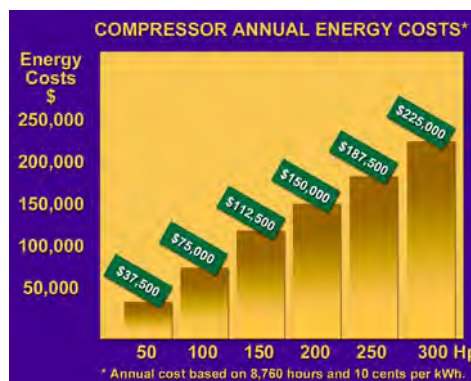

Reprinted with permission of Kaeser Compressors, Inc., Fredericksburg, Virginia.

Chart 1

- Direct cost of pressure – Every 10 psig increase of pressure in a plant system requires about 5% more power to produce. For example: A 520 cubic-foot-per-minute (cfm) compressor, delivering air at 110 pounds per-square-inch-gage (psig), requires about 100 horsepower (hp). However, at 100 psig, only 95 hp is required. Potential power cost savings (at 10 cents per kWh; 8,760 hr/year) is \$3,750/year.
- Indirect cost of pressure – System pressure affects air consumption on the use or demand side. The air system will automatically use more air at higher pressures. If there is no resulting increase in

productivity, air is wasted. Increased air consumption caused by higher than needed pressure is called *artificial demand*. A system using 520 cfm at 110 psig inlet pressure will consume only 400 cfm at 80 psig. The potential power cost savings (520 cfm - 400 cfm = 120 cfm, resulting in 24 hp, at 10 cents/kWh; 8,760 hr/year) is \$18,000/year. Note: Also remember that the leakage rate is significantly reduced at lower pressures, further reducing power costs.

- The cost of wasted air volume – Each cubic feet per meter of air volume wasted can be translated into extra compressor horsepower and is an identifiable cost. As shown by Chart 1, if this waste is recovered, the result will be \$750/hp per year in lower energy costs.
- Select the most efficient demand side – The magnitude of the above is solely dependent on the ability of the compressor control to translate reduced air flow into lower electrical power consumption.

Chart 2 shows the relationship between the full load power required for a compressor at various air demands and common control types. It becomes apparent that the on line-off line control (dual control) is superior to other controls in translating savings in air consumption into real power savings. Looking at our example of reducing air consumption from 520 cfm to 400 cfm (77%), the compressor operating on dual control requires 83% of full load power. That is 12% less energy than when operated on modulation control. If the air consumption drops to 50%, the difference (dual versus modulation) in energy consumption is increased even further, to 24%.

7.10.5.2 Waste Heat Recovered from Compressors can be Used for Heating (Kaeser Compressors 2001c)

The heat generated by air compressors can be used effectively within a plant for space heating and/or process water heating. Considerable energy savings result in short payback periods.

- Process heating – Heated water is available from units equipped with water-cooled oil coolers and after-coolers. Generally, these units can effectively discharge the water at temperatures between 130°F and 160°F.
- Space heating – Is essentially accomplished by ducting the heated cooling air from the compressor package to an area that requires heating. If ductwork is used, be careful not

General Notes on Air Compressors (OIT 1995)

- Screw air compressors use 40% to 100% of rated power unloaded.
- Reciprocating air compressors are more efficient, but also more expensive.
- About 90% of energy becomes heat.
- Rule of thumb: roughly 20 hp per 100 cfm at 100 psi.
- Use low-pressure blowers versus compressed air whenever possible.
- Second, third, weekend shifts may have low compressed air needs that could be served by a smaller compressor.
- Outside air is cooler, denser, easier to compress than warm inside air.
- Friction can be reduced by using synthetic lubricants.
- Older compressors are driven by older less efficient motors.

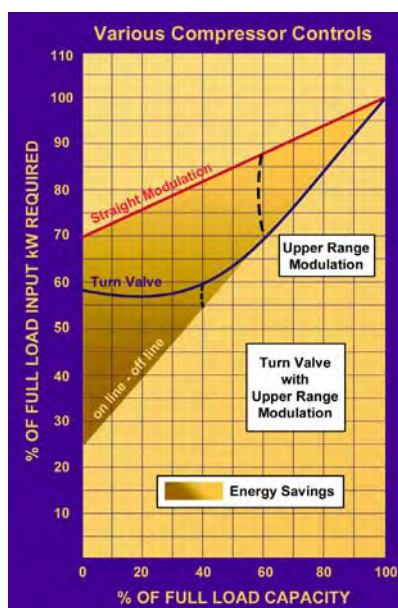

Chart 2

Reprinted with permission of Kaeser Compressors, Inc., Fredericksburg, Virginia.

to exceed the manufacturer's maximum back-pressure allowance. When space heating is used in the winter, arrangements should be made in the ductwork to return some of the heated air to the compressor room in order to maintain a 60°F room temperature. This ensures that the air discharged is at comfortable levels.

7.10.5.3 Use of Flow Controllers

Most compressed air systems operate at artificially high pressures to compensate for flow fluctuations and downstream pressure drops caused by lack of “real” storage and improperly designed piping systems. Even if additional compressor capacity is available, the time delay caused by bringing the necessary compressor(s) on-line would cause unacceptable pressure drop.

Operating at these artificially high pressures requires up to 25% more compressor capacity than actually needed. This 25% in wasted operating cost can be eliminated by reduced leakage and elimination of artificial demand.

A flow controller separates the supply side (compressors, dryers, and filters) from the demand side (distribution system). It creates “real” storage within the receiver tank(s) by accumulating compressed air without delivering it downstream. The air pressure only increases upstream of the air receiver, while the flow controller delivers the needed flow downstream at a constant, lower system pressure. This reduces the actual flow demand by virtually eliminating artificial demand and substantially reducing leakage.

7.10.5.4 Importance of Maintenance to Energy Savings

- Leaks are expensive. Statistics show that the average system wastes between 25% and 35% to leaks. In a compressed air system of 1,000 cfm, 30% leaks equals 300 cfm. That translates into savings of 60 hp or \$45,000 annually.
- A formalized program of leak monitoring and repair is essential to control costs. As a start, monitor all the flow needed during off periods.
- Equip maintenance personnel with proper leak detection equipment and train them on how to use it. Establish a routine for regular leak inspections. Involve both maintenance and production personnel.
- Establish accountability of air usage as part of the production expense. Use flow controllers and sequencers to reduce system pressure and compressed air consumption.
- A well-maintained compressor not only serves you better with less downtime and repairs, but will save you electrical power costs too.

7.10.6 Maintenance of Air Compressors (Oil Machinery Maintenance Online 2001)

Maintenance of your compressed air system is of great importance and is often left undone or half done. Neglect of an air system will ultimately “poison” the entire downstream air system and cause headaches untold. Clean dry air supplies start at the air compressor package. The small amount of time you spend maintaining the system is well worth the trouble.

7.10.6.1 General Requirements for a Safe and Efficient Air Compressor

- Always turn power off before servicing.
- Compressor oil and oil cleanliness:
 - Change the oil according to manufacturer's recommendations.
 - Use a high-quality oil and keep the level where it's supposed to be.
 - Sample the oil every month.
- Condensate control
 - Drain fluid traps regularly or automatically.
 - Drain receiving tanks regularly or automatically.
 - Service air-drying systems according to manufacturer's recommendations.
- Keep air inlet filters clean.
- Keep motor belts tight.
- Minimize system leaks.

Common Causes of Air Compressor Poor Performance (Kaeser Compressors 2001d)		
<u>Problem</u>	<u>Probable Cause</u>	<u>Remedial Action</u>
Low pressure at point of use	Leaks in distribution piping	Check lines, connections, and valves for leaks; clean or replace filter elements
	Clogged filter elements	
	Fouled dryer heat exchanger	Clean heat exchanger
	Low pressure at compressor discharge	
Low pressure at compressor discharge	For systems with modulating load controls, improper adjustment of air capacity control	Follow manufacturer's recommendation for adjustment of control
	Worn or broken valves	Check valves and repair or replace as required
	Improper air pressure switch setting	Follow manufacturer's recommendations for setting air pressure switch
Water in lines	Failed condensate traps	Clean, repair, or replace the trap
	Failed or undersized compressed air dryer	Repair or replace dryer
Liquid oil in air lines	Faulty air/oil separation	Check air/oil separation system; change separator element
Dirt, rust, or scale in air lines	In the absence of liquid water, normal aging of the air lines	Install filters at point of use

Common Causes of Air Compressor Poor Performance (Kaeser Compressors 2001d) (contd)		
<u>Problem</u>	<u>Probable Cause</u>	<u>Remedial Action</u>
Excessive service to load/hour ratio	System idling too much	For multiple compressor systems, consider sequencing controls to minimize compressor idle time; adjust idle time according to manufacturer's recommendations
	Improper pressure switch setting	Readjust according to manufacturer's recommendations
Elevated compressor temperature	Restricted air flow	Clean cooler exterior and check inlet filter mats
	Restricted water flow	Check water flow, pressure, and quality; clean heat exchanger as needed
	Low oil level	Check compressor oil level; add oil as required
	Restricted oil flow	Remove restriction; replace parts as required
	Excessive ambient temperatures	Improper ventilation to compressor; check with manufacturer to determine maximum operating temperature

7.10.7 Diagnostic Tools

- **Ultrasonic analyzer** – Compressed gas systems emit very distinct sound patterns around leakage areas. In most cases, these sounds are not audible to the unaided ear or are drown-out by other equipment noises. Using an ultrasonic detector, the analyst is able to isolate the frequency of sound being emitted by the air or gas leak. The ultrasonic detector represents an accurate and cost effective means to locate leaks in air/gas systems. More information on ultrasonic analysis can be found in Chapter 6.
- **Vibration analyzer** – Within a compressor, there are many moving parts; some in rotational motion and some in linear motion. In either case, these parts generate a distinct pattern and level of vibration. Using a vibration analyzer and signature analysis software, the analyst can discern the vibration amplitude of the point on the equipment being monitored. This amplitude is then compared with trended readings. Changes in these readings are indicative of changes in equipment condition. More information on vibration analysis can be found in Chapter 6.

7.10.8 Case Study

Air Compressor Leakage (OIT 1995)

The cost of compressed air leaks is the energy cost to compress the volume of the lost air from atmospheric pressure to the compressor operating pressure. The amount of lost air depends on the line pressure, the compressed air temperature and the point of the leak, the air temperature at the compressor inlet, and the estimated area of the leak.

A study of a 75-hp compressor that operates 8,520 hours per year was shown to have a leakage rate of 24%. The majority of these leaks were due to open, unused lines. The compressor, a single-stage screw type, provides compressed air at 115 psi, is 91.5% efficient, and operates with electricity costing \$14.05 per million Btu.

The study identified eight major leaks ranging in size from 1/16 to 1/8 inches in diameter. The calculated total annual cost of these leaks was \$5,730.

Correcting the leaks in this system involved the following:

- Replacement of couplings and/r hoses.
- Replacement of seals around filters.
- Repairing breaks in compressed-air lines.

The total cost of the repairs was \$460. Thus, the cost savings of \$5,730 would pay for the implementation cost of \$460 in about a month.

7.10.9 Air Compressors Checklist

Description	Comments	Maintenance Frequency			
		Daily	Weekly	Monthly	Annually
Compressor use/sequencing	Turn off/sequence unnecessary compressors	X			
Overall visual inspection	Complete overall visual inspection to be sure all equipment is operating and safety systems are in place	X			
Leakage assessment	Look for and report any system leakages	X			
Compressor operation	Monitor operation for run time and temperature variance from trended norms	X			
Dryers	Dryers should be observed for proper function	X			
Compressor ventilation	Make sure proper ventilation is available for compressor and inlet	X			
Compressor lubricant	Note level, color, and pressure. Compare with trended values.	X			
Condensate drain	Drain condensate from tank, legs, and/or traps	X			
Operating temperature	Verify operating temperature is per manufacturer specification	X			
Pressure relief valves	Verify all pressure relief valves are functioning properly		X		
Check belt tension	Check belt tension and alignment for proper settings		X		
Intake filter pads	Clean or replace intake filter pads as necessary		X		

Air Compressors Checklist (contd)

Description	Comments	Maintenance Frequency			
		Daily	Weekly	Monthly	Annually
Air-consuming device check	All air-consuming devices need to be inspected on a regular basis for leakage. Leakage typically occurs in: <ul style="list-style-type: none"> • Worn/cracked/frayed hoses • Sticking air valves • Cylinder packing 		X		
Drain traps	Clean out debris and check operation		X		
Motor bearings	Lubricate motor bearings to manufacturer's specification			X	
System oil	Depending on use and compressor size, develop periodic oil sampling to monitor moisture, particulate levels, and other contamination. Replace oil as required.			X	
Couplings	Inspect all couplings for proper function and alignment				X
Shaft seals	Check all seals for leakage or wear				X
Air line filters	Replace particulate and lubricant removal elements when pressure drop exceeds 2-3 psid				X
Check mountings	Check and secure all compressor mountings				X

7.10.10 References

Dyer D.F. and G. Maples. 1992. *Electrical Efficiency Improvement*. Energy Efficiency Institute, Auburn.

Kaeser Compressors, Inc. July 29, 2001a. *Getting the Most for Your Money: Types of Compressors*. Air Compressor Guide [Online Report]. Available URL: <http://www.maintenanceresources.com/ReferenceLibrary/AirCompressors/kaeserpage1.htm>.

Kaeser Compressors, Inc. July 29, 2001b. *Evaluating Compressor Efficiency*. Air Compressor Guide [Online Report]. Available URL: <http://www.maintenanceresources.com/ReferenceLibrary/AirCompressors/kaeserpage7.htm>.

Kaeser Compressors, Inc. July 29, 2001c. *Waste Heat Recovery and the Importance of Maintenance*. Air Compressor Guide [Online Report]. Available URL: <http://www.maintenanceresources.com/ReferenceLibrary/AirCompressors/kaeserpage9.htm>.

Kaeser Compressors, Inc. July 29, 2001d. *Getting the Most for Your Money: Troubleshooting*. Air Compressor Guide [Online Report]. Available URL: <http://www.maintenanceresources.com/ReferenceLibrary/AirCompressors/kaeserpage5.htm>.

OIT. 1995. *Modern Industrial Assessments: A Training Manual*. Industrial Assessment Manual from the Office of Productivity and Energy Assessment at the State University of New Jersey, Rutgers, for the U.S. Department of Energy Office of Industrial Technology.

Oil Machinery Maintenance Online. July 16, 2001. *Air Compressors* [Online]. Available URL: <http://www.oilmachineryforum.com/air.htm>.

University of Florida Environmental Health and Safety (UFEHS). July 26, 2001. *Compressed Air Safety: General safety requirements for compressed air* [Online]. Available URL: http://www.ehs.ufl.edu/General/Shop/comp_air.htm.

7.11 Lighting

7.11.1 Introduction

Recent studies reveal that over 20% of the nation's electricity consumption is absorbed into various types of lighting products and systems. Currently, a majority of America's electric lighting depends on either incandescent bulbs or fluorescent electric lamps for illumination. Within the residential, commercial, and industrial sectors, the potential impact of advanced lighting technologies upon energy conservation is great (Leung 2001d).

7.11.2 Types of Lamps

7.11.2.1 Incandescent Lamps

An incandescent lamp harnesses light from a heated material. Electric current flows through a thin tungsten wire (filament) and heats the filament to about 3000°C, which causes heat and light to emit. The bulky globe or shell is under a vacuum, forming a heat insulator to keep the bulb and socket from getting too hot. The filament also produces infrared (heat) radiation, some of which is absorbed by the glass bulb wall as it passes, contributing more heat to the bulb. In addition, an inert gas is inside the bulb to prevent the filament from burning out (Leung 2001c).

Incandescent bulbs are now considered the least energy-efficient light source and are considered the traditional format of electric lighting. Incandescent bulbs dissipate a lot of the electricity they use as heat to accompany the light emitted from its glowing filament.

- Facts about incandescent lamps (Leung 2001a):
 - The rare gas krypton is mixed with the nitrogen and argon inside the glass bulb to allow the filament to operate at a higher temperature (brighter light).
 - Potential life maximized to 1,000 hours of operation and 22 lumens of light output per watt.
 - Available in compact fused-quartz glass tubes.
 - Relatively inexpensive (\$.60 to \$1), convenient installation, and availability.
 - 10% of energy emitted is in the form of light.
 - Has highest color rendition index (i.e., how accurately a light source represents an object's color compared to an ideal source like the sun) with a CRI of around 95.

7.11.2.2 Fluorescent Lamps (Leung 2001c)

A fluorescent lamp is a low-pressure mercury vapor lamp confined in a glass tube, which is coated on the inside with a fluorescent material known as phosphor. The energized filament delivers electrons to the ionized inert gas within (usually argon), forming a plasma that conducts electricity. The ballast limits the flow of the current through the tube. Consequently, the plasma excites the mercury vapor atoms, which then emits a spectra of red, green, blue, and ultraviolet lights. The internal phosphor coating then converts the ultraviolet light into other colors.

- Facts about fluorescent lamps
 - The efficacy of the ultraviolet light transmission is dependent on the type of phosphor used.
 - On average, 40 watts of energy in a fluorescent tube produces as much as a 150-watt incandescent bulb.
 - Compared to traditional incandescent bulbs, less heat is generated from the filament at similar lighting output.

7.11.2.3 Compact Fluorescent Lights

The classic applications for compact fluorescents are outdoors lighting and security lighting where they run steadily for extended periods.

- Facts about compact fluorescent lights
 - Frequent on/off switching affects its claimed life noticeably.
 - Specialized designs and smaller size.
 - Compatible with existing screw sockets; hence, relamping expenses are not an issue.
 - Average life of a compact fluorescent light is roughly 10,000 hours.
 - A 13-watt compact fluorescent lamp replaces a 60-watt incandescent (ballast loss amounts to about 2 watts).

7.11.2.4 Halogen Lamps (Leung 2001a)

A halogen lamp is an incandescent bulb with a halogen gas added to reduce evaporation. Halogen lamps run at a higher temperature providing a whiter light and greater efficiency. Widely used for display, accent lighting, halls, and lobbies, halogen lamps are used in many of the more modern lighting fixtures. Other types of popular halogen lamps are described next.

- **Low-pressure sodium** – This light source converts nearly 35% of its energy consumed into light. Low-pressure sodium bulbs should last at least 10,000 hours and deliver as much light at the end of their life as in the beginning. However, they are the most expensive lighting source. They are also the largest, and hence, most difficult to control in terms of light distribution. In addition, because of their singular yellow color, they have very low CRI. Objects under low-pressure sodium illumination appear yellow, gray, or black.
- **High-intensity discharge lighting** – These light sources are the elite, energy-efficient lighting devices on the market today for outdoor illumination. Each of these lamps requires a specially designed ballast and has a high initial cost. However, their lower operating cost rapidly returns the initial investment. High-intensity discharge lamps have one potential drawback that may limit their use—a start-up delay from 1 to 7 minutes from the time they are switched on until they fully illuminate. There are two particular types:
 - **Metal halide lamps** – Metal halide lamps have the best CRI of the high-intensity discharge lamps. They are sometimes used for commercial interior lighting because of their excellent color and are the preferred light source for stadiums where there are television broadcasts. They are more efficient than mercury vapor lamps while having the same light output.

- **High-pressure sodium lamps** – High-pressure sodium lamps produce a golden white color that tends to blacken red and blue objects. Because their CRI is about 25, these lamps are rarely used for interior commercial lighting. They are used more frequently for interior industrial applications, such as in warehouses and manufacturing. Their small size and excellent efficiency make them the most popular choice for street and area lighting.

7.11.3 Key Components

7.11.3.1 Ballast (Hetherington Industries Incorporated 2001a)

The ballast regulates the current drawn by the lamp, and is the heart of any fluorescent fixture. There are several types and grades of ballasts to accomplish this end.

- **Preheat ballasts** – Preheat type ballasts require a starter. The preheat ballast typically wastes only about 2 watts or less energy to heat, and it can be used to start fluorescent lamps down to 0 degrees.
- **Outdoor ballasts** – Underwriters Laboratory (UL) Type 1 preheat ballasts contain no materials which might absorb moisture, and are required in damp location fixtures. Outdoor preheat ballasts are sometimes mistakenly called cold weather preheat ballasts. Outdoor ballasts are potted in tar, and are suitable for wet location fixtures exposed to direct water spray. The actual ballast is the same; the packaging is different.
- **Rapid start ballasts** – There are standard rapid start ballasts, low heat ballasts, very low heat ballasts, and super low heat ballasts. A rapid start ballast operates at about 180 degrees. Every 10 degrees rise above 180 degrees will half the average life of a ballast. If a fixture is cycling on and off during operation, it is because the ballast is exceeding the 205 degrees set by the thermal cut out device in the ballast. The ballast is running too hot, and obviously will fail much sooner than necessary. Upgrading to a low heat, very low heat, or super low heat ballast is recommended. The ballast grade required depends upon the heat dissipating ability of the fixture, the heat conductivity of the mounting surface of the fixture, and prevailing line voltage.

There are cold weather, rapid start ballasts capable of starting a fluorescent lamp below 50 degrees; however, you must specify this requirement to the manufacturer. The quality of a magnetic ballast or its ability to control lamp current to a predefined value over a wide range of line voltage, and its operating temperature are a function of the quality of the magnetic material in the ballast core, the cross section of the core, and the gauge of the copper wire used.

- **Electronic ballasts** – Electronic ballasts are available for several lamps; however, most electronic ballasts available today are for the 4- and 8-foot fluorescent lamp. These ballasts drive the lamp at high frequency, provide improved lumen output, and exhibit very low energy loss in the ballast. Some manufacturers claim double the life expectancy of a magnetic ballast.

7.11.3.2 Diffusers (Hetherington Industries Incorporated 2001b)

Diffusers are made of non-yellowing acrylic, never styrene, and are either injection molded, vacuum formed, or extruded. Polycarbonate diffusers are used on vandal resistant fixtures and appear as options on certain other fixtures providing an optional vandal resistant design.

7.11.3.3 Shielding (Hetherington Industries Incorporated 2001b)

Shielding is provided as non-yellowing, clear prismatic acrylic. Either silver or gold parabolic louvers can be specified as options in either 1/2- or 1 1/2-inch cells. Polarizing shielding should be considered for computer facilities where reducing the veiling reflections in a monitor is of paramount importance.

7.11.3.4 Reflectors (Hetherington Industries Incorporated 2001b)

Silver film over aluminum reflectors is provided where specified. The reflectors either snap into tabs provided in the back of the fixture, or are held using studs in the fixture body.

7.11.4 Safety Issues

At one time, good lighting simply meant enough lighting. However, ergonomic studies in business offices attest to the importance of lighting. Improper lighting can cause rapid fatigue, headaches, eyestrain, blurred vision, dry and irritated eyes, slowed refocusing, neck ache, backache, sensitivity to light, double vision, and more.

Aside from the health issues, workers are also less productive. Computer monitors complicate matters. With an increased number of people using home offices with computers, we need to apply what we have learned in commercial lighting and adapt it to suit home office needs and décor.

In general, the light should be brightest on your immediate work area, but do not over-illuminate or you will create too much contrast. Lighting levels should decrease as you move into the general environment of the room. Aim for a 5:3:1 ratio for work, peripheral work area, and immediate surroundings, respectively. The best way to achieve a proper balance is with a combination of general lighting (including controlled daylighting) and task lighting (DoItYourself.com 2001c).

Safety is of utmost importance when working with electricity. Develop safe work habits and stick to them. Be very careful with electricity. It may be invisible, but it can be dangerous if not understood and respected.

7.11.5 Cost and Energy Efficiency (DoItYourself.com 2001a)

7.11.5.1 What is the Most Efficient Lighting System?

The most efficient lighting system depends partly on the specific application, but certain equipment is commonly found in effective lighting systems.

Energy-efficient fluorescent lamps, for example, save 15% to 20% of the wattage used by standard fluorescents (T12-type) and last just as long. Although the efficient lamps (T8-type) are more expensive than the T12 lamps, the energy savings more than compensate for the extra cost. T8 lamps are a popular choice to replace conventional T12 lamps, because they provide 98% as much light as do standard lamps and use about 40% less energy when installed with an electronic ballast.

When replacing standard fluorescents with efficient T8 lamps, it is necessary to replace the existing ballasts with electronics ballasts. Electronic ballasts operate at higher frequencies than do conventional electromagnetic ballasts, so these lighting systems convert power to light more efficiently. They also operate 75% more quietly than do conventional electromagnetic ballasts, eliminating the familiar flicker and hum of older fluorescent lights.

Electronic ballasts weigh up to 50% less than do electromagnetic ballasts, resulting in lower shipping costs, easier handling in lower shipping costs, easier handling and installation, and less stress on ceiling supports. Electronic ballasts feature cooler operation than do conventional ballasts—electronic ballasts are 54°F (30°C) cooler than standard ballasts and 22°F (12°C) cooler than energy-saving electromagnetic ballasts. Cooler operation extends the lives of electronic ballasts and reduces the waste heat from the lights, which contributes to cooling costs.

In some situations, specular reflectors can increase the efficiency of a typical lighting unit by about 10 percentage points by reflecting additional light into the work space. Using specular reflectors makes it possible to remove half the existing fluorescent tubes with a minimal reduction in light levels. Retrofitting specular reflectors and reducing the number of lamps can decrease lighting costs by 50%. Specular reflectors installed with energy-efficient fluorescent lamps and electronic ballasts can reduce lighting energy costs by as much as 70%.

Although most lights in commercial buildings are fluorescent, incandescent light bulbs serve about 20% of commercial lighted floor space and account for nearly 40% of commercial lighting energy use. Commercial fluorescents between 7 and 18 watts can be used to convert incandescents with 20 to 150 watts per fixture. Compact fluorescents last about 10 times longer than do incandescent bulbs. Lights that operate much of the time, such as hallway or stairwell lamps, are popular applications for these lamps.

Lighting controls can also play a role in saving energy. Manual controls should be used in spaces that accommodate different tasks or that have access to daylight, and occupants should be encouraged to shut lights off when they are not needed. Automatic controls such as occupancy sensors are convenient for turning lights off when areas are unoccupied. Auto-dimming controls are coming on the market that automatically adjust light levels to existing daylight.

7.11.6 Maintenance Requirements (Rea 2000)

To assure lighting quality, whether for task performance, safety, or aesthetic reasons, proper maintenance is required. Lack of maintenance can have a negative effect on human performance, perception of an area, safety, and security. It can also waste energy. The combined effect of equipment age and dirt depreciation can reduce illuminance by 25% to 50% or more, depending on the application and equipment used.

- Maintenance programs
 - Group relamping – Group relamping entails replacing all of the lamps in a system together after a fixed interval, called the economic group relamping interval. Group relamping can reduce the cost of operating a lighting system while keeping illuminance levels close to the design value.
 - Periodic planned cleaning – Cleaning the lighting system usually entails washing or otherwise removing dirt from the luminaries, occasionally cleaning and repainting room surfaces, and occasionally cleaning air supply vents to prevent unnecessary dirt distribution.

7.11.7 Diagnostic Tools

- **Thermography** – An infrared thermometer or camera allows for an accurate, non-contact assessment of temperature. Applications for lighting include ballast and breaker contact temperatures.

Recorded values should be compared with trended values for condition assessment. More information on thermography can be found in Chapter 6.

7.11.8 Lighting Checklist

Description	Comments	Maintenance Frequency			
		Daily	Weekly	Semi-Annually	Annually
Lighting system use/sequencing	Turn off/sequence unnecessary lighting systems	X			
Overall visual inspection	Complete overall visual inspection to be sure all equipment is operating and safety systems are in place	X			
Lighting use/sequencing	Turn off unnecessary lights	X			
On time	Assess and reduce where possible lighting on time	X			
Task lighting	Highlight the importance and efficiency of task lighting	X			
Use daylighting	Make use of daylighting where possible	X			
Replace burned out lamps	Replace flickering and burned out lamps. Burned out lamps can cause ballast damage.		X		
Perform survey of lighting use	Perform survey of actual lighting use to determine lighting need			X	
Illumination levels	Measure footcandle levels. Where possible, reduce illumination levels to industry standards.			X	
Clean lamps/fixtures	Lamps and fixtures should be wiped clean to assure maximum efficiency			X	
Clean walls, ceilings, floors	Clean surfaces reflect more light			X	
Repaint with light colors	When repainting, use light colors to reflect more light			X	
Replacement lenses	Replace lens shielding that has become yellow or hazy			X	

7.11.9 References

DoItYourself.com. August 12, 2001a. *Buildings that Save Money with Efficient Lighting* [Online]. Available URL: <http://doityourself.com/electric/buildingssavemoneywithefficientlight.htm>. Reprinted with permission of DoItYourself.com.

DoItYourself.com. August 12, 2001b. *Electricity-Introduction* [Online]. Available URL: <http://search.excite.com/t/sr=webresult|ss=%22lighting%22%2B%22safety+tips%22|id=12521472;pos=6;http://www.doityourself.com/electric/electintro.htm>. Reprinted with permission of DoItYourself.com.

DoItYourself.com. August 12, 2001c. *Home Lighting Office* [Online]. Available URL: <http://doityourself.com/electric/lighthomeoffice.htm>. Reprinted with permission of DoItYourself.com.

Hetherington Industries Incorporated. August 10, 2001a. *Ballasts* [Online]. Available URL: <http://www.hetherington.com/ballasts.html>. Reprinted with permission of Hetherington Industries Incorporated.

Hetherington Industries Incorporated. August 10, 2001b. *Diffusers, Shielding, and Reflectors* [Online]. Available URL: <http://www.hetherington.com/dif.html>. Reprinted with permission of Hetherington Industries Incorporated.

Lawrence Livermore National Laboratory. August 3, 2001a. *Exterior Security Light Causes Structural Fire*, August 5, 1999, Environmental, Safety & Health [Online report]. Available URL: http://www.llnl.gov/es_and_h/lessons/ExterSecurityLightFire.html.

Lawrence Livermore National Laboratory. August 3, 2001b. *Use Halo Lights Correctly*, April 23, 1998, Environmental, Safety & Health [Online report]. Available URL: http://www.llnl.gov/es_and_h/lessons/sa_use_halo_e.html.

Leung S. August 29, 2001a. *Current Technology in Lighting*. Class Project for NucE 201, Energy Systems, Prof. D. Ruzic, Fall 1996, Plasma Material Interaction Group, University of Illinois at Urbana-Champaign [Online]. Available URL: <http://starfire.ne.uiuc.edu/~ne201/1996/leung/current.html>. Reprinted with permission of D.N. Ruzik, Plasma Material Interaction Group, University of Illinois at Urbana-Champaign.

Leung S. August 29, 2001b. *History and Background of Electric Lighting*. Class Project for NucE 201, Energy Systems, Prof. D. Ruzic, Fall 1996, Plasma Material Interaction Group, University of Illinois at Urbana-Champaign [Online]. Available URL: <http://starfire.ne.uiuc.edu/~ne201/1996/leung/history.html#Incandescent>. Reprinted with permission of D.N. Ruzik, Plasma Material Interaction Group, University of Illinois at Urbana-Champaign.

Leung S. August 29, 2001c. *History and Background of Fluorescent Lighting*. Class Project for NucE 201, Energy Systems, Prof. D. Ruzic, Fall 1996, Plasma Material Interaction Group, University of Illinois at Urbana-Champaign [Online]. Available URL: <http://starfire.ne.uiuc.edu/~ne201/1996/leung/history.html#Flourescent/>. Reprinted with permission of D.N. Ruzik, Plasma Material Interaction Group, University of Illinois at Urbana-Champaign.

Leung S. August 29, 2001d. *Role of Lighting Technologies in Energy Conservation*. Class Project for NucE 201, Energy Systems, Prof. D. Ruzic, Fall 1996, Plasma Material Interaction Group, University of Illinois at Urbana-Champaign [Online]. Available URL: <http://starfire.ne.uiuc.edu/~ne201/1996/leung/home.html>. Reprinted with permission of D.N. Ruzik, Plasma Material Interaction Group, University of Illinois at Urbana-Champaign.

Rea M.S. (Editor-in-Chief). 2000. *Lighting Handbook: Reference & Application*, 8th ed, Illuminating Engineering Society of North America, New York.

Rocky Mountain Institute. August 13, 2001. *Efficient Commercial/Industrial Lighting, Energy* [Online]. Available URL: <http://www.rmi.org/sitepages/pid297.php>. Reprinted with permission of the Rocky Mountain Institute.

U.S. Department of Energy (DOE). August 16, 2001. *Mercury Exposure from Metal Halide Lights*. 1999-RL-HNF-0053, December 13, 1999, Lessons Learned Database, Lessons Learned Information Services [Online report]. Available URL: http://tis.eh.doe.gov/ll/ldb/detail.CFM?Lessons__IdentifierIntern=1999%2DRL%2DHNF%2D0053.

Chapter 8 O&M Frontiers

As old a topic as O&M is, there are a number of new technologies and tools targeting the increased efficiency of O&M. As with most new technology introduction, these tools are in various stages of commercialization; for up-to-date information on each tool, contact information is provided in this chapter.

As previously mentioned, we are not able to provide a detailed description of all tools and technologies available. What we do provide are some of the more common tools that are currently, or nearly, commercially available. To locate additional resources, the authors of this guide recommend contacting relevant trade groups, databases, and the world-wide web.

8.1 ACRx Handtool/Honeywell HVAC Service Assistant

Developed by Field Services, Inc., and now marketed by Honeywell as the “HVAC Service Assistant,” this tool was designed to provide diagnostics for rooftop HVAC equipment. The tool combines a handheld PDA, multiple pressure/ temperature gauges into a single tool that provides expert diagnostic analysis of HVAC equipment to the service technician. This unit automates the detection and diagnosis of problems difficult to identify in compressors, heat exchangers, and expansion valves.

More information about the HVAC Service Assistant

Contact Honeywell at: (800) 345-6770, ext. 7247
www.customer.honeywell.com or www.honeywell.com/building/components.

8.2 Decision Support for O&M (DSOM®)

The DSOM® tool is a condition-based O&M hardware and software program designed to provide facility staff with intuitive actions to implement efficient, life-cycle asset management. DSOM was developed by researchers at the U.S. Department of Energy’s Pacific Northwest National Laboratory (PNNL).

Based on the concept of condition-based management, DSOM focuses on finding the balance between high-production rates, machine stress, and failure. DSOM allows online condition monitoring of equipment and provides early warning signs of degraded performance. DSOM’s diagnostic capabilities empower the operations staff to become the first line of maintenance. Moreover, a customized, integrated database, and intuitive access system provide the information all staff need to make informed decisions about how to operate their plant more effectively. Dramatic savings are achievable because DSOM 1) improves process efficiency, 2) cuts maintenance costs, 3) extends equipment life, and 4) reduces energy consumption and associated harmful emissions.

The DSOM technology was developed under government research funding from the U.S. Department of Energy. In 1994, it was installed at the central heating plant of the Marine Corps’ Air Ground Combat Center in Twentynine Palms, Calif. Implementation at Twentynine Palms established proof of principle and verification of value. Recent installations have been completed at Marine Corp Recruiting District Parris Island and a large metropolitan housing project.

More information about DSOM

Contact Dick Meador (509) 372-4098
www.pnl.gov/dsom/.

8.3 Performance and Continuous Commissioning Analysis Tool (PACRAT)

PACRAT is a versatile diagnostic tool developed by Facility Dynamics Engineering to detect problems with HVAC equipment. This tool is designed to provide automated diagnostic capabilities for air handlers, zone distribution systems, chillers, hydronic systems, and whole-building energy use. PACRAT makes use of time-series data collected by existing energy management and control systems (EMCS) or other data logging equipment. Once collected, the data are processed making use of an extensive automation of expert rules to assess HVAC system performance (Friedman and Piette 2001). PACRAT is designed to calculate and report deviations from baseline operation and estimate the resulting cost of wasted energy.

More information about PACRAT

Contact E. Lon Brightbill (410) 290-0900
www.facilitydynamics.com/.

8.4 The Whole-Building Diagnostician (WBD)

The Whole-Building Diagnostician (WBD) is a modular diagnostic software system that provides detection and diagnosis of common problems associated with the operation of HVAC systems and equipment in buildings. The WBD tracks overall building energy use, monitors the performance of air-handling units, and detects problems with outside-air control. This tool uses time-series data as collected by an EMCS or other data logging equipment. Its development is part of the commercial buildings research program of the U.S. Department of Energy's Office of Building Technology, State and Community Programs.

More information about WBD

Contact Michael Brambley (509) 375-6875
www.buildings.pnl.gov:2080/wbd/.

8.5 Reference

Friedman, H., and M.A. Piette. 2001. *Comparative Guide to Emerging Diagnostic Tools for Large Commercial HVAC Systems*. LBNL No. 48629, Lawrence Berkeley National Laboratory, Berkeley, California.

Chapter 9 Ten Steps to *Operational Efficiency*

Step 1: Strive to ***increase management awareness*** and appreciation of the operations and maintenance program/department.

- - Consider developing a maintenance mission statement and requesting/requiring management sign-off.
- Consider developing a maintenance plan and requesting/requiring management sign-off.
- Begin the development of the OMETA linkages.
 - Develop key points of contact within other departments that can participate in the O&M mission.

Step 2: Commit to begin ***tracking Operations and Maintenance activities***.

- Need to understand where O&M time is spent.
- Need to understand where O&M dollars are spent.
- - Consider (strongly) purchasing or enhancing a Computerized Maintenance Management System and commit to its implementation and use.

Step 3: Through tracking begin to ***identify your troubled equipment and systems***.

- Make a list of these systems and prioritize them.

Step 4: Commit to ***addressing at least one of these troubled systems***.

- - Begin base-lining/tracking this system.
 - System operations and history.
 - System maintenance and history.
 - System costs, time to service, downtime, resulting overtime, etc.

Step 5: Commit to ***striving for Operational Efficiency of this system***.

- - Strive to understand how to properly operate this system.
 - Define and complete operator training needs.
- Strive to understand how to properly maintain this system.
 - Define and complete maintenance training needs.

Step 6: Commit to ***purchasing or contracting for some form(s) of diagnostic, metering, or monitoring equipment***.

Step 7: Commit to ***trending the collected tracking and diagnostic data.***

- Take to time to understand the data.
- - Look for and develop “project opportunities.”
 - Develop appropriate cost justification metrics.

Step 8: Select, request funding for, and ***complete first “Operational Efficiency” project.***

- Start small, pick a project that will be a winner.
- Carefully document all findings.
- Present success in terms management will understand.

Step 9: Strive to ***highlight this success – capitalize on visibility opportunities.***

- Consider writing an internal success story/case study.
- Submit finding to trade publication or industry conference.

Step 10: Commit to ***choosing the next piece of equipment...go to Step 3.***

- Steps 1 and 2 are ONGOING ACTIVITIES!

Appendix A

Glossary of Common Terms

Appendix A

Glossary of Common Terms

Absorption chiller – A refrigeration machine using heat as the power input to generate chilled water.

Adjustable speed drive – A means of changing the speed of a motor in a step-less manner. In the case of an AC motor, this is accomplished by varying the frequency.

Aerator – A device installed in a faucet or showerhead that adds air to the water flow, thereby maintaining an effective water spray while reducing overall water consumption.

Air changes – Replacement of the total volume of air in a room over a period of time (e.g., 6 air changes per hour).

Ambient temperature – The temperature of the air surrounding an object.

Ballast – A device used to supply the proper voltage and limit the current to operate one or more fluorescent or high-intensity discharge lamps.

Base – A selected period of time with consumption levels or dollar amounts, to which all future usage or costs are compared.

Blackwater – Water discharged from toilets, urinals, and kitchen sinks.

BLCC – Building Life Cycle Costing.

Blowdown – The discharge of water from a boiler or a cooling tower sump that contains a high proportion of total dissolved solids.

British thermal unit (Btu) – The amount of heat required to raise the temperature of one pound of water 1 degree Fahrenheit at or near 39.2 degrees Fahrenheit.

Building commissioning – A systematic process of assuring that a building facility performs in accordance with design intent and the owner's operational needs. Verification and documentation that all building facility systems perform interactively in an efficient manner and that operations and maintenance personnel are well trained.

Building envelope – The exterior surfaces of a building that are exposed to the weather, i.e., walls, roof, windows, doors, etc.

Celsius (Centigrade) – The temperature at which the freezing point of water is 0 degrees and the boiling point is 100 degrees at sea level.

Centrifugal fan – A device for propelling air by centrifugal action.

cfm – Cubic feet per minute usually refers to the volume of air being moved through an air duct.

Chiller – A refrigeration machine using mechanical energy input to drive a centrifugal compressor to generate chilled water.

Coefficient of performance – Ratio of tons of refrigeration produced to energy required to operate equipment.

Coefficient of utilization – Ratio of lumens on the work surface to total lumens emitted by the lamps.

Cold deck – A cold air chamber forming a part of an air conditioning system.

Combined wastewater – A facility's total wastewater, both graywater and blackwater.

Color rendering index (CRI) – The color appearance of an object under a light source as compared to a reference source.

Condensate – Water obtained by changing the state of water vapor (i.e., steam or moisture in air) from a gas to a liquid usually by cooling.

Condenser – A heat exchanger which removes heat from vapor, changing it to its liquid state. In refrigeration systems, this is the component which rejects heat.

Conduction – Method of heat transfer in which heat moves through a solid.

Convection – Method of heat transfer in which heat moves by motion of a fluid or gas, usually air.

Cooling tower – A device that cools water directly by evaporation.

Damper – A device used to limit the volume of air passing through an air outlet, inlet, or duct.

Degree days – The degree day for any given day is the difference between 65 degrees and the average daily temperature. For example, if the average temperature is 50 degrees, the degree days is $65 - 50 = 15$ degree days. When accumulated for a season, degree days measure the severity of the entire season.

Demand load – The maximum continuous requirement for electricity measured during a specified amount of time, usually 15 minutes.

Demand factor – The ratio of the maximum demand of a system to the total connected load on the system.

Double bundle chiller – A condenser usually in a refrigeration machine that contains two separate tube bundles allowing the option of rejecting heat to the cooling tower or to another building system requiring heat input.

Dry bulb temperature – The measure of the sensible temperature of air.

Economizer cycle – A method of operating a ventilation system to reduce refrigeration load. Whenever the outside air conditions are more favorable (lower heat content) than return air conditions, outdoor air quantity is increased.

Efficacy – Ratio of usable light to energy input for a lighting fixture or system (lumens per watt)

Energy management system – A microprocessor-based system for controlling equipment and monitoring energy and other operating parameters in a building.

Energy requirement – The total yearly energy used by a building to maintain the selected inside design conditions under the dynamic impact of a typical year's climate. It includes raw fossil fuel consumed in the building and all electricity used for lighting and power. Efficiencies of utilization are applied and all energy is expressed in the common unit of Btu.

Energy utilization index – A reference which expresses the total energy (fossil fuel and electricity) used by a building in a given period (month, year) in terms of Btu's/gross conditioned square feet.

Enthalpy – The total heat content of air expressed in units of Btu/pound. It is the sum of the sensible and latent heat.

Evaporator – A heat exchanger in which a liquid evaporates while absorbing heat.

Evaporation – The act of water or other liquids dissipating or becoming vapor or steam.

Faucet aerator – Either a device inserted into a faucet head or a type of faucet head that reduces water flow by adding air to the water stream through a series of screens and/or small holes through a disk. An aerator produces a low-flow non-splashing stream of water.

Flow restrictors – Washer-like disks that fit inside faucet or shower heads to restrict water flow.

Flushometer valve toilet – Also known as a pressure assisted or pressurized tank toilet, a toilet with the flush valve attached to a pressurized water supply tank. When activated, the flush valve supplies the water to the toilet at the higher flow rate necessary to flush all of the waste through the toilet trap and into the sewer.

Foot candle – Illumination at a distance of one foot from a standard candle.

Gravity flush toilet – A toilet designed with a rubber stopper that releases stored water from the toilet's tank. Gravity flow water then fills the bowl and carries the waste out of the bowl, through the trap and into the sewer.

Graywater – Used water discharged by sinks, showers, bathtubs, clothes washing machines, and the like.

Gross square feet – The total number of square feet contained in a building envelope using the floors as area to be measured.

Heat gain – As applied to HVAC calculations, it is that amount of heat gained by space from all sources including people, lights, machines, sunshine, etc. The total heat gain represents the amount of heat that must be removed from a space to maintain indoor comfort conditions. This is usually expressed in Btu's per hour.

Heat loss – The heat loss from a building when the outdoor temperature is lower than the desired indoor temperature it represents the amount of heat that must be provided to a space to maintain indoor comfort conditions. This is usually expressed in Btu/hour.

Heat pump – A refrigeration machine possessing the capability of reversing the flow so that its output can be either heating or cooling. When used for heating, it extracts heat from a low temperature source.

Heat transmission coefficient – Any one of a number of coefficients used in the calculation of heat transmission by conduction, convection, and radiation through various materials and structures.

Horsepower (hp) – British unit of power, 1 Hp = 746 watts or 42,408 Btu's per minute.

Hot deck – A hot air chamber forming part of a multi-zone or dual duct air handling unit.

Humidity, relative – A measurement indicating the moisture content of the air.

IAQ – Indoor Air Quality.

IEQ – Indoor Environmental Quality.

Infiltration – The process by which outdoor air leaks into a building by natural forces through cracks around doors and windows.

Latent heat – The quantity of heat required to effect a change in state of a substance.

Life cycle cost – The cost of the equipment over its entire life including operating costs, maintenance costs, and initial cost.

Low flow toilet – A toilet that uses 3.5 gallons of water per flush.

Load profile – Time distribution of building heating, cooling, and electrical load.

Lumen – Unit of measurement of rate of light flow.

Luminaire – Light fixture designed to produce a specific effect.

Makeup – Water supplied to a system to replace that lost by blowdown, leakage, evaporation, etc. Air supplied to a system to provide for combustion and/or ventilation.

Modular – System arrangement whereby the demand for energy (heating, cooling) is met by a series of units sized to meet a portion of the load.

Orifice plate – Device inserted in a pipe or duct which causes a pressure drop across it. Depending on orifice size, it can be used to restrict flow or form part of a measuring device.

ORSAT apparatus – A device for measuring the combustion components of boiler or furnace flue gasses.

Piggyback operation – Arrangement of chilled water generation equipment whereby exhaust steam from a steam turbine driven centrifugal chiller is used as the heat source of an absorption chiller.

Plenum – A large duct used as a distributor of air from a furnace.

Potable water – Clean, drinkable water; also known as “white” water.

Power factor – Relationship between KVA and KW. The power factor is one when the KVA equals the KW.

Pressurized tank toilet – A toilet that uses a facility’s waterline pressure by pressurizing water held in a vessel within the tank; compressing a pocket of trapped air. The water releases at a force 500 times greater than a conventional gravity toilet.

Pressure reducing valve – A valve designed to reduce a facility’s water consumption by lowering supply-line pressure.

Radiation – The transfer of heat from one body to another by heat waves without heating the air between them.

R Value – The resistance to heat flow of insulation.

Seasonal efficiency – Ratio of useful output to energy input for a piece of equipment over an entire heating or cooling season. It can be derived by integrating part load efficiencies against time.

Sensible heat – Heat that results in a temperature change, but no change in state.

Siphonic jet urinal – A urinal that automatically flushes when water, which flows continuously to its tank, reaches a specified preset level.

Source meter – A water meter that records the total waterflow into a facility.

Sub meter – A meter that record energy or water usage by a specific process, a specific part of a building, or a building within a larger facility.

Therm – A unit of gas fuel containing 100,000 Btu’s.

Ton (of refrigeration) – A means of expressing cooling capacity: 1 ton = 12,000 Btu/hour cooling (removal of heat).

U Value – A coefficient expressing the thermal conductance of a composite structure in Btu’s per (square foot) (hour) (degree Fahrenheit difference).

Ultra low flow toilet – A toilet that uses 1.6 gallons or less of water per flush.

Variable speed drive – See “Adjustable speed drive.”

Variable frequency drive – See “Adjustable speed drive.”

Veiling reflection – Reflection of light from a task or work surface into the viewer’s eyes.

Vapor barrier – A moisture impervious layer designed to prevent moisture migration.

Wet bulb temperature – The lowest temperature attainable by evaporating water in the air without the addition or subtraction of energy.

Xeriscaping – The selection, placement, and care of water-conserving and low-water-demand ground covers, plants, shrubs, and trees in landscaping.

Appendix B

FEMP Staff Contact List

Appendix B

FEMP Staff Contact List

General Information

FEMP Help Desk: 1-800-363-3732 (DOE-EREC)

FEMP Main Office: (202) 586-5772

FEMP Fax: (202) 586-3000

Mailing Address:

EE-90

1000 Independence Ave., SW

Washington, D.C. 20585-0121

Elizabeth Shearer, Director

(202) 586-5772

Schuyler Schell

Office Director - Technical Assistance, Financing,
and Departmental Utility and Energy Team

(202) 586-9015

schuyler.schell@ee.doe.gov

Brian Connor

Office Director - Planning, Budget, and Outreach

(202) 586-3756

FEMP Administration

Helen Krupovich

Weekly Reporting

(202) 586-9330

helen.krupovich@ee.doe.gov

Ladeane Moreland

Administrative Assistant

(202) 586-9846

ladeane.moreland@ee.doe.gov

Customer Service, Planning, and Outreach

Nellie Tibbs-Greer

Awards Program/Technical Assistance Communications

(202) 586-7875

nellie.tibbs@ee.doe.gov

Annie Haskins
Outreach/FEMP Focus
(202) 586-4536
annie.haskins@ee.doe.gov

Rick Klimkos
Annual Report/Interagency Coordination
(202) 586-8287
rick.klimkos@ee.doe.gov

Michael Mills
Program Evaluation
(202) 586-6653
michael.mills@ee.doe.gov

External Service Delivery

Ted Collins
Training Programs/New Technology Demonstration Program
(202) 586-8017
theodore.collins@ee.doe.gov

Anne Sprunt Crawley
Renewable Energy, Greening, and Software
(202) 586-1505
anne.crawley@ee.doe.gov

Danette Delmastro
Super ESPC Program
(202) 586-7632
danette.delmastro@ee.doe.gov

Beverly Dyer
Sustainability Program Manager
(202) 586-7241
beverly.dyer@ee.doe.gov

Brad Gustafson
Utility Program
(202) 586-5865
brad.gustafson@ee.doe.gov

Shawn Herrera
Design Assistance
(202) 586-1511
shawn.herrera@ee.doe.gov

Ab Ream
O&M Program Manager
(202) 586-7230
ab.ream@ee.doe.gov

Tatiana Strajnic
Super ESPC Program
(202) 586-9230
tatiana.strajnic@ee.doe.gov

Alison Thomas
Procurement
(202) 586-2099
alison.thomas@ee.doe.gov

Principal DOE National Laboratory Liaisons

Bill Carroll
Lawrence Berkeley National Laboratory
(510) 486-4890
wlcarroll@lbl.gov

Mary Colvin
National Renewable Energy Laboratory
(303) 386-7511
mary_colvin@nrel.gov

Patrick Hughes
Oak Ridge National Laboratory
(865) 574-9337
pj1@ornl.gov

Paul Klimas
Sandia National Laboratory
(505) 844-8159
pcklima@sandia.gov

Bill Sandusky
Pacific Northwest National Laboratory
(509) 375-3709
bill.sandusky@pnl.gov

DOE Regional Office FEMP Team

For more information about how FEMP can help your agency save energy, contact a regional office representative in your area.



Central

Denver Regional Office
1617 Cole Boulevard
Golden, Colorado 80401
FAX: (303) 275-4830

Randy Jones, 303-275-4814
randy_jones@nrel.gov

Midwest

Chicago Regional Office
1 South Wacker Drive, Suite 2380
Chicago, Illinois 60606
FAX: (312) 886-8561

Sharon Gill, (312) 886-8573
sharon.gill@ee.doe.gov

Michael Bednarz, (312) 886-8585
michael.bednarz@ee.doe.gov

Southeast

Atlanta Regional Office
75 Spring Street, SW, Suite 200A
Atlanta, Georgia 30303A
FAX: (404) 562-0538A

Doug Culbreth, (919) 782-5238
carson.culbreth@hq.doe.gov

Lisa Hollingsworth (Atlanta RO)
(404) 562-0569
lisa.hollingsworth@ee.doe.gov

Mid-Atlantic

Philadelphia Regional Office
1880 JFK Boulevard, Suite 501
Philadelphia, Pennsylvania 19102
FAX: (212) 264-2272

Claudia Marchione
(215) 656-6967

Northeast

Boston Regional Office
JFK Federal Building, Room 675
Boston, Massachusetts 02203
FAX: (617) 565-9723

Paul King, (617) 565-9712
paul.king@hq.doe.gov

Western

Seattle Regional Office
800 Fifth Avenue, Suite 3950
Seattle, Washington 98104
FAX: (206) 553-2200

Cheri Sayer, (206) 553-7838
cheri.sayer@hq.doe.gov

Curtis Framel (Seattle RO)
(206) 553-7841
curtis.framel@hq.doe.gov

Arun Jhaveri (Seattle RO)
(206) 553-2152
arun.jhaveri@hq.doe.gov

Eileen Yoshinaka (Seattle RO in HI)
(808) 541-2564
eileen.yoshinaka@hq.doe.gov

Appendix C

Resources

Appendix C

Resources

The references and resources provided below are by no means all-inclusive. The listed organizations are not endorsed by the authors of this guide and are provided for your information only. To locate additional resources, the authors of this guide recommend contacting relevant trade groups, databases, and the world-wide web.

O&M Professional/Trade Associations

EFCOG

Energy Facility Contractors Group, Maintenance Working Group, Maintenance and Reliability-Center, University of Tennessee, Knoxville-
www.llnl.gov/efcog/EFCOG2/index.html

International Maintenance Institute

P.O. Box 751896
Houston, TX 77275-1896
(815) 481-0869

National Uniform Certification of Building Operators

P.O. Box 2596
Joliet, IL 60434
(815) 726-6144

Society for Maintenance & Reliability Professionals

Operate an emailing/discussion function. Anyone can join by simply sending an email message with the word SUBSCRIBE in the body of the message to: network-request@mailserv.tenagra.com
<http://www.smrp.org/>

Washington Association of Maintenance and Operations Administrators

Educational Facilities Maintenance Professionals in Washington State-
Port Orchard, WA-
(360) 871-3378-

World Federation of Building Service Contractors

10201 Lee Highway, Suite 225
Fairfax, VA 22030
(703) 359-7090

Organizations with Some O&M Interests

Association for Facilities Engineering, AFE

Formerly the American Institute of Plant Engineers. AFE Facilities Engineering Journal <http://www.facilitiesnet.com/NS/NS1afe.html>

Association of Higher Education Facilities Officers

<http://www.appa.org/>

Building Owners and Managers Association

Publish: "How to Design and Manage your Preventive Maintenance Program"

<http://www.boma.org/index2.htm>

Boiler Efficiency Institute

P.O. Box 2255-

Auburn, AL 36831-2255-

(334) 821-3095-

www.boilerinstitute.com-

Facilities Net

For professionals in facility design, construction, and maintenance related to or product of Tradelines who arranges executive level conference on facility programs for corporations and universities.

<http://www.facilitiesnet.com/NS/NS1afe.html>

National Association of Energy Service Companies (NAESCO)

1615 M Street, NW, Suite 800

Washington, D.C. 20036

(202) 822-0955

www.naesco.org

National Association of State Energy Officials (NASEO)

14141 Prince Street, Suite 200

Alexandria, VA 22314

(703) 299-8800

www.naseo.org

National Association of State Procurement Officials (NASPO)

<http://www.naspo.org>

O&M Publications

Building Operating Management

www.facilitiesnet.com/NS

Chilton's Industrial Maintenance and Plant Operation

www.impomag.com

HPAC Engineering

1300 E Ninth Street

Cleveland, OH 44114-1503

(216) 696-7000

www.hpac.com

Industrial Maintenance and Plant Operation

www.impomag.com

Maintenance Solutions

P.O. Box 5268-
Pittsfield, MA 01203-5268-
www.facilitiesnet.com-

Maintenance Technology

(847) 382-8100/Fax: (847) 304-8603
www.mt-online.com

P/PM Technology

SC Publishing-
P.O. Box 2770-
Minden, NV 89423-2770-
(702) 267-3970-

Plant & Facilities Engineering Digest

Adams/Huecore Publishing, Inc.
29100 Aurora Road, Suite 200
Cleveland, OH 44139
(708) 291-5222

Preventative Maintenance Magazine**Reliability Magazine**

www.reliability-magazine.com/

Events Related to O&M

Professional Trade Shows, Inc.

Professional Trade Shows, Inc. produces 30 trade shows and conference events in 25 urban centers throughout the United States. Their primary focus is the plant engineering and maintenance industry, and also produce a select number of material handling and machine tools shows.
<http://www.proshows.com/>

Maintenance Engineering-98

Annual conference sponsored by The Maintenance Engineering Society of Australia Inc. (MESA).-
Contact ME-98-
P.O. Box 5142-
Clayton, Victoria, 3168, Australia-
+61 3 9544 0066, Fax +61 3 9543 5906.-

Association of Energy Engineers

World Energy and Engineering Conference held every November in Atlanta.-
AEE, 700 Indian Trail-
Lilburn, GA 30247-

National Association of State Procurement Officials (NASPO)

Contact: Katie Kroehle (202) 586-4858

National Predictive Maintenance Technology Conference

P/PM Magazine-

Phone: (702) 267-3970; Fax: (702) 367-3941-

Machinery Reliability Conference

Reliability Magazine

www.reliability-magazine.com

Government Organizations

Federal Energy Management Program (FEMP)

U.S. Department of Energy

www.eren.doe.gov/femp

U.S. General Services Administration

www.gsa.gov

Energy Efficiency and Renewable Energy Network (EREN)

www.eren.doe.gov

Appendix D

Suggestions for Additions or Revisions

Appendix D

Suggestions for Additions or Revisions

This guide is a living document, open to periodic updates and improvement. Readers are encouraged to submit suggestions for additions, deletions, corrections, or where to go for other resources.

In addition, we are interested in what has worked at your Federal site. We want to find other case studies and documentation of your successes.

Please send or fax your information to:

Greg Sullivan
Pacific Northwest National Laboratory (PNNL)
P.O. Box 999, MS K6-10
Richland, WA 99352
Fax (509) 372-4370

Additional material to include (please be specific): _____

Additional References/Resources: _____

Case study material (feel free to attach additional sheets): _____
