

# Centrifugal Pumps for Petroleum, Petrochemical, and Natural Gas Industries

API STANDARD 610  
TWELFTH EDITION, JANUARY 2021



## Special Notes

API publications necessarily address problems of a general nature. With respect to particular circumstances, local, state, and federal laws and regulations should be reviewed. The use of API publications is voluntary. In some cases, third parties or authorities having jurisdiction may choose to incorporate API standards by reference and may mandate compliance.

Neither API nor any of API's employees, subcontractors, consultants, committees, or other assignees make any warranty or representation, either express or implied, with respect to the accuracy, completeness, or usefulness of the information contained herein, or assume any liability or responsibility for any use, or the results of such use, of any information or process disclosed in this publication. Neither API nor any of API's employees, subcontractors, consultants, or other assignees represent that use of this publication would not infringe upon privately owned rights.

API publications may be used by anyone desiring to do so. Every effort has been made by the Institute to assure the accuracy and reliability of the data contained in them; however, the Institute makes no representation, warranty, or guarantee in connection with this publication and hereby expressly disclaims any liability or responsibility for loss or damage resulting from its use or for the violation of any authorities having jurisdiction with which this publication may conflict.

API publications are published to facilitate the broad availability of proven, sound engineering and operating practices. These publications are not intended to obviate the need for applying sound engineering judgment regarding when and where these publications should be utilized. The formulation and publication of API publications is not intended in any way to inhibit anyone from using any other practices.

Any manufacturer marking equipment or materials in conformance with the marking requirements of an API standard is solely responsible for complying with all the applicable requirements of that standard. API does not represent, warrant, or guarantee that such products do in fact conform to the applicable API standard.

All rights reserved. No part of this work may be reproduced, translated, stored in a retrieval system, or transmitted by any means, electronic, mechanical, photocopying, recording, or otherwise, without prior written permission from the publisher. Contact the Publisher, API Publishing Services, 200 Massachusetts Avenue NW, Suite 1100, Washington, DC 20001.

*Copyright © 2020 American Petroleum Institute*

## Foreword

Nothing contained in any API publication is to be construed as granting any right, by implication or otherwise, for the manufacture, sale, or use of any method, apparatus, or product covered by letters patent. Neither should anything contained in the publication be construed as insuring anyone against liability for infringement of letters patent.

The verbal forms used to express the provisions in this document are as follows.

**Shall:** As used in a standard, “shall” denotes a minimum requirement in order to conform to the standard.

**Should:** As used in a standard, “should” denotes a recommendation or that which is advised but not required in order to conform to the standard.

**May:** As used in a standard, “may” denotes a course of action permissible within the limits of a standard.

**Can:** As used in a standard, “can” denotes a statement of possibility or capability.

This document was produced under API standardization procedures that ensure appropriate notification and participation in the developmental process and is designated as an API standard. Questions concerning the interpretation of the content of this publication or comments and questions concerning the procedures under which this publication was developed should be directed in writing to the Director of Standards, American Petroleum Institute, 200 Massachusetts Avenue, Suite 1100, Washington, DC 20001. Requests for permission to reproduce or translate all or any part of the material published herein should also be addressed to the director.

Generally, API standards are reviewed and revised, reaffirmed, or withdrawn at least every five years. A one-time extension of up to two years may be added to this review cycle. Status of the publication can be ascertained from the API Standards Department, telephone (202) 682-8000. A catalog of API publications and materials is published annually by API, 200 Massachusetts Avenue, Suite 1100, Washington, DC 20001.

Suggested revisions are invited and should be submitted to the Standards Department, API, 200 Massachusetts Avenue, Suite 1100, Washington, DC 20001, [standards@api.org](mailto:standards@api.org).

# Contents

	Page
<b>1</b>	<b>Scope</b> . . . . . <b>1</b>
<b>2</b>	<b>Normative References</b> . . . . . <b>1</b>
<b>3</b>	<b>Terms, Definitions, Acronyms, and Abbreviations</b> . . . . . <b>4</b>
<b>3.1</b>	<b>Terms and Definitions</b> . . . . . <b>4</b>
<b>3.2</b>	<b>Acronyms and Abbreviations</b> . . . . . <b>11</b>
<b>4</b>	<b>General</b> . . . . . <b>13</b>
<b>4.1</b>	<b>Unit Responsibility</b> . . . . . <b>13</b>
<b>4.2</b>	<b>Classification and Designation</b> . . . . . <b>13</b>
<b>5</b>	<b>Requirements</b> . . . . . <b>22</b>
<b>5.1</b>	<b>Units</b> . . . . . <b>22</b>
<b>5.2</b>	<b>Statutory Requirements</b> . . . . . <b>22</b>
<b>5.3</b>	<b>Hierarchy of Requirements</b> . . . . . <b>22</b>
<b>6</b>	<b>Basic Design</b> . . . . . <b>22</b>
<b>6.1</b>	<b>General</b> . . . . . <b>22</b>
<b>6.2</b>	<b>Pump Types</b> . . . . . <b>28</b>
<b>6.3</b>	<b>Pressure Casings</b> . . . . . <b>28</b>
<b>6.4</b>	<b>Nozzles and Pressure Casing Connections</b> . . . . . <b>31</b>
<b>6.5</b>	<b>External Nozzle Forces and Moments</b> . . . . . <b>34</b>
<b>6.6</b>	<b>Rotors</b> . . . . . <b>41</b>
<b>6.7</b>	<b>Wear Rings and Running Clearances</b> . . . . . <b>42</b>
<b>6.8</b>	<b>Mechanical Shaft Seals</b> . . . . . <b>44</b>
<b>6.9</b>	<b>Dynamics</b> . . . . . <b>48</b>
<b>6.10</b>	<b>Bearings and Bearing Housings</b> . . . . . <b>60</b>
<b>6.11</b>	<b>Lubrication</b> . . . . . <b>66</b>
<b>6.12</b>	<b>Materials</b> . . . . . <b>66</b>
<b>6.13</b>	<b>Nameplates and Rotation Arrows</b> . . . . . <b>71</b>
<b>7</b>	<b>Accessories</b> . . . . . <b>72</b>
<b>7.1</b>	<b>Drivers</b> . . . . . <b>72</b>
<b>7.2</b>	<b>Couplings</b> . . . . . <b>75</b>
<b>7.3</b>	<b>Guards</b> . . . . . <b>76</b>
<b>7.4</b>	<b>Baseplates</b> . . . . . <b>77</b>
<b>7.5</b>	<b>Instrumentation</b> . . . . . <b>81</b>
<b>7.6</b>	<b>Piping and Appurtenances</b> . . . . . <b>82</b>
<b>7.7</b>	<b>Special Tools</b> . . . . . <b>84</b>
<b>8</b>	<b>Inspection, Testing, and Preparation for Shipment</b> . . . . . <b>84</b>
<b>8.1</b>	<b>General</b> . . . . . <b>84</b>
<b>8.2</b>	<b>Inspection</b> . . . . . <b>85</b>
<b>8.3</b>	<b>Testing</b> . . . . . <b>87</b>
<b>8.4</b>	<b>Preparation for Shipment</b> . . . . . <b>95</b>
<b>9</b>	<b>Specific Pump Types</b> . . . . . <b>97</b>
<b>9.1</b>	<b>Single-stage Overhung Pumps</b> . . . . . <b>97</b>
<b>9.2</b>	<b>Between-bearings Pumps (Types BB1, BB2, BB3, and BB5)</b> . . . . . <b>98</b>
<b>9.3</b>	<b>Vertically Suspended Pumps (Types VS1 Through VS7)</b> . . . . . <b>103</b>
<b>10</b>	<b>Vendor's Data</b> . . . . . <b>110</b>

## Contents

	Page
<b>Annex A (normative) Specific Speed and Suction-specific Sped</b> .....	<b>111</b>
<b>Annex B (normative) Cooling Water Schematics</b> .....	<b>112</b>
<b>Annex C (normative) Hydraulic Power Recovery Turbines</b> .....	<b>120</b>
<b>Annex D (informative) Standard Baseplates</b> .....	<b>124</b>
<b>Annex E (informative) Inspector’s Checklist</b> .....	<b>126</b>
<b>Annex F (normative) Criteria for Piping Design</b> .....	<b>128</b>
<b>Annex G (informative) Materials Class Selection Guidance</b> .....	<b>142</b>
<b>Annex H (normative) Materials and Material Specifications for Pump Parts</b> .....	<b>144</b>
<b>Annex I (normative) Lateral Analysis</b> .....	<b>153</b>
<b>Annex J (normative) Determination of Residual Unbalance</b> .....	<b>159</b>
<b>Annex K (informative) Shaft Stiffness and Bearing System Life</b> .....	<b>165</b>
<b>Annex L (informative) Contract Documents and Engineering Design Data</b> .....	<b>171</b>
<b>Annex M (informative) Test Data Summary</b> .....	<b>185</b>
<b>Annex N (informative) Pump Data Sheets and Electronic Data Exchange</b> .....	<b>190</b>
<b>Annex O (informative) Special-purpose Centrifugal Pumps</b> .....	<b>213</b>
<b>Bibliography</b> .....	<b>218</b>
<b>Figures</b>	
<b>1 Pump Type OH1</b> .....	<b>15</b>
<b>2 Pump Type OH2</b> .....	<b>15</b>
<b>3 Pump Type OH3</b> .....	<b>15</b>
<b>4 Pump Type OH4</b> .....	<b>16</b>
<b>5 Pump Type OH5</b> .....	<b>16</b>
<b>6 Pump Type OH6</b> .....	<b>17</b>
<b>7 Pump Types BB1-A and BB1-B</b> .....	<b>17</b>
<b>8 Pump Type BB2</b> .....	<b>18</b>
<b>9 Pump Type BB3</b> .....	<b>18</b>
<b>10 Pump Type BB4</b> .....	<b>18</b>
<b>11 Pump Type BB5</b> .....	<b>19</b>
<b>12 Pump Type VS1</b> .....	<b>19</b>
<b>13 Pump Type VS2</b> .....	<b>19</b>
<b>14 Pump Type VS3</b> .....	<b>20</b>
<b>15 Pump Type VS4</b> .....	<b>20</b>
<b>16 Pump Type VS5</b> .....	<b>20</b>
<b>17 Pump Type VS6</b> .....	<b>21</b>
<b>18 Pump Type VS7</b> .....	<b>21</b>
<b>19 Machined Face Suitable for Gasket Containment if Using Cylindrical Threads</b> .....	<b>33</b>
<b>20 Typical Gusset Design</b> .....	<b>34</b>
<b>21 Coordinate System for the Forces and Moments in Table 5, Vertical In-line Pumps</b> .....	<b>37</b>
<b>22 Coordinate System for the Forces and Moments in Table 5, Horizontal Pumps with End Suction and Top Discharge Nozzles</b> .....	<b>38</b>

# Contents

Page

23	Coordinate System for the Forces and Moments in Table 5, Horizontal Pumps with Top Nozzles . . . .	39
24	Coordinate System for the Forces and Moments in Table 5, Horizontal Pumps with Side Suction and Side Discharge Nozzles . . . . .	40
25	Coordinate System for the Forces and Moments in Table 5, Vertically Suspended, Double-casing Pumps . . . . .	41
26	Chamber Diagrams . . . . .	45
27	Seal Chamber Concentricity . . . . .	47
28	Seal Chamber Face Runout . . . . .	47
29	Torsional Analysis Flow Chart . . . . .	49
30	Rotating Component Dimensions to Determine if Single-plane Balancing is Allowable . . . . .	52
31	Relationship Between Flow and Vibration . . . . .	54
32	Locations for Taking Vibration Readings on OH and BB Type Pumps . . . . .	55
33	Locations for Taking Vibration Readings on Vertically Suspended (VS) Pumps . . . . .	56
34	Locations for Taking Vibration Readings on Vertical In-line (OH3) and High-speed Integrally Geared (OH6) Pumps . . . . .	57
35	Bearing Housing Vibration Limits for Horizontal Pumps Running Above 3600 r/min or Absorbing More Than 400 hp (300 kW) per Stage . . . . .	60
36	Vertical Pump Drivers—Tolerances Required for the Driver Shaft and Base . . . . .	74
37	Flat Deck Plate with Sloping Gutter Drain . . . . .	77
38	Sloped Full Deck Plate . . . . .	78
39	Sloped Partial Deck Plate . . . . .	78
40	Location for Seal Flush Plan or Auxiliaries Mounted on the Baseplate . . . . .	79
41	Maximum Spacing Between Shaft Guide Bushings . . . . .	105
42	Thrust Bearing Arrangement with Two Couplings . . . . .	107
43	Optional Mounting for Vertically Suspended, Double-case Pumps (VS6 and VS7) with Sole Plate . . . . .	108
B.1	Symbols Used in Figures B.2 to B.7 . . . . .	112
B.2	Piping for Overhung Pumps—Plan A, Cooling to Bearing Housing . . . . .	112
B.3	Piping for Overhung Pumps—Plan K, Cooling to Bearing Housing with Parallel Flow to Seal Heat Exchanger . . . . .	113
B.4	Piping for Overhung Pumps—Plan M, Cooling to Seal Heat Exchanger . . . . .	114
B.5	Piping for Overhung Pumps—Plan M, Cooling to Seal Heat Exchanger and Reservoir . . . . .	115
B.6	Piping for Between-bearing Pumps—Plan A, Cooling to Bearing Housings . . . . .	116
B.7	Piping for Between-bearing Pumps—Plan K, Cooling to Bearing Housings with Parallel Flow to Seal Heat Exchangers . . . . .	117
B.8	Piping for Between-bearing Pumps—Plan M, Cooling to Seal Heat Exchangers . . . . .	118
B.9	Piping for Between-bearing Pumps—Plan M, Cooling to Seal Heat Exchangers and Reservoirs . . . . .	119
C.1	Typical HPRT Arrangements . . . . .	122
C.2	HPRT Test Performance Tolerances . . . . .	123
D.1	Standard Baseplate . . . . .	125
I.1	Damping Factor vs Frequency Ratio . . . . .	156
I.2	Typical Campbell Diagram . . . . .	157
J.1	Residual Unbalance Worksheet . . . . .	161
J.2	Residual Unbalance Worksheet—Polar Chart . . . . .	162
J.3	Example of Completed Residual Unbalance Worksheet . . . . .	163
J.4	Example of Completed Residual Unbalance Worksheet—Best-fit Circle for Residual Unbalance . . . . .	164
K.1	Simple Overhung Rotor . . . . .	165
K.2	Overhung Pump Shaft Flexibility Index vs Size Factor (SI Units) . . . . .	167
K.3	Overhung Pump Shaft Flexibility Index vs Size Factor (USC Units) . . . . .	168
L.1	Example Distribution Record . . . . .	177

## Contents

	Page
M.1 Test Data Summary Form . . . . .	185
M.2 Test Curve Format (USC Units) . . . . .	187
M.3 Example of Test Curve Format (SI Units) . . . . .	188
M.4 Test Points Shown on Typical Performance Curve . . . . .	189
N.1 USC Units Pump Process Data Sheet . . . . .	191
N.2 SI Units Pump Process Data Sheet . . . . .	198
N.3 Data List . . . . .	205
N.4 API Project Design Data Sheet . . . . .	212
Tables	
1 Pump Classification Type Identification . . . . .	14
2 Water-cooling System—Conditions on the Water Side . . . . .	26
3 Special Design Features of Particular Pump Types . . . . .	28
4 Casting Factors . . . . .	29
5 Nozzle Loadings . . . . .	35
6 Minimum Internal Running Clearances . . . . .	44
7 Standard Dimensions for Seal Chambers, Seal Gland Mounting, and Cartridge Mechanical Seal Sleeves . . . . .	46
8 Vibration Limits for Overhung and Between-bearings Pumps . . . . .	58
9 Vibration Limits for Vertically Suspended Pumps . . . . .	59
10 Bearing Selection . . . . .	61
11 Welding Requirements . . . . .	70
12 Power Ratings for Motor Drives . . . . .	73
13 Stiffness Test Acceptance Criteria . . . . .	81
14 Pressure Casing and Process Piping Material Inspection Requirements . . . . .	86
15 Materials Inspection Standards . . . . .	87
16 Performance Tolerances . . . . .	91
17 Shaft and Rotor Runout Requirements . . . . .	99
18 Decision Logic for Rotor Lateral Analysis . . . . .	100
19 Rotor Balance Requirements . . . . .	101
D.1 Dimensions of Standard Baseplates . . . . .	124
E.1 Inspector’s Checklist . . . . .	126
F.1 Nozzle Sizes and Location Coordinates for Example 1A . . . . .	132
F.2 Applied Nozzle Loadings for Example 1A . . . . .	132
F.3 Proposed Applied Nozzle Loadings for Example 2A . . . . .	134
F.4 Nozzle Sizes and Location Coordinates for Example 1B . . . . .	136
F.5 Applied Nozzle Loadings for Example 1B . . . . .	137
F.6 Proposed Applied Nozzle Loadings for Example 2B . . . . .	140
G.1 Materials Class Selection Guidance . . . . .	142
H.1 Material Classes for Pump Parts . . . . .	145
H.2 Material Specifications for Pump Parts . . . . .	147
H.3 Nonmetallic Wear Part Materials . . . . .	151
H.4 Piping Materials . . . . .	152
I.1 Rotor Lateral Analysis Logic Diagram . . . . .	153
L.1 Recommended Spare Parts . . . . .	176

## Introduction

It is necessary that users of this standard be aware that further or differing requirements can be needed for individual applications. This standard is not intended to inhibit a vendor from offering, or the purchaser from accepting, alternative equipment or engineering solutions for the individual application. This can be particularly appropriate where there is innovative or developing technology. Where an alternative is offered, it is necessary that the vendor identify any variations from this standard and provide details.

A bullet (•) at the beginning of a section or subsection indicates that either a decision is required or the purchaser is required to provide further information. It is necessary that this information be indicated on data sheets or stated in the inquiry or purchase order (see examples in Annex N).

This standard shows U.S. customary (USC) units with other units in parentheses for information.



# Centrifugal Pumps for Petroleum, Petrochemical, and Natural Gas Industries

## 1 Scope

This standard specifies requirements for centrifugal pumps, including pumps running in reverse as hydraulic power recovery turbines (HPRTs), for use in petroleum, petrochemical, and gas industry process services.

This standard is applicable to overhung pumps, between-bearings pumps, and vertically suspended pumps (see Table 1). Section 9 provides requirements applicable to specific types of pumps. All other sections of this standard are applicable to all pump types. Illustrations are provided of the various specific pump types and the designations assigned to each specific type.

Relevant industry operating experience suggests pumps produced to this standard are suitable for pumping liquids at conditions exceeding any one of the following:

- discharge pressure (gauge): 275 psi; 19.0 bar (1900 kPa);
- suction pressure (gauge): 75 psi; 5.0 bar (500 kPa);
- pumping temperature: 300 °F (150 °C);
- rotational speed: 3600 r/min;
- rated total head: 400 ft (120 m);
- impeller diameter, overhung pumps 13 in. (330 mm).

NOTE For sealless pumps, reference can be made to API 685.

## 2 Normative References

The following referenced documents are indispensable for the application of this document. For dated references, only the edition cited applies. For undated references, the latest edition of the referenced document (including any amendments) at the time of quotation applies.

API Standard 5L, *Line Pipe*

API Standard 541, *Form-wound Squirrel Cage Induction Motors—375 kW (500 Horsepower) and Larger*

API Standard 547, *General Purpose Form-wound Squirrel Cage Induction Motors—185 kW (250 hp) through 2240 kW (3000 hp)*

API Standard 611, *General-purpose Steam Turbines for Petroleum, Chemical, and Gas Industry Services*

ANSI <sup>1</sup>/API Standard 614, *Lubrication, Shaft-sealing and Oil-control Systems and Auxiliaries*

API Standard 670, *Machinery Protection Systems*

API Standard 671, *Special-purpose Couplings for Petroleum, Chemical, and Gas Industry Services*

API Standard 677, *General-purpose Gear Units for Petroleum, Chemical and Gas Industry Services*

---

<sup>1</sup> American National Standards Institute, 25 West 43rd Street, 4th Floor, New York, New York 10036, [www.ansi.org](http://www.ansi.org).

API Standard 682, *Pumps—Shaft Sealing Systems for Centrifugal and Rotary Pumps*

ANSI B11.19-2010, *Performance Criteria for Safeguarding*

ANSI/ABMA 7 <sup>2</sup>, *Shaft and Housing Fits for Metric Radial Ball and Roller Bearings (Except Tapered Roller Bearings) Conforming to Basic Boundary Plan*

ANSI/AGMA 9000 <sup>3</sup>, *Flexible Couplings—Potential Unbalance Classification*

ANSI/AGMA 9002, *Bores and Keyways for Flexible Couplings (Inch Series)*

ANSI/ASME B1.1 <sup>4</sup>, *Unified Inch Screw Threads (UN, UNR, and UNJ Thread Forms)*

ANSI/AWS D1.1, *Structural Welding Code—Steel*

ANSI/HI 14.6 <sup>5</sup>, *Rotodynamic Pumps for Hydraulic Performance Acceptance Tests*

ASME B1.13M, *Metric Screw Threads: M Profile*

ASME B16.5, *Pipe Flanges and Flanged Fittings: NPS 1/2 through NPS 24 Metric/Inch Standard*

ASME B16.11, *Forged Fittings, Socket-Welding and Threaded*

ASME B16.47, *Larger Diameter Steel Flanges NPS 26 Through NPS 60 Metric/Inch Standard*

ASME B18.18.2M, *Inspection and Quality Assurance for High-Volume Machine Assembly Fasteners*

ASME B31.3, *Process Piping*

ASME Boiler and Pressure Vessel Code (BPVC), Section V, *Nondestructive Examination*

ASME Boiler and Pressure Vessel Code (BPVC), Section VIII, *Rules for Construction of Pressure Vessels*

ASME Boiler and Pressure Vessel Code (BPVC), Section IX, *Welding, Brazing and Fusing Qualifications*

DIN 910 <sup>6</sup>, *Hexagon head screw plugs with collar—Cylindrical thread*

EN 287 <sup>7</sup>, *Qualification test of welders—Fusion welding—Steels*

EN 953, *Safety of machinery—Guards—General requirements for the design and construction of fixed and movable guards*

EN 1092-1, *Flanges and their joints—Circular flanges for pipes, valves, fittings and accessories, PN designated—Steel flanges*

EN 13445 (all parts), *Unfired pressure vessels*

EN 13445-4, *Unfired pressure vessels—Fabrication*

---

<sup>2</sup> American Bearing Manufacturers Association, 1001 N. Fairfax Street, Suite 500, Alexandria, VA 22314, [www.americanbearings.org](http://www.americanbearings.org).

<sup>3</sup> American Gear Manufacturers Association, 1001 N. Fairfax Street, Suite 500, Alexandria, VA 22314-1587, [www.agma.org](http://www.agma.org).

<sup>4</sup> ASM International, 9639 Kinsman Road, Materials Park, Ohio 44073, [www.asminternational.org](http://www.asminternational.org).

<sup>5</sup> Hydraulic Institute, 6 Campus Drive, First Floor North, Parsippany, New Jersey 07054-4406, [www.pumps.org](http://www.pumps.org).

<sup>6</sup> DIN Deutsches Institut für Normung e. V., Saatwinkler Damm 42/43, 13627 Berlin, Germany, [www.din.de](http://www.din.de).

<sup>7</sup> European Committee for Standardization (CEN-CENELEC), Avenue Marnix 17, B-1000 Brussels, Belgium, [www.cen.eu](http://www.cen.eu).

EN 13463-1, *Non-electrical equipment for use in potentially explosive atmospheres—Part 1: Basic method and requirements*

IEC 60034-1<sup>8</sup>, *Rotating electrical machines—Part 1: Rating and performance*

IEC 60034-2-1, *Rotating electrical machines—Part 2-1: Standard methods for determining losses and efficiency from tests (excluding machines for traction vehicles)*

IEC 60079 (all parts), *Explosive atmospheres*

IEEE 841<sup>9</sup>, *Petroleum and Chemical Industry—Premium-Efficiency, Severe Duty, Totally Enclosed Fan-Cooled (TEFC) Squirrel Cage Induction Motors—Up to and Including 370 kW (500 hp)*

ISO 228-1<sup>10</sup>, *Pipe threads where pressure-tight joints are not made on the threads—Part 1: Dimensions, tolerances and designation*

ISO 261, *ISO general purpose metric screw threads—General plan*

ISO 262, *ISO general purpose metric screw threads—Selected sizes for screws, bolts and nuts*

ISO 281:2007, *Rolling bearings—Dynamic load ratings and rating life*

ISO 286 (all parts), *System of limits and fits*

ISO 3117, *Tangential keys and keyways*

ISO 3183, *Petroleum and natural gas industries—Steel pipe for pipeline transportation systems*

ISO 4200, *Plain end steel tubes, welded and seamless—General tables of dimensions and masses per unit length*

ISO 5753 (all parts), *Rolling bearings—Internal clearance*

ISO 7005-1, *Pipe flanges—Part 1: Steel flanges for industrial and general service piping systems*

ISO 8501 (all parts), *Preparation of steel substrates before application of paints and related products—Visual assessment of surface cleanliness*

ISO 9606 (all parts), *Qualification testing of welders—Fusion welding*

ISO 9906, *Rotodynamic pumps—Hydraulic performance acceptance tests—Grades 1, 2 and 3*

ISO 10441, *Flexible couplings for mechanical power transmission—Special-purpose applications*

ISO 10721-2, *Steel structures—Part 2: Fabrication and erection*

ISO 11342, *Mechanical vibration—Methods and criteria for the mechanical balancing of flexible rotors*

ISO 14120, *Safety of machinery—Guards—General requirements for the design and construction of fixed and movable guards*

---

<sup>8</sup> International Electrotechnical Commission, 3 rue de Varembé, 1st Floor, PO Box 131, CH-1211 Geneva 20, Switzerland, [www.iec.ch](http://www.iec.ch).

<sup>9</sup> Institute of Electrical and Electronics Engineers, 445 Hoes Lane, Piscataway, New Jersey 08854, [www.ieee.org](http://www.ieee.org).

<sup>10</sup> International Organization for Standardization, 1, ch. de la Voie-Creuse, Case postale 56, CH-1211 Geneva 20, Switzerland, [www.iso.org](http://www.iso.org).

ISO 14691, *Petroleum, petrochemical and natural gas industries—Flexible couplings for mechanical power transmission—General-purpose applications*

ISO 15607, *Specification and qualification of welding procedures for metallic materials—General rules*  
ISO 15609 (all parts), *Specification and qualification of welding procedures for metallic materials—Welding procedure specification*

ISO 15649, *Petroleum and natural gas industries—Piping*

ISO 21940-11, *Mechanical vibration—Procedures and tolerances for rotors with rigid behaviour*

MSS SP-55<sup>11</sup>, *Quality Standard for Steel Castings for Valves, Flanges, Fittings and Other Piping Components—Visual Method for Evaluation of Surface Irregularities*

NACE MR0103<sup>12</sup>, *Materials Resistant to Sulfide Stress Cracking in Corrosive Petroleum Refining Environments*

NACE MR0175/ISO 15156 (all parts), *Petroleum and Natural Gas Industries—Materials for Use in H<sub>2</sub>S-containing Environments in Oil and Gas Production*

SSPC SP 6<sup>13</sup>, *Commercial Blast Cleaning*

### **3 Terms, Definitions, Acronyms, and Abbreviations**

#### **3.1 Terms and Definitions**

For the purposes of this document, the following definitions apply.

##### **3.1.1**

##### **allowable operating region**

Portion of a pump's hydraulic coverage over which the pump is allowed to operate, based on vibration within the upper limit of this standard or temperature rise or other limitation, specified by the manufacturer.

##### **3.1.2**

##### **axially split**

Joint split with the principal face parallel to the shaft centerline.

##### **3.1.3**

##### **barrel pump**

Horizontal pump of the double-casing type.

##### **3.1.4**

##### **barrier fluid**

Externally supplied fluid, at a pressure above the pump seal chamber pressure, introduced into an Arrangement 3 seal (pressurized dual mechanical seal) to completely isolate the pump process liquid from the environment.

---

<sup>11</sup> Manufacturers Standardization Society of the Valve and Fittings Industry, Inc., 127 Park Street, NE, Vienna, Virginia 22180-4602, [www.mss-hq.com](http://www.mss-hq.com).

<sup>12</sup> NACE International (formerly the National Association of Corrosion Engineers), 1440 South Creek Drive, Houston, Texas 77084-4906, [www.nace.org](http://www.nace.org).

<sup>13</sup> The Society for Protective Coatings, 40 24th Street, 6th Floor, Pittsburgh, Pennsylvania 15222, [www.sspc.org](http://www.sspc.org).

### **3.1.5 best efficiency point BEP**

Flowrate at which a pump achieves its highest efficiency at rated impeller diameter.

NOTE The BEP flowrate at maximum impeller diameter is used to determine pump specific speed and suction-specific speed. The BEP flowrate at reduced impeller diameters is similarly reduced from the value at maximum impeller diameter.

### **3.1.6 buffer fluid**

Externally supplied fluid, at a pressure lower than the pump seal chamber pressure, used as a lubricant and/or to provide a diluent in an Arrangement 2 seal (unpressurized dual mechanical seal).

### **3.1.7 cartridge-type element**

Assembly of all the parts of the pump except for the casing.

### **3.1.8 classically stiff**

Characterized by the first dry critical speed being above the pump's maximum continuous speed by the following:

- 20 % for rotors designed for wet running only;
- 30 % for rotors designed to be able to run dry.

### **3.1.9 critical speed**

Shaft rotational speed at which the rotor-bearing-support system is in a state of resonance.

### **3.1.10 datum elevation**

Elevation to which values of net positive suction head (NPSH) are referred (see 6.1.10).

See **net positive suction head** (3.1.33).

### **3.1.11 design**

Manufacturer's calculated parameter.

NOTE "Design" is a term that is used by the equipment manufacturer to describe various parameters, such as design power, design pressure, design temperature, or design speed. This term is used only by the equipment manufacturer and not in the purchaser's specifications.

### **3.1.12 double casing**

Type of pump construction in which the pressure casing is separate from the pumping elements contained in the casing.

NOTE Examples of pumping elements include diffuser, diaphragms, bowls, and volute inner casings.

### **3.1.13 drive-train component**

Item of the equipment used in series to drive the pump.

EXAMPLES Motor, gear, turbine, engine, fluid drive, clutch.

**3.1.14****dry critical speed**

Rotor critical speed calculated assuming that there are no liquid effects, that the rotor is supported only at its bearings, and that the bearings are of infinite stiffness.

**3.1.15****element****bundle**

Assembly of the rotor plus the internal stationary parts of a centrifugal pump.

**3.1.16****hydraulic power recovery turbine****HPRT**

Turbomachine designed to recover power from a fluid stream.

**3.1.17****hydrodynamic bearing**

Bearing that uses the principles of hydrodynamic lubrication.

**3.1.18****identical pump**

Pump of the same size, hydraulic design, number of stages, rotational speed, clearances, type of shaft seal (axial face or breakdown bushing), type of bearings, coupling mass, coupling overhang, and pumping the same liquid.

**3.1.19****informative**

Information only.

**3.1.20****maximum allowable temperature**

Maximum continuous temperature for which the manufacturer has designed the pump (or any part to which the term is referred) while pumping the specified liquid at the specified maximum operating pressure (does not include mechanical seal).

See **pressure casing** (3.1.46).

**3.1.21****maximum allowable working pressure****MAWP**

Maximum continuous pressure for which the manufacturer has designed the pump (or any part to which the term is referred) while pumping the specified liquid at the specified maximum operating temperature (does not include mechanical seal).

**3.1.22****maximum continuous speed**

Highest speed at which the manufacturer's design permits continuous operation.

**3.1.23****maximum discharge pressure**

Highest pressure produced by the pump with the furnished impeller(s) at any flow point from zero to maximum flow while operating at any of the continuous speeds that achieve the specified operating cases, with the liquid relative density (specific gravity) pumped and the maximum suction pressure provided for each respective operating case.

**3.1.24****maximum dynamic sealing pressure**

Highest pressure expected at the seals during any specified operating condition and during start-up and shutdown.

NOTE Both dynamic and static sealing pressures are important to selection of the mechanical seal. They are dependent on the pump suction pressure, operating point, and pump clearances. They are also affected by the pressure of the seal flush. This pressure is specified to the seal vendor. See API 682.

**3.1.25****maximum operating temperature**

Highest temperature of the pumped liquid, including upset conditions, to which the pump is exposed.

NOTE This temperature is specified to the seal vendor. See API 682.

**3.1.26****maximum static sealing pressure**

Highest pressure, excluding pressures encountered during hydrostatic testing, to which the seals can be subjected while the pump is shut down.

**3.1.27****maximum suction pressure**

Highest suction pressure to which the pump is subjected during operation (nontransient; does not include water hammer).

**3.1.28****minimum allowable speed**

Lowest speed (revolutions per minute) at which the manufacturer's design will permit continuous operation.

**3.1.29****minimum continuous stable flow**

Lowest flow at which the pump can continuously operate without exceeding the vibration limits imposed by this standard.

**3.1.30****minimum continuous thermal flow**

Lowest flow at which the pump can continuously operate without its operation being impaired by the temperature rise of the pumped liquid.

**3.1.31****minimum design metal temperature**

Lowest mean metal temperature (through the thickness) expected in service, including operation upsets, auto-refrigeration, and temperature of the surrounding environment, for which the equipment is designed.

**3.1.32****multistage pump**

Pump with three or more stages.

See 4.2.

**3.1.33****net positive suction head****NPSH**

Absolute inlet total head above the head equivalent to the vapor pressure referred to the NPSH datum plane.

NOTE NPSH is expressed in feet (meters) of head of the pumped liquid.

**3.1.34****net positive suction head available****NPSHA**

NPSH determined by the purchaser for the pumping system with the liquid at the rated flow and normal pumping temperature.

**3.1.35****net positive suction head required****NPSH3**

NPSH that results in a 3 % loss of head (first-stage head in a multistage pump) determined by the vendor by testing with water.

**3.1.36****nominal pipe size****NPS**

Designation, usually followed by a size designation number, corresponding approximately to the outside diameter (OD) of the pipe.

NOTE The NPS is expressed in inches.

**3.1.37****normal operating point**

Point at which the pump is expected to operate under normal process conditions.

**3.1.38****normal-wear part**

Part normally restored or replaced at each pump overhaul.

EXAMPLES Wear rings, inter-stage bushings, balancing device, throat bushing, seal faces, bearings, and gaskets.

**3.1.39****normative**

Required.

**3.1.40****observed**

Inspection or test where the purchaser is notified of the timing of the inspection or test and the inspection or test is performed as scheduled even if the purchaser or the purchaser's representative is not present.

**3.1.41****oil-mist lubrication**

Lubrication provided by oil mist produced by atomization and transported to the bearing housing, or housings, by compressed air.

**3.1.42****operating region**

Portion of a pump's hydraulic coverage over which the pump operates.

**3.1.43****overhung pump**

Pump whose impeller is supported by a cantilever shaft from its bearing assembly.

**3.1.44****owner**

Final recipient of the equipment who may delegate another agent as the purchaser of the equipment.



**3.1.45****positive material identification testing****PMI testing**

Any physical evaluation or test of a material to confirm that the material which has been or will be placed into service is consistent with the selected or specified alloy material designated by the owner. These evaluations or tests may provide either qualitative or quantitative information that is sufficient to verify the nominal alloy composition.

**3.1.45****preferred operating region**

Portion of a pump's hydraulic coverage over which the pump's vibration is within the base limit of this standard.

**3.1.46****pressure casing**

Composite of all stationary pressure-containing parts of the pump, including all nozzles, seal glands, seal chambers, and auxiliary connections but excluding the stationary and rotating members of mechanical seals.

NOTE The atmospheric side of the seal gland, the seal flush (piping) plan, auxiliary piping, and valves are not part of the pressure casing.

**3.1.47****purchaser**

Owner, or owner's agent, who issues the order and specification to the vendor.

**3.1.48****pure oil-mist lubrication**

(dry sump)

System in which the mist both lubricates the bearing(s) and purges the housing and there is no oil level in the sump.

**3.1.49****purge oil-mist lubrication**

(wet sump)

Systems in which the mist only purges the bearing housing.

**3.1.50****radially split**

Split with the principal joint perpendicular to the shaft centerline.

**3.1.51****rated operating point**

Point at which the vendor certifies that pump performance is within the tolerances stated in this standard.

NOTE Normally, the rated operating point is the specified operating point with the highest flow.

**3.1.52****relative density****specific gravity**

Property of a liquid expressed as the ratio of the liquid's density to that of water at standard temperature.

NOTE Standard temperature is 39.2 °F (4 °C).

**3.1.53****rotor**

Assembly of all the rotating parts of a centrifugal pump.

**3.1.54****similar pump**

Pump that is accepted, by agreement between purchaser and manufacturer as sufficiently similar to not require a lateral analysis, taking into account the factors listed for an **identical pump** (3.1.18).

**3.1.55****spark-resistant material**

Material that is not prone to generate impact sparks under conditions of use.

**3.1.56****specific speed**

$N_s$

Index relating flow, total head, and rotational speed for pumps of similar geometry.

**3.1.57****stage**

One impeller and associated diffuser or volute and return channel, if required.

**3.1.58****suction-specific speed**

$N_{ss}$  or  $S$

Index relating flow, NPSH3, and rotational speed for pumps of similar geometry.

**3.1.59****throat bushing**

Device that forms a restrictive close clearance around the sleeve (or shaft) between the seal or inner seal of a dual seal cartridge and the impeller.

**3.1.60****total indicator reading****total indicated runout****TIR**

Difference between the maximum and minimum readings of a dial indicator or similar device, monitoring a face or cylindrical surface, during one complete revolution of the monitored surface.

NOTE For a perfectly cylindrical surface, the indicator reading implies an eccentricity equal to half the reading. For a perfectly flat face, the indicator reading gives an out-of-perpendicularity equal to the reading. If the diameter in question is not perfectly cylindrical or flat, interpretation of the meaning of TIR is more complex and can represent ovality or lobing.

**3.1.61****trip speed**

⟨electric motor driver⟩

Electric motor driver-synchronous speed at maximum supply frequency.

**3.1.62****trip speed**

⟨variable-speed driver⟩

Variable-speed driver-speed at which the independent emergency overspeed device operates to shut down the driver.

**3.1.63****unit responsibility**

Obligation for coordinating the documentation, delivery, and technical aspects of all the equipment and all auxiliary systems included in the scope of the order.

**3.1.64****vendor**

Manufacturer or manufacturer's agent that supplies the equipment and is normally responsible for service support.

**3.1.65****vertical in-line pump**

Vertical-axis, single-stage overhung pump whose suction and discharge connections have a common centerline that intersects the shaft axis.

NOTE Types VS6 and VS7 are not considered in-line pumps.

**3.1.66****vertically suspended pump**

Vertical-axis pump whose liquid end is suspended from a column and mounting plate.

NOTE The pump's liquid end is usually submerged in the pumped liquid.

**3.1.67****wet critical speed**

Rotor critical speed calculated considering the additional support and damping produced by the action of the pumped liquid within internal running clearances at the operating conditions and allowing for stiffness and damping within the bearings.

**3.1.68****witnessed**

Inspection or test for which the purchaser is notified of the timing of the inspection or test and a hold is placed on the inspection or test until the purchaser or the purchaser's representative is in attendance.

**3.2 Acronyms and Abbreviations**

AFNOR	Association Française de Normalisation
AISI	American Iron and Steel Institute
ASD	adjustable speed drive
AUS	austenitic stainless steel
AVM	anti-vibration mount
BB	between-bearings
BEP	best efficiency point
CR	chrome
DBSE	distance between shaft ends
DEA	diethylamine
DGS	dry gas seal
DN	diameter nominal
EDE	electronic data exchange

FCC	fluid catalytic cracker
FEA	finite element analysis
FFT	fast Fourier transform
HPRT	hydraulic power recovery turbine
NPSHi	incipient net positive suction head
LNG	liquefied natural gas
MAWP	maximum allowable working pressure
MEA	monoethylamine
MEK	methylethylketone
MT	magnetic particle inspection
NDT	nondestructive testing
NPS	nominal pipe size
NPSH	net positive suction head
NPSHA	net positive suction head available
NPSH3	net positive suction head at 3 % head loss
$N_s$	specific speed
$N_{ss}$	suction-specific speed
OD	outside diameter
OH	overhung
PFA/CF	polyfluoroethylene with carbon fiber
PH	precipitation hardened
PMI	positive material identification
PRE	pitting resistance equivalency
PT	liquid penetrant inspection
PTFE	polytetrafluoroethylene
PWHT	postweld heat treatment
RMS	root mean square
RT	radiographic inspection

---

S	suction-specific speed
SDS	safety data sheet
SFI	shaft flexibility index
SG	specific gravity
SPL	sound pressure level
STL	carbon steel
TEA	triethylamine
TFE	tetrafluoroethylene
TIR	total indicator reading; total indicated runout
UN	Unified constant pitch (a thread form)
UNC	Unified National Coarse (a thread form)
UNS	Unified Numbering System (for metal and alloys)
UT	ultrasonic examination
VDDR	vendor drawing and data requirements
VFD	variable frequency drive
VI	visual inspection
VOC	volatile organic compound
VS	vertically suspended

## 4 General

### 4.1 Unit Responsibility

Unless otherwise specified, the pump vendor shall assume unit responsibility and shall assure that all subvendors comply with the requirements of this standard and all reference documents. The technical aspects to be considered by the vendor include, but are not limited to, such factors as the power requirements, speed, rotation, general arrangement, couplings, dynamics, lubrication, sealing system, material test reports, instrumentation, piping, conformance to specifications, and testing of components.

### 4.2 Classification and Designation

#### 4.2.1 Description of Codes

The pumps described in this standard are classified and designated by type codes, as shown in Table 1.

**Table 1—Pump Classification Type Identification**

Pump Type <sup>a</sup>		Description		Type Code	
Centrifugal pumps	Overhung	Flexibly coupled	Horizontal	Foot-mounted	OH1
				Centerline-supported	OH2
			Vertical in-line with bearing bracket	—	OH3
		Rigidly coupled	Vertical in-line	—	OH4
		Close-coupled	Vertical in-line	—	OH5
			High-speed integrally geared	—	OH6
	Between-bearings	1- and 2-stage	Axially split	Foot-mounted	BB1-A
			Axially split	Near-centerline mounted	BB1-B
			Radially split	Centerline supported	BB2
		Multistage	Axially split	Near-centerline supported	BB3
			Radially split	Single casing	BB4
				Double casing	BB5
	Vertically suspended	Single casing	Discharge through column	—	VS1
				—	VS2
				—	VS3
		Separate discharge pipe	Line shaft	VS4	
			Cantilever shaft	VS5	
Double casing		Radially split	—	VS6	
			—	VS7	

<sup>a</sup> Illustrations of the various types of pump are provided in 4.2.2.

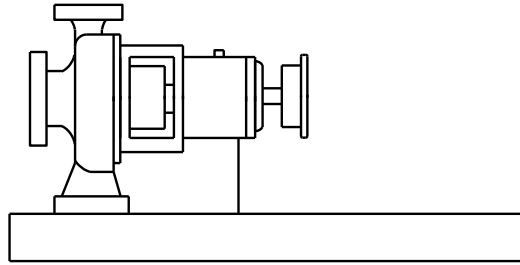
## 4.2.2 Pump Designations and Descriptions

### 4.2.2.1 General

The figures that follow in this section are generic and informative. They are not meant to show construction details or specific features.

#### 4.2.2.2 Pump Type OH1

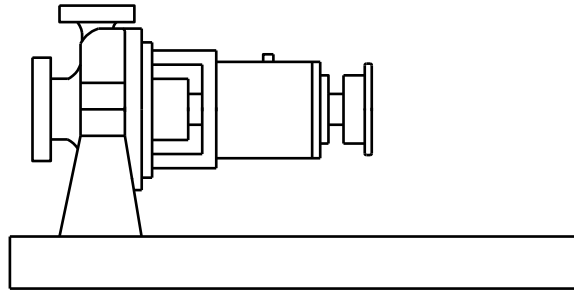
Foot-mounted, single-stage overhung pumps shall be designated pump type OH1 (Figure 1). (This type does not meet all the requirements of this standard; see Table 3.)



**Figure 1—Pump Type OH1**

#### **4.2.2.3 Pump Type OH2**

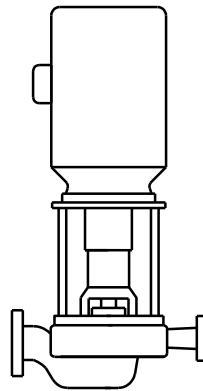
Centerline-mounted, single-stage overhung pumps shall be designated pump type OH2 (Figure 2). They have a single bearing housing to absorb all forces imposed upon the pump shaft and maintain rotor position during operation. The pumps are mounted on a baseplate and are flexibly coupled to their drivers.



**Figure 2—Pump Type OH2**

#### **4.2.2.4 Pump Type OH3**

Vertical, in-line, single-stage overhung pumps with separate bearing brackets shall be designated pump type OH3 (Figure 3). They have a bearing housing integral with the pump to absorb all pump loads. The driver is usually mounted on a support integral to the pump. The pumps and their drivers are flexibly coupled.



**Figure 3—Pump Type OH3**

#### 4.2.2.5 Pump Type OH4

Rigidly coupled, vertical, in-line, single-stage overhung pumps shall be designated pump type OH4 (Figure 4). Rigidly coupled pumps have their shaft rigidly coupled to the driver shaft. (This type does not meet all the requirements of this standard; see Table 3.)

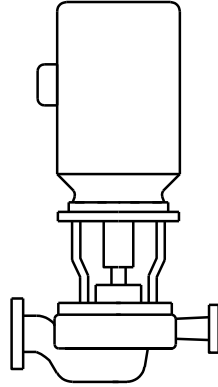


Figure 4—Pump Type OH4

#### 4.2.2.6 Pump Type OH5

Close-coupled, vertical, in-line, single-stage overhung pumps shall be designated pump type OH5 (Figure 5). Close-coupled pumps have their impellers mounted directly on the driver shaft. (This type does not meet all the requirements of this standard; see Table 3.)

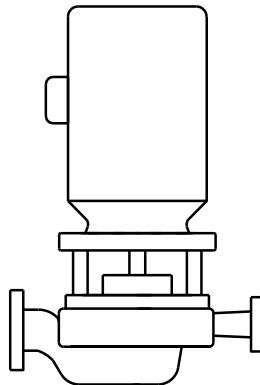


Figure 5—Pump Type OH5



#### 4.2.2.7 Pump Type OH6

High-speed, integral, gear-driven, single-stage overhung pumps shall be designated pump type OH6 (Figure 6). These pumps have a speed-increasing gearbox integral with the pump. The impeller is mounted directly to the gearbox output shaft. There is no coupling between the gearbox and pump; however, the gearbox is flexibly coupled to its driver. The pumps can be oriented vertically or horizontally.

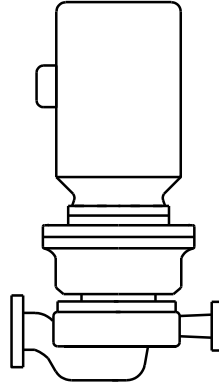
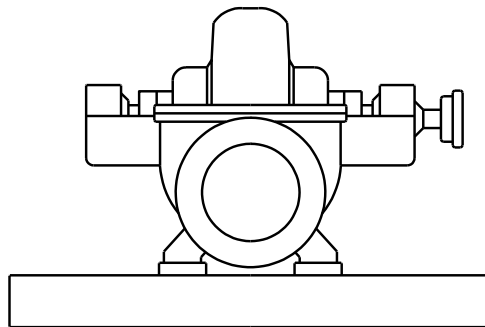


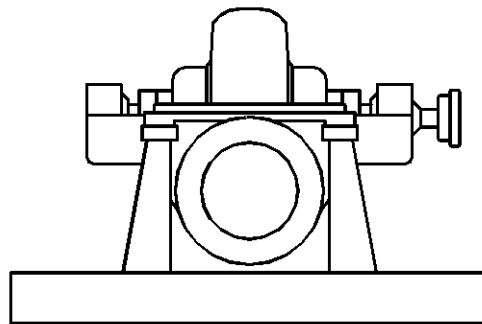
Figure 6—Pump Type OH6

#### 4.2.2.8 Pump Type BB1

Axially split, one- and two-stage, between-bearings pumps shall be designated pump type BB1 (Figure 7).



a) Pump Type BB1-A “Foot Mounted”



b) Pump Type BB1-B “Near-centerline Mounted”

Figure 7—Pump Types BB1-A and BB1-B

#### 4.2.2.9 Pump Type BB2

Radially split, one- and two-stage, between-bearings pumps shall be designated pump type BB2 (Figure 8).

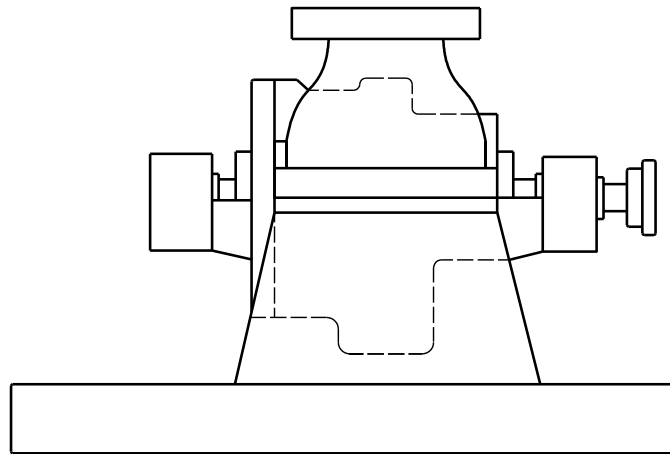


Figure 8—Pump Type BB2

#### 4.2.2.10 Pump Type BB3

Axially split, multistage, between-bearings pumps shall be designated pump type BB3 (Figure 9).

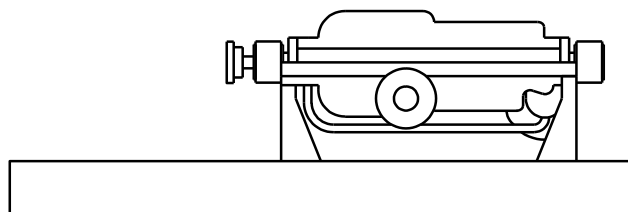


Figure 9—Pump Type BB3

#### 4.2.2.11 Pump Type BB4

Single-casing, radially split, multistage, between-bearings pumps shall be designated pump type BB4 (Figure 10). These pumps are also called ring-section pumps, segmental-ring pumps, or tie-rod pumps. These pumps have a potential leakage path between each segment. (This type does not meet all the requirements of this standard; see Table 3.)

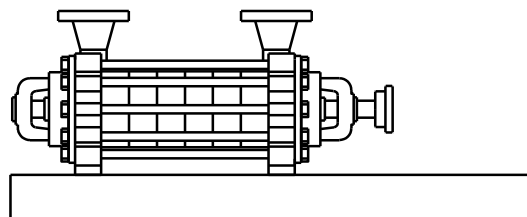


Figure 10—Pump Type BB4

#### 4.2.2.12 Pump Type BB5

Double-casing, radially split, multistage, between-bearings pumps (barrel pumps) shall be designated pump type BB5 (Figure 11).

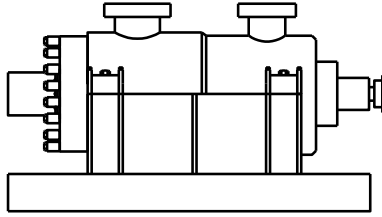


Figure 11—Pump Type BB5

#### 4.2.2.13 Pump Type VS1

Wet pit, vertically suspended, single-casing diffuser pumps with discharge through the column shall be designated pump type VS1 (Figure 12).



Figure 12—Pump Type VS1

#### 4.2.2.14 Pump Type VS2

Wet pit, vertically suspended, single-casing volute pumps with discharge through the column shall be designated pump type VS2 (Figure 13).

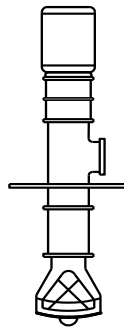


Figure 13—Pump Type VS2

#### 4.2.2.15 Pump Type VS3

Wet pit, vertically suspended, single-casing axial-flow pumps with discharge through the column shall be designated pump type VS3 (Figure 14).

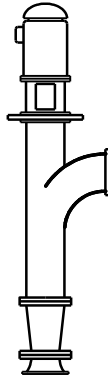


Figure 14—Pump Type VS3

#### 4.2.2.16 Pump Type VS4

Vertically suspended, single-casing, volute, line-shaft-driven sump pumps shall be designated pump type VS4 (Figure 15).

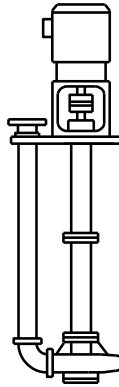


Figure 15—Pump Type VS4

#### 4.2.2.17 Pump Type VS5

Vertically suspended, cantilever sump pumps shall be designated pump type VS5 (Figure 16).

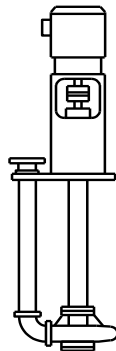


Figure 16—Pump Type VS5

#### 4.2.2.18 Pump Type VS6

Double-casing, diffuser, vertically suspended pumps shall be designated pump type VS6 (Figure 17).

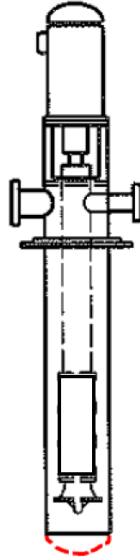


Figure 17—Pump Type VS6

#### 4.2.2.19 Pump Type VS7

Double-casing, volute or volute plus diffuser, vertically suspended pumps shall be designated pump type VS7 (Figure 18).

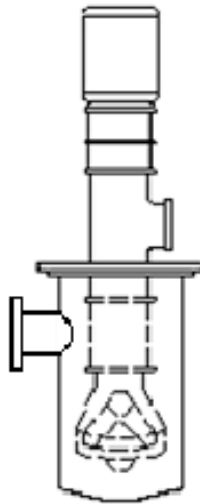


Figure 18—Pump Type VS7

## 5 Requirements

### 5.1 Units

- The purchaser shall specify whether data, drawings, and maintenance dimensions of pumps shall be in the U.S. customary (USC) or SI system of measurements. Use of a USC data sheet (see Figure N.1) indicates the USC system of measurements shall be used. Use of an SI data sheet (see Figure N.2) indicates the SI system of measurements shall be used.

### 5.2 Statutory Requirements

The purchaser and the vendor shall determine the measures to be taken to comply with any governmental codes, regulations, ordinances, or rules that are applicable to the equipment, its packaging and preservation. Equipment installed in the European Economic Area shall comply with all applicable European Union Directives.

NOTE The European Economic Area includes the countries of the European Union plus Norway, Iceland, and Liechtenstein.

### 5.3 Hierarchy of Requirements

**5.3.1** In case of conflict between this standard and the inquiry, the inquiry shall govern. At the time of the order, the purchase order shall govern.

**5.3.2** Where requirements specific to a particular pump type in Section 9 conflict with any other section, the requirements of Section 9 shall govern.

**5.3.3** The hierarchy of documents shall be specified.

NOTE Typical documents include company and industry specifications, meeting notes, and modifications to these documents.

## 6 Basic Design

### 6.1 General

#### 6.1.1 Equipment Reliability

- **6.1.1.1** Only equipment that is field proven, as defined by the Purchaser, is acceptable.

NOTE Purchasers can use their engineering judgment in determining what equipment is field proven. API 691 can provide guidance.

- **6.1.1.2** If specified, the vendor shall provide the documentation to demonstrate that all equipment proposed qualifies as field proven.

**6.1.1.3** In the event no such equipment is available, the vendor shall submit an explanation of how their proposed equipment can be considered field proven.

NOTE A possible explanation can be that all components comprising the assembled machine satisfy the field proven definition.

**6.1.2** The vendor shall advise in the proposal any component designed for a finite life.

- **6.1.3** The purchaser shall specify the operating conditions (including any upset, cleaning, seasonal, etc.), the liquid properties, preferred materials, site conditions, and utility conditions, including all data shown on the process data sheet (Annex N). If the application is a HPRT (pump running in reverse or radial inflow liquid

machine), the purchaser shall specify the maximum inlet pressure on the process data sheet (Annex N). HPRTs shall comply with Annex C.

- **6.1.3.1** The purchaser shall specify if equipment will be supplied in accordance with API 691.

NOTE 1 Operating companies can invoke API 691 for certain high-risk applications involving:

- a) special-purpose pumps (refer to Annex O);
- b) critical service pumps and/or;
- c) pumps identified in HAZOP, Process Safety Management (PSM) studies, etc. and internal company risk assessment.

NOTE 2 Both the API 610 data sheets (Annex N) and API 691 data sheets can be issued jointly to define all applicable requirements.

- **6.1.3.2** If API 691 is specified, the vendor shall identify all machinery components that are not "Field Qualified" per API 691 (First Edition), Section 4.3.2 and Table 1.

**6.1.4** The equipment shall be capable of operation at the normal and rated operating points and any other anticipated operating conditions specified by the purchaser.

**6.1.5** Pumps shall be capable of at least a 5 % head increase at rated flow by replacement of the impeller(s) with one(s) of larger diameter or different hydraulic design, variable-speed capability, or use of a blank stage.

NOTE This requirement is intended to prevent a change in selection caused by refinement of hydraulic requirements after the pump has been purchased. It is not intended to accommodate future unit expansion. If there is a future operating requirement, it is specified separately and considered in selection.

**6.1.6** Pumps shall be capable of operating at least up to the maximum continuous speed. The maximum continuous speed shall be

- a) equal to the speed corresponding to the synchronous speed at maximum supply frequency for electrical motors,
- b) at least 105 % of rated speed for variable-speed pumps and any fixed-speed pump sparing or spared by a pump whose driver is capable of exceeding rated speed.

**6.1.7** Variable-speed pumps shall be designed for excursions to trip speed without damage.

**6.1.8** The conditions in the seal chamber required to maintain a stable fluid film at the seal faces shall be agreed upon by the pump vendor and seal manufacturer, approved by the purchaser, and stated on the pump data sheet. The necessary parameters include temperature, pressure, and flow, as well as provisions for assuring the adequacy of the design for sealing against atmospheric pressure when pumps are idle in vacuum service. During operation, the seal chamber pressure shall be at least a gauge pressure of 5 psi (35 kPa); see API 682.

NOTE Provision for sealing against atmospheric pressure in vacuum service is especially important when handling liquids near their vapor pressure (such as liquefied petroleum gases).

**6.1.9** The vendor shall specify the net positive suction head at 3 % head loss (NPSH3) based on water at a temperature of less than 130 °F (55 °C) at the rated flow and rated speed. A reduction or correction factor for liquids other than water (such as hydrocarbons) shall not be applied. The datum elevations for NPSH3 shall be the shaft centerline for horizontal pumps and the impeller suction eye for vertical in-line pumps and vertically suspended pumps.

NOTE 1 NPSH3 means that during operation with NPSH available (NPSHA) equal to NPSH3, the extent of cavitation within the impeller is sufficient to cause a 3 % loss of head. NPSH3 is a performance characteristic of the first-stage impeller.

NOTE 2 The datum elevations defined above for NPSH3 are in accordance with HI 14.6 (ISO 9906). NPSH3 values are provided by the vendor and if specified can be demonstrated by test.

- **6.1.10** The purchaser shall specify the NPSHA based on system conditions at the rated flow. The datum elevations for NPSHA shall be the estimated shaft centerlines for horizontal pumps and the estimated suction-nozzle centerlines for vertical pumps.

NOTE 1 At the beginning of a project, actual elevations of pump shaft and suction nozzle centerlines are estimates based on preliminary information. As the project develops, the final pump geometry is provided by the vendor and the purchaser designs the final pump installation. At that point, the final datum elevations for NPSHA can be determined.

NOTE 2 The purchaser determines the final datum elevation for NPSHA based on the purchased pump and the final installation design. The final NPSHA can then be calculated based on the final datum elevation. The purchaser can record the final NPSHA value.

NOTE 3 The NPSH margin is calculated as the difference of the final NPSHA and the NPSH3 at the common datum defined by HI 14.6 (ISO 9906). The purchaser can record the final NPSH margin value.

NOTE 4 The purchaser considers an appropriate NPSH margin. Acceptable minimum NPSH margins vary by pump type and service. In establishing the NPSH margin, the purchaser and the vendor recognize the relationship between minimum continuous stable flow and the pump's suction-specific speed. In general, minimum continuous stable flow increases as suction-specific speed increases. However, other factors, such as the pump's energy level and hydraulic design, the pumped liquid, and the NPSH margin, also affect the pump's ability to operate satisfactorily over a wide flow range. Pump design that addresses low-flow operation is an evolving technology, and selection of suction-specific speed values and NPSH margins can take into account current industry and vendor experience.

- **6.1.11** The pump suction-specific speed shall be calculated in accordance with Annex A. If the purchaser specifies a suction-specific speed limit, the pump shall have a calculated suction-specific speed not greater than that specified limit.

**6.1.12** Pumps that handle liquids more viscous than water shall have their water performance corrected in accordance with HI 9.6.7. Correction factors used for viscous liquid shall be submitted with both sales proposal curves and final test curves.

- **6.1.13** If parallel operation is specified and the pumps are not individually flow controlled, the following is required:
  - a) the pump head curves shall be continuously rising to shutoff;
  - b) the head rise from rated point to shutoff shall be at least 10 %;
  - c) the head values of the pumps at any given flow within the preferred operating range shall be within 3 % of each other for pumps larger than 3 in. (80 mm) discharge.

NOTE The above requirements are not necessary for pumps with individual adjustable speed drives (ASDs) controlled by individual flow measurements.

**6.1.14** If a discharge orifice is used as a means of providing a continuously rising head curve, this shall be stated in the proposal.

- **6.1.15** If specified, pump head curves shall be continuously rising from rated point to shutoff.

NOTE Pumps with a continuously rising head curve are preferred for all applications, but this is not possible with all pump types. Head curve shape is dependent on several factors specific to the pumps hydraulic design.

**6.1.16** Pumps shall have a preferred operating region of 70 % to 120 % of BEP flowrate of the pump as furnished. Rated flow shall be within the region of 80 % to 110 % of the BEP flowrate of the pump as furnished. The "end of curve flow" is defined as 120 % of the BEP flowrate.



NOTE 1 Setting limits for the preferred operating region and the location of rated flow are not intended to lead to the development of additional small pump sizes or preclude the use of high-specific-speed pumps. Small pumps that are known to operate satisfactorily at flows lower than the 70 % limit specified above and high-specific-speed pumps that can have preferred operating regions narrower than the region specified above can be offered, where appropriate.

NOTE 2 "BEP flowrate of the pump as furnished" refers to the BEP of the pump with the impeller diameter selected to develop rated head at rated flow.

NOTE 3 For allowable operating region, see 3.1.1.

NOTE 4 Generally, pumps with BEP flowrates between the rated and normal points require less energy to operate than pumps with BEP flowrates greater than the specified rated point.

**6.1.17** The pump specific speed and the pump suction-specific speed shall be calculated in accordance with Annex A.

**6.1.18** For pumps equipped with ASDs, the vendor shall determine the minimum allowable speed of the equipment and record the value.

- **6.1.19** The vendor shall provide maximum expected A-weighted sound pressure level (SPL) for the equipment.

**6.1.19.1** Control of the SPL of all equipment furnished shall be a joint effort of the purchaser and the vendor who has unit responsibility.

**6.1.19.2** If specified, the equipment furnished by the vendor shall conform to a maximum allowable SPL specified by the purchaser.

NOTE ISO 3740 [7], ISO 3744 [8], and ISO 3746 [9] can be consulted for guidance.

**6.1.20** For pumps developing head greater than 650 ft (200 m) per stage and absorbing more than 300 hp (225 kW) per stage, the radial clearance between the diffuser vane or volute tongue (cutwater) and the periphery of the impeller vane shall be at least 3 % of the maximum impeller vane-tip radius for diffuser designs and at least 6 % of the maximum blade-tip radius for volute designs.

NOTE 1 The maximum impeller vane-tip radius is the radius of the largest impeller that can be used within the pump casing (see 6.1.6). The clearance,  $P$ , expressed as a percentage, is calculated using Equation (1):

$$P = 100(R_2 - R_1) / R_1 \quad (1)$$

where

$R_2$  is the radius of volute or diffuser inlet tip;

$R_1$  is the maximum impeller blade tip radius.

NOTE 2 It is common practice for the impellers of pumps covered by this section to be modified after initial test to correct hydraulic performance by underfilling, overfilling, or "V"-cutting. Any such modifications are documented in accordance with L.3.2.2.

**6.1.21** Pumps operating above 3600 r/min and absorbing more than 400 hp (300 kW) per stage can require even larger running clearances and other special construction features. For these pumps, specific requirements shall be agreed upon by the purchaser and the vendor, considering actual operating experience with the specific pump types.

- **6.1.22** The need for bearing housing cooling shall be determined by the vendor, and the method shall be agreed upon by the purchaser. Fan cooling for the bearing housing shall be the first choice. If fan cooling is inadequate, one of the plans in Annex B shall be selected. The cooling system shall be suitable for operation

with the coolant type, pressure and temperature specified by the purchaser. The vendor shall specify the required flow.

**NOTE** To avoid condensation in the bearing housing, the minimum temperature of the cooling-liquid at the inlet to bearing housing is maintained above the ambient air temperature.

**6.1.23** Jackets, if provided, shall have clean-out connections arranged so that the entire passageway can be mechanically cleaned, flushed, and drained.

**6.1.24** Jacket systems, if provided, shall be designed to prevent the process stream from leaking into the jacket or the heat transfer medium from leaking into the process. Jacket passages shall not open into casing joints.

**6.1.25** Unless otherwise specified, water-cooling systems shall be designed for the conditions on the water side as given in Table 2.

**6.1.26** Provisions shall be made for complete venting and draining of cooling-water systems.

**6.1.27** The vendor shall notify the purchaser if the criteria for minimum temperature rise and velocity over heat exchange surfaces result in a conflict. The criterion for velocity over heat exchange surfaces is intended to minimize water-side fouling; the criterion for minimum temperature rise is intended to minimize the use of cooling water. If such a conflict exists, the purchaser shall approve the final selection.

**Table 2—Water-cooling Systems—Conditions on the Water Side**

Parameter	USC and Other Units	SI Units
Velocity over heat exchange surfaces	5 ft/s to 8 ft/s	1.5 m/s to 2.5 m/s
Maximum allowable working pressure (MAWP), gauge shall be as a minimum	100 psi; 7 bar	700 kPa
Test pressure (> 1.5 MAWP), gauge	150 psi; 10.5 bar	1050 kPa
Maximum pressure drop	15 psi, 1 bar	100 kPa
Maximum inlet temperature	90 °F	30 °C
Maximum outlet temperature	120 °F	50 °C
Maximum temperature rise	30 °F	20 °C
Fouling factor on water side	0.002 h-ft <sup>2</sup> -°R/Btu	0.35 m <sup>2</sup> K/kW
Shell corrosion allowance (not for tubes)	0.125 in.	3.0 mm

**6.1.28** The arrangement of the equipment, including piping and auxiliaries, shall be developed jointly by the purchaser and the vendor. The arrangement shall provide sufficient clearance between equipment and piping and auxiliaries to allow safe access for operation and maintenance. (For OH2 type pumps, see Figure 40.)

### 6.1.29 Electrical Classification

**6.1.29.1** Locations for installed equipment can be classified as hazardous electrical areas or they can be unclassified. An unclassified area is considered nonhazardous; therefore, motors, electrical instrumentation, equipment, components, and electrical installations for unclassified areas are not governed by hazardous area electrical codes.

**6.1.29.2** If an installation location is classified as hazardous, motors, electrical instrumentation, equipment, components, and electrical installations shall be suitable for the hazardous electrical area classification designation as specified.

**6.1.29.3** All applicable electrical codes shall be specified. Local electrical codes that apply shall be provided by the purchaser upon request.

**6.1.30** Oil reservoirs and housings that enclose moving lubricated parts, such as bearings, shaft seals, highly polished parts, instruments and control elements, shall be designed to minimize contamination by moisture, dust, and other foreign matter during periods of operation and idleness.

**6.1.31** All equipment shall be designed to permit rapid and economical maintenance. Major parts, such as casing components and bearing housings, shall be designed and manufactured to ensure accurate alignment on reassembly. This can be accomplished by the use of shouldering, dowels, or keys.

**6.1.32** Except for vertically suspended pumps and integrally geared pumps, pumps shall be designed to permit removal of the rotor or inner element without disconnecting the suction or discharge piping or moving the driver.

**6.1.33** The pump and its driver shall perform on their test stands and on their permanent foundation within the vibration acceptance criteria specified in 6.9.4. After installation in accordance with the vendor's requirements, the performance of the pump and driver as a combined unit shall be the joint responsibility of the purchaser and the vendor who has unit responsibility.

- **6.1.34** Many factors can adversely affect site performance. These factors include such items as piping loads, alignment at operating conditions, supporting structure, handling during shipment, and handling and assembly at the site. If specified, the vendor's representative shall witness:

- a) a check of the piping alignment performed by unfastening the major flanged connections of the equipment;
- b) the initial shaft alignment check at ambient conditions;
- c) shaft alignment at operating temperature, i.e. hot alignment check.

NOTE Refer to API 686 for basic guidelines for conducting piping alignments, shaft cold alignments, and shaft hot alignments.

**6.1.35** Spare and all replacement parts for the pump and all furnished auxiliaries shall, as a minimum, meet all the criteria of this standard.

**6.1.36** Equipment, including all auxiliaries, shall be designed for outdoor installation and the specified site environmental conditions. The vendor shall advise of any equipment protection required for the jobsite location (i.e. winterization for low ambient temperatures, or protection against unusual humidity, dusty or corrosive conditions, etc.).

### **6.1.37 Bolting and Threads**

**6.1.37.1** The details of threading shall conform to ASME B1.1, ASME B1.13M, or ISO 261. The vendor shall advise the type of bolting used on the pump.

**6.1.37.2** If ASME B1.1 threads have been specified, the thread series shall be the varying-pitch series UNC for sizes up to 1 in. and 8 UN for sizes greater than 1 in. All threads shall be Class 2 or 3.

NOTE Coatings on pressure casing bolting are sometimes not practical because they can alter the class of the threads. This alteration can affect tightening requirements of the bolting.

**6.1.37.3** If ISO 261 and ISO 262 have been specified, the thread series shall be coarse. Threads shall be Class 6g for bolting and studs and Class 6H for nuts.

**6.1.37.4** Commercial fasteners shall be manufactured in accordance with the requirements of ASME B18.18.2M or shall be procured from distributors having quality plans in accordance with ASME B18.18.2M.

**6.1.38** Adequate clearance shall be provided at all bolting locations to permit the use of socket or box wrenches.

**6.1.39** Unless otherwise specified or agreed, studs shall be supplied on all main casing joints, and all other joints and connections shall be supplied with external hexagon-head bolting.

**6.1.40** Fasteners (excluding washers and headless set-screws) shall have the material grade and manufacturer's identification symbols applied to one end of studs  $\frac{3}{8}$  in. (10 mm) in diameter and larger and to the heads of bolts  $\frac{1}{4}$  in. (6 mm) in diameter and larger. If the available area is inadequate, the grade symbol may be marked on one end and the manufacturer's identification symbol marked on the other end. Studs shall be marked on the exposed end.

NOTE A set-screw is a headless screw with a hexagonal socket in one end.

**6.1.41** Pressure casing fasteners shall be not less than 0.5 in. (12 mm) diameter.

## 6.2 Pump Types

- **6.2.1** The pump types listed in Table 3 have special design features that prevent them from fully complying with this standard. These pumps shall be offered only if specified by the purchaser and if the manufacturer has proven experience for the specific application. Table 3 lists the features requiring special consideration for these pump types and gives in parentheses the relevant subsection(s) of this standard.

**Table 3—Special Design Features of Particular Pump Types**

Pump Type	Features Requiring Special Consideration
Horizontal foot-mounted overhung, OH1	a) Pressure rating (6.3.6) b) Casing support (6.3.14)
Rigidly coupled vertical in-line, OH4	a) Motor construction (7.1.8, 7.1.9) b) Rotor stiffness (6.9.1.3) c) Product-lubricated guide bearing (6.10.1.1) d) Shaft runout at seal (6.6.9, 6.8.5)
Close-coupled (impeller mounted on motor shaft), OH5	a) Motor construction (7.1.8, 7.1.9) b) Motor bearing and winding temperature at high pumping temperatures c) Seal removal (6.8.2)
Two-stage overhung	a) Rotor stiffness (6.9.1.3)
Double-suction overhung	a) Rotor stiffness (6.9.1.3)
Ring-section casing (multistage), BB4	a) Pressure containment (6.3.3, 6.3.13) b) Dismantling (6.1.31)
Built-in mechanical seal (no separable seal gland)	a) Seal removal (6.8.2)

- **6.2.2** If the pump is deemed by the purchaser to be a special-purpose pump, refer to Annex O for guidance.

## 6.3 Pressure Casings

**6.3.1** The maximum discharge pressure shall be the highest of the maximum discharge pressures as calculated for all of the operating cases. The calculations shall be based on the maximum differential pressure that the pump is able to develop when operating with the furnished impeller(s) at the continuous speed and

when pumping the relative density (specific gravity) from respective operating cases, plus the maximum suction pressure for respective operating cases. The pump vendor shall calculate the maximum discharge pressure for the pump and shall record that value.

- **6.3.2** If specified, the maximum discharge pressure shall be increased by the additional differential pressure developed during one or more of the following operating circumstances:
  - a) operation with temporary liquid of relative density higher than those specified in the liquid characteristics section of the pump data sheet (e.g. post-construction pipe cleaning liquid);
  - b) installation of an impeller of the maximum diameter and/or number of stages that the pump can accommodate;
  - c) operation to trip or maximum speed of the driver.

**NOTE** The purchaser will assess the likelihood of the occurrence of Items a), b), and/or c) before specifying any of them. Momentary differential pressure excursions are sometimes considered covered by the hydrostatic test margin (see 8.3.2.2).

**6.3.3** The pressure casing shall be designed to

- a) operate without leakage or internal contact between rotating and stationary components while subject simultaneously to the MAWP (and maximum operating temperature) and the worst-case combination of twice the allowable nozzle loads of Table 5 applied through each nozzle;
- b) withstand the hydrostatic test (see 8.3.2).

**NOTE** The twice-nozzle-load requirement is a pressure casing design criterion. Allowable nozzle loads for piping designers are the values given in Table 5, which, in addition to pressure casing design, include other factors that affect allowable nozzle loads, such as casing support and baseplate stiffness.

**6.3.4** For pressure casing components, the tensile stress used in the design shall not exceed 0.25 times the minimum ultimate tensile strength or 0.67 times the minimum yield strength for that material, whichever is lower, with MAWP across the full range of specified operating temperatures. For castings, the minimum ultimate tensile strength and minimum yield strength for that material shall be multiplied by the appropriate casting factor, as shown in Table 4.

**Table 4—Casting Factors**

Type of Nondestructive Examination	Casting Factor
Visual, magnetic particle, and/or liquid penetrant	0.8
Spot radiography	0.9
Ultrasonic	0.9
Full radiography	1.0

**6.3.5** The vendor's proposal shall state the source of the material properties from those listed in Table H.2 (i.e. ASTM, ISO, UNS, EN, JIS), as well as the casting factors applied. National material standards other than those listed in Table H.2 may be used with specific purchaser approval.

**NOTE 1** In general, the criteria in 6.3.3 result in deflection (strain) being the determining consideration in the design of pump casings with respect to pressure retention and nozzle loads. Ultimate tensile or yield strength is seldom the limiting factor.

**NOTE 2** For bolting, the allowable tensile stress is used to determine the total bolting area based on hydrostatic load or gasket preload. It is recognized that to provide the initial load required to obtain a reliable bolted joint under cyclic loading, it is necessary that the bolting be tightened to produce a tensile stress higher than the design tensile stress. Usual values are in the range of 0.7 to 0.9 times yield.

**6.3.6** Except as noted in 6.3.8, the MAWP shall be at least the maximum discharge pressure (see 6.3.1 and 6.3.2) plus 10 % of the maximum differential pressure and shall not be less than:

- a) for pump types BB1, VS1, VS2, VS3, VS4, VS5, VS6, and VS7: a pressure rating equal to that of an ASME B16.5, Class 150 steel flange of material grade corresponding to that of the pressure casing;

NOTE For the purpose of this provision, ISO 7005-1 PN20 and EN 1759-1, Class 150 are equivalent to ASME B16.5, Class 150.

- b) for all other pump types: a gauge pressure rating equal to at least 600 psi (4 MPa; 40 bar) at 100 °F (38 °C).

**6.3.7** The pump-seal chamber and seal gland shall have a pressure-temperature rating at least equal to the MAWP and temperature of the pump casing to which it is attached, in accordance with API 682, Fourth Edition, Section 3.1.52.

- **6.3.8** If specified, pump types VS6, VS7, OH6, BB3, BB4, and BB5 may be designed for dual pressure ratings. The purchaser should consider installation of relief valves on the suction side of such installations. If specified, suction regions shall be designed for the same MAWP as the discharge section.
- **6.3.9** Unless otherwise specified, MAWP of pressure casings for HPRTs shall be at least equal to the maximum inlet pressure or the minimum MAWP values specified by 6.3.6, whichever is greater. If a relief valve is provided on the downstream piping before the first block valve, the MAWP of the low-pressure region of the casing shall be at least equal to the specified relief valve set point.
- **6.3.10** The pressure casing shall be designed with a corrosion allowance to meet the requirements of 6.1.1. Unless otherwise specified, the minimum corrosion allowance shall be 0.12 in. (3 mm).

NOTE The vendor is encouraged to propose alternative corrosion allowances for consideration if materials of construction with superior corrosion resistance are employed without affecting safety and reliability.

**6.3.11** The inner casing of double-casing pumps shall be designed to withstand the maximum differential pressure or 50 psi (350 kPa, 3.5 bar), whichever is greater.

**6.3.12** Unless otherwise specified, pumps with radially split casings are required in services for any of the following operating conditions:

- a) pumping temperature of 400 °F (200 °C) or higher;
- b) liquids with a relative density of less than 0.7 at the specified pumping temperature;
- c) liquids at a rated discharge gauge pressure above 1450 psi (10 MPa, 100 bar);
- d) liquid temperature transients greater than 100 °F (55 °C);
- e) liquid temperature transients that cause casing metal temperature change rates greater than 5 °F (3 °C) per minute.

NOTE 1 Axially split casings have been used successfully beyond the limits given above, particularly for pipeline applications at higher pressure and with lower relative density (specific gravity). The success of such applications depends on the margin between design pressure and rated pressure, the manufacturer's experience with similar applications, the design and manufacture of the split joint, and the user's ability to correctly remake the split joint in the field. The purchaser usually considers these factors before specifying an axially split casing for conditions beyond the above limits.

NOTE 2 Items d) and e) are for operating cases where a pump can be "shocked" if pumping liquids with different temperatures. These temperature transients tend to occur during start-up for a pump that is not warmed-up or cooled down ahead of the introduction of process liquid. Item d) is addressing step-changes in pumped liquid temperature, and Item e) addresses a slower rate of change in temperature but still exceeds the casing material temperature change rate.

- **6.3.13** Radially split casings shall have metal-to-metal fits, with confined controlled-compression gaskets, such as an O-ring or a spiral-wound type. Gaskets other than spiral-wound may be proposed and furnished if proven suitable for service and approved by the purchaser. Radially split pressure casing joints and bolting shall be designed to seat a spiral-wound gasket (see 9.3.2.3 for VS type pumps).

NOTE Table H.1 shows only spiral-wound gaskets for casing joints. Spiral-wound gaskets are generally preferred because they are perceived by users to have had better availability, are more conducive to material identification, have a broader chemical compatibility and temperature range, contact a wider sealing surface (are less susceptible to leakage because of sealing surface irregularities), and are easier to handle and store than O-rings. API 682 specifically requires O-ring gaskets on low-temperature [ $< 350$  °F ( $175$  °C)] pressure-seal gland plates.

**6.3.14** Centerline-supported pump casings shall be used for all horizontal pumps except as allowed in 9.2.1.2.

**6.3.15** O-ring sealing surfaces, including all grooves and bores, shall have a maximum surface roughness average value,  $R_a$ , of  $63$   $\mu\text{in.}$  ( $1.6$   $\mu\text{m}$ ) for static O-rings and  $32$   $\mu\text{in.}$  ( $0.8$   $\mu\text{m}$ ) for the surface against which dynamic O-rings slide. Bores shall have a minimum  $0.12$  in. ( $3$  mm) radius or a minimum  $0.06$  in. ( $1.5$  mm) chamfered lead-in for static O-rings and a minimum  $0.08$  in. ( $2$  mm) chamfered lead-in for dynamic O-rings. Chamfers shall have a maximum angle of  $30^\circ$ .

**6.3.16** Spiral-wound gasket sealing surfaces shall have a maximum surface roughness average value,  $R_a$ , of  $250$   $\mu\text{in}$  ( $6.4$   $\mu\text{m}$ ) and minimum surface roughness average value of  $125$   $\mu\text{in}$  ( $3.2$   $\mu\text{m}$ ).

**6.3.17** Jackscrews shall be provided to facilitate disassembly of the casing. One of the contacting faces shall be relieved (counter-bored or recessed) to prevent a leaking joint or an improper fit caused by marring of the face.

**6.3.18** The use of threaded holes in pressure parts shall be minimized. To prevent leakage in pressure sections of casings, metal, equal in thickness to at least half the nominal bolt or stud diameter, plus the allowance for corrosion, shall be left around and below the bottom of drilled and threaded holes.

**6.3.19** Internal bolting shall be of a material fully resistant to corrosive attack by the pumped liquid.

**6.3.20** If the manufacture of cast pressure casing parts requires the use of openings for core support, core removal, or waterway inspection and cleaning, these openings shall be designed so they can be closed by welding, using an appropriate, qualified weld procedure, during the completion of casting manufacture.

- **6.3.21** If specified, the main casing joint studs and nuts shall be designed for the use of hydraulic bolt tensioning. Procedures and extent of special tooling provided by the vendor shall be agreed.

NOTE Hydraulic bolt tensioning of casing bolt studs and nuts is generally applicable to specific pump types such as BB3 and BB5.

## **6.4 Nozzles and Pressure Casing Connections**

### **6.4.1 Casing Opening Sizes**

**6.4.1.1** Openings for nozzles and other pressure casing connections shall be standard pipe sizes. Openings of nominal pipe size (NPS)  $1\frac{1}{4}$ , NPS  $2\frac{1}{2}$ , NPS  $3\frac{1}{2}$ , NPS 5, NPS 7, and NPS 9 [diameter nominal (DN) 32, DN 65, DN 90, DN 125, DN 175, and DN 225] shall not be used.

**6.4.1.2** Casing connections other than suction and discharge nozzles shall be at least NPS  $\frac{1}{2}$  (DN 15) for pumps with discharge nozzle openings NPS 2 (DN 50) and smaller. Connections shall be at least NPS  $\frac{3}{4}$  (DN 20) for pumps with discharge nozzle openings NPS 3 (DN 80) and larger, except that connections for seal flush piping and gauges may be NPS  $\frac{1}{2}$  (DN 15) regardless of pump size.

## 6.4.2 Casing Nozzle Connections

**6.4.2.1** All casing connection nozzles shall be flanged, except for the seal gland connection, or those on pumps with forged casings, which shall be flanged or machined and studded. One- and two-stage pumps shall have suction and discharge flanges of equal rating. If the pump is supplied with machined and studded connections, the pump vendor shall provide drawings showing the dimensions of break-out spool pieces to allow the pump to be conveniently removed from the piping. Spool pieces shall be provided by the purchaser.

NOTE Break-out spool pieces eliminate the requirement to remove large sections of piping in order to take the pump casing out during major overhauls.

**6.4.2.2** All nozzle flanges shall conform to the pressure ratings and dimensional requirements of ASME B16.5 and ASME B16.47 Series B, except as noted in 6.4.2.2.1, 6.4.2.2.2, 6.4.2.3, and 6.4.2.4.

NOTE For the purpose of this standard, ISO 7005-1 and EN 1759.1 are equivalent to ASME B16.5 and ASME B16.47.

**6.4.2.2.1** For ASME B16.5 flange sizes from 1/2 NPS (12 mm) to 10 NPS (250 mm), the actual outside diameters (ODs) of the flanges shall be not less than their nominal OD minus 0.16 in. (4 mm). For ASME B16.5 flange sizes from 12 NPS (300 mm) to 24 NPS (600 mm), the actual ODs of the flanges shall be not less than their nominal OD minus 0.21 in. (5 mm).

NOTE These tolerances are consistent with the negative tolerances stated on EN 1092-1, Table 22.

**6.4.2.2.2** For ASME B16.47 flanges, the actual ODs of the flanges shall be not less than their nominal OD minus 0.25 in. (6 mm).

**6.4.2.3** Flanges in all materials that are thicker or have a larger OD than required by the relevant ISO or ASME standards in this standard are acceptable. Nonstandard (oversized) flanges shall be completely dimensioned on the arrangement drawing. If nonstandard flanges require studs or bolts of nonstandard length, this requirement shall be identified on the arrangement drawing.

**6.4.2.4** Flanges shall be full faced or spot faced on the back and shall be designed for through bolting, except for jacketed casings. If nonstandard stud lengths are required for extra-thick flanges, the vendor shall provide studs of the appropriate length.

**6.4.2.5** To minimize nozzle loading and facilitate installation of piping, machined faces of pump flanges shall be parallel to the plane of the flange as shown on the general arrangement drawing within 0.5°. Bolt holes or studs shall straddle centerlines parallel to the main axes of the pump.

**6.4.2.6** Connections, including gusseting, welded to the casing (up to the first flange) shall meet or exceed the material and the pressure-temperature requirements of the casing, including impact values, rather than the requirements of the connected piping. For C6 construction, 316L piping and fittings are required for process temperatures up to and including 500 °F (260 °C), above which UNS N06625 materials shall be used. Gussets shall be a minimum of 316L in either case.

**6.4.2.7** All connection welding shall be completed before the casing is hydrostatically tested (see 8.3.2).

**6.4.2.8** All connections shall be suitable for the hydrostatic test pressure of the region of the casing to which they are attached.

**6.4.2.9** All of the purchaser's connections shall be accessible for disassembly without requiring the pump, or any major part of the pump, to be moved.

## 6.4.3 Auxiliary Connections

**6.4.3.1** Auxiliary connections shall be integrally flanged, socket welded, or butt welded as specified by the purchaser. Seal welding of threaded connections is not permitted.

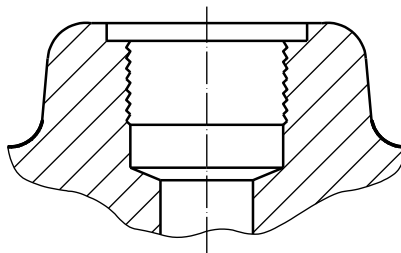


- **6.4.3.2** If specified, for pumps in pipeline service with a maximum operating temperature of 130 °F (55 °C) or less, auxiliary connections may be threaded. Threaded openings shall be tapered threads in accordance with ASME B1.20.1 or ISO 7-1 or alternatively cylindrical threads in accordance with ISO 228-1. Cylindrical threads shall be sealed with a contained face gasket of suitable material sealing to a machined face (see Figure 19). The chosen method and details of threaded connection shall be approved by the purchaser. Where possible, threaded connections shall be brought to a remote flange that can be disassembled for maintenance so as to require the least amount of assembly/disassembly of the threaded connection.

NOTE 1 Threaded connections on pressure-containing parts are prone to leakage.

NOTE 2 Tapered threads create a seal by deformation of threads or use of a suitable thread sealant. They are prone to leakage if under-torqued and prone to thread damage if overtorqued.

NOTE 3 Cylindrical threads with a face gasket require suitable gasket material and are prone to leakage due to under-torque (inadequate gasket compression) or overtorque (extruding of the gasket). Surface finish and condition of the gasket mating faces are critical for proper sealing.



**Figure 19—Machined Face Suitable for Gasket Containment if Using Cylindrical Threads**

- **6.4.3.3** If specified, special threaded fittings for transitioning from the casing to tubing for seal flush piping may be used provided that a secondary sealing feature, such as O-rings, are used and that the joint does not depend on the thread contact alone to seal the fluid. The connection boss shall have a machined face suitable for sealing contact.
- 6.4.3.4** The first segment of piping connected to the casing shall not be more than 6 in. (150 mm) long and shall be a minimum of schedule 160 seamless for pipe sizes NPS 1 (DN 25) and smaller and a minimum of schedule 80 for pipe sizes NPS 1 1/2 (DN 40) and larger. The first segment of piping (nipple) shall be straight, if practical, to allow connections such as drains to be cleaned. The first segment can attach axially to avoid increasing centerline height (see 7.4.5). On small pumps, if this causes interference with the suction nozzle, for example, this requirement is considered impractical.
- 6.4.3.5** Threaded openings, which are allowed in seal glands and in pump casings for some pipeline services (if specified in 6.4.3.2), shall be plugged. Plugs for tapered threads shall be long-shank solid round-head, or long-shank hexagon-head, bar stock plugs in accordance with ASME B16.11. Plugs for cylindrical threads shall be solid hexagon-head plugs in accordance with DIN 910. These plugs shall meet the material requirements of the casing. A lubricant/sealant that is suitable for high-temperature duty shall be used to ensure that the threads are vapor-tight. Plastic plugs are not permitted.
- **6.4.3.6** If specified, auxiliary connections to the pressure casing shall be machined and studded. These connections shall conform to the facing and drilling requirements of 6.4.2.2. Studs and nuts shall be furnished installed. If the stud engagement does not control the depth of the threads in the mating hole, the first 1.5 threads at both ends of the stud shall be removed.
- 6.4.3.7** All pumps shall be provided with vent and drain connections, except that vent connections may be omitted if the pump is made self-venting by the arrangement of the nozzles. Pumps that are not self-venting shall be provided with vent connections in the pressure casing, as required (see 6.8.10). If the pump cannot be completely drained for geometrical reasons, this shall be stated in the proposal. The operating manual shall include a drawing indicating the quantity and location(s) of the liquid remaining in the pump.

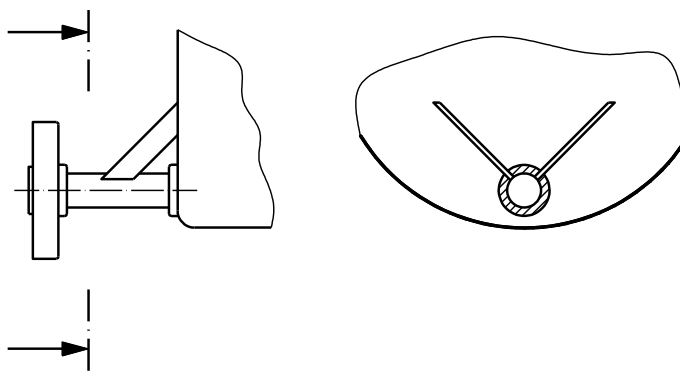
**NOTE** As a guide, a pump is considered functionally self-venting if the nozzle arrangement and the casing configuration permit sufficient venting of gases from the first-stage impeller and volute area to prevent loss of prime during the starting sequence.

**6.4.3.8** A process compatible thread lubricant of proper temperature specification shall be used on all threaded connections. Thread tape shall not be used.

**6.4.3.9** For socket-welded construction, there shall be a  $1/16$  in. (1.5 mm) gap between the pipe end and bottom of the socket before welding.

**6.4.3.10** Piping NPS 1 and smaller shall be gusseted in two orthogonal planes to increase the rigidity of the piped connection, in accordance with the following stipulations, except connections for seal flush piping and gauges.

- a) Gussets shall be of a material compatible with the pressure casing and the piping and shall be made of either flat bar with a minimum cross section of 1 in. by 0.12 in. (25 mm by 3 mm) or round bar with a minimum diameter of 0.38 in. (9 mm).
- b) Gusset design shall be typically as shown in Figure 20.



**Figure 20—Typical Gusset Design**

- c) Gussets shall be located at or near the connection end of the piping and fitted to the closest convenient location on the casing to provide maximum rigidity. The long width of gussets made with bar shall be perpendicular to the pipe and shall be located to avoid interference with the flange bolting or any maintenance areas on the pump.
- d) Gusset welding shall meet the fabrication requirements (see 6.12.3), including postweld heat treatment (PWHT) when required, and the inspection requirements (see 8.2.2) of this standard.
- e) Gussets may also be bolted to the casing if drilling and tapping is done prior to hydrostatic test. Proposals to use clamped or bolted gusset designs shall be submitted to the purchaser for approval.

## 6.5 External Nozzle Forces and Moments

**6.5.1** Steel and alloy-steel horizontal pumps and their baseplates, vertical in-line pumps with supports anchored to the foundation, and vertically suspended pumps shall be designed for satisfactory performance if subjected to the forces and moments in Table 5 applied simultaneously to both suction and discharge nozzles in the worst-case combination for the pump in question. For horizontal pumps, two effects of nozzle loads are considered: distortion of the pump casing (see 6.3.3 and 6.3.4) and misalignment of the pump and driver shafts (see 7.4.23).

**6.5.2** Allowable forces and moments for vertical in-line pumps with supports not anchored to the foundation may be twice the values in Table 5 for side nozzles.

**6.5.3** For pump casings constructed of materials other than steel or alloy steel or for pumps with nozzles larger than NPS 16 (DN 400), the vendor shall submit allowable nozzle loads corresponding to the format in Table 5.

**6.5.4** The coordinate system(s) shown in Figure 21, Figure 22, Figure 23, Figure 24, and Figure 25 shall be used to apply the forces and moments in Table 5.

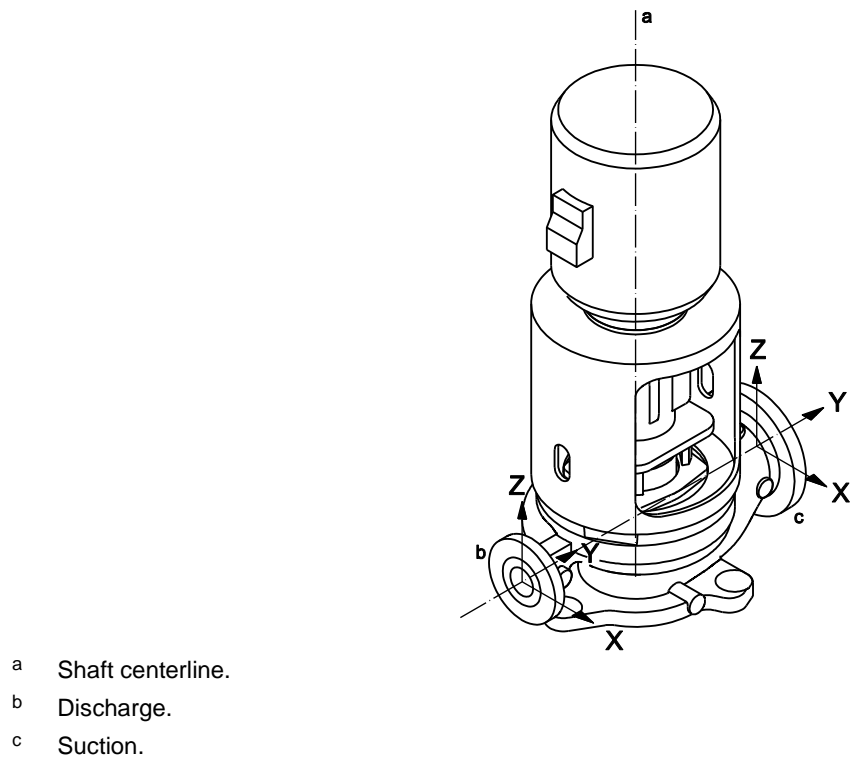
- **6.5.5** Annex F gives methods of qualifying nozzle loads in excess of those in Table 5. The purchaser should be aware that the use of the methods in Annex F can result in a misalignment up to 50 % greater than that based on the loads given in Table 5 and can impact equipment installation criteria. The use of the methods in Annex F requires approval by the purchaser and specific direction to the piping designers with regard to how to apply the equations in the Annex to the system design.

**Table 5—Nozzle Loadings**

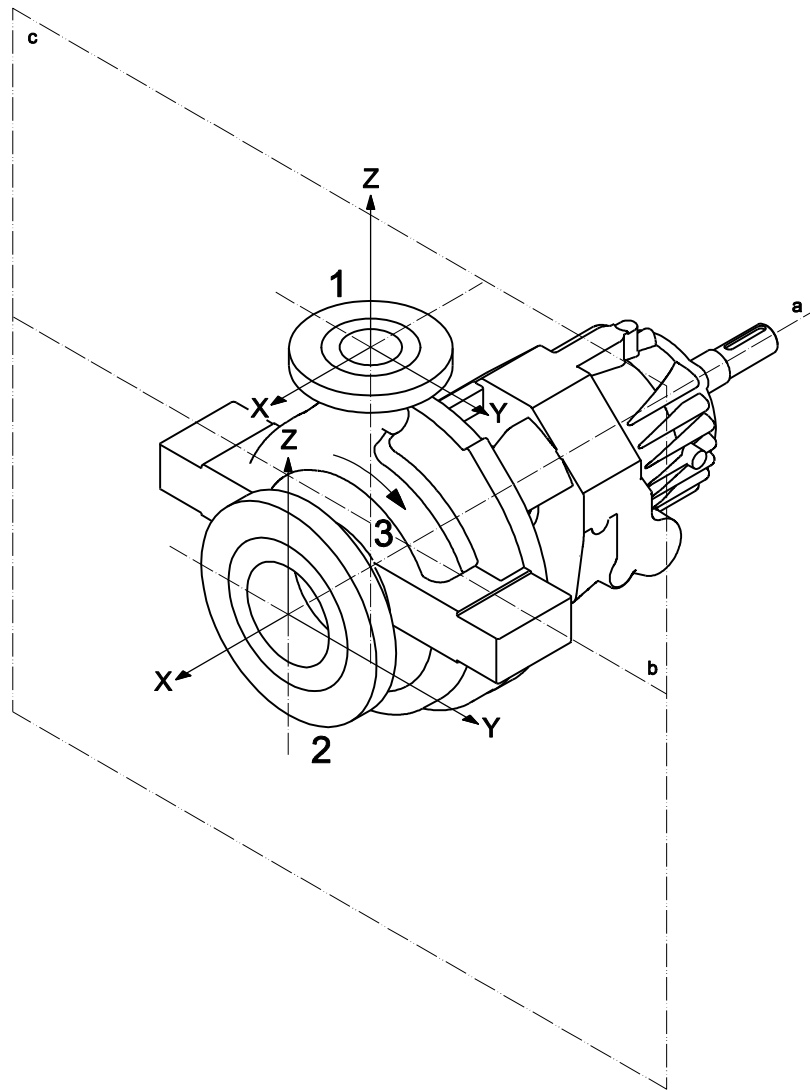
Location/Orientation	Nozzle-loading Force as a Function of Flange Size—USC Units lbf								
	Nominal Size of Flange (NPS)								
	≤ 2	3	4	6	8	10	12	14	16
Each top nozzle									
$F_X$	160	240	320	560	850	1200	1500	1600	1900
$F_Y$	130	200	260	460	700	1000	1200	1300	1500
$F_Z$	200	300	400	700	1100	1500	1800	2000	2300
$F_R$	290	430	570	1010	1560	2200	2600	2900	3300
Each side nozzle									
$F_X$	160	240	320	560	850	1200	1500	1600	1900
$F_Y$	200	300	400	700	1100	1500	1800	2000	2300
$F_Z$	130	200	260	460	700	1000	1200	1300	1500
$F_R$	290	430	570	1010	1560	2200	2600	2900	3300
Each end nozzle									
$F_X$	200	300	400	700	1100	1500	1800	2000	2300
$F_Y$	160	240	320	560	850	1200	1500	1600	1900
$F_Z$	130	200	260	460	700	1000	1200	1300	1500
$F_R$	290	430	570	1010	1560	2200	2600	2900	3300
<b>Moment</b> ft·lbf									
Each nozzle									
$M_X$	340	700	980	1700	2600	3700	4500	4700	5400
$M_Y$	170	350	500	870	1300	1800	2200	2300	2700
$M_Z$	260	530	740	1300	1900	2800	3400	3500	4000
$M_R$	460	950	1330	2310	3500	5000	6100	6300	7200
NOTE 1 See Figure 21 through Figure 25 for orientation of nozzle loads (X, Y, and Z).									
NOTE 2 Each value shown above indicates range from minus that value to plus that value; e.g. 160 indicates a range from -160 to +160.									

Table 5—Nozzle Loadings (Continued)

Location/Orientation	Nozzle-loading Force as a Function of Flange Size—SI Units								
	N								
	Nominal Size of Flange (DN)								
	≤ 50	80	100	150	200	250	300	350	400
Each top nozzle									
$F_X$	710	1070	1420	2490	3780	5340	6670	7120	8450
$F_Y$	580	890	1160	2050	3110	4450	5340	5780	6670
$F_Z$	890	1330	1780	3110	4890	6670	8000	8900	10,230
$F_R$	1280	1930	2560	4480	6920	9630	11,700	12,780	14,850
Each side nozzle									
$F_X$	710	1070	1420	2490	3780	5340	6670	7120	8450
$F_Y$	890	1330	1780	3110	4890	6670	8000	8900	10,230
$F_Z$	580	890	1160	2050	3110	4450	5340	5780	6670
$F_R$	1280	1930	2560	4480	6920	9630	11,700	12,780	14,850
Each end nozzle									
$F_X$	890	1330	1780	3110	4890	6670	8000	8900	10,230
$F_Y$	710	1070	1420	2490	3780	5340	6670	7120	8450
$F_Z$	580	890	1160	2050	3110	4450	5340	5780	6670
$F_R$	1280	1930	2560	4480	6920	9630	11,700	12,780	14,850
<b>Moment</b>									
N·m									
Each nozzle									
$M_X$	460	950	1330	2300	3530	5020	6100	6370	7320
$M_Y$	230	470	680	1180	1760	2440	2980	3120	3660
$M_Z$	350	720	1000	1760	2580	3800	4610	4750	5420
$M_R$	620	1280	1800	3130	4710	6750	8210	8540	9820

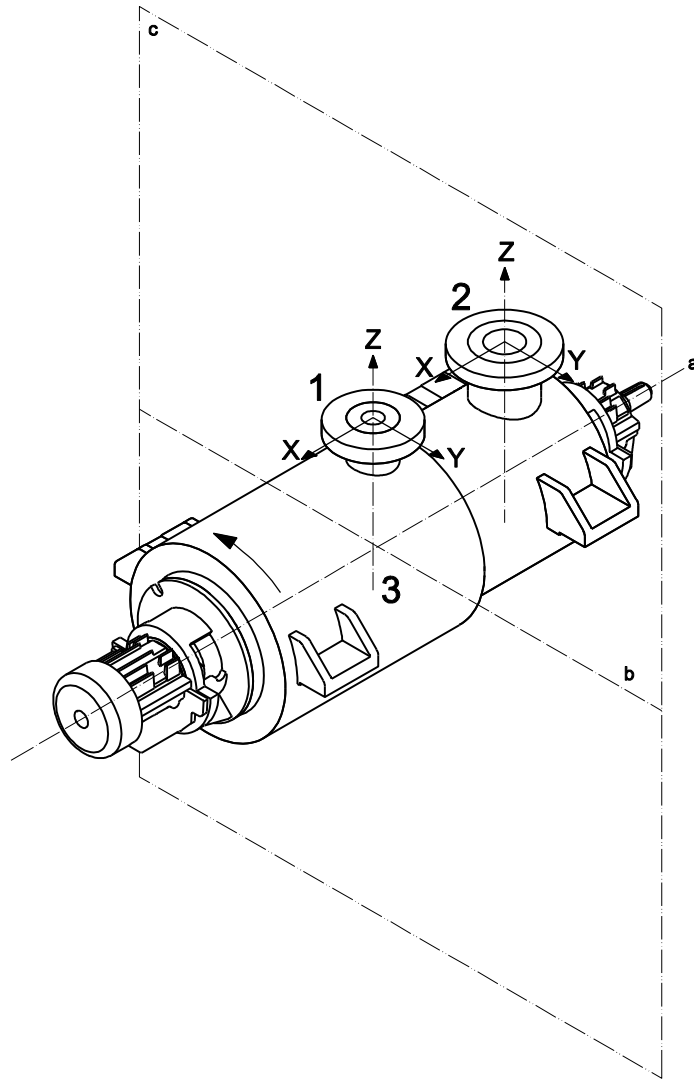


**Figure 21—Coordinate System for the Forces and Moments in Table 5, Vertical In-line Pumps**

**Key**

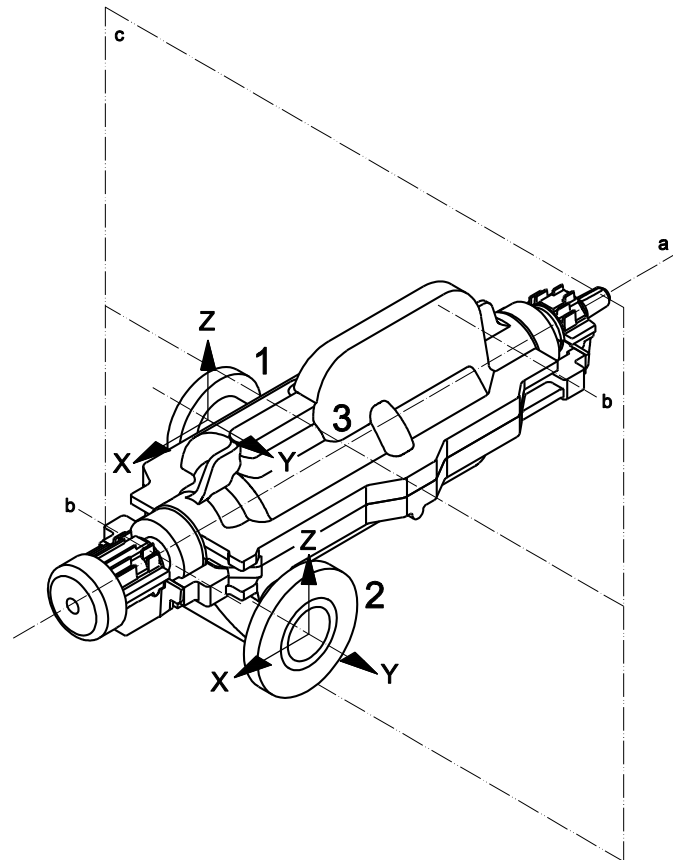
- 1 discharge nozzle
- 2 suction nozzle
- 3 center of pump
- a Shaft centerline.
- b Pedestal centerline.
- c Vertical plane.

**Figure 22—Coordinate System for the Forces and Moments in Table 5, Horizontal Pumps with End Suction and Top Discharge Nozzles**

**Key**

- 1 discharge nozzle
- 2 suction nozzle
- 3 center of pump
- a Shaft centerline.
- b Pedestal centerline.
- c Vertical plane.

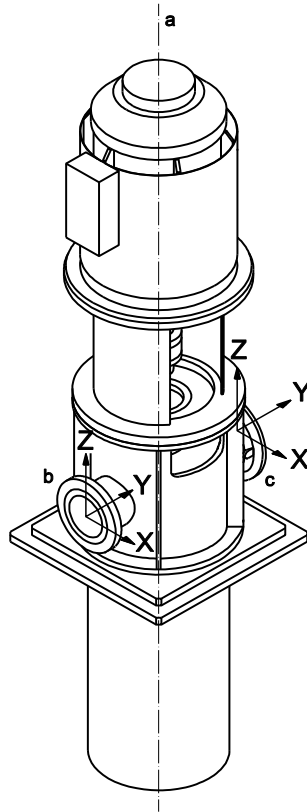
**Figure 23—Coordinate System for the Forces and Moments in Table 5, Horizontal Pumps with Top Nozzles**

**Key**

- 1 discharge nozzle
- 2 suction nozzle
- 3 center of pump
- a Shaft centerline.
- b Pedestal centerline.
- c Vertical plane.

**Figure 24—Coordinate System for the Forces and Moments in Table 5, Horizontal Pumps with Side Suction and Side Discharge Nozzles**





- a Shaft centerline.
- b Discharge.
- c Suction.

**Figure 25—Coordinate System for the Forces and Moments in Table 5, Vertically Suspended, Double-casing Pumps**

## 6.6 Rotors

### 6.6.1 Impellers shall be of the fully enclosed, semi-open or open type.

**NOTE** Enclosed (closed) impellers are less sensitive to axial position and, therefore, preferable for long shaft assemblies where axial displacement due to thermal expansion/contraction or to thrust can be substantial. Semi-open impellers can offer a higher efficiency, due to the elimination of disc friction from one shroud. The running clearances for semi-open impellers in vertical pumps can be adjusted from the coupling or top of the motor, thus possibly restoring efficiency and pump output without disassembly of pump parts. The open impeller is typically of an axial-flow propeller type designed for large capacities at low heads; the open impeller is also used for volute sump pumps with a separate discharge.

### 6.6.2 Impellers shall be single-piece castings, forgings, or fabrications.

**NOTE** Impellers made as forgings or fabrications have machined waterways, which can offer improved performance for low-specific-speed designs.

**6.6.3** Impellers shall be keyed to the shaft. Pinning of impellers to the shaft is not acceptable. With the purchaser's approval, collets may be used in vertically suspended pumps. Overhung impellers shall be secured to the shaft by a cap screw or cap nut that does not expose shaft threads. The securing device shall be threaded to tighten by liquid drag on the impeller during normal rotation, and a positive mechanical locking method (e.g. a staked and corrosion-resistant set-screw or a tongue-type washer) is required. Cap screws shall have fillets and a reduced-diameter shank to reduce stress concentrations.

### 6.6.4 All shaft keyways shall have fillet radii in accordance with ASME B17.1 or ISO 3117.

**6.6.5** Impellers shall have solid hubs. Impellers may have cored hubs if the core is completely filled with a suitable metal that has a melting point of not less than 1000 °F (540 °C).

NOTE The requirement to fill cored impeller hubs is intended to minimize the danger to personnel if and when impellers are removed by heating.

**6.6.6** For shafts that require sleeve gaskets to pass over threads, at least 0.06 in. (1.5 mm) radial clearance shall be provided between the threads and the internal diameter of the gasket, and the diameter transition shall be chamfered in accordance with 6.3.15.

**6.6.7** The shaft-to-seal sleeve fit(s) shall be F7/h6 in accordance with ISO 286 (all parts).

**6.6.8** Areas of shafts that can be damaged by set-screws shall be relieved to facilitate the removal of sleeves or other components.

**6.6.9** Shafts shall be single-piece construction, machined, and finished throughout their length so that the total indicated runout (TIR) is not more than 0.001 in. (25 µm). Shafts constructed of multiple pieces assembled together, such as stub shaft extensions to drive lube oil pumps, shall require purchaser's approval.

**6.6.10** If noncontacting shaft vibration probes are furnished in accordance with 7.5.2.2, the shaft sensing areas (both radial vibration and axial position) for observation by radial vibration probes shall:

- a) be concentric with the bearing journals;
- b) be free from stencil and scribe marks or any other surface discontinuity, such as an oil hole or a keyway, for a minimum distance of one probe tip diameter on each side of the probe;
- c) not be metallized, sleeved, or plated on rotors made of materials that exhibit consistent electrical properties;
- d) have a final surface finish of 32 µin. (0.8 µm) Ra or smoother, preferably obtained by honing or burnishing;
- e) be properly demagnetized to the levels specified in API 670, or otherwise treated so that the combined total electrical and mechanical runout does not exceed the following:
  - 1) for areas observed by radial vibration probes, 25 % of the allowed peak-to-peak vibration amplitude or 0.25 mil (6 µm), whichever is greater;
  - 2) for areas to be observed by axial position probes, 0.5 mil (13 µm).

**6.6.11** If the shaft is made of material that exhibits inconsistent electrical properties, the shaft-sensing areas may be produced by shrink-fitting sleeves or target rings on the shaft. Target rings shall be finished in accordance with 6.6.10 and shall be identified in the technical documentation. Materials known to exhibit inconsistent electrical properties are high-chromium alloys such as 17-4 PH, duplex stainless steel, and many austenitic stainless steels.

**6.6.12** If provisions for mounting noncontacting shaft vibration probes are specified (7.5.2.2), the shaft shall be prepared in accordance with the requirements of 6.6.10 and API 670.

**6.6.13** If noncontacting shaft vibration probes are furnished, accurate records of electrical and mechanical runout for the full 360° at each probe location shall be included in the mechanical test report. Electrical and mechanical runout records shall be phase referenced to a permanent location on the shaft such as a key slot.

## **6.7 Wear Rings and Running Clearances**

**6.7.1** Radial running clearances shall be used to limit internal leakage and, where necessary, balance axial thrust. Impeller pump-out vanes or close axial clearances shall not be used to balance axial thrust. Renewable

wear rings shall be provided in the pump casing. Impellers shall have either integral wear surfaces or renewable wear rings.

**6.7.2** Mating wear surfaces of hardenable materials shall have a difference in Brinell hardness number of at least 50 unless both the stationary and the rotating wear surfaces have Brinell hardness numbers of at least 400.

**6.7.3** Renewable metallic wear rings, if used, shall be held in place by a press fit with locking pins, screws (axial or radial), or by tack welding. The diameter of a hole in a wear ring for a radial pin or threaded dowel shall not be more than one-third the width of the wear ring.

**6.7.4** Nonmetallic wear rings may be installed in holders or directly into the casing. If suitable data exists showing that a press fit is sufficient for prevention of rotation and with purchaser approval, other mechanical anti-rotation features are not required.

**6.7.5** Running clearances shall meet the following requirements.

- a) When establishing internal running clearances between wear rings and other moving parts, consideration shall be given to pumping temperatures, suction conditions, the liquid properties, the thermal expansion and galling characteristics of the materials, and pump efficiency. Clearances shall be sufficient to assure dependability of operation and freedom from seizure under all specified operating conditions.
- b) For cast iron, hardened martensitic stainless steel, and other materials with similarly low galling tendencies, the minimum diametral clearances given in Table 6 shall be used, unless otherwise approved by the purchaser. For materials with higher galling tendencies or for all materials operating at temperatures above 500 °F (260 °C), 0.005 in. (125 µm) shall be added to these diametral clearances.

NOTE If materials with higher galling tendencies are operated at temperatures above 500 °F (260 °C), adding 0.005 in. (125 µm) to the diametral clearances in Table 6 is typically done only once.

- c) For nonmetallic wear-ring materials with very low or no galling tendencies (see Table H.3), as well as other wear-ring material combinations with proven operating experience, clearances less than those given in Table 6 may be proposed by the manufacturer to improve pump efficiency. Factors such as distortion and thermal gradients shall be considered to ensure clearances are sufficient to provide dependability of operation and freedom from seizure under all specified operating conditions.

NOTE There are published data showing successful applications of nonmetallic wear-ring materials with API clearances [see 6.7.5 b)] reduced by 50 %. Reasonable reductions in clearances are believed to be dependent on the materials applied and other service conditions, such as cleanliness and temperature.

**Table 6—Minimum Internal Running Clearances**

Diameter of Rotating Member at Clearance in.	Minimum Diametral Clearance in.	Diameter of Rotating Member at Clearance mm	Minimum Diametral Clearance mm
< 2.000	0.010	< 50	0.25
2.000 to 2.499	0.011	50 to 64.99	0.28
2.500 to 2.999	0.012	65 to 79.99	0.30
3.000 to 3.499	0.013	80 to 89.99	0.33
3.500 to 3.999	0.014	90 to 99.99	0.35
4.000 to 4.499	0.015	100 to 114.99	0.38
4.500 to 4.999	0.016	115 to 124.99	0.40
5.000 to 5.999	0.017	125 to 149.99	0.43
6.000 to 6.999	0.018	150 to 174.99	0.45
7.000 to 7.999	0.019	175 to 199.99	0.48
8.000 to 8.999	0.020	200 to 224.99	0.50
9.000 to 9.999	0.021	225 to 249.99	0.53
10.000 to 10.999	0.022	250 to 274.99	0.55
11.000 to 11.999	0.023	275 to 299.99	0.58
12.000 to 12.999	0.024	300 to 324.99	0.60
13.000 to 13.999	0.025	325 to 349.99	0.63
14.000 to 14.999	0.026	350 to 374.99	0.65
15.000 to 15.999	0.027	375 to 399.99	0.68
16.000 to 16.999	0.028	400 to 424.99	0.70
17.000 to 17.999	0.029	425 to 449.99	0.73
18.000 to 18.999	0.030	450 to 474.99	0.75
19.000 to 19.999	0.031	475 to 499.99	0.78
20.000 to 20.999	0.032	500 to 524.99	0.80
21.000 to 21.999	0.033	525 to 549.99	0.83
22.000 to 22.999	0.034	550 to 574.99	0.85
23.000 to 23.999	0.035	575 to 599.99	0.88
24.000 to 24.999	0.036	600 to 624.99	0.90
25.000 to 25.999	0.037	625 to 649.99 <sup>a</sup>	0.95

<sup>a</sup> For diameters greater than 25.999 in. (649.99 mm), the minimum diametral clearances shall be 0.037 in. (0.95 mm) plus 0.001 in. for each additional 1.0 in. of diameter or fraction thereof (1 µm for each additional 1.0 mm of diameter).

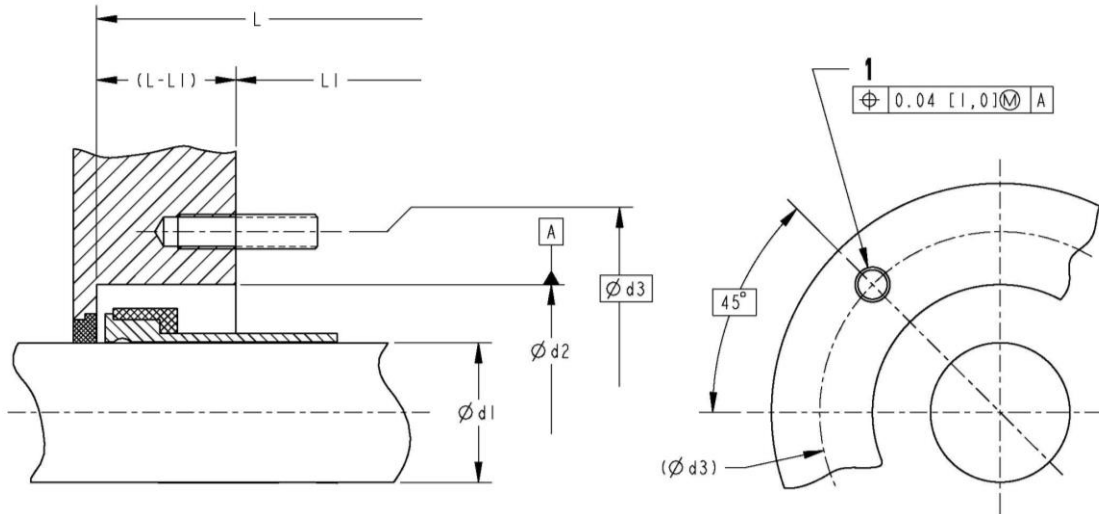
## 6.8 Mechanical Shaft Seals

- **6.8.1** Pumps shall be equipped with mechanical seals and sealing systems in accordance with API 682. Pump and seal interface dimensions shall be in accordance with Table 7 and Figure 26 of this standard. The purchaser shall specify the category of seal required.

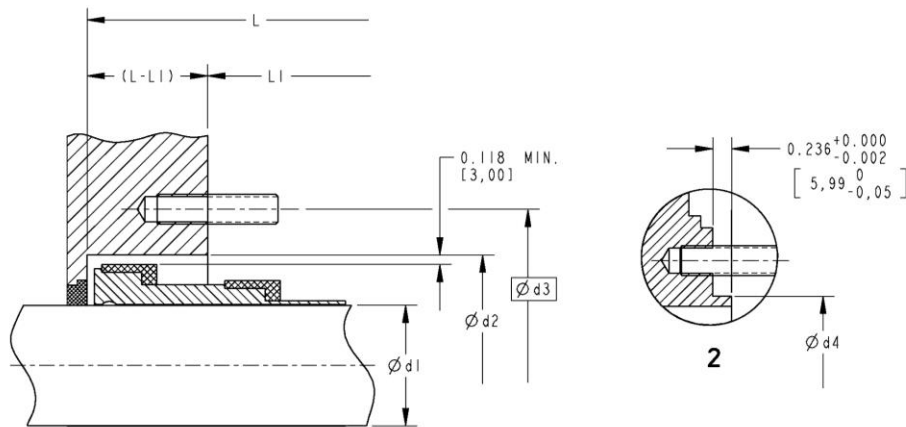
**6.8.2** The seal cartridge shall be removable without disturbing the driver.

**6.8.3** The seal chamber shall conform to the dimensions shown in Figure 26 and Table 7. For pumps with flange and pump pressure ratings in excess of the minimum values in 6.3.6, the gland stud size and bolt circle diameter may be increased. Larger studs shall only be used to meet the stress requirements of 6.3.4 or to sufficiently compress spiral-wound gaskets in accordance with manufacturer's specifications.

Dimensions in inches (millimeters)



a) Single Seal



b) Dual Seal

**Key**

- 1 gland studs (four)
- 2 optional outside gland rabbet
- $l$  total length to nearest obstruction
- $l_1$  length from seal chamber face to nearest obstruction

**Figure 26—Chamber Diagrams**

**Table 7—Standard Dimensions for Seal Chambers, Seal Gland Mounting, and Cartridge Mechanical Seal Sleeves**

Dimensions in inches (millimeters)

Seal Chamber Size	Shaft Diameter Max. <sup>a</sup>	Seal Chamber Bore <sup>b</sup>	Gland Bolt Circle Diameter	Outside Gland Rabbet <sup>c</sup>	Total Length Min. <sup>d</sup>	Clear Length Min. <sup>d</sup>	Stud Size	
	$d_1$	$d_2$	$d_3$	$d_4$	$l$	$l_1$	USC	SI
1	0.787 (20.00)	2.756 (70.00)	4.13 (105)	3.346 (85.00)	5.90 (150)	3.94 (100)	1/2"-13	M12 × 1.75
2	1.181 (30.00)	3.150 (80.00)	4.53 (115)	3.740 (95.00)	6.10 (155)	3.94 (100)	1/2"-13	M12 × 1.75
3	1.575 (40.00)	3.543 (90.00)	4.92 (125)	4.134 (105.00)	6.30 (160)	3.94 (100)	1/2"-13	M12 × 1.75
4	1.968 (50.00)	3.937 (100.00)	5.51 (140)	4.528 (115.00)	6.50 (165)	4.33 (110)	5/8"-11	M16 × 2.0
5	2.362 (60.00)	4.724 (120.00)	6.30 (160)	5.315 (135.00)	6.69 (170)	4.33 (110)	5/8"-11	M16 × 2.0
6	2.756 (70.00)	5.118 (130.00)	6.69 (170)	5.709 (145.00)	6.89 (175)	4.33 (110)	5/8"-11	M16 × 2.0
7	3.150 (80.00)	5.512 (140.00)	7.09 (180)	6.102 (155.00)	7.09 (180)	4.33 (110)	5/8"-11	M16 × 2.0
8	3.543 (90.00)	6.299 (160.00)	8.07 (205)	6.890 (175.00)	7.28 (185)	4.72 (120)	3/4"-10	M20 × 2.5
9	3.937 (100.00)	6.693 (170.00)	8.46 (215)	7.283 (185.00)	7.48 (190)	4.72 (120)	3/4"-10	M20 × 2.5
10	4.331 (110.00)	7.087 (180.00)	8.86 (225)	7.677 (195.00)	7.68 (195)	4.72 (120)	3/4"-10	M20 × 2.5

<sup>a</sup> Dimensions to tolerance Class h6.

<sup>b</sup> Dimensions to tolerance Class H7; for axially split pumps, an additional tolerance of ±0.003 in. (75 μm) to allow for gasket thickness.

<sup>c</sup> Dimensions to tolerance Class f7.

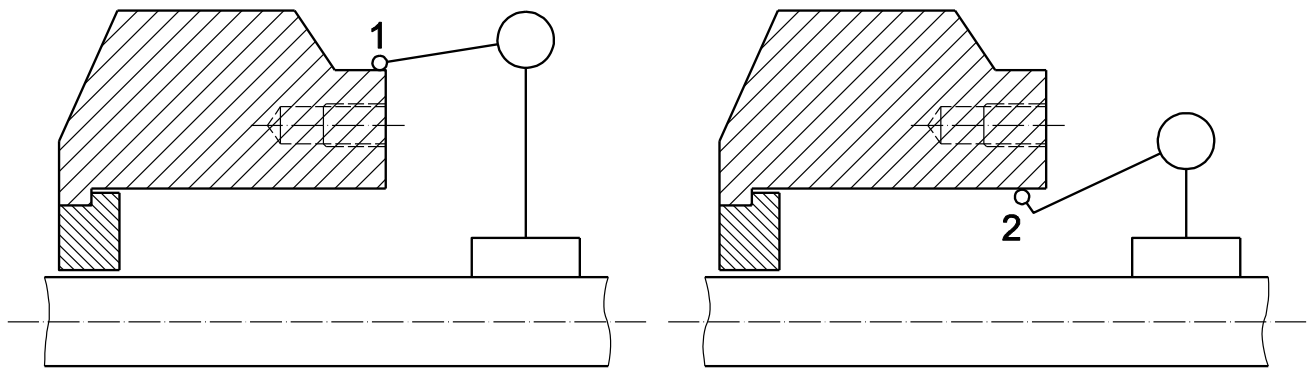
<sup>d</sup> Shaft deflection criteria (6.9.1.3) may require the reduction of dimensions  $l$  and  $l_1$  on size 1 and size 2 seal chambers to below the minimum values listed, depending on specific pump construction and casing design. Size 1 and size 2 seal chambers are not usually found on Type OH2 and OH3 pumps.

**6.8.4** Provisions shall be made to center the seal gland and/or chamber with either an inside or OD register fit. The register fit surface shall be concentric to the shaft and shall have a TIR of not more than 0.005 in. (125 μm). Using the seal-gland bolts to center mechanical seal components is not acceptable (see Figure 27). To account for bearing internal clearances, TIR measurements are to be taken with the assembly in the vertical position for overhung pumps.

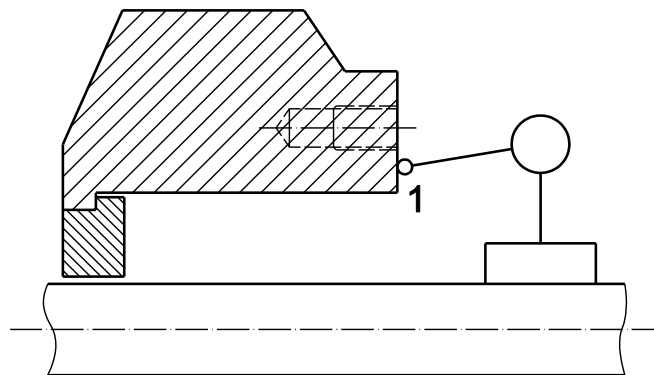
**6.8.5** Seal chamber face runout (TIR), in relation to shaft centerline, shall not exceed 0.0005 in./in. (0.5 μm/mm) of seal chamber bore (see Figure 28).

**6.8.6** The mating joint between the seal gland and the seal chamber face shall incorporate a confined gasket to prevent blowout. The gasket shall be of the controlled-compression type, e.g. an O-ring or a spiral-wound gasket with a metal-to-metal joint contact. If space or design limitations make this requirement impractical, an alternative seal gland design shall be submitted to the purchaser for approval.

**6.8.7** Specified seal and pump connections shall be identified by symbols in accordance with API 682 that are permanently marked on the components using stamping, casting, electro-chemical etching, etc.

**Key**

- 1 location of outside diameter register fit measurement
- 2 location of inside diameter register fit measurement

**Figure 27—Seal Chamber Concentricity****Key**

- 1 location of face runout measurement

**Figure 28—Seal Chamber Face Runout**

**6.8.8** Seal glands and seal chambers shall only have those connections that are required by the seal flush plan. Any additional unused connections shall be plugged in accordance with 6.4.3.7.

- **6.8.9** If specified, seal chambers shall be provided with an additional flush port at approximately the center of the chamber and extending vertically upward. This additional flushing port shall be designed in accordance with casing auxiliary connection requirements (see 6.4.3).

**6.8.10** Provision shall be made to ensure complete venting of the seal chamber.

- **6.8.11** If specified, jackets shall be provided on seal chambers for heating. Heating requirements shall be agreed upon by the purchaser, vendor, and seal manufacturer for high-melting-point products.

**6.8.12** Mechanical seals and glands for all pumps, except vertically suspended pumps shipped without mounted drivers, shall be installed in the pump before shipment and shall be clean and ready for initial service. If seals require final adjustment or installation in the field, the vendor shall attach a metal tag warning of this requirement.

- **6.8.13** The vendor and purchaser shall agree on the maximum static and dynamic sealing pressures that can be anticipated to occur in the seal chamber and the seal manufacturer shall state these values on the API 682 mechanical seal data sheet (see 3.1.24 and 3.1.26).

## 6.9 Dynamics

### 6.9.1 General

**6.9.1.1** The topics of critical speed and lateral analysis are covered under each specific pump type in Section 9.

**6.9.1.2** The rotor of one- and two-stage pumps shall be designed so its first dry-bending critical speed is at least 20 % above the pump's maximum continuous operating speed.

**6.9.1.3** To obtain satisfactory seal performance, the shaft stiffness shall limit the total deflection, under the most severe dynamic conditions over the allowable operating range of the pump with maximum diameter impeller(s) and the specified speed and liquid, to 0.002 in. (50  $\mu\text{m}$ ) at the primary seal faces. This shaft-deflection limit may be achieved by a combination of shaft diameter, shaft span or overhang, and casing design (including the use of dual volutes or diffusers). For one- and two-stage pumps, no credit shall be taken for the liquid stiffening effects of impeller wear rings. For multistage pumps, the liquid stiffness of wear rings, product-lubricated bearings, and bearing bushings shall be calculated at both one and two times the nominal design clearances.

### 6.9.2 Torsional Analysis

**6.9.2.1** The flow chart in Figure 29 shall be utilized to determine the torsional analysis performed. The analysis shall be for the train as a whole unless the train includes a fluid coupling. In all cases, the vendor having unit responsibility shall be responsible for directing any modifications necessary to meet the requirements of 6.9.2.3 through 6.9.2.9.

NOTE There are three general types of torsional analyses normally performed on pumps:

- a) undamped natural frequency analysis that determines modes of the rotor's torsional natural frequencies and generates a Campbell diagram to determine potential resonance points;
- b) steady-state forced response analysis that determines the rotor's harmonic response to applicable steady-state excitation sources (e.g. dynamic torque functions) and generates dynamic torsional torques and stresses to evaluate mechanical integrity;
- c) transient forced response analysis that determines the rotor's forced response to applicable transient excitation sources (e.g. motor starting and short-circuit events) and generates dynamic torsional torques and stresses to evaluate mechanical integrity.

**6.9.2.2** An undamped natural frequency analysis shall be performed by the manufacturer having unit responsibility if any of the following describe the machinery train:

- a) multiple couplings: trains comprised of three or more coupled machines rated 2000 hp (1500 kW) or higher;
- b) gears: induction motors, or turbines, through gear rated 2000 hp (1500 kW) or higher;
- c) internal combustion engines: trains with engines rated 335 hp (250 kW) or higher;
- d) synchronous motors: trains with synchronous motors rated 670 hp (500 kW) or higher;
- e) ASDs rated 1350 hp (1000 kW) or higher;
- f) vertically suspended pumps: with a drivers rated 1000 hp (750 kW) or larger;
- g) induction motors: trains with induction (asynchronous) motors rated 2000 hp (1500 kW) or higher.

NOTE 1 Experience of some manufacturers is that vertically suspended pumps, particularly those with long shafts and relatively large inertias in the driver rotor, are susceptible to very small torsional excitations.

NOTE 2 Most modern variable frequency drives (VFDs), if performing properly, produce insignificant torsional vibration and shaft stress. VFD malfunctions can produce significant excitation. Certain designs still exist that produce significant torsional pulsations.



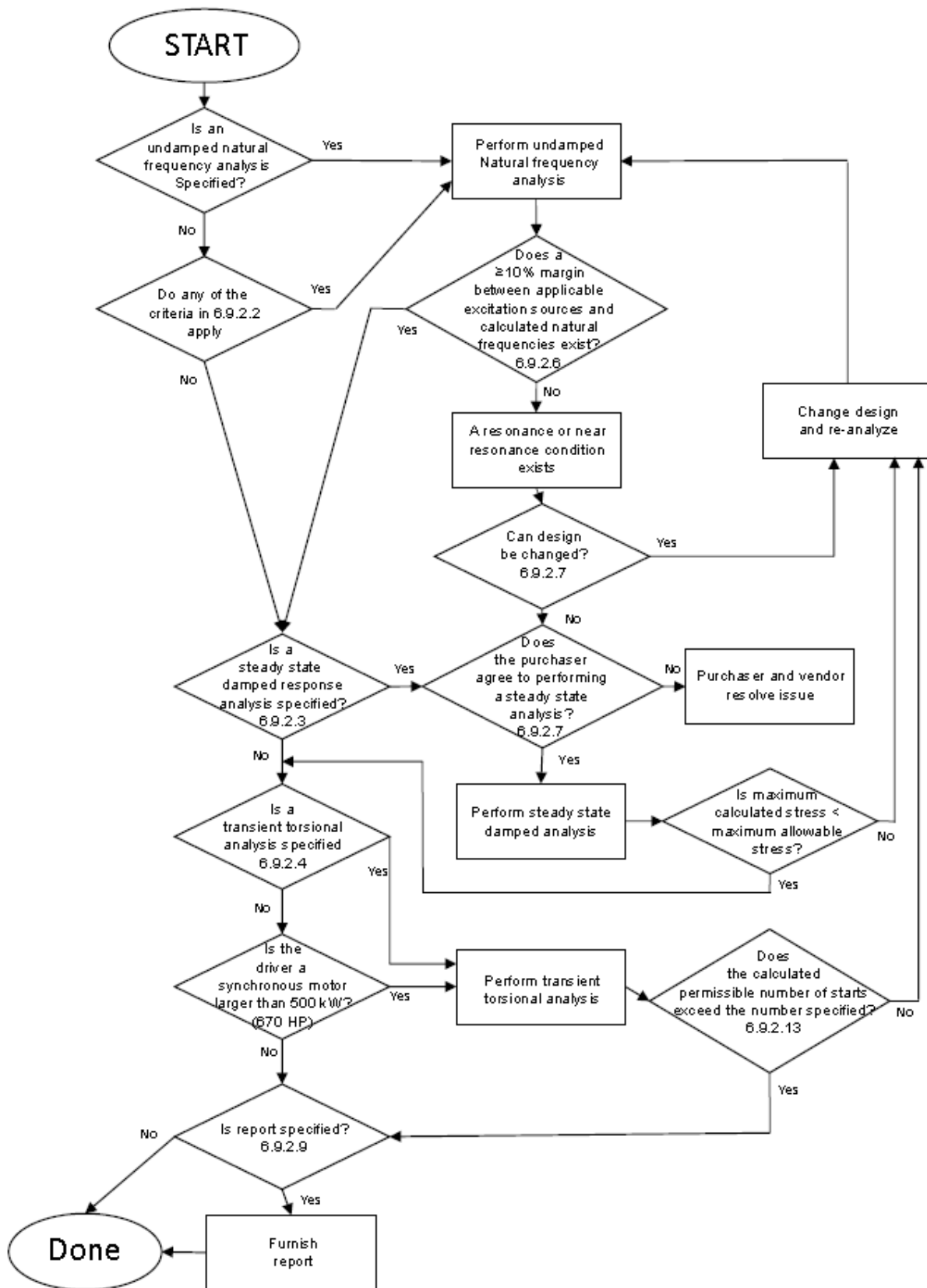


Figure 29—Torsional Analysis Flow Chart

- **6.9.2.3** If specified, for VFDs, a steady-state, forced response analysis shall be performed. The analysis shall consider all resonant frequencies through 12 times line frequency.
- **6.9.2.4** If specified or if the driver is a synchronous motor rated 670 hp (500 kW) or higher, a transient forced response analysis shall be performed. If performed, the time-transient analysis shall meet the requirements of 6.9.2.10 through 6.9.2.13.

NOTE Some purchasers choose to perform forced response transient analyses if generator phase-to-phase or phase-to-ground faults are considered a significant risk or if rapid bus switching occurs on loss of power.

**6.9.2.5** Excitation of torsional natural frequencies can come from many sources, which might or might not be a function of running speed and should be considered in the analysis. These sources can include but are not limited to the following:

- a) pumps and HPRTs: 1 and 2 times rotor speed, impeller vane and cutwater pass frequencies;
- b) gears: mesh frequency;
- c) induction motors: 1 and 2 times the rotor speed and 1 and 2 times line frequency;
- d) 2-cycle engines:  $n$  times the rotor speed where  $n$  is the number of power strokes per revolution;
- e) 4-cycle engines:  $n$  and 0.5 times the rotor speed where  $n$  is the number of power strokes per revolution;
- f) synchronous motors:  $n$  times the slip frequency (transient phenomena only), 1 and 2 times line frequency;
- g) VFDs:  $n$  times the rotor speed, expressed in revolutions per minute, for relevant multiples through 12 times the line frequency, where  $n$  is the number of motor poles.

NOTE In case a torsional analysis of a train with VFDs, VFD torque harmonics are the excitation of concern. These torque functions, dependent on load, are normally requested from the drive manufacturer.

**6.9.2.6** The torsional natural frequencies of the complete train shall be at least 10 % above or 10 % below any applicable excitation frequency, listed in 6.9.2.5, that falls within the specified range of operating speeds (from minimum to maximum continuous speed). If the natural frequency cannot be moved, it shall be shown to have no adverse effect.

**6.9.2.7** If torsional resonances are calculated to fall within the margin specified in 6.9.2.6 (and the purchaser and the vendor have agreed that all efforts to remove the resonance from within the limiting frequency range have been exhausted), a steady-state response analysis shall be performed to demonstrate that the resonances have no adverse effect on the complete train. The assumptions made in this analysis regarding the magnitude of excitation and the degree of damping shall be clearly stated. The acceptance criteria for this analysis shall be agreed upon by the purchaser and the vendor.

NOTE Typically, steady-state forced response torsional analyses of pumps driven by pulse-width-modulated variable-frequency drives have shown acceptably low stresses at the resonant conditions due to VFD excitations; these have no adverse effects on the machinery train.

**6.9.2.8** Unless otherwise specified, if only a steady-state, undamped torsional analysis is performed, a Campbell diagram with a tabulation of the mass elastic data and brief explanation of the calculation method may be furnished to the purchaser in lieu of a report.

- **6.9.2.9** If specified, or if either a steady-state or transient forced response analysis is performed, the manufacturer shall furnish a detailed report of the torsional analysis. The report shall include the following:
  - a) description of the method(s) used to calculate the train torsional natural frequencies;
  - b) diagram of the mass elastic system;

- c) table of the mass moment and torsional stiffness of each element of the mass elastic system;
- d) Campbell diagram;
- e) mode-shape diagram with peak stresses shown for each resonant frequency.

**6.9.2.10** In addition to the parameters used to perform, an undamped torsional natural frequency analysis as specified in 6.9.2.2, the following shall be included in the transient forced response analysis:

- a) motor average torque, as well as pulsating torque (direct and quadrature axis) vs speed characteristics;
- b) load torque vs speed characteristics;
- c) electrical system characteristics affecting the motor terminal voltage or the assumptions made concerning the terminal voltage, including the method of starting, such as across the line, or some method of reduced voltage starting.

**6.9.2.11** A forced response analysis shall generate the maximum torque and, in case of a transient forced response analysis, a torque vs time history for each of the shafts in the train.

The maximum torques shall be used to evaluate the peak torque capability of coupling components, gearing and interference fits of components, such as coupling hubs, and shaft locations with stress raisers such as keyways. The torque vs time history shall be used to develop a cumulative damage-fatigue analysis of shafting, keys, and coupling components.

**6.9.2.12** Appropriate fatigue properties and stress concentrations shall be used.

**6.9.2.13** An appropriate cumulative fatigue algorithm shall be used to develop a value for the safe number of starts and/or short-circuit events. The purchaser and vendor shall mutually agree as to the safe number of such events.

NOTE Values used depend on the analytical model used and the vendor's experience. Values of 1000 to 1500 starts are common. API 541 requires 5000 starts, which is a reasonable assumption for a motor. The driven equipment, however, would be overdesigned to meet this requirement.

### 6.9.3 Balancing

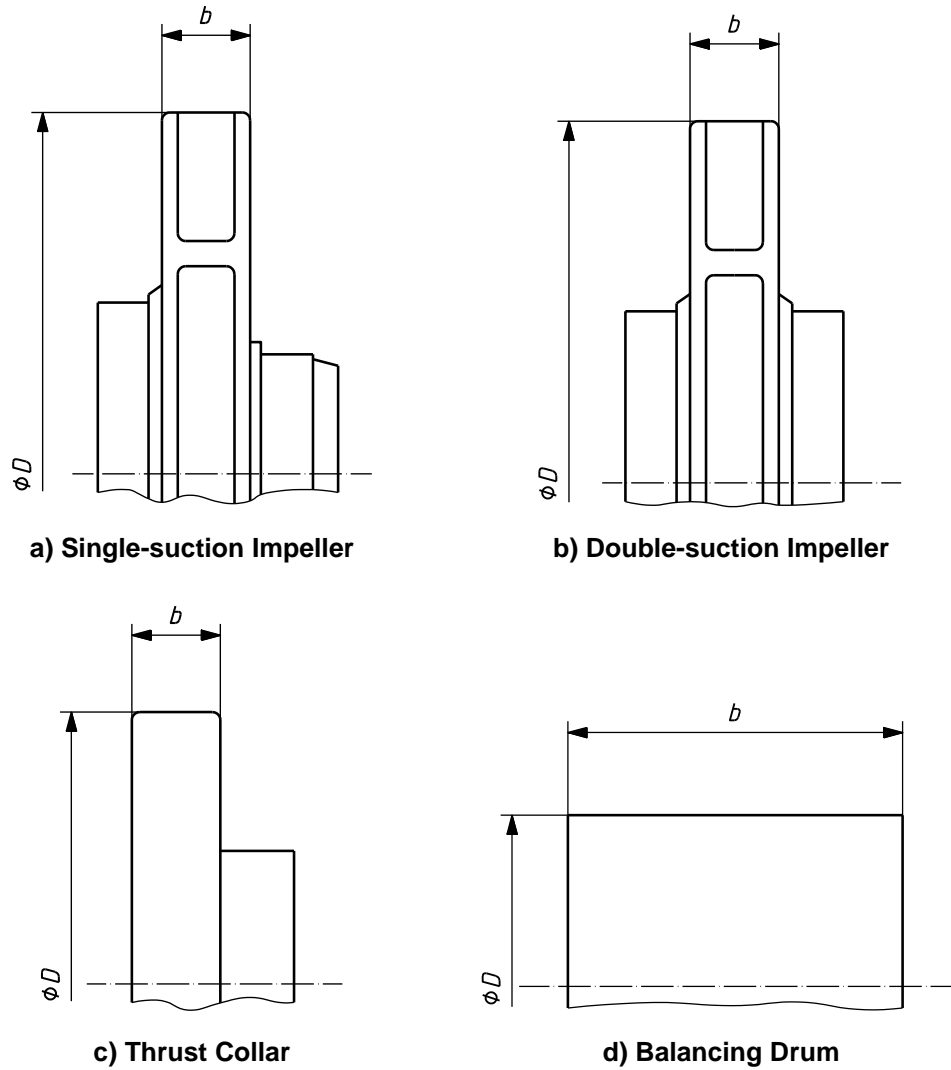
**6.9.3.1** Impellers, balancing drums, and similar major rotating components shall be dynamically balanced to ISO 21940-11, Grade G2.5. The mass of the arbor used for balancing shall not exceed the mass of the component being balanced. Shafts are not required to be balanced. For single-stage BB1 and BB2 pump rotors with interference fit components, the vendor may choose to balance the assembled rotor (in accordance with 9.2.4.2) instead of balancing major rotating components individually.

NOTE In ISO 21940-11 standards, unbalance is expressed as a balance quality grade. Each of the ISO balance quality grades covers a range of unbalance. The nominal equivalent USC unit limits given throughout this standard correspond approximately to the midpoint of the ISO range.

**6.9.3.2** Component balancing may be single-plane if the ratio  $D/b$  (see Figure 30) is 6 or greater.

**6.9.3.3** Rotor balancing shall be performed as required in the specific pump sections.

- **6.9.3.4** If specified, impellers, balancing drums, and similar rotating components shall be dynamically balanced to ISO 21940-11, Grade G1.

**Key**

- $b$  width  
 $D$  diameter

**Figure 30—Rotating Component Dimensions to Determine if Single-plane Balancing Is Allowable**

- **6.9.3.5** If specified, impellers, balancing drums, and similar rotating components shall be dynamically balanced to:

$$U = 4W/n$$

In USC units where

- $U$  is the unbalance per plane, expressed in ounce-inches;
- $W$  is the component mass (for components), expressed in pounds; or the load per balancing machine journal (for rotors), expressed in pounds;
- $n$  is the rotational speed of the pump, expressed in revolutions per minute.

**NOTE**  $4W/n$  is a balance tolerance denominated solely in USC units. With modern balancing machines, it is feasible to balance components mounted on their arbors to  $U = 4W/n$  (USC units), or even lower depending upon the mass of the assembly, and to verify the unbalance of the assembly with a residual unbalance check. However, balancing to ISO Grade G1 or  $U = 4W/n$  (USC units) is generally not repeatable when the components are dismantled and remounted on their arbors, because of the minute mass eccentricity values associated with these fine levels of unbalance requirements. See 9.2.4.2.2.

## 6.9.4 Vibration

**6.9.4.1** Centrifugal pump vibration varies with flow, usually being a minimum in the vicinity of BEP flowrate and increasing as flow is increased or decreased. The change in vibration as flow is varied from BEP flowrate depends upon the pump's energy density, its specific speed, and its suction-specific speed. In general, the change in vibration increases with increasing energy density, higher specific speed, and higher suction-specific speed.

With these general characteristics, a centrifugal pump's operating flow range can be divided into two regions, one termed the preferred operating region, over which the pump exhibits low vibration, the other termed the allowable operating region, with the limits both high and low, defined as those flowrates at which the pump's vibration reaches a higher but still "acceptable" level. Figure 31 illustrates the concept. Factors other than vibration, e.g. temperature, rise with decreasing flow, or NPSH3 with increasing flow, can dictate a narrower allowable operating region.

The allowable operating region shall be stated in the proposal. If the allowable operating region is limited by a factor other than vibration, that factor shall also be stated in the proposal.

**6.9.4.2** During the performance test, overall vibration measurements over a frequency range of 5 Hz to 1000 Hz and discrete vibration measurements using fast Fourier transform (FFT) spectra shall be made at a minimum of five test points. These points shall include the rated flow point and the points defining the minimum and maximum flows for the allowable and preferred operating ranges. Vibration measurements are not required at shutoff. Vibration measurements shall be made at the following locations:

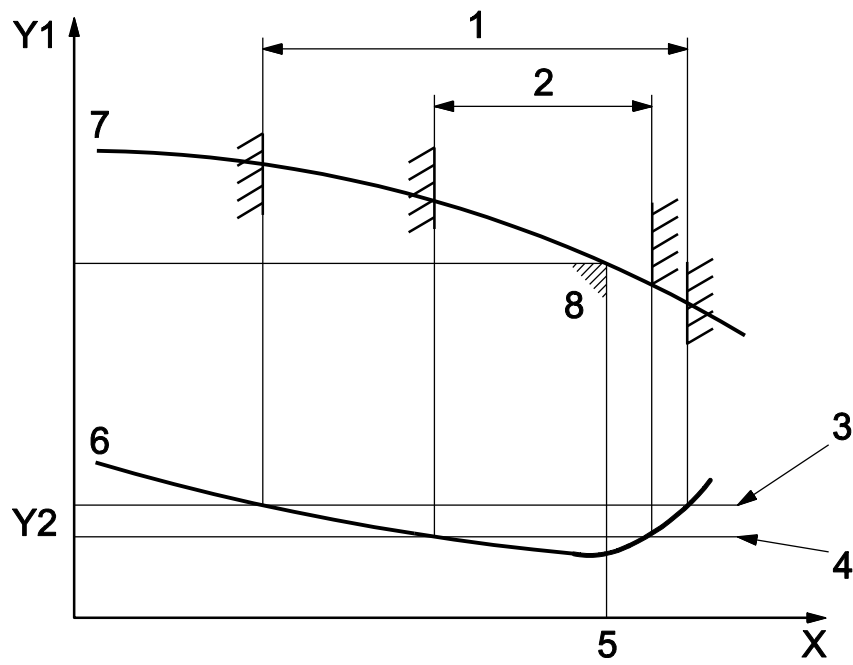
- a) on the bearing housing(s) or equivalent location(s) of all pumps, at the positions shown on Figure 32, Figure 33, and Figure 34 (it is recommended that vibration readings be taken in both horizontal and vertical planes at the rated point and at all other points in the same plane as the higher reading);
- b) on the shaft of pumps with hydrodynamic bearings both X and Y, if the pump has provisions for proximity probes.

**6.9.4.3** The FFT spectra shall include the range of frequencies from 5 Hz to  $2Z$  times running speed (where  $Z$  is the number of impeller vanes; in multistage pumps with different impellers,  $Z$  is the highest number of impeller vanes in any stage). The plotted spectra shall be included with the pump test results.

**NOTE** The discrete frequencies 1.0, 2.0, and  $Z$  times running speed are associated with various pump phenomena and are, therefore, of particular interest in the spectra.

**6.9.4.4** Bearing-housing overall vibration measurements shall be made in root mean square (RMS) velocity, expressed in inches per second (millimeters per second).

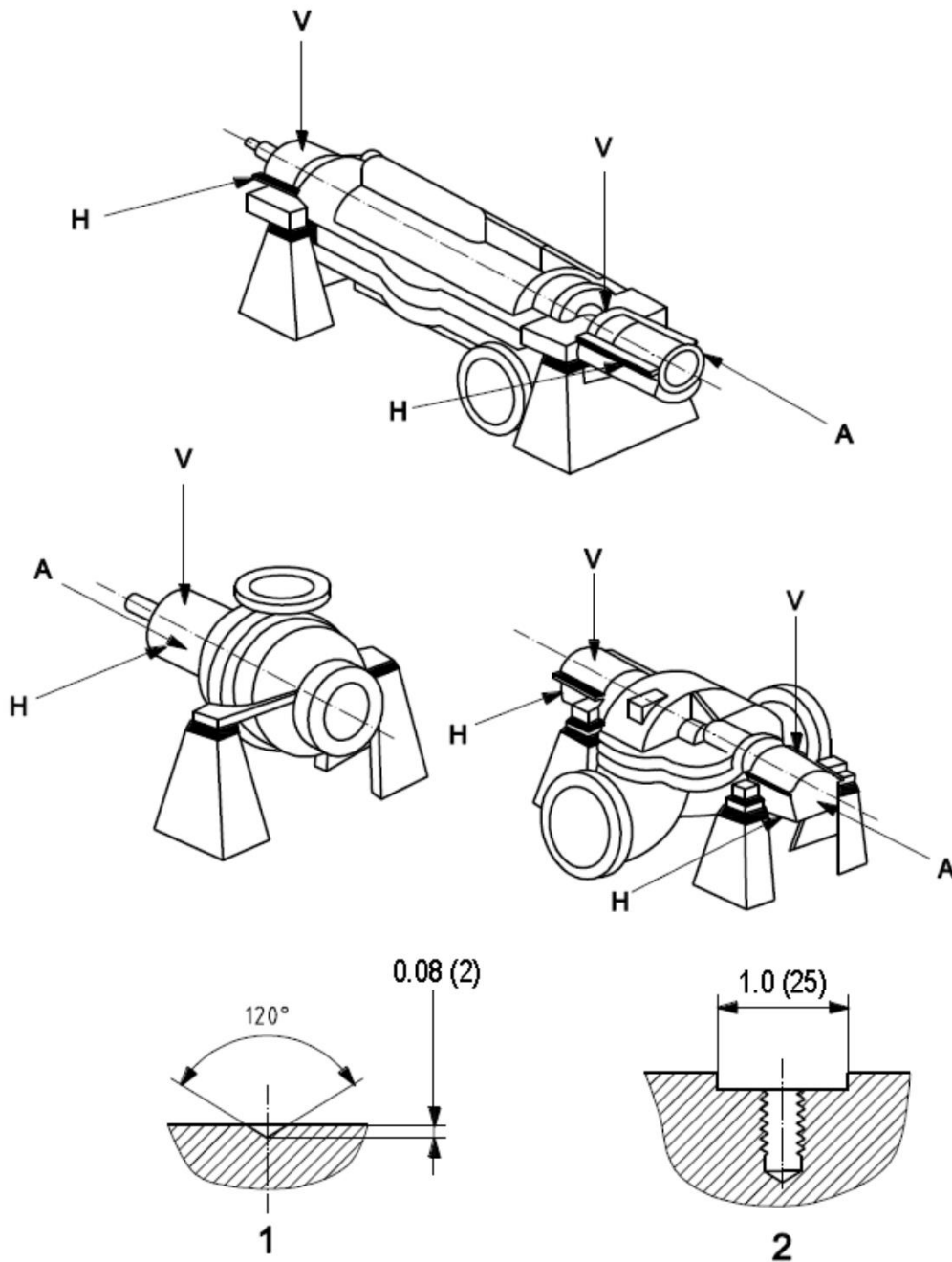
**6.9.4.5** Shaft vibration measurement shall be peak-to-peak displacement, in mils (micrometers).

**Key**

- X flowrate
- Y1 head
- Y2 vibration
- 1 allowable operating region of flow
- 2 preferred operating region of flow
- 3 maximum allowable vibration limit at flow limits
- 4 basic vibration limit
- 5 best efficiency point, flowrate
- 6 typical vibration vs flowrate curve showing maximum allowable vibration
- 7 head-flowrate curve
- 8 best efficiency point, head and flowrate

**Figure 31—Relationship Between Flow and Vibration**

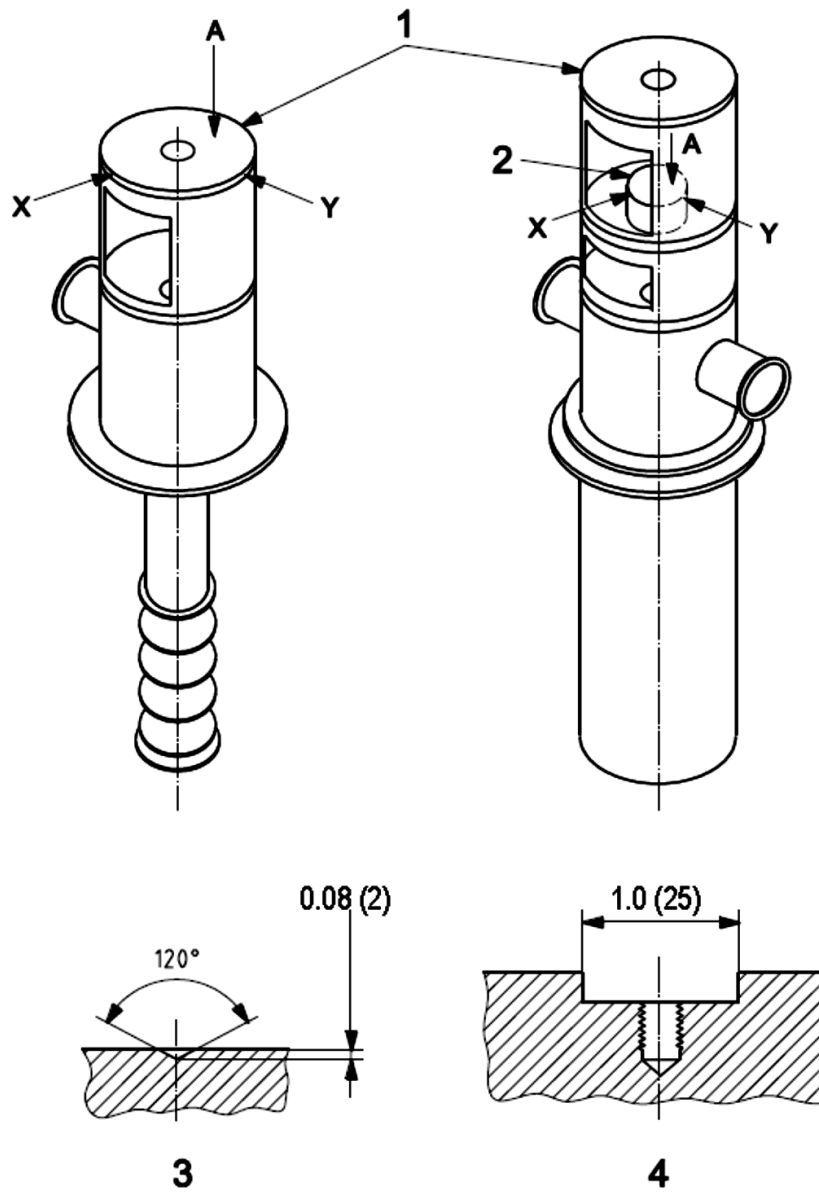
Dimensions in inches (millimeters)

**Key**

- 1 dimple (see 6.10.2.12)
- 2 optional arrangement for mounting vibration-measuring equipment (see 6.10.2.13)
- A axial
- H horizontal
- V vertical

**Figure 32—Locations for Taking Vibration Readings on OH and BB Type Pumps**

Dimensions in inches (millimeters)

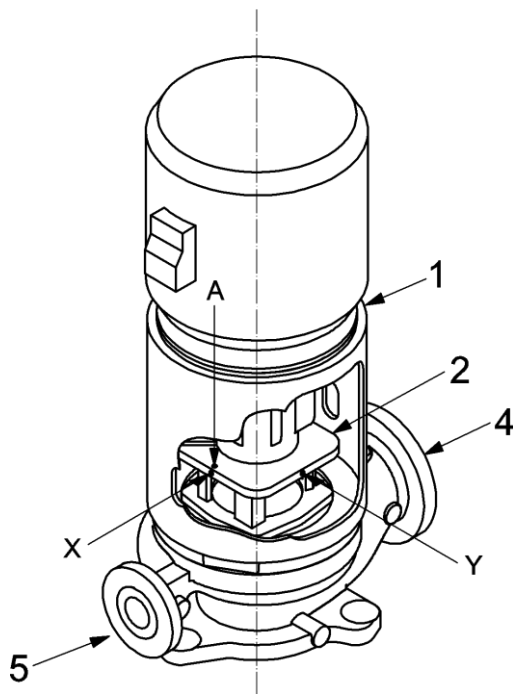
**Key**

- 1 driver mounting surface
- 2 pump bearing housing
- 3 dimple (see 6.10.2.12)
- 4 optional arrangement for mounting vibration-measuring equipment (see 6.10.2.13)
- A axial

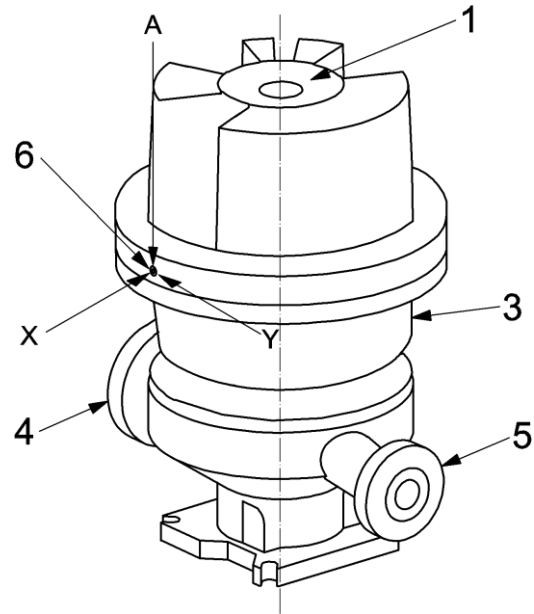
**Figure 33—Locations for Taking Vibration Readings on Vertically Suspended (VS) Pumps**



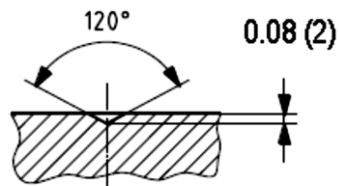
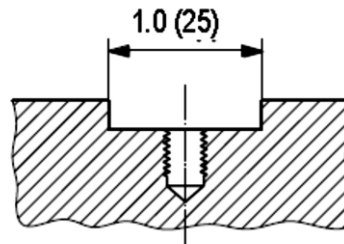
Dimensions in inches (millimeters)



a) Vertical In-line (OH3) Pump



b) High-speed Integally Geared (OH6) Pump

c) Dimples  
(see 6.10.2.12)d) Arrangement for Mounting  
Vibration-measuring Equipment  
(see 6.10.2.13)**Key**

- 1 driver mounting surface
- 2 pump bearing housing
- 3 gearbox housing
- 4 suction flange
- 5 discharge flange
- 6 threaded connection for stud-mounting vibration sensor
- A axial

**Figure 34—Locations for Taking Vibration Readings on Vertical In-line (OH3) and High-speed Integally Geared (OH6) Pumps**

**6.9.4.6** The vibration measured during the performance test shall not exceed the values shown in the following:

- a) Table 8 for overhung and between-bearing pumps,
- b) Table 9 for vertically suspended pumps,
- c) Figure 35 for high-energy pumps.

Pumps furnished with proximity probes shall meet both bearing-housing and shaft-vibration limits.

NOTE Bearing housing overall vibration limits are defined for RMS measurements only.

**Table 8—Vibration Limits for Overhung and Between-bearings Pumps**

Criteria	Location of Vibration Measurement	
	Bearing housing (see Figure 32 and Figure 34)	Pump shaft (adjacent to bearing)
	Pump Bearing Type	
	All	Hydrodynamic journal bearings
	Vibration at Any Flowrate Within the Pump's Preferred Operating Region	
Overall	For pumps running at up to 3600 r/min and absorbing up to 400 hp (300 kW) per stage: $v_u < 0.12$ in./s RMS (3.0 mm/s RMS)	$A_u < (8000/n)^{0.5}$ mils peak-to-peak $(5.2 \times 10^6/n)^{0.5}$ $\mu$ m peak-to-peak  Not to exceed: $A_u < 2.0$ mils peak-to-peak 50 $\mu$ m peak-to-peak
Discrete frequencies	For pumps running at up to 3600 r/min and absorbing up to 400 hp (300 kW) per stage: $v_f < 0.08$ in./s RMS (2.0 mm/s RMS)	for $f < n$ : $A_f < 0.33A_u$
Allowable increase in vibration at flows outside the preferred operating region but within the allowable operating region	30 %	30 %
<p>Power calculated for BEP of rated impeller with liquid relative density (specific gravity) equal to 1.0.</p> <p>Vibration velocity and amplitude values calculated from the basic limits shall be rounded off to two significant figures, where</p> <p><math>v_u</math> is the measured overall velocity;</p> <p><math>v_f</math> is the discrete frequency velocity, measured with a FFT spectrum using a Hanning window and a minimum frequency resolution of 400 lines;</p> <p><math>A_u</math> is the amplitude of measured overall displacement;</p> <p><math>A_f</math> is the amplitude of displacement at discrete frequencies, measured with a FFT spectrum using a Hanning window and a minimum frequency resolution of 400 lines;</p> <p><math>f</math> is the frequency;</p> <p><math>n</math> is the rotational speed, expressed in revolutions per minute.</p> <p>For pumps running above 3600 r/min or absorbing more than 400 hp (300 kW) per stage, see Figure 35.</p>		

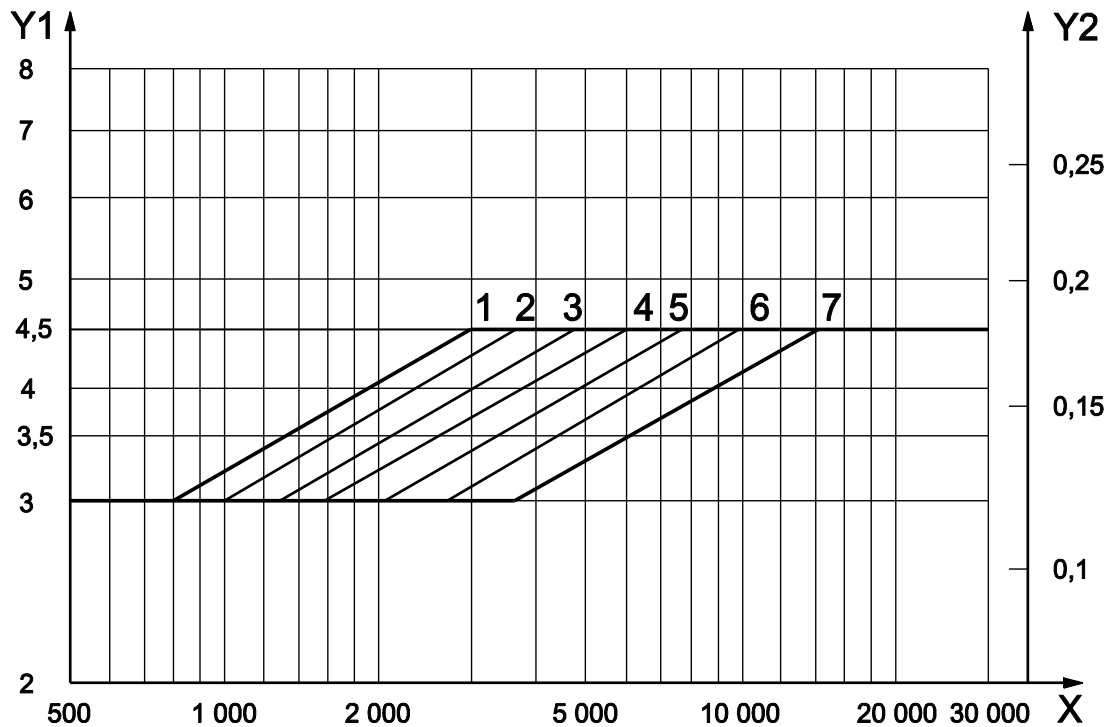
**Table 9—Vibration Limits for Vertically Suspended Pumps**

Criteria	Location of Vibration Measurement	
	Pump thrust bearing housing or motor mounting flange (see Figure 33)	Pump shaft (adjacent to bearing)
	Pump Bearing Type	
	All	Hydrodynamic guide bearing adjacent to accessible region of shaft
	Vibration at Any Flow Within the Pump's Preferred Operating Region	
Overall	$v_u < 0.20$ in./s RMS (5.0 mm/s RMS)	$A_u < (10,000/n)^{0.5}$ mils peak-to-peak < $(6.2 \times 10^6/n)^{0.5}$ $\mu$ m peak-to-peak  Not to exceed: $A_u < 4.0$ mils peak-to-peak (100 $\mu$ m peak-to-peak)
Discrete frequencies	$v_f < 0.13$ in./s RMS (3.4 mm/s RMS)	For $f < n$ : $A_f < 0.33A_u$
Allowable increase in vibration at flows outside the preferred operating region but within the allowable operating region	30 %	30 %
Vibration velocity and amplitude values calculated from the basic limits shall be rounded off to two significant figures, where		
$v_u$ is the measured overall velocity; $v_f$ is the discrete frequency velocity; $A_u$ is the amplitude of measured overall displacement; $A_f$ is the amplitude of displacement at discrete frequencies, measured with a FFT spectrum using a Hanning window and a minimum frequency resolution of 400 lines; $n$ is the rotational speed, expressed in r/min.		

**6.9.4.7** At any speed greater than the maximum continuous speed, up to and including the trip speed of the driver, the vibration shall not exceed 150 % of the maximum value recorded at the maximum continuous speed. Vibration exceeding this limit, but below the allowable limit in the table may be accepted with purchaser's approval.

**6.9.4.8** Variable-speed pumps shall operate over their specified speed range without exceeding the vibration limits of this standard.

**6.9.4.9** If the vendor can demonstrate that electrical or mechanical runout is present, the demonstrated amount of runout can be vectorially subtracted from the measured vibration during the factory test as long as it does not exceed 25 % of the allowed peak-to-peak vibration amplitude or 0.25 mil (6.5  $\mu$ m), whichever is less.



### Key

- X rotational speed,  $n$  expressed in revolutions per minute  
 Y1 vibrational velocity,  $v_u$  expressed in millimeters per second, RMS  
 Y2 vibrational velocity,  $v_u$  expressed in inches per second, RMS
- 1  $P \geq 3000$  kW/stage
  - 2  $P = 2000$  kW/stage
  - 3  $P = 1500$  kW/stage
  - 4  $P = 1000$  kW/stage
  - 5  $P = 700$  kW/stage
  - 6  $P = 500$  kW/stage
  - 7  $P \leq 300$  kW/stage

NOTE 1 The equation for transition from 3.0 mm/s to 4.5 mm/s is:  $v_u = 3.0(n/3600)^{0.30} [P/300]^{0.21}$ .

NOTE 2 The allowable vibration limit for discrete frequencies is:  $v_f < 0.67v_u$  from Figure 35.

**Figure 35—Bearing Housing Vibration Limits for Horizontal Pumps Running Above 3600 r/min or Absorbing More Than 400 hp (300 kW) per Stage**

## 6.10 Bearings and Bearing Housings

### 6.10.1 Bearings

- **6.10.1.1** Each shaft shall be supported by two radial bearings and one double-acting axial (thrust) bearing. If the pump has rolling-element radial and thrust bearings, the thrust bearing carries both the radial load on one end of the rotor and the axial thrust transmitted by the pump to the rotor. If the pump has hydrodynamic radial bearings and a rolling-element thrust bearing, the rolling-element bearing carries axial thrust only; the hydrodynamic bearings carry only radial loads. For higher loads and/or speeds, the hydrodynamic radial bearings carry all the radial loads and the hydrodynamic thrust bearing carries all the axial load.

Bearings, therefore, shall be one of the following arrangements:

- a) rolling-element radial and thrust;
- b) hydrodynamic radial and rolling-element thrust;
- c) hydrodynamic radial and thrust.

**6.10.1.2** Unless otherwise specified or approved by the purchaser, the bearing type and arrangement shall be selected in accordance with the limitations in Table 10.

**6.10.1.3** For pumps that will be installed in oilfield and pipeline applications, rolling-element radial and/or thrust bearings may be applied exceeding Table 10 limits up to the manufacturer's favorable experience limits with purchaser's approval.

**Table 10—Bearing Selection**

Condition	Bearing Type and Arrangement
Radial and thrust bearing speed and life within limits for rolling-element bearings and Pump energy density below limit	Rolling-element radial and thrust
Radial bearing speed or life outside limits for rolling-element bearings and Thrust bearing speed and life within limits and Pump energy density below limit	Hydrodynamic radial and rolling-element thrust
Radial and thrust bearing speed or life outside limits for rolling-element bearings or Pump energy density above limit	Hydrodynamic radial and thrust
<p>Limits are as follows.</p> <p>a) Rolling-element bearing speed: For all bearing types, the bearing manufacturer's published nominal speed limitations shall not be exceeded. For back-to-back 40 degree (0.7 rad) angular contact ball bearings, factor <math>nd_m</math> for individual bearings shall not exceed 500,000 for oil-lubricated and 350,000 for grease-lubricated bearings, where  <math>d_m</math> is the mean bearing diameter <math>[(d + D)/2]</math>, expressed in millimeters;  <math>n</math> is the rotational speed, expressed in revolutions per minute.</p> <p>NOTE 1 The bearing temperature limits in 6.10.2.7 can limit <math>nd_m</math> factors to even lower values.  NOTE 2 Roller and spherical bearings generally have lower speed limitations than ball bearings.</p> <p>b) Rolling-element bearing life shall be determined in accordance with 6.10.1.10 or 6.10.1.11.</p> <p>c) For non-pipeline pumps, hydrodynamic radial and thrust bearings shall be used if the energy density [i.e. the product of pump rated power, hp (kW), and rated speed, r/min] is <math>5.4 \times 10^6</math> hp/min (<math>4.0 \times 10^6</math> kW/min) or greater.</p> <p>d) For pipeline pumps, hydrodynamic radial and thrust bearings shall be used if the energy density is greater than <math>10.7 \times 10^6</math> hp/min (<math>8.0 \times 10^6</math> kW/min).</p> <p>e) For pipeline pumps, with energy density values between <math>5.4 \times 10^6</math> hp/min (<math>4.0 \times 10^6</math> kW/min) and <math>10.7 \times 10^6</math> hp/min (<math>8.0 \times 10^6</math> kW/min), hydrodynamic radial bearings shall be used with either rolling-element or hydrodynamic thrust bearings.</p>	

**6.10.1.4** Thrust bearings shall be sized for continuous operation under all specified conditions, including maximum differential pressure, and comply with the following.

- a) All loads shall be determined at design internal clearances and also at twice design internal clearances.
- b) Thrust forces for flexible metal-element couplings shall be calculated on the basis of the maximum allowable deflection permitted by the coupling manufacturer.
- c) If a sleeve-bearing motor (without a thrust bearing) is directly connected to the pump shaft with a coupling, the coupling-transmitted thrust shall be assumed to be the maximum motor thrust.
- d) In addition to thrust from the rotor and any internal gear reactions due to the most extreme allowable conditions, the axial force transmitted through flexible couplings shall be considered a part of the duty of any thrust bearing.
- e) If specified, the angular contact thrust bearing may be mounted on a removable sleeve that is retained on the shaft by a locking nut and tab washer.

NOTE This arrangement allows the thrust bearing to be easily removed for mechanical seal maintenance and then be reused.

**6.10.1.5** Rolling-element bearings shall not have filling slots.

**6.10.1.6** Rolling-element bearings shall not have nonmetallic cages.

**6.10.1.7** Single-row, deep-groove ball bearings shall have a radial internal clearance in accordance with ABMA 20, Group 3 (larger than "N" or Normal internal clearance). Greater internal clearances can reduce the temperature rise of the lubricant. However, vibration velocities can be increased with greater clearances. The vendor shall ensure that the values for temperature rise and vibration meet the requirements of this standard.

NOTE For the purpose of this provision, ISO 5753, Group 3 is equivalent to ABMA 20, Group 3.

**6.10.1.8** Ball thrust bearings shall be of the paired, single-row, 40° (0.7 rad) angular contact type (7000 series) with machined brass cages. Pressed steel cages may be used if approved by the purchaser. Unless otherwise specified, bearings shall be mounted in a paired arrangement installed back-to-back. The need for bearing clearance or preload shall be determined by the vendor to suit the application and meet the bearing life requirements of this standard.

NOTE There are applications where alternative bearing arrangements can be preferable, particularly where bearings operate continuously with minimal axial loads.

**6.10.1.9** If loads exceed the capability of paired, angular-contact bearings as described in 6.10.1.10, alternative rolling-element arrangements may be proposed.

**6.10.1.10** Rolling-element bearing life (basic rating life,  $L_{10h}$ , for each bearing or bearing pair) shall be calculated in accordance with ABMA 9 (ISO 281).

NOTE 1 ABMA 9 defines basic rating life,  $L_{10}$ , in units of millions of revolutions. Industry practice is to convert this to hours and to refer to it as  $L_{10h}$ .

NOTE 2 For the purpose of this provision, ISO 281 is equivalent to ABMA 9.

- **6.10.1.11** Bearing system life (the calculated life of the combined system of bearings in the pump) shall be equivalent to at least 25,000 h with continuous operation at rated conditions, and at least 16,000 h at maximum radial and axial loads and rated speed. The system life shall be calculated as given in Equation (3):

$$L_{10h,system} = \left[ \left( \frac{1}{L_{10hA}} \right)^{3/2} + \left( \frac{1}{L_{10hB}} \right)^{3/2} + \dots + \left( \frac{1}{L_{10hN}} \right)^{3/2} \right]^{-2/3} \quad (3)$$

where

$L_{10hA}$  is the basic rating life,  $L_{10h}$ , in accordance with ABMA 9 for bearing A;

$L_{10hB}$  is the basic rating life,  $L_{10h}$ , in accordance with ABMA 9 for bearing B;

$L_{10hN}$  is the basic rating life,  $L_{10h}$ , in accordance with ABMA 9 for bearing  $N$ ;

$N$  is the number of bearings.

If specified, the bearing system life calculations shall be furnished. See K.2 for a discussion of bearing system life.

NOTE A bearing system  $L_{10h}$  life of 25,000 h and 16,000 h requires that the  $L_{10h}$  life of each individual bearing be significantly higher. Further to meet these requirements, two bearings would each have to have an  $L_{10h}$  of about 40,000 h.

**6.10.1.12** Rolling-element bearings shall be located, retained, and mounted in accordance with the following.

- a) Bearings shall be retained on the shaft with an interference fit and fitted into the housing with a diametral clearance, both in accordance with ABMA 7.

NOTE For rolling-element thrust bearings in pure axial loading, some users prefer a bearing fit on the shaft of 0.0005 in. (0.01 mm) loose in order to ease bearing replacement.

- b) Bearings shall be mounted directly on the shaft, if not otherwise specified [see 6.10.1.4 f)].
- c) Bearings shall be located on the shaft using shoulders, collars or other positive locating devices. Snap rings and spring-type washers are not acceptable.
- d) The device used to lock thrust bearings to shafts shall be restricted to a nut with a tongue-type lock washer.

NOTE This subsection applies to all rolling-element bearings, including both ball and roller types. For certain roller bearings, such as cylindrical roller types with separable races, bearing-to-housing diametral clearances in accordance with ABMA 7 are not be appropriate.

## 6.10.2 Bearing Housings

**6.10.2.1** Bearing housings shall be arranged so that bearings can be replaced without disturbing pump drives or mountings.

- **6.10.2.2** If specified, bearing housings shall have provisions to measure bearing metal temperatures.

**6.10.2.3** Bearing housings for oil-lubricated non-pressure-fed bearings shall be provided with the following features:

- a) threaded and plugged fill and drain connections of at least NPS 1/2 (DN 15);
- b) means, such as a bulls-eye or an overflow plug for detecting overfilling of the housings;
- c) if a sight glass or bulls-eye is provided, it shall be located such that the proper oil level elevation is at the midpoint (at 50 % up or down the viewing area);
- d) a permanent indication of the proper oil level shall be accurately located and clearly marked on the outside of the bearing housing with permanent metal tags, marks inscribed in the castings, or other durable means;
- e) a bearing housing vent to atmosphere, which may be located at the fill connection;

- f) a “vented to atmosphere” constant-level sight feed oilers at least 4 fl oz (1.2 dl) in volume, heat-resistant glass containers and protective wire cages.
- **6.10.2.4** If specified, bearing housings for oil-lubricated non-pressure-fed bearings shall be provided with a “vented to bearing housing” constant level oiler in lieu of a “vented to atmosphere” constant level oiler.
  - **6.10.2.5** If specified, bearing housings for oil-lubricated non-pressure-fed bearings shall be provided with an oil sump collection container. This container shall be transparent and shall be located on the bottom of the oil sump to collect bearing housing contaminants such as water. It shall be fitted with a spring-loaded drain pet cock. The collector materials of construction shall be suitable for the lubricant used.
- 6.10.2.6** Bearing housings for pressure-lubricated hydrodynamic bearings shall be arranged to minimize foaming. The drain system shall be adequate to maintain the oil and foam level below shaft end seals.
- 6.10.2.7** Sufficient cooling, including an allowance for fouling, shall be provided to maintain oil and bearing temperatures as follows during shop testing and in field operation under the most adverse specified operating condition:
- a) for pressurized systems, the bearing-oil temperature rise shall not exceed 50 °F (28 K), and if bearing-temperature sensors are supplied, bearing metal temperatures shall not exceed 200 °F (93 °C);
  - b) for ring-oiled or splash systems (including such systems with purge-oil mist), the sump oil temperature rise shall not exceed 70 °F (39 K) above the ambient temperature, and if bearing-temperature sensors are supplied, bearing metal temperatures shall not exceed 200 °F (93 °C);
  - c) for pure oil mist pump, the bearing housing surface temperature shall not exceed 160 °F (71 °C), and if bearing-temperature sensors are supplied, bearing metal temperatures shall not exceed 190 °F (88 °C).

NOTE 1 Pumps equipped with ring-oiled or splash lubrication systems normally do not reach temperature stabilization during performance tests of short duration and sometimes longer. Temperature-stabilization testing is addressed in 8.3.4.2.1.

NOTE 2 For oil sump temperatures higher than 170 °F (77 °C), the additives in the oil will deteriorate and coke formation will accelerate.

NOTE 3 In some installations, solar radiation can cause bearing housing temperature to be higher than specified above. In those cases, measuring bearing metal temperature directly can be useful.

**6.10.2.8** If cooling with water or product is required, tube-type cooling is preferred. The tube (including fittings) shall be of nonferrous material or austenitic stainless steel and shall have no internal pressure joints. Tubing or pipe shall have a minimum thickness of 0.040 in. (1.0 mm) and shall be at least 0.50 in. (12 mm) OD. Water jackets, if used, shall have only external connections between upper and lower housing jackets and shall have neither gasketed nor threaded connection joints that could allow cooling liquid to leak into the oil reservoir. Water jackets shall be designed to cool the oil rather than the outer bearing ring.

NOTE Cooling the outer ring of rolling-element bearings can reduce bearing internal clearance and cause bearing failure.

**6.10.2.9** Bearing housings for rolling-element bearings shall be designed to prevent contamination by moisture, dust, and other foreign matter. This shall be achieved without the requirement for external service, e.g. air purge. Bearing housings shall be equipped with replaceable labyrinth-type or magnetic-type end seals and deflectors where the shaft passes through the housing. Lip-type seals shall not be used. The seals and deflectors shall be made of spark-resistant materials. The design of the seals and deflectors shall effectively retain oil in the housing and prevent entry of foreign material into the housing.

NOTE Many users consider pure aluminum and aluminum alloys with a maximum content of 2 % magnesium or 0.2 % copper, all copper, and copper-based alloys (e.g. brass, bronze) to be spark-resistant. However, local standards, such as EN 13463-1, might not allow aluminum or nonmetallic materials within potentially explosive atmospheres.

**6.10.2.10** If oil-mist lubrication is specified, the requirements of 6.10.2.10.1 or 6.10.2.10.2 shall apply.



**6.10.2.10.1** For pure oil-mist lubrication, bearings and bearing housings shall meet the following requirements:

- a) a threaded 6 mm (NPS  $\frac{1}{4}$ ) oil-mist inlet connection shall be provided on the housing or end cover for each of the spaces between the rolling-element bearing or bearing set and the bearing housing end seal;
- b) oil-mist fitting connections shall be located so that oil mist can flow through rolling-element bearings;
- c) oil rings or flingers and constant-level oilers shall not be provided, and a mark indicating the oil level is not required;
- d) drain-back and any other (feed hole) oil passages in the bearing housing shall be plugged to prevent the oil mist from bypassing the bearings(s);
- e) water cooling systems shall not be provided.

NOTE 1 Reclassifiers and oil-mist fittings are normally installed in the field.

NOTE 2 At process operating temperatures above 570 °F (300 °C), bearing housings with pure oil-mist lubrication can require special features to reduce heating of the bearing races by heat transfer. Typical features are:

- heat sink type flingers,
- stainless steel shafts having low thermal conductivity,
- thermal barriers,
- fan cooling,
- purge oil-mist lubrication (in place of pure oil mist) with oil (sump) cooling.

**6.10.2.10.2** For purge oil-mist lubrication, bearings and bearing housings shall meet the following requirements.

- a) A threaded NPS  $\frac{1}{4}$  or  $\frac{1}{2}$  (6 mm or 12 mm) oil-mist connection shall be located in the top half of the bearing housing to act also as a vent-and-fill connection.
- b) Constant-level oilers shall be provided, and a mark indicating the oil level is required on the bearing housing. Bearing lubrication is by a conventional oil bath, flinger, or oil ring system.
- c) Constant-level sight feed oilers shall be equipped with overflow control to allow excess coalesced oil from the mist system to drain from the bearing housing so that oil level in the sump is maintained at proper level. The oil shall be contained to prevent it from draining onto the baseplate.
- d) Constant-level sight feed oilers shall be piped so that they operate at the internal pressure of the bearing housing, do not vent excess mist at the bearing housing, or allow oil to drip to the baseplate.

**6.10.2.10.3** For both pure and purge mist applications, a drain connection shall be located on the bottom of the bearing housing to provide complete oil drainage (see 6.10.2.10.5).

**6.10.2.10.4** Shielded or sealed bearings shall not be used in conjunction with either pure or purge oil-mist systems.

**6.10.2.10.5** The oil-mist supply, reclassifier and drain fittings shall be provided by the purchaser. Unless otherwise specified, directional reclassifiers, if required, shall be provided by the machine manufacturer.

**6.10.2.11** Housings for ring oil-lubricated bearings shall be provided with (plugged) ports positioned to allow visual inspection of the oil rings while the pump is running.

**6.10.2.12** All bearing housings shall be dimpled at the locations shown on Figure 32, Figure 33, and Figure 34 to facilitate consistent-vibration measurements. The dimples shall be suitable for accurate location of a hand-held vibration transducer with an extension wand. Dimples shall be either cast or machined and shall be nominally 0.080 in. (2 mm) deep with an included angle of 120°.

- **6.10.2.13** If specified, bearing housings shall have a threaded connection(s) for permanently mounting vibration transducers in accordance with API 670. If metric fasteners are supplied, the threads shall be M8 × 1.25. See Figure 32, Figure 33, and Figure 34.
- **6.10.2.14** If specified, a flat surface at least 1 in. (25 mm) in diameter shall be supplied for the location of magnetic-based vibration-measuring equipment.

**6.10.2.15** Bearing housings, bearing housing covers, and bearing housing brackets shall be steel.

## 6.11 Lubrication

**6.11.1** Unless otherwise specified, bearings and bearing housings shall be designed for oil lubrication using a mineral (hydrocarbon) oil in accordance with ASTM D4304 or ISO 8068 type AR.

**6.11.2** The operation and maintenance manual shall describe how the lubrication system circulates oil.

- **6.11.3** If specified, provisions shall be made for either pure oil-mist or purge oil-mist lubrication (see 6.10.2.10 for requirements).
- **6.11.4** If specified, rolling-element bearings shall be grease-lubricated in accordance with the following:
  - a) grease life (re-lubrication interval) shall be estimated using the method recommended by the bearing manufacturer or an alternative method approved by the purchaser;
  - b) grease lubrication shall not be used if the estimated grease life is less than 2000 h;
  - c) if the estimated grease life is 2000 h or greater but less than 25,000 h, provision shall be made for re-greasing the bearings in service and for the effective discharge of old or excess grease, and the vendor shall advise the purchaser of the required re-greasing interval;
  - d) if the estimated grease life is 25,000 h or more, grease nipples or any other system for the addition of grease in service shall not be fitted.
- **6.11.5** The purchaser shall specify whether synthetic oil shall be used. If specified, the purchaser shall specify the oil type. The vendor shall ensure that bearing-housing internal paint, if used, is compatible with the specified oil.

## 6.12 Materials

### 6.12.1 General

- **6.12.1.1** The purchaser shall specify the material class for pump parts from Annex H, Table H.1. Annex G, Table G.1 provides a guide showing material classes that can be appropriate for various services. Pump materials shall be in accordance with Table H.1. Alternative materials, including materials that can improve life and performance in service, may also be included in the vendor's proposal and listed on the final data sheets.
- **6.12.1.2** If specified, wear parts of nonmetallic materials from Table H.3 shall be provided. If nonmetallic wear parts are provided, the material class from Table H.1 shall be modified by addition of the letter C, such as S-5C. The nonmetallic material shall be agreed to by the vendor and purchaser.
- **6.12.1.3** The material specification of all components listed in Table H.1 shall be clearly stated in the vendor's proposal. Materials shall be identified by reference to applicable international standards, including the material

grade (Table H.2 and Table H.3 may be used for guidance). If standard materials are not available, then national standards may be used. If no such designations are available, the vendor's material specification, giving physical properties, chemical composition, and test requirements, shall be included in the proposal.

**6.12.1.4** The material specification of all gaskets and O-rings exposed to the pumped liquid shall be identified in the proposal. O-rings shall be selected and their application limited in accordance with API 682, Annex B.

**6.12.1.5** Pump parts having strength or pressure-integrity requirements are designated as "full compliance" materials in Table H.1 and shall meet all the requirements of the agreed specifications. For any other part (e.g. if corrosion resistance is the primary concern), it is necessary to comply only with the specified chemical composition. Auxiliary piping materials are covered in 7.6.

- **6.12.1.6** Purchasers shall specify optional test and inspection requirements that are necessary to ensure that materials are satisfactory for the service.

**6.12.1.7** If austenitic stainless steel parts exposed to conditions that can promote intergranular corrosion are fabricated, hard-faced, overlaid, or repaired by welding, they shall be made of low-carbon or stabilized grades.

NOTE Overlays or hard surfaces that contain more than 0.10 % carbon can sensitize both low-carbon and stabilized grades of austenitic stainless steel unless a buffer layer that is not sensitive to intergranular corrosion is applied.

- **6.12.1.8** If specified, the vendor shall furnish material certificates that include chemical analysis and mechanical properties for the heats from which the material is supplied for pressure-containing castings and forgings, impellers, and shafts. Unless otherwise specified, piping nipples, auxiliary piping components, gaskets, and bolting are excluded from this requirement.
- **6.12.1.9** The purchaser shall specify any erosive or corrosive agents (including trace quantities) present in the process liquids and in the site environment, including constituents that can cause stress-corrosion cracking or attack elastomers.

NOTE 1 Typical agents of concern are hydrogen sulfide, amines, chlorides, bromides, iodides, cyanides, fluorides, naphthenic acid, and polythionic acid. Other agents affecting elastomer selection include ketones, ethylene oxide, sodium hydroxide, methanol, benzene, and solvents.

NOTE 2 If chlorides are present in the pumped liquid in a concentration above 10 ppm (10 mg/kg), it is necessary to use caution when applying stainless steel.

- **6.12.1.10** If specified, coatings of a type agreed between the purchaser and the vendor shall be applied to impellers and other wetted parts to minimize erosion or to improve efficiency. If coatings are applied to rotating components, the acceptance balance shall be performed after coatings have been applied. The sequence of procedures for balancing and coating of rotating components shall be agreed between the purchaser and the vendor.
- **6.12.1.11** Rotating parts should be balanced before coating in order to minimize balance corrections to coated areas. By minimizing the area to be recoated, a final correction after coating repair might not be required.
- **6.12.1.12** If mating parts, such as studs and nuts of austenitic stainless steel or materials with similar galling tendencies, are used, they shall be lubricated with an anti-seizure compound compatible with the material(s) and specified process liquid(s) operating conditions.

NOTE The torque loading values required to achieve the necessary preload can vary considerably depending upon the thread lubricant.

- **6.12.1.13** The purchaser shall specify the amount of wet H<sub>2</sub>S that can be present, considering normal operation, start-up, shutdown, idle standby, upsets, or unusual operating conditions such as catalyst regeneration.

NOTE In many applications, small amounts of wet H<sub>2</sub>S are sufficient to require materials resistant to sulfide stress-corrosion cracking. If trace quantities of wet H<sub>2</sub>S are known to be present or if there is any uncertainty about the amount of wet H<sub>2</sub>S that can be present, the purchaser can consider specifying that reduced-hardness materials are required.

- **6.12.1.14** The purchaser shall specify if reduced-hardness materials are required. Unless otherwise specified, reduced-hardness materials shall be supplied in accordance with NACE MR0103. If specified, reduced-hardness materials shall be supplied in accordance with NACE MR0175 in lieu of NACE MR0103.

NOTE 1 NACE MR0103 applies to oil refineries, liquefied natural gas (LNG) plants, and chemical plants. NACE MR0103 applies to materials potentially subject to sulfide stress-corrosion cracking.

NOTE 2 For the purposes of this provision, ISO 15156-1 is equivalent to NACE MR0175.

NOTE 3 NACE MR0175 (all parts), applies to material potentially subject to sulfide and chloride stress-corrosion cracking in oil and gas production facilities and natural gas sweetening plants.

**6.12.1.14.1** Reduced-hardness ferrous materials not covered by NACE MR0103 or NACE MR0175 shall have yield strength not greater than 620 N/mm<sup>2</sup> (90,000 psi) and hardness not greater than HRC 22. Components that are fabricated by welding shall be postweld heat treated, if required, so that both the welds and heat-affected zones meet these yield strength and hardness requirements.

**6.12.1.14.2** Reduced hardness materials shall be provided for the following components, as a minimum:

- a) pressure casing,
- b) shafting (including wetted shaft nuts),
- c) pressure-retaining mechanical seal components (excluding the seal ring and mating ring),
- d) wetted bolting,
- e) bowls.

NOTE 1 Double-casing-pump inner-casing parts that are in compression, such as diffusers, are not considered pressure casing parts.

NOTE 2 Casing bolting for pumps with axially split casings (such as BB1 and BB3) are not considered to be wetted.

**6.12.1.14.3** Renewable impeller wear rings that are through-hardened shall not have hardness greater than HRC 22, if reduced-hardness materials are specified. Renewable impeller wear rings that are either hard-coated or surface-hardened may have hardness greater than HRC 22 if their substrate material hardness is not greater than HRC 22.

- **6.12.1.14.4** If approved by the purchaser, integral wear surfaces on the impellers may be surface-hardened or hardened by the application of a suitable coating in lieu of furnishing renewable impeller wear rings.

**6.12.1.15** Low-carbon steels can be notch-sensitive and be susceptible to brittle fracture, even at ambient (room) temperatures. Therefore, only fully killed, normalized steels made to fine-grain practice shall be used.

**6.12.1.16** If dissimilar materials with significantly different electrochemical potentials are placed in contact in the presence of an electrolytic solution, galvanic couples can be created that can result in serious corrosion of the less noble material. The vendor shall select materials to avoid conditions that can result in galvanic corrosion. Where such conditions cannot be avoided, the purchaser and the vendor shall agree on the material selection and any other precautions necessary. See NACE's *Corrosion Engineer's Reference Book* [85] for one source for selection of suitable materials in these situations.

**6.12.1.17** Bearing housings, load-carrying bearing housing covers, and brackets between the pump casings or heads and the bearing housings shall be steel. Driver supports for vertical pumps that utilize thrust bearings in the driver to support the shaft shall be steel.

## **6.12.2 Castings**

**6.12.2.1** Surfaces of castings shall be cleaned by sandblasting, shot blasting, chemical cleaning, or any other standard method to meet the visual requirements of MSS SP-55. Mold-parting fins and remains of gates and risers shall be chipped, filed, or ground flush.

**6.12.2.2** The use of chaplets in pressure castings shall be held to a minimum. The chaplets shall be clean and corrosion-free (plating is permitted) and of a composition compatible with the casting. Chaplets shall not be used in impeller castings.

**6.12.2.3** Ferrous pressure boundary and impeller castings shall not be repaired by peening, plugging, burning in, or impregnating. Weldable grades of steel castings may be repaired by welding in accordance with 6.12.3. Weld repairs shall be inspected according to the same quality standard used to inspect the casting.

**6.12.2.4** Fully enclosed, cored voids that become fully enclosed by methods such as plugging, welding, or assembly shall not be used.

- **6.12.2.5** If specified, for casting repairs made in the vendor's shop, repair procedures including weld maps shall be submitted for purchaser's approval. The purchaser shall specify if approval is required before proceeding with repair. Repairs made at the foundry level shall be controlled by the casting material specification ("producing specification").

**6.12.2.6** Pressure-containing castings of carbon steel shall be furnished in the normalized and tempered or quenched and tempered condition.

## **6.12.3 Welding**

- **6.12.3.1** Welding and weld repairs shall be performed by operators and in accordance with procedures qualified to the requirements of Table 11. Alternative standards may be proposed by the vendor for the purchaser's approval. The welding and material inspection data sheet in Annex N may be used for this purpose.

**6.12.3.2** The vendor shall be responsible for the review of all repairs and repair welds to ensure they are properly heat-treated and nondestructively examined for soundness and compliance with the applicable qualified procedures (see 6.12.3.1 and 8.2.2.1, Table 14).

**6.12.3.3** Pressure-containing casings made of wrought materials or combinations of wrought and cast materials shall conform to the conditions specified in Items a) through d) as follows (these requirements do not apply to casing nozzles and auxiliary connections; see 6.12.3.4):

- a) accessible surfaces of welds shall be inspected by magnetic-particle or liquid-penetrant examination after back chipping or gouging and again after PWHT or, for austenitic stainless steels, after solution annealing;
- b) pressure-containing welds, including welds of the casing to axial-joint and radial-joint flanges, shall be full-penetration welds;
- c) if dimensional stability of such a casing component is required for the integrity of pump operation, then PWHT shall be performed regardless of thickness;
- d) plate edges shall be inspected by magnetic-particle or liquid-penetrant examination as required by recognized standards, such as ASME *BPVC*, Section VIII, Division 1, UG-93 (d)(3).

**Table 11—Welding Requirements**

Requirement	Applicable Code or Standard
Welder/operator qualification	ASME <i>BPVC</i> , Section IX or ISO 9606 (all parts)
Welding procedure qualification	Applicable material specification or, where weld procedures are not covered by the material specification, ASME <i>BPVC</i> , Section IX, ASME B31.3, EN 287, ISO 15607, or ISO 15609 (all parts)
Non-pressure-retaining structural welding, such as baseplates or supports	AWS D1.1/D1.1M
Magnetic-particle or liquid-penetrant examination of the plate edges	ASME <i>BPVC</i> , Section VIII, Division 1, UG-93(d)(34)
Postweld heat treatment	Applicable material specification, ASME <i>BPVC</i> , Section VIII, Division 1, UW 40, ASME B31.3, or EN 13445-4
Postweld heat treatment of casing fabrication welds	Applicable material specification, ASME <i>BPVC</i> , Section VIII, Division 1 or EN 13445-4
NOTE For the purpose of this provision, ISO 10721-2 is equivalent to AWS D1.1/D1.1M.	

**6.12.3.4** Connections welded to pressure casings shall be installed as specified in Items a) through d) as follows:

- a) attachment of suction and discharge nozzles shall be by means of full-fusion, full-penetration welds using welding neck flanges and shall not be dissimilar metal weldments;
  - b) auxiliary piping welded to alloy steel casings shall be of a material with the same nominal properties as the casing material (see 6.4.2.6);
  - c) PWHT, if required, shall be carried out after all welds, including piping welds, have been completed;
  - d) suction and discharge nozzle welds shall be inspected by magnetic-particle or liquid-penetrant examination after back chipping or gouging and again after PWHT or, for austenitic stainless steels, after solution annealing.
- **6.12.3.4.1** The purchaser shall specify if the following additional examinations shall be performed on connections welded to pressure casings (if not already required in 8.2.2.1, Table 14):
    - a) magnetic-particle or liquid-penetrant examination of auxiliary connection welds;
    - b) ultrasonic or radiographic examination of any casing welds.
  - **6.12.3.4.2** The purchaser shall specify if the proposed connection design shall be submitted to the purchaser for approval before fabrication. The submittal drawing shall show weld designs, sizes, materials, and pre-weld and postweld heat treatments.

#### **6.12.4 Low-temperature Service**

- **6.12.4.1** The purchaser shall specify the minimum design metal temperature to which the pump will be subjected in service. This temperature shall be used to establish impact test requirements. Normally, this is the lower of the minimum surrounding ambient temperature or minimum liquid pumping temperature. However, the purchaser may specify a minimum design metal temperature based on pump liquid properties, such as auto-refrigeration at reduced pressures.

**6.12.4.2** To avoid brittle failures, materials of construction for low-temperature service shall be suitable for the minimum design metal temperature in accordance with the codes and other requirements specified. The

purchaser and the vendor shall agree on any special precautions necessary, with regards to conditions that can occur during operation, maintenance, transportation, erection, commissioning, and testing.

**NOTE** The suitability of a material for application at temperatures below the ductile-brittle transition temperature is affected by the selection of fabrication methods and welding procedures. Some published standards for design-allowable stresses for metallic materials do not differentiate between rimmed, semi-killed, fully killed hot-rolled, and normalized material, nor do they take into account whether materials were produced under fine- or course-grain practices. The vendor should, therefore, exercise caution in the selection of materials, fabrication methods, and welding procedures for parts intended for services below 100 °F (38 °C).

- **6.12.4.3** The purchaser shall specify whether ASME *BPVC*, Section VIII, Division 1 or EN 13445 (all parts) shall apply with regard to impact-testing requirements.

**6.12.4.4** The governing thickness used to determine impact-testing requirements shall be the greater of the following:

- a) nominal thickness of the largest butt-welded joint;
- b) largest nominal section for pressure containment, excluding:
  - 1) structural support sections, such as feet or lugs,
  - 2) sections with increased thickness required for rigidity to mitigate shaft deflection,
  - 3) structural sections required for attachment or inclusion of mechanical features such as jackets or seal chambers;
- c) one-fourth of the nominal flange thickness, including parting flange thickness for axially split casings (in recognition that the predominant flange stress is not a membrane stress).

**6.12.4.5** If ASME *BPVC*, Section VIII, Division 1 is specified (see 6.12.4.3), the following shall apply:

- a) all pressure-retaining steels applied at a specified minimum design metal temperature below -20 °F (-29 °C) shall have a Charpy V-notch impact test of the base metal and the weld joint unless they are exempt in accordance with ASME *BPVC*, Section VIII, Division 1, UHA-51;
- b) carbon steel and low-alloy steel pressure-retaining parts applied at a specified minimum design metal temperature between -20 °F (-29 °C) and 100 °F (38 °C) shall require impact testing as follows:
  - 1) impact testing is not required for parts with a governing thickness of 1 in. (25 mm) or less;
  - 2) impact testing exemptions for parts with a governing thickness greater than 1 in. (25 mm) shall be established in accordance with ASME *BPVC*, Section VIII, Division 1, UCS-66. Minimum design metal temperature without impact testing may be reduced as shown in Figure UCS-66.1. If the material is not exempt, Charpy V-notch impact test results shall meet the minimum impact energy requirements of ASME *BPVC*, Section VIII, Division 1, UG-84.

## 6.13 Nameplates and Rotation Arrows

**6.13.1** A nameplate shall be securely attached at a readily visible location on the equipment and on any other major piece of auxiliary equipment.

**6.13.2** The nameplate shall be stamped with the following information, in units consistent with the Purchase Order:

- a) purchaser's item number,
- b) vendor's size and model number,

- c) pump serial number,
- d) rated flow,
- e) rated head,
- f) casing hydrostatic test pressure,
- g) speed,
- h) manufacturer's bearing identification numbers (if applicable),
- i) MAWP,
- j) temperature basis for MAWP,
- k) purchaser's purchase order number,
- l) bare shaft pump weight.

**6.13.3** In addition to being stamped on the nameplate, the pump serial number shall be plainly and permanently marked on the pump casing.

**6.13.4** Rotation arrows shall be cast in or attached to each major item of rotating equipment at a readily visible location.

**6.13.5** Nameplates and rotation arrows (if attached) shall be of austenitic stainless steel or of nickel-copper alloy UNS N04400 [equivalent to Monel <sup>14</sup>]. Attachment pins shall be of the same material as the nameplate or rotation arrow. Welding is not permitted as an attachment method.

## 7 Accessories

### 7.1 Drivers

**7.1.1** The driver shall be sized to meet the maximum specified operating conditions, including bearing, mechanical seal, external gear, and coupling losses, as applicable, and shall be in accordance with the applicable specifications, as stated in the inquiry specification, data sheets, and order. The driver shall be suitable for satisfactory operation under the utility and site conditions specified.

**7.1.2** The driver shall be sized to accommodate specified process variations such as changes in pressure, temperature, or properties of the liquid handled, as well as specified special plant start-up conditions.

**7.1.3** Unless otherwise specified, for drive-train components that have a mass greater than 500 lb (225 kg), the equipment feet shall be provided with vertical jackscrews.

- **7.1.4** Unless otherwise specified, electric motor drives shall conform to guidelines of 7.1.4.1 through 7.1.4.3, or other standard as approved by the purchaser. The purchaser shall specify if IEC motors are required.

**7.1.4.1** Low-voltage induction motors shall be in accordance with IEEE 841 [up to 500 hp (370 kW)].

**7.1.4.2** General-purpose medium-voltage induction motors shall be in accordance with API 547 [250 hp (186 kW) and larger].

---

<sup>14</sup> Monel™ is an example of a suitable product available commercially. This information is given for the convenience of users of this standard and does not constitute an endorsement by API of this product.



**7.1.4.3** Special-purpose medium- and high-voltage induction motors shall be in accordance with API 541 [500 hp (373 kW) and larger].

NOTE API 541 and API 547 are applicable to either NEMA or IEC and ISO, as specified. IEEE 841 is available as NEMA only, as there is no equivalent IEC or ISO standard to IEEE 841 at this time. The purchaser and vendor agree on the requirements in this case.

**7.1.5** Motors shall have nameplate power ratings, excluding the service factor (if any), at least equal to the percentages of power at pump rated conditions given in Table 12. However, the power at rated conditions shall not exceed the motor nameplate rating. The smallest acceptable motor power rating to be supplied is 5 hp (4 kW). If it appears that this procedure leads to unnecessary oversizing of the motor, an alternative proposal shall be submitted for the purchaser's approval.

**Table 12—Power Ratings for Motor Drives**

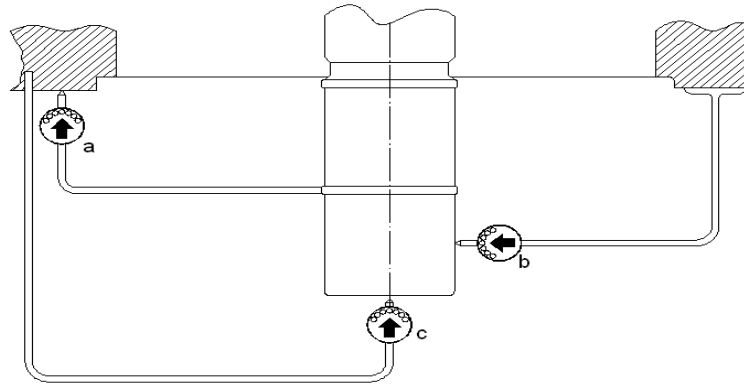
Motor Nameplate Rating		Percentage of Rated Pump Power
hp	kW	%
< 30	< 22	125
30 to 75	22 to 55	115
> 75	> 55	110

- **7.1.6** The purchaser shall specify the type of motor, its characteristics, and the accessories, including the following:
  - a) electrical characteristics;
  - b) starting conditions (including the expected voltage drop on starting);
  - c) type of enclosure;
  - d) SPL;
  - e) area classification, based on IEC 60079 or API 500;
  - f) type of insulation;
  - g) required service factor;
  - h) ambient temperature and elevation above sea level;
  - i) transmission losses;
  - j) temperature detectors, vibration sensors and heaters, if these are required;
  - k) vibration acceptance criteria;
  - l) applicability of IEC 60034-1, IEC 60034-2-1, API 541, API 547, or IEEE 841.

**7.1.7** Unless otherwise specified, the motor shall be capable of accelerating the pump to rated speed at 80 % voltage against a closed discharge valve.

NOTE Some pumps are equipped with bypasses, in which case alternative starting conditions can be used.

**7.1.8** Unless otherwise specified, motors for vertical pumps shall have solid shafts. Motors shall meet the shaft and base tolerances shown in Figure 36.



- |   |  |                             |
|---|--|-----------------------------|
| a | Shaft-to-driver mating face perpendicularity and surface flatness. | 0.002 in./ft (0.17 mm/m)    |
| b | Maximum shaft runout with rotor rotating freely.                   | 0.001 in. (25 $\mu$ m) TIR  |
| c | Maximum axial float.   | 0.005 in. (125 $\mu$ m) TIR |

All measurements shall be taken with the assembled driver in the vertical position.

**Figure 36—Vertical Pump Drivers—Tolerances Required for the Driver Shaft and Base**

**7.1.9** Bearings in the drive systems designed for radial or axial loads transmitted from the pump shall meet the following requirements.

- a) Rolling-element bearings shall be selected to give a basic rating life, in accordance with ISO 281, equivalent to at least 25,000 h with continuous operation at pump rated conditions.
- b) Rolling-element bearings shall be selected to give a basic rating life equivalent to at least 16,000 h when carrying the maximum loads (radial or axial or both) imposed with internal pump clearances at twice the design values and when operating at any point between minimum continuous stable flow and rated flow. Vertical motors of 1000 hp (750 kW) and larger that are equipped with spherical or taper roller bearings may have less than 16,000 h life at worst conditions to avoid skidding in normal operation. In such cases, the vendor shall state the shorter design life in the proposal.
- c) For vertical motors and right-angle gears, the thrust bearing shall be in the nondrive end and shall limit axial float to 0.005 (125  $\mu$ m).
- d) Single-row, deep-groove ball bearings shall have radial internal clearance in accordance with ISO 5753, Group 3 [larger than "N" (Normal) internal clearance]. Single- or double-row bearings shall not have filling slots.
- e) Thrust bearings shall be designed to carry the maximum thrust that the pump can develop while starting, stopping, or operating at any flowrate.
- f) Hydrodynamic thrust bearings shall be selected at no more than 50 % of the bearing manufacturer's rating at twice the pump internal clearances specified in 6.7.5.

**7.1.10** Unless otherwise specified, steam turbine drivers shall conform to API 611. Steam turbine drivers shall be sized to deliver continuously 110 % of the pump rated power at normal steam conditions.

**7.1.11** Unless otherwise specified, gears shall conform to API 677.

## 7.2 Couplings

**7.2.1** Unless otherwise specified, couplings between drivers and driven equipment shall be supplied and mounted by the vendor with unit responsibility.

**7.2.2** Unless otherwise specified, couplings shall be all-metal, spacer-type manufactured in accordance with AGMA 9000, Class 9. Additionally, couplings shall comply with the following:

- a) Flexible elements shall be non-lubricated metal type of corrosion-resistant material.
- b) Couplings shall be designed to positively retain the spacer if a flexible element ruptures.

**NOTE** The use of bolt heads or flexible element fasteners alone to retain the spacer if a flexible membrane ruptures might not provide adequate support because they are subject to wear if and when failure occurs.

- c) Coupling hubs shall be steel.
- d) The distance between the pump and driver shaft ends (distance between shaft ends, or DBSE) shall be greater than the seal cartridge length for all pumps other than OH type or at least 5 in. (125 mm) and shall permit removal of the coupling, bearing housing, bearings, seal, and rotor, as applicable, without disturbing the driver, driver coupling hub, pump coupling hub, or the suction and discharge piping. For BB and VS pump types, this dimension, DBSE, shall always be greater than the total seal length,  $l$ , listed in Table 7.

**NOTE** The DBSE dimension usually corresponds to the nominal coupling spacer length.

- e) Provision shall be made for the attachment of alignment equipment without the requirement to remove the spacer or dismantle the coupling in any way.

**NOTE** One way of achieving this is to provide at least 1 in. (25 mm) of bare shaft between the coupling hub and the bearing housing where alignment brackets can be located.

- f) Couplings operating at speeds in excess of 3800 r/min shall meet the requirements of API 671 for component balancing and assembly balance check.
- g) If specified, major coupling components (hubs, spacer/flex element, and weight-matched hardware) shall be balanced in accordance with ISO 21940-11, to the balance grade specified by the purchaser.

**7.2.3** Couplings and coupling to shaft junctures shall be rated for the maximum driver power, including the driver service factor.

- **7.2.4** If specified, couplings shall meet the requirements of API 671, ISO 14691, or ISO 10441.

**NOTE** Purchasers can specify API 671 in order to comply with API 686 requirements for coupling hub runout during equipment installation. Without this specification, standard coupling hubs cannot be expected to meet these special runout requirements.

**7.2.5** Information on shafts, keyway dimensions (if any), and shaft end movements due to end play and thermal effects shall be furnished to the vendor supplying the coupling.

**7.2.6** Flexible couplings shall be keyed to the shaft. Keys, keyways, and fits shall conform to AGMA 9002, Commercial Class. Shaft coupling keyways shall be cut to accommodate a rectangular cross section key. Sled-runner type keys and keyways shall not be provided. Keys shall be fabricated and fitted to minimize unbalance.

**7.2.7** For shaft diameters greater than 2.5 in. (60 mm) and if it is necessary to remove the coupling hub to service the mechanical seal, the hub shall be mounted with a taper fit. The coupling fit taper for keyed couplings shall be 1 in 16 (0.75 in./ft, 60 mm/m diametral). Other mounting methods and tapers shall be agreed upon by the purchaser and the vendor. Coupling hubs with cylindrical bores may be supplied with slip fits to the shaft and set screws that bear on the key.

NOTE Appropriate assembly and maintenance procedures should be used to assure that taper fit couplings have an interference fit. Slip fits on cylindrical bores allow adjustment of the coupling axial position in the field without application of heat.

**7.2.8** Coupling hubs designed for interference fits to the shaft shall be furnished with tapped puller holes at least 0.38 in. (10 mm) in diameter to facilitate removal.

- **7.2.9** If specified, couplings shall be fitted hydraulically.
- **7.2.10** If specified, couplings shall be fitted with a proprietary clamping device. Acceptable clamping devices may include tapered bushings, frictional locking assemblies, and shrink discs. The vendor responsible for the final machining of the hub bores shall select a suitable rating/size device to suit the coupling and the application.

NOTE Some devices are not inherently self-centering and can introduce eccentricity and unbalance into the coupling assembly. This effect is a factor when determining coupling potential unbalance.

**7.2.11** If the vendor is not required to mount the driver, the fully machined half-coupling shall be delivered to the driver manufacturer's plant or any other designated location, together with the necessary instructions for mounting the half-coupling on the driver shaft.

### 7.3 Guards

**7.3.1** Unless otherwise specified, guards between drivers and driven equipment and between the bearing housing and seal gland shall be supplied and mounted by the vendor with unit responsibility.

**7.3.2** Each coupling shall have a coupling guard that is removable without disturbing the coupled elements. Each coupling guard shall meet the following requirements:

- a) enclose the coupling and the shafts to prevent personnel from contacting moving parts during operation of the equipment train; allowable access dimensions shall comply with specified standards, such as ISO 14120, or ANSI B11.19;
  - b) be constructed with sufficient stiffness (rigidity) to withstand a 200 lbf (900 N) static point load in any direction without the guard contacting moving parts;
  - c) be fabricated from sheet (solid or perforated), plate, or expanded metal; any openings shall conform to ISO 14120, EN 953, or ANSI B11.19, but in no case shall exceed 0.375 in. (10 mm); guards of woven wire shall not be used;
  - d) be constructed of steel, brass, aluminum, nickel-copper alloy, or nonmetallic (polymer) materials, as suitable.
- **7.3.2.1** If specified, coupling guards shall be constructed of an agreed spark-resistant material (see 6.10.2.9, Note).
  - **7.3.2.2** If specified for coupling guards with potentially explosive atmospheres, an ignition hazard assessment (risk analysis) in accordance with EN 13463-1 shall be conducted and a suitable report provided.

**7.3.3** Exposed shaft areas including the area between pump bearing housing(s) and mechanical seal(s) shall have a shaft guard. The guard shall meet the following requirements:

- a) prevent personnel from contacting moving parts during operation of the pump; allowable opening dimensions shall comply with specified standards, such as EN 953 or ISO 14120;
- b) sufficiently vented to prevent the accumulation of seal emissions, liquid, or vapor;
- c) allow visual inspection of the seal without removal of guard;

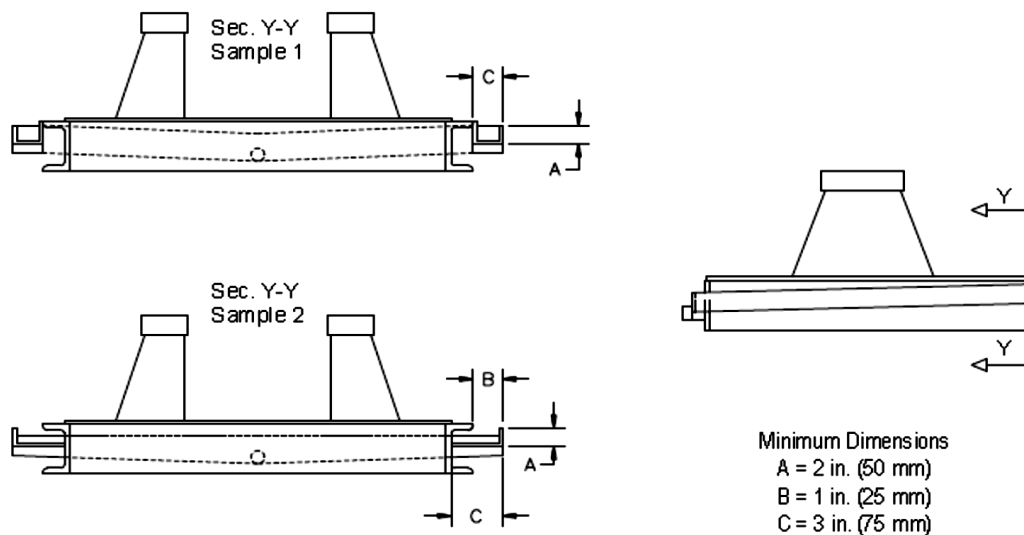
- d) constructed of steel, stainless steel, brass, or aluminum materials, as suitable;
- e) fabricated from sheet (solid or perforated), plate, expanded metal, or woven wire and securely fastened to the pump.

**7.3.3.1** For pipeline services, a solid shaft guard with a piping connection at the bottom to drain away any accumulated liquid and vapors is required. For this configuration, visual inspection of the seal is not required since the area is enclosed.

- **7.3.3.2** If specified, guards shall be designed to meet other purchaser requirements, such as providing access for volatile organic compound (VOC) emissions testing; protection from environmental elements (e.g. rain, sand); provide protection from directional spray in event of significant seal leakage; and special venting/draining arrangements. Any of these options or possible others shall be explicitly stated by the purchaser.
- **7.3.3.3** If specified, guards shall be constructed of an agreed spark-resistant material (see 6.10.2.9, Note).
- **7.3.3.4** If specified for guards with potentially explosive atmospheres, an “ignition hazard assessment” (risk analysis) in accordance with EN 13463-1 shall be conducted and a suitable report provided.

## 7.4 Baseplates

- **7.4.1** Single-piece baseplates designed for grouting shall be furnished for horizontal pumps. The purchaser shall specify the type and options as follows:
  - a) a flat deck plate with a sloped gutter drain that protrudes beyond the side rail flange and surrounds the entire baseplate (Figure 37);



**Figure 37—Flat Deck Plate with Sloping Gutter Drain**

- b) a sloped full deck plate, mounted between the side rails, which extends under the pump and drives train components (Figure 38);



**Figure 38—Sloped Full Deck Plate**

- c) a sloped partial deck plate, mounted between the side rails, which extends only under the pump and coupling (Figure 39);



**Figure 39—Sloped Partial Deck Plate**

- d) an open deck version of the above with no deck/top plate (this type may require increased structure to support the pump and nozzle loads);
- e) a nongrouted baseplate of one of the versions above where the baseplate and pedestal support assembly shall be sufficiently rigid to be mounted without a grout fill, but with uniform support along the side rails of the baseplate;
- f) a nongrouted baseplate as in Item e) with a gimbal mount, three-point mount, anti-vibration mount (AVM) spring mount, or other type of mount. Due to distance between supports, such baseplate types require a significantly stiffer and heavier structure to minimize deflections from nozzle loads, driver torque, and other loads.

**NOTE** The figures above (Figure 37, Figure 38, and Figure 39) are intended to clarify only the conceptual design of the deck plate and not the way it has to be supported by cross members.

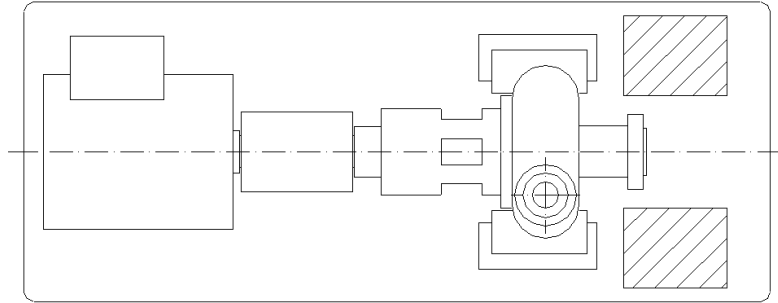
**7.4.2** The slope of either the gutter or deck plate shall be at least 1 in 120 toward the pump end and shall terminate in a tapped drain connection of at least NPS 2 (DN 50). The bottom of the connection shall be located sufficiently below the bottom of the rim or the deck to affect complete drainage.

**7.4.3** The baseplate shall extend under the pump and drive-train components so that any leakage is contained within the baseplate. To minimize accidental damage to components, all pipe joints and pipe flange faces, including pump suction and discharge flanges, shall be within the drain collection area. All other projections of the equipment supplied shall fall within the maximum perimeter of the baseplate. Oversized junction boxes may overhang the perimeter of the baseplate.

**7.4.4** If driver, pump size, auxiliary, and seal flush plan permit, baseplates may have standardized dimensions as given in Annex D (reference Table D.1 and Figure D.1). These baseplates are referred to as “Standard baseplates, numbers 2.5 to 12.”

**7.4.5** Auxiliary systems shall not block access to maintain the pump, motor, and coupling. If it is not possible to achieve this on a standard baseplate, a nonstandard dimensioned baseplate shall be used.

**7.4.6** Baseplates for OH2 pumps shall have nothing (auxiliaries or seal flush plan) mounted beside or above the coupling or bearing housing. If the seal flush plan and/or auxiliaries are specified to be mounted on the baseplate, the increased length standard baseplate shall be used and the auxiliaries and/or seal flush plan shall be mounted adjacent to the suction nozzle (see Figure 40).



**Figure 40—Location for Seal Flush Plan or Auxiliaries Mounted on the Baseplate**

**7.4.7** The height of the pump-shaft centerline above the baseplate shall be minimized. Sufficient clearance shall be provided between the casing drain connection and the baseplate for connecting piping by the purchaser. For threaded drains, clearance shall allow the use of a nipple and elbow of the same size as the connection. The use of a street (male-female) elbow is not allowed.

- **7.4.8** Mounting pads shall be provided for the pump and all drive-train components, such as motors and gears. The pads shall be larger than the foot of the mounted equipment, including extra width of shims under drive-train components, to allow levelling of the baseplate with a precision level, without removal of the equipment. The minimum exposed area on the mounting pads for leveling purposes shall be 2 in. (50 mm) on two sides of each foot. The pads shall be fully machined flat and parallel to each other. Corresponding surfaces shall be in the same plane within 0.002 in./ft (150  $\mu\text{m}/\text{m}$ ) of distance between the pads.

If specified, the flatness requirement shall be demonstrated in the pump-vendor's shop prior to mounting of the equipment and with the baseplate supported at the foundation bolt holes only. This demonstration is to be performed with the baseplate in the unclamped condition, after completion of machining.

**NOTE** Installed baseplate flatness can be affected by transportation, handling, and installation procedures beyond the vendor's scope. For information, see API 686.

- **7.4.9** Unless otherwise specified, pumps shall be mounted directly on mounting pads of the baseplate without shims. Shims shall not be used under the pump. Mounting pads for drive-train components shall be machined to allow for the installation of shims at least 0.12 in. (3 mm) thick under each component. If the vendor mounts the drive train components, a set of stainless steel shims (shim packs) at least 0.12 in. (3 mm) thick shall be furnished. Shim packs shall not be thicker than 0.5 in. (13 mm) nor contain more than 5 shims. All shim packs shall straddle the hold-down bolts and vertical jackscrews and extend at least  $\frac{1}{4}$  in. (5 mm) beyond the outer edges of the equipment feet. If the vendor does not mount the components, the pads shall not be drilled and shims shall not be provided.
- **7.4.10** If specified, in addition to shims under drive train components, pumps shall be mounted on solid stainless steel plates not less than 0.200 in. (5 mm) thick. Solid plates shall be machined parallel and flat on both sides and shall be the same length and width as the specific pump mounting feet.
- 7.4.11** All joints, including deck plate to structural members, shall be continuously seal-welded on both sides, or full penetration welded, to prevent crevice corrosion. Stitch welding anywhere, top or bottom, is unacceptable.

**7.4.12** The bottom of the baseplate between structural members shall be open if the baseplate is designed to be installed and grouted to a concrete foundation. Accessibility shall be provided for grouting under all load-carrying members. The bottom of the baseplate shall be in one plane to permit use of a single level foundation.

**7.4.13** Sufficient cross members shall be provided under pump and driver supports and the members shall be shaped to lock positively into the grout.

**7.4.14** All baseplates shall be provided with at least one grout hole having a clear area of at least 20 in.<sup>2</sup> (125 cm<sup>2</sup>) and with no dimension less than 3 in. (75 mm) in each bulkhead section. These holes shall be located to permit filling the entire cavity under the baseplate without creating air pockets. If practical, the holes shall be accessible for grouting with the pump and driver installed on the baseplate. Grout holes in the deck plate area shall have 0.5 in. (13 mm) raised lip edges. If the holes are located in an area where liquids can impinge on the exposed grout, metallic covers with a minimum thickness of 0.06 in. (1.5 mm, 16 gauge) shall be provided. Vent holes at least 0.5 in. (13 mm) in diameter shall be provided at the highest point in each bulkhead section of the baseplate. The vendor shall state on the pump arrangement drawing whether any equipment needs to be removed to accomplish grouting of the baseplate.

**7.4.15** The outside corners of the baseplate in contact with the grout shall have at least 2 in. (50 mm) radii in the plan view to minimize stress risers in the grout (see Figure D.1).

**7.4.16** Unless otherwise specified, the vendor shall commercially sand-blast, in accordance with ISO 8501 Grade Sa2 or SSPC SP 6, all grout contact surfaces of the baseplate and coat those surfaces with a primer compatible with epoxy grout. The manufacturer shall advise the purchaser the actual primer used.

NOTE Grouts other than epoxy can require alternative surface preparation. Full bond-strength of epoxy grout is not generally necessary (7.4.13).

**7.4.17** The baseplate shall have provisions for at least four lifting points. Lifting the baseplate, complete with all equipment mounted, shall not permanently distort or otherwise damage the baseplate or the machinery mounted on it.

**7.4.18** Lifting lugs attached to the baseplate or equipment shall be designed using a maximum allowable stress of one-third of the specified minimum yield strength of the material.

**7.4.18.1** Lugs or trunnions that are attached by welding shall have continuous welds. These welds shall be 100 % NDT tested in accordance with the applicable code (see Table 11).

- **7.4.18.2** Baseplates for installation in ambient temperatures below  $-20^{\circ}\text{F}$  ( $-29^{\circ}\text{C}$ ), unless otherwise specified, shall be constructed from standard structural steel materials and shapes since they are static, no impact, nonpressure boundary supports.

NOTE Low-temperature steels are not commonly available in structural shapes routinely used for baseplate construction.

- **7.4.18.3** The lifting lugs for low-temperature baseplates per 7.4.18.1 shall be constructed of low-temperature carbon steel or steel alloys rated for the low ambient temperature. If specified, Charpy impact testing of materials shall be required on low-temperature lifting lugs. Welds on the low-temperature lifting lugs shall be inspected as shown in Table 14. Lifting lugs that are bolted to the baseplate shall have bolting rated for low ambient temperature.

**7.4.19** Alignment positioning jackscrews shall be provided for drive-train components to facilitate horizontal transverse and longitudinal adjustments on the mounting pads. The jackscrews shall be suitably sized for the weight of the drive train component and shall be not less than size  $1/2$  to 13 UNC (M12). The jackscrews and any alignment fixtures shall not interfere with the installation or removal of shims under the drive component feet. Any fixtures or any brackets used to hold removable fixtures that are welded to the baseplate shall be welded prior to the machining the mounting pads to prevent distortion.



**7.4.20** Vertical levelling screws shall be provided adjacent to each anchor bolt to level the baseplate during baseplate installation. The jackscrews shall be adequate for the weight of the baseplate, pump, and drive-train components.

**7.4.21** The baseplate design shall have provisions for sufficient anchor bolting to withstand nozzle loads, driver torque, and any specified acceleration loads.

- **7.4.22** If specified, anchor bolts shall be provided by the pump vendor.

**7.4.23** To minimize misalignment of the pump and driver shafts due to nozzle loads, the pump and its baseplate shall be constructed with sufficient structural stiffness to limit displacement of the pump shaft at the drive end of the shaft or at the register fit of the coupling hub to the values shown in Table 13. These values are the acceptance criteria for the nozzle load test in 7.4.24. Grout shall not be used as a means of obtaining the required stiffness during this test.

**NOTE** It is recognized that grout can significantly increase the stiffness of the baseplate assembly. By neglecting this effect, the adequacy of the baseplate can easily be verified at the vendor's shop. It is also noted that thermal growth, piping fabrication errors, and alignment error all contribute to the actual shaft displacement values achieved in the field. Adherence to the nozzle load values in Table 5 limits the total displacement at the pump and drive shaft ends to approximately 0.010 in. (250  $\mu\text{m}$ ) (see Annex F).

- **7.4.24** If specified, the vendor shall test to demonstrate that the pump and its baseplate assembly, anchored at foundation bolt hole locations, are in compliance with 7.4.23. The pump casing shall be subjected to moments  $M_{Yc}$  and  $M_{Zc}$  applied to either the suction or discharge nozzle but not both simultaneously such that the corresponding shaft displacements can be measured and recorded.  $M_{Yc}$  and  $M_{Zc}$  shall not be applied simultaneously. The shaft displacement measurements shall be absolute (not relative to the baseplate). For record purposes, the vendor's test data shall include a schematic drawing of test set-up, the calculated moment loads ( $M_{Yc}$  and  $M_{Zc}$ ), and the applied moment loads and their corresponding displacements at the drive end of the pump shaft.

**Table 13—Stiffness Test Acceptance Criteria**

Baseplate Intended for Grouting		Baseplate Not Intended for Grouting	
Loading Condition	Pump Shaft Displacement in. ( $\mu\text{m}$ )	Pump Shaft Displacement in. ( $\mu\text{m}$ )	Direction
$M_{Yc}$	0.007 (175)	0.005 (125)	+Z
$M_{Zc}$	0.003 (75)	0.002 (50)	-Y

$M_{Yc}$  and  $M_{Zc}$  equal the sum of the allowable suction and discharge nozzle moments from Table 5.

$$M_{Yc} = (M_Y)_{\text{suction}} + (M_Y)_{\text{discharge}}$$

$$M_{Zc} = (M_Z)_{\text{suction}} + (M_Z)_{\text{discharge}}$$

## 7.5 Instrumentation

### 7.5.1 Gauges

Temperature indicators and pressure gauges shall be in accordance with API 614.

### 7.5.2 Vibration, Position, and Temperature Detectors

- **7.5.2.1** The purchaser shall specify whether accelerometers shall be provided. If provided, accelerometers shall be installed and tested in accordance with API 670.
- **7.5.2.2** If specified for equipment with hydrodynamic radial and thrust bearings, provision shall be made for mounting two radial-vibration probes in each bearing housing, two axial-position probes at the thrust end of

each machine, and a one-event-per-revolution probe in each machine. If supplied, these provisions shall be in accordance with API 670.

- **7.5.2.3** The purchaser shall specify whether detectors shall be provided. If provided, detectors and their mounting and calibration shall be installed and tested in accordance with API 670.

**7.5.2.4** If provisions or detectors are provided, surface areas to be observed by the radial shaft vibration probes (probe areas) shall meet the requirements of API 670.

- **7.5.2.5** If specified, hydrodynamic thrust and radial bearings shall be fitted with bearing metal temperature detectors. If pressure-lubricated hydrodynamic thrust and radial bearings are fitted with temperature detectors, the detectors and their mounting and calibration shall be supplied, installed, and tested in accordance with API 670.
- **7.5.2.6** If specified, monitors with cables connecting to vibration, axial-position, or temperature detectors shall be provided. If provided, monitors and cables shall be supplied in accordance with API 670.
- **7.5.2.7** If specified, monitors and cables shall be installed on the pump-driver train within the confines of the baseplate in accordance with API 670.

## 7.6 Piping and Appurtenances

### 7.6.1 General

**7.6.1.1** Piping shall be in accordance with API 614, API 682, and this standard. API 682 and this standard take precedence in case of conflicts with API 614.

**7.6.1.2** Auxiliary systems are defined as piping systems that are in the following services:

- auxiliary process liquids;
- steam;
- cooling water;
- lubricating oil (see 9.2.6).

Auxiliary system materials shall be in accordance with Table H.4.

NOTE Auxiliary connections are discussed in 6.4.3.

**7.6.1.3** The piping systems shall be fully assembled and installed. If this requirement causes difficulty in shipping and handling, alternative arrangements are acceptable with purchaser approval.

- **7.6.1.4** If specified, barrier/buffer fluid reservoirs shall be designed for mounting off the pump baseplate and shall be shipped separately. These reservoirs shall be fully assembled, except that the fluid-circulation tubing shall not be supplied.

**7.6.1.5** The vendor shall furnish and locate all piping systems, including mounted appurtenances, within the confines of the baseplate.

- **7.6.1.6** If specified, each piping system shall be manifolded to a single purchaser's inlet or outlet connection near the edge and within the confines of the baseplate.

NOTE The data sheet allows selection of this option for vent, cooling water, and drain connections.

- **7.6.1.7** The bolting requirements of 6.1.36 shall apply to the connection of auxiliary piping to the equipment. Flange fasteners on stainless steel piping systems for lubricating oil services shall be stainless steel or if specified, low-alloy steel (e.g. ASTM A193/A194M, Grade B7) with polytetrafluoroethylene (PTFE) coating or other coating method acceptable to purchaser. Cadmium plated bolting is not acceptable.

**7.6.1.8** Plugs shall comply with 6.4.3.5.

## **7.6.2 Auxiliary Process Liquid Piping**

**7.6.2.1** Auxiliary process-liquid piping includes vent lines, drain lines, balance lines, product flushing lines, and lines for injection of external fluid.

**7.6.2.2** Piping components shall have a pressure-temperature rating at least equal to MAWP of the pump casing but in no case less than the ASME flange rating of the discharge connection of the pump.

**7.6.2.3** Piping and components subject to the process liquid shall have a corrosion/erosion resistance equal to or better than that of the casing. Otherwise, all components shall be steel.

- **7.6.2.4** Orifice openings shall not be less than 0.12 in. (3 mm) in diameter. Orifice hole size shall be stamped on the orifice plate. The purchaser shall specify orifice tagging or labelling requirements.

**7.6.2.5** Drain valves and a drain manifold shall be supplied for pumps that require more than one drain connection. The drain manifold shall be inside the drain pan limits.

Unless otherwise specified, for pumps with one drain connection, the drain shall be closed with a blind flange and gasket if a drain valve is not provided. The vendor shall provide space on the baseplate for a purchaser-supplied drain valve inside the pump drain pan or drain rim.

**7.6.2.6** For pumps in pipeline services, vent and drain connections that are threaded shall be plugged. Plugs shall be compatible with process fluid.

**7.6.2.7** If heating or cooling is provided, each exchanger component shall be suitable for the process liquid and cooling water to which it is exposed.

- **7.6.2.8** Unless otherwise specified by the purchaser, flanges or counter-flanges on the first pipe nipples threaded into seal gland connections shall be lap-joint flanges with butt-weld attachments to the nipples. With purchaser approval, socket-welded unions may be used in place of lap-joint flanges at the first connection from the seal gland.

**NOTE** Threaded connections are allowed on gland connections (see 6.4.3.5). If the remainder of the piping arrangement is flanged construction, a lap-joint flange or union welded to the first pipe nipple threaded into each seal gland connection enables repeated assembly and disassembly of the threaded connection without overstressing the threads. Socket-welded unions supplied in stainless steel tend to leak after repeated assembly and disassembly.

**7.6.2.9** Threaded piping joints may be used only on seal glands, bearing housing instrumentation connections, and for pumps in pipeline services with maximum operating temperature not greater than 130 °F (55 °C).

**7.6.2.10** Transmitters and pressure gauges shall have block-and-bleed valves.

## **7.6.3 Cooling-water Piping**

**7.6.3.1** The arrangement of cooling-water piping shall conform to Figure B.2, Figure B.3, Figure B.4, Figure B.5, Figure B.6, and Figure B.7, as applicable.

**7.6.3.2** Individual coolers and cooler elements shall be piped in parallel such that cooling water does not cool multiple coolers in series.

**7.6.3.3** The cooling-water piping shall be designed for the conditions in 6.1.28.

## **7.7 Special Tools**

**7.7.1** If special tools and fixtures are required to disassemble, assemble, or maintain the unit, they shall be included in the quotation and furnished as part of the initial supply of the machine. For multiple-unit installations, the requirements for quantities of special tools and fixtures shall be agreed upon by the purchaser and the vendor. These or similar special tools shall be used during shop assembly and post-test disassembly of the equipment.

**7.7.2** If special tools are provided, they shall be packaged in separate, rugged metal boxes and marked "special tools for (tag/item number)." Each tool shall be stamped or tagged to indicate its intended use.

## **8 Inspection, Testing, and Preparation for Shipment**

### **8.1 General**

- **8.1.1** The purchaser and the vendor shall agree on the points covered in 8.1.1.1 through 8.1.1.4.

**8.1.1.1** If shop inspection and testing have been specified, the purchaser and the vendor shall coordinate hold points and inspector's visits.

**8.1.1.2** The expected dates of testing shall be communicated at least 30 days in advance and the actual dates confirmed as agreed. Unless otherwise agreed, the vendor shall give at least 5 working days advanced notification of a witnessed or observed inspection or test.

NOTE 1 For smaller pumps where set-up and test time is short, 5 day notice can require the removal of the pump from the test stand between preliminary and witness tests.

NOTE 2 All witnessed inspections and tests are hold points. For observed tests, the purchaser could be in the factory longer than for a witnessed test.

- **8.1.1.3** If specified, witnessed mechanical and performance tests shall require a written notification of a successful preliminary test. The vendor and purchaser shall agree whether or not to maintain the machine test set-up or whether the machine can be removed from the test stand between the preliminary and witnessed tests.

**8.1.1.4** Many purchasers prefer not to have preliminary tests prior to witnessed tests, in order to understand any difficulties encountered during testing. If this is the case, the purchaser shall make it clear to the vendor.

**8.1.2** The vendor shall notify subvendors of the purchaser's inspection and testing requirements.

**8.1.3** After advance notification to the vendor by the purchaser, the purchaser's representative shall have reasonable access to all vendor and subvendor plants where manufacturing, testing, or inspection of the equipment is in progress. The level of access shall be agreed upon.

**8.1.4** Equipment, materials, and utilities for the specified inspections and tests shall be provided by the vendor.

- **8.1.5** If specified, the purchaser's representative, the vendor's representative, or both shall indicate compliance in accordance with an inspector's checklist such as that provided in Annex E by initialing, dating, and submitting the completed checklist to the purchaser before shipment.

**8.1.6** The purchaser's representative shall have access to the vendor's quality program for review.

## 8.2 Inspection

### 8.2.1 General

- **8.2.1.1** The vendor shall keep the following data available for at least 20 years:
  - a) necessary or specified certification of materials, such as mill test reports;
  - b) test data and results to verify that the requirements of the specification have been met;
  - c) if specified, details of all repairs and records of all heat treatment performed as part of a repair procedure;
  - d) results of quality control tests and inspections;
  - e) as-built running clearances;
  - f) other data specified by the purchaser or required by applicable codes and regulations (see L.3.1 and L.3.2).

**8.2.1.2** Pressure-containing parts shall not be painted until the specified inspection and testing of the parts is complete.

- **8.2.1.3** In addition to the requirements of 6.12.1.6, the purchaser may specify the following:
  - a) parts that shall be subjected to surface and subsurface examinations;
  - b) type of examination required, such as magnetic particle (MT), liquid penetrant (PT), radiographic (RT), and ultrasonic (UT) examinations.

**8.2.1.4** All preliminary running tests and mechanical checks shall be completed by the vendor before the purchaser's final inspection.

### 8.2.2 Pressure Casing and Process Piping Materials Inspection

**8.2.2.1** Unless otherwise specified, pressure casing and process piping materials shall be inspected in accordance with the requirements of Table 14.

**NOTE** Although the pump is designed to meet specific pressure and temperature requirements and the casing is hydrostatically tested in accordance with the requirements of this standard, this alone does not guarantee that the material is of a suitable quality for the service. Casting quality can be affected by considerable variations in material processing. Material standards, such as ASTM, provide minimum requirements for the material itself, but castings can be subject to areas of shrinkage, gas porosity, hot tears, sand inclusions, improper weld repairs, etc. In addition, some materials are prone to grain boundary tears or cracks that can propagate under in-service stresses caused by temperature, pressure, vibration, and pipe strain.

**8.2.2.2** For double-casing pumps, the outer casing pressure/temperature shall be used to determine the inspection class of the outer casting (see 8.2.2.1). The inner casing shall be inspected to Class I (Table 14).

**8.2.2.3** The timing of the inspections required by Table 14 shall be as follows.

**8.2.2.3.1** VI/MT/PT shall be performed after final heat treatment in the proof (rough) machined condition. In the proof (rough) machined condition, an additional amount of material remains on areas where machining to critical dimensions and tolerances is required. The additional amount of material removed shall not exceed 0.040 in. (1 mm) material stock or 5 % of minimum allowable wall thickness, whichever is less.

**8.2.2.3.2** RT/UT of castings shall be performed after final heat treatment.

**8.2.2.3.3** RT of welds and UT of wrought material and welds shall be performed after final heat treatment. UT of wrought material shall be performed prior to any machining operations that can interfere with the UT examination.

**8.2.2.4** Where the configuration of a casting makes radiography impossible, radiographic examination may be replaced by ultrasonic testing.

**8.2.2.5** Unless otherwise specified, inspection methods and acceptance criteria shall be in accordance with those in Table 15 as required by the material specification. If additional RT, UT, MT, or PT examination of the welds or materials is specified by the purchaser, the methods and acceptance criteria shall also be in accordance with the standards shown in Table 15. Alternative standards may be proposed by the vendor or specified by the purchaser. The welding and material inspection data sheet in Annex N may be used for this purpose.

- **8.2.2.6** If specified, the purchaser may inspect for cleanliness of the equipment and all piping and appurtenances furnished by or through the vendor before assembly.

**Table 14—Pressure Casing and Process Piping Material Inspection Requirements**

Type of Component	Requirements by Inspection Class <sup>a g</sup>		
	I	II	III
—	Minimum	> 80 % MAWP and > 392 °F (200 °C)	< 0.5 SG or > 392 °F (200 °C) and < 0.7 SG, or > 500 °F (260 °C) Extremely hazardous services <sup>e</sup>
Casing <sup>b</sup> : cast	VI	VI, plus MT or PT of critical areas	VI, plus MT or PT of critical areas, plus RT or UT of critical areas
Casing <sup>b</sup> : wrought <sup>c f</sup>	VI	VI, plus MT or PT of critical areas	VI, plus MT or PT (critical areas), plus UT (critical areas)
Nozzle weld: casing	VI, plus 100 % MT or PT	VI, plus 100 % MT or PT	VI, plus 100 % MT or PT plus RT (100 %)
Auxiliary connection welds <sup>d</sup>	VI	VI, plus MT or PT	VI, plus MT or PT (100 %)
Internals	VI	VI	VI
Auxiliary process piping: socket welded	VI	VI, plus 100 % MT or PT	VI, plus 100 % MT or PT
Auxiliary process piping: butt welded	VI, plus 5 % RT	VI, plus 100 % MT or PT and 5 % RT	VI, plus 100 % MT or PT and 10 % RT

<sup>a</sup> Definition of abbreviations: MT, magnetic particle inspection; PT, liquid penetrant inspection; RT, radiographic inspection; UT, ultrasonic examination; VI, visual inspection.

<sup>b</sup> “Casing” includes all items of the pressure boundary of the finished pump casing (e.g. the casing itself and other parts, such as nozzles, flanges, etc. attached to the casing). “Critical areas” are inlet nozzle locations, outlet nozzle locations, and casing wall thickness changes. The manufacturer shall submit details of the critical areas proposed to receive MT/PT/RT/UT inspection for purchaser’s approval.

<sup>c</sup> “Wrought” materials include forgings, plate, and tubular products.

<sup>d</sup> Due to complex geometry and thickness variations, it is not practical to RT butt-welded auxiliary casing connections.

<sup>e</sup> Extremely hazardous services, as specified by the purchaser.

<sup>f</sup> Longitudinal welds of seam-welded pipe used to fabricate pressure casing walls shall be inspected by radiography, with 100 % coverage for all inspection classes. See 9.3.2.6.

<sup>g</sup> See 6.12.3.3 and 6.12.3.4 for further non-destructive testing requirement explanations.

- **8.2.2.7** If specified, the hardness of parts, welds and heat-affected zones shall be verified as being within the allowable values by testing. The method, extent, documentation, and witnessing of the testing shall be agreed upon by the purchaser and the vendor.
- **8.2.2.8** If specified, pressure boundary parts of alloy materials shall be subject to positive material identification (PMI) using recognized testing methods, instrumentation, and standards. The purchaser and vendor shall agree on the specific parts tested, procedures used, and acceptance criteria. Only techniques providing quantitative results shall be used. Mill test reports, material composition certificates, visual stamps, or markings shall not be considered substitutes for PMI testing.

NOTE PMI is not available to differentiate between grades of carbon steels.

**Table 15—Materials Inspection Standards**

Type of Inspection	Methods	Acceptance Criteria	
		For Fabrications	For Castings
Radiography (RT)	ASME <i>BPVC</i> , Section V, Articles 2 and 22	ASME <i>BPVC</i> , Section VIII, Division 1, UW-51 (for 100 % radiography) and UW-52 (for spot radiography)	ASME <i>BPVC</i> , Section VIII, Division 1, Appendix 7
Ultrasonic inspection (UT)	ASME <i>BPVC</i> , Section V, Articles 5 and 23	ASME <i>BPVC</i> , Section VIII, Division 1, Appendix 12	ASME <i>BPVC</i> , Section VIII, Division 1, Appendix 7
Liquid-penetrant inspection (PT)	ASME <i>BPVC</i> , Section V, Articles 6 and 24	ASME <i>BPVC</i> , Section VIII, Division 1, Appendix 8	ASME <i>BPVC</i> , Section VIII, Division 1, Appendix 7
Magnetic-particle inspection (MT)	ASME <i>BPVC</i> , Section V, Articles 7 and 25	ASME <i>BPVC</i> , Section VIII, Division 1, Appendix 6	ASME <i>BPVC</i> , Section VIII, Division 1, Appendix 7
Visual inspection (VI) (all surfaces)	ASME <i>BPVC</i> , Section V, Article 9	In accordance with the material specification and the manufacturer's documented procedures	MSS SP-55

## 8.3 Testing

### 8.3.1 General

- **8.3.1.1** If specified, at least 6 weeks before the first scheduled running test, the vendor shall submit to the purchaser for review and comment, detailed procedures for all running tests and all specified optional tests (8.3.4). The test procedure shall include the actual measurement uncertainty of all data used in the calculation of flow, head, and power as well as all acceptance criteria.

**8.3.1.2** Performance and NPSH tests shall be conducted using the methods and uncertainty requirements of HI 14.6 (ISO 9906), Grade 1. Performance tolerances shall be in accordance with Table 16. Evaluation of results shall be in accordance with 8.3.3.4.3.

**8.3.1.3** Mechanical seals shall not be used during the hydrostatic test but shall be used during all running or performance tests.

### 8.3.2 Hydrostatic Test

**8.3.2.1** The intent of a hydrostatic test of a centrifugal pump casing is to ensure that the design and construction of the pump pressure-containing components and joints are leak-free from ambient conditions to the maximum operation conditions.

**8.3.2.2** All pressure casing components shall be hydrostatically tested as assemblies. The test shall be conducted with liquid at a minimum of 1.5 times the MAWP.

**8.3.2.3** The test set-up and/or apparatus shall not provide stiffening that improves the integrity of any joint.

**8.3.2.4** Gaskets used during hydrostatic testing of an assembled pressure casing, less seal glands, shall be of the same design as those supplied with the pump and shall be installed without sealant.

**8.3.2.5** The test liquid shall be at a temperature higher than the nil-ductility transition temperature of the material being tested.

NOTE Refer to ASTM E1003 for additional information.

**8.3.2.6** If the part tested will operate at a temperature at which the strength of a material is below the strength of that material at the testing temperature, the hydrostatic test pressure shall be multiplied by a factor obtained by dividing the allowable working stress for the material at the testing temperature by that at the rated operating temperature. The stress values used shall be determined in accordance with 6.3.4. For piping, the stress shall conform to ISO 15649 or ASME B31.3, as specified. The pressure thus obtained shall then be the minimum pressure at which the hydrostatic test shall be performed. The actual hydrostatic test pressures shall be recorded. Applicability of this requirement to the material being tested shall be verified before hydrostatic test, as the properties of many grades of steel do not change appreciably at temperatures up to 400 °F (204 °C).

**8.3.2.7** The hydrostatic test liquid shall include a wetting agent to reduce surface tension if one or more of the following conditions exist;

- a) the liquid pumped has a relative density (specific gravity) of less than 0.7 at the pumping temperature;
- b) the pumping temperature is higher than 500 °F (260 °C);
- c) the casing is cast from a new or altered pattern;
- d) the materials are known to have poor castability.

**8.3.2.8** The chloride content of liquids used to test austenitic stainless steel materials shall not exceed 100 ppm (100 mg/kg). To prevent deposition of chlorides as a result of evaporative drying, all residual liquid shall be removed from the tested parts at the conclusion of the test.

NOTE Chloride content is limited in order to prevent stress-corrosion cracking.

**8.3.2.9** Hydrostatic testing is permitted without the seal-gland plate or removable seal chamber installed. The mechanical seal shall not be included in the hydrostatic test of the pump case. Gland plates and removable seal chambers shall be tested as specified in API 682. Seal chambers that are integral with the pump are not considered removable.

**8.3.2.10** Austenitic, duplex, and super duplex stainless steel pressure casing components may be hydrostatically tested in the proof (rough) machined condition (see 8.2.2.3).

Any areas that are machined after hydrostatic testing shall be identified on the hydrostatic test report.

NOTE Because of the residual stresses resulting from final liquid quenching and relatively low proportional limits inherent in these materials, small amounts of permanent deformation can occur at critical dimensions during hydrostatic testing. By allowing a small amount of material to remain at these critical areas during hydrostatic testing, the necessity to add material by welding to restore close-tolerance dimensions after hydrostatic test is avoided.

**8.3.2.11** Tests shall be maintained for a sufficient period of time to permit complete examination of parts under pressure. The hydrostatic test shall be considered satisfactory if neither leaks nor seepage through the pressure-containing parts and joints occur within 30 minutes. Large, heavy pressure-containing parts can require a longer testing period as agreed upon by the purchaser and the vendor. Seepage past internal



closures required for testing of segmented cases and operation of a test pump to maintain pressure is acceptable.

**8.3.2.12** Double-casing pumps, horizontal multistage pumps, integral-gear pumps (as described in 6.3.8), and other special-design pumps as approved by the purchaser may be segmentally tested. Seepage past internal closures required for testing of segmented cases and operation of a test pump to maintain pressure is acceptable. If testing of sections of a casing at different pressures is approved, each section shall be tested independently at the appropriate pressure. Alternatively, a combined test may be conducted with the appropriate pressure simultaneously in each section.

**8.3.2.13** Piping systems fabricated by welding shall be hydrostatically tested. Testing and stress levels shall be in accordance with ASME B31.3.

**NOTE** It is not necessary to hydrostatically test piping systems assembled with tubing or threaded connections after assembly.

**8.3.2.14** Unless otherwise specified, single-stage overhung-pump casing components with a radial joint (mean gasket diameter) 24 in. (610 mm) in diameter or less may be hydrostatically tested as components or subassemblies provided that joint design integrity has been proven by qualification testing for the specific size of pump and pressure rating in question.

**8.3.2.15** Cooling passages and components, including jackets for bearings, seal chambers, oil coolers, and seal coolers, shall be tested at a minimum gauge pressure of 150 psi (10.5 bar).

**8.3.2.16** Steam, cooling-water, and lubricating-oil piping, if fabricated by welding, shall be tested at 1.5 times maximum operating gauge pressure or 150 psi (10.5 bar), whichever is greater.

### **8.3.3 Performance Test**

**8.3.3.1** Unless otherwise specified, each pump shall be given a performance test in accordance with HI 14.6 or ISO 9906 except with the additional requirements of this standard.

**8.3.3.2** The following requirements shall be met while the pump is operating on the test stand and before the performance test is performed.

**8.3.3.2.1** The contract seals and bearings shall be used in the pump for the performance test.

**8.3.3.2.2** The seal (or seals) shall not have a leakage rate during any phase of the pump performance test that is in excess of that specified in API 682, or as otherwise agreed by the vendor and purchaser. Any unacceptable leakage during the pump performance test requires a disassembly and repair to the seal. If the seal is disassembled or removed, the seal shall be retested with an air test of the pump using the criteria defined in 8.3.3.8.4. When the pump is on the test stand and water is used as the test liquid, liquid seals suitable for testing on water shall exhibit no visible signs of leakage.

**NOTE** API 682 can be reviewed to confirm that a zero-visible-leakage criterion is appropriate for the seals being tested. Notably, pressurized dual seals with high barrier-fluid pressures greater than 600 psi (40 bar) are prone to visible signs of leakage.

**8.3.3.2.3** All lubricating-oil pressures, viscosities, and temperatures shall be within the range of operating values recommended in the vendor's operating instructions for the specified unit being tested.

**8.3.3.2.4** Bearings specified as normally lubricated from a pure oil-mist system shall be pre-lubricated prior to performance testing using a suitable hydrocarbon oil.

**8.3.3.2.5** All joints and connections shall be checked for tightness and any leaks shall be corrected.

**8.3.3.2.6** All warning, protective, and control devices used during the test shall be checked and adjusted as required.

**8.3.3.2.7** Performance tests shall be performed using water at a temperature not exceeding 130 °F (55 °C).

- **8.3.3.3** The following options for testing require approval of the purchaser.

**8.3.3.3.1** If approved by the purchaser, substitute seals may be used during the performance test, if needed, to prevent damage to the contract seals or if the contract seals are not compatible with the test liquid. See API 682.

**8.3.3.3.2** If specified, seal leakage during test shall require the assembled pump and seal to be rerun to demonstrate satisfactory seal performance.

**8.3.3.3.3** Performance tests may be conducted at temperatures exceeding 130 °F (55 °C) if approved by the purchaser.

**8.3.3.4** Unless otherwise specified, the performance test shall be conducted as follows.

**8.3.3.4.1** The vendor shall take test data, including head, flowrate, power, and vibration at a sufficient number of points, to characterize the performance curve. Each test point within the allowable operating range of the pump shall be no more than 35 % (of rated flow) removed, by its flowrate, from any other test point within the allowable operating range. Figure M.4 provides a graph demonstrating the points. These points will normally include the following and may have a tolerance of  $\pm 3$  % flow:

- 1) shutoff (no vibration data required),
- 2) flow point at minimum continuous stable flow (beginning of allowable operating region),
- 3) flow point at approximately halfway between minimum continuous stable flow and minimum preferred operating flow,
- 4) flow point at minimum preferred operating flow,
- 5) flow point at approximately halfway between minimum preferred operating flow and rated flow,
- 6) flow point between 95 % and 99 % of rated flow,
- 7) flow point between rated flow and 105 % of rated flow,
- 8) flow point at the end of preferred operating region,
- 9) flow point at the end of allowable operating region if different from the end of the preferred operating region.

For units with BEP less than 50 gpm (11 m<sup>3</sup>/h), Point 3) and Point 5) are not required.

**NOTE** Based on curve and relative position of rated point to BEP, all of the above points need not be recorded for a given test. The intent of the 35 % maximum-separation criteria above is to fully define the shape of the curve.

**8.3.3.4.2** Some higher energy, integrally geared, or multistage pumps exhibit a high rate of increase of the temperature at shutoff that makes it not feasible and/or not safe to test them at shut off. The temperature increase is strictly related to the power density. The power density, PD, can be approximated as:

$$PD = \frac{P_{\text{rated}}}{D_{\text{imp}}^2 \times D_{\text{nozzle}}}$$

where

$P_{\text{rated}}$  is the rated power per stage in hp (or MW) with water;

$D_{\text{imp}}$  is the rated impeller diameter in in. (or m);

$D_{\text{nozzle}}$  is the nominal outlet flange diameter in in. (or m). For double-suction, single-stage pumps,  $D_{\text{nozzle}}$  is the inlet flange diameter.

A typical critical value of PD, beyond which it is suggested that the pump not be operated at shutoff during performance test is 0.286 hp/in.<sup>3</sup> (13 MW/m<sup>3</sup>).

**8.3.3.4.3** The test data shall be fit to a spline or an appropriate polynomial (typically, not less than a third order) for head and for power using a least squares method. The resulting polynomial equation shall be stated on the head and power calculated. These values shall be corrected for speed, viscosity, and density (specific gravity). The corrected values of head and power shall be within the tolerance bands allowed in Table 16.

**Table 16—Performance Tolerances**<sup>d e</sup>

Condition	Rated Point %	Shutoff %
Rated differential head:		
0 to 250 ft (0 to 75 m)	± 3	± 10 <sup>a</sup>
> 250 ft to 1000 ft (75 m to 300 m)	± 3	± 8 <sup>a</sup>
> 1000 ft (> 300 m)	± 3	± 5 <sup>a</sup>
Rated power	4 <sup>b</sup>	—
Efficiency	c	
Rated NPSH	0	—
<p><sup>a</sup> If a rising head flow curve is specified (see 6.1.13), the negative tolerance specified here shall be allowed only if the test curve still shows a rising characteristic.</p> <p><sup>b</sup> With test results corrected to rated conditions (see 8.3.3.4.3) for flow, speed, density (specific gravity), and viscosity, it is necessary that the power not exceed 104 % of the rated value, from all causes (cumulative tolerances are not acceptable).</p> <p><sup>c</sup> The uncertainty of test efficiency by the test code specified is ± 2.5 %; therefore, efficiency is not included in the pump's rated performance. In those applications where efficiency is of prime importance to the purchaser, a specific value and related tolerance shall be negotiated at the time of the order (see 8.3.3.5).</p> <p><sup>d</sup> The tolerances at the rated point in this table are identical to those for a Class 1B test in HI 14.6 (ISO 9906). They are repeated here because HI does not list tolerances to shutoff. API 610 does not utilize the HI tolerance on efficiency. API 610 uses the head and the power tolerances at a specified rated flow.</p> <p><sup>e</sup> Attention is called to Section 14.6.3.4.1 of HI 14.6. The tolerances in this table may not be appropriate for pumps with rated powers less than 13 hp (10 kW).</p>		

**8.3.3.4.4** Unless otherwise agreed, the test speed shall be within 3 % of the rated speed shown on the pump data sheet (see example in Annex N). Test results shall be corrected to rated speed.

**8.3.3.4.5** The vendor shall maintain a complete, detailed log of all final tests and shall prepare the required number of copies, certified for correctness. Data shall include test curves and a summary of test performance data compared to guarantee points (see L.2.4, L.3.2.2, and example in Annex M).

- **8.3.3.4.6** If specified, in addition to formal submittal of final data in accordance with L.3.2.2, curves and test data (corrected for speed, specific gravity, and viscosity) shall be submitted within 24 h after completion of performance testing for purchaser's engineering review and acceptance prior to shipment.
- **8.3.3.5** For higher-power pumps (> 1350 hp) (> 1 MW), performance tolerances other than those in Table 16 can be appropriate. If specified, pump efficiency at rated flow shall be quoted to the tolerance given by the purchaser and shall be included in the pump's rated performance. If a tolerance is specified for rated efficiency, an additional test point as close to rated flow as practical shall be taken. The rated efficiency and tolerance shall be consistent with the test code being used, with particular attention to the uncertainty of efficiency determined by test to that code.

**8.3.3.6** During the performance test, the following requirements shall be met.

**8.3.3.6.1** Vibration values shall be recorded at the test points specified in 6.9.4.2 and in accordance with the requirements of 6.9.4.2. Vibration values shall not exceed those given in 6.9.4.6.

**8.3.3.6.2** For ring and splash-oil systems, oil sump temperatures shall be recorded at the beginning and the end of the test. For pure-oil mist systems, bearing housing temperatures shall be recorded at the beginning and the end of the test. For pressurized systems, bearing metal temperatures shall be recorded at the beginning and the end of the test. The duration of the test shall be indicated on the test report.

**8.3.3.6.3** Pumps shall operate within bearing temperature limits as defined in 6.10.2.7 and shall not display signs of unusual operation, such as noise caused by cavitation.

**8.3.3.6.4** If operated at rated speed, pumps shall perform within the tolerances given in Table 16.

**8.3.3.6.5** The equipment shall operate without visible oil leaks.

- **8.3.3.7** If specified, the performance test shall be conducted with test stand NPSHA controlled to no more than 110 % of the NPSHA specified by the purchaser.

NOTE It is the purpose of this test to evaluate pump performance with the specified NPSHA at pump suction.

**8.3.3.8** The following requirements shall be met after the performance test is completed.

**8.3.3.8.1** If it is necessary to dismantle a pump after the performance test for the sole purpose of machining impellers to meet the tolerances for differential head, no retest is required unless the reduction in diameter exceeds 5 % of the original diameter. The diameter of the impeller at the time of shop test, as well as the final diameter of the impeller, shall be recorded on a certified shop test curve that shows the operating characteristics after the diameter of the impeller has been reduced.

- **8.3.3.8.2** If specified, disassembly of multistage pumps for any head adjustment (including less than 5 % diameter change) after test shall be cause for retest.

**8.3.3.8.3** If it is necessary to dismantle a pump for any other correction, such as hydraulic performance, NPSH, or mechanical operation, the initial test shall not be acceptable, and the final performance test shall be run after the correction is made.

**8.3.3.8.4** If it is necessary to disturb the mechanical seal assembly following the performance test, or if the test seal faces are replaced with the job seal faces, the final seal assembly shall be air-tested as follows:

- a) pressurize each sealing section independently with clean air to a test gauge pressure of 25 psi (172 kPa, 1.72 bar);
  - b) isolate the test set-up from the pressurizing source and maintain the pressure for a minimum of 5 min, or 5 min per 1 ft<sup>3</sup> (30 l) of test volume, whichever is greater;
  - c) the maximum allowable pressure drop during the test shall be 2 psi (14 kPa, 0.14 bar).
- **8.3.3.9** Unless otherwise specified, pumps shall not be disassembled after final performance testing. The pump, including the seal chamber, shall be drained to the extent practical, filled with a water-displacing inhibitor within 4 h of testing and re drained. On some pump types, such as BB3 and BB5, if all the water cannot be eliminated using this process, the pumps shall be disassembled as much as necessary to ensure that all water is removed from internal passageways and balance lines, prior to the inhibitor application, to prevent corrosion and possible freezing damage.

**NOTE** Disassembly of the pump after final performance testing impacts the mechanical integrity of the unit as proven on test. Inspection of hydrodynamic bearings can be readily accomplished and is minimally invasive. Inspection of rolling-element bearings is limited to removal of outboard bearing end covers, where available. Removal of inboard end covers requires considerably more extensive disassembly for all pump types and essentially complete disassembly for OH and VS pump types. Inspection of the pump internals disturbs the casing joint on all pump types, the mechanical seals on BB and VS pumps, and the drive end bearing on BB2 and BB5 pumps.

## 8.3.4 Optional Tests

### 8.3.4.1 General

- If specified, the shop tests described in 8.3.4.2 through 8.3.4.7 shall be performed. Test details and required data (such as vibration and temperature data) shall be agreed upon by the purchaser and the vendor prior to conducting the tests.

### 8.3.4.2 Mechanical Run Test

- **8.3.4.2.1** If specified, the pump shall be run on the test stand at the rated flow and the bearing oil temperatures measured and recorded. The test shall continue until oil temperature measurements stabilize; that is, when temperature rise relative to ambient temperature is not more than 2 °F (1 °C) over a 10 minute period.
- **8.3.4.2.2** If specified, the pump shall be mechanically run at the rated flow for 4 h.

### 8.3.4.3 NPSH Required Test

- **8.3.4.3.1** If specified, the pump shall be given an NPSH required test in accordance with HI 14.6 or ISO 9906 except with the additional requirements of this standard.

**8.3.4.3.2** NPSH required tests shall determine NPSH<sub>3</sub> values at each of the test points 2, 5, 6, 7 and 8 (as identified in 8.3.3.4.1) based on 3 % head drop in single-stage pumps or 3 % first-stage head drop in pumps with two or more stages. The first-stage head of pumps with two or more stages shall be measured using a separate connection to the first-stage discharge, if possible, or alternatively, testing of the first stage only shall be conducted. Only with purchaser approval, the first-stage head may be determined by dividing total head by the number of stages.

**8.3.4.3.3** Unless otherwise specified or agreed, NPSH required tests shall be conducted for each test point by maintaining constant flow and measuring head vs NPSHA data as the NPSHA to the pump is reduced progressively until the drop in head is more than 3 % of the first head value (NPSH Type II test per HI 14.6). The test shall not proceed beyond a 20 % head breakdown (20 % of first-stage head for multistage pumps).

**8.3.4.3.4** For each test point of the NPSH required test, the first head value shall be measured with a starting NPSHA value equal to at least twice the NPSH<sub>3</sub> value shown on the proposal curve at the corresponding flow,

or if greater, with a starting NPSHA value equal to the NPSHA provided to the pump during the performance test at the corresponding flow.

NOTE If the performance test requirement of 8.3.3.7 is specified, it is possible that the head has already been affected by insufficient NPSHA, so starting at a higher NPSHA is desirable.

**8.3.4.3.5** For each test point of the NPSH required test, the second head value measured after the NPSHA to the pump is reduced by at least 3 ft (1 m) shall differ from the first head value by no more than the combined permissible uncertainty of the differential head measurement devices used to conduct the test. If second head value differs from the first by more than this uncertainty, the starting NPSHA to the pump shall be increased and the measurements for head vs NPSHA data shall be repeated, until two consecutive head measurements achieve this tolerance.

**8.3.4.3.6** Sets of head vs NPSHA data, one set for each test point of the NPSH required test, shall be recorded and plotted as separate head vs NPSHA curves. The NPSH3 values achieved at each test point shall be marked on these curves respectively. In addition, the NPSH required test results shall be recorded by producing an NPSH3 vs flow curve in accordance with HI 14.6 or ISO 9906.

**8.3.4.3.7** NPSH3 at the rated point shall not exceed the quoted value (see Table 16). Dismantling to correct NPSH3 performance requires retesting of the performance and NPSH required tests.

#### **8.3.4.4 Complete Unit Test**

- **8.3.4.4.1** If specified, the pump and driver train, complete with all auxiliaries that make up the unit, shall be tested together. If specified, torsional vibration measurements shall be made to verify the vendor's analysis. The complete-unit test shall be performed in place of or in addition to separate tests of individual components specified by the purchaser.

**8.3.4.4.2** The acceptable vibration limits of each component of the train shall be as per its applicable standards and specifications, except for reciprocating engines (in this case, limits shall be mutually agreed upon by purchaser, pump vendor, and engine subvendor).

- **8.3.4.5 Sound Level Test**

If specified, sound level tests shall be performed as agreed between the purchaser and the vendor.

NOTE ISO 3740, ISO 3744, and ISO 3746 can be consulted for guidance.

- **8.3.4.6 Auxiliary Equipment Test**

If specified, auxiliary equipment, such as oil systems, gears, and control systems, shall be tested in the vendor's shop. Details of the auxiliary equipment test(s) shall be developed jointly by the purchaser and the vendor.

- **8.3.4.7 Bearing-housing Resonance Test**

If a resonance test is specified, the bearing housing(s) shall be excited by impact or other suitable means with the pump un piped, and the modes of natural frequency determined by FFT spectrum measurements and the requirements of 8.3.4.7.1 through 8.3.4.7.4 shall be followed.

**8.3.4.7.1** Data shall be recorded and stored.

**8.3.4.7.2** A separation margin shall exist between determined modes of natural frequency and the following excitation frequencies:

- a) multiples of running speed, expressed in revolutions per minute equal to 1.0, 2.0, and 3.0 times;
- b) multiples of vane passing frequency equal to 1.0 and 2.0 times.

**8.3.4.7.3** Test acceptance criteria shall be agreed upon between the purchaser and the vendor. In case identified bearing housing resonance conditions cannot be detuned, acceptability of the dynamic behavior of the bearing housing(s) and its attachment shall be proven by means of bearing housing vibration measurements during regular performance test. Conditions where bearing housing vibration levels exceed of the maximum allowable values stated in 6.9.4.6 shall then be corrected by means of reducing vane pass excitation levels.

- **8.3.4.7.4** In case of an ASD application, the purchaser shall specify the applicable continuous operating speed range.

**NOTE** Regarding ASD applications, the above mentioned criteria are applicable to fixed speed operations. Due to potentially large operating speed ranges, it is often not possible to satisfy all of the applicable frequency separation margin requirements. Acceptability of such conditions can be proven by means of vibration measurements taken during a variable speed performance test (if applicable). In case acceptability cannot be proven, purchaser and vendor can agree on further measures aimed at reducing vane-pass excitation levels. In the field, ASDs can be programmed to avoid certain small operating speed ranges from continuous operation. It is also important to note that, due to the reduced energy in the pump, resonance conditions at lower operating speeds are not nearly as critical as resonances at higher speeds.

- **8.3.4.8 Spare Parts Test**

If specified, spare parts such as rotors, couplings, gears, diaphragms, bearings, and seals shall be tested. The vendor shall ensure that the spare parts are available for test at the same time as the original equipment and that all of the necessary components to test them are supplied. The test procedure shall be agreed between purchaser and vendor.

## **8.4 Preparation for Shipment**

- **8.4.1** If specified, a physical alignment between the pump shaft and the driver shaft shall be performed prior to shipment and reported to the purchaser.

**8.4.1.1** The alignment report shall document the angular and offset alignment requirements with allowances for thermal growth for the particular equipment.

**8.4.1.2** The alignment report shall record the actual angular and offset alignment results achieved, the measured DBSE, and the smallest measured radial clearance between each hold-down bolt and its bolt hole in the equipment.

**8.4.1.3** The minimum radial clearances between hold-down bolts and bolt holes shall be no less than 0.03 in. (0.8 mm) after acceptable alignment is achieved.

- **8.4.1.4** If specified, the alignment between the pump shaft and the driver shaft shall be witnessed by the purchaser.

- **8.4.2** Unless otherwise specified, equipment shall be prepared for domestic shipment. Domestic shipment preparation shall make the equipment suitable for outdoor storage for a period of at least 6 months with no disassembly required before operation except possibly inspection of bearings and seals. Preparation for longer storage or export shipment is more rigorous and, if specified, shall be provided by the vendor following agreed procedures.

**8.4.3** The equipment shall be prepared for shipment after all testing and inspection has been completed and the equipment has been released by the purchaser. The preparation shall include that specified in 8.4.3.1 through 8.4.3.9.

**8.4.3.1** Rotors shall be blocked if necessary. Blocked rotors shall be identified by means of corrosion-resistant tags attached with stainless steel wire.

**8.4.3.2** Internal surfaces of bearing housings and carbon-steel oil-systems components shall be coated with an oil-soluble rust preventive that is compatible with the lubricating oil.

**8.4.3.3** Bearing assemblies shall be fully protected from the entry of moisture and dirt. If vapor-phase inhibitor crystals in bags are installed in large cavities, the bags shall be attached in an accessible area for ease of removal. If applicable, bags shall be installed in wire cages attached to flanged covers and bag locations shall be indicated by corrosion-resistant tags attached with stainless steel wire.

**8.4.3.4** Exterior surfaces, except for machined surfaces, shall be given at least one coat of the manufacturer's standard paint. The paint shall not contain lead or chromates. It is not necessary to paint stainless steel parts. The undersides of baseplates shall be prepared for grout in accordance with 7.4.16.

**8.4.3.5** Exterior machined surfaces, except for corrosion-resistant material, shall be coated with a rust preventive.

**8.4.3.6** Flanged openings shall be provided with metal closures at least 0.19 in. (5 mm) thick, with elastomeric gaskets and at least four full-diameter bolts. For studed openings, all nuts required for the intended service shall be used to secure closures.

**8.4.3.7** Threaded openings shall be provided with steel caps or steel plugs in accordance with 6.4.3.7.

**8.4.3.8** Openings that have been beveled for welding shall be provided with closures designed to prevent entrance of foreign materials and damage to the bevel.

**8.4.3.9** Exposed shafts and shaft couplings shall be wrapped with waterproof, moldable waxed cloth or volatile-corrosion inhibitor paper. The seams shall be sealed with oil-proof adhesive tape.

**8.4.4** Auxiliary piping connections furnished on the purchased equipment shall be impression-stamped or permanently tagged to agree with the vendor's connection table or general arrangement drawing. Service and connection designations shall be indicated. Symbols for all pump connections, including plugged connections, shall be in accordance with Annex B.

**8.4.5** Lifting points and lifting lugs shall be clearly identified.

**8.4.6** The equipment shall be identified with item and serial numbers. Material shipped separately shall be identified with securely affixed, corrosion-resistant metal tags indicating the item and serial number of the equipment for which it is intended. Crated equipment shall be shipped with duplicate packing lists, one inside and one on the outside of the shipping container.

**8.4.7** One copy of the manufacturer's standard installation manual shall be packed and shipped with the equipment.

**8.4.8** The vendor shall provide the purchaser with API-686-compliant instructions for the preservation of the integrity of the storage preparation at the job site and before start-up.

**8.4.9** Horizontal pumps, and all furnished drivers and auxiliaries, shall be shipped fully assembled on their baseplates, except as noted below. Coupling spacers with bolts and other items, such as minimum flow orifices that are not part of the assembled pumping unit, shall be separately boxed, tagged, and securely attached to the baseplate.

**8.4.10** Drivers for vertical pumps and horizontal drivers with a mass over 450 lb (200 kg) may be removed after shop mounting and alignment and shipped separately but alongside pump. Vertical pumps with suction cans shall be shipped with the suction cans (barrels) removed.

**8.4.11** If it is necessary to ship other major components separately, prior purchaser approval is required.

**8.4.12** Metal filter elements and screens shall be cleaned and reinstalled prior to shipment. Nonmetallic filter elements shall be shipped and installed in an unused condition.

**8.4.13** Suitable rust preventatives shall be oil-soluble and compatible with all pumped liquids.



**8.4.14** Equipment or materials that contain or are coated with chemical substances shall be prominently tagged at openings to indicate the nature of contents and precautions for shipping, storage, and handling.

NOTE Some examples include oils, corrosion inhibitors, antifreeze solutions, desiccants, hydrocarbon substances, and unused paint.

**8.4.14.1** Substances that are supplied with the shipment shall have a safety data sheet (SDS).

**8.4.14.2** If a substance is exempt from regulation, a statement to that effect shall be included.

**8.4.14.3** At least 2 weeks before shipment, SDSs shall be forwarded to the receiving facility, to allow planning for handling of any regulated substances.

**8.4.14.4** SDSs in protective envelopes shall be affixed to the outside of the shipping package.

## 9 Specific Pump Types

### 9.1 Single-stage Overhung Pumps

#### 9.1.1 Horizontal (Type OH2) Pumps

**9.1.1.1** Rear pump bearing housing supports are not permitted.

**9.1.1.2** The distance between the pump and driver shaft ends (DBSE) shall permit removal of the coupling spacer and back pull-out assembly without disturbing the driver, coupling hubs, or casing.

- **9.1.1.3** If specified, the shaft flexibility index (SFI) shall be calculated by the vendor in accordance with Equation (K.1) and reported.

NOTE The design and operation requirements for overhung pump rotors are detailed in several areas of this standard. Annex K lists these requirements and establishes a standardized means of calculating a SFI that can be used to evaluate these latter parameters and to establish a baseline for the comparison of shaft flexibility.

#### 9.1.2 Vertical In-line (Type OH3) Pumps

**9.1.2.1** A flat contact surface shall be provided on the bottom of the casing to make the pump stable if freestanding on a pad or foundation. The ratio of the unit center of gravity height to the contact surface width shall be no greater than 3:1. This stability shall be achieved through the design of the casing or by a permanent external stand.

**9.1.2.2** Pumps shall be designed so that they can either float with the suction and discharge piping or be bolted to a pad or foundation.

NOTE Flange loading on the pump can increase if the purchaser elects to bolt down the unit. This should be addressed in the piping design.

**9.1.2.3** A minimum NPS  $\frac{1}{2}$  (DN 15) tapped drain connection shall be provided so that no liquid collects on the cover or driver support.

**9.1.2.4** The pump and seal chamber shall be continuously vented with a high point connection in either the seal chamber or seal flush piping. Purchaser approval is necessary for systems that require manual venting.

NOTE If venting to the atmosphere is not acceptable, the vent is usually connected to the process piping at an elevation above the seal chamber.

**9.1.2.5** The distance between the pump and driver shaft ends (DBSE) shall permit removal of the coupling spacer and back pull-out assembly without disturbing the driver, coupling hubs, or casing.

- **9.1.2.6** If specified, a device that allows direct rigging or lifting of the back pull-out assembly from outside the motor support with the driver in place shall be provided.

**9.1.2.7** With the purchaser's approval, bearing housings may be arranged for grease lubrication (6.11.4). The stabilized bearing-housing temperature shall not exceed a 70 °F (39 K) rise above ambient temperature.

**9.1.2.8** Drivers shall be aligned in the vendor's shop prior to shipment.

**9.1.2.9** Driver supports of vertical in-line pumps that utilize thrust bearings in the driver shall be steel.

### **9.1.3 Integral Gear-driven (Type OH6) Pumps**

**9.1.3.1** The impeller shall be keyed or splined to the gearbox output shaft.

**9.1.3.2** Integral-gear pumps may require removal of the driver to allow disassembly of the rotor and the seal assembly.

- **9.1.3.3** The need for a rotor lateral analysis shall be determined as described in 9.2.4.1.

NOTE Lateral critical speeds can be of concern with type OH6 pumps. Normally, pumps of this type are thoroughly investigated during development, and typical rotor dynamics are available and applicable.

**9.1.3.4** Single-piece hydrodynamic radial bearings may be used.

- **9.1.3.5** Temperature and pressure gauges mounted directly on the gearbox shall be in accordance with API 614 except that the diameter of the gauges shall be 2.0 in. (50 mm). If specified, separable threaded solid-bar thermowells shall be supplied for temperature gauges.

**9.1.3.6** Inducers, impellers, and similar major rotating components shall be dynamically balanced to ISO 21940-11, Grade G2.5, or to a residual unbalance of 0.01 oz in. (7 g mm), whichever is greater. If possible, the mass of the arbor used for balancing shall not exceed, the mass of the component being balanced. The resulting vibration measured during the performance test shall not exceed the levels in Table 8.

## **9.2 Between-bearings Pumps (Types BB1, BB2, BB3, and BB5)**

### **9.2.1 Pressure Casings**

**9.2.1.1** Axially split casings may have a composition sheet gasket or a metal-to-metal joint; the vendor's bid shall state which is being offered.

**9.2.1.2** Pumps for service temperatures below 300 °F (150 °C) may be foot-mounted.

**9.2.1.3** For pumps with axially split casings, lifting lugs or tapped holes for eyebolts shall be provided for lifting only the top half of the casing and shall be so tagged. Methods for lifting the assembled machine shall be specified by the vendor [see Annex L].

- **9.2.1.4** If specified, proposed connection designs shall be submitted to the purchaser for approval before fabrication. The drawing shall show weld designs, size, materials, and pre-weld and postweld heat treatments.
- **9.2.1.5** If specified, an acoustic analysis of the crossover passages of BB3 and BB5 pumps shall be performed and reported to the purchaser. The acoustic report shall document the lengths of crossover passages within the pump casing, the sound velocity in the pumped fluid at operating temperature and pressure, the calculated half-wave frequencies corresponding to crossover passage lengths and sound velocity, and the vane-pass frequencies produced by the impeller-casing design of the pump. Acoustical resonance responses shall be evaluated whenever one or more half-wave frequency in any crossover passage is sympathetic to a vane-pass frequency of the pump.

## 9.2.2 Rotor

**9.2.2.1** Impellers of multistage pumps shall be individually located along the shaft by a shoulder or captive split ring in the direction of normal hydraulic thrust.

**9.2.2.2** Rotors with clearance-fit impellers shall have mechanical means to limit impeller movement in the direction opposite to normal hydraulic thrust to 0.030 in. (0.75 mm) or less.

- **9.2.2.3** If specified, rotors with shrink-fit impellers shall have mechanical means to limit movement in the direction opposite to normal hydraulic thrust to 0.030 in. (0.75 mm) or less.

**9.2.2.4** The runout of shafts and assembled rotors measured with the shaft or rotor supported on V-blocks or bench rollers adjacent to its bearings shall be within the limits given in Table 17.

## 9.2.3 Running Clearances

**9.2.3.1** Renewable casing bushings and interstage sleeves or the equivalent shall be provided at all interstage points.

**9.2.3.2** Running clearances associated with components used to balance axial thrust or to serve as product-lubricated internal bearings may be the manufacturer's standard, provided these clearances are stated as exceptions to this standard (see 6.7.5) in the proposal and are approved by the purchaser. If the manufacturer's standard clearances are based on material combinations exhibiting superior wear characteristics, supporting data shall be included in the proposal.

**Table 17—Shaft and Rotor Runout Requirements**

Flexibility Factor $F_f^{a,b}$ in. <sup>2</sup> (mm <sup>2</sup> )	Allowable Shaft Runout TIR in. (μm)	Component Fit on Shaft	Allowable Rotor Radial Runout TIR <sup>c</sup> in. (μm)
$> 3 \times 10^6 (1.9 \times 10^9)$	0.0015 (40)	Clearance	0.0035 (90)
		Interference	0.0025 (60)
$\leq 3 \times 10^6 (1.9 \times 10^9)$	0.0010 (25)	Clearance	0.0030 (75)
		Interference	0.0020 (50)
<p><sup>a</sup> <math>F_f = L^4/D^2</math> where <math>L</math> is the bearing span; <math>D</math> is the shaft diameter (largest) at impeller.</p> <p><sup>b</sup> The shaft flexibility factor, <math>F_f</math>, is directly related to the static deflection of a simply supported shaft and is, therefore, a good indicator of the runout attainable during manufacture and the quality of balance that can be achieved and maintained.</p> <p><sup>c</sup> Runout of impeller hubs, balancing drum, and sleeves.</p>			

## 9.2.4 Dynamics

### 9.2.4.1 Lateral Analysis

**9.2.4.1.1** Unless otherwise specified, the need for a lateral analysis of a pump's rotor shall be determined using the decision logic set out in Table 18.

**Table 18—Decision Logic for Rotor Lateral Analysis**

Step	Action
1	Design pump
2	Does a similar pump (3.1.54) or an identical pump (3.1.18) exist? If "yes," go to step 5. If "no," go to step 3.
3	Is rotor classically stiff (3.1.8)? If "yes," go to step 5. If "no," go to step 4.
4	Analysis required
5	Analysis not recommended

- **9.2.4.1.2** If a lateral analysis is required by the process in 9.2.4.1.1, or if specified by the purchaser, it shall be performed in accordance with Annex I and its results assessed in accordance with I.1.2 through I.1.5.

NOTE Depending on pump design, the first or second wet lateral critical speed of multistage and high-speed pumps can coincide with the operating speed, particularly as internal clearances increase with wear. A lateral analysis can predict whether this coincidence is likely and whether the resulting vibration will be acceptable.

#### 9.2.4.2 Rotor Balancing

**9.2.4.2.1** Rotors of the categories listed below shall be two-plane dynamically balanced at low speed to the balance grade in Table 19:

- multistage pumps (three or more stages);
- one- and two-stage pumps whose maximum continuous speed is greater than 3800 r/min.

**9.2.4.2.2** The sequence of rotor assembly and balance correction shall follow ISO 11342. For balancing, the rotor does not include the pump half-coupling hub or the rotary units of the mechanical seals.

NOTE 1 Table 19 shows ISO 21940-11, Grade G2.5 for all interference fit rotors to speeds of 3800 r/min. This is based on two factors:

- at 3800 r/min, the upper limit of balance Grade G2.5 produces a force due to unbalance of 10 % of rotor weight, which means that unbalance does not have any material effect on the rotor's operating shape;
- for rotors whose flexibility is high (see Table 17), it is not practical to achieve and maintain the rotor straightness necessary for balance Grade G1.

NOTE 2 The mass eccentricity associated with balance Grade G1 is very small, e.g. 0.00010 in. (2.5  $\mu$ m) maximum for operation at 3800 r/min. This has two consequences:

- it is not practical to balance the components to better than G2.5 (see 6.9.4.1) because the arbor effectively changes when the component is mounted;
- the balance quality might not be verifiable if the rotor is disturbed from its position on the balancing stand or disassembled and reassembled. It is normally possible, however, to perform a residual unbalance check to verify the accuracy of the balancing stand.

**Table 19—Rotor Balance Requirements**

Component Fit on Shaft	Maximum Continuous Speed r/min	Flexibility Factor $L^4/D^2$ in. <sup>2</sup> (mm <sup>2</sup> )	Rotor Balance Procedure(s) <sup>b</sup>	Rotor Balance Grade
Clearance	≤ 3800 <sup>a</sup>	No limit	C	<sup>c</sup>
Interference	≤ 3800	No limit	C + B or D	G2.5 / (16W/N) <sup>d</sup>
	> 3800	≤ 3 × 10 <sup>6</sup> (1.9 × 10 <sup>9</sup> )	C + B or D	G0.67 / (4W/N) <sup>d e</sup>
NOTE See Table 17 for shaft and rotor runout requirements.				
<sup>a</sup> To allow for 5 % speed increase. <sup>b</sup> See ISO 11342. <sup>c</sup> Balance correction during assembly is not feasible because clearance fit does not maintain corrected balance. <sup>d</sup> Approximately equal to the midpoint of the corresponding ISO balance quality grade. <sup>e</sup> If rotors of higher flexibility are used at speeds above 3800 r/min, achieving and maintaining this balance level requires special attention to design, manufacture, and maintenance.				

**9.2.4.2.3** For rotor balancing, any vacant single keyways shall be filled completely with crowned half keys.

**9.2.4.2.4** If a rotor is balanced as an assembly, a residual unbalance test shall be performed. The check shall be carried out after final balancing of the rotor, following the procedure given in Annex J. The mass and location of all half keys used during final balancing of the assembled rotor shall be recorded on the residual unbalance worksheet as part of the “rotor sketch” or separately sketched and recorded on an attachment to the Annex J worksheet.

## 9.2.5 Bearings and Bearing Housings

**9.2.5.1** If supplied, hydrodynamic radial bearings shall be in accordance with 9.2.5.1.1 through 9.2.5.1.4.

**9.2.5.1.1** Bearings shall be split for ease of assembly, precision-bored, and of the sleeve or pad type, with steel-backed, babbitted replaceable liners, pads, or shells. The bearings shall be equipped with anti-rotation pins and shall be positively secured in the axial direction.

**9.2.5.1.2** The liners, pads, or shells shall be in axially split housings and shall be replaceable without having to dismantle any portion of the casing or remove the coupling hub.

**9.2.5.1.3** Bearings shall be designed to prevent installation backwards or upside down or both.

**9.2.5.1.4** If the shaft contains more than 1.0 % chromium and the journal surface speed is above 65 ft/s (20 m/s), the shaft's journal shall be hard-chromium-plated, hard-coated, or sleeved with carbon steel.

NOTE The purpose of this construction is to avoid damage to the bearing from wire-wooling.

**9.2.5.2** Hydrodynamic thrust bearings shall be in accordance with 9.2.5.2.1 through 9.2.5.2.5 below.

**9.2.5.2.1** Thrust bearings shall be of the steel-backed, babbitted multiple-segment type, designed for equal thrust capacity in both directions and arranged for continuous, pressurized lubrication to each side. Both sides shall be of the tilting-pad type, incorporating a self-levelling feature that assures that each pad carries an equal share of the thrust load with minor variation in pad thickness.

**9.2.5.2.2** Thrust collars shall be replaceable and shall be mounted to the shaft with an interference fit to prevent fretting and positively locked to prevent axial movement.

**9.2.5.2.3** Both faces of thrust collars shall have a surface roughness of not more than 16  $\mu\text{in.}$  (0.4  $\mu\text{m}$ )  $R_a$ , and, after mounting, the axial TIR of either face shall not exceed 0.0005 in. (13  $\mu\text{m}$ ).

**9.2.5.2.4** Thrust bearings shall be sized for the maximum, continuous, applied load (see 6.10.1.2). At this load, and the corresponding rotational speed, the following parameters shall be met:

- a) minimum oil-film thickness of 0.0003 in. (8  $\mu\text{m}$ );
- b) maximum unit pressure (load divided by area) of 500 psi (35 bar, 3500 kPa);
- c) maximum calculated babbitt surface temperature of 265 °F (130 °C).

**NOTE** The limits given above correspond to a design factor of two or more, based on the bearing's ultimate capacity. The calculated Babbitt surface temperature is a design value and is not representative of actual babbitt temperatures under these conditions. Bearings sized to meet the above criteria have the following allowable metal temperatures on shop test and in the field (see 6.10.2.7):

— shop test on water and normal operation in the field limit: 200 °F (93 °C);

— field alarm or trip level: 240 °F (115 °C).

**9.2.5.2.5** Thrust bearings shall be arranged to allow axial positioning of each rotor relative to the casing and the setting of the bearing's clearance or preload.

- **9.2.5.2.6** If specified, thrust-bearing design and sizing shall be reviewed and approved by the purchaser.

**9.2.5.3** If the inlet oil temperature exceeds 120 °F (50 °C), special consideration shall be given to bearing design, oil flow, and allowable temperature rise. Oil outlets from thrust bearings shall be as recommended by the bearing manufacturer for the collar speed and lubrication method involved. Oil connections on bearing housings shall be in accordance with 7.6.

**9.2.5.4** Axially split bearing housings shall have a metal-to-metal split joint whose halves are located by means of cylindrical dowels.

## **9.2.6 Lubrication**

- **9.2.6.1** If specified, or if recommended by the vendor and approved by the purchaser, a pressure-lubrication system shall be furnished to supply oil at a suitable pressure to the pump bearings, the driver, and any other driven equipment, including gears.

**9.2.6.2** External pressure-lubrication systems shall comply with the requirements of API 614. The minimum acceptable system for equipment furnished to this standard shall meet design codes Class II-P0-R1-H0-BP0-C1F2-C0-PV1-TV1-BB0 for systems mounted on pump baseplates and Class II-P0-R1-H0-BP1-C1F2-C0-PV1-TV1-BB0 for systems mounted as stand-alone consoles, as defined in API 614, Fifth Edition. For such a lubrication system, data sheets shall be supplied.

**9.2.6.3** If oil is supplied from a common system to two or more machines (such as a pump, a gear, and a motor), the oil's characteristics shall be suitable for all equipment supplied. The vendor having unit responsibility shall obtain approval from the purchaser and the other equipment vendors for the oil selection.

**NOTE** The typical lubricants employed in a common oil system are mineral (hydrocarbon) oils that correspond to ISO Grades 32 through 68, as specified in ISO 3448.

- **9.2.6.4** If specified, the pressure-lubrication system shall conform to the requirements of API 614. For such a lubrication system, data sheets shall be supplied.

## 9.2.7 Testing

**9.2.7.1** For pressure-lubricated bearings, test stand oil and oil system components downstream of the filters shall meet the cleanliness requirements specified in API 614.

**9.2.7.2** All purchased vibration probes, transducers, and oscillator-demodulators shall be in use during the test. If vibration probes are not furnished by the vendor or if the purchased probes are not compatible with shop readout facilities, shop probes and readouts that meet the accuracy requirements of API 670 shall be used. The vibration measured with this instrumentation shall be the basis for acceptance or rejection of the pump.

**9.2.7.3** With the purchaser's approval, single-stage, double-suction pumps may be assembled for testing by driving from the opposite end of the pump when compared to the general arrangement for the contract pump and driver. No retest is required after final assembly. If such an arrangement is required, it shall be stated in the proposal.

NOTE This is sometimes required to accommodate test stand piping constraints.

- **9.2.7.4** If specified, hydrodynamic bearings shall be removed, inspected by the purchaser or their representative, and reassembled after the performance test is completed. No retest is required after final assembly.

## 9.2.8 Preparation for Shipment

**9.2.8.1** If a spare rotor or element is purchased, it shall be prepared for unheated indoor storage for 3 years. Storage preparation shall include treatment with a rust preventive and enclosure in a vapor-barrier envelope with slow-release vapor-phase inhibitor. The rotor or element shall be boxed for the type of shipment specified. A rotor shall have a resilient material [but not lead, tetrafluoroethylene (TFE), or PTFE], at least 0.12 in. (3 mm) thick, between the rotor and its support cradle; support shall not be at the rotor's journals. An element shall have its rotor secured to prevent movement within the stator.

- **9.2.8.2** If specified, spare rotors and cartridge-type elements shall be prepared for vertical storage. A rotor shall be supported from its coupling end with a fixture designed to support 1.5 times the rotor's mass without damaging the shaft. A cartridge-type element shall be supported from the casing cover (with the rotor hanging from its thrust bearing).
- **9.2.8.3** If specified, a shipping and storage container designed to store the rotor or cartridge vertically shall be provided.
- **9.2.8.4** If specified, the shipping and storage container shall be designed to allow inert-gas inhibition during storage.

## 9.3 Vertically Suspended Pumps (Types VS1 Through VS7)

### 9.3.1 General

**9.3.1.1** Specified discharge pressure shall be at the purchaser discharge connection. Hydraulic performance shall be corrected for column static and friction head losses. Bowl or pump casing performance curves shall be furnished with the correction indicated.

**9.3.1.2** It is not necessary that bearing housings for vertically suspended pumps be arranged so that bearings can be replaced without disturbing pump drives or mountings.

**9.3.1.3** A minimum of four alignment-positioning screws shall be provided for each driver to facilitate horizontal adjustment for shaft alignment.

**9.3.1.4** Driver supports of vertically suspended pumps that utilize thrust bearings in the driver shall be steel.

### 9.3.2 Pressure Casings

9.3.2.1 Jackscrews and casing alignment dowels are not required for rabbeted bowl assemblies.

9.3.2.2 Pumps shall be provided with vent connections for suction barrels and seal chambers.

9.3.2.3 Assemblies designed for O-ring seals only do not require flanges and bolting designed to seat a spiral-wound gasket (see 6.3.13).

9.3.2.4 Suction barrels or cans shall be designed with either elliptical (of either ellipsoidal or torispherical shapes) or flat plate bottom heads of adequate wall thickness for MAWP within tensile stress limits (see 6.3.4). All welds of suction barrels shall be full-penetration welds (see 6.12.3.3).

- 9.3.2.5 If specified, suction barrels or cans shall be designed with only elliptical bottom heads of either ellipsoidal or torispherical shapes. This option facilitates weld inspections by radiography (see 8.2.2.4).

9.3.2.6 Longitudinal welds of seam-welded pipe used to fabricate pressure casing walls of pump heads and suction barrels shall be inspected by radiography, with 100 % coverage in accordance with 8.2.2.5, prior to component fabrication.

- 9.3.2.7 If specified, pressure casing walls of pump heads and suction barrels or cans shall be fabricated of seamless pipe in accordance with ASTM A106, ASTM A53, ISO 3183, or API 5L material specifications.

9.3.2.8 For VS pumps with bowl OD of 8 in. (200 mm) or smaller, 0.31 in. (8 mm) fasteners are acceptable.

9.3.2.9 For VS1, VS2, and VS3 type pumps designed to be installed in pressure vessels or tanks, the component that constitutes the pressure casing is the discharge head.

9.3.2.10 For VS6 and VS7 type pumps, the components that constitute the pressure casing are the discharge head and the suction can.

### 9.3.3 Rotors

9.3.3.1 All pump shafts shall be machined or ground and finished throughout their entire length. The TIR shall not exceed 0.0005 in./ft (40  $\mu\text{m}/\text{m}$ ) of length. TIR runout shall be inspected at lengths of 4 ft (1.2 m) or less.

9.3.3.2 The pump shaft shall be in one piece unless otherwise approved by the purchaser (because of total shaft length or shipping restrictions).

### 9.3.4 Wear Parts and Running Clearances

9.3.4.1 Renewable casing bushings shall be provided at all interstage and other bushing locations.

9.3.4.2 The running clearances specified in 6.7.5 do not apply to the clearances of bushings. The clearances used shall be stated in the proposal and approved by the purchaser.

9.3.4.3 Pumps with semi-open impellers in an erosive service shall have a replaceable casing liner.

- 9.3.5 Dynamics

If specified, the vendor shall furnish a dynamic analysis of the complete pump (which includes belowground components) and driver structure on its foundation or support structure to confirm acceptability of the design. The purchaser and the vendor shall agree on the extent, method, and acceptance criteria for this analysis.

NOTE 1 Vertically suspended pumps are generally flexible structures with running speeds located between natural frequencies. As such, they are susceptible to resonant vibration if their separation margins are not verified during design. Typically, the deflection of the foundation represents less than 5 % of the total deflection of the structural elements. A



portion of the foundation or support structure can be included in the dynamic analysis; however, if foundation data are not available when the analysis is being conducted, an agreed-upon vertical stiffness value can be used as a minimum. Generally, an acceptance criteria of 20 % above and 15 % below running speed margin of separation is maintained between all the natural frequencies of the complete pump and driver structure and the rotational speed.

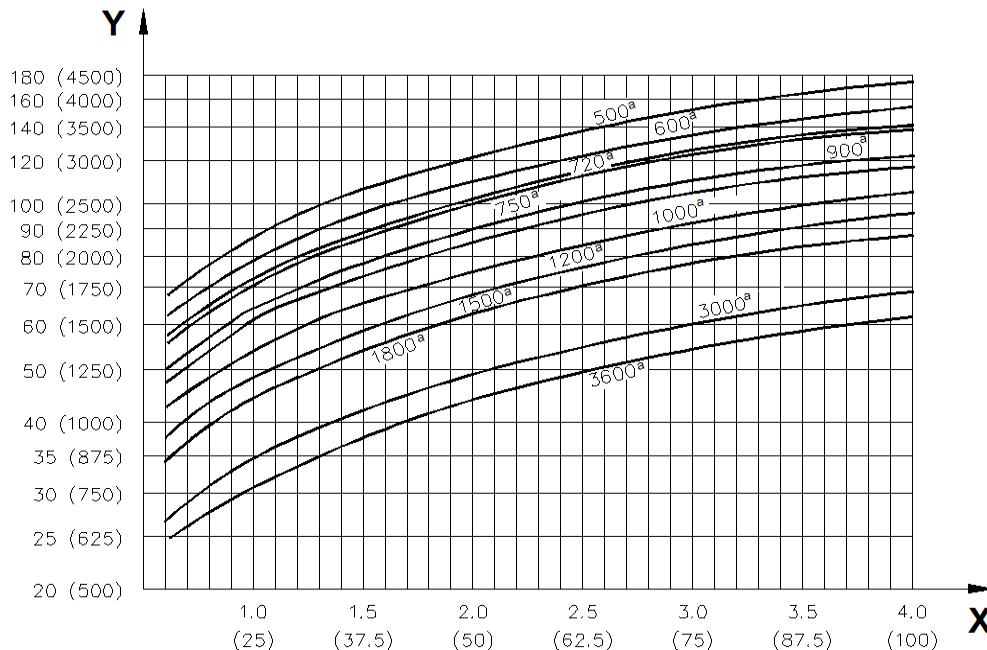
NOTE 2 Models are usually detailed enough to address not only aboveground motor/discharge head assemblies but belowground components as well with appropriate internal and external fluid added mass effects. Column bending modes up to the third bending mode that are potentially excited by 1.0 times rotational speed are normally considered.

NOTE 3 Detailed guidelines for the application and methodology of structural dynamic analyses to vertically suspended pumps are available from HI 9.6.8. API 684 can also be referenced for further guidance.

NOTE 4 If natural frequencies cannot be shifted to meet separation margins, then a forced response analysis can be conducted to assess vibration levels and determine the suitability of operating on or near a structural natural frequency. Levels of damping and excitation forces will then be agreed upon by both the vendor and the purchaser.

### 9.3.6 Bushings and Bearings

**9.3.6.1** Bushings shall be suitably corrosion-resistant and abrasion-resistant for the specified product and temperature. The maximum spacing between shaft bushings shall be in accordance with Figure 41 in order to maintain the first critical speed above the maximum allowable continuous speed.



#### Key

X shaft diameter, expressed in inches (millimeters)

Y maximum bushing spacing, expressed in inches (millimeters)

<sup>a</sup> Curves for various rotational speeds, expressed in revolutions per minute.

**Figure 41—Maximum Spacing Between Shaft Guide Bushings**

**9.3.6.2** Thrust bearings that are integral with the driver shall meet the requirements of 7.1.9. Thrust bearings and housings integral with the pump shall meet the applicable requirements of 6.10. To allow axial rotor adjustment and oil lubrication, the integral pump thrust bearing shall be mounted with an interference fit on a slide-fit, key-driven sleeve.

**9.3.6.3** Except for sump pumps of type VS4, the first-stage impeller shall be located between bushings.

NOTE Although between-bushing first-stage impellers can result in superior rotor support, certain applications, such as for sumps, require superior suction performance and can benefit from an overhung first-stage impeller arrangement.

### 9.3.7 Lubrication

Bushings in vertical pumps are normally lubricated by the liquid pumped. Alternative methods of lubrication shall be proposed if the pumped liquid is not suitable.

### 9.3.8 Accessories

#### 9.3.8.1 Drivers

**9.3.8.1.1** Pumps and motor assemblies that can be damaged by reverse rotation shall be provided with a nonreverse ratchet or another purchaser-approved device to prevent reverse rotation.

**9.3.8.1.2** Unless otherwise specified, motors for vertical pumps shall have solid shafts. If the pump thrust bearings are in the motor, the motors shall meet the shaft and base tolerances shown in Figure 36.

#### 9.3.8.2 Couplings and Guards

**9.3.8.2.1** Coupling faces shall be perpendicular to the axis of the coupling within 0.0001 in./in. (0.1  $\mu\text{m}/\text{mm}$ ) of face diameter or 0.0005 in. (13  $\mu\text{m}$ ) TIR, whichever is greater.

**9.3.8.2.2** For vertical pumps equipped with mechanical seals and without integral thrust bearings, the coupling shall be a rigid adjustable-type type with spacer length sufficient to permit replacement of the seal assembly, including the sleeve, without removal of the driver (see 7.2.2).

**9.3.8.2.3** For vertical pumps equipped with mechanical seals and with integral thrust bearings, the coupling arrangement shall have spacer length sufficient to permit replacement of the seal assembly, including the sleeve, without removal of the driver. One of the following arrangements may be provided:

- a) an all-metal flexible element, spacer-type coupling located between the thrust bearing and driver shafts, and no coupling between the mechanical seal and the thrust bearing housing;
- b) a rigid adjustable, spacer-type coupling between the pump and thrust bearing housing shafts, and an all-metal flexible element, non-spacer-type coupling between the thrust bearing and driver shafts (see Figure 42).

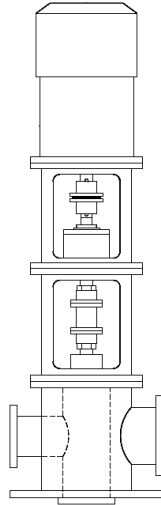
NOTE The second arrangement with two couplings enables seal replacement without disturbing and lifting the thrust bearing housing. The size and weight of the thrust bearing housing assembly is a consideration in selecting one of these arrangements.

#### 9.3.8.3 Mounting Plates

- **9.3.8.3.1** If specified, the mounting plate for double-casing pumps (VS6 and VS7) shall be separate from the main body flange and located sufficiently below it to permit the use of through-bolting on the body flange (see Figure 43).

NOTE The design shown in Figure 43 results in a higher joint integrity and is often used for critical and cryogenic services.

- **9.3.8.3.2** If specified, pumps shall be provided with a separate sole plate for bolting and grouting to the foundation (see Figure 43). This plate shall be machined on its top surface for mounting of the discharge head, can or motor support.



**Figure 42—Thrust Bearing Arrangement with Two Couplings**

**9.3.8.3.3** The outside corners of the sole plate or mounting plate imbedded in the grout shall have at least 2 in. (50 mm) radii in the plan view (see Figure D.1).

#### **9.3.8.4 Piping and Appurtenances**

If mechanical seals and drivers are not installed prior to shipment, the seal piping system shall not be fully assembled.

#### **9.3.9 Testing**

**9.3.9.1** Pumps shall be tested as complete assemblies. Tests using only bowls and impellers are not recommended. In cases where assembled-unit testing is impractical, the vendor shall submit alternative testing procedures with the proposal. Suction cans, if supplied, are not required for performance testing.

- **9.3.9.2** If specified, a resonance test with the pump unpiped shall be conducted on the pump structure/driver frame assembly. The test shall be performed as follows:
  - c) excite the assembly by making an impact on the driver frame in the direction of the discharge flange;
  - d) determine the natural frequencies by the response;
  - e) excite the assembly by making an impact on the driver frame at 90° to the direction of the discharge flange;
  - f) determine the natural frequencies by the response.

The natural frequencies so determined shall be at least 10 % below the minimum continuous operating speed or shall be at least 10 % above the maximum continuous operating speed.

#### **9.3.10 Single-case Diffuser (VS1) and Volute (VS2) Pumps**

**9.3.10.1** Line shafts may be open or enclosed. For enclosed line shafts, the type of lubrication shall be approved by the purchaser.

**NOTE** Open line-shafting is lubricated by the pumped liquid. If the pumped liquid is not suitable as a lubricant, enclosed line-shafting may be provided to ensure a clean lubrication supply for line-shaft bearings.

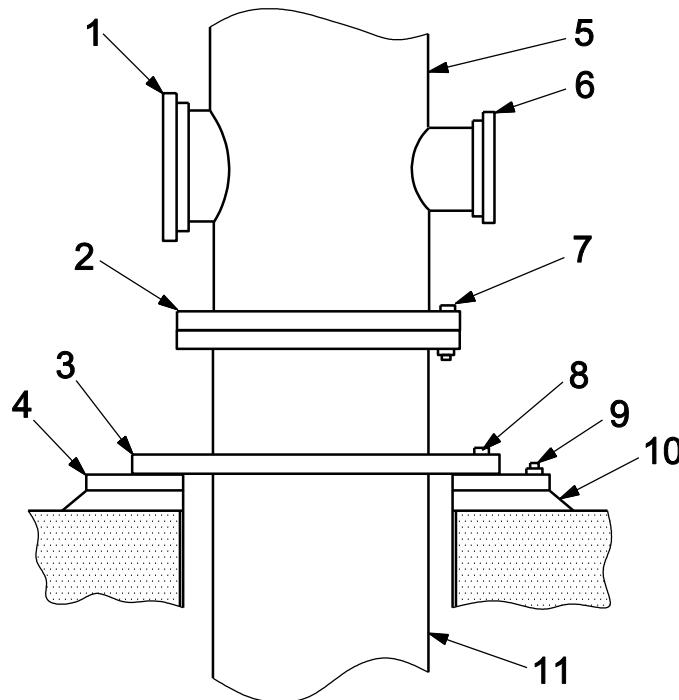
**9.3.10.2** The discharge-head mounting surface shall be suitable for both grouting and mounting on a machined sole plate.

**9.3.10.3** Thrust restraints are required at the pump if an expansion joint is installed on the discharge nozzle. Design review of the proposed installation and piping by the vendor is recommended.

- **9.3.10.4** If specified, bowl and line shaft bearings shall be furnished with hardened bearing journals under each bearing.

**9.3.10.5** Unless otherwise specified, integral bushing spiders and rabbeted fits shall be used for all column sizes.

**9.3.10.6** Unless otherwise specified, bowls shall be flanged and shall have metal-to-metal rabbeted fits.



**Key**

- |                    |  |
|--------------------|--|
| 1 suction flange   | 7 main body flange through-bolting (typical) |
| 2 main body flange | 8 hold-down bolts (typical)                  |
| 3 mounting flange  | 9 anchor bolts (typical)                     |
| 4 sole plate       | 10 grout                                     |
| 5 pump head        | 11 can (outer casing)                        |
| 6 discharge flange |  |

**Figure 43—Optional Mounting for Vertically Suspended, Double-case Pumps (VS6 and VS7) with Sole Plate**

**9.3.11 Single-casing Axial Flow (VS3) Pumps**

**9.3.11.1** Unless otherwise specified, integral bushing spiders and rabbeted fits shall be used for all column sizes.

**9.3.11.2** Bowls shall have metal-to-metal rabbeted fits.

### 9.3.12 Single-casing Line Shaft (VS4) and Cantilever (VS5) Pumps

**9.3.12.1** For VS4 pumps, bushings shall be provided to support the shaft and impeller.

**9.3.12.2** VS5 pumps shall comply with Items a) through d) as follows.

- a) The rotor shall be cantilevered from its bearing assembly. Submerged bottom bushings are not used to guide the shaft.
- b) The shaft stiffness shall limit total deflection, without the use of a casing bushing, such that the impeller does not contact the pump casing under the most severe dynamic conditions over the complete head-flow curve with a maximum diameter impeller and at the maximum speed and liquid density.
- c) Cantilever type pumps shall have their first dry critical speed, for their rotors, 30 % above their maximum allowable continuous speed.
- d) For cantilever-type VS5 pumps, the shaft TIR shall not exceed 0.002 in. (50  $\mu\text{m}$ ) as measured on the shaft directly above the mechanical seal or stuffing box.

**9.3.12.3** The components that constitute the pressure casing of VS4 and VS5 pumps are the casing, suction cover, and discharge line.

- **9.3.12.4** The purchaser shall specify whether sump-pump services for VS4 and VS5 pumps are open-system or closed-system arrangements. For closed-system arrangements with pressure-containing vessels or tanks, the purchaser shall specify the maximum pressure in the vessel or tank as the maximum suction pressure for the pumps.

**9.3.12.5** For VS4 and VS5 pumps in closed-system arrangements, cover-plate joints shall be vapor-tight as a minimum. For VS4 and VS5 pumps in closed-system arrangements with pressure-containing vessels or tanks, the seal chamber, pump cover plate and tank cover shall be designed to contain the maximum suction pressure specified. The cover-plate design and its mounting interface with the pump-mounting nozzle of the vessel or tank shall be agreed to by the purchaser and vendor.

**NOTE** For closed-system arrangements with single small sump pumps, the purchaser and vendor typically agree to pump-mounting nozzles which conform to the pressure ratings and dimensional requirements of ASME B16.5 and ASME B16.47. Larger sump pumps may require special pump-mounting nozzles to accommodate the weight and size of the equipment.

**9.3.12.6** For VS4 pumps, the thrust bearing shall be designed for either grease or oil lubrication. Bushings may be lubricated with water, grease or product, or be self-lubricated.

**9.3.12.7** Bearings for VS5 pumps shall be grease-lubricated. The stabilized bearing-housing temperature shall not exceed a 70 °F (39 K) rise above ambient temperature.

**9.3.12.8** Packing shall be supplied on VS4 and VS5 pumps except for closed-system services.

**9.3.12.9** Mechanical seals, if supplied, shall be located at the cover plate, to seal the vapor in the supply tank or vessel. Mechanical seals normally seal vapor; however, they shall be designed to operate in liquid in the event of tank or vessel overfilling. The seal chamber shall have provisions for a high-point vent.

**9.3.12.10** Lifting lugs shall be provided in the cover plate for lifting the pump assembly, including the driver.

**9.3.12.11** The discharge nozzle and cover plate shall be designed as required in 6.3.3.

**NOTE** For pumps are mounted in pressure vessels or tanks, the pump-mounting nozzle of the vessel or tank is designed to withstand the allowable nozzle loads. See 6.5 for allowable nozzle loads.

**9.3.12.12** Pump-out vanes may be used in lieu of wear rings to reduce leakage back to the sump.

**9.3.12.13** Typically, spacer couplings are not used on VS4 and VS5 pumps. Coupling hubs shall be supplied with slip fits to the shaft. The coupling hubs and keys shall be secured to the shaft with set-screws to facilitate final coupling adjustment.

### **9.3.13 Double-casing Diffuser (VS6) and Volute (VS7) Pumps**

- **9.3.13.1** If specified, bowls and column pipe shall be hydrostatically tested with liquid at a minimum of 1.5 times the maximum differential pressure developed by the bowl assembly. Hydrostatic testing shall be conducted in accordance with the requirements of 8.3.2.

**9.3.13.2** Complete outer-case venting shall be ensured by means of a high-point vent connection.

**9.3.13.3** Provision shall be made to ensure complete venting of the inner assembly within the seal chamber or associated auxiliary process piping.

- **9.3.13.4** If specified, the suction shall be supplied with a drain piped to the surface.

NOTE A drain is used to remove liquids inside the pump assembly that if not removed, can evaporate and cause a potential hazard when the pump is dismantled.

**9.3.13.5** Column sections shall incorporate integral bushing spiders and rabbeted fits for all column sizes.

- **9.3.13.6** If specified, bowl and line shaft bearings shall be furnished with hardened bearing journals under each bearing.

## **10 Vendor's Data**

- **10.1** The purchaser may specify the content of proposals, meeting frequency and vendor data content/format as described in Annex L. Annex L provides a general outline of information that potentially may be requested by the purchaser.
- **10.2** If specified, the information specified in Annex L shall be provided.

## Annex A (normative)

### Specific Speed and Suction-specific Speed

Specific speed,  $n_s$ , is an index number relating to a pump's performance at BEP flowrate with the maximum diameter impeller and at a given rotational speed. Specific speed is defined by Equation (A.1):

$$n_s = n(q)^{0.5}/H^{0.75} \quad (\text{A.1})$$

where

- $n$  is the rotational speed, expressed in revolutions per minute;
- $q$  is the total pump flowrate, expressed in U.S. gallons per minute (cubic meters per second);
- $H$  is the head per stage, expressed in feet (meters).

NOTE 1 Specific speed derived using USC units divided by a factor of 51.64 is equal to specific speed in SI units.

NOTE 2 For simplicity, industry omits the gravitational constant from the dimensionless equations for specific speed and suction-specific speed.

An alternative definition of specific speed is sometimes used (flowrate per impeller eye rather than total flowrate). The purchaser is cautioned to understand which definition is being used when comparing data.

Suction-specific speed,  $S$ , an index number relating to a pump's suction performance, is calculated at BEP flowrate with the maximum diameter impeller at a given rotational speed and is defined by Equation (A.2):

$$S = n(q)^{0.5}/(\text{NPSH3})^{0.75} \quad (\text{A.2})$$

where

- $n$  is the rotational speed, expressed in revolutions per minute;
- $q$  is the flowrate per impeller eye, expressed in U.S. gallons per minute (cubic meters per second) equal to one of the following:
  - total flowrate for single-suction impellers,
  - one-half the total flowrate for double-suction impellers;

(NPSH3) is the net positive suction head required, expressed in feet (meters).

NOTE 3 Suction-specific speed derived using USC units divided by a factor of 51.64 is equal to suction-specific speed in SI units.

NOTE 4 The USC symbol  $N_{ss}$  is sometimes used to designate suction-specific speed.

# Annex B (normative)

## Cooling Water Schematics

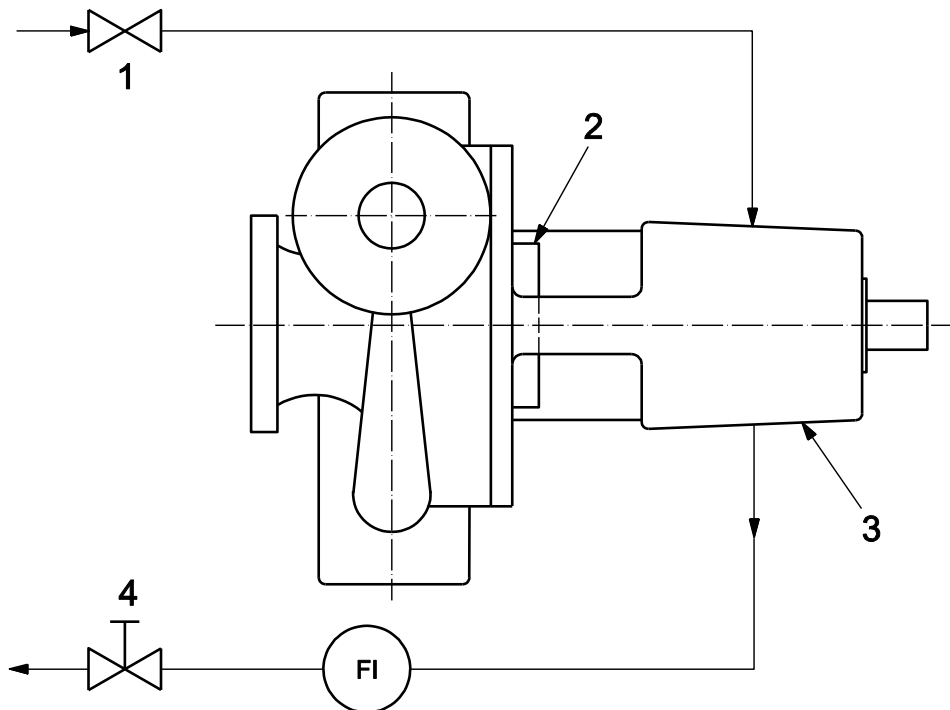
This annex contains schematic diagrams for cooling water systems. The symbols used in Figure B.2, Figure B.3, Figure B.4, Figure B.5, Figure B.6, Figure B.7, Figure B.8, and Figure B.9 are shown and identified in Figure B.1. These symbols represent commonly used systems. Other configurations and systems are available and may be used if specified or if agreed upon by the purchaser and the vendor.



**Key**

- |   |                    |    |                          |
|---|--------------------|----|--------------------------|
| 1 | heat exchanger     | 11 | flow-regulating valve    |
| 6 | flowrate indicator | 12 | block valve (gate valve) |

**Figure B.1—Symbols Used in Figures B.2 to B.7**

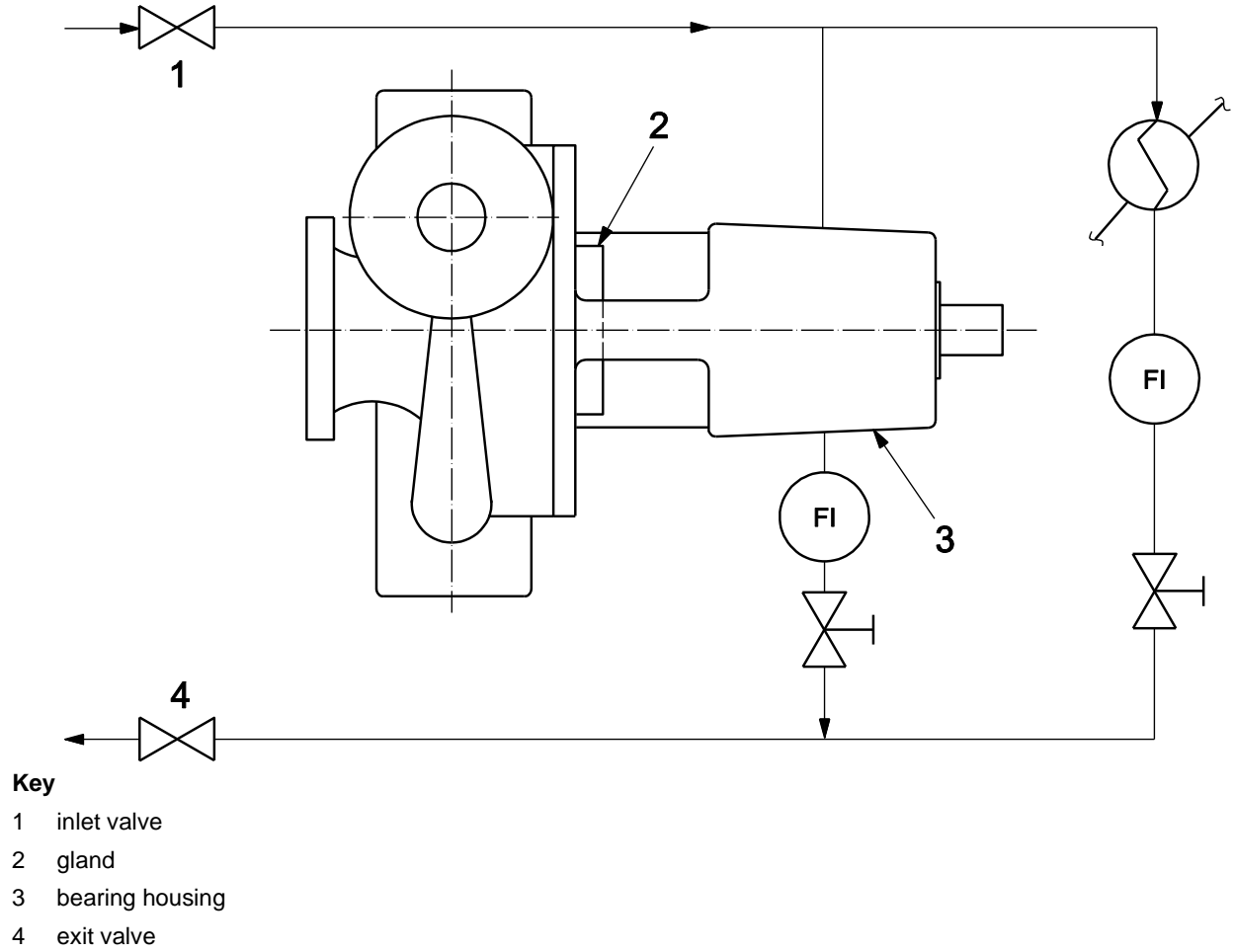


**Key**

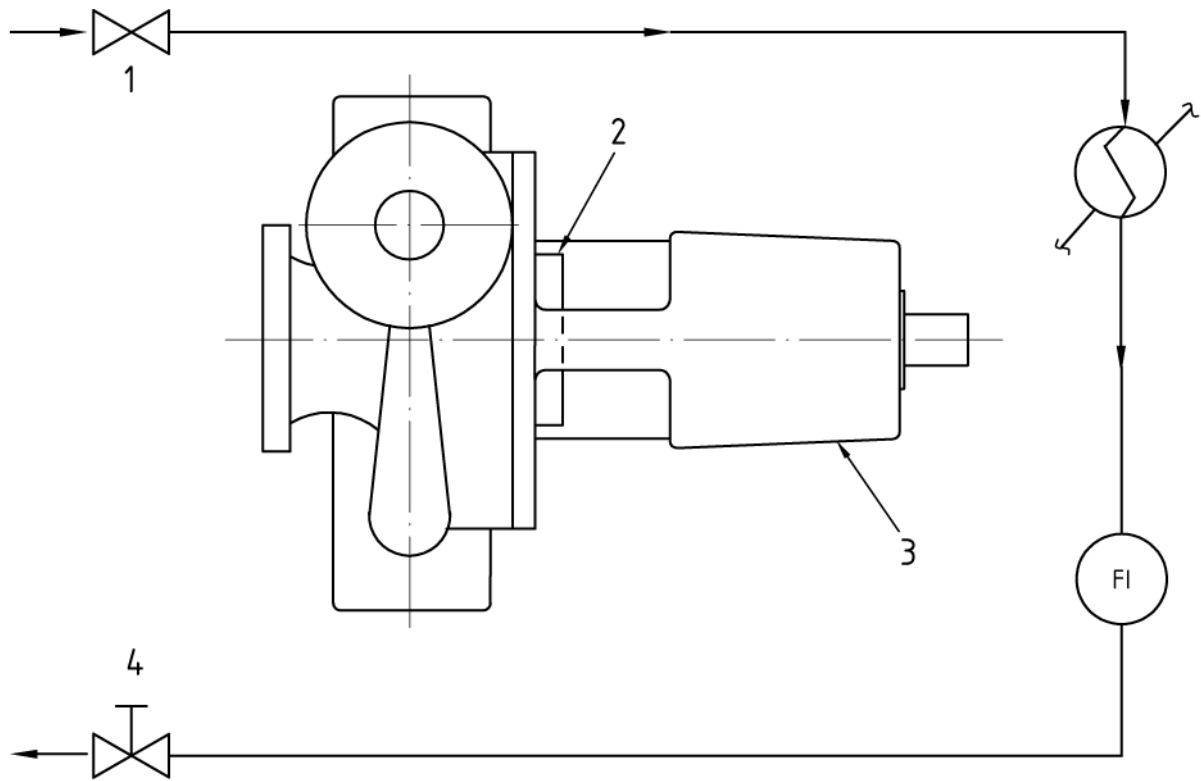
- 1 inlet valve
- 2 gland
- 3 bearing housing
- 4 exit valve

**Figure B.2—Piping for Overhung Pumps—Plan A, Cooling to Bearing Housing**



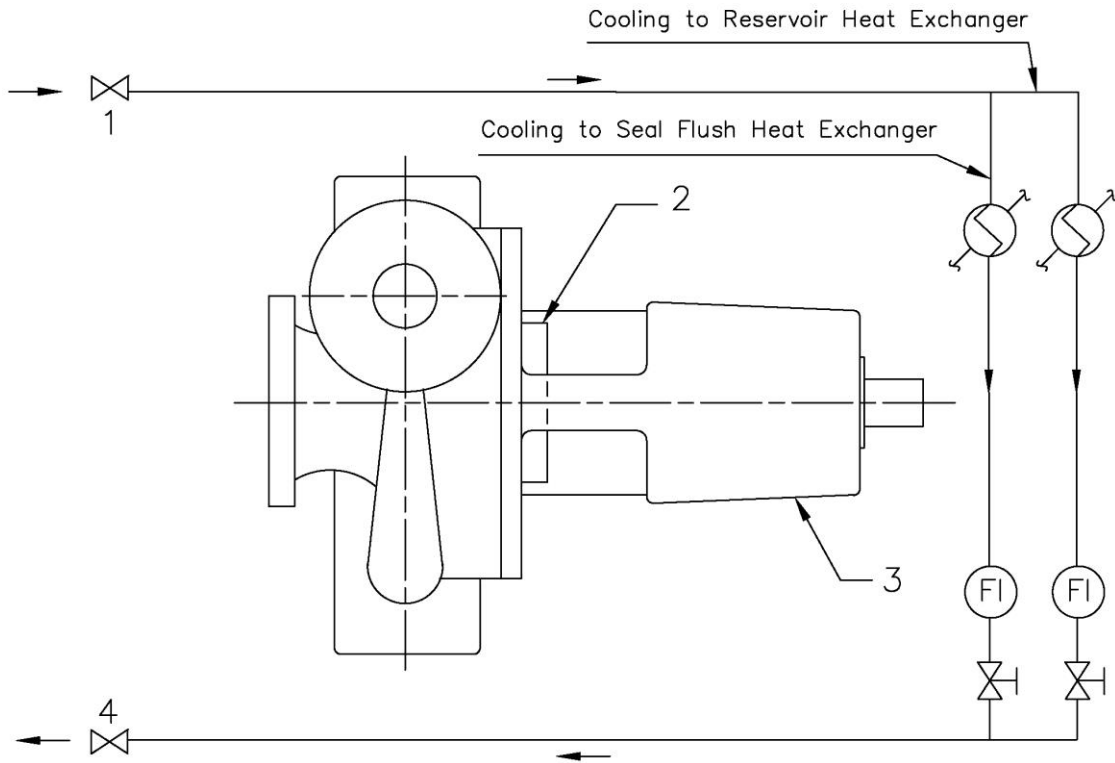


**Figure B.3—Piping for Overhung Pumps—Plan K, Cooling to Bearing Housing with Parallel Flow to Seal Heat Exchanger**

**Key**

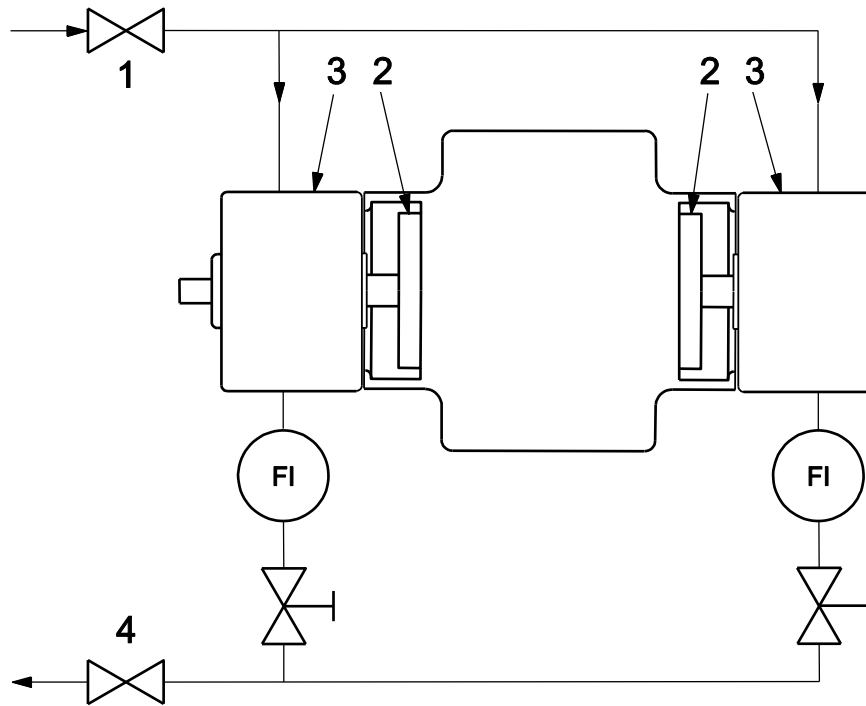
- 1 inlet valve
- 2 gland
- 3 bearing housing
- 4 exit valve

**Figure B.4—Piping for Overhung Pumps—Plan M, Cooling to Seal Heat Exchanger**

**Key**

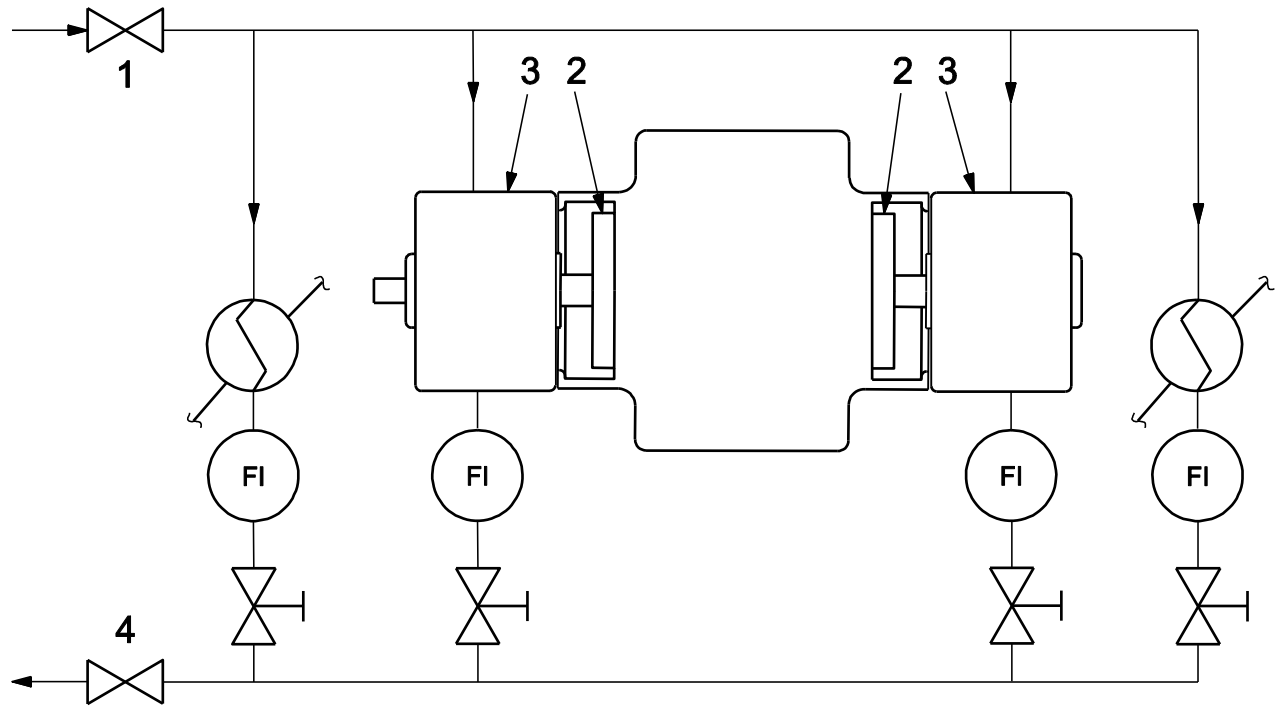
- 1 inlet valve
- 2 gland
- 3 bearing housing
- 4 exit valve

**Figure B.5—Piping for Overhung Pumps—Plan M, Cooling to Seal Heat Exchanger and Reservoir**

**Key**

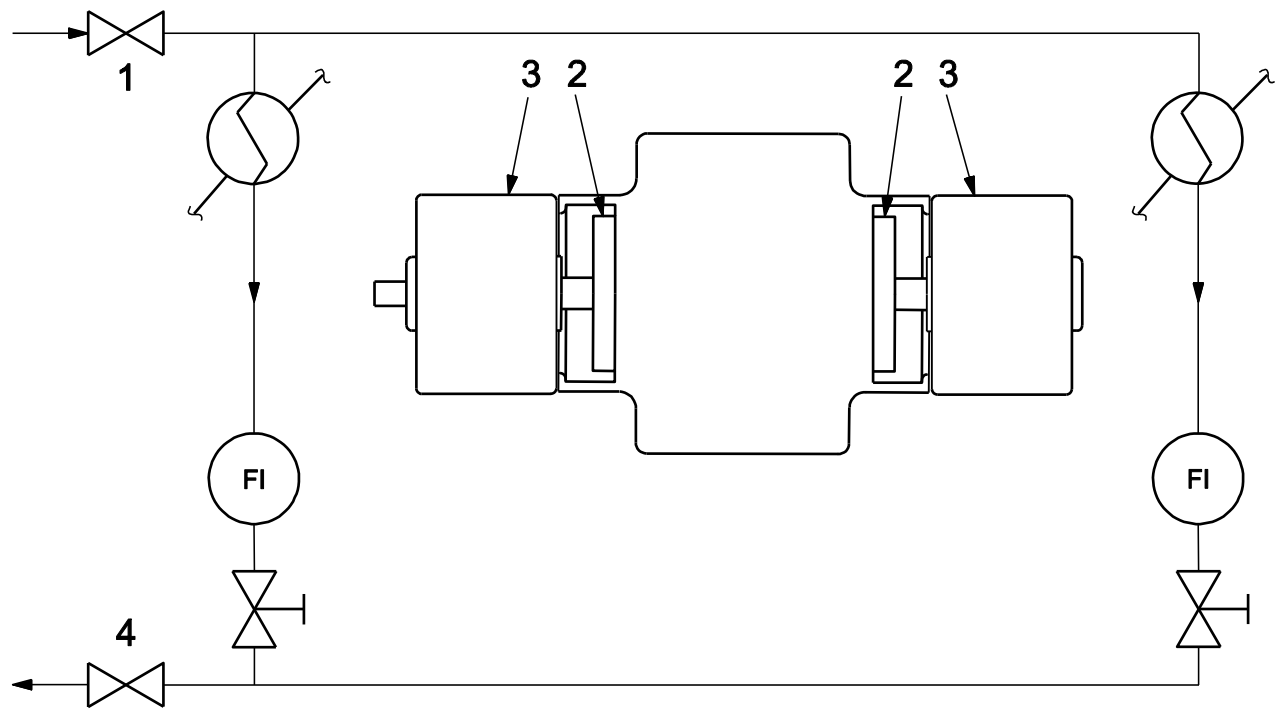
- 1 inlet valve
- 2 gland
- 3 bearing housing
- 4 exit valve

**Figure B.6—Piping for Between-bearing Pumps—Plan A, Cooling to Bearing Housings**

**Key**

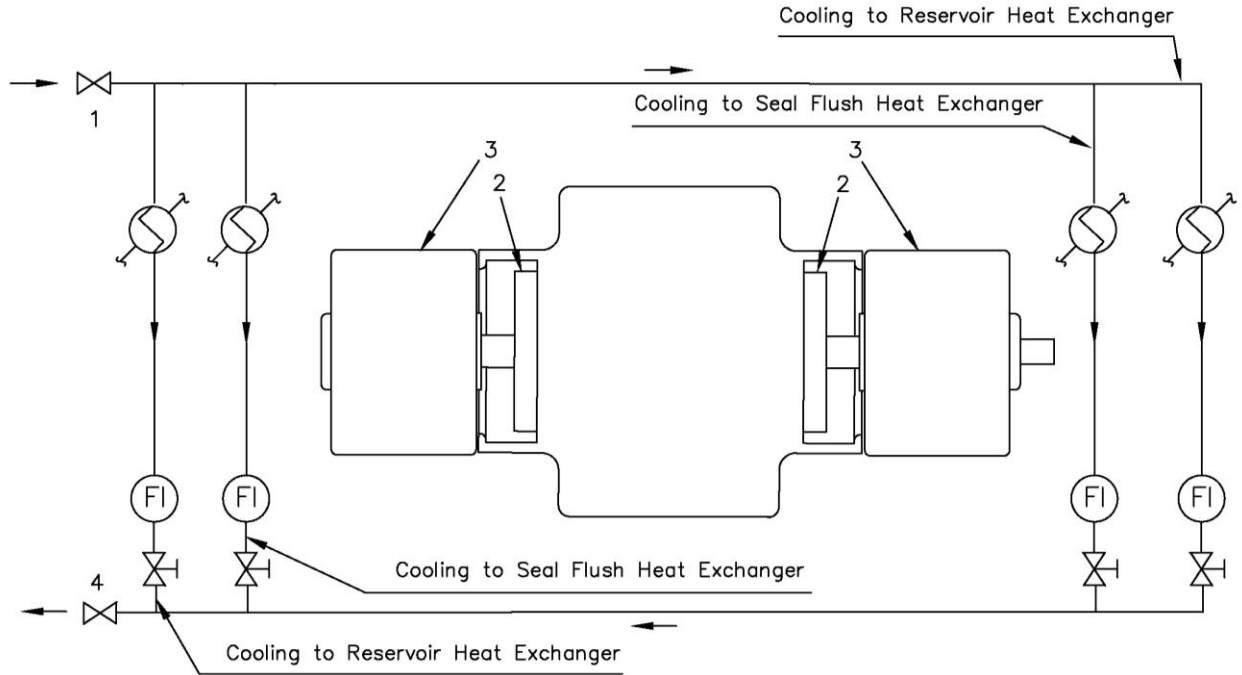
- 1 inlet valve
- 2 gland
- 3 bearing housing
- 4 exit valve

**Figure B.7—Piping for Between-bearing Pumps—Plan K, Cooling to Bearing Housings with Parallel Flow to Seal Heat Exchangers**

**Key**

- 1 inlet valve
- 2 gland
- 3 bearing housing
- 4 exit valve

**Figure B.8—Piping for Between-bearing Pumps—Plan M, Cooling to Seal Heat Exchangers**

**Key**

- 1 inlet valve
- 2 gland
- 3 bearing housing
- 4 exit valve

**Figure B.9—Piping for Between-bearing Pumps—Plan M,  
Cooling to Seal Heat Exchangers and Reservoirs**

## **Annex C** (normative)

### **Hydraulic Power Recovery Turbines**

#### **C.1 General**

This annex applies to hydraulic power recovery turbines (HPRTs).

Power recovery is generally achieved by the reduction of liquid pressure, sometimes with a contribution from vapor or gas evolution during the pressure reduction. A HPRT may be a pump operated with reverse flow.

#### **C.2 Terminology**

This standard uses terms that need to be changed or ignored if the standard is applied to HPRTs. The direction of flow through the HPRT is the reverse of that through the pump. In such a context, the word “pump” may be interpreted as meaning “HPRT,” the term “pump suction” should be interpreted as meaning the “HPRT outlet,” and the term “pump discharge” should be interpreted as meaning the “HPRT inlet.”

#### **C.3 Design**

##### **C.3.1 Liquid Characteristics**

- **C.3.1.1** The purchaser shall advise the HPRT manufacturer whether any portion of the process stream entering the HPRT can flash to vapor and whether absorbed gas in the stream can evolve at any pressure less than the inlet pressure.
- **C.3.1.2** The purchaser shall specify the volume percentage of vapor or gas, or both, at the turbine outlet and the pressure and temperature at which the vapor can flash off.

**C.3.1.3** If known, the liquid composition, and the liquid and vapor (or gas) density vs pressure, should also be specified. It can be necessary to control the HPRT outlet pressure to limit the amount of liquid that flashes to vapor or the amount of gas coming out of solution.

##### **C.3.2 Seal-flushing System**

To avoid shortening seal life, consideration shall be given to the evolution of gas and vaporization in seal-flushing streams. If this potential exists, a seal flush from other than the HPRT inlet is generally recommended.

##### **C.3.3 Overspeed Trip**

**C.3.3.1** An overspeed trip shall be provided if the HPRT and other equipment in the train cannot tolerate the calculated runaway speed (the maximum speed reached by the HPRT if unloaded and subjected to the worst combination of specified inlet and outlet conditions). Typically, overspeed trips are set in the range of 115 % to 120 % of rated speed.

NOTE 1 It is important to realize that runaway speed with inlet liquids rich in absorbed gas or with liquids that partially flash as they flow through the HPRT can be several times higher than the runaway speed with water. With such liquids, the runaway speed cannot be accurately determined.

NOTE 2 The risk of overspeed is reduced if the driven equipment, such as a pump or fan, cannot realistically be expected to lose load. The risk is increased if the driven equipment is a generator, since a sudden disconnection from electric power circuits unloads the HPRT.



- **C.3.3.2** If specified, a quick-acting brake system to prevent overspeed due to accidental unloading shall be provided.

### **C.3.4 Dual Drivers**

NOTE See Figure C.1 a) and Figure C.1 b).

**C.3.4.1** If a HPRT is used to assist another driver, the considerations in C.3.4.2 through C.3.4.5 apply.

**C.3.4.2** The main driver shall be rated to drive the train without assistance from the HPRT.

**C.3.4.3** An overrunning clutch (that is a clutch that transmits torque in one direction and freewheels in the other) shall be used between the HPRT and the train to allow the driven equipment to operate during HPRT maintenance and to permit start-up of the train before the HPRT process stream is lined up.

**C.3.4.4** Flow to the HPRT can vary widely and frequently. If the flow drops to about 40 % of the rated flow, the HPRT stops producing power and a drag can be imposed on the main driver. An overrunning clutch prevents this drag.

**C.3.4.5** The HPRT shall not be positioned between the main driver and the driven equipment.

### **C.3.5 Generators**

NOTE See Figure C.1 c).

If a generator is driven by a HPRT on a gas-rich process stream, the generator should be generously sized. The output power of HPRTs can be as much as 20 % to 30 % or more above that predicted by water tests, as a result of the effects of evolved gas or flashed liquid.

### **C.3.6 Throttle Valves**

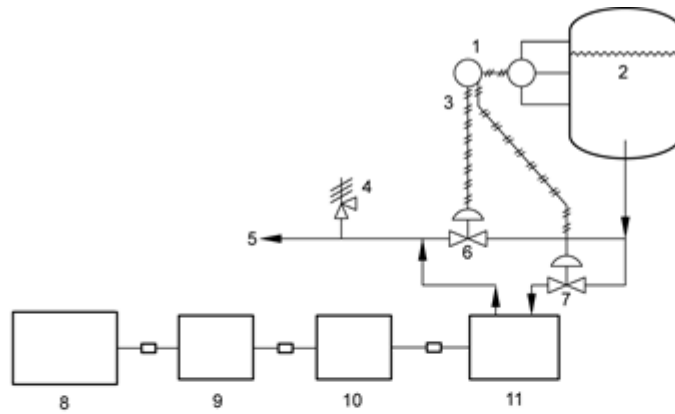
For most applications, valves used to control flow to the HPRT should be placed upstream and near the inlet of the HPRT (see Figure C.1). Placement upstream allows the mechanical seals to operate at the outlet pressure of the HPRT and, for gas-rich streams, permits the gas to evolve, which increases the power output.

### **C.3.7 Bypass Valves**

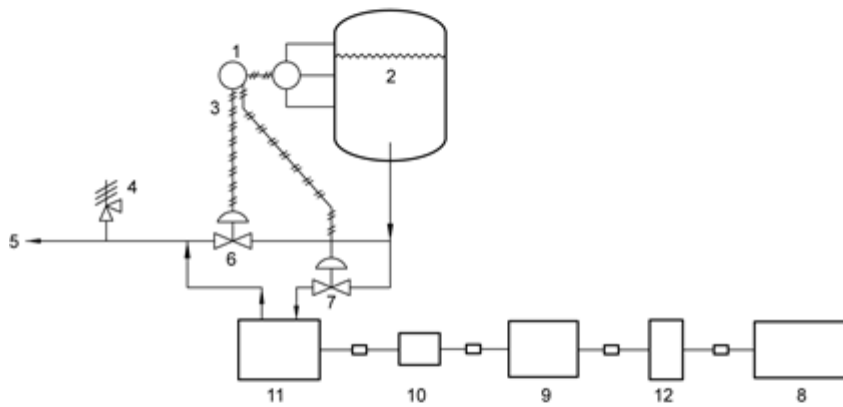
Regardless of the arrangement of the HPRT train, a full-flow bypass valve with modulation capability should be installed. Common control of the modulating bypass valve and the HPRT inlet control valve is normally achieved by means of a split-level arrangement (see Figure C.1).

### **C.3.8 Relief Valves**

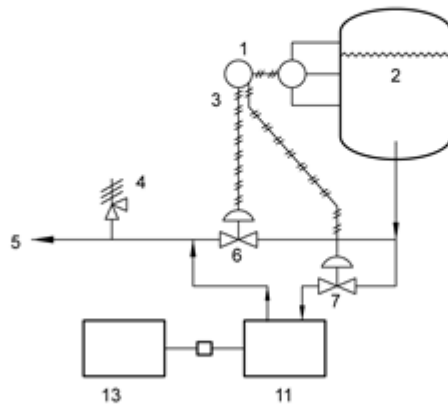
To protect the HPRT outlet casing integrity and mechanical seals from possible downstream back-pressure transients, a relief valve installed in the HPRT outlet piping circuit should be considered (see Figure C.1).



a) Pump Drive at Motor Speed



b) Pump Drive at Greater than Motor Speed



c) Generator Drive

**Key**

- |                               |                        |                       |
|-------------------------------|------------------------|-----------------------|
| 1 level indicator, controller | 6 bypass               | 10 overrunning clutch |
| 2 high-pressure source        | 7 inlet throttle valve | 11 HPRT               |
| 3 split range                 | 8 pump                 | 12 gear               |
| 4 relief valve                | 9 motor                | 13 generator          |
| 5 low-pressure destination    |                        |                       |

**Figure C.1—Typical HPRT Arrangements**

## C.4 Testing

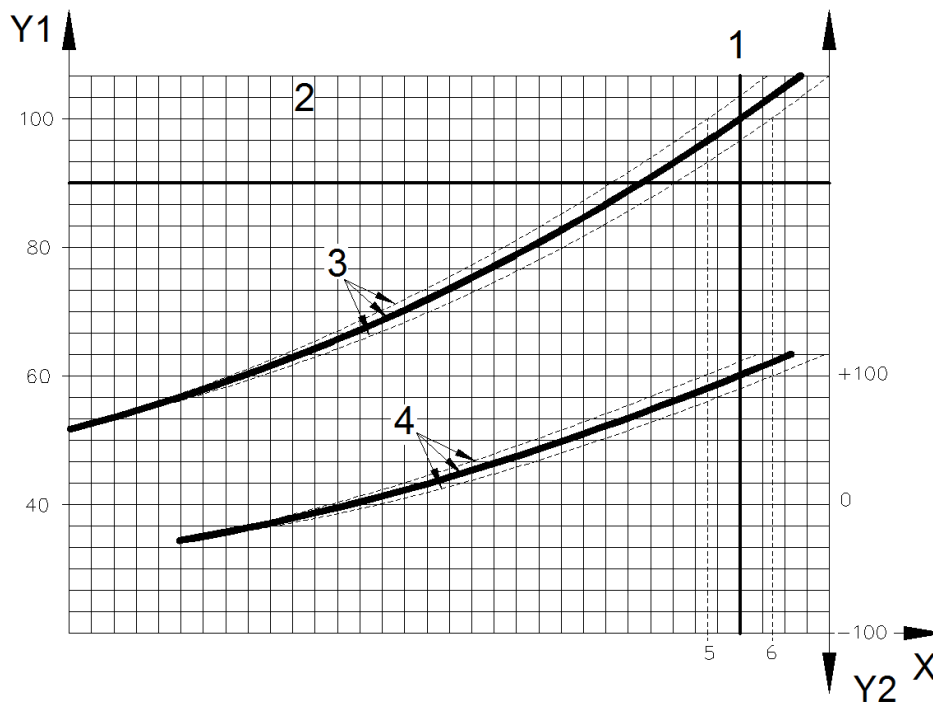
**C.4.1** The HPRT shall receive a performance test at the manufacturer's test facility. Hydraulic and mechanical performance guarantees shall be based on water testing.

**C.4.2** Figure C.2 shows recommended test performance tolerances for HPRTs. The pump criteria given in the main body of this standard are not applicable.

**C.4.3** Vibration levels for HPRTs shall meet the criteria for pumps given in the main body of this standard.

- **C.4.4** If specified, the overspeed trip setting for the HPRT shall be verified at the manufacturer's test facility. If required, overspeed trip devices shall be checked and adjusted until values within 1 % of the nominal trip setting are attained. Mechanical overspeed devices shall attain three consecutive non-trending trip values that meet this criterion.

**NOTE** Determining the runaway speed during a water test can be considered, but this speed can be accurately calculated once performance with water is known. Runaway speed for gas-rich steams cannot be determined by water tests.



### Key

- X flowrate
- Y1 differential head, expressed as a percentage
- Y2 rated power, expressed as a percentage
- 1 rated flow
- 2 rated head
- 3 typical head vs flowrate curve
- 4 typical power vs flowrate curve
- 5 low-side tolerance (95 %)
- 6 high-side tolerance (105 %)

**Figure C.2—HPRT Test Performance Tolerances**

## Annex D (informative)

### Standard Baseplates

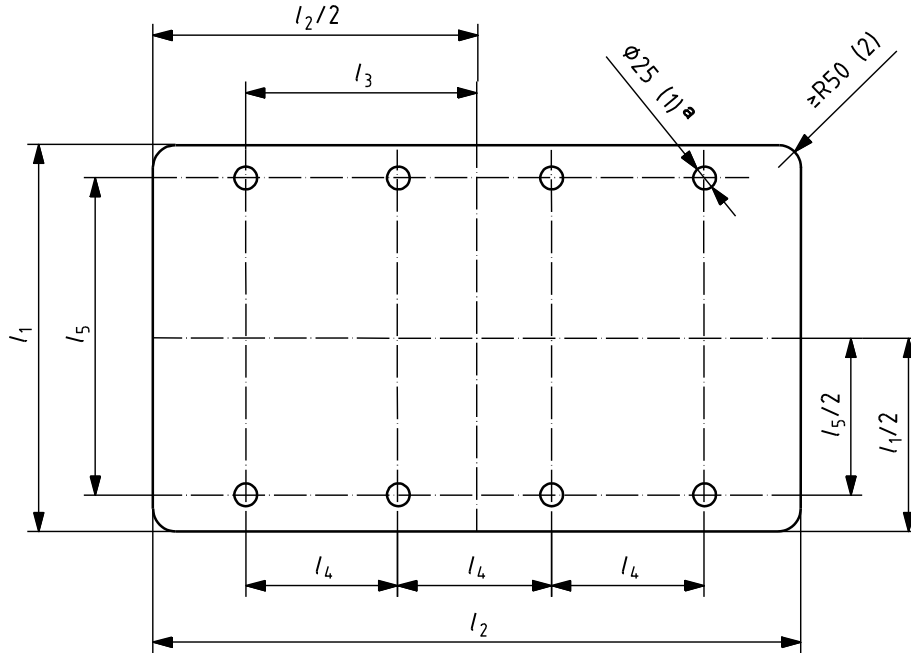
**Table D.1—Dimensions of Standard Baseplates**

Dimensions in inches (millimeters)

Baseplate Number	Number of Holes per Side	$l_1$ ± 0.5 (13)	$l_2$ ± 1.0 (25)	$l_3$ ± 0.12 (3)	$l_4$ ± 0.12 (3)	$l_5$ ± 0.12 (3)
2.5	3	36.0 (915)	60.5 (1535)	24.25 (615)	24.25 (615)	33.0 (840)
3	3	36.0 (915)	72.5 (1840)	30.25 (770)	30.25 (770)	33.0 (840)
3.5	4	36.0 (915)	84.5 (2145)	36.25 (920)	24.16 (615)	33.0 (840)
4	4	36.0 (915)	96.5 (2450)	42.25 (1075)	28.16 (715)	33.0 (840)
5	3	42.0 (1065)	72.5 (1840)	30.25 (770)	30.25 (770)	39.0 (990)
5.5	4	42.0 (1065)	84.5 (2145)	36.25 (920)	24.16 (615)	39.0 (990)
6	4	42.0 (1065)	96.5 (2450)	42.25 (1075)	28.16 (715)	39.0 (990)
6.5	5	42.0 (1065)	108.5 (2755)	48.25 (1225)	24.12 (615)	39.0 (990)
7	4	49.0 (1245)	84.5 (2145)	36.25 (920)	24.16 (615)	46.0 (1170)
7.5	4	49.0 (1245)	96.5 (2450)	42.25 (1075)	28.16 (715)	46.0 (1170)
8	5	49.0 (1245)	108.5 (2755)	48.25 (1225)	24.12 (615)	46.0 (1170)
9	4	55.0 (1395)	84.5 (2145)	36.25 (920)	24.16 (615)	52.0 (1320)
9.5	4	55.0 (1395)	96.5 (2450)	42.25 (1075)	28.16 (715)	52.0 (1320)
10	5	55.0 (1395)	108.5 (2755)	48.25 (1225)	24.12 (615)	52.0 (1320)
11	4	61.0 (1550)	84.5 (2145)	36.25 (920)	24.16 (615)	58.0 (1475)
11.5	4	61.0 (1550)	96.5 (2450)	42.25 (1075)	28.16 (715)	58.0 (1475)
12	5	61.0 (1550)	108.5 (2755)	48.25 (1225)	24.12 (615)	58.0 (1475)

NOTE See Figure D.1 for explanation of dimensions.

Dimensions in inches (millimeters)



<sup>a</sup> For  $\frac{3}{4}$  in. (20 mm) anchor bolts.

**Figure D.1—Standard Baseplate**

## Annex E (informative)

### Inspector's Checklist

The levels indicated in Table E.1 may be characterized as follows:

- Level 1 is typically used for pumps in general services;
- Level 2 comprises performance and material requirements and is more stringent than Level 1;
- Level 3 items are considered for pumps in critical services.

The required inspection shall be indicated in the first column as follows.

- C: Certification only.
- O: Observed inspection.
- W: Witnessed inspection.

**Table E.1—Inspector's Checklist**

Inspection required C, O, or W	Item	API 610 Subsection	Date Inspected	Inspected by	Status
<b>Level 1—Basic</b>					
	Casing marking (serial no.)	6.13.3			
	Motors and electrical components area classification	6.1.29			
	Casing jackscrews	6.3.17			
	Nozzle size, rating, and finish <sup>a</sup>	Outline drawing, 6.4.1.1, 6.4.2			
	Baseplate requirements	7.4			
	Certified hydrostatic test	8.3.2			
	Performance within tolerance (certified)	8.3.3.4.3			
	NPSH3 within tolerance (certified)	8.3.4.3.4			
	Vibration within tolerance (certified)	8.3.3.6.1			
	Rotation arrow	6.13.4			
	Overall dimensions and connection locations <sup>a</sup>	Outline drawing			
	Anchor bolt layout and size <sup>a</sup>	Outline drawing			
	Auxiliary piping flow diagram	Annex B			
	Piping fabrication and installation	7.5			
	Equipment nameplate data	6.13.2			

**Table E.1—Inspector's Checklist (Continued)**

Inspection required C, O, or W	Item	API 610 Subsection	Date inspected	Inspected by	Status
	Oil and bearing temperature (certified)	6.10.2.7			
<b>Level 1—Basic</b>					
	Restrained rotor	8.4.3.1			
	Storage preservation instructions	8.4.8			
	Rust prevention	8.4.3.2, 8.4.3.3, 8.4.3.5, 8.4.3.7, 8.4.3.9, 8.4.13			
	Painting	8.4.3.4			
	Preparation for shipment	8.4.2, 8.4.3.6, 8.4.3.8			
	Shipping documents and tags	8.4.6, 8.4.4, 8.4.7			
<b>Level 2—Intermediate (add to Level 1)</b>					
	Copies of subvendor purchase order				
	Material certification	6.12.1.8			
	Nondestructive examination (components)	6.12.1.6, 8.2.2.1			
	Hydrostatic test (witnessed)	8.3.2			
	Building records (runouts, clearances)	6.6.7, 6.6.9, 6.6.10, 6.6.13, 6.7.4, 9.2.2.4, 9.3.3.1, 9.3.4.2, 9.3.8.2.1, 9.3.12.2 d)			
	Performance and NPSH tests (witnessed)	8.3.3, 8.3.4.3			
<b>Level 3—Special (add to Levels 1 and 2)</b>					
	Welding procedures approved	6.12.3.1			
	Welding repairs approved	6.12.3.2			
	Welding repair maps	None			
	Impeller/rotor balancing	6.9.4, 9.2.4.2			
	Bearing inspection after testing	9.2.7.4			
	Nozzle forces and moments test	7.4.24			
	Mechanical run test	8.3.4.2			
	Complete unit test	8.3.4.4			
	Sound level test	8.3.4.5			
	Auxiliary equipment test	8.3.4.6			
	Resonance test (bearing housing)	8.3.4.7, 9.3.9.2			
<sup>a</sup> Check against certified dimensional outline drawing.					

## Annex F (normative)

### Criteria for Piping Design

#### F.1 Horizontal Pumps

**F.1.1** Acceptable piping configurations should not cause excessive misalignment between the pump and driver. Piping configurations that produce component nozzle loads lying within the ranges specified in Table 5 limit casing distortion to one-half the pump vendor's design criterion (see 6.3.3) and ensure pump shaft displacement of less than 0.010 in. (250  $\mu\text{m}$ ).

**F.1.2** Piping configurations that produce loads outside the ranges specified in Table 5 are also acceptable without consultation with the pump vendor if the conditions specified in F.1.2 a) through F.1.2 c) as follows are satisfied. Satisfying these conditions ensures that any pump casing distortion is within the vendor's design criteria (see 6.3.3) and that the displacement of the pump shaft is less than 0.015 in. (380  $\mu\text{m}$ ).

- a) The individual component forces and moments acting on each pump nozzle flange shall not exceed the range specified in Table 5 (T4) by a factor of more than 2.
- b) The resultant applied force ( $F_{RSA}$ ,  $F_{RDA}$ ) and the resultant applied moment ( $M_{RSA}$ ,  $M_{RDA}$ ) acting on each pump-nozzle flange shall satisfy the appropriate interaction equations as given in Equations (F.1) and (F.2):

$$[F_{RSA}/(1.5 \times F_{RST4})] + [M_{RSA}/(1.5 \times M_{RST4})] < 2 \quad (\text{F.1})$$

$$[F_{RDA}/(1.5 \times F_{RDT4})] + [M_{RDA}/(1.5 \times M_{RDT4})] < 2 \quad (\text{F.2})$$

- c) The applied component forces and moments acting on each pump nozzle flange shall be translated to the center of the pump. The magnitude of the resultant applied force,  $F_{RCA}$ , the resultant applied moment,  $M_{RCA}$ , and the applied moment shall be limited by Equations (F.3) to (F.5). (The sign convention shown in Figure 21, Figure 22, Figure 23, Figure 24, and Figure 25 and the right-hand rule should be used in evaluating these equations.)

$$F_{RCA} < 1.5(F_{RST4} + F_{RDT4}) \quad (\text{F.3})$$

$$|M_{YCA}| < 2.0(M_{YST4} + M_{YDT4}) \quad (\text{F.4})$$

$$M_{RCA} < 1.5(M_{RST4} + M_{RDT4}) \quad (\text{F.5})$$

where

$$F_{RCA} = [(F_{XCA})^2 + (F_{YCA})^2 + (F_{ZCA})^2]^{0.5} \quad (\text{F.3.1})$$

where

$$F_{XCA} = F_{XSA} + F_{XDA} \quad (\text{F.3.1.1})$$

$$F_{YCA} = F_{YSA} + F_{YDA} \quad (\text{F.3.1.2})$$

$$F_{ZCA} = F_{ZSA} + F_{ZDA} \quad (\text{F.3.1.3})$$

$$M_{RCA} = [(M_{XCA})^2 + (M_{YCA})^2 + (M_{ZCA})^2]^{0.5} \quad (\text{F.5.1})$$



where

$$M_{XCA} = M_{XSA} + M_{XDA} - [(F_{YSA})(zS) + (F_{YDA})(zD) - (F_{ZSA})(yS) - (F_{ZDA})(yD)]/12 \quad (\text{F.5.1.1})$$

$$M_{YCA} = M_{YSA} + M_{YDA} + [(F_{XSA})(zS) + (F_{XDA})(zD) - (F_{ZSA})(xS) - (F_{ZDA})(xD)]/12 \quad (\text{F.5.1.2})$$

$$M_{ZCA} = M_{ZSA} + M_{ZDA} - [(F_{XSA})(yS) + (F_{XDA})(yD) - (F_{YSA})(xS) - (F_{YDA})(xD)]/12 \quad (\text{F.5.1.3})$$

In SI units, the constant 12 shall be changed to 1000. This constant is the conversion factor to change inches to feet or millimeters to meters.

**F.1.3** Piping configurations that produce loads greater than those allowed in F.1.2 shall be approved by the purchaser and the vendor. To evaluate the actual machine distortion (at ambient conditions), the piping alignment checks required in API 686:2009, Chapter 6, should be performed.

NOTE API 686 allows only a small fraction of the permitted distortion resulting from use of the values from this annex.

## F.2 Vertical In-line Pumps

Vertical in-line pumps (OH3 and OH6) that are supported only by the attached piping can be subjected to component piping loads that are more than double the values shown in Table 5 if these loads do not cause a principal stress greater than 5950 psi (41 N/mm<sup>2</sup>) in either nozzle. For calculation purposes, the section properties of the pump nozzles shall be based on Schedule 40 pipe whose nominal size is equal to that of the appropriate pump nozzle. Equations (F.6), (F.7), and (F.8) can be used to evaluate the principal stress, the longitudinal stress, and the shear stress, respectively, in the nozzles.

For SI units, Equations (F.6) to (F.8) apply:

$$\sigma_p = (\sigma/2) + (\sigma^2/4 + \tau^2)^{0.5} < 41 \quad (\text{F.6})$$

$$\sigma_l = [1.27F_Y/(D_o^2 - D_i^2)] + [10,200D_o(M_X^2 + M_Z^2)^{0.5}]/(D_o^4 - D_i^4) \quad (\text{F.7})$$

$$\tau = [1.27(F_X^2 + F_Z^2)^{0.5}]/(D_o^2 - D_i^2) + [5100D_o(|M_Y|)]/(D_o^4 - D_i^4) \quad (\text{F.8})$$

For USC units, Equations (F.9) to (F.11) apply:

$$\sigma_p = (\sigma/2) + (\sigma^2/4 + \tau^2)^{0.5} < 5950 \quad (\text{F.9})$$

$$\sigma_l = [1.27F_Y/(D_o^2 - D_i^2)] + [122D_o(M_X^2 + M_Z^2)^{0.5}]/(D_o^4 - D_i^4) \quad (\text{F.10})$$

$$\tau = [1.27(F_X^2 + F_Z^2)^{0.5}]/(D_o^2 - D_i^2) + [61D_o(|M_Y|)]/(D_o^4 - D_i^4) \quad (\text{F.11})$$

where

- $\sigma_p$  is the principal stress, expressed in pounds-force per square inch (megapascals);
- $\sigma_l$  is the longitudinal stress, expressed in pounds-force per square inch (megapascals);
- $\tau$  is the shear stress, expressed in pounds-force per square inch (megapascals);
- $F_X$  is the applied force on the X axis;
- $F_Y$  is the applied force on the Y axis;
- $F_Z$  is the applied force on the Z axis;

$M_X$  is the applied moment on the X axis;

$M_Y$  is the applied moment on the Y axis;

$M_Z$  is the applied moment on the Z axis;

$D_i, D_o$  are the inner and outer diameters of the nozzles, expressed in inches (millimeters).

$F_X, F_Y, F_Z, M_X, M_Y,$  and  $M_Z$  represent the applied loads acting on the suction or discharge nozzles, thus subscripts  $S_A$  and  $D_A$  have been omitted to simplify the equations. The sign of  $F_Y$  is positive if the load puts the nozzle in tension; the sign is negative if the load puts the nozzle in compression. Reference can be made to Figure 21 and the applied nozzle loads to determine whether the nozzle is in tension or compression. The absolute value of  $M_Y$  should be used in Equations (F.8) and (F.11).

### F.3 Nomenclature

The following definitions apply to the sample problems in F.4.

**C** is the center of the pump. For pump types OH2, BB2, and BB5 with two support pedestals, the center is defined by the intersection of the pump shaft centerline and a vertical plane passing through the center of the two pedestals (see Figure 24 and Figure 25). For pump types BB1, BB3, and BB5 with four support pedestals, the center is defined by the intersection of the pump shaft centerline and a vertical plane passing midway between the four pedestals (see Figure 23);

**D** is the discharge nozzle;

$D_i$  is the inside diameter of Schedule 40 pipe whose nominal size is equal to that of the pump nozzle in question, expressed in inches (millimeters);

$D_o$  is the OD of Schedule 40 pipe whose nominal size is equal to that of the pump nozzle in question, expressed in inches (millimeters);

$F$  is the force, expressed in pounds force (newtons);

$F_R$  is the resultant force;  $F_{RSA}$  and  $F_{RDA}$  are calculated by the square root of the sum of the squares method using the applied component forces acting on the nozzle flange;  $F_{RST4}$  and  $F_{RDT4}$  are extracted from Table 5, using the appropriate nozzle size;

$M$  is the moment, expressed in foot-pounds force (newton meters);

$M_R$  is the resultant moment;  $M_{RSA}$  and  $M_{RDA}$  are calculated by the square root of the squares method using the applied component moments acting on the nozzle flange;  $M_{RST4}$  and  $M_{RDT4}$  are extracted from Table 5 using the appropriate nozzle size;

$\sigma_l$  is the longitudinal stress, expressed in pounds per square inch (newtons per square millimeter);

$\sigma_p$  is the principal stress, expressed in pounds force per square inch (megapascals);

$\tau$  is the shear stress, expressed in pounds per square inch (newtons per square millimeter);

**S** is the suction nozzle;

$x, y, z$  are the location coordinates of the nozzle flanges with respect to the center of the pump, expressed in inches (millimeters);

$X, Y, Z$  are the directions of the load (see Figure 21, Figure 22, Figure 23, Figure 24, and Figure 25);

Subscript A is an applied load;

Subscript T4 is a load extracted from Table 5.

## F.4 Sample Problems <sup>15</sup>

### F.4.1 Example 1A—SI Units

#### F.4.1.1 Problem

For an overhung-end suction process pump (OH2), the nozzle sizes and location coordinates are as given in Table F.1. The applied nozzle loadings are as given in Table F.2. The problem is to determine whether the conditions specified in F.1.2 a), F.1.2 b), and F.1.2 c) are satisfied.

#### F.4.1.2 Solution

**F.4.1.2.1** A check of condition F.1.2 a) is as follows.

For the DN 250 end suction nozzle:

$$|F_{XSA}/F_{XST4}| = | +12,900/6670 | = 1.93 < 2.00$$

$$|F_{YSA}/F_{YST4}| = | 0/5340 | = 0 < 2.00$$

$$|F_{ZSA}/F_{ZST4}| = | -8852/4450 | = 1.99 < 2.00$$

$$|M_{XSA}/M_{XST4}| = | -1356/5020 | = 0.27 < 2.00$$

$$|M_{YSA}/M_{YST4}| = | -5017/2440 | = 2.06 > 2.00$$

$$|M_{ZSA}/M_{ZST4}| = | -7458/3800 | = 1.96 < 2.00$$

Since  $M_{YSA}$  exceeds the value specified in Table 5 (SI units) by more than a factor of 2, it is not satisfactory. Assume that  $M_{YSA}$  can be reduced to  $-4879$ . Then,

$$|M_{YSA}/M_{YST4}| = | -4879/2440 | = 1.999 < 2.00$$

For the DN 200 top discharge nozzle:

$$|F_{XDA}/F_{XDT4}| = | +7117/3780 | = 1.88 < 2.00$$

$$|F_{YDA}/F_{YDT4}| = | -445/3110 | = 0.14 < 2.00$$

$$|F_{ZDA}/F_{ZDT4}| = | +8674/4890 | = 1.77 < 2.00$$

$$|M_{XDA}/M_{XDT4}| = | +678/3530 | = 0.19 < 2.00$$

$$|M_{YDA}/M_{YDT4}| = | -3390/1760 | = 1.93 < 2.00$$

$$|M_{ZDA}/M_{ZDT4}| = | -4882/2580 | = 1.89 < 2.00$$

Provided that  $M_{YSA}$  can be reduced to  $-4879$ , the applied piping loads acting on each nozzle satisfy the condition specified in F.1.2 a).

<sup>15</sup> These sample problems are merely examples for illustration purposes only. [Each company shall develop its own approach.] They are not to be considered exclusive or exhaustive in nature. API makes no warranties, express or implied for reliance on or any omissions from the information contained in this document.

**Table F.1—Nozzle Sizes and Location Coordinates for Example 1A**

Nozzle	Size DN	x mm	y mm	z mm
Suction	250	+267	0	0
Discharge	200	0	-311	+381

**Table F.2—Applied Nozzle Loadings for Example 1A**

Force	Value N	Moment	Value N·m
—	—	Suction	—
$F_{XSA}$	+12,900	$M_{XSA}$	-1356
$F_{YSA}$	0	$M_{YSA}$	-5017 <sup>a</sup>
$F_{ZSA}$	-8852	$M_{ZSA}$	-7458
—	—	Discharge	—
$F_{XDA}$	+7117	$M_{XDA}$	+678
$F_{YDA}$	-445	$M_{YDA}$	-3390
$F_{ZDA}$	+8674	$M_{ZDA}$	-4882

<sup>a</sup> See F.4.1.2.1.

**F.4.1.2.2** A check of condition F.1.2 b) is as follows.

For the suction nozzle,  $F_{RSA}$  and  $M_{RSA}$  are determined using the square root of the sum of the squares method:

$$F_{RSA} = [(F_{XSA})^2 + (F_{YSA})^2 + (F_{ZSA})^2]^{0.5} = [(+12,900)^2 + (0)^2 + (-8852)^2]^{0.5} = 15,645$$

$$M_{RSA} = [(M_{XSA})^2 + (M_{YSA})^2 + (M_{ZSA})^2]^{0.5} = [(-1356)^2 + (-4879)^2 + (-7458)^2]^{0.5} = 9015$$

Referring to Equation (F.1):

$$\begin{aligned} F_{RSA}/(1.5 \times F_{RST4}) + M_{RSA}/(1.5 \times M_{RST4}) &\leq 2 \\ 15,645/(1.5 \times 9630) + 9015/(1.5 \times 6750) &\leq 2 \\ 1.96 &< 2 \end{aligned}$$

For the discharge nozzle,  $F_{RDA}$  and  $M_{RDA}$  are determined by the same method used to find  $F_{RSA}$  and  $M_{RSA}$ :

$$F_{RDA} = [(F_{XDA})^2 + (F_{YDA})^2 + (F_{ZDA})^2]^{0.5} = [(+7117)^2 + (-445)^2 + (+8674)^2]^{0.5} = 11,229$$

$$M_{RDA} = [(M_{XDA})^2 + (M_{YDA})^2 + (M_{ZDA})^2]^{0.5} = [(+678)^2 + (-3390)^2 + (-4882)^2]^{0.5} = 5982$$

Referring to Equation (F.2):

$$\begin{aligned} F_{RDA}/(1.5 \times F_{RDT4}) + M_{RDA}/(1.5 \times M_{RDT4}) &\leq 2 \\ 11,229/(1.5 \times 6920) + 5982/(1.5 \times 4710) &\leq 2 \\ 1.93 &< 2 \end{aligned}$$

The loads acting on each nozzle satisfy the appropriate interaction equation, so the condition specified in F.1.2 b) is satisfied.

**F.4.1.2.3** A check of condition F.1.2 c) is as follows.

To check this condition, the applied component forces and moments are translated and resolved to the center of the pump.  $F_{RCA}$  is determined as follows [see F.1.2 c)]:

$$F_{XCA} = F_{XSA} + F_{XDA}$$

$$F_{YCA} = F_{YSA} + F_{YDA}$$

$$F_{ZCA} = F_{ZSA} + F_{ZDA}$$

$$F_{RCA} = [(F_{XCA})^2 + (F_{YCA})^2 + (F_{ZCA})^2]^{0.5}$$

$$F_{XCA} = (+12,900) + (+7117) = +20,017$$

$$F_{YCA} = (0) + (-445) = -445$$

$$F_{ZCA} = (-8852) + (+8674) = -178$$

$$F_{RCA} = [(+20,017)^2 + (-445)^2 + (-178)^2]^{0.5} = 20,023$$

Referring to Equation (F.3):

$$F_{RCA} < 1.5 \times (F_{RST4} + F_{RDT4})$$

$$20,023 < 1.5 \times (9630 + 6920)$$

$$20,023 < 24,825$$

$M_{YCA}$  is determined as follows [see F.1.2 c)]:

$$\begin{aligned} M_{YCA} &= M_{YSA} + M_{YDA} + [(F_{XSA})(zS) + (F_{XDA})(zD) - (F_{ZSA})(xS) - (F_{ZDA})(xD)]/1000 \\ &= (-4879) + (-3390) + [(+12,900)(0.00) + \dots \\ &\quad \dots + (+7117)(+381) - (-8852)(+267) - (+8674)(0.00)]/1000 \\ &= -3194 \end{aligned}$$

Referring to Equation (F.4):

$$|M_{YCA}| < 2.0(M_{YST4} + M_{YDT4})$$

$$|-3194| < 2.0(2440 + 1760)$$

$$3194 < 8400$$

$M_{RCA}$  is determined as follows [see F.1.2 c)].

$$M_{XCA} = M_{XSA} + M_{XDA} - [(F_{YSA})(zS) + (F_{YDA})(zD) - (F_{ZSA})(yS) - (F_{ZDA})(yD)]/1000$$

$$M_{YCA} = M_{YSA} + M_{YDA} + [(F_{XSA})(zS) + (F_{XDA})(zD) - (F_{ZSA})(xS) - (F_{ZDA})(xD)]/1000$$

$$M_{ZCA} = M_{ZSA} + M_{ZDA} - [(F_{XSA})(yS) + (F_{XDA})(yD) - (F_{YSA})(xS) - (F_{YDA})(xD)]/1000$$

$$M_{RCA} = [(M_{XCA})^2 + (M_{YCA})^2 + (M_{ZCA})^2]^{0.5}$$

$$M_{XCA} = (-1356) + (+678) - [(0)(0.00) + (-445)(+381) - (-8852)(0.00) - (+8674)(-311)]/1000$$

$$= -3206$$

$$M_{YCA} = -3194 \text{ (see previous calculation)}$$

$$M_{ZCA} = (-7458) + (-4882) - [(+12,900)(0.00) + (+7117)(-311) - (0)(+267) - (-445)(0.00)]/1000$$

$$= -10,127$$

$$M_{RCA} = [(-3206)^2 + (-3194)^2 + (-10,127)^2]^{0.5}$$

$$= 11,092$$

Referring to Equation (F.5):

$$M_{RCA} < 1.5 \times (M_{RST4} + M_{RDT4})$$

$$11,092 < 1.5 \times (6750 + 4710)$$

$$11,092 < 17,190$$

Thus, all the requirements of F.1.2 c) have been satisfied.

## F.4.2 Example 2A—SI Units

### F.4.2.1 Problem

For a DN 80 × DN 100 × 178 mm vertical in-line pump (OH3 or OH6), the proposed applied nozzle loadings are as given in Table F.3. By inspection,  $F_{ZSA}$ ,  $M_{ZSA}$ , and  $M_{XDA}$  are greater than two times the values shown in Table 5 (SI units). As stated in F.2, these component loads are acceptable provided that the calculated principal stress is less than 41 MPa. The problem is to determine the principal stress for the suction nozzle and the discharge nozzle.

**Table F.3—Proposed Applied Nozzle Loadings for Example 2A**

Force	Value N	Moment	Value N·m
—	—	DN 100 suction	—
$F_{XSA}$	-2224	$M_{XSA}$	+136
$F_{YSA}$	-5338	$M_{YSA}$	-2034
$F_{ZSA}$	+1334	$M_{ZSA}$	+1356
—	—	DN 80 discharge	—
$F_{XDA}$	+1334	$M_{XDA}$	+2712
$F_{YDA}$	-2224	$M_{YDA}$	+271
$F_{ZDA}$	+445	$M_{ZDA}$	+136

### F.4.2.2 Solution

#### F.4.2.2.1 Suction nozzle calculations are as follows.

For Schedule 40 pipe with a nominal size of DN 100,  $D_o = 114$  mm and  $D_i = 102$  mm. Therefore,

$$D_o^2 - D_i^2 = (114)^2 - (102)^2 = 2592$$

$$D_o^4 - D_i^4 = (114)^4 - (102)^4 = 6.065 \times 10^7$$

$$[(F_{XSA})^2 + (F_{ZSA})^2]^{0.5} = [(-2224)^2 + (+1334)^2]^{0.5} = 2593$$

$$[(M_{XSA})^2 + (M_{ZSA})^2]^{0.5} = [(+136)^2 + (+1356)^2]^{0.5} = 1363$$

Equation (F.7) is used to determine the longitudinal stress for the suction nozzle,  $\sigma_s$ .

The applied  $F_{YSA}$  load acting on the suction nozzle is in the negative Y direction and produces a compressive stress; therefore, the negative sign on  $F_{YSA}$  is used.

$$\begin{aligned}\sigma_s &= [1.27F_{YSA}/(D_o^2 - D_i^2)] + [10,200D_o(M_{XSA}^2 + M_{ZSA}^2)^{0.5}/(D_o^4 - D_i^4)] \\ &= [1.27(-5338)/2592] + [10,200 \times 114 \times 1363/(6.065 \times 10^7)] = 23.52\end{aligned}$$

Equation (F.8) is used to determine the shear stress for the suction nozzle,  $\tau_s$ .

$$\begin{aligned}\tau_s &= [1.27(F_{XSA})^2 + (F_{ZSA})^2]^{0.5}/(D_o^2 - D_i^2) + [0.51 \times 10^4 D_o (|M_{YSA}|)]/(D_o^4 - D_i^4) \\ &= (1.27 \times 2593/2592) + [5100 \times 114 \times (|-2034|)]/(6.065 \times 10^7) = 20.77\end{aligned}$$

The principal stress for the suction nozzle,  $\sigma_{p,s}$ , is calculated using Equation (F.6):

$$\begin{aligned}\sigma_{p,s} &= (\sigma_s/2) + (\sigma_s^2/4 + \tau_s^2)^{0.5} < 41 \\ &= (+23.52/2) + [(+23.52)^2/4 + (+20.77)^2]^{0.5} < 41 \\ &= +35.63 < 41\end{aligned}$$

Thus, the suction nozzle loads are satisfactory.

#### F.4.2.2.2 Discharge nozzle calculations are as follows:

For Schedule 40 pipe with a nominal size of 80 mm,  $D_o = 89$  mm and  $D_i = 78$  mm. Therefore,

$$D_o^2 - D_i^2 = (89)^2 - (78)^2 = 1837$$

$$D_o^4 - D_i^4 = (89)^4 - (78)^4 = 2.573 \times 10^7$$

$$[(F_{XDA})^2 + (F_{ZDA})^2]^{0.5} = [(+1334)^2 + (+445)^2]^{0.5} = 1406$$

$$[(M_{XDA})^2 + (M_{ZDA})^2]^{0.5} = [(+2712)^2 + (+136)^2]^{0.5} = 2715$$

Equation (F.7) is used to determine the longitudinal stress for the discharge nozzle,  $\sigma_D$ .

The applied  $F_{YDA}$  load acting on the discharge nozzle is in the negative Y direction and produces a tensile stress; therefore, a positive sign on  $F_{YDA}$  is used.

$$\begin{aligned}\sigma_D &= [1.27F_{YDA}/(D_o^2 - D_i^2)] + [10,200D_o(M_{XDA}^2 + M_{ZDA}^2)^{0.5}]/(D_o^4 - D_i^4) \\ &= [1.27(+2224)/1837] + [10,200(89)(2715)]/2.573 \times 10^7 = 97.33\end{aligned}$$

Equation (F.8) is used to determine the shear stress for the discharge nozzle,  $\tau_D$ .

$$\begin{aligned}\tau_D &= [1.27(F_{XDA}^2 + F_{ZDA}^2)^{0.5}/(D_o^2 - D_i^2) + [5100D_o(|M_{YDA}|)]/(D_o^4 - D_i^4) \\ &= [1.27 \times 1406/1837] + [5100 \times 89 \times (|+271|)]/(2.573 \times 10^7) = 5.75\end{aligned}$$

The principal stress for the discharge nozzle,  $\sigma_{p,D}$ , is calculated using Equation (F.6):

$$\begin{aligned}\sigma_{p,D} &= (\sigma_D/2) + (\sigma_D^2/4 + \tau_D^2)^{0.5} < 41 \\ &= (+97.33/2) + [(+97.33)^2/4 + (+5.75)^2]^{0.5} \\ &= +97.67 > 41\end{aligned}$$

Thus, the discharge nozzle loads are too large. By inspection, if  $M_{XDA}$  is reduced by 50 % to 1356 N·m, the resulting principal stress still exceeds 41 MPa. Therefore, the maximum value for  $M_{XDA}$  is twice  $M_{XDT4}$ , or 1900 N·m.

### F.4.3 Example 1B—USC Units

#### F.4.3.1 Problem

For an overhung end-suction process pump (OH2), the nozzle sizes and location coordinates are as given in Table F.4. The applied nozzle loadings are as given in Table F.5. The problem is to determine whether the conditions specified in F.1.2 a), F.1.2 b), and F.1.2 c) are satisfied.

**Table F.4—Nozzle Sizes and Location Coordinates for Example 1B**

Dimensions in inches

Nozzle	Size	x	y	z
Suction	10	+10.50	0	0
Discharge	8	0	-12.25	+15



**Table F.5—Applied Nozzle Loadings for Example 1B**

Force	Value lbf	Moment	Value ft·lbf
—	—	Suction	—
$F_{XSA}$	+2900	$M_{XSA}$	-1000
$F_{YSA}$	0	$M_{YSA}$	-3700 <sup>a</sup>
$F_{ZSA}$	-1990	$M_{ZSA}$	-5500
—	—	Discharge	—
$F_{XDA}$	+1600	$M_{XDA}$	+500
$F_{YDA}$	-100	$M_{YDA}$	-2500
$F_{ZDA}$	+1950	$M_{ZDA}$	-3600

<sup>a</sup> See F.4.1.2.1.

**F.4.3.2 Solution**

**F.4.3.2.1** A check of condition of F.1.2 a) is as follows:

For the 10 in. end suction nozzle:

$$|F_{XSA}/F_{XST4}| = |2900/1500| = 1.93 < 2.00$$

$$|F_{YSA}/F_{YST4}| = |0/1200| = 0 < 2.00$$

$$|F_{ZSA}/F_{ZST4}| = |-1990/1000| = 1.99 < 2.00$$

$$|M_{XSA}/M_{XST4}| = |-1000/3700| = 0.27 < 2.00$$

$$|M_{YSA}/M_{YST4}| = |-3700/1800| = 2.06 > 2.00$$

$$|M_{ZSA}/M_{ZST4}| = |-5500/2800| = 1.96 < 2.00$$

Since  $M_{YSA}$  exceeds the value specified in Table 5 (USC units) by more than a factor of 2, it is not satisfactory. Assume that  $M_{YSA}$  can be reduced to -3599. Then,

$$|M_{YSA}/M_{YST4}| = |-3599/1800| = 1.999 < 2.00$$

For the 8 in. top discharge nozzle:

$$|F_{XDA}/F_{XDT}| = |1600/850| = 1.88 < 2.00$$

$$|F_{YDA}/F_{YDT}| = |-100/700| = 0.14 < 2.00$$

$$|F_{ZDA}/F_{ZDT4}| = |1950/1100| = 1.77 < 2.00$$

$$|M_{XDA}/M_{XDT4}| = |500/2600| = 0.19 < 2.00$$

$$|M_{YDA}/M_{YDT4}| = |-2500/1300| = 1.93 < 2.00$$

$$|M_{ZDA}/M_{ZDT4}| = |-3600/1900| = 1.89 < 2.00$$

Provided that  $M_{YSA}$  can be reduced to  $-3599$ , the applied piping loads acting on each nozzle satisfy the condition specified in F.1.2 a).

**F.4.3.2.2** A check of condition F.1.2 b) is as follows:

For the suction nozzle,  $F_{RSA}$  and  $M_{RSA}$  are determined using the square root of the sum of the squares method:

$$F_{RSA} = [(F_{XSA})^2 + (F_{YSA})^2 + (F_{ZSA})^2]^{0.5} = [(+2900)^2 + (0)^2 + (-1990)^2]^{0.5} = 3517$$

$$M_{RSA} = [(M_{XSA})^2 + (M_{YSA})^2 + (M_{ZSA})^2]^{0.5} = [(-1000)^2 + (-3599)^2 + (-5500)^2]^{0.5} = 6649$$

Referring to Equation (F.1),

$$F_{RSA}/(1.5 \times F_{RST4}) + M_{RSA}/(1.5 \times M_{RST4}) < 2$$

$$3517/(1.5 \times 2200) + 6649/(1.5 \times 5000) < 2$$

$$1.95 < 2$$

For the discharge nozzle,  $F_{RDA}$  and  $M_{RDA}$  are determined by the same method used to find  $F_{RSA}$  and  $M_{RSA}$ :

$$F_{RDA} = [(F_{XDA})^2 + (F_{YDA})^2 + (F_{ZDA})^2]^{0.5} = [(+1600)^2 + (-100)^2 + (+1950)^2]^{0.5} = 2524$$

$$M_{RDA} = [(M_{XDA})^2 + (M_{YDA})^2 + (M_{ZDA})^2]^{0.5} = [(+500)^2 + (-2500)^2 + (-3600)^2]^{0.5} = 4411$$

Referring to Equation (F.2),

$$F_{RDA}/(1.5 \times F_{RDT4}) + M_{RDA}/(1.5 \times M_{RDT4}) < 2$$

$$2524/(1.5 \times 1560) + 4411/(1.5 \times 3500) < 2$$

$$1.92 < 2$$

The loads acting on each nozzle satisfy the appropriate interaction equation, so the condition specified in F.1.2 b) is satisfied.

**F.4.3.2.3** A check of condition F.1.2 c) is as follows.

To check this condition, the applied component forces and moments are translated and resolved to the center of the pump.  $F_{RCA}$  is determined as follows [see F.1.2 c)]:

$$F_{XCA} = F_{XSA} + F_{XDA}$$

$$F_{YCA} = F_{YSA} + F_{YDA}$$

$$F_{ZCA} = F_{ZSA} + F_{ZDA}$$

$$F_{RCA} = [(F_{XCA})^2 + (F_{YCA})^2 + (F_{ZCA})^2]^{0.5}$$

$$F_{XCA} = (+2900) + (+1600) = +4500$$

$$F_{YCA} = (0) + (-100) = -100$$

$$F_{ZCA} = (-1990) + (+1950) = -40$$

$$F_{RCA} = [(+4500)^2 + (-100)^2 + (-40)^2]^{0.5} = 4501$$

Referring to Equation (F.3),

$$F_{RCA} < 1.5 \times (F_{RST4} + F_{RDT4})$$

$$4501 < 1.5 \times (2200 + 1560)$$

$$4501 < 5640$$

$M_{YCA}$  is determined as follows [see F.1.2 c):

$$\begin{aligned} M_{YCA} &= M_{YSA} + M_{YDA} + [(F_{XSA})(zS) + (F_{XDA})(zD) - (F_{ZSA})(xS) - (F_{ZDA})(xD)]/12 \\ &= (-3599) + (-2500) + [(+2900)(0.00) + (+1600)(+15) - (-1990)(+10.5) - (+1950)(0.00)]/12 \\ &= -2358 \end{aligned}$$

Referring to Equation (F.4),

$$|M_{YCA}| < 2.0 \times (M_{YST4} + M_{YDT4})$$

$$|-2358| < 2.0 \times (1800 + 1300)$$

$$2358 < 6200$$

$M_{RCA}$  is determined as follows [see F.1.2 c):

$$M_{XCA} = M_{XSA} + M_{XDA} - [(F_{YSA})(zS) + (F_{YDA})(zD) - (F_{ZSA})(yS) - (F_{ZDA})(yD)]/12$$

$$M_{YCA} = M_{YSA} + M_{YDA} + [(F_{XSA})(zS) + (F_{XDA})(zD) - (F_{ZSA})(xS) - (F_{ZDA})(xD)]/12$$

$$M_{ZCA} = M_{ZSA} + M_{ZDA} - [(F_{XSA})(yS) + (F_{XDA})(yD) - (F_{YSA})(xS) - (F_{YDA})(xD)]/12$$

$$M_{RCA} = [(M_{XCA})^2 + (M_{YCA})^2 + (M_{ZCA})^2]^{0.5}$$

$$\begin{aligned} M_{XCA} &= (-1000) + (+500) - [(0)(0.00) + (-100)(+15.00) - (-1990)(0.00) - (+1950)(-12.25)]/12 \\ &= -2366 \end{aligned}$$

$$M_{YCA} = -2358 \text{ (see previous calculation)}$$

$$\begin{aligned} M_{ZCA} &= (-5500) + (-3600) - [(+2900)(0.00) + (+1600)(-12.25) - (0)(+10.50) - (-100)(0.00)]/12 \\ &= -7467 \end{aligned}$$

$$M_{RCA} = [(-2366)^2 + (-2358)^2 + (-7467)^2]^{0.5} = 8180$$

Referring to Equation (F.5),

$$M_{RCA} < 1.5 \times (M_{RST4} + M_{RDT4})$$

$$8180 < 1.5 \times (5000 + 3500)$$

$$8180 < 12,750$$

Thus, all the requirements of F.1.2 c) have been satisfied.

## F.4.4 Example 2B—USC Units

### F.4.4.1 Problem

For a NPS 3 × NPS 4 × 7 in. vertical in-line pump (OH3 or OH6), the proposed applied nozzle loadings are as given in Table F.6. By inspection,  $F_{ZSA}$ ,  $M_{ZSA}$ , and  $M_{XDA}$  are greater than two times the values shown in Table 5 (USC units). As stated in F.2, these component loads are acceptable provided that the calculated principal stress is less than 5950 psi. The problem is to determine the principal stress for the suction nozzle and the discharge nozzle.

**Table F.6—Proposed Applied Nozzle Loadings for Example 2B**

Force	Value lbf	Moment	Value ft·lbf
—	—	NPS 4 suction	—
$F_{XSA}$	-500	$M_{XSA}$	+100
$F_{YSA}$	-1200	$M_{YSA}$	-1500
$F_{ZSA}$	+300	$M_{ZSA}$	+1000
—	—	NPS 3 discharge	—
$F_{XDA}$	+300	$M_{XDA}$	+2000
$F_{YDA}$	-500	$M_{YDA}$	+200
$F_{ZDA}$	+100	$M_{ZDA}$	+100

### F.4.4.2 Solution

#### F.4.4.2.1 Suction nozzle calculations are as follows.

For Schedule 40 pipe with a nominal size of 4 in.,  $D_o = 4.500$  in. and  $D_i = 4.026$  in. Therefore,

$$D_o^2 - D_i^2 = (4.500)^2 - (4.026)^2 = 4.04$$

$$D_o^4 - D_i^4 = (4.500)^4 - (4.026)^4 = 147.34$$

$$[(F_{XSA})^2 + (F_{ZSA})^2]^{0.5} = [(-500)^2 + (+300)^2]^{0.5} = 583$$

$$[(M_{XSA})^2 + (M_{ZSA})^2]^{0.5} = [(+100)^2 + (+1000)^2]^{0.5} = 1005$$

Equation (F.10) is used to determine the longitudinal stress for the suction nozzle,  $\sigma_{l,s}$ .

The applied  $F_{YSA}$  load acting on the suction nozzle is in the negative Y direction and produces a compressive stress; therefore, the negative sign on  $F_{YSA}$  is used.

$$\begin{aligned} \sigma_{l,s} &= [1.27F_{YSA}/(D_o^2 - D_i^2)] + [122D_o(M_{XSA}^2 + M_{ZSA}^2)^{0.5}]/(D_o^4 - D_i^4) \\ &= [1.27 \times (-1200)/4.04] + [122 \times 4.500 \times 1005]/147.34 \\ &= 3367 \end{aligned}$$

Equation (F.11) is used to determine the shear stress for the suction nozzle,  $\tau_s$ .

$$\begin{aligned} \tau_s &= [1.27(F_{XSA}^2 + F_{ZSA}^2)^{0.5}]/(D_o^2 - D_i^2) + [61D_o(|M_{YSA}|)]/(D_o^4 - D_i^4) \\ &= (1.27 \times 583/4.04) + [61 \times 4500(|-1500|)]/147.34 \\ &= 2978 \end{aligned}$$

The principal stress for the suction nozzle,  $\sigma_{p,s}$ , is calculated using Equation (F.9):

$$\begin{aligned}\sigma_{p,s} &= (\sigma_s/2) + (\sigma_s^2/4 + \tau_s^2)^{0.5} < 5950 \\ &= (+3367/2) + [(+3367)^2/4 + (+2978)^2]^{0.5} \\ &= +5105 < 950\end{aligned}$$

Thus, the suction nozzle loads are satisfactory.

#### F.4.4.2.2 Discharge nozzle calculations are as follows.

For Schedule 40 pipe with a nominal size of 3 in.,  $D_o = 3.500$ , and  $D_i = 3.068$ . Therefore,

$$\begin{aligned}D_o^2 - D_i^2 &= (3.500)^2 - (3.068)^2 = 2.84 \\ D_o^4 - D_i^4 &= (3.500)^4 - (3.068)^4 = 61.47 \\ [(F_{XDA})^2 + (F_{ZDA})^2]^{0.5} &= [(+300)^2 + (+100)^2]^{0.5} = 316 \\ [(M_{XDA})^2 + (M_{ZDA})^2]^{0.5} &= [(+2000)^2 + (+100)^2]^{0.5} = 2002\end{aligned}$$

Equation (F.10) is used to determine the longitudinal stress for the discharge nozzle,  $\sigma_{l,D}$ .

The applied  $F_{YDA}$  load acting on the discharge nozzle is in the negative Y direction and produces a tensile stress; therefore, a positive sign on  $F_{YDA}$  is used.

$$\begin{aligned}\sigma_{l,D} &= [1.27F_{YDA}/(D_o^2 - D_i^2)] + [122D_o(M_{XDA}^2 + M_{ZDA}^2)^{0.5}]/(D_o^4 - D_i^4) \\ &= [12.7(+500)/2.84] + [122(3.5)(2002)]/61.47 \\ &= 14,131\end{aligned}$$

Equation (F.11) is used to determine the shear stress for the discharge nozzle,  $\tau_D$ .

$$\begin{aligned}\tau_D &= [1.27(F_{XDA}^2 + F_{ZDA}^2)^{0.5}]/(D_o^2 - D_i^2) + [61D_o(|M_{YDA}|)]/(D_o^4 - D_i^4) \\ &= (1.27 \times 316/2.84) + [61 \times 3.500 \times (|+200|)]/61.47 = 836\end{aligned}$$

The principal stress for the discharge nozzle,  $\sigma_{p,D}$ , is calculated using Equation (F.9):

$$\begin{aligned}\sigma_{p,D} &= (\sigma_D/2) + (\sigma_D^2/4 + \tau_D^2)^{0.5} < 5950 \\ &= (+14,131/2) + [(+14,131)^2/4 + (+836)^2]^{0.5} = +14,181 > 5950\end{aligned}$$

Thus, the discharge nozzle loads are too large. By inspection, if  $M_{XDA}$  is reduced by 50 % to 1000 ft·lbf, the resulting principal stress still exceeds 5950 psi. Therefore, the maximum value for  $M_{XDA}$  is twice  $M_{XDT4}$ , or 1400 ft·lbf.

## Annex G (informative)

### Materials Class Selection Guidance

Table G.1 is intended to provide general guidance for on-plot process plants and off-plot transfer and loading services. It should not be used without a knowledgeable review of the specific services involved.

**Table G.1—Materials Class Selection Guidance**

Service	Temperature Range		Pressure Range	Materials Class	Ref. Note
	°F	°C			
Fresh water, condensate, cooling tower water (pH > 6)	< 200	< 93	All	S-5	—
Process water (pH > 6)	< 200	< 93	All	S-5 or S-6	a
Boiling water and boiler feedwater (pH > 6)	> 200	> 93	All	S-6 or C-6	a
Boiler circulator (pH > 6)	> 200	> 93	All	C-6	—
Foul water, reflux drum water, water draw, and hydrocarbons containing these waters, including reflux streams	< 350	< 175	All	S-8 or S-6	b
	> 350	> 175	All	C-6	—
Propane, butane, liquefied petroleum gas, ammonia, ethylene, low-temperature services (minimum metal temperature)	< 450	230	All	S-4	—
	> -50	> -46	All	S-4 LCB	h
	> -100	> -73	All	S-4 LC2	h
	> -150	> -100	All	S-4 LC3	h i
	> -320	> -196	All	A-7 or A-8	h i
Diesel oil; gasoline; naphtha; kerosene; gas oils; light, medium and heavy lubricating oils; fuel oil; residuum; crude oil; asphalt; synthetic crude bottoms	< 450	< 230	All	S-4	—
	450 to 700	230 to 370	All	S-6	b c
	> 700	> 370	All	C-6	b
Noncorrosive hydrocarbons, e.g. catalytic reformat, isomaxate, desulfurized oils	450 to 700	230 to 370	All	S-4	c
Xylene, toluene, acetone, benzene, furfural, methylethylketone (MEK), cumene	< 450	< 230	All	S-4	—
Sodium carbonate	< 350	< 175	All	C-6	—
Caustic (sodium hydroxide), concentration < 20 %	< 212	< 100	All	S-4	d
	> 212	> 100	All	—	e
Seawater	< 200	< 95	All	A-8, D-1, or D-2	f
Sour water	< 500	< 260	All	D-1	—
Produced water, formation water, and brine	All	All	All	A-8, D-1, or D-2	f
Sulfur (liquid state)	All	All	All	S-4	—
Fluid catalytic cracker (FCC) slurry	< 700	< 370	All	C-6	j

**Table G.1—Materials Class Selection Guidance (Continued)**

Service	Temperature Range		Pressure Range	Materials Class	Ref. Note
	°F	°C			
Potassium carbonate	< 350	< 175	All	C-6	—
	< 700	< 370	All	A-8	—
MEA (monoethylamine), diethylamine (DEA), triethylamine (TEA) stock solutions	< 250	< 120	All	S-4	—
DEA, TEA-lean solutions	< 250	< 120	All	S-4 or S-8	d g
MEA-lean solution (CO <sub>2</sub> only)	175 to 300	80 to 150	All	S-9	d
MEA-lean solution (CO <sub>2</sub> and H <sub>2</sub> S)	175 to 300	80 to 150	All	S-8	d g
MEA-, DEA-, TEA-rich solutions	175	< 80	All	S-4 or S-8	d
Sulfuric acid concentration > 85 % 85 % to < 1 %	< 100	< 38	All	S-4	b
	< 450	< 230	All	A-8	b
Hydrofluoric acid concentration > 96 %	< 100	< 38	All	S-9	b
<p>The materials for pump parts for each material class are given in Annex H.</p> <p>Specific materials recommendations shall be obtained for services not clearly identified by the service descriptions listed in this table.</p>					
<p><sup>a</sup> The pH, conductivity, and dissolved oxygen content of the water shall be considered in the final material selection. High-purity water requires steels with some chrome alloying to avoid erosion corrosion in high-velocity areas.</p> <p><sup>b</sup> The corrosiveness of foul waters, hydrocarbons over 450 °F (230 °C), acids, and acid sludge may vary widely. Material recommendations shall be obtained for each service. The material class indicated above is satisfactory for many of these services, but shall be verified. S-8 materials may also be considered for operating temperatures below 150 °F (66 °C).</p> <p><sup>c</sup> If product corrosivity is low, Class S-4 materials may be used for services at 451 °F to 700 °F (231 °C to 370 °C). Specific material recommendations shall be obtained in each instance.</p> <p><sup>d</sup> All welds shall be stress-relieved.</p> <p><sup>e</sup> UNS N08007 or Ni-Cu alloy pump material shall be used.</p> <p><sup>f</sup> For seawater, produced water, formation water, and brine services, the purchaser and the vendor shall agree on the construction materials that best suit the intended use.</p> <p><sup>g</sup> The vendor shall consider the effects of differential material expansion between casing and rotor and confirm suitability if operating temperatures can exceed 200 °F (95 °C).</p> <p><sup>h</sup> Materials selected for low-temperature services shall meet the requirements of 6.12.4. Casting alloy Grades LCB, LC2, and LC3 are shown only for reference. Grades LCB, LC2, and LC3 refer to ISO 4991. C23-45BL, C43E2aL, and C43L are equivalent to ASTM A352/A352M, Grades LCB, LC2, and LC3. Use equivalent materials for wrought alloys.</p> <p><sup>i</sup> Material alloys based on aluminum, bronze, aluminum bronze, and nickel, may also be considered for temperatures as low as -320 °F (-196 °C).</p> <p><sup>j</sup> Due to the abrasive nature of FCC slurry services, additional hard coating of wearing surfaces may be considered to increase the life of the part. Lined pumps may also be considered to increase life of the part.</p>					

## **Annex H** (normative)

### **Materials and Material Specifications for Pump Parts**

Table H.1 lists material classes for the purchaser to select (see 6.12.1.3).

Table H.2, Table H.3, and Table H.4 may be used for guidance regarding materials specifications. If these tables are used, it should not be assumed that the material specifications are acceptable without taking full account of the service in which they will be applied. Table H.2 lists corresponding materials that may be considered acceptable. These materials represent family/type and grade only. The final required condition or hardness level (where appropriate) is not specified. These materials might not be interchangeable for all applications.



**Table H.1—Material Classes for Pump Parts**

Part	Material Classes and Abbreviations										
	Material Class	S-4 <sup>k</sup>	S-5 <sup>k</sup>	S-6 <sup>f k</sup>	S-8 <sup>k</sup>	S-9 <sup>k</sup>	C-6	A-7	A-8	D-1 <sup>i</sup>	D-2 <sup>i</sup>
	Full Compliance Material <sup>a b</sup>	STL	STL	STL	STL	STL	12 % CR	AUS	316 AUS	Duplex	Super Duplex
	Trim Material <sup>a b</sup>	STL	STL 12 % CR	12 % CR	316 AUS	Ni-Cu Alloy	12 % CR	AUS <sup>c d</sup>	316 AUS <sup>d</sup>	Duplex	Super Duplex
Pressure casing	Yes	Carbon steel	Carbon steel	Carbon steel	Carbon steel	Carbon steel	12 % CR	AUS	316 AUS	Duplex	Super duplex
Inner case parts (bowls, diffusers, diaphragms)	No	Carbon steel	Carbon steel	12 % CR	316 AUS	Ni-Cu alloy	12 % CR	AUS	316 AUS	Duplex	Super duplex
Impeller	Yes	Carbon steel	Carbon steel	12 % CR	316 AUS	Ni-Cu alloy	12 % CR	AUS	316 AUS	Duplex	Super duplex
Case wear rings <sup>j</sup>	No	Cast iron	12 % CR hardened	12 % CR hardened	Hard-faced 316 AUS <sup>e</sup>	Ni-Cu alloy	12 % CR hardened	Hard-faced AUS <sup>e</sup>	Hard-faced 316 AUS <sup>e</sup>	Hard-faced duplex <sup>e</sup>	Hard-faced super duplex <sup>e</sup>
Impeller wear rings <sup>j</sup>	No	Cast iron	12 % CR hardened	12 % CR hardened	Hard-faced 316 AUS <sup>e</sup>	Ni-Cu alloy	12 % CR hardened	Hard-faced AUS <sup>e</sup>	Hard-faced 316 AUS <sup>e</sup>	Hard-faced duplex <sup>e</sup>	Hard-faced super duplex <sup>e</sup>
Shaft <sup>d</sup>	Yes	Carbon steel	4140 alloy steel	12 % CR	316 AUS	Ni-Cu alloy	12 % CR	AUS	316 AUS	Duplex	Super duplex
Throat bushings <sup>j</sup>	No	Cast iron	12 % CR hardened	12 % CR hardened	316 AUS	Ni-Cu alloy	12 % CR hardened	AUS	316 AUS	Duplex	Super duplex
Interstage sleeves <sup>j</sup>	No	Cast iron	12 % CR hardened	12 % CR hardened	Hard-faced 316 AUS <sup>e</sup>	Ni-Cu alloy	12 % CR hardened	Hard-faced AUS <sup>e</sup>	Hard-faced 316 AUS <sup>e</sup>	Hard-faced duplex <sup>e</sup>	Hard-faced super duplex <sup>e</sup>
Interstage bushings <sup>j</sup>	No	Cast iron	12 % CR hardened	12 % CR hardened	Hard-faced 316 AUS <sup>e</sup>	Ni-Cu alloy	12 % CR hardened	Hard-faced AUS <sup>e</sup>	Hard-faced 316 AUS <sup>e</sup>	Hard-faced duplex <sup>e</sup>	Hard-faced super duplex <sup>e</sup>
Case and gland studs	Yes	4140 alloy steel	4140 alloy steel	4140 alloy steel	4140 alloy steel	Ni-Cu alloy hardened <sup>i</sup>	4140 alloy steel	4140 alloy steel	4140 alloy steel	Duplex <sup>h</sup>	Super duplex <sup>h</sup>

Table H.1—Material Classes for Pump Parts (Continued)

Part	Material Classes and Abbreviations										
	Material Class	S-4 <sup>k</sup>	S-5 <sup>k</sup>	S-6 <sup>f k</sup>	S-8 <sup>k</sup>	S-9 <sup>k</sup>	C-6	A-7	A-8	D-1 <sup>i</sup>	D-2 <sup>i</sup>
	Full Compliance Material <sup>a b</sup>	STL	STL	STL	STL	STL	12 % CR	AUS	316 AUS	Duplex	Super Duplex
Trim Material <sup>a b</sup>	STL	STL 12 % CR	12 % CR	316 AUS	Ni-Cu Alloy	12 % CR	AUS <sup>c d</sup>	316 AUS <sup>d</sup>	Duplex	Super Duplex	
Case gasket	No	AUS, spiral-wound <sup>g</sup>	AUS, spiral-wound <sup>g</sup>	AUS, spiral-wound <sup>g</sup>	316 AUS spiral-wound <sup>g</sup>	Ni-Cu alloy, spiral-wound, PTFE filled <sup>g</sup>	AUS, spiral-wound <sup>g</sup>	AUS, spiral-wound <sup>g</sup>	316 AUS spiral-wound <sup>g</sup>	Duplex SS spiral-wound <sup>g</sup>	Duplex SS spiral-wound <sup>g</sup>
Discharge head/suction can	Yes	Carbon steel	Carbon steel	Carbon steel	Carbon steel	Carbon steel	AUS	AUS	316 AUS	Duplex	Super duplex
Column/bowl shaft bushings	No	Filled carbon	Filled carbon	Filled carbon	Filled carbon	Filled carbon	Filled carbon	Filled carbon	Filled carbon	Filled carbon	Filled carbon
Wetted fasteners (bolts)	Yes	Carbon steel	316 AUS <sup>l</sup>	316 AUS <sup>l</sup>	316 AUS	Ni-Cu alloy	316 AUS <sup>l</sup>	316 AUS	316 AUS	Duplex	Super duplex

<sup>a</sup> See 6.12.1.5.

<sup>b</sup> The abbreviations in the upper part of the second row indicate the case material; the abbreviations in the lower part of the second row indicate trim material. Abbreviations are as follows: 12 % CR, 12 % chromium; 316 AUS, austenitic stainless steel containing at least 2.0 % molybdenum; 4140 alloy steel, high-strength steels with approximately 0.40 % carbon, 1 % chromium, and 0.2 % molybdenum; AUS, austenitic stainless steel; CI, cast iron; STL, steel.

<sup>c</sup> Austenitic stainless steels include ISO types 683-13-10/19 (AISI standard types 302, 303, 304, 316, 321, and 347).

<sup>d</sup> For vertically suspended pumps with shafts exposed to liquid and running in bushings (Types VS1, VS2, VS3, VS4, VS6, and VS7), the standard shaft material for Classes S-4 and S-5 is 12 % chrome. The standard shaft material for cantilever pumps (Type VS5) is 4140 alloy steel where the service liquid allows (see Table G.1).

<sup>e</sup> Unless otherwise specified, the requirement for hard-facing and the specific hard-facing material for each application is determined by the vendor and described in the proposal. Alternatives to hard-facing may include opening running clearances (6.7.5) or the use of nongalling materials or nonmetallic materials, depending on the corrosiveness of the pumped liquid.

<sup>f</sup> For Types VS6 and VS7 pumps in pipeline services with maximum operating temperatures of 130 °F (55 °C) or less, carbon steel bowls in S-6 material column may be considered by the purchaser. The purchaser to note on data sheet (Annex N).

<sup>g</sup> If pumps with axially split casings are furnished, a sheet gasket suitable for the service is acceptable. Spiral-wound gaskets shall contain a filler material suitable for the service. Gaskets other than spiral-wound may be proposed and furnished if proven suitable for service and approved by the purchaser. See 6.3.12.

<sup>h</sup> Unless otherwise specified, AISI 4140 alloy steel may be used for nonwetted case and gland studs.

<sup>i</sup> Some applications may require alloy grades higher than the duplex materials given in Table H.2. "Super duplex" material grades with pitting resistance equivalency (PRE) values greater than 40 can be necessary.

PRE ≥ 40, where the PRE is based on actual chemical analysis.

PRE =  $w_{Cr} + 3.3w_{Mo} + 16w_{N}$ , where  $w$  is the percentage mass fraction of the element indicated by the subscript.

Note that alternative materials such as "super austenitic" may also be considered.

<sup>j</sup> Nonmetallic wear part materials, proven compatible with the specified process liquid, may be proposed within the applicable limits shown in Table H.3. [Also see 6.7.5 c)].

<sup>k</sup> The vendor shall consider the effects of differential material expansion between casing and rotor elements and confirm suitability if operating temperatures can exceed 200 °F (95 °C).

<sup>l</sup> For applications where large differences of thermal expansion can result if austenitic stainless steel fasteners are used, alternative fastener materials, such as 12 % or 17 % Cr martensitic steel, with appropriate corrosion resistance, may be used.

**Table H.2—Material Specifications for Pump Parts**

Material Class	Applications	ISO	USA		EN <sup>b</sup>	Europe		Japan JIS
			ASTM	UNS <sup>a</sup>		Grade	Material No.	
Cast iron	General castings	185 Gr 300	A48/A48M Class 25/30/40	F11701/F 12101	EN 1561	EN-GJL-250 EN-GJL-300	JL 1040JL 1050	G 5501 FC 250/300
Carbon steel	Wrought/ forgings	683-18-C25	A266 Class 4	K03506	EN 10222-2	P 280 GH	1.0426	G 3202, CI SFVC 2A
	Pressure castings	4991 C23-45 AH	A216/A216M Gr WCB	J03002	EN10213	GP 240 GH	1.0619	G 5151, CI SCPH 2
	Bar stock: pressure	683-18-C25	A696 Gr B	G10200	EN 10273	P 295 GH	1.0481	G 4051, CI S25C
	Bar stock: general	683-18-C45e	A576 Gr 1045	G10450	EN 10083-2	C 45	1.0503	G 4051, CI S45C
	Bolts and studs	2604-2-F31	A193/A193M Gr B7	G41400	EN 10269	42 Cr Mo 4	1.7225	G 4107, Class 2, SNB7
	Nuts	683-1-C45	A194/A194M Gr 2H	K04002	EN 10269	C 35 E	1.1181	G 4051, CI S45C
	Plate	9328-4, P 355 TN/ PL 355 TN	A516/A516M Gr 65/70	K02403/ K02700	EN 10028-3	P 355 N P 355 NL1	1.0562 1.0566	G 3106, Gr SM400B
	Pipe	9329-2 PH26	A106/A106M Gr B or C	K03006	EN 10208-1	L 245 GA	1.0459	G 3456, Gr STPT 370/410
Fittings	—	A105/A105M	K03504	—	—	—	G 4051 S25C G 3202 SFVC 2A G 3202 SFVC2B	
	—	A234/234M Gr WPB/WPC	K03006/K 03501	—	—	—		
4140 alloy steel	Bar stock	—	A434 Class BB A434 Class BC	G41400 <sup>c</sup>	EN 10083-1	42 Cr Mo 4	1.7225	G 4105, CI SCM 440
	Bolts and studs	2604-2-F31	A193/A193M Gr B7	G41400	EN 10269	42 Cr Mo 4	1.7225	G 4107, Class 2, SNB7
	Nuts	683-1-C45	A194/A194M Gr 2H	K04002	EN 10269	C 45 E	1.1191	G 4051, CI S45C
12 % chrome steel	Pressure castings	—	A487/A487M Gr CA6NM	J91540	EN 10283	GX 4 Cr Ni 13-4	1.4317	G 5121, CI SCS 6, SCS 6X
	Impellers and diffusers	—	A487/A487M Gr CA6NM	J91540	EN 10213	GX 4 Cr Ni 13-4	1.4317	G 5121, CI SCS 6 SCS 6X
		—	A743/A743M Gr CA6NM	J91540	EN 10213	GX 4 Cr Ni 13-4	1.4317	G 5121, CI SCS 6 SCS 6X
	General castings	—	A487/A487M Gr CA6NM	J91540	EN 10213	GX 4 Cr Ni 13-4	1.4317	G 5121, CI SCS 6 SCS 6X
		—	A743/A743M Gr CA6NM	J91540	EN 10283	GX 4 Cr Ni 13-4	1.4317	G 5121, CI SCS 6, SCS 6X
		—	A426/426M Gr CPCA15	J91150	EN 10283	GX12Cr12	1.4011	G5121 SCS1/SCS1X
Wrought/ forgings: pressure	683-13-3	A182/A182M Gr F6a Class 1 or 2	S41000	EN 10250-4 EN 10222-5	X12 Cr13	1.4006	G 3214, Gr SUS 410-A G 3214, CI SUS F6 NM	
	—	A182/A182M Gr F6 NM	S41500		X 3 Cr NiMo 13-4-1	1.4313		
Wrought/ forgings: general	683-13-2	A473 Type 410	S41000	EN 10088-3	X 12 Cr 13	1.4006	G 3214, Gr SUS 410-A	

**Table H.2—Material Specifications for Pump Parts (Continued)**

Material Class	Applications	ISO	USA		Europe			Japan
			ASTM	UNS <sup>a</sup>	EN <sup>b</sup>	Grade	Material No.	JIS
	Bar stock: pressure	683-13-3	A479/A479M Type 410	S41000	EN 10272	X12 Cr 13	1.4006	G 4303 Gr SUS 410 or 403
	Bar stock: general	683-13-3	A276 Type 410	S41000	EN 10088-3	X 12 Cr 13	1.4006	G 4303 Gr SUS 410 or 403
12 % chrome steel	Bar stock: forgings <sup>c</sup>	683-13-4	A276 Type 420 A473 Type 416 A582/A582M Type 416	S42000 S41600	EN 10088-3	X 20 Cr 13 X 20 Cr S 13 X 20 Cr S 13	1.4021 1.4005 1.4005	G 4303, Gr SUS 420J1 or 420J2
	Bolts and studs <sup>d</sup>	3506-1, C4-70	A193/A193M Gr B6	S41000	EN 10269	X22CrMo V 12-1	1.4923	G 4303 Gr SUS 410 or 403
	Nuts <sup>d</sup>	3506-2, C4-70	A194/A194M Gr 6	S41000	EN 10269	X22CrMo V 12-1	1.4923	G 4303 Gr SUS 410 or 403
	Plate	683-13-3	A240/A240M Type 410	S41000	EN 10088-2	X 12 Cr 13	1.4006	G 4304/4305 Gr SUS 403 or 410
	Pipe <sup>g</sup> ≤ 500 °F (260 °C) (316L)	683-13-10	B444 N06625 A312 Type 316L	N06625 S31603	EN 10095	NiCr22-M09NB	2.4856	G 3459 SUS316LTP
	Pipe <sup>g</sup> > 500 °F (260 °C) (N06625)	—	B444 N0625	N06625	EN 10095	N9Cr22-Mo9NB	2.4856	G 4903 NCF625TP
	Fittings <sup>g</sup> ≤ 500 °F (260 °C) (316L)	9327-5 X2CrNiMo 17-12	B446 N06625 A182 Gr 316L	N06625 S31603	EN 10088-2	NiCr22-M09NB	2.4856 1.4404	G 3214 SUSF316L
	Fittings <sup>g</sup> > 500 °F (260 °C) (N06625)	—	B446 N06625(g)	N06625	EN 10088-2	NiCr22-M09NB	2.4856	G 4901 NCF625
Austenitic stainless steel	Pressure castings	683-13-10	A351/A351M Gr CF3	J92500	BSI/BS/EN 10213-4	GX2 Cr Ni 19-11	1.4309	G 5121, CI SCS 19A
		683-13-19	A351/A351M Gr CF3M	J92800	BSI/BS/EN 10213-4	GX2 Cr Ni Mo 19-11-2	1.4409	G 5121, CI SCS 16A SCS 16AX
	General castings	—	A743/A743M Gr CF3	J92500	EN 10283	GX2 Cr Ni 19-11	1.4309	G 5121, CI SCS 19A
		—	A743/A743M Gr CF3M	J92800	EN 10283	GX2 Cr Ni Mo 19-11-2	1.4409	G 5121, CI SCS 16A, SCS 16AX
	Wrought/ forgings	9327-5, XCrNi18-10	A182/A182M Gr F 304L <sup>h</sup>	S30403	EN 10222-5	X2 Cr Ni 19-11	1.4306	G 3214, Gr SUS F 304 L <sup>h</sup>
		9327-5, XCrNiMo 17-12	A182/A182M Gr F 316L	S31603	EN 10222-5 EN 10250-4	X2 Cr Ni Mo 17-12-2	1.4404	G 4304/4305, Gr SUS 304L <sup>h</sup> /316L
—	A403 Gr WP304L / WP316L	S30403/ S31603	General Purpose: EN10250-4 Pressure Purpose: EN 10222-5	X2 Cr Ni 19-11 X2 Cr Ni Mo 17-12-2	1.4306 1.4404	G3214 SUSF304L/SUSF316L G4034,4035 SUS304L/SUS316L		

**Table H.2—Material Specifications for Pump Parts (Continued)**

Material Class	Applications	ISO	USA		Europe			Japan
			ASTM	UNS <sup>a</sup>	EN <sup>b</sup>	Grade	Material No.	JIS
Austenitic stainless steel	Bar stock <sup>e</sup>	9327-5 X2CrNi18-10	A479/A479M Type 304L <sup>h</sup> A479/A479M Type 316L A276 Grade 316L	S30403 S31603	EN 10088-3 EN 10088-3	X2 Cr Ni 19-11 X2 Cr Ni Mo 17-12-2	1.4306 1.4404	G 4303 Gr SUS 304 L <sup>h</sup> G 4303 Gr SUS 316 L
		9327-5 X2CrNiMo 17-12	A479/A479M Type XM19	S20910	—	—	—	—
	Plate	9328-5 X2CrNiMo 17-12-2	A240/A240M Gr 304L <sup>h</sup> /316L	S30403 S31603	EN 10028-7 EN 10028-7	X2 Cr Ni 19-11 X2 Cr Ni Mo 17-12-2	1.4306 1.4404	G 4304/4305, Gr SUS 304 L <sup>h</sup> /316 L
	Pipe	683-13-10 683-13-19	A312/A312M Type 304L <sup>h</sup> , 316L	S30403 S31603	—	—	—	G 3459 Gr SUS 304 LTP <sup>h</sup> / 316 LTP
	Fittings	9327-5, X2CrNi18-10 9327-5, X2CrNiMo 17-12	A182/A182M Gr F304L <sup>h</sup> , Gr 316L	S30403 S31603	EN 10222-5	X2 Cr Ni 19-11 X2 Cr Ni Mo 17-12-2	1.4306 1.4404	G 3214 Gr SUS F304L <sup>h</sup> / F316L
	Bolts and studs	3506-1, A4-70	A193/A193M Gr B 8 M	S31600	EN 10250-4	X6 Cr Ni Mo Ti 17-12-2	1.4571	G 4303, Gr SUS 316
	Nuts	3506-2, A4-70	A194/A194M Gr B 8 M	S31600	EN 10250-4	X6 Cr Ni Mo Ti 17-12-2	1.4571	G 4303, Gr SUS 316
Duplex stainless steel	General castings	—	A890/A890M Gr 1B	J93372	BSI/BS/ EN 10213-4	GX2 CrNiMoCuN -25-6-3-3	1.4517	G 5121, Gr SCS 11 / SCS 10
		—	A890/890M Gr 3A	J93371				
		—	A890/890M Gr 4A	J9220				
	Pressure castings	—	A995/A995M Gr 1 B	J93372	BSI/BS/ EN 10213-4	GX2 CrNiMoCuN 25-6-3-3	1.4517	G 5121, Gr SCS 10 / SCS 11
		—	A995/A995M Gr 3A	J93371				
		—	A995/A995M Gr 4A	J9220				
	Wrought/ forgings	9327-5, X2CrNiMoN 22-5-3	A182/A182M Gr F 51	S31803	EN 10250-4 EN 10222-5	X2CrNiMoN 22-5-3	1.4462	—
Bar stock	—	A479/A479M	S32550	EN 10088-3	X2CrNiMoC uN-25-6-3	1.4507	—	
	9327-5, X2CrNiMo N22-5-3	A276-S31803	S31803	EN 10088-3	X2CrNiMoN 22-5-3	1.4462	B 2312/B 2316 Gr SUS 329 J3L	
Plate	—	A240/A240M- S31803	S31803	EN 10028-7	X2CrNiMoN 22-5-3	1.4462	G 4304/G 4305 Gr SUS 329 J3L	

Table H.2—Material Specifications for Pump Parts (Continued)

Material Class	Applications	ISO	USA		Europe			Japan
			ASTM	UNS <sup>a</sup>	EN <sup>b</sup>	Grade	Material No.	JIS
Duplex stainless steel	Pipe	—	A790/A790M-S31803	S31803	—	—	—	G 3459 Gr SUS 329 J3LTP
	Fittings	9327-5, X2CrNiMo N22-5-3	A182/A182M Gr F 51	S31803	EN 10250-4 EN 10222-5	X2CrNiMoN 22-5-3	1.4462	B 2312/B 2316 Gr SUS329J3L
		—	A815/A815M Gr WPS 31803	S31803	EN 10222-5	X2CrNiMoN -22-5-3	1.4462	B2312, B2316 SUS329J3L
	Bolts and studs	—	A276-S31803	S31803	EN 10088-3	X2CrNiMoN 22-5-3	1.4462	G 4303 Gr SUS 329 J3L
		—	A479/A479M S31803	S31803	EN 10088-3	X2CrNiMoN -22-5-3	1.4462	G 4303 SUS329J3L
Nuts	—	A276-S31803	S31803	EN 10088-3	X2CrNiMoN 22-5-3	1.4462	G 4303 Gr SUS 329 J3L	
	—	A479/A479M S31803	S31803	EN 10088-3	X2CrNiMoN -22-5-3	1.4462	G4303 SUS329J3L	
Super duplex stainless steel <sup>f</sup>	General castings	—	A890/A890M Gr 5A	J93404	BSI/BS/ EN 10213-4	GX2CrNiMo N26-7-4	1.4469	—
		—	A890/A890M Gr 6A	J93380				—
	Pressure castings	—	A995/A995M Gr 5A	J93404	BSI/BS/ EN 10213-4	GX2CrNiMo N26-7-4	1.4469	—
		—	A995/995M Gr 6A	J93380	—	—	—	—
	Wrought/ forgings	—	A182/A182M Gr F55 and F53	S32750 S32760	EN 10250-4 EN 10088-3	X2CrNiMoC uWN 25-7-4	1.4501	G 4303, Gr SUS 329 J4L
	Bar stock	—	A276-S32760 A479/A479M- S32750 / S32760	S32750 S32760	EN 10088-3	X2CrNiMoC uWN 25-7-4	1.4501	G 4304/G 4305 Gr SUS 329 J4L
	Plate	—	A240/A240M- S32750 / S32760	S32750 S32760	EN 10028-7	X2CrNiMoC uWN 25-7-4	1.4501	—
	Pipe	—	A790/A790M- S32750 / S32760	S32750 S32760	—	—	—	G 3459, Gr SUS 329 J4LTP
	Fittings	—	A182/A182M Gr F55 and F53 WPS32750 / S32760	S32750 S32760	EN 10250-4 EN 10088-3	X2CrNiMoC uWN 25-7-4	1.4501	B 2312/B 2316 Gr SUS 329 J4L
	Bolts and studs	—	A276-S32750 A276-S32760	S32750 S32760	EN 10088-3	X2CrNiMoC uWN 25-7-4	1.4501	G 4303 Gr SUS 329 J4L
Nuts		—	A276-S32750 A276-S32760	S32750 S32760	EN 10088-3	X2CrNiMoC uWN 25-7-4	1.4501	G 4303 Gr SUS 329 J4L

- a UNS (unified numbering system) designation for chemistry only.
- b Where EN standards do not yet exist, European national standards are available, e.g. AFNOR, BS, DIN, etc.
- c Do not use for shafts in the hardened condition (over 302 HB).
- d Special, normally use 4140 alloy steel..
- e For shafts, standard grades of austenitic stainless steel may be substituted in place of low-carbon (L) grades.
- f Super duplex stainless steel classified with pitting resistance equivalent (PRE) number greater than or equal to 40:  
 $PRE = w_{Cr} + 3.3w_{Mo} + 16w_N$ , where  $w$  is the percentage mass fraction of the element indicated by the subscript.
- g For temperatures  $\leq 500$  °F (260 °C), 316L stainless steel or UN N06625 piping and fittings may be used. For temperatures  $> 500$  °F (260 °C), only UN N06625 piping and fittings shall be used. See 6.4.2.6.
- h Many applications that have moderate corrosion properties do not require the 316/316L and the option of 304/304L is suitable. The option to use 304/304L in for those moderate corrosion applications that do not require the greater corrosion resistance of 316/316L is advised by the vendor.

**Table H.3—Nonmetallic Wear Part Materials**

Material	Temperature limits °F (°C)		Application
	min.	max.	
Polyether ether ketone (PEEK) Chopped-carbon-fiber filled	-20 (-30)	275 (135)	Stationary parts
PEEK Continuous-carbon-fiber wound	-20 (-30)	450 (230)	Stationary or rotating
Perfluoroalkoxy/Carbon-fiber (PFA/CF) Carbon-fiber Filled	-50 (-46)	450 (230)	Stationary parts
Carbon graphite			Stationary parts
Resin-impregnated	-55 (-50)	550 (285)	
Babbitt-impregnated	-400 (-240)	300 (150)	
Nickel-impregnated	-400 (-240)	750 (400)	
Copper-impregnated	-400 (-240)	750 (400)	
Nonmetallic wear part materials that are proven compatible with the specified process liquid may be proposed within the above limits. See 6.7.5 c). Such materials may be selected as wear components for mating against a suitably selected metallic component such as hardened 12 % Cr steel or hard-faced austenitic stainless steel. Materials may be used beyond these limits if proven application experience can be provided and if approved by the purchaser.			

**Table H.4—Piping Materials**

Component	Fluid					
	Auxiliary Process Liquid		Steam		Cooling Water	
	Category		Gauge Pressure kPa (bar; psi)		Nominal Size	
	Pipeline Services <sup>c</sup>	All Weldable Materials	≤ 500 (5; 75)	> 500 (5; 75)	Standard ≤ DN 25 (1 NPS)	Optional ≥ DN 40 (1½ NPS)
Pipe	Seamless <sup>a</sup>	Seamless <sup>a</sup>	Seamless <sup>a</sup>	Seamless <sup>a</sup>	—	Carbon steel, (galvanized to ISO 10684 or ASTM A153/A153M)
Tubing <sup>b</sup>	Stainless steel (Seamless Type 316)	Stainless steel (Seamless Type 316)	Stainless steel (Seamless Type 316)	Stainless steel (Seamless Type 316)	Stainless steel (Seamless Type 316)	—
All valves	Class 800	Class 800	Class 800	Class 800	Class 200 Bronze	Class 200 Bronze
Gate and globe valve	Bolted bonnet and gland	Bolted bonnet and gland	Bolted bonnet and gland	Bolted bonnet and gland	—	—
Pipe fittings and unions	Forged class 3000	Forged class 3000	Forged class 3000	Forged class 3000	Malleable iron (galvanized to ISO 10684 or ASTM A153/A153M)	Malleable iron (galvanized to ISO 10684 or ASTM A153/A153M)
Tube fittings	Manufacturer's standard	Manufacturer's standard	Manufacturer's standard	Manufacturer's standard	Manufacturer's standard	—
Fabricated joints ≤ DN 25 (1 NPS)	Threaded	Socket-welded	Threaded	Socket-welded	Threaded	—
Fabricated joints ≥ DN 40 (1½ NPS)	—	—	—	—	—	Purchaser to specify
Gaskets	—	Austenitic stainless steel spiral-wound	—	Austenitic stainless steel spiral-wound	—	—
Flange bolting <sup>d</sup>	—	4140 alloy steel	—	4140 alloy steel	—	—

<sup>a</sup> Schedule 80 shall be used for pipe sizes from DN 15 to DN 40 (NPS ½ to NPS 1½); schedule 40 shall be used for sizes DN 50 (2 NPS) and larger.

<sup>b</sup> Acceptable tubing sizes (in accordance with ISO 4200) are the following:

12.7 mm dia. × 1.66 mm wall (½ in. dia. × 0.065 in. wall);

19 mm dia. × 2.6 mm wall (¾ in. dia. × 0.095 in. wall);

25 mm dia. × 2.9 mm wall (1 in. dia. × 0.109 in. wall).

<sup>c</sup> Threaded connections only apply to pipeline services with a maximum operating temperature of 130 °F (55 °C). See 6.4.3.2.

<sup>d</sup> 4140 alloy steel bolting shall be PTFE coated (or purchaser-approved equal) or use stainless steel bolting (see 7.6.1.7).



# Annex I (normative)

## Lateral Analysis

### I.1 Lateral Analysis

#### I.1.1 General

If a lateral analysis is required (see 9.2.4.1), the method and assessment of results shall be as specified in I.1.2 through I.1.5. Table I.1 illustrates the analysis process. The method and assessment specified are peculiar to horizontal-axis liquid-handling turbomachines.

**Table I.1—Rotor Lateral Analysis Logic Diagram**

Step	If...	then...
1	the pump and conditions of service are identical or similar to an existing pump with a proven operating record,	analysis is not needed.
2	the rotor is classically stiff (6.9.1.2),	analysis is not needed.
3	neither 1 nor 2 is true,	analysis is required.

#### I.1.2 Natural Frequencies

The report shall state the following:

- a) the rotor's first, second, and third “dry” bending natural frequencies (see 6.9.1.2);

NOTE 1 The “dry” bending natural frequencies serve as useful reference points for subsequent analysis of the damped natural frequencies.

NOTE 2 Usual design practice is to investigate overhung modes, coupling, and thrust collar and set their first bending natural frequency at separation margin at least 20 % above the highest potential excitation frequency (based on maximum continuous speed) before carrying out lateral analysis of the rotor.

- b) all the rotor's damped natural frequencies within the frequency range zero to 2.2 times maximum continuous speed, which shall be calculated for the speed range 25 % to 125 % of rated, taking account of the following:
- 1) stiffness and damping at the following internal running clearances at the expected temperature:
    - as-new clearances, with water,
    - as-new clearances, with the pumped liquid,
    - 2× (two times) the as-new clearances, with the pumped liquid;
  - 2) stiffness and damping at the shaft seals (if labyrinth type);
  - 3) stiffness and damping within the bearings for the average clearance and oil temperature. The effect of bearing stiffness and damping in pumps is generally minor in comparison to that of the internal running clearances; therefore, it is sufficient to analyze the bearings at their average clearance and oil temperature;

- 4) mass and stiffness of the bearing support structure;
- 5) inertia of the pump half-coupling hub and half the coupling spacer;

NOTE Though the higher order damped natural frequencies can be close to impeller vane passing frequency, there is no experience in liquid-handling turbomachines pointing to rotor-dynamics problems caused by such proximity. This is deemed a consequence of the complex mode shape(s), relatively low excitation energy, and sufficient damping at the higher frequencies involved.

- c) values or the basis of the stiffness and damping coefficients used in the calculation.

### 1.1.3 Separation Margins and Damping

For both as-new and 2× as-new clearances, the damping factor vs separation margin between any bending natural frequency and the synchronous run line shall be within the “acceptable” region shown on Figure I.1. If this condition cannot be satisfied, the damped response to unbalance shall be determined (see I.1.4).

NOTE In liquid-handling turbomachines, the first assessment of a rotor's dynamic characteristics is based on damping vs separation margin, rather than amplification factor vs separation margin. Two factors account for this basis. First, the rotor's natural frequencies increase with rotational speed, a consequence of the differential pressure across internal clearances also increasing with rotational speed. On a Campbell diagram (see Figure I.2), this means that the closer separations are between the running speed and natural frequencies rather than between the running speed and the critical speeds. Because the amplification factor at the closer separations is not related to synchronous (unbalance) excitation of the rotor, it can be developed only by an approximate calculation based on the damping. Second, employing damping allows the specification of a minimum value for natural frequency to running speed ratios from 0.8 to 0.4, thereby assuring that the rotor is free from significant subsynchronous vibration.

The logarithmic decrement,  $\delta$ , is related to the damping factor,  $\xi$ , as given in Equation (I.1):

$$\delta = (2\pi\xi)/(1 - \xi^2)^{0.5} \quad (I.1)$$

For  $\xi$  up to 0.4, the approximate relationships given in Equation (I.2) between  $\xi$ ,  $\delta$ , and amplification factor,  $F_a$ , are sufficiently accurate for practical purposes:

$$\begin{aligned} \xi &= \delta/2\pi \\ &= 1/(2 \times F_a) \end{aligned} \quad (I.2)$$

In liquid-handling turbomachines, critically damped conditions correspond to the following:

$$\xi \geq 0.15$$

$$\delta \geq 0.95$$

$$F_a \leq 3.33$$

NOTE 1 The values given for critically damped conditions in liquid-handling turbomachines differ from those in API standards for gas- or vapor-handling turbomachines. The difference reflects successful operating experience with liquid-handling turbomachines designed using the values in this annex.

NOTE 2 Damping of  $\xi \geq 0.08$  over the range  $f_{ni}/f_{run}$  0.8 to 0.4 is supported by design and operating experience with liquid-handling turbomachines, which demonstrates that designs satisfying this requirement have not suffered problems with subsynchronous rotor vibration.

### **I.1.4 Damped Unbalance Response Analysis**

If the damping factor vs separation margin for a mode or modes is not acceptable by the criteria in Figure I.1, the rotor's damped response to unbalance shall be determined for the mode(s) in question on the following basis:

- a) the pumped liquid;
- b) clearance condition(s), as-new or 2× as-new, causing inadequate separation margin vs damping;
- c) total unbalance of four times (4×) the allowable value (see 9.2.4.2.1) lumped at one or more points to excite the mode(s) being investigated.

Only one mode shall be investigated in each computer run.

### **I.1.5 Allowable Displacement**

The peak-to-peak displacement of the unbalanced rotor at the point(s) of maximum displacement shall not exceed 35 % of the diametral running clearance at that point.

**NOTE** In centrifugal pumps, the typical damped response to unbalance does not show a peak in displacement at resonance large enough to assess the amplification factor. With this limitation, assessment of the damped response to unbalance is restricted to comparing rotor displacement to the available clearance.

## **I.2 Shop Verification of Rotor Dynamic Characteristics**

- **I.2.1** If specified, the dynamic characteristics of the rotor shall be verified during the shop test. The rotor's actual response to unbalance shall be the basis for confirming the validity of the damped lateral analysis. This response is measured during either variable-speed operation from rated speed down to 75 % of the first critical speed or during coast-down. If the damped response to unbalance was not determined in the original rotor analysis (see I.1.4), this response shall be determined for a pump with new clearances handling water before proceeding with shop verification. The test unbalances shall be vectorially added in phase with the residual unbalance, at locations determined by the manufacturer (usually at the coupling and/or thrust collar).

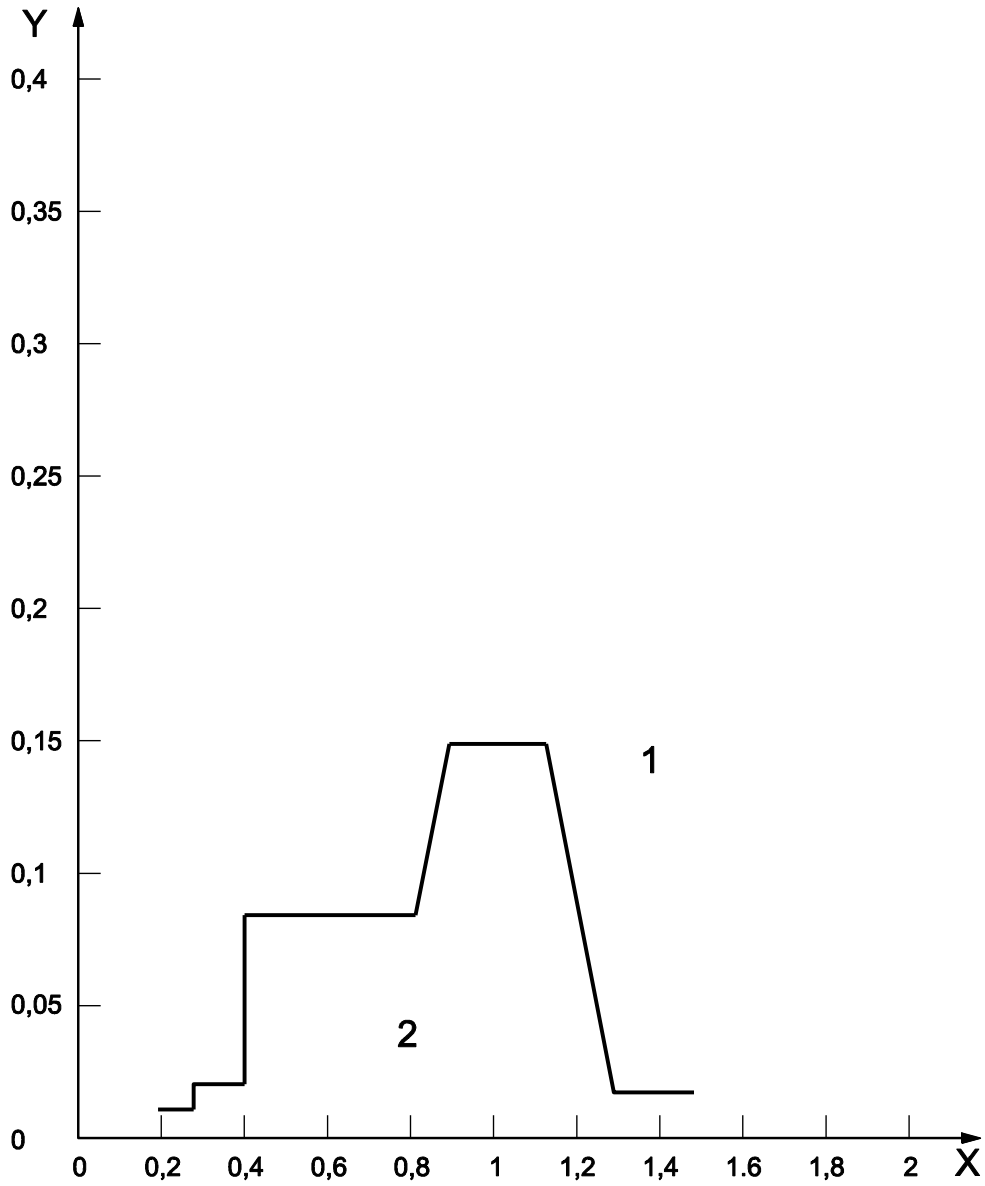
**NOTE** The principal objective of shop verification by response to unbalance is to verify the existence of a critical speed (vibration peak) within the tolerance of the calculated value or, if the analysis predicted a highly damped critical speed, the absence of a vibration peak within tolerance of the calculated value. Shop verification by this method is feasible only for pumps that have sleeve bearings and that are furnished with proximity probe pairs at each journal bearing.

**I.2.2** The magnitude and location of the test unbalance(s) shall be determined from a calibration of the rotor's sensitivity to unbalance. The calibration shall be performed by obtaining the vibration orbits at each bearing, filtered to rotor speed (1×), during two trial runs as follows:

- a) with the rotor as-built;
- b) with trial unbalance weights added 90° from the maximum displacement in Run a).

The magnitude of the test unbalances shall be such that the calculated maximum shaft displacement caused by the resultant total unbalance (residual plus test) is 150 % to 200 % of the allowable displacement from Table 8 or Table 9 at the bearing probes but shall not exceed eight times the maximum allowable rotor unbalance.

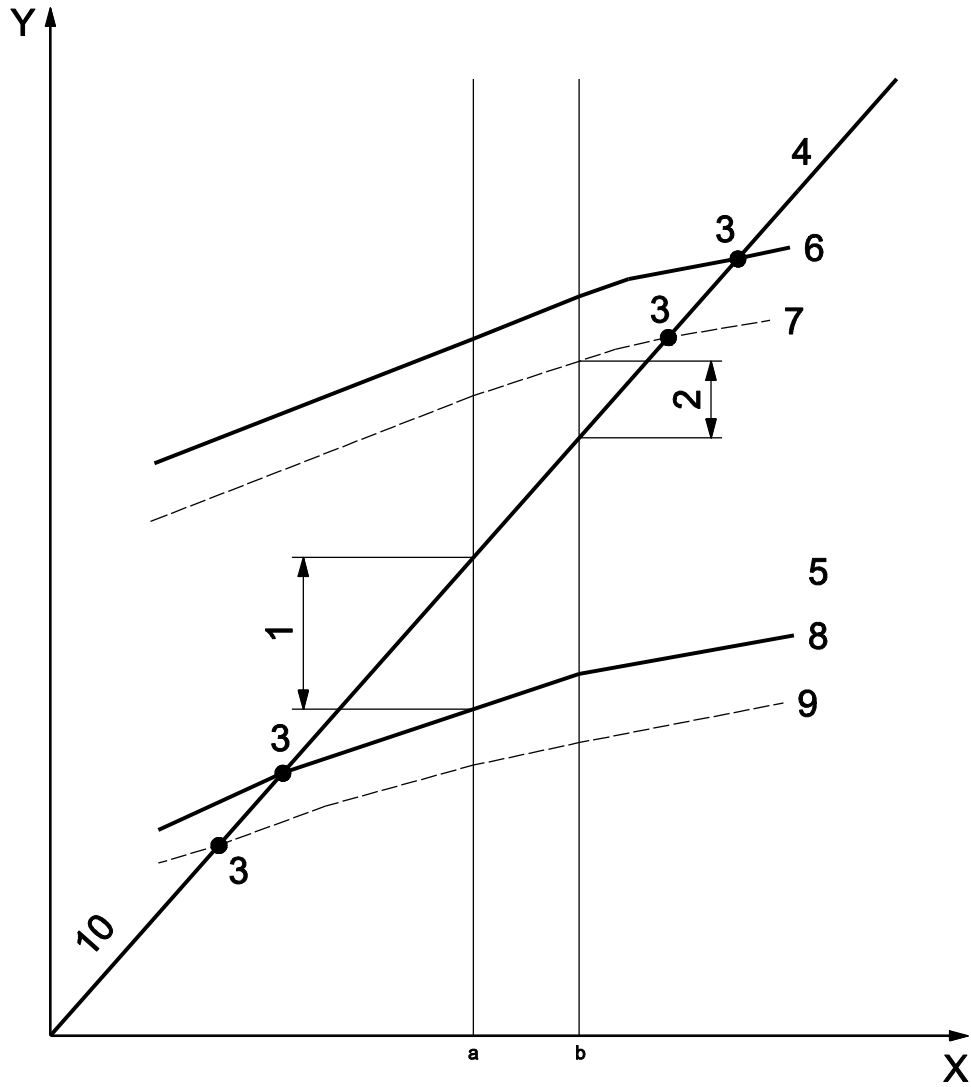
**I.2.3** During the test, the rotor's speed, vibration displacement, and corresponding phase angle, filtered to rotor speed (1×), shall be measured and recorded.



**Key**

- X frequency ratio,  $f_n/f_{run}$
- Y damping factor,  $\xi$
- 1 acceptable region
- 2 unacceptable region

**Figure I.1—Damping Factor vs Frequency Ratio**



**Key**

- |   |  |    |                  |
|---|--|----|------------------|
| X | pumping speed, expressed in revolutions per minute | 6  | as-new clearance |
| Y | frequency, $f_n$                                   | 7  | 2× clearance     |
| 1 | minimum separation margin, 1st $f_n$               | 8  | as-new clearance |
| 2 | minimum separation margin, 2nd $f_n$               | 9  | 2× clearance     |
| 3 | critical speeds                                    | 10 | run line         |
| 4 | second bending                                     | a  | Minimum.         |
| 5 | first bending                                      | b  | Maximum.         |

**Figure I.2—Typical Campbell Diagram**

**1.2.4** The rotor's characteristics shall be considered verified if the following requirements are met:

- a) observed critical speed(s) (distinct vibration peak and appropriate phase shift) within  $\pm 10\%$  of the calculated value(s);
- b) measured vibration amplitudes within 35 % of the calculated values.

Highly damped critical speeds might not be observable; therefore, the absence of rotor response in the region of a calculated highly damped critical speed is verification of the analysis.

**1.2.5** If the acceptance criteria given in 1.2.4 are not met, the stiffness or damping coefficients, or both, used in the natural frequency calculation shall be adjusted to produce agreement between the calculated and measured results. The coefficients of one type of element, annular clearances with  $L/D < 0.15$ , annular clearances  $L/D > 0.15$ , impeller interaction, and bearings shall be adjusted with the same correction factor. Once agreement is reached, the same correction factors shall be applied to the calculation of the rotor's natural frequencies and damping for the pumped liquid, and the rotor's separation margins vs damping factors rechecked for acceptability.

Of the coefficients used in rotor lateral analysis, those for damping in annular clearances have the highest uncertainty and are, therefore, usually the first that are adjusted. The stiffness coefficients of annular clearances typically have a low uncertainty and, therefore, shall be adjusted only on the basis of supporting data. Adjustments of bearing coefficients require specific justification because the typical values are based on reliable empirical data.

**1.2.6** Alternative methods of verifying the rotor's dynamic characteristics, e.g. variable-frequency excitation with the pump at running speed to determine the rotor's natural frequencies, are available. The use of alternative methods and the interpretation of the results shall be agreed between the purchaser and manufacturer.

### **1.3 Documentation**

The report on a lateral analysis shall include the following:

- a) results of initial assessment (see 9.2.4.1);
- b) fundamental rotor data used for the analysis, which may be the fundamental model;
- c) Campbell diagram (see Figure 1.2);
- d) plot of damping ratio vs separation margin;
- e) mode shape at the critical speed(s) for which the damped response to unbalance is determined (see 1.1.4);
- f) Bode plot(s) from shop verification by unbalance (see 1.2.3);
- g) summary of analysis corrections to reach agreement with shop verification (see 1.2.5).

Items e) through g) shall be furnished only if the activity documented is required by the analysis or specified by the purchaser.

# Annex J (normative)

## Determination of Residual Unbalance

### J.1 General

This annex describes the procedure used to determine residual unbalance in machine rotors. Although some balancing machines may be set up to read out the exact amount of unbalance, the calibration can be in error. The only sure method of determining residual unbalance is to test the rotor with a known amount of unbalance.

### J.2 Terms and Definitions

#### J.2.1

##### **residual unbalance**

Amount of unbalance remaining in a rotor after balancing.

NOTE Unless otherwise specified, residual unbalance is expressed in ounce-inches (oz-in.) [gram-millimeters (g-mm)].

### J.3 Maximum Allowable Residual Unbalance

**J.3.1** The maximum allowable residual unbalance per plane shall be determined from Table 19.

**J.3.2** If the actual static load on each journal is not known, assume that the total rotor mass is equally supported by the bearings. For example, a two-bearing rotor with a mass of 6000 lb (2700 kg) can be assumed to impose a mass of 3000 lb (1350 kg) on each journal.

### J.4 Residual Unbalance Check

#### J.4.1 General

**J.4.1.1** If the balancing machine readings indicate that the rotor has been balanced to within the specified tolerance, a residual unbalance check shall be performed before the rotor is removed from the balancing machine.

- **J.4.1.2** To check the residual unbalance, a known trial mass is attached to the rotor sequentially in 6 (or 12, if specified by the purchaser) equally spaced radial positions, each at the same radial distance. The check is run in each correction plane, and the readings in each plane are plotted on a graph using the procedure specified in J.4.2.

#### J.4.2 Procedure

**J.4.2.1** Select a trial mass and radius that provides between one and two times the maximum allowable residual unbalance [i.e. if  $U_{\max}$  is 2 oz-in. (1440 g-mm), the trial mass is expected to cause 2 oz-in. to 4 oz-in. (1440 g-mm to 2880 g-mm) of unbalance].

**J.4.2.2** Starting at the last known heavy spot in each correction plane, mark off the specified number of radial positions (6 or 12) in equal ( $60^\circ$  or  $30^\circ$ ) increments around the rotor. Add the trial mass to the last known heavy spot in one plane. If the rotor has been balanced very precisely and the final heavy spot cannot be determined, add the trial mass to any one of the marked radial positions.

**J.4.2.3** To verify that an appropriate trial mass has been selected, operate the balancing machine and record the reading on the meter. If the reading is at the upper limit of the meter range, a smaller trial mass shall be

used. If there is little or no meter reading, a larger trial mass shall be used. Little or no meter reading generally indicates that the rotor was either not balanced correctly, or the balancing machine is not sensitive enough, or the balancing machine is faulty (e.g. a faulty transducer). Whatever the error, it shall be corrected before proceeding with the residual check.

**J.4.2.4** Locate the mass at each of the equally spaced positions in turn, and record the amount of unbalance indicated on the meter for each position. Repeat the initial position as a check. All verification shall be performed using only one sensitivity range on the balance machine.

**J.4.2.5** Plot the readings on the residual unbalance worksheet and calculate the amount of residual unbalance (see Figure J.1 and Figure J.2). The maximum meter reading occurs when the trial mass is added at the rotor's heavy spot; the minimum reading occurs when the trial mass is located opposite the heavy spot. Thus, the plotted readings are expected to form an approximate circle (see Figure J.3 and Figure J.4). An average of the maximum and minimum meter readings represents the effect of the trial mass. The distance of the circle's center from the origin of the polar plot represents the residual unbalance in that plane.

**J.4.2.6** Repeat the steps described in J.4.2.1 through J.4.2.5 for each balance plane. If the specified maximum allowable residual unbalance is exceeded in any balance plane, the rotor shall be balanced more precisely and checked again. If a correction is made to any balance plane, the residual unbalance check shall be repeated in all planes.

**J.4.2.7** For progressively balanced rotors, a residual unbalance check shall be performed after the addition and balancing of the first rotor component, and at the completion of balancing of the entire rotor, as a minimum.

**NOTE** This ensures that time is not wasted and rotor components are not subjected to unnecessary material removal in attempting to balance a multiple-component rotor with a faulty balancing machine.



Equipment (rotor) no.: \_\_\_\_\_

Purchase order no.: \_\_\_\_\_

Correction plane (inlet, drive end, etc.—use sketch): \_\_\_\_\_

Balancing speed: \_\_\_\_\_ r/min

$n$  = maximum allowable rotor speed: \_\_\_\_\_ r/min

$m$  (or  $W$ ) = mass of journal (closest to this correction plane): \_\_\_\_\_ lb (kg)

$U_{max}$  = maximum allowable residual unbalance =  $6350m/n$  ( $4W/n$ )

$4 \times$  \_\_\_\_\_ lb/\_\_\_\_\_ r/min; ( $6350 \times$  \_\_\_\_\_ kg/\_\_\_\_\_ r/min) \_\_\_\_\_ (oz-in.) g-mm

Trial unbalance ( $2 \times U_{max}$ ) \_\_\_\_\_ (oz-in.) g-mm

$R$  = radius of mass placement: \_\_\_\_\_ in. (mm)

Trial unbalance mass = Trial unbalance/ $R$

\_\_\_\_\_ oz-in./\_\_\_\_\_ in. (\_\_\_\_\_ g-mm/\_\_\_\_\_ mm) \_\_\_\_\_ oz (g)

NOTE Conversion information: 1 oz = 28.350 g

Test Data			Rotor Sketch
Position	Trial Mass Angular Location	Balancing Machine Amplitude Readout	
1			
2			
3			
4			
5			
6			
7			

**Test Data—Graphic Analysis**

Step 1: Plot data on the polar chart (Figure J.2). Scale the chart so the largest and smallest amplitudes will fit conveniently.

Step 2: With a compass, draw the best-fit circle through the six points and mark the center of this circle.

Step 3: Measure the diameter of the circle in units of scale chosen in Step 1 and record. \_\_\_\_\_ units

Step 4: Record the trial unbalance from above. \_\_\_\_\_ oz-in. (g-mm)

Step 5: Double the trial unbalance in Step 4 (may use twice the actual residual unbalance). \_\_\_\_\_ oz-in. (g-mm)

Step 6: Divide the answer in Step 5 by the answer in Step 3. \_\_\_\_\_ scale factor

You now have a correlation between the units on the polar chart and the actual balance.

**Figure J.1—Residual Unbalance Worksheet**

The circle you have drawn shall contain the origin of the polar chart. If it does not, the residual unbalance of the rotor exceeds the applied test unbalance.

NOTE Several possibilities for the drawn circle not including the origin of the polar chart are operator error during balancing, a faulty balancing machine transducer or cable, or a balancing machine not sensitive enough.

If the circle does contain the origin of the polar chart, the distance between origin of the chart and the center of your circle is the actual residual unbalance present on the rotor correction plane. Measure the distance in units of scale you chose in Step 1 and multiply this number by the scale factor determined in Step 6. Distance in units of scale between origin and center of the circle times scale factor equals actual residual unbalance.

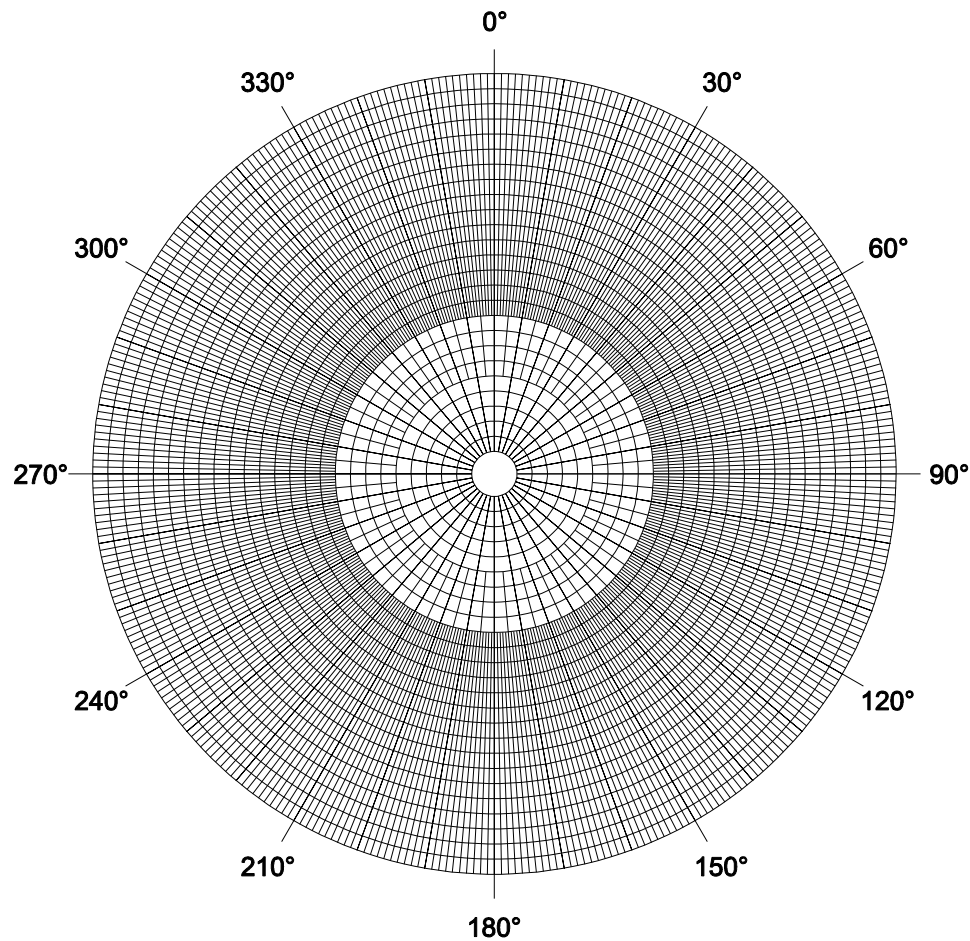
Record actual residual unbalance \_\_\_\_\_ oz-in. (g-mm)

Record allowable residual unbalance \_\_\_\_\_ oz-in. (g-mm)

Correction plane \_\_\_\_\_ for rotor No. \_\_\_\_\_ (has/has not) passed.

By \_\_\_\_\_ Date \_\_\_\_\_

**Figure J.1—Residual Unbalance Worksheet (Continued)**



**Figure J.2—Residual Unbalance Worksheet—Polar Chart**

Equipment (rotor) no.: C-101

Purchase order no.: \_\_\_\_\_

Correction plane (inlet, drive end, etc.—use sketch): A

Balancing speed: \_\_\_\_\_ 800 r/min

$n$  = maximum allowable rotor speed: \_\_\_\_\_ 10,000 r/min

$m$  (or  $W$ ) = mass of journal (closest to this correction plane): \_\_\_\_\_ 908 (lb)

$U_{\max}$  = maximum allowable residual unbalance =  $6350m/n$  ( $4W/n$ )

$4 \times 908 \text{ lb}/10,000 \text{ r/min}$  \_\_\_\_\_ 0.36 (oz-in.)

Trial unbalance ( $2 \times U_{\max}$ ) \_\_\_\_\_ 0.72 (oz-in.)

$R$  = radius of mass placement: \_\_\_\_\_ 6.875 (in.)

Trial unbalance mass = Trial unbalance/ $R$

0.72 oz-in./6.875 in. \_\_\_\_\_ 0.10 (oz)

NOTE Conversion information: 1 oz = 28.350 g

Test Data			Rotor Sketch
Position	Trial Mass Angular Location	Balancing Machine Amplitude Readout	
1	0°	14.0	
2	60°	12.0	
3	120°	14.0	
4	180°	23.5	
5	240°	23.0	
6	300°	15.5	
7	0°	13.5	

### Test Data—Graphic Analysis

Step 1: Plot data on the polar chart (Figure J.4). Scale the chart so the largest and smallest amplitudes will fit conveniently.

Step 2: With a compass, draw the best-fit circle through the six points and mark the center of this circle.

Step 3: Measure the diameter of the circle in units of scale chosen in Step 1 and record. \_\_\_\_\_ 35 units

Step 4: Record the trial unbalance from above. \_\_\_\_\_ 0.72 (oz-in.)

Step 5: Double the trial unbalance in Step 4 (may use twice the actual residual unbalance). \_\_\_\_\_ 1.44 (oz-in.)

Step 6: Divide the answer in Step 5 by the answer in Step 3. \_\_\_\_\_ 0.041 scale factor

You now have a correlation between the units on the polar chart and the actual balance.

### Figure J.3—Example of Completed Residual Unbalance Worksheet <sup>16</sup>

<sup>16</sup> This example is merely for illustration purposes only. [Each company shall develop its own approach.] They are not to be considered exclusive or exhaustive in nature. API makes no warranties, express or implied for reliance on or any omissions from the information contained in this document.

The circle you have drawn shall contain the origin of the polar chart. If it does not, the residual unbalance of the rotor exceeds the applied test unbalance.

NOTE Several possibilities for the drawn circle not including the origin of the polar chart are operator error during balancing, a faulty balancing machine transducer or cable, or a balancing machine that is not sensitive enough.

If the circle does contain the origin of the polar chart, the distance between origin of the chart and the center of your circle is the actual residual unbalance present on the rotor correction plane. Measure the distance in units of scale you chose in Step 1 and multiply this number by the scale factor determined in Step 6. Distance in units of scale between origin and center of the circle times scale factor equals actual residual unbalance.

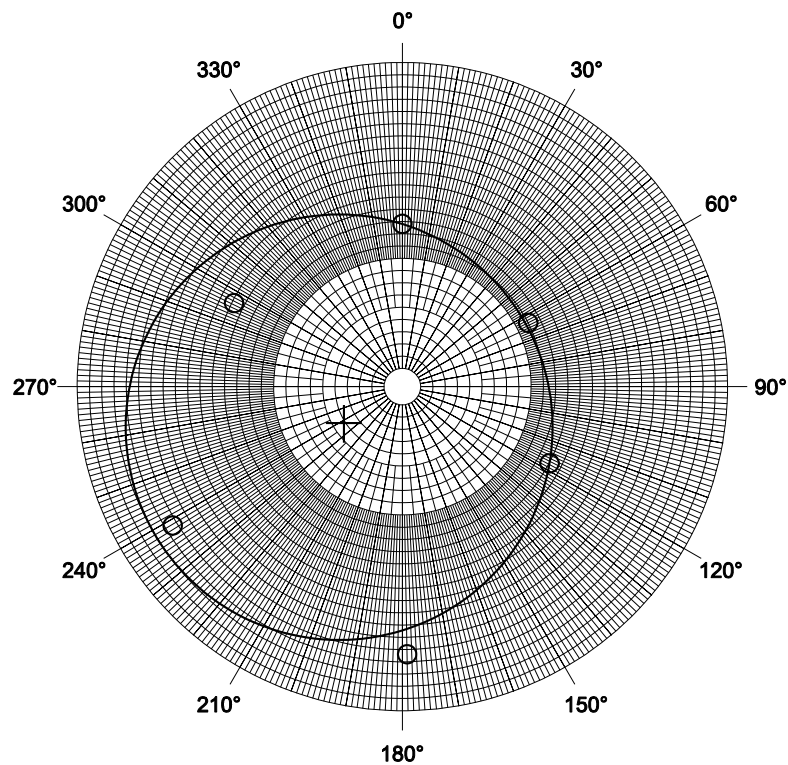
Record actual residual unbalance \_\_\_\_\_  $6.5 (0.041) = 0.27$  \_\_\_\_\_ (oz-in.)

Record allowable residual unbalance \_\_\_\_\_  $0.36$  \_\_\_\_\_ (oz-in.)

Correction plane \_\_\_\_\_  $A$  \_\_\_\_\_ for rotor No. \_\_\_\_\_  $C-101$  \_\_\_\_\_ (has) passed.

By \_\_\_\_\_  $John\ Inspector$  \_\_\_\_\_ Date \_\_\_\_\_  $2002-04-30$  \_\_\_\_\_

**Figure J.3—Example of Completed Residual Unbalance Worksheet (Continued)**



**Figure J.4—Example of Completed Residual Unbalance Worksheet—  
Best-fit Circle for Residual Unbalance**<sup>17</sup>

<sup>17</sup> This example is merely for illustration purposes only. [Each company shall develop its own approach.] They are not to be considered exclusive or exhaustive in nature. API makes no warranties, express or implied for reliance on or any omissions from the information contained in this document.

## Annex K (informative)

### Shaft Stiffness and Bearing System Life

#### K.1 Guideline on Shaft Stiffness for Overhung Pump Types OH2 and OH3

K.1 presents a standardized method for calculation of overhung pump SFI.

The design and operation requirements for overhung pump rotors are detailed in several areas of this standard. This subsection lists these requirements and establishes a standardized process of calculating a SFI that may be used to evaluate these latter parameters and to establish a baseline for the comparison of shaft flexibility.

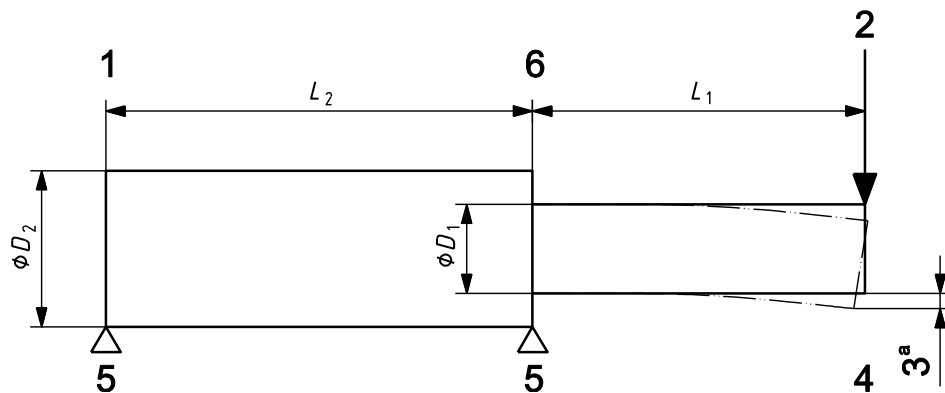
For a shaft of two diameters,  $D_1$  under the seal sleeve and  $D_2$  between the bearings (see Figure K.1), the shaft stiffness is inversely proportional to what is generally termed the shaft flexibility index, SFI or  $I_{SF}$ , defined as given in Equation (K.1):

$$I_{SF} = L_1^3/D_1^4 + L_1L_2^2/D_2^4 \quad (K.1)$$

where  $L_1$  is the overhang centerline of impeller to line bearing) and  $L_2$  is the bearing span.

In rotor designs typical of refinery pumps,  $D_2 > D_1$  and  $L_2 < L_1$ , the second term accounts for only about 20 % of the total value of  $I_{SF}$ , so the convention is to assess overhung pump shaft stiffness using a shortened expression as given in Equation (K.2):

$$I_{SF} = L_1^3/D_1^4 \quad (K.2)$$



**Key**

- |                               |                     |
|-------------------------------|---------------------|
| 1 simplified shaft            | 4 impeller end      |
| 2 radial load on the impeller | 5 support (bearing) |
| 3 deflection                  | 6 overhang pump     |

**Figure K.1—Simple Overhung Rotor**

The shortened calculation for  $I_{SF}$ , Equation (K.2), was used extensively by refiners in the 1970s and 1980s to compare overhung pump rotor stiffness and assign a maintenance cost factor to the price of pumps whose  $I_{SF}$  was some multiple, typically 1.2, of the lowest value of the pumps offered for the service. That practice led to the development of the higher stiffness rotors necessary to achieve longer pump mean time between repair (MTBR) and in the 1990s, lower shaft-seal leakage for reduced VOC emissions. Because the assessments

were applied to pumps for a given application, the comparison was between pumps of similar size. To provide general guidance on values of  $I_{SF}$ , it is, therefore, necessary to relate  $I_{SF}$  to pump size.

Overhung-refinery-pump bearing frames are designed in discrete sizes. The shaft for each is, therefore, designed for the maximum torque, impeller mass, and impeller radial load (static and dynamic) of the largest liquid end the frame is intended to serve. Impeller mass is significant in that it is necessary for the rotor's first dry bending critical speed to be 120 % of the pump's maximum continuous operating speed (see 6.9.1.2). At the same time, deflection at the seal faces produced by radial thrust shall not exceed 0.002 in. (50  $\mu$ m) (6.9.1.3).

The loads imposed on the shaft are directly related to the size of the impeller and, hence, to the flow, total head and speed of the pump. This allows the definition of a "size" factor,  $K_t$ , as given in Equation (K.3):

$$K_t = (Q \times H)/N \quad (\text{K.3})$$

where

$Q$  is flow at BEP of maximum diameter impeller;

$H$  is the corresponding total head;

$N$  is the rotational speed.

The size factor is related to torque. A log-log plot of  $I_{SF}$  vs  $K_t$  for various overhung pump designs ranging from 35 hp to 500,000 hp (25 kW to 350,000 kW), with the higher value for large pump-turbines, shows that the data for modern designs fall about a straight line; see Figure K.2 and Figure K.3. The line of best fit through the high side of the data is also shown.

The high-side line of best fit is defined by Equation (K.4) in SI units and by Equation (K.5) for USC units:

$$I_{SF,SI} = 32 \times K_t^{-0.76} \quad (\text{K.4})$$

$$I_{SF,USC} = 6200 \times K_t^{-0.76} \quad (\text{K.5})$$

Equations (K.4) and (K.5) cover refinery pumps whose rotors, at the limit of each frame, reportedly just meet the static deflection and rotor dynamics requirements of this standard based on rated speeds up to 3600 rpm. The liquid-end designs generally have double volutes for all pumps of 4 in. (100 mm) discharge and larger. In some cases the designs may be limited to 3000 rpm.

Figure K.2 and Figure K.3 or Equations (K.4) and (K.5) can be used to make a first assessment of the rotor stiffness of a given overhung pump design or a number of similar designs for a given application. An overhung pump whose  $I_{SF}$  is more than 1.2 times the chart or equation value is cause to seek justification of the design from the pump vendor.

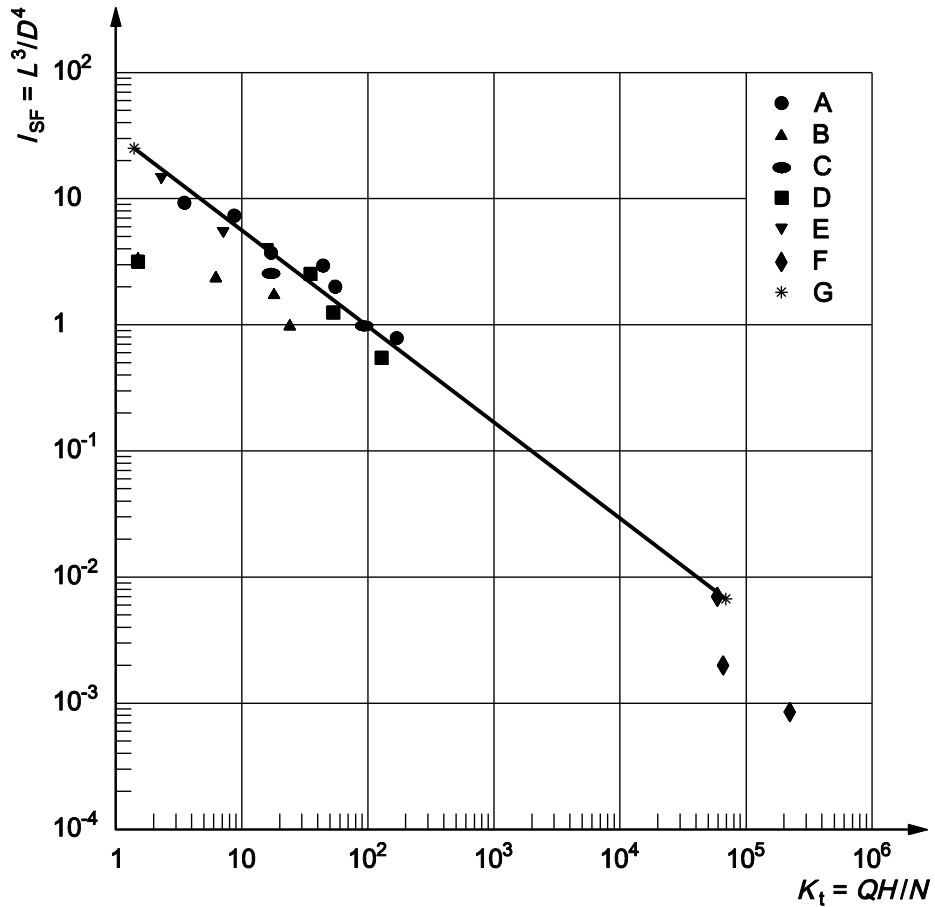


Figure K.2—Overhung Pump Shaft Flexibility Index vs Size Factor (SI Units)

## K.2 Bearing System Life Considerations for OH2, OH3, BB1, BB2, and BB3 Pumps

K.2 presents a method of calculating bearing system life. If specified, bearing system life calculations shall be furnished (see 6.10.1.6).

Bearing system life (the calculated life of the combined system of bearings in the pump) shall be equivalent to at least 25,000 h with continuous operation at rated conditions, and at least 16,000 h at maximum radial and axial loads and rated speed. This section contains a discussion of these requirements.

This standard requires that pumps be designed for 20 years life and 3 years continuous service. Thus, it is necessary that the bearing “system,” not just the individual bearings alone, be designed for a minimum life of 3 years. This is not normally a problem and most user reliability statistics show that bearing life is not a major determinant of overall pump reliability. In cases where bearing life is an issue, the root causes are usually related to lubrication.

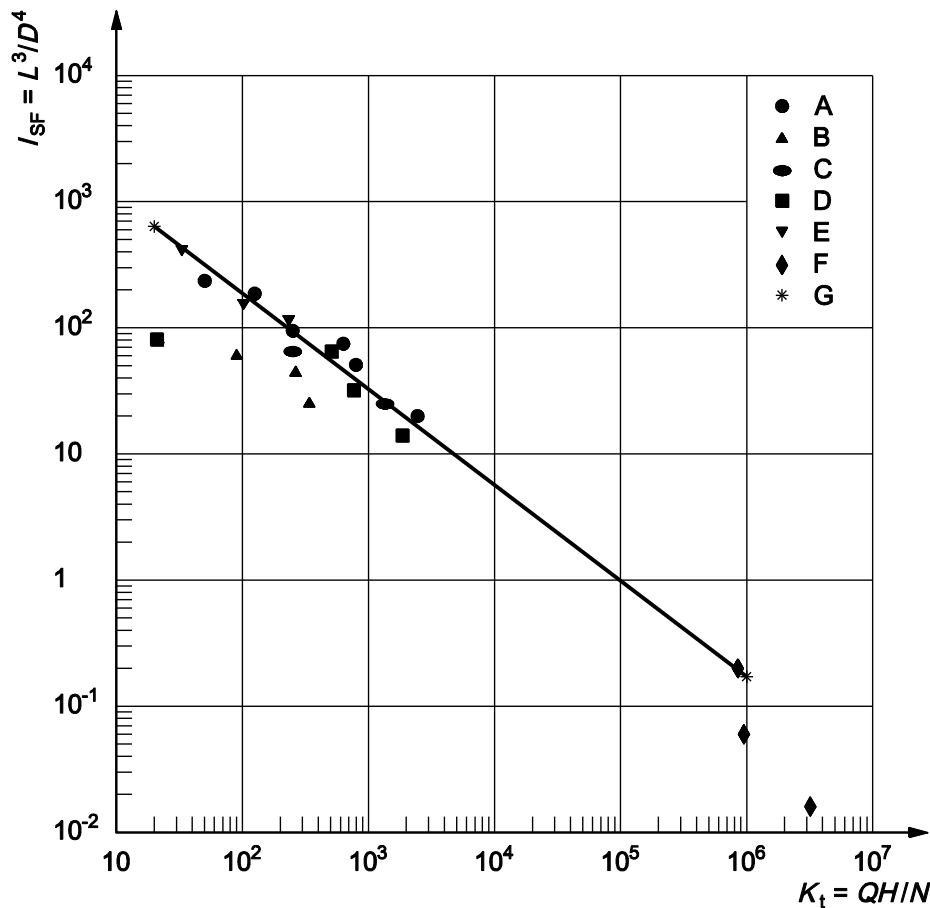


Figure K.3—Overhung Pump Shaft Flexibility Index vs Size Factor (USC Units)

Historically, this standard has required that “individual” bearings be designed for a minimum  $L_{10h}$  life of 25,000 h and 16,000 h at the maximum radial and axial loads and rated speed. Bearing-system life,  $L_{10h,sys}$ , is calculated using Equation (K.6) and, therefore, is shorter than the shortest life of the individual bearings in the system:

$$L_{10h,sys} = [(1/L_{10hA})^{3/2} + (1/L_{10hB})^{3/2} + \dots + (1/L_{10hN})^{3/2}]^{-2/3} \quad (K.6)$$

where

$L_{10hA}$  is the basic rating life,  $L_{10h}$ , in accordance with ISO 281 for bearing A;

$L_{10hB}$  is the basic rating life,  $L_{10h}$ , in accordance with ISO 281 for bearing B;

$L_{10hN}$  is the basic rating life,  $L_{10h}$ , in accordance with ISO 281 for bearing  $N$ .

**EXAMPLE 1** If a pump has two bearings of equal  $L_{10h}$  life (not very likely) and a bearing system life of 25,000 h, the individual bearings would have a  $L_{10h}$  life of approximately 37,500 h. Note that because rolling-element bearings are manufactured in standard sizes, it is unlikely that any particular pump would have a calculated  $L_{10h}$  life of exactly 37,500 h for both bearings in the system.

**EXAMPLE 2** If one bearing has a calculated  $L_{10h}$  life of 100,000 h (not unusual), it is necessary for the other bearing in the system to have a calculated  $L_{10h}$  life of only about 25,700 h to give a bearing system life of approximately 25,000 h.



OH2, OH3, and to a lesser extent, BB1, BB2, and BB3, pumps are not totally “engineered pumps” in that each component is not necessarily “designed” for a particular purchaser’s order requirements. They are generally “design lines of pumps,” or pumps that are “pre-engineered” by the manufacturer to meet the requirements of this standard within a particular range of operating conditions for specific applications. This is particularly true for BB designs that can have multiple rotor and volute designs within one case pattern using several bearing housing and seal chamber designs. These “pre-engineered” pumps may then be modified, as required, to meet unique applications and purchaser requirements. In the design/product line development process for these pumps, the manufacturer chooses a set of extreme conditions within which he/she desires to sell “standard pumps.” These conditions vary according to the manufacturer’s experience with the breadth of services his/her customers require. These conditions can be chosen to encompass 98 % of all refinery services into which he/she has sold pumps in, say, a 10 year period.

Once the range of operating conditions has been established, the manufacturer chooses a number of bearing-frame sizes. For most pump manufacturers, this is either three or four sizes for these types of pumps. The manufacturer then matches his/her available or anticipated sets of hydraulics to the various bearing frames. For each bearing frame, there is a set of hydraulics that imposes the greatest loads on the bearings and frame. For this set of hydraulics, it is necessary that the minimum bearing system life meet the requirements of this standard. However, it is completely possible that there are sets of operating conditions or service parameters (such as high suction pressure, low running speed, operating pumps outside the preferred or allowable operating regions) where this pump does not meet all the requirements of this standard. For these conditions, the manufacturer has a number of options, including modifying the pump design to meet all the requirements, limiting the pump operating range, or negotiation with the purchaser to accept a slightly lower bearing-system life in order to reduce cost or improve overall bearing performance. This can be beneficial if operating conditions are such that bearing loads vary significantly and can result in loads that are too low for optimal bearing performance.

For all other sets of hydraulics, the bearing loads are lower. The equation for bearing life,  $L_{10h}$ , as a function of load is given by Equation (K.7), taken from ISO 281:2007, Equation (4):

$$L_{10} = (C_r/P_r)^x \quad (\text{K.7})$$

where

$C_r$  is the dynamic load rating of the bearing;

$P_r$  is the equivalent dynamic load;

$x$  is 3 for ball bearings and 10/3 for roller bearings.

One can find methods of determining the bearing loads for a pump in the Hydraulic Institute standards.

Examining Equation (K.6), one can see that for a given bearing, with a given load, a reduction in applied load of 10 % results in an increase in bearing life of approximately 37 %. This means that the calculated bearing-system life for all pumps with a given bearing frame is much greater than the bearing-system life requirement of this standard that is applied to the largest set of hydraulics for that bearing frame. Further, for the largest bearing frame, the system life is also greater if the impeller is at less-than-maximum diameter, if the specific gravity is low or if the suction pressure is lower than that used in the limiting case. Further, because bearings with the smallest size having ratings that exceed the calculated loads are chosen, even the largest set of hydraulics can well have a much higher calculated bearing-system life. This gives some insight as to why the historical requirement of 25,000 h  $L_{10h}$  life for individual bearings has not been a problem.

It is noted that there are rolling-element bearings much larger and with much higher dynamic load ratings that are used in pumps compliant with this standard. The application of rolling-element bearings is limited by bearing size and the speed of rotation. It has been found by the pump industry that large bearings running at two-pole speeds (3000 and 3600 nominal r/min) tend to run “hot” and can exceed the maximum bearing

temperature requirements of this standard. As a result of this, all manufacturers limit angular-contact thrust bearings to about 7315 or 7316 sizes for two-pole machines. These correspond to shaft sizes of 2.95 in. and 3.1 in. (75 mm and 80 mm), respectively.

While hot running is detrimental to lubricant and bearing life, the most problematic issue is ball skidding in lightly loaded bearings. If a pump manufacturer applies larger bearings for each frame size, it is necessary that he/she limit the application of each bearing frame to hydraulics that provide bearing loads sufficient to minimize ball skidding. This means additional bearing-frame sizes can be required to cover all pump sizes in a given product line, thus reducing component production volume, interchangeability, and stocking opportunities.

The issue of bearing-system life is an application limitation for pumps of “standard designs.”

## **Annex L** (informative)

### **Contract Documents and Engineering Design Data**

**L.1** When specified by the purchaser in 10.2, the contract documents and engineering design data shall be supplied by the vendor, as listed in this annex.

**L.1.1** The following data shall be identified on transmittal (cover) letters, title pages and correspondence:

- a) purchaser's/owner's corporate name;
- b) job/project number;
- c) equipment item number and service name;
- d) inquiry or purchaser order number;
- e) any other identification specified in the inquiry or purchaser order;
- f) vendor's identifying proposal number, shop order number, serial number, or other reference required to identify return correspondence.

**L.1.2** Each drawing shall have a title block in the lower right-hand corner with the date of certification, identification data specified in L.1.1, revision number and date, and title. Similar information shall be provided on all other documents including subvendor items.

### **L.2 Proposals**

#### **L.2.1 General**

**L.2.1.1** The vendor shall forward the original proposal, with the specified number of copies, to the addressee specified in the inquiry documents.

**L.2.1.2** If specified, the proposal shall include, as a minimum, the data specified in L.2.2 through L.2.4, and a specific statement that the system and all its components are in strict accordance with this standard.

**L.2.1.3** If the equipment or any of its components or auxiliaries are not in strict accordance, the vendor shall include a list that details and explains each deviation.

**L.2.1.4** The vendor shall provide details to enable the purchaser to technically evaluate any proposed alternative designs.

**L.2.1.5** All correspondence shall be clearly identified in accordance with L.1.2.

**L.2.1.6** Clearances less than those required by 6.6.4 and Table 5, shall be stated as exceptions to this standard in the proposal.

## L.2.2 Drawings

**L.2.2.1** The drawings indicated on the vendor drawing and data requirements (VDDR) form in this annex shall be included in the proposal. As a minimum, the following data shall be furnished.

- a) A general arrangement or outline drawing for each major skid or system, showing direction of rotation, size and location of major purchaser connections, overall dimensions, maintenance clearance dimensions, overall weights, erection weights, maximum maintenance weights (indicated for each piece), lifting points, and methods of lifting the assembled machine;
- b) cross-sectional drawings showing the details of the proposed equipment;
- c) schematics of all auxiliary systems, including control, and electrical systems;
- d) bills of materials;
- e) sketches that show methods of lifting the assembled pump, packages, and major components and auxiliaries. [This information may be included on the drawings specified in Item a) above.]

**L.2.2.2** If “typical” drawings, schematics, and bills of material are used, they shall be marked up to show the correct weight and dimension data and to reflect the actual equipment and scope proposed.

## L.2.3 Technical Data for Proposal

**L.2.3.1** All technical data shall be given in units of measurement according to the purchase order. If needed, the technical data in alternate units can be included in parentheses.

**L.2.3.2** The following data shall be included in the proposal.

- a) Purchaser’s data sheets, with complete vendor’s information entered thereon and literature to fully describe details of the offering.
- b) Predicted noise data.
- c) VDDR form (see Figure L.1 for example form), indicating the schedule according to which the vendor agrees to transmit all the data specified.
- d) Schedule for shipment of the equipment, in weeks after receipt of the order.
- e) List of major wearing components, showing interchangeability with other items on the project or the owner’s existing machines.
- f) List of spare parts recommended for start-up and normal maintenance purposes (see Table L.1).
- g) List of the special tools furnished for maintenance (see 7.7.1).
- h) Description of any special weather and winterization required for start-up, operation, and periods of idleness, under the site conditions specified on the data sheets. This description shall clearly indicate the protection to be furnished by the purchaser as well as that included in the vendor’s scope of supply.
- i) Complete tabulation of utility requirements, e.g. steam, water, electricity, and external flush liquid (including the quantity and supply pressure of the liquid required). Approximate data shall be clearly indicated as such.
- j) Description of any optional or additional tests and inspection procedures for materials, as required by 6.12.1.6.

- k) Description of any special requirements whether specified in the purchaser's inquiry or as outlined in 6.1.11, 6.11.13, 6.1.14, 6.1.15, 6.1.24, 6.1.27, 6.1.35, 6.1.36, 6.2.1, 6.6.1, 6.10.1.1, 6.10.1.3, 9.1.3.1, and 9.1.3.6.
- l) List of machines similar to the proposed machine(s) that have been installed and operating under conditions analogous to those in the inquiry.
- m) Any start-up, shutdown, or operating restrictions required to protect the integrity of the equipment.
- n) A list of any components that can be construed as being of alternative design, hence requiring purchaser's acceptance (6.1.1.3).
- o) Component designed for a finite life (6.1.2).
- p) Calculated specific speed and suction-specific speed.
- q) Notification if testing at rated speed, per 8.3.3.3.3, is not possible or recommended. A recommendation for correction of pump power from rated to test conditions shall also be included.

#### **L.2.4 Curves**

The vendor shall provide complete performance curves, including differential head, typical efficiency, water NPSH3, and power expressed as functions of flowrate. The curves shall include the following:

- a) except for low specific-speed designs where it would not be feasible, the curves shall be extended to at least 120 % of flowrate at peak efficiency, and the rated operating point shall be indicated;
- b) the head curve for maximum and minimum impeller diameters shall be included;
- c) the impeller identification number, specific speed, and suction-specific speed shall be shown on the curves;
- d) if applicable, the curves shall indicate viscosity corrections;
- e) minimum flow (both thermal and stable), preferred and allowable operating regions, and any limitations of operation shall be indicated.

#### **L.2.5 Optional Tests**

The vendor shall furnish an outline of the procedures to be used for each of the special or optional tests that have been specified by the purchaser or proposed by the vendor.

### **L.3 Engineering Design Data**

#### **L.3.1 General**

**L.3.1.1** Engineering data shall be furnished by the vendor in accordance with the agreed VDDR form (see Figure L.1 for example form).

**L.3.1.2** The purchaser shall review the vendor's data upon receipt; however, this review shall not constitute permission to deviate from any requirements in the order unless specifically agreed in writing. After the data has been reviewed and accepted, the vendor shall furnish certified copies in the quantities specified.

**L.3.1.3** A complete list of vendor data shall be included with the first issue of major drawings. This list shall contain titles, drawing numbers, and a schedule for transmittal of each item listed. This list shall cross-reference data with respect to the VDDR form.

### **L.3.2 Drawings and Technical Data**

The drawings and data furnished by the vendor shall contain sufficient information so that together with the manuals specified in L.3.5, the purchaser can properly install, operate, and maintain the equipment covered by the purchase order. All contract drawings and data shall be clearly legible (8-point minimum font size even if reduced from a larger size drawing), shall cover the scope of the agreed VDDR form, and shall satisfy the applicable detailed descriptions in this annex.

### **L.3.3 Progress Reports**

The vendor shall submit progress reports to the purchaser at intervals specified that shall, as a minimum, include the following:

- a) overall progress summary,
- b) status of engineering,
- c) status of document submittals,
- d) status of major suborders,
- e) updated production schedule,
- f) inspection/testing highlights for the month,
- g) any pending issues.

### **L.3.4 Parts Lists and Recommended Spares**

**L.3.4.1** The vendor shall submit complete parts lists for all equipment and accessories supplied.

**L.3.4.2** These lists shall include part names, manufacturers' unique part numbers and materials of construction (identified by applicable international standards).

**L.3.4.3** Each part shall be completely identified and shown on appropriate cross-sectional, assembly-type cutaway, or exploded-view isometric drawings.

**L.3.4.4** Interchangeable parts shall be identified as such.

**L.3.4.5** Parts that have been modified from standard dimensions or finish to satisfy specific performance requirements shall be uniquely identified by part number.

**L.3.4.6** The vendor shall indicate on each of these complete parts lists all those parts that are recommended as start-up or maintenance spares, and the recommended stocking quantities of each. These shall include spare parts recommendations of subvendors that were not available for inclusion in the vendor's original proposal. (Sample list is shown in Table L.1 below.)

### **L.3.5 Installation, Operation, Maintenance, and Technical Data Manuals**

#### **L.3.5.1 General**

The vendor shall provide sufficient written instructions and all necessary drawings to enable the purchaser to install, operate, and maintain all of the equipment covered by the purchase order. This information shall be compiled in a manual or manuals with a cover sheet showing the information listed in L.1.2, an index sheet, and a complete list of the enclosed drawings by title and drawing number. The manual pages and drawings shall be

numbered. The manual or manuals shall be prepared specifically for the equipment covered by the purchase order. "Typical" manuals are unacceptable.

**L.3.5.1.1** A draft manual(s) shall be issued to purchaser 8 weeks prior to mechanical testing for review and comment.

**L.3.5.1.2** Refer to the VDDR form for number of copies. Hardcopies as well as electronic copies shall be provided as described on VDDR.

### **L.3.5.2 Installation Manual**

**L.3.5.2.1** All information required for the proper installation of the equipment shall be compiled in a manual that shall be issued no later than the time of issue of final certified drawings. For this reason, it may be separate from the operating and maintenance instructions.

**L.3.5.2.2** This manual shall contain information on alignment and grouting procedures, normal and maximum utility requirements, centers of mass, rigging provisions and procedures, and all other installation data.

**L.3.5.2.3** All drawings and data specified in L.2.2 and L.2.3 that are pertinent to proper installation shall be included as part of this manual [reference L.3.6.1 cc) below for listing].

**L.3.5.2.4** One extra manual, over and above the specified quantity, shall be included with the first equipment shipped.

**L.3.5.2.5** All recommended receiving and storage procedures shall be included.

NOTE Refer to API 686 for data required for installation.

### **L.3.5.3 Operating and Maintenance Manual**

A manual containing all required operating and maintenance instructions shall be supplied at shipment. In addition to covering operation at all specified process conditions, this manual shall also contain separate sections covering operation under any specified extreme environmental conditions.

### **L.3.5.4 Technical Data Manual**

The vendor shall provide the purchaser with a technical data manual at shipment.

Table K.L.1—Recommended Spare Parts

	Number of Pumps with Identical Parts						
	<i>n</i>						
	1 to 3	4 to 6	≥7	1 to 3	4 to 6	7 to 9	≥ 10
	Recommended Number of Spare Parts						
	Start-up			Normal Maintenance			
Cartridge <sup>b e</sup>	—	—	—	1	1	1	1
Element <sup>b f</sup>	—	—	—	1	1	1	1
Rotor <sup>c g</sup>	—	—	—	1	1	1	1
Case <sup>a</sup>	—	—	—	—	—	—	1
Head (case cover and stuffing box)	—	—	—	—	—	—	1
Bearing bracket <sup>a</sup>	—	—	—	—	—	—	1
Shaft (with key)	—	—	—	1	1	2	<i>n</i> /3
Impeller	—	—	—	1	1	2	<i>n</i> /3
Wear rings (set) <sup>h</sup>	1	1	1	1	1	2	<i>n</i> /3
Bearings, complete (rolling element, radial) <sup>a i</sup>	1	1	2	1	2	<i>n</i> /3	<i>n</i> /3
Bearings, complete (rolling element, thrust) <sup>a i</sup>	1	1	2	1	2	<i>n</i> /3	<i>n</i> /3
Bearings, complete (hydrodynamic, radial) <sup>a i</sup>	1	1	2	1	2	<i>n</i> /3	<i>n</i> /3
Bearing pads only (hydrodynamic, radial) <sup>a i</sup>	1	1	2	1	2	<i>n</i> /3	<i>n</i> /3
Bearings, complete (hydrodynamic, thrust) <sup>a i</sup>	1	1	2	1	2	<i>n</i> /3	<i>n</i> /3
Bearing pads only (hydrodynamic, thrust) <sup>a i</sup>	1	1	2	1	2	<i>n</i> /3	<i>n</i> /3
Mechanical seal/packing <sup>d h i</sup>	1	2	<i>n</i> /3	1	2	<i>n</i> /3	<i>n</i> /3
Shaft sleeve <sup>h</sup>	1	2	<i>n</i> /3	1	2	<i>n</i> /3	<i>n</i> /3
Gaskets, shims, O-rings (set) <sup>h</sup>	1	2	<i>n</i> /3	1	2	<i>n</i> /3	<i>n</i> /3
Add for vertical pump:							
Bowls	—	—	—	—	—	<i>n</i> /3	<i>n</i> /3
Spiders or spider bushings (set)	—	—	1	1	1	<i>n</i> /3	<i>n</i> /3
Bearings, bushings (set)	1	1	2	1	1	<i>n</i> /3	<i>n</i> /3
Add for high-speed integral gear:							
Gear box	—	1	1	1	1	1	<i>n</i> /3
Diffuser and cover	1	1	1	1	1	1	<i>n</i> /3
Splined shaft	1	1	1	1	1	1	<i>n</i> /3
Gear-box housing	—	—	—	1	1	1	<i>n</i> /3
Oil pump, internal	—	1	1	1	1	1	<i>n</i> /3
Oil pump, external	—	1	1	1	1	1	<i>n</i> /3
Oil filter	1	2	<i>n</i> /3	1	2	3	<i>n</i> /3

<sup>a</sup> Horizontal pumps only.

<sup>b</sup> Vital-service pumps are generally unspared, partially spared, or multistage. When a vital machine is down, production loss or violation of environmental permits results.

<sup>c</sup> Essential-service pumps are required for operation and have an installed spare. A production loss occurs only if main and spare fail simultaneously.

<sup>d</sup> Cartridge-type mechanical seals include sleeve and gland.

<sup>e</sup> Cartridge consists of assembled element plus discharge head, seal(s), and bearing housing(s).

<sup>f</sup> Element consists of assembled rotor plus stationary hydraulic parts [diffuser(s) or volute(s)].

<sup>g</sup> Rotor consists of all rotating parts attached to the shaft, except the half-coupling.

<sup>h</sup> Normal-wear parts (see 6.1.1).

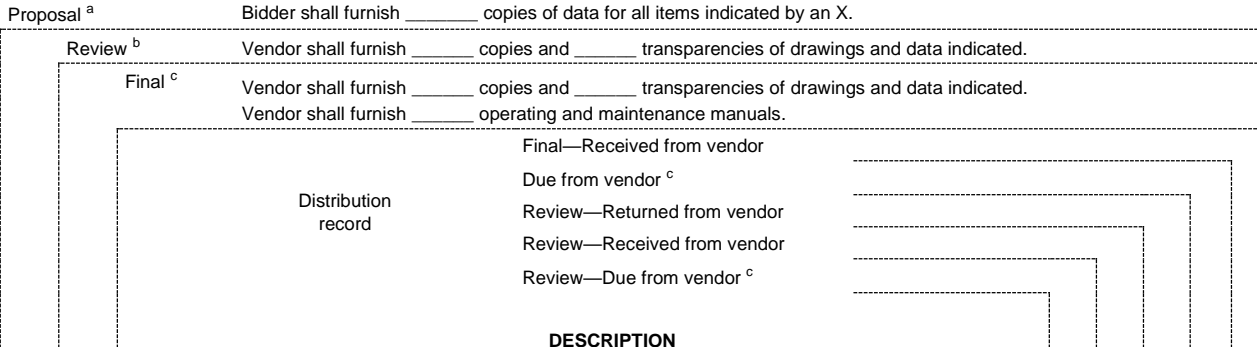
<sup>i</sup> Per pump set.



**TYPICAL  
VENDOR DRAWING AND DATA  
REQUIREMENTS**

JOB NO. \_\_\_\_\_ ITEM NO. \_\_\_\_\_  
 PURCHASE ORDER NO. \_\_\_\_\_ DATE \_\_\_\_\_  
 REQUISITION NO. \_\_\_\_\_ DATE \_\_\_\_\_  
 ENQUIRY NO. \_\_\_\_\_ DATE \_\_\_\_\_  
 PAGE 1 OF 2 BY \_\_\_\_\_  
 REVISION \_\_\_\_\_  
 UNIT \_\_\_\_\_  
 NO. REQUIRED \_\_\_\_\_

FOR \_\_\_\_\_  
 SITE \_\_\_\_\_  
 SERVICE \_\_\_\_\_



**DESCRIPTION**

		<b>Pump</b>						
	a	Certified dimensional outline drawing						
	b	Cross-sectional drawings and bills of materials						
	c	Shaft seal drawing and bills of materials						
	d	Shaft coupling assembly drawing and bill of materials						
	e	Primary and auxiliary flush piping schematics and bills of materials						
	f	Cooling or heating schematic and bill of materials						
	g	Lubricating oil schematic and bill of materials						
	h	Lubricating oil system arrangement drawing						
	i	Lubricating oil component drawings						
	j	Electrical and instrumentation schematics, wiring diagrams, and bills of materials						
	k	Electrical and instrumentation arrangement drawing and list of connections						
	l	Performance curves						
	m	Vibration analysis data						
	n	Damped unbalanced response analysis						
	o	Lateral critical speed analysis						
	p	Torsional critical speed analysis						
	q	Certified hydrostatic test data						
	r	Material certifications						
	s	Progress reports						
	t	Weld procedures						
	u	Performance test data						
	v	Optional test data and reports						
	w	Certified rotor balance data for multistage pumps						
	x	Residual unbalance check						
	y	Rotor mechanical and electrical runout for pumps with noncontacting shaft vibration probes						
	z	Data sheets applicable to proposals, purchase and as-built						
	aa	Noise data sheets						
	bb	As-built clearances						
	cc	Installation, operation, and maintenance manuals						
	dd	Spare parts recommendations and price list						
	ee	Preservation, packaging, and shipping procedures						
	ff	Material safety data sheets						

**Figure L.1—Example Distribution Record**

**TYPICAL  
VENDOR DRAWING AND DATA  
REQUIREMENTS**

JOB NO. \_\_\_\_\_ ITEM NO. \_\_\_\_\_  
 PURCHASE ORDER NO. \_\_\_\_\_ DATE \_\_\_\_\_  
 REQUISITION NO. \_\_\_\_\_ DATE \_\_\_\_\_  
 ENQUIRY NO. \_\_\_\_\_ DATE \_\_\_\_\_

PAGE 2 OF 2 BY \_\_\_\_\_

FOR \_\_\_\_\_  
 SITE \_\_\_\_\_  
 SERVICE \_\_\_\_\_

REVISION \_\_\_\_\_  
 UNIT \_\_\_\_\_  
 NO. REQUIRED \_\_\_\_\_

Proposal <sup>a</sup> Bidder shall furnish \_\_\_\_\_ copies of data for all items indicated by an X.

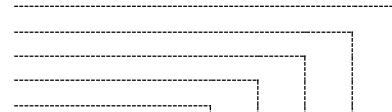
Review <sup>b</sup> Vendor shall furnish \_\_\_\_\_ copies and \_\_\_\_\_ transparencies of drawings and data indicated.

Final <sup>c</sup> Vendor shall furnish \_\_\_\_\_ copies and \_\_\_\_\_ transparencies of drawings and data indicated.

Vendor shall furnish \_\_\_\_\_ operating and maintenance manuals.

**DISTRIBUTION  
RECORD**

Final – Received from vendor  
 Due from vendor <sup>c</sup>  
 Review – Returned from vendor  
 Review – Received from vendor  
 Review – Due from vendor <sup>c</sup>



**DESCRIPTION**

		Motor							
	a	Certified dimensional outline drawing							
	b	Cross-sectional drawing and bill of materials							
	c	Data sheets applicable to proposals, purchase and as-built							
	d	Noise data sheets							
	e	Performance data							
	f	Certified drawings of auxiliary systems							
	g	Installation operation and maintenance manuals							
	h	Spare parts recommendations and price list							
	i	Material safety data sheets							

- <sup>a</sup> It is not necessary that proposal drawings and data be certified or as-built. Typical data shall be clearly identified as such.
- <sup>b</sup> For single-stage units: these items are normally provided only in instruction manuals.
- <sup>c</sup> These items are normally applicable to multistage units only.

Send all drawings and data to \_\_\_\_\_  
 \_\_\_\_\_

All drawings and data shall show project, appropriation, purchase order, and item numbers in addition to the plant location and unit. In addition to the copies specified above, one set of the drawings/instructions necessary for field installation shall be forwarded with the shipment.

Nomenclature:  
 \_\_\_\_\_ S—number of weeks prior to shipment.  
 \_\_\_\_\_ F—number of weeks after firm order.  
 \_\_\_\_\_ D—number of weeks after receipt of approved drawings.

Vendor \_\_\_\_\_  
 Date \_\_\_\_\_ Vendor reference \_\_\_\_\_  
 Signature \_\_\_\_\_

**Figure L.1—Example Distribution Record (Continued)**

## L.3.6 Description of Documents in Figure L.1

### L.3.6.1 Pump

- a) Certified dimensional outline drawing, including the following:
  - 1) size, rating, and location of all purchaser connections;
  - 2) approximate overall and handling masses;
  - 3) overall dimensions, and maintenance and dismantling clearances;
  - 4) shaft centerline height;
  - 5) dimensions of baseplates (if furnished) complete with diameters, number and locations of bolt holes, and the thicknesses of sections through which it is necessary that the bolts pass;
  - 6) grouting details;
  - 7) forces and moments for suction and discharge nozzles;
  - 8) center of gravity and lifting points;
  - 9) shaft end separation and alignment data;
  - 10) direction of rotation;
  - 11) winterization, tropicalization, and/or noise attenuation details, if required.
- b) Cross-sectional drawings and bills of materials.
- c) Shaft seal drawing and bill of materials.
- d) Shaft coupling assembly drawing and bill of materials, including allowable misalignment tolerances and the style of the coupling guard.
- e) Primary and auxiliary sealing schematic and bill of materials, including seal fluid, liquid flows, pressure, pipe and valve sizes, instrumentation, and orifice sizes.
- f) Cooling or heating schematic and bill of materials, including cooling or heating media, liquid flows, pressure, pipe and valve sizes, instrumentation, and orifice sizes.
- g) Lubricating oil schematic and bill of materials, including the following:
  - 1) oil flowrates, temperatures, and pressures at each use point;
  - 2) control, alarm, and trip settings (pressure and recommended temperatures);
  - 3) total head loads;
  - 4) utility requirements, including electricity, water, and air;
  - 5) pipe, valve, and orifice sizes;
  - 6) instrumentation, safety devices, control schemes, and wiring diagrams.
- h) Lubricating oil system arrangement drawing, including size, rating, and location of all purchaser connections.

- i) Lubricating oil component drawings and data, including the following:
  - 1) pumps and drivers;
  - 2) coolers, filters, and reservoir;
  - 3) instrumentation;
  - 4) spare parts lists and recommendations.
- j) Electrical and instrumentation schematics, wiring diagrams, and bills of materials, including the following:
  - 1) vibration alarm and shutdown limits,
  - 2) bearing temperature alarm and shutdown limits,
  - 3) lubricating oil temperature alarm and shutdown limits,
  - 4) driver.
- k) Electrical and instrumentation arrangement drawing and list of connections.
- l) Performance curves.
- m) Vibration analysis data.
- n) Damped unbalanced response analysis.
- o) Lateral critical speed analysis: the required number of lateral critical analysis reports, no later than 3 months after the date of order. The reports shall be as required in I.1.2 and I.1.3.
- p) Torsional critical speed analysis: the required number of torsional critical analysis reports, no later than 3 months after the date of order. The reports shall be as required in 6.9.2.9.
- q) Certified hydrostatic test data.
- r) Material certifications: the vendor's physical and chemical data from mill reports (or certification) of pressure parts, impellers, and shafts.
- s) Progress reports detailing the cause of any delays including engineering, purchasing, manufacturing, and testing schedules for all major components (planned and actual dates, and the percentage completed, shall be indicated for each milestone in the schedule).
- t) Weld procedures.
- u) Performance test data: certified shop logs of the performance test, record of shop test data (which the vendor shall maintain for at least 20 years after the date of shipment); the vendor shall submit certified copies of the test data to the purchaser before shipment.
- v) Optional tests data and reports: optional tests data and reports include NPSH required test, complete unit test, sound level test, auxiliary equipment test, bearing housing resonance test, and any other tests mutually agreed upon by the purchaser and vendor.
- w) Certified rotor balance data for multistage pumps.
- x) Residual unbalance check.

- y) Rotor mechanical and electrical runout for pumps designed to use noncontacting shaft vibration probes.
- z) Data sheets applicable to proposals, purchase, and as-built.
- aa) Noise data sheets.
- bb) As-built clearances.
- cc) Instruction manuals describing installation, operation, and maintenance procedures; each manual shall include the following sections.
  - 1) Section 1—Installation:
    - i) storage;
    - ii) foundation;
    - iii) grouting;
    - iv) setting equipment, rigging procedures, component masses, and lifting diagram;
    - v) alignment;
    - vi) piping recommendations;
    - vii) composite outline drawing for pump/driver train, including anchor-bolt locations;
    - viii) dismantling clearances.
  - 2) Section 2—Operation:
    - i) start-up, including tests and checks before start-up;
    - ii) routine operational procedures;
    - iii) lubricating oil recommendations.
  - 3) Section 3—Disassembly and assembly:
    - i) rotor in pump casing;
    - ii) journal bearings;
    - iii) thrust bearings (including clearance and preload on rolling-element bearings);
    - iv) seals;
    - v) thrust collars, if applicable;
    - vi) allowable wear of running clearances;
    - vii) fits and clearances for rebuilding;
    - viii) routine maintenance procedures and intervals.
  - 4) Section 4—Performance curves, including differential head, efficiency, water NPSH3, and brake horsepower vs flowrate for all operating conditions specified.

- 5) Section 5—Vibration data:
  - i) vibration analysis data,
  - ii) lateral critical speed analysis,
  - iii) torsional critical speed analysis.
- 6) Section 6—As-built data:
  - i) as-built data sheets,
  - ii) as-built clearances,
  - iii) rotor balance data for multistage pumps,
  - iv) noise data sheets,
  - v) performance data.
- 7) Section 7—Drawing and data requirements:
  - i) certified dimensional outline drawing and list of connections;
  - ii) cross-sectional drawing and bill of materials;
  - iii) shaft seal drawing and bill of materials;
  - iv) lubricating oil arrangement drawing and list of connections;
  - v) lubricating oil component drawings and data, and bills of materials;
  - vi) electrical and instrumentation schematics, wiring diagrams, and bills of materials;
  - vii) electrical and instrumentation arrangement drawing and list of connections;
  - viii) coupling assembly drawing and bill of materials;
  - ix) primary and auxiliary seal schematic and bill of materials;
  - x) primary and auxiliary seal piping, instrumentation, arrangement, and list of connections;
  - xi) cooling and heating schematic and bill of materials;
  - xii) cooling or heating piping, instrumentation arrangement, and list of connections;
  - xiii) a generic casing drawing defining casing retirement thickness(es) in critical areas shall be provided. The retirement thickness(es) shall be based on failure to comply with any of the criteria in 6.3.3. and 6.3.4.
- dd) Spare parts recommendations and price list.
- ee) Preservation, packaging, and shipping procedure.
- ff) Material safety data sheets.

**L.3.6.2 Motor**

- a) Certified dimensional outline drawing for motor and all auxiliary equipment, including the following:
  - 1) size, location, and purpose of all purchaser connections, including conduit, instrumentation, and any piping or ducting;
  - 2) ASME rating and facing for any flanged connections;
  - 3) size and location of anchor bolt holes and thicknesses of sections through which bolts must pass;
  - 4) total mass of each item of equipment (motor and auxiliary equipment) plus loading diagrams, heaviest mass, and name of the part;
  - 5) overall dimensions and all horizontal and vertical clearances necessary for dismantling, and the approximate location of lifting lugs;
  - 6) shaft centerline height;
  - 7) shaft end dimensions, plus tolerances for the coupling;
  - 8) direction of rotation.
- b) Cross-sectional drawing and bill of materials, including the axial rotor float.
- c) Data sheets applicable to proposals, purchase, and as-built.
- d) Noise data sheets.
- e) Performance data including the following:
  - 1) for induction motors 200 hp (150 kW) and smaller:
    - i) efficiency and power factor at one-half, three-quarter, and full load,
    - ii) speed-torque curves;
  - 2) for induction motors larger than 200 hp (150 kW) and larger, certified test reports for all test run and performance curves as follows:
    - i) time-current heating curve;
    - ii) speed-torque curves at 70 %, 80 %, 90 %, and 100 % of rated voltage;
    - iii) efficiency and power factor curves from 0 to rated service factor;
    - iv) current vs load curves from 0 to rated service factor;
    - v) current vs speed curves from 0 to 100 % of rated speed.
- f) Certified drawings of auxiliary systems, including wiring diagrams, for each auxiliary system supplied; the drawings shall clearly indicate the extent of the system being supplied by the vendor and the extent being supplied by others.

- g) Motor instruction manuals describing installation, operating, and maintenance procedures. Each manual shall include the following sections.
- 1) Section 1—Installation:
    - i) storage;
    - ii) setting motor, rigging procedures, component masses, and lifting diagram;
    - iii) piping and conduit recommendations;
    - iv) composite outline drawing for motor, including locations of anchor-bolt holes;
    - v) dismantling clearances.
  - 2) Section 2—Operation:
    - i) start-up, including check before start-up;
    - ii) normal shutdown;
    - iii) operating limits, including number of successive starts;
    - iv) lubricating oil recommendations.
  - 3) Section 3—Disassembly and assembly instructions:
    - i) rotor in motor,
    - ii) journal bearings,
    - iii) seals,
    - iv) routine maintenance procedures and intervals.
  - 4) Section 4—Performance data required by L.2.2.1 e).
  - 5) Section 5—Data sheets:
    - i) as-built data sheets,
    - ii) noise data sheets.
  - 6) Section 6—Drawing and data requirements:
    - i) certified dimensional outline drawing for motor and all auxiliary equipment, with list of connections;
    - ii) cross-sectional drawing and bill of materials.
- h) Spare parts recommendations and price list.
- i) Material safety data sheets.



## Annex M (informative)

### Test Data Summary

Figure M.1 shows an example of a test data summary form. Figure M.2 and Figure M.3 show examples of a test curve format in SI units and USC units, respectively. Figure M.4 shows the test points referenced in 8.3.3.4.

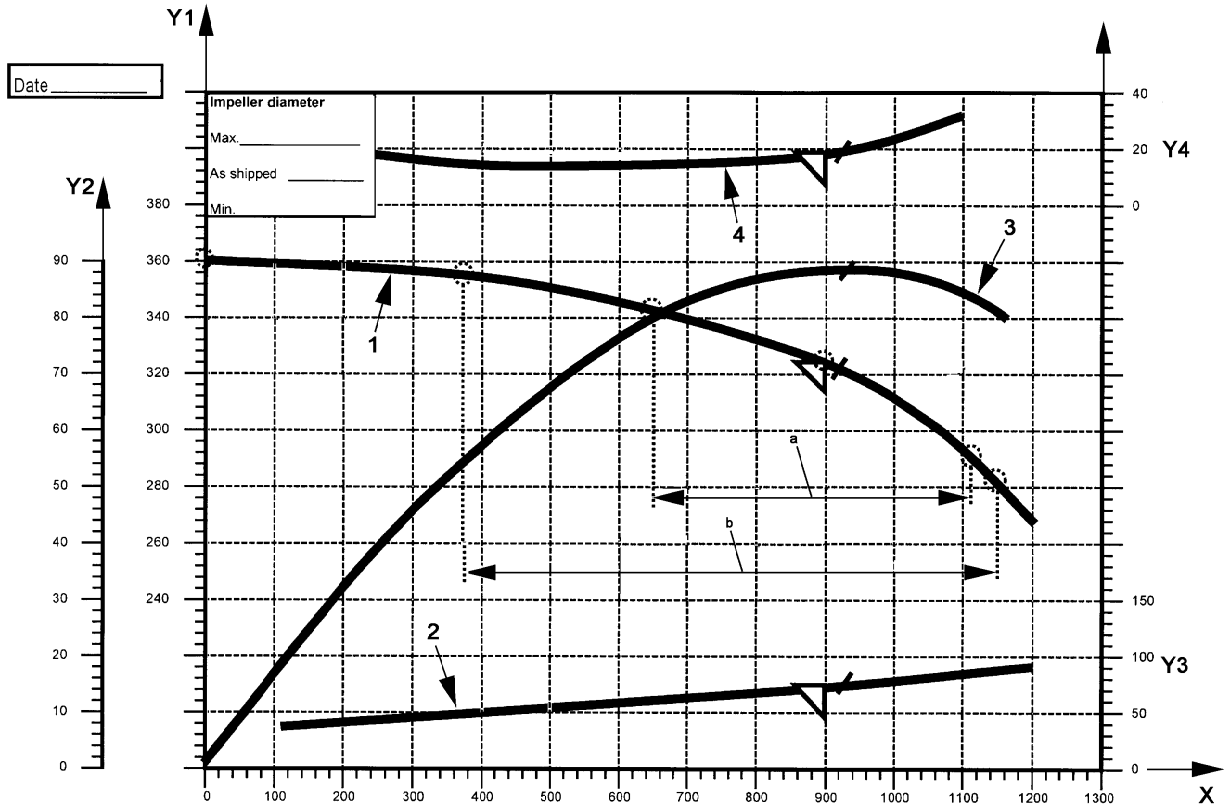
TEST DATA SUMMARY				
Customer		Curve no.		
Purchaser		Test date		
Purchase order no.				
Item no.		Certified by:		
Pump serial no.		(Vendor representative)		
Size and type		Witnessed by:		
No. of stages		(Purchaser representative)		
Overall Pump Performance (Table 16)				
	Rated	Interpolate Value	Actual Deviation ± %	Acceptance Tolerance ± %
Flow				
Head				
Power				
NPSH3				
Shutoff head				
Speed, r/min				
Pump Construction Data				
Stage 1		Series Stages		
Impeller diameter	in. (mm)	Impeller diameter	in. (mm)	
Impeller pattern no.		Impeller pattern no.		
No. of vanes		No. of vanes		
Volute/diffuser pattern no.		Volute/diffuser pattern no.		
Blade tip clearance (6.1.21)	%	Blade tip clearance (6.1.21)	%	

**Figure M.1—Test Data Summary Form**

<b>Mechanical Performance</b>						
<b>Maximum Vibration Levels Recorded Within Specified Flow Region (6.9.3)</b>						
	<b>Rated Flow</b>		<b>Preferred Operating Region</b>		<b>Allowable Operating Region</b>	
	<b>Tested</b>	<b>Specified</b>	<b>Tested</b>	<b>Specified</b>	<b>Tested</b>	<b>Specified</b>
<u>Housing velocity:</u>						
Drive end:						
Overall/filtered						
Nondrive end:						
Overall/filtered						
<u>Shaft displacement:</u>						
Drive end:						
Overall/filtered						
Nondrive end:						
Overall/filtered						
<b>Bearing Temperatures</b> °F (°C) [6.10.2.7, 9.2.5.2.4 c), and 9.2.5.3]						
<b>Pressurized Lubrication Systems</b>			<b>Ring Oil or Splash Lubrication</b>			
Ambient temp.			Ambient temp.			
Oil temp. rise			Oil temp. rise			
Oil return temp.			Oil sump temp.			
Max. bearing metal temp.						
Drive end journal						
Nondrive end journal						
Thrust bearing						
<p>This mechanical performance summary is for recording test levels for each operating region relative to specified values. It is not intended to replace shop test data logs.</p> <p>Units of measurement shall be in./s (mm/s) RMS for velocity, mils (mm) peak/peak for displacement, and °F (°C) for temperature.</p>						

**Figure M.1—Test Data Summary Form (Continued)**

Pump serial no. _____	Pumped liquid _____	<b>Curve No.</b>	Rated point
Size and type _____	Specific gravity _____	Flowrate U.S. gal/min =	900.0
No. of stages _____	Temperature _____ °F	Head ft =	325
Speed, r/min _____	Kinematic viscosity _____ cSt	NPSH3 ft =	17.1
Impeller no. _____	Impeller eye area _____ in. <sup>2</sup>	Power bhp =	72.4
		Calculated efficiency %:	88.3 Ref.

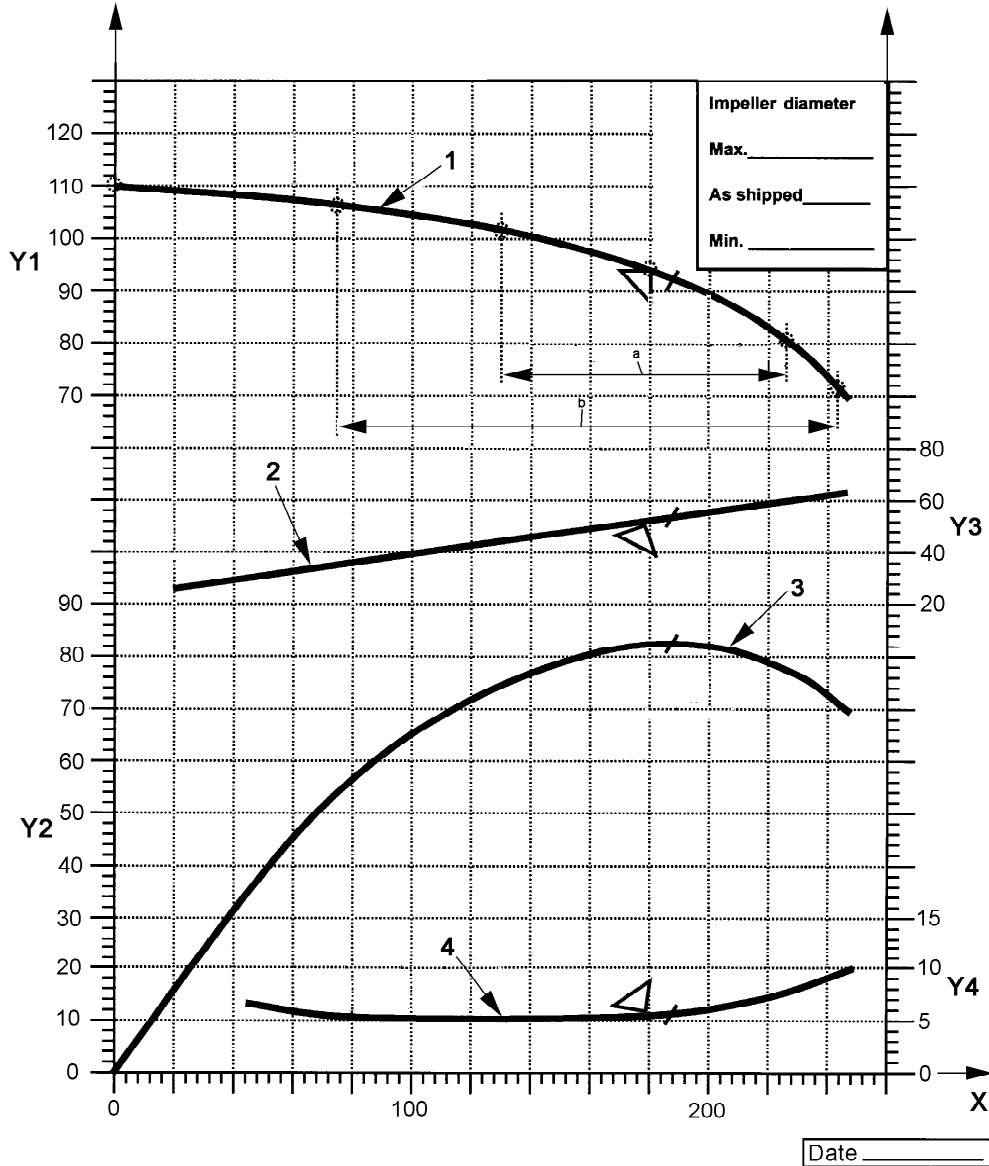


**Key**

- |    |  |   |            |
|----|--|---|------------|
| X  | flowrate, expressed in U.S. gallons per minute | 1 | head       |
| Y1 | head, expressed in feet                        | 2 | power      |
| Y2 | efficiency, expressed in percentage            | 3 | efficiency |
| Y3 | power, expressed in brake horsepower           | 4 | NPSH3      |
| Y4 | NPSH3, expressed in feet                       |   |            |
- a Preferred operating region.  
 b Allowable operating region.

**Figure M.2—Test Curve Format (USC Units)**

Pump serial no. _____	Pumped liquid _____	<b>Curve No.</b>	Rated point
Size and type _____	Relative density _____	Flowrate	m <sup>3</sup> /h = 180.0
No. of stages _____	Temperature _____ °C	Head	m = 94
Speed, r/min _____	Kinematic viscosity _____ mm <sup>2</sup> /s	NPSH3	m = 6.3
Impeller no. _____	Impeller eye area _____ mm <sup>2</sup>	Power	kW = 55.9
		Calculated efficiency %:	82.3 Ref.



**Key**

- X flowrate, expressed in cubic meters per hour
  - Y1 head, expressed in meters
  - Y2 efficiency, expressed in percentage
  - Y3 power, expressed in kilowatts
  - Y4 NPSH3, expressed in meters
  - 1 head
  - 2 power
  - 3 efficiency
  - 4 NPSH3
- a Preferred operating region.  
 b Allowable operating region.

NOTE Values for scales, flow, head, NPSH3, and power efficiency are for illustration only.

**Figure M.3—Example of Test Curve Format (SI Units)**

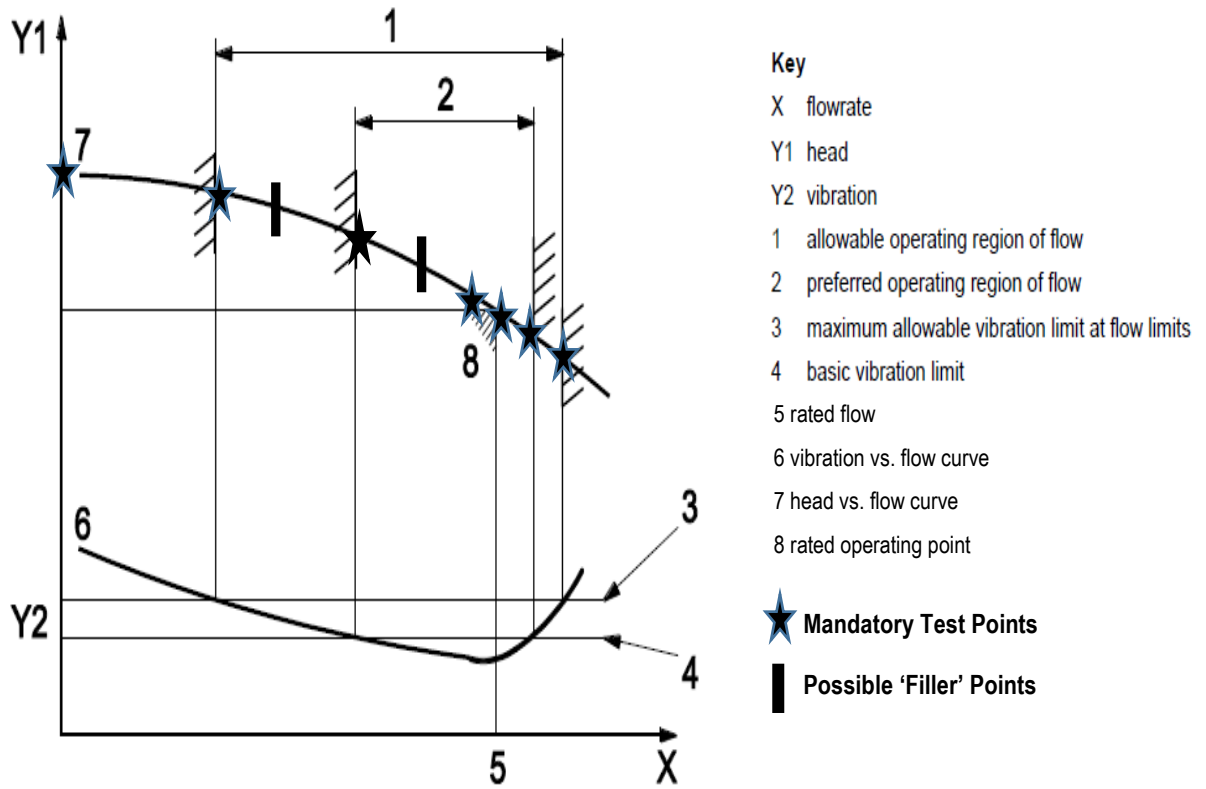


Figure M.4—Test Points Shown on Typical Performance Curve

## **Annex N** (informative)

### **Pump Data Sheets and Electronic Data Exchange**

#### **N.1 Pump Data Sheets**

This annex contains typical data sheets for use by the purchaser and the vendor as shown in Figure N.1 and Figure N.2. The data sheets, in both USC and SI units, are available as Microsoft Excel Spreadsheets. A data element list (see Figure N.3) is provided as an alternative format to capture design data. Figure N.4 contains the API Project Design Data Sheet, which summarizes the Site Design Conditions and Site Utilities. These documents can be combined as-needed to fully define the scope of the pump design requirements.

#### **N.2 Electronic Data Exchange**

The information contained in pump data sheets can also be transmitted digitally rather than via a conventional data sheet format. This is suitable if the pump purchaser and the pump vendor have systems that can process digital information rather than paper-based data sheets. Direct electronic transfer can be achieved with a transfer protocol that is adopted by both the purchaser and vendor. It is necessary that this transfer protocol also be commercially neutral for it to be accepted by all parties. Such a method improves the operating efficiencies of both parties if their internal data systems can import/export via this neutral protocol. Examples of these systems include

a) for the purchaser:

- 1) pump specifications database,
- 2) bid tab program,
- 3) system analysis program,
- 4) as-built asset management program;

b) for the vendor:

- 1) pump selection system,
- 2) pump configuration and quotation development system,
- 3) order management system and bill-of-material management system.

Those interested in utilizing electronic data exchange (EDE) are encouraged to reference the EDE technology and implementation standard, HI 50.7. This standard provides implementation details and examples toward adopting EDE that is suitable for API 610 centrifugal pump data. Additional interpretive information is also available at [www.pumps.org/ede](http://www.pumps.org/ede).

HI 50.7 was developed and supported by the Hydraulic Institute and the FIATECH automating equipment information exchange (AEX) project, in cooperation with the API. Information on the EDE technology and XML schemas is available on line at [www.pumps.org/ede](http://www.pumps.org/ede).

A complete listing of all data fields in the electronic data sheets and their corresponding XML structures are found in HI 50.7 [www.pumps.org/ede](http://www.pumps.org/ede). These data fields are also partially listed in the data list in Figure N.3.

CLIENT: \_\_\_\_\_

PROJECT TITLE: \_\_\_\_\_

JOB NUMBER: \_\_\_\_\_

EQUIPMENT NUMBER: \_\_\_\_\_

EQUIPMENT SERVICE: \_\_\_\_\_

SERIAL NUMBER: \_\_\_\_\_

REQ / SPEC NUMBER : \_\_\_\_\_

PURCHASE ORDER NUMBER : \_\_\_\_\_

Cells coloured thus  contain drop-down options  
 Text in BLACK color are by Purchaser  
 Text in BLUE color are by Supplier  
 Text in RED color are by Purchaser OR Supplier

COMMENTS: \_\_\_\_\_  
 \_\_\_\_\_  
 \_\_\_\_\_  
 \_\_\_\_\_  
 \_\_\_\_\_  
 \_\_\_\_\_  
 \_\_\_\_\_  
 \_\_\_\_\_

ADDITIONAL / RELATED DATASHEETS					
ITEM / TAG NUMBERS	ATT	ITEM / TAG NUMBERS	ATT	ITEM / TAG NUMBERS	ATT
PUMP(s)					
MOTOR(s)					
GEAR(s)					
TURBINE(s)					

APPLICABLE OVERLAY STANDARDS \_\_\_\_\_

Rev	Date	Description	By	Checked			

	<b>CENTRIFUGAL PUMP DATASHEET</b>	DATASHEET No.
		Sheet _____ of _____

Figure N.1—USC Units Pump Process Data Sheet

CENTRIFUGAL PUMP DATASHEET							
<b>GENERAL</b>							
1	Note	APPLICABLE TO: _____	APPLICABLE NATIONAL / INTERNATIONAL STANDARD: _____				Rev
2	CLIENT	_____		UNIT	_____		
3	SITE	_____		SERVICE	_____		
4	NO. REQ	PUMP SIZE	_____	TYPE	_____	No. STAGES	_____
5	MANUFACTURER	_____		MODEL	_____	SERIAL NO.	_____
6	EQUIPMENT NUMBER	_____					
7							
<b>LIQUID CHARACTERISTICS</b>							
9		Units	@ RATED TEMP	@ MAXIMUM TEMP	@ MINIMUM TEMP	Alternate LIQUID	
10	LIQUID TYPE OR NAME	_____	_____	_____	_____	_____	
11	PUMPING TEMPERATURE	*F	_____	_____	_____	_____	
12	VAPOR PRESSURE	psia	_____	_____	_____	_____	
13	RELATIVE DENSITY (3.1.52)	_____	_____	_____	_____	_____	
14	SPECIFIC HEAT	Btu/(lbm*F)	_____	_____	_____	_____	
15	VISCOSITY	cP	_____	_____	_____	_____	
16							
<b>OPERATING CONDITIONS (5.1.3)</b>							
18		Units	Rated	Normal	All Condition 1	All Condition 2	All Condition 3
19					(Name 1)	(Name 2)	(Name 3)
20	NPSHA Datum:	_____					
21	PUMPING TEMPERATURE	*F	_____	_____	_____	_____	_____
22	FLOW	gpm	_____	_____	_____	_____	_____
23	DISCHARGE PRESSURE (5.3.2)	psia	_____	_____	_____	_____	_____
24	SUCTION PRESSURE	psia	_____	_____	_____	_____	_____
25	DIFFERENTIAL PRESSURE	psi	_____	_____	_____	_____	_____
26	DIFFERENTIAL HEAD	ft	_____	_____	_____	_____	_____
27	NPSHA	ft	_____	_____	_____	_____	_____
28	HYDRAULIC POWER	HP	_____	_____	_____	_____	_____
29							
31	SERVICE (CONTINUOUS/INTERMITTENT):	_____		INSTALLATION LOCATION:	_____		
32	* IF INTERMITTENT, NO. OF STARTS:	_____		IF INDOOR, TEMPERATURE: MAX:	_____ *F	MIN:	_____ *F
33	PUMPS OPERATE IN:	_____		ELECTRIC AREA CLASSIFICATION (5.1.28):	_____		
34	CORROSION DUE TO: (5.12.1.9)	_____		DIVISION	_____	ZONE	_____
35	EROSION DUE TO: (5.12.1.9)	_____		GROUP	_____		
36	H2S CONCENTRATION (ppm): (5.12.1.13)	_____		TEMP CLASS	_____		
37	CHLORIDE CONCENTRATION (ppm):	_____		PUMP VALVE START POSITION:	_____		
38	PARTICULATE SIZE (DIA IN MICRONS)	_____					
39	PARTICULATE CONCENTRATION (ppm)	_____					
40	CORROSION ALLOWANCE (5.3.10):	_____					
41	DESIGN NOTES:	_____					
42							
44							
<b>PERFORMANCE</b>				<b>DRIVER (7.1)</b>			
46	PROPOSAL CURVE NO.	_____	RPM	_____	DRIVER TYPE	_____	
47	IMPELLER DIA: RATED	_____	MAX.	_____	MIN.	_____	_____
48	RATED POWER:	_____	HP	EFFICIENCY	_____	(%)	_____
49	RATED CURVE BEP FLOW (at rated impeller diameter) (5.1.16):	_____		gpm	_____	_____	_____
50	MIN FLOW:	_____	_____	STABLE	_____	_____	_____
51	PREFERRED OPERATING REGION (5.1.16)	_____	to	_____	gpm	_____	_____
52	ALLOWABLE OPERATING REGION (5.9.4.1)	_____	to	_____	gpm	_____	_____
53	MAX HEAD @ RATED IMPELLER	_____		ft	_____	_____	_____
54	MAX POWER @ RATED IMPELLER	_____		HP	_____	_____	_____
55	NPSH3 AT RATED FLOW (5.1.9):	_____		ft	_____	_____	_____
56	CENTERLINE OF PUMP TO NPSHA DATUM	_____		ft	_____	_____	_____
57	NPSH MARGIN AT RATED FLOW (5.1.10):	_____		ft	_____	_____	_____
58	SPECIFIC SPEED (5.1.17)	_____	gpm/psia <sup>1/2</sup> ft	_____	RADIAL	_____	_____
59	SUCTION SPECIFIC SPEED LIMIT (5.1.11)	_____	gpm/psia <sup>1/2</sup> ft	_____	THRUST	_____	_____
60	SUCTION SPECIFIC SPEED (5.1.11)	_____	gpm/psia <sup>1/2</sup> ft	_____	STARTING METHOD	_____	_____
61	MAX. ALLOWABLE SOUND PRESSURE LEVEL (5.1.19)	_____	(dBA)	_____	DRIVER DATASHEET NUMBER	_____	_____
62	ESTIMATED MAX. SOUND PRESSURE LEVEL	_____	(dBA)	_____	DRIVE DESIGN STANDARD	_____	_____
63	MAX. ALLOWABLE SOUND POWER LEVEL (5.1.19)	_____	(dB)	_____			
64	ESTIMATED MAX SOUND POWER LEVEL	_____	(dB)	_____			
65							
DATASHEET No. _____				Rev: _____ SHEET _____ of _____			

Figure N.1—USC Units Pump Process Data Sheet (Continued)



CENTRIFUGAL PUMP DATASHEET		CONSTRUCTION	Rev
1	Note		
2	API PUMP TYPE (Table 1):	CASING MOUNTING (6.3.14, 9.3.8.3):	
3		CASING TYPE:	
4	NOZZLE CONNECTIONS (6.4.2):	OH3 BACK-PULLOUT LIFTING DEVICE REQD. (9.1.2.6)	
5		CASING PRESSURE RATING:	
6	SUCTION	MAWP (6.3.6):	_____ psig @ _____ °F
7	DISCHARGE	HYDROTEST (6.3.2.2):	_____ psig @ _____ °F
8	PRESSURE CASING AUX. CONNECTIONS: (6.4.3)	WETTING AGENT REQUIRED FOR HYDROTEST (6.3.2.7):	
9		HYDROTEST OH PUMP ASSEMBLY (6.3.2.14):	
10	BALANCE/LEAK OFF	SUCT'N PRESS. REGIONS DESIGNED FOR MAWP (6.3.8):	
11	DRAIN		
12	VENT	ROTOR:	
13	PRESSURE GAGE	SHAFT FLEXIBILITY INDEX (SFI) (9.1.1.3)	
14	TEMP GAGE	FIRST CRITICAL SPEED WET (MULTISTAGE PUMPS ONLY)	
15	WARM-UP LINE	COMPONENT BALANCE TO ISO 1940-1, G1 (6.9.3.4):	
16		SHRINK-FIT-LIMITED MOVEMENT IMPELLERS (9.2.2.3)	
17	DRAIN VALVE SUPPLIED BY (7.6.2.5)	ROTATION (VIEWED FROM COUPLING END):	
18	DRAINS MANIFOLDED (7.6.2.5)	IMPELLERS INDIVIDUALLY SECURED (6.6.3):	
19	VENT VALVE SUPPLIED BY		
20	VENTS MANIFOLDED	COUPLING: (7.2)	
21	THREADED CONS FOR PIPELINE SERVICE & < 55°C (6.4.3.2)	MANUFACTURER	
22	SPECIAL FITTINGS FOR TRANSITIONING (6.4.3.3)	MODEL	
23	CYLINDRICAL THREADS REQUIRED (6.4.3.2)	RATING ( HP / 100 RPM )	
24	MACHINED AND STUDDED AUX CONNECTIONS (6.4.3.6)	SPACER LENGTH (7.2.2.d)	_____ in
25	ROUTE DRAIN TO SKID EDGE	SERVICE FACTOR (7.2.3)	
26		RIGID-TYPE	
27		COUPLING WITH HYDRAULIC FIT (7.2.9)	
28	MATERIAL (6.12.1.1)	COUPLING WITH PROPRIETARY CLAMPING DEVICE (7.2.10)	
29	ANNEX H CLASS	COUPLING IN COMPLIANCE WITH (7.2.4)(7.2.2.f)	
30	MINIMUM DESIGN METAL TEMPERATURE (6.12.4.1)	GUARDS (7.3)	
31	MAXIMUM ALLOWABLE TEMPERATURE (3.1.20)	COUPLING AND SHAFT GUARD STANDARD (7.3)	
32	REDUCED-HARDNESS MATERIALS REQ'D (6.12.1.14)	IGNITION HAZARD ASSESSMENT PER EN 13463-1 (7.3.2.2; 7.3.3.4)	
33	APPLICABLE HARDNESS STANDARD (6.12.1.14)	COUPLING GUARD MATERIAL (7.3.2.1; 7.3.3.3):	
34	BARREL:	SHAFT GUARD MATERIAL (7.3.2.1; 7.3.3.3):	
35	CASE:	SPARK RESISTANT MATERIAL REQUIRED (7.3.2.1):	
36	DIFFUSERS		
37	IMPELLER:	BASEPLATE	
38	IMPELLER WEAR RING:	API BASEPLATE NUMBER (ANNEX D):	
39	CASE WEAR RING:	IF NON-STD BASEPLATE DIMENSIONS (LxW) ( in <sup>2</sup> ):	
40	SHAFT:	BASEPLATE CONSTRUCTION (7.4)	
41	BOWL (IF VS-TYPE)	BASEPLATE DRAINAGE (7.4.1)	
42		MOUNTING:	
43		NON-GROUT CONSTRUCTION (7.4.1.e):	
44	BEARINGS AND BEARING HOUSINGS (6.10.1)	SUPPLIED WITH:	
45	BEARING (TYPE / NUMBER):	● GROUT AND VENT HOLES	
46	RADIAL	● DRAIN CONNECTION	
47	THRUST		
48	REVIEW AND APPROVE THRUST BEARING SIZE: (9.2.5.2.6)	DEMONSTRATE BASEPLATE PAD FLATNESS (7.4.9)	
49	LUBRICATION (6.11.3) (9.3.12.4):	PROVIDE SPACER PLATE UNDER ALL EQUIPMENT FEET (7.4.10)	
50	PRESSURE LUBE SYSTEM TO API-614, CHAPTER:	BOLT OH 3/4/5 PUMP TO PAD / FOUNDATION:	
51	API 614 DATASHEETS ATTACHED (9.2.6.4)	PROVIDE SOLEPLATE FOR OH 3/4/5 PUMPS (9.1.2):	
52	PRESSURIZED LUBE OIL SYSTEM MOUNTED ON BASEPLATE:		
53	LOCATION OF PRESSURIZED LUBE OIL SYSTEM:		
54	INTERCONNECTING PIPING PROVIDED BY		
55	OIL VISC. ISO GRADE		VG
56	VENT-TO-HOUSING CONSTANT LEVEL OILER (6.10.2.4):		
57	OIL MIST PROVISIONS (6.11.3)		
58	GREASE LUBRICATION (6.11.4)		
DATASHEET No. _____		Rev: _____	SHEET _____ of _____

Figure N.1—USC Units Pump Process Data Sheet (Continued)

CENTRIFUGAL PUMP DATASHEET				
1	Note	INSTRUMENTATION	SEAL SUPPORT SYSTEM MOUNTING	Rev
2		INSTRUMENTATION PER API-670 (7.5.2)	MOUNTED ON PUMP BASEPLATE (7.6.1.4)	
3		ACCELEROMETERS (7.5.2.1)	LOCATION ON OR OFF BASEPLATE (7.4.6) :	
4		NUMBER OF ACCELEROMETERS _____	INTERCONNECTING PIPING BY _____	
5		MOUNTING LOCATION: _____		
6		PROVISION FOR MTG ONLY (6.10.2.13)		
7		FLAT SURFACE REQUIRED (6.10.2.14)		
<b>MECHANICAL SEAL (6.8)</b>				
8			API 682 DATASHEET ATTACHED :	
9		VIBRATION PROBES (7.5.2.2)	ADDITIONAL CENTRAL FLUSH PORT (6.8.9)	
10		VIBRATION PROBES REQUIRED (7.5.2.2)	HEATING JACKET REQ'D. (6.8.11)	
11		NUMBER PER RADIAL BEARING _____		
12		NUMBER PER AXIAL BEARING _____		
<b>HEATING AND COOLING (6.1.23-6.1.27)</b>				
13		THREADED PROVISION FOR MTG ONLY (6.10.2.13; 6.6.12)	COOLING REQ'D	
14		FLAT SURFACE PROVISION ONLY (6.10.2.14)	COOLING WATER PIPING PLAN (7.6.3.1)	
15		MONITORS AND CABLES SUPPLIED BY (7.5.2.4)	COOLING WATER PIPING	
16			FITTINGS	
17		TEMPERATURE DETECTORS (7.5.2.3)	COOLING WATER PIPING MATERIALS	
18		TEMP. PROBES REQUIRED (7.5.2.3)	COOLING WATER REQUIREMENTS: SUPPLY PRESSURE _____ psig	
19		PROVISIONS FOR MOUNTING ONLY (6.10.2.2)	BEARING HOUSING _____ gpm	
20		RADIAL BEARING TEMP. _____	HEAT EXCHANGER _____ gpm	
21		NUMBER PER RADIAL BEARING _____	TOTAL COOLING WATER _____ gpm	
22		THRUST BEARING TEMP. _____		
23		NUMBER PER THRUST BEARING ACTIVE SIDE _____	HEATING MEDIUM _____	
24		NUMBER PER THRUST BEARING INACTIVE SIDE _____	HEATING PIPING _____	
25		TEMP. GAUGES (WITH THERMOWELLS) (9.1.3.5)		
26		TEMP. GAUGE LOCATION _____		
27		SUPPLY UPPER/LOWER CASING RTD'S FOR WARMUP		
28				
29		PRESSURE GAUGE TYPE _____		
30		PRESSURE GAUGE LOCATION _____		
31				
32				
<b>PIPING &amp; APPURTENANCES</b>				
33			TAG ALL ORIFICES (7.6.2.4)	
34			SOCKET WELD UNION ON 1st SEAL GLAND NIPPLE (7.6.2.8)	
35			MANIFOLD AUX PIPING SYSTEMS AT SKID EDGE (7.6.1.6)	
<b>PRESSURE VESSEL DESIGN CODE REFERENCES</b>				
<u>THESE REFERENCES SHALL BE PROVIDED BY THE MANUFACTURER</u>				
36		CASTING FACTORS USED IN DESIGN (PER TABLE 4)		
37		SOURCE OF MATERIAL PROPERTIES (6.3.5)		
<b>WELDING AND REPAIRS (6.12.3.1)</b>				
<u>THESE REFERENCES SHALL BE PROVIDED BY THE PURCHASER. (DEFAULT TO TABLE 11 IF NO PURCHASER PREFERENCE IS STATED)</u>				
38		ALTERNATIVE WELDING CODES AND STANDARDS		
39		WELDING REQUIREMENT (APPLICABLE CODE OR STANDARD)		
40		ALTERNATIVE WELDER/OPERATOR QUALIFICATION STANDARD		
41		ALTERNATIVE WELDING PROCEDURE QUALIFICATION STANDARD		
42		NON-PRESSURE RETAINING STRUCTURAL WELDING STANDARD (BASEPLATES OR SUPPORTS)		
43		STANDARD FOR MAGNETIC PARTICLE OR LIQUID PENETRANT EXAMINATION (PLATE EDGES)		
44		STANDARD FOR POSTWELD HEAT TREATMENT		
45		STANDARD FOR POSTWELD HEAT TREATMENT OF CASING FABRICATION WELDS		
46				
<b>MATERIAL INSPECTION</b>				
<u>THESE REFERENCES SHALL BE PROVIDED BY THE PURCHASER.</u>				
47		DEFAULT TO TABLE 14	TABLE 14 INSPECTION CLASS:	
48		ALTERNATIVE MATERIAL INSPECTIONS AND ACCEPTANCE CRITERIA (SEE TABLE 15, 8.2.2.5)		
49				
50				
51				
52				
53				
54				
55				
56				
57				
58				
59				
60				

DATASHEET No. \_\_\_\_\_ Rev: \_\_\_\_\_ SHEET \_\_\_\_\_ OF \_\_\_\_\_

Figure N.1—USC Units Pump Process Data Sheet (Continued)

CENTRIFUGAL PUMP DATASHEET							Rev
1	Note	SURFACE PREPARATION, PAINT & SPARES				TEST	
2	MANUFACTURER'S STANDARD (8.4.3.4)					SHOP INSPECTION (8.1.1.1)	
3	OTHER (SEE BELOW)					PERF. CURVE & DATA APPROVAL REQ'D PRIOR TO SHIPMENT (8.3.3.4.6) :	
4	SPECIFICATION NO. _____					<b>TEST WITH SUBSTITUTE SEAL (8.3.3.3.1)</b>	
5	<b>PUMP:</b>					MATERIAL CERTIFICATION REQUIRED (6.12.1.8): CASING	
6	PUMP SURFACE PREPARATION					IMPELLER	
7	PRIMER					SHAFT	
8	FINISH COAT					OTHER _____	
9	<b>BASEPLATE:</b>					CASTING REPAIR WELD PROCEDURE APPROVAL REQ'D (6.12.2.5):	
10	SURFACE PREPARATION					<b>INSPECTION REQUIRED FOR CONNECTION WELDS (6.12.3.4)</b>	
11	PRIMER:					MAG PARTICLE	
12	FINISH COAT					RADIOGRAPHY	
13	UNDERSIDE					LIQUID PENETRANT	
14						ULTRASONIC	
15	<b>SHIPMENT: (8.4)</b>					HARDNESS TEST REQUIRED (6.12.1.14; 8.2.2.7)	
16	EXPORT BOXING REQUIRED					ADDITIONAL SUBSURFACE EXAMINATION (6.12.1.6) (8.2.1.3)	
17	PREPARE FOR OUTDOOR STORAGE (NUMBER OF MONTHS): _____					FOR: _____	
18						METHOD: _____	
19	<b>SPARE ROTOR ASSEMBLY PACKAGED FOR:</b>					PMI TESTING REQUIRED (8.2.2.8)	
20	ROTOR STORAGE ORIENTATION (9.2.8.2)					COMPONENTS TO BE TESTED: _____	
21	SHIPPING & STORAGE CONTAINER SUITABLE FOR					RESIDUAL UNBALANCE TEST (J.4.1.2)	
22	VERTICAL STORAGE (9.2.8.3): _____					NOTIFICATION OF SUCCESSFUL PERFORMANCE TEST (8.1.1.3) (8.3.3.4.6)	
23	N2 PURGE REQUIRED (9.2.8.4): _____					BASEPLATE (NOZZLE LOAD) TEST (7.4.24)	
24						HYDROSTATIC TEST (8.3.2)	
25	<b>SPARE PARTS (10.3.4.2)</b>					HYDROSTATIC TEST OF BOWLS & COLUMN (9.3.13.1)	
26	START-UP					PERFORMANCE TEST (8.3.3)	
27	NORMAL MAINTENANCE					RETEST ON SEAL LEAKAGE (8.3.3.2)	
28						TEST DATA POINTS TO (8.3.3.4)	
29						ALTERNATE TEST TOLERANCES PER (8.3.3.5)	
30						NPSH (8.3.4.3)	
31						NPSH BASED ON 1ST STG ONLY ALLOWED (8.3.4.3.2)	
32						TEST NPSHA LIMITED TO 110% SITE NPSHA (8.3.3.7)	
33						RETEST REQUIRED AFTER FINAL HEAD ADJUSTMENT (8.3.3.8.2)	
34						COMPLETE UNIT TEST (8.3.4.4.1)	
35						SOUND LEVEL TEST (8.3.4.5)	
36						CLEANLINESS PRIOR TO FINAL ASSEMBLY (8.2.2.6)	
37	<b>OTHER PURCHASER REQUIREMENTS</b>					LOCATION OF CLEANLINESS INSPECTION: _____	
38	COORDINATION MEETING REQUIRED					CHECK FOR CO-PLANAR MOUNTING PAD FLATNESS (7.4.8)	
39	MAXIMUM DISCHARGE PRESSURE TO INCLUDE (6.3.2)					MECHANICAL RUN TEST UNTIL OIL TEMP STABLE (8.3.4.2.1)	
40	MAX RELATIVE DENSITY					4 HR. MECH RUN AFTER OIL TEMP STABLE (8.3.4.2.2)	
41	OPERATION TO TRIP SPEED					BRG HSG RESONANCE TEST (8.3.4.7)	
42	MAX DIA. IMPELLERS AND/OR NO OF STAGES					STRUCTURAL RESONANCE TEST (9.3.9.2)	
43	CONNECTION DESIGN APPROVAL (9.2.1.4)					REMOVE / INSPECT HYDRODYNAMIC BEARINGS AFTER TEST (9.2.7.4)	
44	<b>TORSIONAL ANALYSIS / REPORT (6.9.2)</b>					AUXILIARY EQUIPMENT TEST (8.3.4.6)	
45	PROGRESS REPORTS (L.3.3)					EQUIPMENT TO BE INCLUDED IN AUXILIARY TESTS: _____	
46	OUTLINE OF PROCEDURES USED FOR OPTIONAL TESTS (L.2.5)					LOCATION OF AUXILIARY EQUIPMENT TEST: _____	
47	ADDITIONAL DATA REQUIRING 20 YEARS RETENTION (8.2.1.1)						
48	LATERAL ANALYSIS REQUIRED (9.2.4.1.2)						
49	ROTOR DYNAMIC BALANCE TO 4W/N (6.9.3.5)					<b>IMPACT TEST (6.12.4.3) PER EN 13445</b>	
50	VFD STEADY STATE FORCED RESPONSE ANALYSIS (6.9.2.3)					<b>PER ASME SECTION VIII</b>	
51	TRANSIENT FORCED RESPONSE (6.9.2.4)					CASING DISASSEMBLY AFTER TEST (8.3.3.9)	
52	BEARING LIFE CALCULATIONS REQUIRED (6.10.1.11)					SPARE PARTS TEST (8.3.4.8)	
53	CASING RETIREMENT THICKNESS DRAWING [L.3.6.1 cc) 7) xiii]						
54	CONNECTION BOLTING (7.6.1.7)						
55	VENDOR TO KEEP REPAIR AND HT RCDS (8.2.1.1.c)						
56	VENDOR SUBMIT TEST PROCEDURES (8.3.1.1)						
57	SUBMIT INSPECTION CHECK LIST (8.1.5)						
58	ACOUSTIC ANALYSIS OF CROSSOVER PASSAGE (BB3, BB5)(9.2.1.5)						
59	API-691 DOCUMENTATION REQUIRED (6.1.3.1)						
60							
DATASHEET No. _____							Rev: _____
							SHEET _____ OF _____

Figure N.1—USC Units Pump Process Data Sheet (Continued)

VERTICAL PUMP SUPPLEMENTAL DATASHEET			
1	Note	VERTICAL PUMP TYPE (Table 1) _____	Rev
2	REMARKS	_____	
3		_____	
4		_____	
VERTICAL PUMPS		VERTICAL PUMPS (CONTD)	
6	<b>PUMP THRUST:</b>	(+) UP      (-) DOWN	<b>LINE SHAFT:</b>
7	STATIC THRUST	_____ lbf      _____ lbf	LINE SHAFT DIAMETER _____ in
8	AT MIN FLOW	_____ lbf      _____ lbf	TUBE DIAMETER _____ in
9	AT RATED FLOW	_____ lbf      _____ lbf	LINESHAFT CONNECTION _____
10	AT MAX FLOW	_____ lbf      _____ lbf	LEVEL CONTROL _____
11	MAX THRUST	_____ lbf      _____ lbf	SUCTION STRAINER TYPE _____
12	SEPARATE SOLEPLATE REQUIRED (9.3.8.3.2)	_____	IMPELLER COLLETS ACCEPTABLE (6.6.3) _____
13	SOLEPLATE Length x Width	_____ in X _____ in	HARDENED SLEEVES UNDER BEARINGS (9.3.10.4) _____
14	SOLEPLATE THICKNESS	_____ in	STRUCTURAL ANALYSIS (9.3.5) _____
15	SEPARATE MOUNTING FLANGE REQUIRED (9.3.8.3.1)	_____	
16			
17	<b>COLUMN PIPE:</b>	_____	<b>SUCTION CAN</b>
18	DIAMETER	_____ in	THICKNESS _____ in
19	TOTAL COLUMN LENGTH	_____ ft	LENGTH _____ ft
20	NUMBER OF SECTIONS	_____	DIAMETER _____ in
21	SPACING (LENGTH PER SECTION)	_____ ft	CAN DRAIN PIPED TO SURFACE (9.3.13.4) _____
22			ELLIPTICAL BOTTOM HEAD REQUIRED (9.3.2.5) _____
23	<b>GUIDE BUSHINGS:</b>		PRESSURE CASING WALLS USING SEAMLESS PIPE (9.3.2.7) _____
24	NUMBER	_____	HYDROTEST BOWLS/COLUMN @ MAX DIFF PRESSURE (9.3.13.1) _____
25	LINE SHAFT BEARING SPACING	_____ in	
26	GUIDE BUSHING LUBE:	_____	
27			
<b>MATERIALS (additional)</b>			
29	SUCTION CAN / BARREL:	_____	LINESHAFT SLEEVES: _____
30	DISCHARGE HEAD:	_____	BEARING RETAINER: _____
31	BOWL SHAFT:	_____	SHAFT ENCLOSING TUBE: _____
32	LINESHAFT:	_____	DISCHARGE COLUMN: _____
33	LINESHAFT HARDFACING:	_____	PRESSURE RATING: _____
34	BELLMOUTH:	_____	MAWP ( psig)      HYDRO ( psig)
35	BOWL BEARING:	_____	HEAD _____
36	LINESHAFT BEARING:	_____	COLUMN PIPE _____
			BOWL _____
<b>SUMP ARRANGEMENT</b>			
38	<b>SUMP DIMENSIONS:</b>		
39	GRADE ELEVATION	1 _____ ft	
40	LOW LIQUID LEVEL ( $l_3 + l_4$ )	2 _____ ft	
41	C.L. OF DISCHARGE	3 _____ ft	
42	SUMP DEPTH	$l_1$ _____ ft	
43	PUMP LENGTH	$l_2$ _____ ft	
44	GRADE TO DISCH.	$l_3$ _____ ft	
45	GRADE TO LOW LIQUID LVL	$l_4$ _____ ft	
46	GRADE TO 1ST STG IMPL'R.	$l_5$ _____ ft	
47	SUBMERGENCE REQ'D	$l_6$ _____ ft	
48	SUMP DIAMETER	$\Phi d$ _____ ft	
49			
50			
51			
52			
53			
54			
55			
56			
DATASHEET No. _____		Rev: _____	SHEET _____ OF _____

Figure N.1—USC Units Pump Process Data Sheet (Continued)

NOTES		
1	Note #	Rev
2		
3		
4		
5		
6		
7		
8		
9		
10		
11		
12		
13		
14		
15		
16		
17		
18		
19		
20		
21		
22		
23		
24		
25		
26		
27		
28		
29		
30		
31		
32		
33		
34		
35		
36		
37		
38		
39		
40		
41		
42		
43		
44		
45		
46		
47		
48		
49		
50		
51		
52		
53		
54		
55		
56		
57		
58		

DATASHEET No. \_\_\_\_\_ Rev: \_\_\_\_\_ SHEET \_\_\_\_\_ OF \_\_\_\_\_

**Figure N.1—USC Units Pump Process Data Sheet (Continued)**

CLIENT: \_\_\_\_\_

PROJECT TITLE: \_\_\_\_\_

JOB NUMBER: \_\_\_\_\_

EQUIPMENT NUMBER: \_\_\_\_\_

EQUIPMENT SERVICE: \_\_\_\_\_

SERIAL NUMBER: \_\_\_\_\_

REQ / SPEC NUMBER : \_\_\_\_\_

PURCHASE ORDER NUMBER : \_\_\_\_\_

Cells coloured thus  contain drop-down options  
 Text in BLACK color are by Purchaser  
 Text in BLUE color are by Supplier  
 Text in RED color are by Purchaser OR Supplier

COMMENTS: \_\_\_\_\_  
 \_\_\_\_\_  
 \_\_\_\_\_  
 \_\_\_\_\_  
 \_\_\_\_\_  
 \_\_\_\_\_  
 \_\_\_\_\_  
 \_\_\_\_\_

ADDITIONAL / RELATED DATASHEETS					
ITEM / TAG NUMBERS	ATT	ITEM / TAG NUMBERS	ATT	ITEM / TAG NUMBERS	ATT
PUMP(s)					
MOTOR(s)					
GEAR(s)					
TURBINE(s)					

APPLICABLE OVERLAY STANDARDS \_\_\_\_\_

Rev	Date	Description	By	Checked				

	<b>CENTRIFUGAL PUMP DATASHEET</b>	DATASHEET No.
	Sheet	of

Figure N.2—SI Units Pump Process Data Sheet

CENTRIFUGAL PUMP DATASHEET								
GENERAL								
1	Note	APPLICABLE TO: _____	APPLICABLE NATIONAL / INTERNATIONAL STANDARD: _____				Rev	
2	CLIENT	_____	UNIT	_____				
3	SITE	_____	SERVICE	_____				
4	NO. REQ	_____	PUMP SIZE	TYPE	_____			No. STAGES
5	MANUFACTURER	_____	MODEL	_____			SERIAL NO.	
6	EQUIPMENT NUMBER	_____						
LIQUID CHARACTERISTICS								
9		Units	Ⓔ RATED TEMP	Ⓔ MAXIMUM TEMP	Ⓔ MINIMUM TEMP	Alternate LIQUID		
10	LIQUID TYPE OR NAME	_____	_____	_____	_____	_____		
11	PUMPING TEMPERATURE	°C	_____	_____	_____	_____		
12	VAPOR PRESSURE	kPa a	_____	_____	_____	_____		
13	RELATIVE DENSITY (3.1.52)	_____	_____	_____	_____	_____		
14	SPECIFIC HEAT	kJ/(kg·K)	_____	_____	_____	_____		
15	VISCOSITY	Pa s	_____	_____	_____	_____		
OPERATING CONDITIONS (5.1.3)								
18		Units	Rated	Normal	Alt Condition 1	Alt Condition 2	Alt Condition 3	Alt Condition 4
19					(Name 1)	(Name 2)	(Name 3)	(Name 4)
20	NPSHA Datum:	_____						
21	PUMPING TEMPERATURE	°C	_____	_____	_____	_____	_____	_____
22	FLOW	m³/s	_____	_____	_____	_____	_____	_____
23	DISCHARGE PRESSURE (5.3.2)	kPa a	_____	_____	_____	_____	_____	_____
24	SUCTION PRESSURE	kPa a	_____	_____	_____	_____	_____	_____
25	DIFFERENTIAL PRESSURE	kPa	_____	_____	_____	_____	_____	_____
26	DIFFERENTIAL HEAD	m	_____	_____	_____	_____	_____	_____
27	NPSHA	m	_____	_____	_____	_____	_____	_____
28	HYDRAULIC POWER	kW	_____	_____	_____	_____	_____	_____
SERVICE (CONTINUOUS/INTERMITTENT): _____ * IF INTERMITTENT, NO. OF STARTS: _____ PUMPS OPERATE IN: _____ CORROSION DUE TO: (5.12.1.9) _____ EROSION DUE TO: (5.12.1.9) _____ H2S CONCENTRATION (ppm): (5.12.1.13) _____ CHLORIDE CONCENTRATION (ppm): _____ PARTICULATE SIZE (DIA IN MICRONS) _____ PARTICULATE CONCENTRATION (ppm) _____ CORROSION ALLOWANCE (5.3.10): _____ DESIGN NOTES: _____								
INSTALLATION LOCATION: _____ IF INDOOR, TEMPERATURE: MAX: _____ °C MIN: _____ °C ELECTRIC AREA CLASSIFICATION (5.1.28): DIVISION _____ ZONE _____ GROUP _____ TEMP CLASS _____ PUMP VALVE START POSITION: _____								
PERFORMANCE				DRIVER (7.1)				
46	PROPOSAL CURVE NO.	_____	RPM	_____				
47	IMPELLER DIA: RATED _____ MAX. _____ MIN. _____	mm		DRIVER TYPE _____				
48	RATED POWER: _____ kW	EFFICIENCY _____ (%)	VARIABLE SPEED REQUIRED _____					
49	RATED CURVE BEP FLOW (at rated impeller diameter) (5.1.15): _____	m³/s		SOURCE OF VARIABLE SPEED _____				
50	MIN FLOW: THERMAL _____ m³/s STABLE _____ m³/s	m³/s		MANUFACTURER _____				
51	PREFERRED OPERATING REGION (5.1.16) _____ to _____	m³/s		NAMEPLATE POWER: _____ kW				
52	ALLOWABLE OPERATING REGION (5.9.4.1) _____ to _____	m³/s		NOMINAL RPM _____				
53	MAX HEAD @ RATED IMPELLER _____	m		RATED LOAD RPM _____				
54	MAX POWER @ RATED IMPELLER _____	kW		FRAME _____				
55	NPSH3 AT RATED FLOW (5.1.9): _____	m		ORIENTATION _____				
56	CENTERLINE OF PUMP TO NPSHA DATUM _____	m		LUBRICATION _____				
57	NPSH MARGIN AT RATED FLOW (5.1.10): _____	m		BEARING TYPE _____				
58	SPECIFIC SPEED (5.1.17) _____	m³/s, rpm, m		RADIAL _____				
59	SUCTION SPECIFIC SPEED LIMIT (5.1.11) _____	m³/s, rpm, m		THRUST _____				
60	SUCTION SPECIFIC SPEED (5.1.11) _____	m³/s, rpm, m		STARTING METHOD _____				
61	MAX. ALLOWABLE SOUND PRESSURE LEVEL (5.1.19) _____	(dBA)		DRIVER DATASHEET NUMBER _____				
62	ESTIMATED MAX. SOUND PRESSURE LEVEL _____	(dBA)		DRIVE DESIGN STANDARD _____				
63	MAX. ALLOWABLE SOUND POWER LEVEL (5.1.19) _____	(dB)						
64	ESTIMATED MAX SOUND POWER LEVEL _____	(dB)						
65								
DATASHEET No. _____				Rev: _____		SHEET _____ of _____		

Figure N.2—SI Units Pump Process Data Sheet (Continued)

CENTRIFUGAL PUMP DATASHEET		CONSTRUCTION	Rev
1	Note		
2	API PUMP TYPE (Table 1):		CASING MOUNTING (6.3.14, 9.3.8.3):
3			CASING TYPE:
4	NOZZLE CONNECTIONS (6.4.2):		OH3 BACK-PULLOUT LIFTING DEVICE REQ'D. (9.1.2.6)
5		Size Facing Rating Position	CASING PRESSURE RATING:
6	SUCTION		MAWP (6.3.6): kPa @ °C
7	DISCHARGE		HYDROTEST (8.3.2.2): kPa @ °C
8	PRESSURE CASING AUX. CONNECTIONS: (6.4.3)		WETTING AGENT REQUIRED FOR HYDROTEST (8.3.2.7):
9		No. Size Type Facing Rating Posn.	HYDROTEST OH PUMP AS ASSEMBLY (8.3.2.14):
10	BALANCE/LEAK OFF		SUCT'N PRESS. REGIONS DESIGNED FOR MAWP (6.3.8):
11	DRAIN		
12	VENT		ROTOR:
13	PRESSURE GAGE		SHAFT FLEXIBILITY INDEX (SFI) (9.1.1.3)
14	TEMP GAGE		FIRST CRITICAL SPEED WET (MULTISTAGE PUMPS ONLY)
15	WARM-UP LINE		COMPONENT BALANCE TO ISO 1940-1, G1 (6.9.3.4):
16			SHRINK-FIT-LIMITED MOVEMENT IMPELLERS (9.2.2.3)
17	DRAIN VALVE SUPPLIED BY (7.6.2.5)		ROTATION (VIEWED FROM COUPLING END):
18	DRAINS MANIFOLDED (7.6.2.5)		IMPELLERS INDIVIDUALLY SECURED (6.6.3):
19	VENT VALVE SUPPLIED BY		
20	VENTS MANIFOLDED		COUPLING: (7.2)
21	THREADED CONS FOR PIPELINE SERVICE & < 55°C (6.4.3.2)		MANUFACTURER
22	SPECIAL FITTINGS FOR TRANSITIONING (6.4.3.3)		MODEL
23	CYLINDRICAL THREADS REQUIRED (6.4.3.2)		RATING ( kW / 100 RPM )
24	MACHINED AND STUDDED AUX CONNECTIONS (6.4.3.6)		SPACER LENGTH (7.2.2.d) mm
25	ROUTE DRAIN TO SKID EDGE		SERVICE FACTOR (7.2.3)
26			RIGID-TYPE
27			COUPLING WITH HYDRAULIC FIT (7.2.9)
28	MATERIAL (6.12.1.1)		COUPLING WITH PROPRIETARY CLAMPING DEVICE (7.2.10)
29	ANNEX H CLASS		COUPLING IN COMPLIANCE WITH (7.2.4)(7.2.2.f)
30	MINIMUM DESIGN METAL TEMPERATURE (6.12.4.1) °C		GUARDS (7.3)
31	MAXIMUM ALLOWABLE TEMPERATURE (3.1.20) °C		COUPLING AND SHAFT GUARD STANDARD (7.3)
32	REDUCED-HARDNESS MATERIALS REQ'D (6.12.1.14)		IGNITION HAZARD ASSESSMENT PER EN 13463-1 (7.3.2; 7.3.3.4)
33	APPLICABLE HARDNESS STANDARD (6.12.1.14)		COUPLING GUARD MATERIAL (7.3.2.1; 7.3.3.3):
34	BARREL:		SHAFT GUARD MATERIAL (7.3.2.1; 7.3.3.3):
35	CASE:		SPARK RESISTANT MATERIAL REQUIRED (7.3.2.1):
36	DIFFUSERS		
37	IMPELLER:		BASEPLATE
38	IMPELLER WEAR RING:		API BASEPLATE NUMBER (ANNEX D):
39	CASE WEAR RING:		IF NON-STD BASEPLATE DIMENSIONS (LxW) ( mm <sup>2</sup> ):
40	SHAFT:		BASEPLATE CONSTRUCTION (7.4)
41	BOWL (IF VS-TYPE)		BASEPLATE DRAINAGE (7.4.1)
42			MOUNTING:
43			NON-GROUT CONSTRUCTION (7.4.1.e):
44	BEARINGS AND BEARING HOUSINGS (6.10.1)		SUPPLIED WITH: ● GROUT AND VENT HOLES
45	BEARING (TYPE / NUMBER):		● DRAIN CONNECTION
46	RADIAL		DEMONSTRATE BASEPLATE PAD FLATNESS (7.4.9)
47	THRUST		PROVIDE SPACER PLATE UNDER ALL EQUIPMENT FEET (7.4.10)
48	REVIEW AND APPROVE THRUST BEARING SIZE: (9.2.5.2.6)		BOLT OH 3/4/5 PUMP TO PAD / FOUNDATION:
49	LUBRICATION (6.11.3) (9.3.12.4):		PROVIDE SOLEPLATE FOR OH 3/4/5 PUMPS (9.1.2):
50	PRESSURE LUBE SYSTEM TO API-614, CHAPTER:		
51	API 614 DATASHEETS ATTACHED (9.2.6.4)		
52	PRESSURIZED LUBE OIL SYSTEM MOUNTED ON BASEPLATE:		
53	LOCATION OF PRESSURIZED LUBE OIL SYSTEM:		
54	INTERCONNECTING PIPING PROVIDED BY		
55	OIL VISC. ISO GRADE	VG	
56	VENT-TO-HOUSING CONSTANT LEVEL OILER (6.10.2.4):		
57	OIL MIST PROVISIONS (6.11.3)		
58	GREASE LUBRICATION (6.11.4)		
DATASHEET No. _____		Rev: _____	SHEET _____ of _____

Figure N.2—SI Units Pump Process Data Sheet (Continued)



CENTRIFUGAL PUMP DATASHEET																											
1	Note	<b>INSTRUMENTATION</b>	<b>SEAL SUPPORT SYSTEM MOUNTING</b>																								
2		INSTRUMENTATION PER API-670 (7.5.2)	MOUNTED ON PUMP BASEPLATE (7.6.1.4)																								
3		ACCELEROMETERS (7.5.2.1)	LOCATION ON OR OFF BASEPLATE (7.4.6) :																								
4		NUMBER OF ACCELEROMETERS _____	INTERCONNECTING PIPING BY _____																								
5		MOUNTING LOCATION: _____																									
6		PROVISION FOR MTG ONLY (6.10.2.13)																									
7		FLAT SURFACE REQUIRED (6.10.2.14)																									
8			<b>MECHANICAL SEAL (6.8)</b>																								
9		VIBRATION PROBES (7.5.2.2)	API 682 DATASHEET ATTACHED :																								
10		VIBRATION PROBES REQUIRED (7.5.2.2)	ADDITIONAL CENTRAL FLUSH PORT (6.8.9)																								
11		NUMBER PER RADIAL BEARING _____	HEATING JACKET REQ'D. (6.8.11)																								
12		NUMBER PER AXIAL BEARING _____																									
13		THREADED PROVISION FOR MTG ONLY (6.10.2.13; 6.6.12)																									
14		FLAT SURFACE PROVISION ONLY (6.10.2.14)																									
15		MONITORS AND CABLES SUPPLIED BY (7.5.2.4)	<b>HEATING AND COOLING (6.1.23-6.1.27)</b>																								
16			COOLING REQ'D																								
17		TEMPERATURE DETECTORS (7.5.2.3)	COOLING WATER PIPING PLAN (7.6.3.1)																								
18		TEMP. PROBES REQUIRED (7.5.2.3)	COOLING WATER PIPING																								
19		PROVISIONS FOR MOUNTING ONLY (6.10.2.2)	<b>FITTINGS</b>																								
20		RADIAL BEARING TEMP.	COOLING WATER PIPING MATERIALS																								
21		NUMBER PER RADIAL BEARING _____	COOLING WATER REQUIREMENTS: SUPPLY PRESSURE _____ kPa																								
22		THRUST BEARING TEMP.	BEARING HOUSING _____ m <sup>3</sup> /s																								
23		NUMBER PER THRUST BEARING ACTIVE SIDE _____	HEAT EXCHANGER _____ m <sup>3</sup> /s																								
24		NUMBER PER THRUST BEARING INACTIVE SIDE _____	TOTAL COOLING WATER _____ m <sup>3</sup> /s																								
25		TEMP. GAUGES (WITH THERMOWELLS) (9.1.3.5)	HEATING MEDIUM _____																								
26		TEMP. GAUGE LOCATION _____	HEATING PIPING _____																								
27		SUPPLY UPPER/LOWER CASING RTD'S FOR WARMUP																									
28			<b>PIPING &amp; APPURTENANCES</b>																								
29		PRESSURE GAUGE TYPE _____	TAG ALL ORIFICES (7.6.2.4)																								
30		PRESSURE GAUGE LOCATION _____	SOCKET WELD UNION ON 1st SEAL GLAND NIPPLE (7.6.2.8)																								
31			MANIFOLD AUX PIPING SYSTEMS AT SKID EDGE (7.6.1.6)																								
32																											
33		<b>PRESSURE VESSEL DESIGN CODE REFERENCES</b>																									
34		THESE REFERENCES SHALL BE PROVIDED BY THE MANUFACTURER																									
35		CASTING FACTORS USED IN DESIGN (PER TABLE 4)																									
36		SOURCE OF MATERIAL PROPERTIES (6.3.5)																									
37																											
38		<b>WELDING AND REPAIRS (6.12.3.1)</b>																									
39		THESE REFERENCES SHALL BE PROVIDED BY THE PURCHASER. (DEFAULT TO TABLE 11 IF NO PURCHASER PREFERENCE IS STATED)																									
40		ALTERNATIVE WELDING CODES AND STANDARDS																									
41		WELDING REQUIREMENT (APPLICABLE CODE OR STANDARD)																									
42		ALTERNATIVE WELDER/OPERATOR QUALIFICATION STANDARD																									
43		ALTERNATIVE WELDING PROCEDURE QUALIFICATION STANDARD																									
44		NON-PRESSURE RETAINING STRUCTURAL WELDING STANDARD (BASEPLATES OR SUPPORTS)																									
45		STANDARD FOR MAGNETIC PARTICLE OR LIQUID PENETRANT EXAMINATION (PLATE EDGES)																									
46		STANDARD FOR POSTWELD HEAT TREATMENT																									
47		STANDARD FOR POSTWELD HEAT TREATMENT OF CASING FABRICATION WELDS																									
48																											
49		<b>MATERIAL INSPECTION</b>																									
50		THESE REFERENCES SHALL BE PROVIDED BY THE PURCHASER.																									
51		DEFAULT TO TABLE 14	TABLE 14 INSPECTION CLASS:																								
52		ALTERNATIVE MATERIAL INSPECTIONS AND ACCEPTANCE CRITERIA (SEE TABLE 15, 8.2.2.5)																									
53		<table border="1" style="width:100%; border-collapse: collapse;"> <thead> <tr> <th style="width: 30%;">TYPE OF INSPECTION</th> <th style="width: 20%;">METHOD</th> <th style="width: 20%;">FOR FABRICATIONS</th> <th style="width: 30%;">FOR CASTINGS</th> </tr> </thead> <tbody> <tr> <td>RADIOGRAPHY</td> <td></td> <td></td> <td></td> </tr> <tr> <td>ULTRASONIC INSPECTION</td> <td></td> <td></td> <td></td> </tr> <tr> <td>MAGNETIC PARTICLE INSPECTION</td> <td></td> <td></td> <td></td> </tr> <tr> <td>LIQUID PENETRANT INSPECTION</td> <td></td> <td></td> <td></td> </tr> <tr> <td>VISUAL INSPECTION (all surfaces)</td> <td></td> <td></td> <td></td> </tr> </tbody> </table>		TYPE OF INSPECTION	METHOD	FOR FABRICATIONS	FOR CASTINGS	RADIOGRAPHY				ULTRASONIC INSPECTION				MAGNETIC PARTICLE INSPECTION				LIQUID PENETRANT INSPECTION				VISUAL INSPECTION (all surfaces)			
TYPE OF INSPECTION	METHOD	FOR FABRICATIONS	FOR CASTINGS																								
RADIOGRAPHY																											
ULTRASONIC INSPECTION																											
MAGNETIC PARTICLE INSPECTION																											
LIQUID PENETRANT INSPECTION																											
VISUAL INSPECTION (all surfaces)																											
54																											
55																											
56																											
57																											
58																											
59																											
60																											
		DATASHEET No. _____	Rev: _____ SHEET _____ OF _____																								

Figure N.2—SI Units Pump Process Data Sheet (Continued)

CENTRIFUGAL PUMP DATASHEET							Rev
1	Note	SURFACE PREPARATION, PAINT & SPARES				TEST	
2	MANUFACTURER'S STANDARD (8.4.3.4)					SHOP INSPECTION (8.1.1.1)	
3	OTHER (SEE BELOW)					PERF. CURVE & DATA APPROVAL REQ'D PRIOR TO SHIPMENT (8.3.3.4.6):	
4	SPECIFICATION NO.					TEST WITH SUBSTITUTE SEAL (8.3.3.3.1)	
5	PUMP:					MATERIAL CERTIFICATION REQUIRED (6.12.1.8):	
6	PUMP SURFACE PREPARATION					CASING	
7	PRIMER					IMPELLER	
8	FINISH COAT					SHAFT	
9	BASEPLATE:					OTHER	
10	SURFACE PREPARATION					CASTING REPAIR WELD PROCEDURE APPROVAL REQ'D (6.12.2.5):	
11	PRIMER:					INSPECTION REQUIRED FOR CONNECTION WELDS (6.12.3.4)	
12	FINISH COAT					MAG PARTICLE	
13	UNDERSIDE					RADIOGRAPHY	
14						LIQUID PENETRANT	
15	SHIPMENT: (8.4)					ULTRASONIC	
16	EXPORT BOXING REQUIRED					HARDNESS TEST REQUIRED (6.12.1.14; 8.2.2.7)	
17	PREPARE FOR OUTDOOR STORAGE (NUMBER OF MONTHS):					ADDITIONAL SUBSURFACE EXAMINATION (6.12.1.6) (8.2.1.3)	
18						FOR:	
19	SPARE ROTOR ASSEMBLY PACKAGED FOR:					METHOD:	
20	ROTOR STORAGE ORIENTATION (9.2.8.2)					PMI TESTING REQUIRED (8.2.2.8)	
21	SHIPPING & STORAGE CONTAINER SUITABLE FOR					COMPONENTS TO BE TESTED:	
22	VERTICAL STORAGE (9.2.8.3):					RESIDUAL UNBALANCE TEST (J.4.1.2)	
23	N2 PURGE REQUIRED (9.2.8.4):					NOTIFICATION OF SUCCESSFUL PERFORMANCE TEST (8.1.1.3) (8.3.3.4.6)	
24						BASEPLATE (NOZZLE LOAD) TEST (7.4.24)	
25	SPARE PARTS (10.3.4.2)					HYDROSTATIC TEST (8.3.2)	
26	START-UP					HYDROSTATIC TEST OF BOWLS & COLUMN (9.3.13.1)	
27	NORMAL MAINTENANCE					PERFORMANCE TEST (8.3.3)	
28						RETEST ON SEAL LEAKAGE (8.3.3.3.2)	
29						TEST DATA POINTS TO (8.3.3.4)	
30						ALTERNATE TEST TOLERANCES PER (8.3.3.5)	
31						NPSH (8.3.4.3)	
32						NPSH BASED ON 1ST STG ONLY ALLOWED (8.3.4.3.2)	
33						TEST NPSHA LIMITED TO 110% SITE NPSHA (8.3.3.7)	
34						RETEST REQUIRED AFTER FINAL HEAD ADJUSTMENT (8.3.3.8.2)	
35						COMPLETE UNIT TEST (8.3.4.4.1)	
36						SOUND LEVEL TEST (8.3.4.5)	
37						CLEANLINESS PRIOR TO FINAL ASSEMBLY (8.2.2.6)	
38	COORDINATION MEETING REQUIRED (10.1.3)					LOCATION OF CLEANLINESS INSPECTION:	
39	MAXIMUM DISCHARGE PRESSURE TO INCLUDE (6.3.2)					CHECK FOR CO-PLANAR MOUNTING PAD FLATNESS (7.4.8)	
40	MAX RELATIVE DENSITY					MECHANICAL RUN TEST UNTIL OIL TEMP STABLE (8.3.4.2.1)	
41	OPERATION TO TRIP SPEED					4 HR. MECH RUN AFTER OIL TEMP STABLE (8.3.4.2.2)	
42	MAX DIA. IMPELLERS AND/OR NO OF STAGES					BRG HSG RESONANCE TEST (8.3.4.7)	
43	CONNECTION DESIGN APPROVAL (9.2.1.4)					STRUCTURAL RESONANCE TEST (9.3.9.2)	
44	TORSIONAL ANALYSIS / REPORT (6.9.2)					REMOVE / INSPECT HYDRODYNAMIC BEARINGS AFTER TEST (9.2.7.4)	
45	PROGRESS REPORTS (10.3.3)					AUXILIARY EQUIPMENT TEST (8.3.4.6)	
46	OUTLINE OF PROCEDURES USED FOR OPTIONAL TESTS (10.2.5)					EQUIPMENT TO BE INCLUDED IN AUXILIARY TESTS:	
47	ADDITIONAL DATA REQUIRING 20 YEARS RETENTION (8.2.1.1)					LOCATION OF AUXILIARY EQUIPMENT TEST:	
48	LATERAL ANALYSIS REQUIRED (9.2.4.1.2)						
49	ROTOR DYNAMIC BALANCE TO 4WIN (6.9.3.5)						
50	INSTALLATION LIST IN PROPOSAL (10.2.3.J)					IMPACT TEST (6.12.4.3) PER EN 13445	
51	VFD STEADY STATE FORCED RESPONSE ANALYSIS (6.9.2.3)					PER ASME SECTION VIII	
52	TRANSIENT FORCED RESPONSE (6.9.2.4)					CASING DISASSEMBLY AFTER TEST (8.3.3.9)	
53	BEARING LIFE CALCULATIONS REQUIRED (6.10.1.11)					SPARE PARTS TEST (8.3.4.8)	
54	CASING RETIREMENT THICKNESS DRAWING (10.3.2.3)						
55	CONNECTION BOLTING (7.6.1.7)						
56	VENDOR TO KEEP REPAIR AND HT RCDS (8.2.1.1.c)						
57	VENDOR SUBMIT TEST PROCEDURES (8.3.1.1)						
58	SUBMIT INSPECTION CHECK LIST (8.1.5)						
59	ACOUSTIC ANALYSIS OF CROSSOVER PASSAGE (BB3, BB5)(9.2.1.5)						
60	API-691 DOCUMENTATION REQUIRED (6.1.3.1)						
DATASHEET No. _____							Rev: _____
							SHEET _____ OF _____

Figure N.2—SI Units Pump Process Data Sheet (Continued)

VERTICAL PUMP SUPPLEMENTAL DATASHEET				
1	Note	VERTICAL PUMP TYPE (Table 1) <span style="background-color: #d9ead3; padding: 2px;"> </span>		Rev
2	REMARKS			
3				
4				
5	VERTICAL PUMPS		VERTICAL PUMPS (CONTD)	
6	PUMP THRUST:	(+ ) UP	(- ) DOWN	LINE SHAFT:
7	STATIC THRUST	N	N	LINE SHAFT DIAMETER <span style="background-color: #d9ead3; padding: 2px;"> </span> mm
8	AT MIN FLOW	N	N	TUBE DIAMETER <span style="background-color: #d9ead3; padding: 2px;"> </span> mm
9	AT RATED FLOW	N	N	LINESHAFT CONNECTION <span style="background-color: #d9ead3; padding: 2px;"> </span>
10	AT MAX FLOW	N	N	LEVEL CONTROL <span style="background-color: #d9ead3; padding: 2px;"> </span>
11	MAX THRUST	N	N	SUCTION STRAINER TYPE <span style="background-color: #d9ead3; padding: 2px;"> </span>
12	SEPARATE SOLEPLATE REQUIRED (9.3.8.3.2)	N	N	IMPELLER COLLETS ACCEPTABLE (6.6.3) <span style="background-color: #d9ead3; padding: 2px;"> </span>
13	SOLEPLATE Length x Width	mm X	mm	HARDENED SLEEVES UNDER BEARINGS (9.3.10.4) <span style="background-color: #d9ead3; padding: 2px;"> </span>
14	SOLEPLATE THICKNESS	mm	mm	STRUCTURAL ANALYSIS (9.3.5) <span style="background-color: #d9ead3; padding: 2px;"> </span>
15	SEPARATE MOUNTING FLANGE REQUIRED (9.3.8.3.1)	N	N	SUCTION CAN
16				THICKNESS <span style="background-color: #d9ead3; padding: 2px;"> </span> mm
17	COLUMN PIPE:	mm	mm	LENGTH <span style="background-color: #d9ead3; padding: 2px;"> </span> m
18	DIAMETER	mm	m	DIAMETER <span style="background-color: #d9ead3; padding: 2px;"> </span> mm
19	TOTAL COLUMN LENGTH	m	m	CAN DRAIN PIPED TO SURFACE (9.3.13.4) <span style="background-color: #d9ead3; padding: 2px;"> </span>
20	NUMBER OF SECTIONS	m	m	ELLIPTICAL BOTTOM HEAD REQUIRED (9.3.2.5) <span style="background-color: #d9ead3; padding: 2px;"> </span>
21	SPACING (LENGTH PER SECTION)	m	m	PRESSURE CASING WALLS USING SEAMLESS PIPE (9.3.2.7) <span style="background-color: #d9ead3; padding: 2px;"> </span>
22				HYDROTEST BOWLS/COLUMN @ MAX DIFF PRESSURE (9.3.13.1) <span style="background-color: #d9ead3; padding: 2px;"> </span>
23	GUIDE BUSHINGS:			
24	NUMBER	mm	mm	
25	LINE SHAFT BEARING SPACING	mm	mm	
26	GUIDE BUSHING LUBE:	mm	mm	
27				
28	MATERIALS (additional)			
29	SUCTION CAN / BARREL:	mm	mm	LINESHAFT SLEEVES: <span style="background-color: #d9ead3; padding: 2px;"> </span>
30	DISCHARGE HEAD:	mm	mm	BEARING RETAINER: <span style="background-color: #d9ead3; padding: 2px;"> </span>
31	BOWL SHAFT:	mm	mm	SHAFT ENCLOSING TUBE: <span style="background-color: #d9ead3; padding: 2px;"> </span>
32	LINESHAFT:	mm	mm	DISCHARGE COLUMN: <span style="background-color: #d9ead3; padding: 2px;"> </span>
33	LINESHAFT HARDFACING:	mm	mm	PRESSURE RATING: <span style="background-color: #d9ead3; padding: 2px;"> </span>
34	BELLMOUTH:	mm	mm	MAWP ( kPa ) <span style="background-color: #d9ead3; padding: 2px;"> </span>
35	BOWL BEARING:	mm	mm	HEAD <span style="background-color: #d9ead3; padding: 2px;"> </span>
36	LINESHAFT BEARING:	mm	mm	COLUMN PIPE <span style="background-color: #d9ead3; padding: 2px;"> </span>
37				BOWL <span style="background-color: #d9ead3; padding: 2px;"> </span>
38	SUMP ARRANGEMENT			
39	SUMP DIMENSIONS:			
40	GRADE ELEVATION	1	m	
41	LOW LIQUID LEVEL ( $l_3 + l_4$ )	2	m	
42	C.L. OF DISCHARGE	3	m	
43	SUMP DEPTH	$l_1$	m	
44	PUMP LENGTH	$l_2$	m	
45	GRADE TO DISCH.	$l_3$	m	
46	GRADE TO LOW LIQUID LVL	$l_4$	m	
47	GRADE TO 1ST STG IMPL'R.	$l_5$	m	
48	SUBMERGENCE REQ'D	$l_6$	m	
49	SUMP DIAMETER	$\phi d$	m	
50				
51				
52				
53				
54				
55				
56				
DATASHEET No. <span style="background-color: #d9ead3; padding: 2px;"> </span>		Rev: <span style="background-color: #d9ead3; padding: 2px;"> </span>		SHEET <span style="background-color: #d9ead3; padding: 2px;"> </span> OF <span style="background-color: #d9ead3; padding: 2px;"> </span>

Figure N.2—SI Units Pump Process Data Sheet (Continued)

NOTES		
1	Note #	Rev
2		
3		
4		
5		
6		
7		
8		
9		
10		
11		
12		
13		
14		
15		
16		
17		
18		
19		
20		
21		
22		
23		
24		
25		
26		
27		
28		
29		
30		
31		
32		
33		
34		
35		
36		
37		
38		
39		
40		
41		
42		
43		
44		
45		
46		
47		
48		
49		
50		
51		
52		
53		
54		
55		
56		
57		
58		

DATASHEET No. \_\_\_\_\_ Rev: \_\_\_\_\_ SHEET \_\_\_\_\_ OF \_\_\_\_\_

**Figure N.2—SI Units Pump Process Data Sheet (Continued)**

API Section Heading	API 610 Datasheet Field Name	Datasheet Value	Unit	API Paragraph Reference	HI 50.7 EDE Global Number
GENERAL	JOB NUMBER-				280
GENERAL	Equipment Number-				279
GENERAL	REQ NO.				488
GENERAL	PURCH ORDER NO.-				469
GENERAL	APPLICABLE TO:-				625
GENERAL	Client-				409
GENERAL	UNIT-				443
GENERAL	SITE-				539
GENERAL	SERVICE-				523
GENERAL	NO. REQ-				391
GENERAL	PUMP SIZE-				461
GENERAL	TYPE				688
GENERAL	NO. STAGES-				555
GENERAL	MANUFACTURER-				457
GENERAL	MODEL-				458
GENERAL	Serial Number-				522
GENERAL	Comments Page 1				241
GENERAL	Project Title-				446
DATA SHEETS	PUMP-ITEM NO.				449
DATA SHEETS	MOTOR-ITEM NO.				157
DATA SHEETS	MOTOR DATASHEET ATTACHED				
DATA SHEETS	GEAR-ITEM NO.				232
DATA SHEETS	GEAR DATASHEET ATTACHED				
DATA SHEETS	TURBINE-ITEM NO.				629
DATA SHEETS	TURBINE DATASHEET ATTACHED				
DATA SHEETS	APPLICABLE OVERLAY STANDARD(S)				15
REVISIONS	RevisionNumber1				502
REVISIONS	RevisionDate1				623
REVISIONS	RevisionBy1				50
REVISIONS	RevisionDescription1				483
REVISIONS	RevisionChecked1				71
REVISIONS	RevisionChecked2				
REVISIONS	RevisionChecked3				
REVISIONS	RevisionApproved1				
REVISIONS	RevisionApproved2				
HEADER	APPLICABLE NTL/INTL STANDARD				14
HEADER	DATASHEET NO.				
LIQUID CHARACTERISTICS	Liquid Name				293
LIQUID CHARACTERISTICS	PUMPING TEMPERATURE-RATED			3.1.25	452
LIQUID CHARACTERISTICS	VAPOR PRESS. -AT RATED TEMP				
LIQUID CHARACTERISTICS	RELATIVE DENSITY-AT RATED TEMP			3.1.52	
LIQUID CHARACTERISTICS	SPECIFIC HEAT-AT RATED TEMP				
LIQUID CHARACTERISTICS	VISCOSITY-AT RATED TEMP				
LIQUID CHARACTERISTICS	PUMPING TEMP-MAX.			3.1.25	320
LIQUID CHARACTERISTICS	VAPOR PRESS. -MAX.				324
LIQUID CHARACTERISTICS	RELATIVE DENSITY-MAX.			3.1.52	314
LIQUID CHARACTERISTICS	SPECIFIC HEAT-MAX.				550
LIQUID CHARACTERISTICS	VISCOSITY (cP) -MIN				1921
LIQUID CHARACTERISTICS	PUMPING TEMP-MIN				345
LIQUID CHARACTERISTICS	VAPOR PRESS. -MIN				349
LIQUID CHARACTERISTICS	RELATIVE DENSITY-MIN			3.1.52	341
LIQUID CHARACTERISTICS	SPECIFIC HEAT-MIN				346
LIQUID CHARACTERISTICS	Viscosity-MAX.				1923
LIQUID CHARACTERISTICS	Liquid Name-ALTERNATE				
LIQUID CHARACTERISTICS	VAPOR PRESS. -ALTERNATE				
LIQUID CHARACTERISTICS	RELATIVE DENSITY-ALTERNATE			3.1.52	
LIQUID CHARACTERISTICS	SPECIFIC HEAT-ALTERNATE				
LIQUID CHARACTERISTICS	VISCOSITY-ALTERNATE				
LIQUID CHARACTERISTICS	CHLORIDE CONCENTRATION-			6.12.1.9	72
OPERATING CONDITIONS	Flow-NORMAL				373
OPERATING CONDITIONS	Flow-RATED				478
OPERATING CONDITIONS	SuctionPressure-MAX				323
OPERATING CONDITIONS	SuctionPressure-RATED				482
OPERATING CONDITIONS	DischargePressure-RATED			6.3.2	147
OPERATING CONDITIONS	Differential Pressure-RATED				140
OPERATING CONDITIONS	Differential Head-RATED				139
OPERATING CONDITIONS	NPSHA-				381
OPERATING CONDITIONS	NPSHa Datum				681
OPERATING CONDITIONS	AltCondition1 Name				
OPERATING CONDITIONS	AltCondition2 Name				
OPERATING CONDITIONS	AltCondition3 Name				
OPERATING CONDITIONS	AltCondition4 Name				
OPERATING CONDITIONS	NPSHA-NORMAL				
OPERATING CONDITIONS	NPSHA-ALTCONDITION1				
OPERATING CONDITIONS	NPSHA-ALTCONDITION2				
OPERATING CONDITIONS	NPSHA-ALTCONDITION3				
OPERATING CONDITIONS	NPSHA-ALTCONDITION4				
OPERATING CONDITIONS	HYDRAULIC POWER				680
OPERATING CONDITIONS	HYDRAULIC POWER-NORMAL				
OPERATING CONDITIONS	HYDRAULIC POWER-ALTCONDITION1				
OPERATING CONDITIONS	HYDRAULIC POWER-ALTCONDITION2				
OPERATING CONDITIONS	HYDRAULIC POWER-ALTCONDITION3				
OPERATING CONDITIONS	HYDRAULIC POWER-ALTCONDITION4				
OPERATING CONDITIONS	SERVICE-				397

Figure N.3—Data List

OPERATING CONDITIONS	IF INTERMITTENT (STARTS/DAY)-				557
OPERATING CONDITIONS	PUMPS OPERATE IN-				418
OPERATING CONDITIONS	PUMPING TEMP-NORMAL				375
OPERATING CONDITIONS	H2S CONCENTRATION-			§ 12.1.12	249
OPERATING CONDITIONS	CORROSION DUE TO			§ 12.1.9	102
OPERATING CONDITIONS	CORROSION DUE TO			§ 12.1.9	102
OPERATING CONDITIONS	EROSION DUE TO			§ 12.1.9	
OPERATING CONDITIONS	FLOW-ALTCONDITION1				
OPERATING CONDITIONS	FLOW-ALTCONDITION2				
OPERATING CONDITIONS	FLOW-ALTCONDITION3				
OPERATING CONDITIONS	FLOW-ALTCONDITION4				
OPERATING CONDITIONS	SUCTION PRESS -NORMAL				577
OPERATING CONDITIONS	SUCTION PRESS -ALTCONDITION1				
OPERATING CONDITIONS	SUCTION PRESS -ALTCONDITION2				
OPERATING CONDITIONS	SUCTION PRESS -ALTCONDITION3				
OPERATING CONDITIONS	SUCTION PRESS -ALTCONDITION4				
OPERATING CONDITIONS	DISCHARGE PRESSURE -NORMAL				150
OPERATING CONDITIONS	DISCHARGE PRESS -ALTCONDITION1			§ 3.2	
OPERATING CONDITIONS	DISCHARGE PRESS -ALTCONDITION2			§ 3.2	
OPERATING CONDITIONS	DISCHARGE PRESS -ALTCONDITION3			§ 3.2	
OPERATING CONDITIONS	DISCHARGE PRESS -ALTCONDITION4			§ 3.2	
OPERATING CONDITIONS	DIFFERENTIAL PRESSURE-NORMAL				138
OPERATING CONDITIONS	DIFFERENTIAL PRESS -ALTCONDITION1				
OPERATING CONDITIONS	DIFFERENTIAL PRESS -ALTCONDITION2				
OPERATING CONDITIONS	DIFFERENTIAL PRESS -ALTCONDITION3				
OPERATING CONDITIONS	DIFFERENTIAL PRESS -ALTCONDITION4				
OPERATING CONDITIONS	DIFF. HEAD-NORMAL				135
OPERATING CONDITIONS	DIFF. HEAD-ALTCONDITION1				
OPERATING CONDITIONS	DIFF. HEAD-ALTCONDITION2				
OPERATING CONDITIONS	DIFF. HEAD-ALTCONDITION3				
OPERATING CONDITIONS	DIFF. HEAD-ALTCONDITION4				
OPERATING CONDITIONS	PARTICULATE SIZE				795
OPERATING CONDITIONS	PARTICULATE CONCENTRATION				795
OPERATING CONDITIONS	CORROSION ALLOWANCE			§ 3.10	
SITE UTILITY DATA	Site Indoor/Outdoor				854
SITE UTILITY DATA	RANGE OF INDOOR TEMPS-MAX				
SITE UTILITY DATA	RANGE OF INDOOR TEMPS-MIN				
SITE UTILITY DATA	Site Heated/Unheated				855
SITE UTILITY DATA	MOUNTED AT				1936
SITE UTILITY DATA	Electrical Area Classification				199
SITE UTILITY DATA	TEMPERATURE CLASSIFICATION				1749
SITE UTILITY DATA	Electrical Area Classification				200
SITE UTILITY DATA	EXPLOSIVE ENVIRONMENT CLASSIFICATION			§ 1.22	1748
SITE UTILITY DATA	TROPICALIZATION REQ'D.-				826
SITE UTILITY DATA	ELEVATION-				7
SITE UTILITY DATA	BAROMETER-				25
SITE UTILITY DATA	RANGE OF AMBIENT TEMPS-MIN				343
SITE UTILITY DATA	RANGE OF AMBIENT TEMPS -MAX				313
SITE UTILITY DATA	RELATIVE HUMIDITY-MIN				343
SITE UTILITY DATA	RELATIVE HUMIDITY-MAX				318
SITE UTILITY DATA	UNUSUAL CONDITIONS				1825
SITE UTILITY DATA	DRIVERS-VOLTAGE				193
SITE UTILITY DATA	DRIVERS-PHASE				192
SITE UTILITY DATA	DRIVERS-HERTZ				191
SITE UTILITY DATA	Electric HEATING-VOLTAGE				198
SITE UTILITY DATA	Electric HEATING-PHASE				195
SITE UTILITY DATA	Electric HEATING-HERTZ				194
SITE UTILITY DATA	Steam DRIVERS-MAX. PRESS				563
SITE UTILITY DATA	Steam DRIVERS-MAX. TEMP				561
SITE UTILITY DATA	Steam DRIVERS-MIN. PRESS				562
SITE UTILITY DATA	Steam DRIVERS-MIN. TEMP				563
SITE UTILITY DATA	Steam HEATING-MAX. PRESS				564
SITE UTILITY DATA	Steam HEATING-MAX. TEMP				565
SITE UTILITY DATA	Steam HEATING-MIN. PRESS				566
SITE UTILITY DATA	Steam HEATING-MIN. TEMP				567
SITE UTILITY DATA	CoolWaterSOURCE-				98
SITE UTILITY DATA	CoolWaterTEMP-INLET			deg C	98
SITE UTILITY DATA	Cooling Water - Mix Return Temp			deg C	97
SITE UTILITY DATA	Cooling Water - Min Design Pressure			barg	93
SITE UTILITY DATA	Cooling Water - Min Return Pressure			barg	95
SITE UTILITY DATA	COOLING WATER CHLORIDE CONCENTRATION-			ppm	92
SITE UTILITY DATA	Site UnderRoof_PartialSides				1741
SITE UTILITY DATA	CONTROL-VOLTAGE				729
SITE UTILITY DATA	CONTROL-PHASE				728
SITE UTILITY DATA	CONTROL-HERTZ				727
SITE UTILITY DATA	SHUTDOWN-VOLTAGE				820
SITE UTILITY DATA	SHUTDOWN-PHASE				819
SITE UTILITY DATA	SHUTDOWN-HERTZ				818
SITE UTILITY DATA	Cooling Water - Mix Design Temp				849
SITE UTILITY DATA	PRESS-INLET				798
SITE UTILITY DATA	INSTRUMENT AIR PRESSURE-MAX				748
SITE UTILITY DATA	INSTRUMENT AIR PRESSURE-MIN				750
PERFORMANCE	PROPOSAL CURVE NO.-				125
PERFORMANCE	RPM-				481
PERFORMANCE	IMPELLER DIA. -RATED				479
PERFORMANCE	IMPELLER DIA -MAX				317
PERFORMANCE	IMPELLER DIA-MIN				344

Figure N.3—Data List (Continued)



PERFORMANCE	RATED POWER-			480
PERFORMANCE	EFFICIENCY-			477
PERFORMANCE	RATED CURVE BEP FLOW (at rated impeller dia)-		8.1.17	478
PERFORMANCE	MINIMUM CONTINUOUS FLOW-THERMAL			327
PERFORMANCE	MINIMUM CONTINUOUS FLOW-STABLE			328
PERFORMANCE	PREFERRED OPER. REGION-FROM		8.1.17	453
PERFORMANCE	PREFERRED OPER. REGION-TO		8.1.17	430
PERFORMANCE	ALLOWABLE OPER. REGION-FROM		8.9.4.1	339
PERFORMANCE	Max Allow Flow-TO		8.9.4.1	312
PERFORMANCE	MAX HEAD @ RATED IMPELLER-		8.1.14	315
PERFORMANCE	MAX POWER @ RATED IMPELLER-			319
PERFORMANCE	NPSH3 AT RATED Flow-		8.1.10	1951
PERFORMANCE	SUCTION SPECIFIC SPEED LIMIT		8.1.12	880
PERFORMANCE	SUCTION SPECIFIC SPEED-		8.1.12	581
PERFORMANCE	MAX. SOUND PRESS. LEVEL ALLOWED-		8.1.20	321
PERFORMANCE	EST MAX SOUND PRESS. LEVEL-			214
PERFORMANCE	EST MAX SOUND POWER LEVEL-			213
PERFORMANCE	CL pump to NPSHA Datum		8.1.10	719
PERFORMANCE	NPSH Margin at Rated Flow		8.1.11	788
PERFORMANCE	SPECIFIC SPEED		8.1.18	482
PERFORMANCE	MAX. SOUND POWER LEVEL ALLOWED		8.1.20	759
DRIVER	Driver Type-			175
DRIVER	GEAR-			231
DRIVER	MANUFACTURER-			183
DRIVER	NAMEPLATE POWER-			188
DRIVER	Nominal RPM-			1918
DRIVER	FRAME OR MODEL-			358
DRIVER	ORIENTATION-			360
DRIVER	LUBE-			208
DRIVER	RADIAL BEARING TYPE			351
DRIVER	THRUST BEARING TYPE			353
DRIVER	Starting Method-			1750
DRIVER	Motor Radial Bearing Number			350
DRIVER	Motor Thrust Bearing Number			352
DRIVER	VARIABLE SPEED REQUIRED			858
DRIVER	SOURCE OF VARIABLE SPEED			825
DRIVER	RATED LOAD RPM			809
DRIVER	SEE ATTACHED DRIVER DATA SHEET			
CONSTRUCTION	ROTATION -			503
CONSTRUCTION	PUMP TYPE -		4.2.1	467
CONSTRUCTION	CASING MOUNTING-		8.3.14, 9.3.8.3	58
CONSTRUCTION	CASING TYPE			59
CONSTRUCTION	PUMP SUCTION REGION DESIGNED FOR MAWP-		8.3.8	579
CONSTRUCTION	MAWP-		8.3.8	58
CONSTRUCTION	at temperature-			57
CONSTRUCTION	HYDROTEST PRESSURE-		8.3.2.2	54
CONSTRUCTION	HYDRO AT TEMPERATURE			
CONSTRUCTION	WETTING AGENT REQUIRED FOR HYDRO		8.3.2.7	
CONSTRUCTION	HYDROTEST OH PUMP AS ASSEMBLY-		8.3.2.14	55
CONSTRUCTION	SUCTION-SIZE			585
CONSTRUCTION	SUCTION-FLANGE RATING		8.4.2	578
CONSTRUCTION	SUCTION-FAC'G			573
CONSTRUCTION	SUCTION-POSITION			575
CONSTRUCTION	DISCHARGE-SIZE			152
CONSTRUCTION	DISCHARGE-FLANGE RATING			151
CONSTRUCTION	DISCHARGE-FAC'G			143
CONSTRUCTION	DISCHARGE-POSITION			148
CONSTRUCTION	DRAIN-NO.			439
CONSTRUCTION	DRAIN-SIZE			153
CONSTRUCTION	DRAIN-TYPE			154
CONSTRUCTION	VENT-NO.			841
CONSTRUCTION	VENT-SIZE			842
CONSTRUCTION	VENT-TYPE			843
CONSTRUCTION	PRESSURE GAUGE-NO.			438
CONSTRUCTION	PRESSURE GAUGE-SIZE			437
CONSTRUCTION	PRESSURE GAUGE-TYPE			440
CONSTRUCTION	TEMPERATURE GAUGE-NO.			800
CONSTRUCTION	TEMPERATURE GAUGE-SIZE			801
CONSTRUCTION	TEMPERATURE GAUGE-TYPE			802
CONSTRUCTION	WARM UP LINE-NO.			848
CONSTRUCTION	WARM UP-SIZE			849
CONSTRUCTION	WARM UP-TYPE			850
CONSTRUCTION	BALANCE / LEAK OFF-NO.			22
CONSTRUCTION	BALANCE-SIZE			23
CONSTRUCTION	BALANCE-TYPE			24
CONSTRUCTION	MACHINED AND STUDDED AUX CONNECTIONS-		8.4.3.8	267
CONSTRUCTION	CYLINDRICAL THREADS REQUIRED-		8.4.3.5	131
CONSTRUCTION	COMPONENT BALANCE TO ISO 1940 G1.0-		8.9.3.4	77
CONSTRUCTION	SHRINK FIT -LIMITED MOVEMENT IMPELLERS-		9.2.2.3	531
CONSTRUCTION	COUPLING MANUFACTURER-		7.2	117
CONSTRUCTION	COUPLING MODEL-			118
CONSTRUCTION	COUPLING RATING (POWER/100 RPM)-			120
CONSTRUCTION	SPACER LENGTH-		7.2.2.6	123
CONSTRUCTION	COUPLING SERVICE FACTOR-		7.2.3	108
CONSTRUCTION	RIGID COUPLING			121
CONSTRUCTION	COUPLING WITH HYDRAULIC FIT-		7.2.9	114
CONSTRUCTION	COUPLING WITH PROPRIETARY CLAMPING DEVICE-		7.2.10	111

Figure N.3—Data List (Continued)

CONSTRUCTION	COUPLING GUARD STANDARD PER-			7.3	113
CONSTRUCTION	OHS BACKPULLOUT LIFTING DEVICE REQ'D -			9.1.2.8	392
CONSTRUCTION	IMPELLERS INDIVIDUALLY SECURED			8.8.3	745
CONSTRUCTION	BOLT OH 3/4S PUMP TO PAD / FOUNDATION				712
CONSTRUCTION	VENT-FAC'G				822
CONSTRUCTION	VENT-RATING				824
CONSTRUCTION	VENT-POSITION				823
CONSTRUCTION	Drain Valve Supplied By			7.8.2.5	734
CONSTRUCTION	DRAIN TO SKID EDGE				733
CONSTRUCTION	DRAINS MANFOLDED			7.8.2.5	735
CONSTRUCTION	DRAINS-FAC'G				736
CONSTRUCTION	DRAINS-RATING			8.4.3.1	738
CONSTRUCTION	DRAINS-POSITION				737
CONSTRUCTION	VENT Valve Supplied By				859
CONSTRUCTION	VENTS MANFOLDED				860
CONSTRUCTION	PRESSURE GAUGE-FAC'G				799
CONSTRUCTION	PRESSURE GAUGE-RATING				801
CONSTRUCTION	PRESSURE GAUGE-POSITION				800
CONSTRUCTION	TEMP GAGE-FAC'G				848
CONSTRUCTION	TEMP GAGE-RATING				848
CONSTRUCTION	TEMP GAGE-POSITION				847
CONSTRUCTION	WARM-UP LINE-FAC'G				878
CONSTRUCTION	WARM-UP LINE-RATING				880
CONSTRUCTION	WARM-UP LINE-POSITION				879
CONSTRUCTION	BALANCE/LEAK-FAC'G				705
CONSTRUCTION	BALANCE/LEAK-RATING				707
CONSTRUCTION	BALANCE/LEAK-POSITION				708
CONSTRUCTION	THREADED CONNECTIONS FOR PIPELINE SERVICE			8.4.3.2	854
CONSTRUCTION	SPECIAL FITTINGS FOR TRANSITIONING			8.4.3.3	826
CONSTRUCTION	SHAFT FLEXIBILITY INDEX SFI			9.1.1.3	818
CONSTRUCTION	Flint Cr/Bowl Speed Wht				740
CONSTRUCTION	COUPLING IN COMPLIANCE WITH			7.2.4, 7.2.2.1	857
CONSTRUCTION	COUPLING GUARD MATERIAL			7.3.2.1	
CONSTRUCTION	COUPLING GUARD SPARK RESISTANT MATL			7.3.2.1	
MATERIALS	ANNEX H CLASS-			8.12.1.1	311
MATERIALS	MIN DESIGN METAL TEMP-			8.12.4.1	342
MATERIALS	REDUCED-HARDNESS MATERIALS REQ'D-			8.12.1.13	485
MATERIALS	CASE-				84
MATERIALS	IMPELLER-				288
MATERIALS	IMPELLER WEAR RING-				289
MATERIALS	CASE WEAR RING-				85
MATERIALS	DIFFUSERS-				141
MATERIALS	SHAFT -				525
MATERIALS	Applicable Hardness Standard			8.12.1.13	703
MATERIALS	Bowl (if VS-type)				713
MATERIALS	Inspection Class			Table 14	747
MATERIALS	BARREL				888
BEARINGS AND LUBRICATION	BEARING RADIAL-TYPE			8.10.1	44
BEARINGS AND LUBRICATION	BEARING RADIAL-NUMBER				43
BEARINGS AND LUBRICATION	BEARING THRUST-TYPE				47
BEARINGS AND LUBRICATION	BEARING THRUST-NUMBER				46
BEARINGS AND LUBRICATION	LUBRICATION-			8.11.3, 9.3.12.4	42
BEARINGS AND LUBRICATION	CONSTANT LEVEL OILER PREFERENCE-			8.10.2.4	85
BEARINGS AND LUBRICATION	OIL VISC. ISO GRADE VG-				395
BEARINGS AND LUBRICATION	REVIEW AND APPROVE THRUST BEARING SIZE-			9.2.5.2.8	817
BEARINGS AND LUBRICATION	PRESSURE LUBE TO API 814 Ch				438
BEARINGS AND LUBRICATION	API 814/ISO 10438-2 DATA SHEETS ATTACHED			9.2.5.4	751
BEARINGS AND LUBRICATION	Pressurized Lube Oil System mounted on same baseplate as pump				804
BEARINGS AND LUBRICATION	Location of Pressurized Lube Oil System mounted on baseplate				755
BEARINGS AND LUBRICATION	INTERCONNECTING PIPING PROVIDED BY				750
BASEPLATE	API BASEPLATE NUMBER-			Annex D	28
BASEPLATE	Baseplate-NonGrout-			7.4.1.e	31
BASEPLATE	BASEPLATE CONSTRUCTION			7.4	708
BASEPLATE	MOUNTING				30
BASEPLATE	Baseplate Drainage			7.4.1	709
BASEPLATE	SUPPLIED WITH -GROUT AND VENT HOLES				844
BASEPLATE	DRAIN CONNECTION				33
BASEPLATE	MOUNTING PADS TO BE MACHINED			7.4.9	789
BASEPLATE	PROVIDE SPACER PLATE UNDER ALL EQUIPMENT FEET			7.4.10	807
BASEPLATE	PROVIDE SOLEPLATE FOR OH3/4S PUMPS			8.1.2	
INSTRUMENTATION	INSTRUMENTATION PER API 870			7.5.2.1	17
INSTRUMENTATION	PROVISIONS ONLY FOR MTG ACCELEROMETERS			8.10.2.13	447
INSTRUMENTATION	FLAT SURFACE REQUIRED-			8.10.2.14	220
INSTRUMENTATION	PROVISIONS ONLY FOR MTG PROX PROBES			8.10.2.13, 8.8.12	448
INSTRUMENTATION	PROXIMITY PROBES REQUIRED			7.5.2.2	
INSTRUMENTATION	NUMBER PER RADIAL BEARING-				472
INSTRUMENTATION	INSTRUMENTATION-NUMBER PER AXIAL BEARING				20
INSTRUMENTATION	MONITORS AND CABLES SUPPLIED BY-			7.5.2.4	51
INSTRUMENTATION	TEMP PROBES REQUIRED			7.5.2.3	
INSTRUMENTATION	RADIAL BEARING TEMP -				471
INSTRUMENTATION	THRUST BEARING TEMP -				805
INSTRUMENTATION	TEMP. GAUGES (WITH THERMOWELLS)-			9.1.3.5	599
INSTRUMENTATION	PRESSURE GAUGE TYPE-				435
INSTRUMENTATION	Number of Accelerometers. 1				789
INSTRUMENTATION	Mounting Location of Accelerometers. 1				785
INSTRUMENTATION	PROVISIONS FOR TEMP PROBES			8.10.2.2	808
INSTRUMENTATION	NUMBER PER RADIAL BEARING				792

Figure N.3—Data List (Continued)



INSTRUMENTATION	NUMBER PER THRUST BEARING ACTIVE SIDE			793
INSTRUMENTATION	NUMBER PER THRUST BEARING INACTIVE SIDE			794
SEAL SUPPORT SYSTEM MOUNTING	SEAL SUPPORT SYSTEM MOUNTED ON PUMP BASEPLATE		7.6.1.4	518
SEAL SUPPORT SYSTEM MOUNTING	Identify Location on Baseplate		7.4.6	743
SEAL SUPPORT SYSTEM MOUNTING	INTERCONNECTING PIPING BY			507
MECHANICAL SEAL	SEE ATTACHED API 682/ISO 21049 DATA SHEET-		6.8	18
MECHANICAL SEAL	HEATING JACKET REQD-		6.8.11	255
MECHANICAL SEAL	ADDITIONAL CENTRAL FLUSH PORT		6.8.9	702
HEATING AND COOLING	COOLING REQD-		6.1.23	90
HEATING AND COOLING	COOLING WATER PIPING PLAN-		7.6.3.1	89
HEATING AND COOLING	COOLING WATER PIPING-			88
HEATING AND COOLING	COOLING WATER PIPING-FITTINGS			86
HEATING AND COOLING	COOLING WATER PIPING MATERIALS-			87
HEATING AND COOLING	COOLING WATER SUPPLY PRESSURE			
HEATING AND COOLING	COOLING WATER REQUIREMENTS-BEARING HOUSING			126
HEATING AND COOLING	COOLING WATER-HEAT EXCHANGER			128
HEATING AND COOLING	TOTAL COOLING WATER-			130
HEATING AND COOLING	HEATING MEDIUM-			256
HEATING AND COOLING	HEATING PIPING-			257
PIPING & APPURTENANCES	MANIFOLD AUX PIPING SYSTEMS		7.6.1.6	304
PIPING & APPURTENANCES	TAG ALL ORIFICES		7.6.2.4	845
PIPING & APPURTENANCES	SOCKET WELD CONN ON SEAL GLAND		7.6.2.8	
SURFACE PREPARATION AND PAINT	MANUFACTURER'S STANDARD-		8.4.3.4	415
SURFACE PREPARATION AND PAINT	OTHER (SEE BELOW)-			416
SURFACE PREPARATION AND PAINT	SPECIFICATION NO-			417
SURFACE PREPARATION AND PAINT	PUMP SURFACE PREPARATION-			484
SURFACE PREPARATION AND PAINT	PUMP PRIMER			460
SURFACE PREPARATION AND PAINT	PUMP FINISH COAT			453
SURFACE PREPARATION AND PAINT	BASEPLATE SURFACE PREPARATION-			36
SURFACE PREPARATION AND PAINT	BASEPLATE PRIMER			35
SURFACE PREPARATION AND PAINT	BASEPLATE FINISH COAT			667
SURFACE PREPARATION AND PAINT	SHIPMENT-		8.4	528
SURFACE PREPARATION AND PAINT	EXPORT BOXING REQUIRED-			215
SURFACE PREPARATION AND PAINT	OUTDOOR STORAGE MORE THAN 6 MONTHS-			408
SURFACE PREPARATION AND PAINT	Rotor Storage Orientation		9.2.8.2	645
SURFACE PREPARATION AND PAINT	N2 PURGE-		9.2.8.4	371
SURFACE PREPARATION AND PAINT	SURFACE PREPARATION AND PAINT		L.3.4.6	554
SURFACE PREPARATION AND PAINT	OTHER PURCHASER REQUIREMENTS		L.3.4.6	553
SURFACE PREPARATION AND PAINT	SHIPPING & STORAGE CONTAINER FOR VERT STORAGE		9.2.8.3	817
WEIGHT	W1-ITEM NUMBER			
WEIGHT	W1-PUMP			456
WEIGHT	W1-BASE			27
WEIGHT	W1-DRIVER			665
WEIGHT	W1-GEAR			666
WEIGHT	W1-TOTAL			621
WEIGHT	W2-ITEM NUMBER			
WEIGHT	W2-PUMP			
WEIGHT	W2-BASE			
WEIGHT	W2-DRIVER			
WEIGHT	W2-GEAR			
WEIGHT	W2-TOTAL			
WEIGHT	W3-ITEM NUMBER			
WEIGHT	W3-PUMP			
WEIGHT	W3-BASE			
WEIGHT	W3-DRIVER			
WEIGHT	W3-GEAR			
WEIGHT	W3-TOTAL			
OTHER PURCHASER REQUIREMENTS	COORDINATION MEETING REQUIRED-			100
OTHER PURCHASER REQUIREMENTS	MAXIMUM DISCHARGE PRESSURE TO INCLUDE-MAX RELATIVE DENSITY		6.3.2	272
OTHER PURCHASER REQUIREMENTS	MAX DIA. IMPELLERS AND/OR NO OF STAGES-		6.3.2	271
OTHER PURCHASER REQUIREMENTS	OPERATION TO TRIP SPEED-		6.3.2	273
OTHER PURCHASER REQUIREMENTS	CONNECTION DESIGN APPROVAL-		9.2.1.4	79
OTHER PURCHASER REQUIREMENTS	TORSIONAL ANALYSIS / REPORT-		6.9.2	618
OTHER PURCHASER REQUIREMENTS	PROGRESS REPORTS-		L.3.3	445
OTHER PURCHASER REQUIREMENTS	OUTLINE OF PROCEDURES FOR OPTIONAL TESTS (10.2.5)		L.2.5	442
OTHER PURCHASER REQUIREMENTS	ADDITIONAL DATA REQUIRING 20 YEARS RETENTION-		8.2.1.1	3
OTHER PURCHASER REQUIREMENTS	LATERAL ANALYSIS REQUIRED-		9.2.4.1.2	283
OTHER PURCHASER REQUIREMENTS	ROTOR DYNAMIC BALANCE CRITERIA		6.9.3.5	189
OTHER PURCHASER REQUIREMENTS	FLANGES REQUIRED IN PLACE OF SOCKET WELD UNIONS			219
OTHER PURCHASER REQUIREMENTS	CONNECTION BOLTING		7.6.1.7	80
OTHER PURCHASER REQUIREMENTS	VENDOR TO KEEP REPAIR AND HT RECORDS-		8.2.1.1.c	638
OTHER PURCHASER REQUIREMENTS	VENDOR SUBMIT TEST PROCEDURES		8.3.1.1	640
OTHER PURCHASER REQUIREMENTS	SUBMIT INSPECTION CHECK LIST-		8.1.5	569
OTHER PURCHASER REQUIREMENTS	VFD STEADY STATE DAMPED RESPONSE ANALYSIS		6.9.2.3	862
OTHER PURCHASER REQUIREMENTS	TRANSIENT FORCED RESPONSE		6.9.2.4	855
OTHER PURCHASER REQUIREMENTS	BEARING LIFE CALCULATIONS REQUIRED		6.10.1.11	711
CONSTRUCTION	IGNITION HAZARD ASSESSMENT TO EN 13463-1		7.3.2.2	744
OTHER PURCHASER REQUIREMENTS	CASING RETIREMENT THICKNESS DRAWING		L.3.6.1 cc)7xxiii)	718
OTHER PURCHASER REQUIREMENTS	ACOUSTIC ANALYSIS OF CROSSOVER PASSAGE		9.2.1.5	
OTHER PURCHASER REQUIREMENTS	API 691 DOCUMENTATION REQUIRED			
TEST	SHOP INSPECTION-		8.1.1.1	530
TEST	PERFORMANCE CURVE & DATA APPROVAL PRIOR TO SHIPMENT.-		8.3.3.4.6	124
TEST	TEST WITH SUBSTITUTE SEAL-		8.3.3.3.1	570
TEST	MATERIAL CERTIFICATION REQUIRED-CASING		6.12.1.8	61
TEST	IMPELLER-CERT		6.12.1.8	265
TEST	SHAFT-Cert		6.12.1.8	524

Figure N.3—Data List (Continued)

TEST	OTHER-CERT			6.12.1.8	404
TEST	CASTING REPAIR WELD PROCEDURE APPROVAL REQUIRED-			6.12.2.5	69
TEST	INSPECTION REQUIRED FOR CONNECTION WELDS-MAG PARTICLE			6.12.3.4	82
TEST	CONNECTION WELDS-RADIOGRAPHY			6.12.3.4	83
TEST	CONNECTION WELDS-LIQUID PENETRANT			6.12.3.4	81
TEST	CONNECTION WELDS-ULTRASONIC			6.12.3.4	84
TEST	HARDNESS TEST REQUIRED-			6.12.1.13	250
TEST	ADDITIONAL SUBSURFACE EXAMINATION			6.12.1.6, 8.2.1.3	678
TEST	Additional Subsurface Exam-FOR				1
TEST	Additional Subsurface Exam-METHOD				2
TEST	HYDROSTATIC -			8.3.2	281
TEST	HYDROSTATIC TEST OF BOWLS & COLUMN-			9.3.13.1	260
TEST	PERFORMANCE TEST-			8.3.3	425
TEST	NPSH-			8.3.4.3	387
TEST	RETEST ON SEAL LEAKAGE-			8.3.3.3.2	512
TEST	RETEST REQUIRED AFTER FINAL HEAD ADJUSTMENT-			8.3.3.8.2	480
TEST	COMPLETE UNIT TEST-			8.3.4.4.1	78
TEST	SOUND LEVEL TEST-			8.3.4.5	546
TEST	CLEANLINESS PRIOR TO FINAL ASSEMBLY-			8.2.2.6	73
TEST	CHECK FOR CO-PLANAR MOUNTING PAD SURFACES-			7.4.8	101
TEST	MECHANICAL RUN TEST UNTIL OIL TEMP STABLE-			8.3.4.2.1	338
TEST	4 HR. MECH RUN AFTER OIL TEMP STABLE-			8.3.4.2.2	337
TEST	BRG HSG RESONANCE TEST-			8.3.4.7	49
TEST	REMOVE / INSPECT HYDRODYNAMIC BEARINGS AFTER TEST-			8.2.7.4	276
TEST	AUXILIARY EQUIPMENT TEST PER-			8.3.4.6	19
TEST	IMPACT TEST-PER EN 13445			6.12.4.3	284
TEST	IMPACT TEST-PER ASME SECTION VIII			6.12.4.3	283
TEST	CASING DISASSEMBLY AFTER TEST			8.3.3.9	487
TEST	PMI TESTING REQUIRED			8.2.2.8	797
TEST	COMPONENTS TO BE TESTED				725
TEST	RESIDUAL UNBALANCE TEST			J.4.1.2	812
TEST	NOTIFICATION OF SUCCESSFUL SHOP PERFORMANCE TEST			8.1.1.3, 8.3.3.4.6	785
TEST	BASEPLATE (NOZZLE LOAD) TEST			7.4.24	710
TEST	TEST DATA POINTS TO			8.3.3.4	850
TEST	ALTERNATE TEST TOLERANCES PER			8.3.3.5	424
TEST	NPSH-1ST STG ONLY			8.3.4.3.2	788
TEST	TEST NPSHA LIMITED TO 110% SITE NPSHA			8.3.3.7	652
TEST	LOCATION OF CLEANLINESS INSPECTION				754
TEST	STRUCTURAL RESONANCE TEST			9.3.9.2	830
TEST	LOCATION OF AUXILIARY EQUIPMENT TEST				753
TEST	Equipment to be Included in Auxiliary Tests				1746
VERTICAL PUMPS	VERTICAL TYPE			4.2.2	
VERTICAL PUMPS	STATIC THRUST-UP				559
VERTICAL PUMPS	STATIC THRUST-DOWN				558
VERTICAL PUMPS	AT MIN. FLOW-UP				614
VERTICAL PUMPS	AT MIN. FLOW-DOWN				613
VERTICAL PUMPS	AT RATED FLOW-UP				616
VERTICAL PUMPS	AT RATED FLOW-DOWN				615
VERTICAL PUMPS	AT MAX. FLOW-UP				611
VERTICAL PUMPS	AT MAX. FLOW-DOWN				610
VERTICAL PUMPS	MAX THRUST-UP				612
VERTICAL PUMPS	MAX THRUST-DOWN				609
CONSTRUCTION & VERTICAL PUMPS	SOLEPLATE REQD-			9.3.8.3.2	541
VERTICAL PUMPS	SOLEPLATE-LENGTH				540
VERTICAL PUMPS	SOLEPLATE-WIDTH				543
VERTICAL PUMPS	SOLEPLATE-THICKNESS				542
VERTICAL PUMPS	COLUMN PIPE-				75
VERTICAL PUMPS	COLUMN PIPE-DIAMETER				644
VERTICAL PUMPS	COLUMN PIPE-LENGTH				76
VERTICAL PUMPS	GUIDE BUSHING-NUMBER				248
VERTICAL PUMPS	GUIDE BUSHING-LINE SHAFT BEARING SPACING				230
VERTICAL PUMPS	GUIDE BUSHING-LUBE				247
VERTICAL PUMPS	LINESHAFT-				286
VERTICAL PUMPS	LINESHAFT DIAMETER-				289
VERTICAL PUMPS	TUBE DIAMETER-				628
VERTICAL PUMPS	LINESHAFT CONNECTION-				287
VERTICAL PUMPS	SUCTION CAN-THICKNESS				572
VERTICAL PUMPS	SUCTION CAN-LENGTH				571
VERTICAL PUMPS	SUCTION CAN-DIAMETER				574
VERTICAL PUMPS	SUCTION STRAINER TYPE-				582
VERTICAL PUMPS	LEVEL CONTROL-				284
VERTICAL PUMPS	IMPELLER COLLETS ACCEPTABLE-			6.6.3	286
VERTICAL PUMPS	HARDENED SLEEVES UNDER BEARINGS-			9.3.10.4	251
VERTICAL PUMPS	SEPARATE MOUNTING PLATE			9.3.8.3.1	548
VERTICAL PUMPS	COLUMN PIPE-NUMBER				722
VERTICAL PUMPS	COLUMN PIPE-SPACING				723
VERTICAL PUMPS	STRUCTURAL ANALYSIS			9.3.5	829
VERTICAL PUMPS	CAN DRAIN PIPED TO SURFACE			9.3.13.4	752
VERTICAL PUMPS	ELLIPTICAL BOTTOM HEAD REQUIRED			9.3.2.5	
VERTICAL PUMPS	PRESSURE CASING WALLS USE SEAMLESS PIPE			9.3.2.7	
MATERIALS (additional)	SUCTION CAN / BARREL				843
MATERIALS (additional)	DISCHARGE HEAD				837
MATERIALS (additional)	BOWL SHAFT				835
MATERIALS (additional)	LINESHAFT				838
MATERIALS (additional)	LINESHAFT HARDFACING				840
MATERIALS (additional)	BELLMOUTH				833
MATERIALS (additional)	BOWL BEARING				834

Figure N.3—Data List (Continued)

MATERIALS (additional)	LINESHAFT BEARING				839
MATERIALS (additional)	LINESHAFT SLEEVES				841
MATERIALS (additional)	BEARING RETAINER				832
MATERIALS (additional)	SHAFT ENCLOSING TUBE				842
MATERIALS (additional)	DISCHARGE COLUMN				836
MATERIALS (additional)	PRESSURE RATING HEAD-MAWP				803
MATERIALS (additional)	PRESSURE RATING HEAD-HYDRO				802
MATERIALS (additional)	COLUMN PIPE-MAWP				721
MATERIALS (additional)	COLUMN PIPE-HYDRO				720
MATERIALS (additional)	BOWL-MAWP				716
MATERIALS (additional)	BOWL-HYDRO				715
MATERIALS (additional)	Discharge Head Material				1747
SUMP ARRANGEMENTS	GRADE ELEVATION-1				243
SUMP ARRANGEMENTS	LOW LIQUID LEVEL-2				296
SUMP ARRANGEMENTS	C.L. OF DISCHARGE-3				142
SUMP ARRANGEMENTS	SUMP DEPTH-I1				583
SUMP ARRANGEMENTS	PUMP LENGTH-I2				455
SUMP ARRANGEMENTS	GRADE TO DISCH-I3				245
SUMP ARRANGEMENTS	GRADE TO LOW LIQUID LVL-I4				246
SUMP ARRANGEMENTS	GRADE TO 1ST STG IMPLR-I6				244
SUMP ARRANGEMENTS	SUBMERGENCE REQ'D-I6				588
SUMP ARRANGEMENTS	SUMP DIAMETER-Ød				584
PRESSURE VESSEL DESIGN CODE REFER	CASTING FACTORS USED IN DESIGN (TABLE 4)				486
PRESSURE VESSEL DESIGN CODE REFER	SOURCE OF MATERIAL PROPERTIES-		6.3.5		309
WELDING AND REPAIRS	AllWeldingStandards-		6.12.3.1		9
WELDING AND REPAIRS	Welding Requirement				662
WELDING AND REPAIRS	WELDER/OPERATOR QUALIFICATION-				651
WELDING AND REPAIRS	WELDING PROCEDURE QUALIFICATION-				652
WELDING AND REPAIRS	NON-PRESSURE RETAINING STRUCTURAL WELDING SUCH AS BASEPLATES OR SUPPORTS-				380
WELDING AND REPAIRS	MAGNETIC PARTICLE OR LIQUID PENETRANT EXAMINATION OF PLATE EDGES-				302
WELDING AND REPAIRS	POSTWELD HEAT TREATMENT-				430
WELDING AND REPAIRS	POSTWELD HEAT TREATMENT OF CASING FABRICATION WELDS-				429
MATERIAL INSPECTION	MATL INSPECTION DEFAULT TO TABLE 14			Table 15; § 2.2	684
MATERIAL INSPECTION	RADIOGRAPHY-METHOD				475
MATERIAL INSPECTION	RADIOGRAPHY-FOR FABRICATIONS				474
MATERIAL INSPECTION	RADIOGRAPHY-FOR CASTINGS				473
MATERIAL INSPECTION	ULTRASONIC INSPECTION-METHOD				634
MATERIAL INSPECTION	ULTRASONIC-FOR FABRICATIONS				633
MATERIAL INSPECTION	ULTRASONIC-FOR CASTINGS				632
MATERIAL INSPECTION	MAGNETIC PARTICLE INSPECTION-METHOD				301
MATERIAL INSPECTION	MAGNETIC-FOR FABRICATIONS				300
MATERIAL INSPECTION	MAGNETIC-FOR CASTINGS				298
MATERIAL INSPECTION	LIQUID PENETRANT INSPECTION-METHOD				292
MATERIAL INSPECTION	LIQUID-FOR FABRICATIONS				291
MATERIAL INSPECTION	LIQUID-FOR CASTINGS				290
MATERIAL INSPECTION	VISUAL INSPECTION-METHOD				863
MATERIAL INSPECTION	VISUAL-FOR FABRICATIONS				758
MATERIAL INSPECTION	VISUAL-FOR CASTINGS				757
NOTES	Notes Page				784

Figure N.3—Data List (Continued)

ProjectDesignData				DOCUMENT NUMBER:					
				REVISION	0	1	2	3	4
				DATE					
				BY					
				REV/APPR					
<p align="center"><b>PROJECT DESIGN DATA SHEET</b></p> <p align="center"><b>U.S. CUSTOMARY</b></p>				JOB NO.	PAGE 1 OF 1				
				CLIENT					
				LOCATION					
				UNIT NO.					
				ITEM NO.					
APPLICABLE TO: <input checked="" type="checkbox"/> PROPOSAL <input type="checkbox"/> PURCHASE <input type="checkbox"/> AS BUILT				REQ'N NO.					
<b>SITE DESIGN CONDITIONS</b>									
AMBIENT DRY BULB TEMPERATURE				RAINFALL / SNOWFALL (in)					
Average Annual (Summer / Winter) (°F)				Average, Annual Rainfall		Max 24 Hour Period			
Site Maximum (Design) (°F)				Average, Annual Snowfall					
Site Minimum (Design) (°F)				SNOW AND ICE LOADING					
Design Basis - Air Cooled Exchangers (°F)				Ground Snow Load (in)					
RELATIVE HUMIDITY (%)				RAW WATER SOURCE:					
Average @ (°F)				Temperature: (min/max/design) (°F)					
Maximum @ (°F)				EARTHQUAKE LOADING:					
Minimum @ (°F)				Design Code:					
BAROMETRIC PRESSURE (MAX/MIN) mmHg				Seismic Zone:		Importance Factor:			
SOLAR RADIATION (Heat Flux Intensity) (BTU/ft²)				Short Period Acceleration (S <sub>g</sub> ) in %g:					
SITE ELEVATION (ft)				DESIGN WIND SPEED, 3 sec gust: (mph)					
SITE CONDITIONS:				Wind Design Code:		Site Class:			
				Exposure Category:					
<b>UTILITIES</b>									
STEAM					ELECTRICAL POWER				
Pressure (psig)	Rated	Max/Min	Mech Design	MOTORS			Voltage	Phase	Hertz
High-high				Low Volt: <=	(HP)				
High				Med Volt: >	& . (HP)				
Medium				High Volt: >	& . (HP)				
Low				High-High Volt: >	(HP)				
Temperature (°F)	Rated	Max/Min	Mech Design	Fractional <=	(HP)				
High-high				HEATERS (incl Lube Oil):					
High				>	(kW)				
Medium				<=	(kW)				
Low				Motor Space Htrs > (kW)					
AIR & NITROGEN				Motor Space Htrs < (kW)					
Pressure (psig)		Temperature (°F)		Heaters for panels					
	Min	Normal	Design	Normal	Design				
Instrument						MISCELLANEOUS ELECTRICAL			
Plant Air						Normal Lighting			
Nitrogen (LP)						U.P.S. - Controls			
Nitrogen (HP)						U.P.S. - Critical Equip			
Remarks						Instrument Circuits			
COOLING WATER				Shutdown / Alarm - Instr.					
	Press (psig)	Temp (°F)		Emergency Generator					
Maximum (Supply/Return)				Other					
Minimum (Supply/Return)									
Max. Differential Temperature				Digital I/O Signals:					
Allowable Differential Pressure				Analog I/O Signals:					
System Mech Design									
Source									
REMARKS:									

Figure N.4—API Project Design Data Sheet

## **Annex O** (informative)

### **Special-purpose Centrifugal Pumps**

#### **O.1 Definition**

A special-purpose centrifugal pump is one that meets one or more of the following criteria:

- a) operating in a severe, critical application;
- b) a prototype—a design that is sufficiently different from existing designs to warrant, in either the manufacturer's or the purchaser's opinion, the extent of engineering analysis and manufacturing process specified in this Annex O;
- c) high energy levels.

**NOTE** "High energy" is a term that has been used by some in the oil and gas industry to define if a design requires more attention to engineering and manufacturing than is required by API 610. "High energy" has myriad definitions (shaft power, power per stage, head per stage, pressure rise per stage, value of first stage impeller inlet peripheral velocity), none of which are sufficiently encompassing to qualify as a single definition.

#### **O.2 Selection**

##### **O.2.1 Pressure Boundary Type Selection**

Determine pressure boundary configuration (axially or radially split) following rules of API 610 unless purchaser's specification requires otherwise.

##### **O.2.2 Inner Casing (Type BB5 Multistage Pumps) Selection**

For type BB5 barrel pumps, specify the inner case requirements:

- a) radially split (generically "diffuser"),
- b) axially split (generically "volute").

##### **O.2.3 Rotor Selection**

Determine/specify rotor requirements using the following criteria and guidelines.

**O.2.3.1** For one and two stage pumps, follow rules of API 610 for rotor stiffness.

**O.2.3.2** For multistage pumps (type BB3 and BB5 pumps), apply O.2.3.2.1 or O.2.3.2.2 as applicable.

**O.2.3.2.1** Follow rules of API 610. Step the shaft diameter at each impeller for ease of assembly and disassembly.

**O.2.3.2.2** If agreed by the purchaser and the vendor, the pump rotor can be designed for stiffness based on: static deflection with the rotor centered in its end clearances which provides static radial clearance at mid-span  $\geq 0.30$  of the minimum new diametral clearance at rotor mid-span.

## O.3 Design

### O.3.1 General

The design of such pumps often requires more purchaser and vendor interface than normal pumps described in the body of API 610. The following are recommended discussion points and reviews that are to be mutually agreed by the parties and reflected in the final purchase specification.

### O.3.2 Overall Design Review

A more detailed overall review of the pump and its desired operating points and characteristics is often required. A thorough understanding of the pump and other components that make up the pump-driver package is essential. The parties will define documentation and inspection requirements that go beyond API 610 normal requirements. Below is a partial list:

- a) conceptual design and predicted hydraulic performance;
- b) detailed mechanical layout;
- c) review of all engineering reports, major detail drawings, purchase specifications, relevant inspections, and test procedures;
- d) a design failure mode and effect analysis (DFMEA) as described in 6.1.3.1 and API 691.

### O.3.3 Pressure Boundary Design Review

The parties will determine if the pressure boundary design will follow the “design by rule” method of API 610 or a “design by analysis” method.

**O.3.3.1** The “design by rule” method is in the body of API 610.

**O.3.3.2** The “design by analysis” method establishes the design by finite element analysis (FEA) analysis conducted at hydrostatic test pressure in 8.3.2 (ASME *BPVC* Section VIII, Division 2) based upon the following:

- a) allowable local stress for 20 year fatigue life considering pressure and temperature variations,
- b) required distribution of residual stress in metal-to-metal sealing surfaces,
- c) allowable deflection at critical fits,
- d) allowable changes of running clearances caused by casing or component deflections.

NOTE A different hydrostatic test multiplier is sometimes agreed.

### O.3.4 Impeller(s) Design Review

At high energy levels, hydraulic forces can become substantial. The parties will define and agree upon the impeller design requirements. A partial list of suggested topics follows below.

**O.3.4.1** First stage: Consider the use of NPSH3 or incipient NPSH (NPSHi) and effect on impeller life.

**O.3.4.2** All stages: If head/stage  $\geq 500$  m (1640 ft), consider the following:

- a) structural analysis to determine shroud natural frequencies, wet mode shapes, and potential for resonance-separation on interference diagram  $\geq 10$  %;

- b) structural analysis with hydraulic loading, including effect of operating flow range and impeller to collector vane tip clearance, to verify impeller fatigue life at rated speed allowing for effect of number of cycles on endurance strength.

### **O.3.5 Diffuser(s) or Volute(s) Review**

Like the impellers above, the stationary hydraulic components also see substantial hydraulic forces in high-energy pumps. If head/stage  $\geq 1640$  ft (500 m), structural analysis of the diffusers or volutes similar to but simpler than impellers should be performed.

### **O.3.6 Shaft Seals Review**

Special-purpose pumps can have large shafts at high speed or can have other duties that are beyond normal mechanical seal operating parameters. For such pumps, the parties are to consider the following steps in seal selection and especially prototype testing:

- a) abide by requirements of API 610 and API 682 where applicable,
- b) consider dry gas seals (DGSs) for light hydrocarbons below 0.70 specific gravity (as referenced on Table 14) and CO<sub>2</sub>,
- c) consider API 682 qualification test of prototype seals to establish seal performance before releasing for manufacture.

### **O.3.7 Bearing Type and Design Review**

Consider operating history of planned bearing types and lubrication system. Follow API 610 and API 614 for established bearing and lubrication system designs, and select subvendors with applicable operating history. If new designs or new subvendors are selected, qualification test of prototypes to establish performance should be considered before releasing for manufacture.

### **O.3.8 Bearing Housing Review**

Bearing housing resonance and other issues can be troublesome during performance test and cause other issues. For established design with applicable operating history, follow API 610. If new design, determine by FEA the natural frequencies of housing(s) bolted to pump casing.

### **O.3.9 Condition Monitoring and Other Instrumentation Review**

Consider the level of instrumentation for condition monitoring, and uniformity of pump warm-up or cooldown before operation. Plan for or include provisions for measurements that might be useful in troubleshooting.

## **O.4 Manufacture**

### **O.4.1 General**

Due to the often critical nature of such special-purpose pumps, greater attention to manufacturing processes can be deemed advisable. Below is a partial list of such processes and discussion points that can be considered by purchaser and vendor.

### **O.4.2 Pressure Boundary Manufacture**

#### **O.4.2.1 Castings should consider the following.**

- a) Verify castability as designed and rigged with solidification modeling.

- b) Verify heat treatment of all stainless steel castings.
- c) Nondestructive testing (NDT)—Refer to 8.2.2.1, Table 14. Verify with foundry to ensure molding design reflects required quality level and needed test coupons.
- d) Verify all welding procedures used for manufacturing, repair, and fabrications applicable to the materials provided.

**O.4.2.2** Forgings should consider the following.

- a) Verify heat treatment of all stainless steel forgings.
- b) NDT—Refer to 8.2.2.1, Table 14. Verify with foundry to ensure molding design reflects required quality level and needed test coupons.
- c) Verify all welding procedures used for manufacturing, repair, and fabrications applicable to the materials provided

### **O.4.3 Impeller(s) Manufacture**

Special-purpose pumps often utilize precision cast impellers to control hydraulic forces and flow, as well as provide improved interior surface finish.

- a) Verify heat treatment of all stainless steel castings.
- b) NDT—consider MT or PT of accessible areas. Consider dimensional and template checks of highly stressed critical areas, flow areas, vane spacing, and vane angles.

### **O.4.4 Shaft Manufacture**

Both parties should agree upon barstock or forging production by appropriate method.

**O.4.4.1** Refer to 8.2.2.1, Table 15. Consider NDT, heat treating methods, and test coupons required.

**O.4.4.2** Machine to produce finished shaft with runout of critical fits within allowable limits—can be lower than allowed by body of API 610.

### **O.4.5 Diffuser(s) Manufacture**

If a diffuser design pump was selected in O.2.2 above, there are two usual diffuser designs as listed below. In either case, verify the hydraulic and mechanical dimensions.

**O.4.5.1** Diffuser integral—machined into cast stage piece—treat as pressure boundary casting in O.4.2.1 above.

**O.4.5.2** Diffuser separate—precision cast, machined then attached to semi-finished stage piece—treat diffuser as impeller; treat balance of stage piece as pressure boundary casting in O.4.2.1 above.

### **O.4.6 Volute(s) Manufacture**

If an axially split inner casing type of BB5 pump was selected in O.2.2 above, treat inner case castings as pressure boundary casting in O.4.2.1 above. Verify hydraulic and mechanical dimensions.

### **O.4.7 Shaft Seal Manufacture**

See O.3.6 above.



### **O.4.8 Bearing Manufacture**

See O.3.7 above.

### **O.4.9 Bearing Housing Manufacture**

If bearing housings are castings, treat as pressure boundary casting in O.4.2.1 above. If new design, perform resonance test when assembled to confirm FEA in O.3.8 above.

### **O.4.10 Testing**

Due to the often critical nature of such special-purpose pumps, greater attention to testing and possibly more extensive testing can be deemed advisable. A few such testing topic discussion points that can be considered by purchaser and vendor are given in O.4.10.1 and O.4.10.2.

**O.4.10.1** Engineering/development testing points for discussion are as follows:

- a) prototype test of one or two stages if deemed necessary to check hydraulic design before releasing for manufacture;
- b) verify NPSHi if required by manufacturer or purchaser's specification;
- c) test complete pump with maximum diameter impellers to verify performance (head and power vs flow; rotor residual axial thrust and mechanical operation);
- d) perform additional testing required by manufacturer or purchaser's specification;
- e) test complete pump with impellers cut to diameter for rated performance, then perform a 4 h run test per 8.3.4.2.2.

**O.4.10.2** Contract/witness test of pump with rated impellers is often specified.

## Bibliography

- [1] ISO 185 <sup>18</sup>, *Grey cast irons—Classification*
- [2] ISO 683-1, *Heat-treatable steels, alloy steels and free-cutting steels—Part 1: Non-alloy steels for quenching and tempering*
- [3] ISO 683-18, *Heat-treatable steels, alloy steels and free-cutting steels—Part 18: Bright steel products*
- [4] ISO 3448, *Industrial liquid lubricants—ISO viscosity classification*
- [5] ISO 3506-1, *Mechanical properties of corrosion-resistant stainless-steel fasteners—Part 1: Bolts, screws and studs with specified grades and property classes*
- [6] ISO 3506-2, *Mechanical properties of corrosion-resistant stainless-steel fasteners—Part 2: Nuts with specified grades and property classes*
- [7] ISO 3740, *Acoustics—Determination of sound power levels of noise sources—Guidelines for the use of basic standards*
- [8] ISO 3744, *Acoustics—Determination of sound power levels and sound energy levels of noise sources using sound pressure—Engineering methods for an essentially free field over a reflecting plane*
- [9] ISO 3746, *Acoustics—Determination of sound power levels and sound energy levels of noise sources using sound pressure—Survey method using an enveloping measurement surface over a reflecting plane*
- [10] ISO 4991, *Steel castings for pressure purposes*
- [11] ISO 9329-2, *Seamless steel tubes for pressure purposes—Technical delivery conditions—Part 2: Unalloyed and alloyed steels with specified elevated temperature properties*
- [12] ISO 9905, *Technical specifications for centrifugal pumps—Class I*
- [13] ISO 15156-2, *Petroleum and natural gas industries—Materials for use in H<sub>2</sub>S-containing environments in oil and gas production—Part 2: Cracking-resistant carbon and low alloy steels, and the use of cast irons*
- [14] ISO 15156-3, *Petroleum and natural gas industries—Materials for use in H<sub>2</sub>S-containing environments in oil and gas production—Part 3: Cracking-resistant CRAs (corrosion-resistant alloys) and other alloys*
- [15] EN 1561 <sup>19</sup>, *Founding—Grey cast irons*
- [16] EN 1759-1, *Flanges and their joints—Circular flanges for pipes, valves, fittings and accessories, Class designated—Part 1: Steel flanges, NPS 1/2 to 24*
- [17] EN 10028-3, *Flat products made of steels for pressure purposes—Part 3: Weldable fine grain steels, normalized*

---

<sup>18</sup> International Organization for Standardization, 1, ch. de la Voie-Creuse, Case postale 56, CH-1211 Geneva 20, Switzerland, [www.iso.org](http://www.iso.org).

<sup>19</sup> European Committee for Standardization (CEN-CENELEC), Avenue Marnix 17, B-1000 Brussels, Belgium, [www.cen.eu](http://www.cen.eu).

- [18] EN 10028-7, *Flat products made of steels for pressure purposes—Part 7: Stainless steels*
- [19] EN 10083-1, *Steels for quenching and tempering—Part 1: General technical delivery conditions*
- [20] EN 10083-2, *Steels for quenching and tempering—Part 2: Technical delivery conditions for non alloy steels*
- [21] EN 10088-2, *Stainless steels—Part 2: Technical delivery conditions for sheet/plate and strip of corrosion resisting steels for general purposes*
- [22] EN 10088-3, *Stainless steels—Part 3: Technical delivery conditions for semi-finished products, bars, rods, wire, sections and bright products of corrosion resisting steels for general purposes*
- [23] EN 10095, *Heat resisting steels and nickel alloys*
- [24] EN 10208-1, *Steel pipes for pipelines for combustible fluids—Technical delivery conditions—Part 1: Pipes of requirement class A*
- [25] EN 10213, *Steel castings for pressure purposes*
- [26] BSI/BS/EN 10213-4, *Technical Delivery Conditions for Steel Castings for Pressure Purposes—Part 4: Austenitic and Austenitic-Ferritic Steel Grades (Q)*
- [27] EN 10222-2, *Steel forgings for pressure purposes—Part 2: Ferritic and martensitic steels with specified elevated temperature properties*
- [28] EN 10222-5, *Steel forgings for pressure purposes—Part 5: Martensitic, austenitic and austenitic-ferritic stainless steels*
- [29] BS/EN 10250-4, *Open die steel forgings for general engineering purposes—Part 4: Stainless steels*
- [30] EN 10269, *Steels and nickel alloys for fasteners with specified elevated and/or low temperature properties*
- [31] EN 10272, *Stainless steel bars for pressure purposes*
- [32] EN 10273, *Hot rolled weldable steel bars for pressure purposes with specified elevated temperature properties*
- [33] EN 10283, *Corrosion resistant steel castings*
- [34] ANSI <sup>20</sup>/ABMA 9 <sup>21</sup>, *Load Ratings and Fatigue Life for Ball Bearings*
- [35] ANSI/ABMA 20, *Radial Bearings of Ball, Cylindrical Roller and Spherical Roller Types—Metric Design*
- [36] ANSI/ASME B1.20.1 <sup>22</sup>, *Pipe Threads, General Purpose (Inch)*
- [37] ANSI/ASME B17.1, *Keys and Keyseats*

---

<sup>20</sup> American National Standards Institute, 25 West 43rd Street, 4th Floor, New York, New York 10036, [www.ansi.org](http://www.ansi.org).

<sup>21</sup> American Bearing Manufacturers Association, 1001 N. Fairfax Street, Suite 500, Alexandria, VA 22314, [www.americanbearings.org](http://www.americanbearings.org).

<sup>22</sup> ASM International, 9639 Kinsman Road, Materials Park, Ohio 44073, [www.asminternational.org](http://www.asminternational.org).

- [38] ANSI/HI 9.6.7 <sup>23</sup>, *Rotodynamic Pumps —Guideline for Effects of Liquid Viscosity on Performance*
- [39] API Recommended Practice 500, *Recommended Practice for Classification of Locations for Electrical Installations at Petroleum Facilities Classified as Class I, Division 1 and Division 2*
- [40] API Recommended Practice 684, *API Standard Paragraphs Rotordynamic Tutorial: Lateral Critical Speeds, Unbalance Response, Stability, Train Torsionals, and Rotor Balancing*
- [41] API Standard 685, *Sealless Centrifugal Pumps for Petroleum, Petrochemical, and Gas Industry Process Service*
- [42] API Recommended Practice 686, *Recommended Practice for Machinery Installation and Installation Design*
- [43] API Recommended Practice 691, *Risk-based Machinery Management*
- [44] ASTM A48/A48M <sup>24</sup>, *Standard Specification for Gray Iron Castings*
- [45] ASTM A53/A53M, *Standard Specification for Pipe, Steel, Black and Hot-Dipped, Zinc-Coated, Welded and Seamless*
- [46] ASTM A105/A105M, *Standard Specification for Carbon Steel Forgings for Piping Applications*
- [47] ASTM A106/A106M, *Standard Specification for Seamless Carbon Steel Pipe for High-Temperature Service*
- [48] ASTM A153/A153M, *Standard Specification for Zinc Coating (Hot-Dip) on Iron and Steel Hardware*
- [49] ASTM A182/A182M, *Standard Specification for Forged or Rolled Alloy and Stainless Steel Pipe Flanges, Forged Fittings, and Valves and Parts for High-Temperature Service*
- [50] ASTM A193/A193M, *Standard Specification for Alloy-Steel and Stainless Steel Bolting Materials for High Temperature or High Pressure Service and Other Special Purpose Applications*
- [51] ASTM A194/A194M, *Standard Specification for Carbon Steel, Alloy Steel, and Stainless Steel Nuts for Bolts for High Pressure or High Temperature Service, or Both*
- [52] ASTM A216/A216M, *Standard Specification for Steel Castings, Carbon, Suitable for Fusion Welding, for High-Temperature Service*
- [53] ASTM A240/A240M, *Standard Specification for Chromium and Chromium-Nickel Stainless Steel Plate, Sheet, and Strip for Pressure Vessels and for General Applications*
- [54] ASTM A266/266M, *Standard Specification for Carbon Steel Forgings for Pressure Vessel Components*
- [55] ASTM A276, *Standard Specification for Stainless Steel Bars and Shapes*
- [56] ASTM A278/A278M, *Standard Specification for Gray Iron Castings for Pressure-Containing Parts for Temperatures up to 650 °F (350 °C)*
- [57] ASTM A312/A312M, *Standard Specification for Seamless, Welded, and Heavily Cold Worked Austenitic Stainless Steel Pipes*

---

<sup>23</sup> Hydraulic Institute, 6 Campus Drive, First Floor North, Parsippany, New Jersey 07054-4406, [www.pumps.org](http://www.pumps.org).

<sup>24</sup> ASTM International, 100 Barr Harbor Drive, West Conshohocken, Pennsylvania 19428, [www.astm.org](http://www.astm.org).

- [58] ASTM A351/A351M, *Standard Specification for Castings, Austenitic, for Pressure-Containing Parts*
- [59] ASTM A352/A352M, *Standard Specification for Steel Castings, Ferritic And Martensitic, for Pressure-Containing Parts, Suitable for Low-Temperature Service*
- [60] ASTM A403/A403M, *Standard Specification for Wrought Austenitic Stainless Steel Piping Fittings*
- [61] ASTM 426/426M, *Standard Specification for Centrifugally Cast Ferritic Alloy Steel Pipe for High-Temperature Service*
- [62] ASTM A434, *Standard Specification for Steel Bars, Alloy, Hot-Wrought or Cold-Finished, Quenched and Tempered*
- [63] ASTM A473, *Standard Specification for Stainless Steel Forgings*
- [64] ASTM A479/A479M, *Standard Specification for Stainless Steel Bars and Shapes for Use in Boilers and Other Pressure Vessels*
- [65] ASTM A487/A487M, *Standard Specification for Steel Castings Suitable for Pressure Service*
- [66] ASTM A516/A516M, *Standard Specification for Pressure Vessel Plates, Carbon Steel, for Moderate- and Lower-Temperature Service*
- [67] ASTM A576, *Standard Specification for Steel Bars, Carbon, Hot-Wrought, Special Quality*
- [68] ASTM A582/A582M, *Standard Specification for Free-Machining Stainless Steel Bars*
- [69] ASTM A696, *Standard Specification for Steel Bars, Carbon, Hot-Wrought or Cold-Finished, Special Quality, for Pressure Piping Components*
- [70] ASTM A743/A743M, *Standard Specification for Castings, Iron-Chromium, Iron-Chromium-Nickel, Corrosion Resistant, for General Application*
- [71] ASTM A790/A790M, *Standard Specification for Seamless and Welded Ferritic/Austenitic Stainless Steel Pipe*
- [72] ASTM A890/A890M, *Standard Specification for Castings, Iron-Chromium-Nickel-Molybdenum Corrosion-Resistant, Duplex (Austenitic/Ferritic) for General Application*
- [73] ASTM A995/A995M, *Standard Specification for Castings, Austenitic-Ferritic (Duplex) Stainless Steel, for Pressure-Containing Parts*
- [74] ASTM B444, *Standard Specification for Nickel-Chromium-Molybdenum-Columbium Alloys (UNS N06625 and UNS N06852) and Nickel-Chromium-Molybdenum-Silicon Alloy (UNS N06219) Pipe and Tube*
- [75] HI 50.7, *Electronic Data Exchange for Pumping Equipment*
- [76] JIS B 2312, *Steel butt-welding pipe fittings*
- [77] JIS G 3106 <sup>25</sup>, *Rolled steels for welded structures*
- [78] JIS G 3202, *Carbon steel forgings for pressure vessels*

---

<sup>25</sup> Japanese Industrial Standards, 1-3-1 Kasumigaseki, Chiyoda-ku, Tokyo 100-8901, Japan, [www.jisc.go.jp/eng](http://www.jisc.go.jp/eng).

- [79] JIS G 3214, *Stainless steel forgings for pressure vessels*
- [80] JIS G 3456, *Carbon steel pipes for high temperature service*
- [81] JIS G 3459, *Stainless steel pipes*
- [82] JIS G 4051, *Carbon steels for machine structural use*
- [83] JIS G 4105, *Chromium molybdenum steels*
- [84] JIS G 4107, *Alloy steel bolting materials for high temperature service*
- [85] JIS G 4303, *Stainless steel bars*
- [86] JIS G 4304, *Hot-rolled stainless steel plate, sheet and strip*
- [87] JIS G 4305, *Cold-rolled stainless steel plate, sheet and strip*
- [88] JIS G 4319, *Stainless steel blooms and billets for forgings*
- [89] JIS G 5121, *Corrosion-resistant cast steels for general applications*
- [90] JIS G 5501, *Grey iron castings*
- [91] JIS G 5151, *Steel castings for high temperature and high pressure service*
- [92] NACE <sup>26</sup>, *Corrosion Engineer's Reference Book*
- [93] ISO 7-1, *Pipe threads where pressure-tight joints are made on the threads—Part 1: Dimensions, tolerances and designation*
- [94] ISO/TR 17766, *Centrifugal pumps handling viscous liquids—Performance corrections*
- [95] ISO 724, *ISO general-purpose metric screw threads—Basic dimensions*
- [96] ISO 965 (all parts), *ISO general-purpose metric screw threads—Tolerances*
- [97] NFPA 70:2008 <sup>27</sup>, *National Electrical Code*
- [98] ASTM D4304, *Standard Specification for Mineral and Synthetic Lubricating Oil Used in Steam or Gas Turbines*
- [99] ASTM E1003, *Standard Practice for Hydrostatic Leak Testing*
- [100] HI 9.6.8, *Rotodynamic Pumps—Guideline for Dynamics of Pumping Machinery*
- [101] ISO 683-13, *Heat-treatable steels, alloy steels and free-cutting steels—Part 13: Wrought stainless steels*
- [102] ISO 8068, *Lubricants, industrial oils and related products (class L)—Family T (Turbines)—Specification for lubricating oils for turbines*
- [103] ISO 10684, *Fasteners—Hot dip galvanized coatings*

---

<sup>26</sup> NACE International, 15835 Park Ten Place, Houston, Texas 77084, [www.nace.org](http://www.nace.org).

<sup>27</sup> National Fire Protection Association, 1 Batterymarch Park, Quincy, Massachusetts 02169-7471, [www.nfpa.org](http://www.nfpa.org).

- 
- [104] ISO 2604-2, *Steel products for pressure purposes—Quality requirements—Part 2: Wrought seamless tubes*
- [105] ISO 9328-4, *Steel flat products for pressure purposes—Technical delivery conditions—Part 4: Nickel-alloy steels with specified low temperature properties*
- [106] ISO 9327-5, *Steel forgings and rolled or forged bars for pressure purposes—Technical delivery conditions—Part 5: Stainless Steels*
- [107] ISO 9328-5, *Steel flat products for pressure purposes—Technical delivery conditions—Part 5: Weldable fine grain steels, thermomechanically rolled*







200 Massachusetts Avenue, NW  
Suite 1100  
Washington, DC 20001-5571  
USA

202-682-8000

**Additional copies are available online at [www.api.org/pubs](http://www.api.org/pubs)**

Phone Orders: 1-800-854-7179 (Toll-free in the U.S. and Canada)  
303-397-7956 (Local and International)

Fax Orders: 303-397-2740

Information about API publications, programs and services is available on the web at [www.api.org](http://www.api.org).

**Product No. C61012**