



# Instrumentation

---

Symbols (P&ID)

# TYPES OF P & IDs

---

- PFD (Process Flow Diagram)
- MFD (Metallurgical Flow Diagram)
- P&ID (Piping & Instrument Diagram)
- |   |                                     |
|---|-------------------------------------|
| = | P&ID Legend                         |
|   | (Drawing which detail symbols used) |
- UFD (Utility Flow Diagram)
- AFD (Auxiliary Flow Diagram)



# P & ID DEFINITION

---

- ↳ P&ID is a detailed graphical representation of a process including the hardware and software necessary to design, construct and operate the facility.
  - Process Industry Practices (PIP)

# P & ID Requirements

---

- └─H Process Flow Diagram (PFD)
- └─H Project Statement
- └─H Process Data Sheet
- └─H Temperature and Pressure Diagram

# Process Flow Diagram

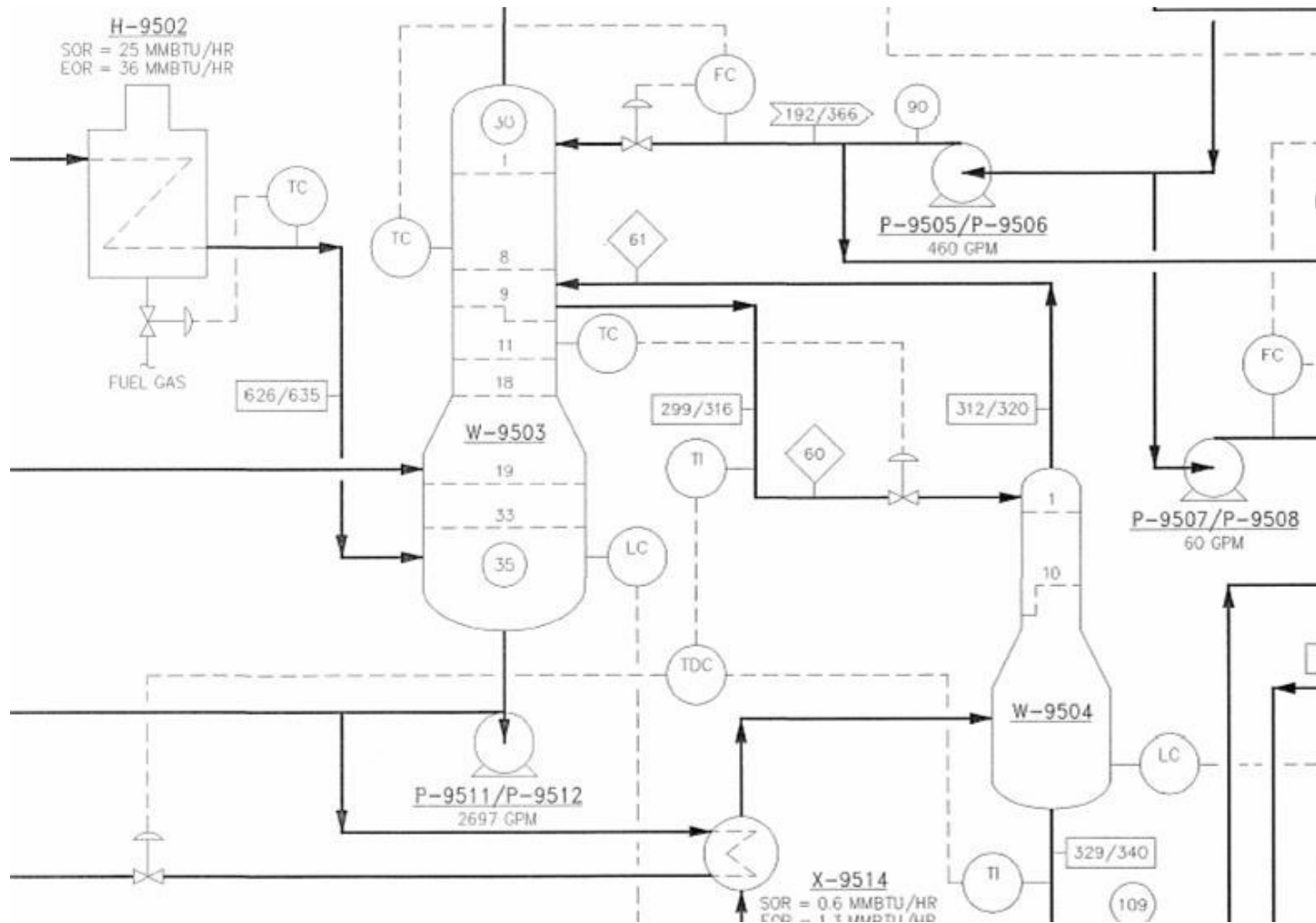

# Process Flow Diagram

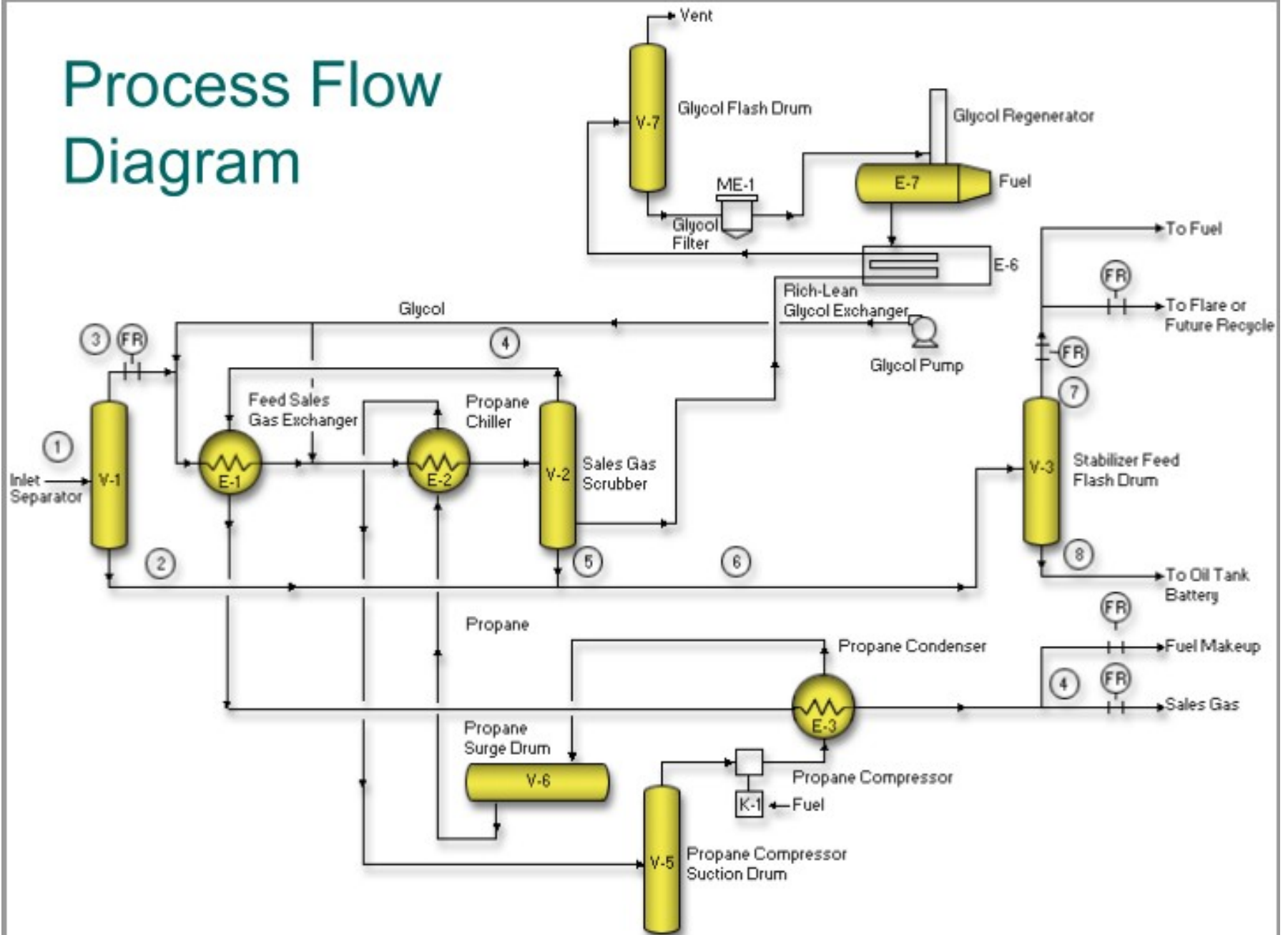

# A P&ID is:

---

- ↳ Language of Symbols
- ↳ Schematic of Process
- ↳ Displays Relative Orientation/Configuration/Function
- ↳ Communication Tool
- ↳ Graphical Table of Contents

# A P&ID is not:

---

- ⊣ Piping Isometric
- ⊣ Equipment Fabrication Diagram
- ⊣ Scale Drawing
- ⊣ Control Logic Diagram
- ⊣ Something to Convey Process Information



# P & ID

---

## CONTAINS DETAILED INFORMATION

- Process & Utility Streams
- All Process Equipment
- Complete Instrumentation
- Analog & Digital Control



# P&ID LEGEND

---

- └─H Symbols and Tagging Information
- └─H Instrument Signal Types
- └─H Relay Functions
- └─H Logic Symbols
- └─H Valve Body and Actuator Symbols
- └─H Abbreviations
- └─H Miscellaneous Symbols and Information

# P & ID LEGEND

---

## Instrument Symbols Design Basis

- └─ ISA S5.1 Instrumentation Symbols and Identification
  - └─ Defines:
    - └─ Instrument Symbols
    - └─ Tagging Conventions
    - └─ Loop Identification
  - └─ Provides Examples
- └─ ISA S5.3 DCS Symbols
- └─ Client Requirements



## Instrument Symbols Design Basis

---

The Instrumentation, Systems, and Automation Society (ISA) is one of the leading process control trade and standards organizations. The ISA has developed a set of symbols for use in engineering drawings and designs of control loops (ISA S5.1 instrumentation symbol specification).



# P&ID LEGEND

---

→ How to read P&ID





# BALLOONS

---

The balloon or bubble symbol - this represents an instrumentation and control device.

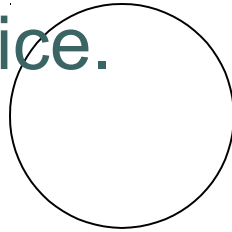

The size is **5/16"** or **10 mm in diameter**

General guideline: **the text inside must be readable**



# According to ISA:

---

**Local:** *The location of an instrument that is neither in nor on a panel or console, nor is it mounted in a control room. Local instruments are commonly in the vicinity of a primary element or a final control element. The word "field" is often used synonymously with local.*

**Local panel:** *A panel that is not a central or main panel. Local panels are commonly in the vicinity of plant subsystems or sub-areas. The term "local panel instrument" should not be confused with "local instrument."*

**Panel-mounted:** *A term applied to an instrument that is mounted on a panel or console and is accessible for an operator's normal use. A function that is normally accessible to an operator in a shared-display system is the equivalent of a discrete panel-mounted device.*

# BALLOONS

Types of balloon symbols:

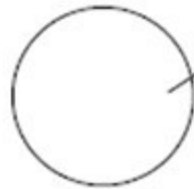

**no line** inside  
(field or locally mounted)

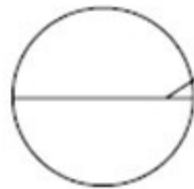

with **solid line** inside  
(front panel mounted)

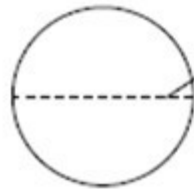

with **broken line** inside  
(inside panel mounted)

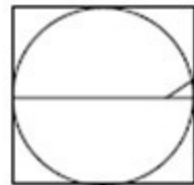

**inscribed** by a square  
(DCS control system)

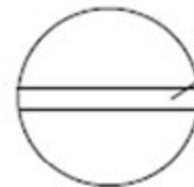

with **double lines** inside  
(local panel mounted)

# BALLOONS

In a P&ID, a circle represents individual measurement instruments, such as transmitters, sensors, and detectors

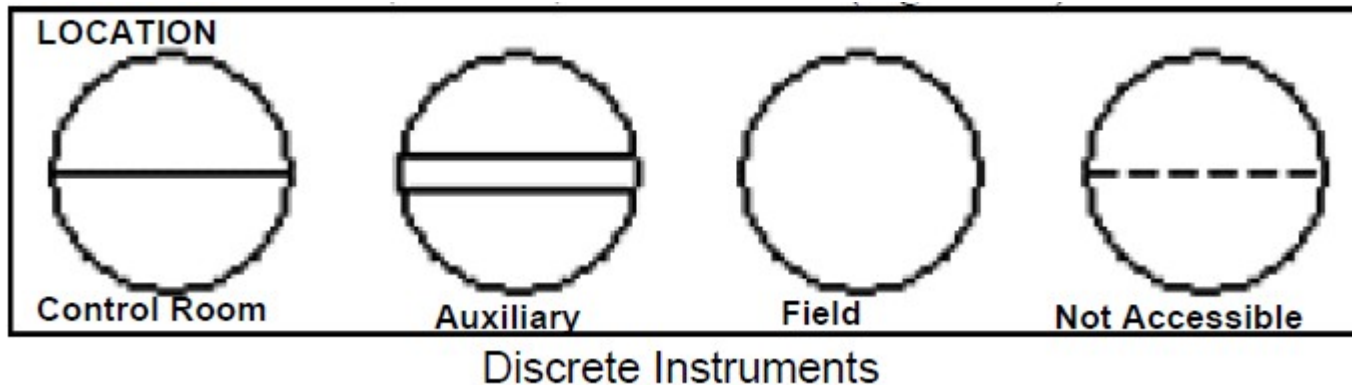

- Single horizontal line indicates that the instrument or function is located in a primary location (e.g., a control room).
- Double horizontal line indicates that the function is in an auxiliary location
- Absence of the line indicates that the function is field mounted
- Dotted line indicates that the function or instrument is inaccessible

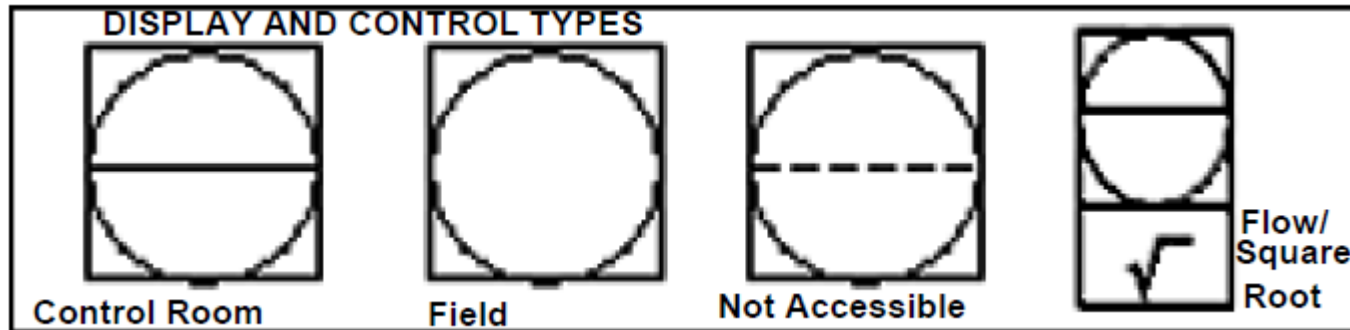

A square with a circle inside represents instruments that both display measurement readings and perform some control function

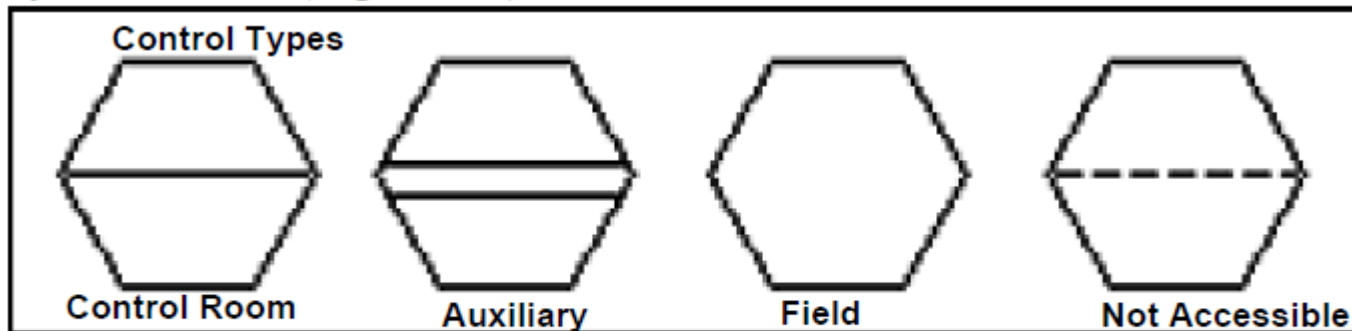

Computer Functions (Controllers)

A hexagon represents **computer functions**, such as those carried out by a controller

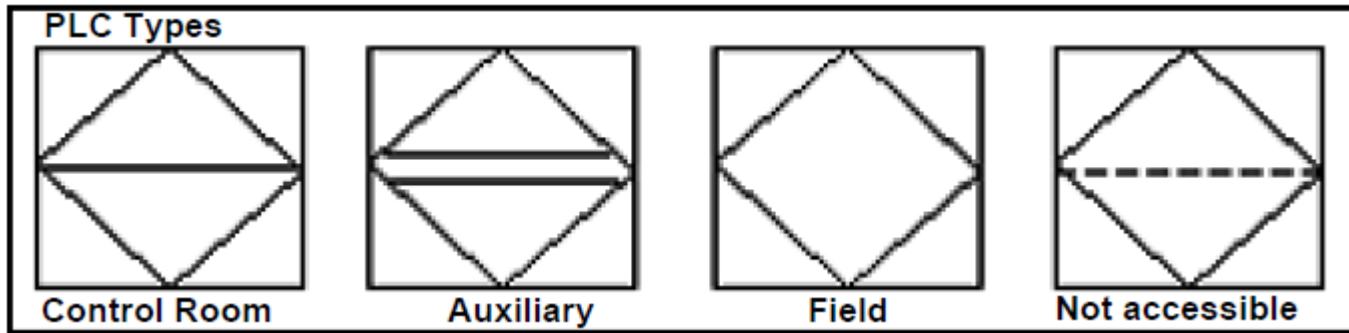



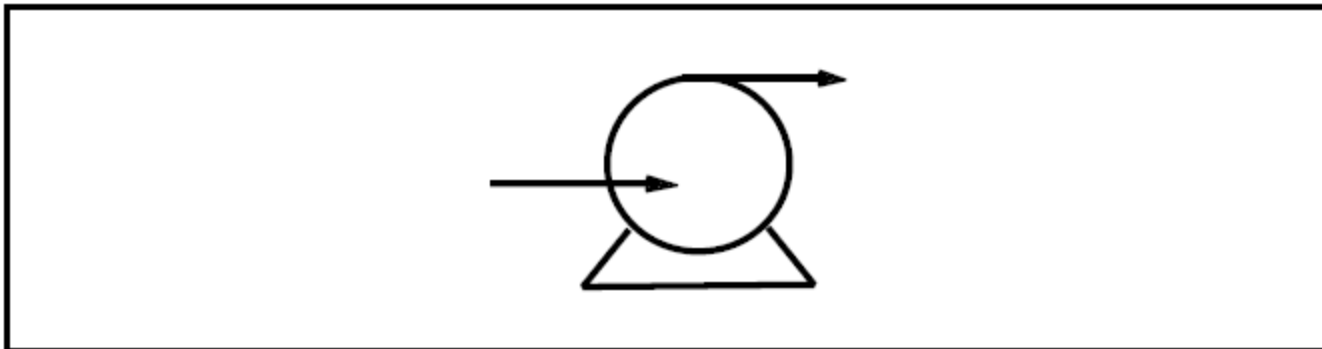

A square with a diamond inside represents

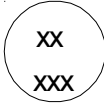
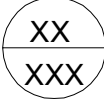
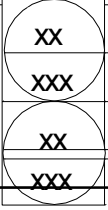
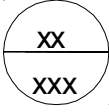
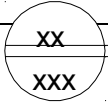
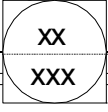
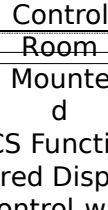
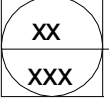
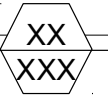

Directional arrows showing the flow direction represent a ***pump***.

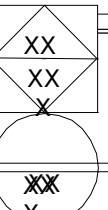
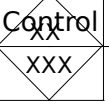
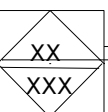
# P&ID LEGEND

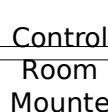
<p><b>INSTRUMENT BALOONS</b></p>	 <p>Local Mounted Discrete Instrument</p>	 <p>Control Room Mounted Discrete Instrument</p>	 <p>Control Room Mounted DCS Function-Shared Display / Control with Auxilliary Operator Interphase Device</p>
 <p>Control Room Mounted Discrete Instrument Operator Inaccessible or Back of Panel</p>	 <p>Local Panel Mounted Discrete Instrument</p>	 <p>Control Room Mounted Instrument With Shared Control</p>	 <p>Control Room Mounted DCS Function-Shared Display / Control with Auxilliary Operator Interphase Device</p>
 <p>Control Room Mounted Instrument with Shared Display And Shared Control</p>	 <p>Main Control Room Mounted Computer Function</p>	 <p>Secondary Mounted Control</p>	 <p>Control Room Mounted DCS Logic Function-Shared Display / Control with Auxilliary Operator</p>
 <p>Control Room Mounted Programable Logic Control</p>	 <p>Local Panel Mounted Programmable Logic Control</p>	 <p>Control Room Mounted Distributed Logic Control</p>	 <p>Control Room Mounted DCS Logic Function-Shared Display / Control with Auxilliary Operator</p>

# The Tag Symbol

---

This represents a unique name given as an identification.

Example: PIC-069

Where it is placed:

- inside the balloon symbol

Example:

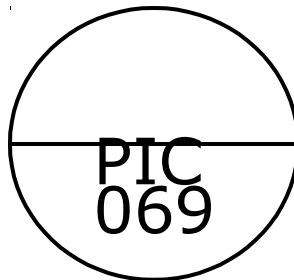

# P & ID LEGEND - INSTRUMENT TAGGING

## TYPICAL TAGGING CONVENTION

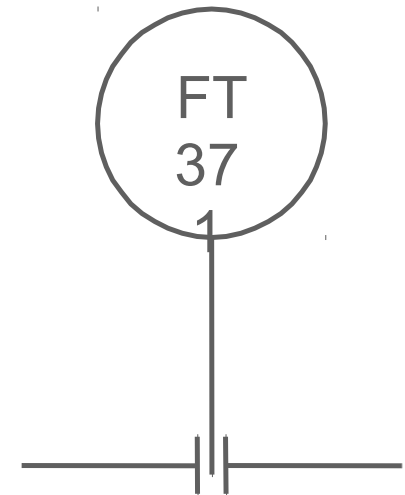
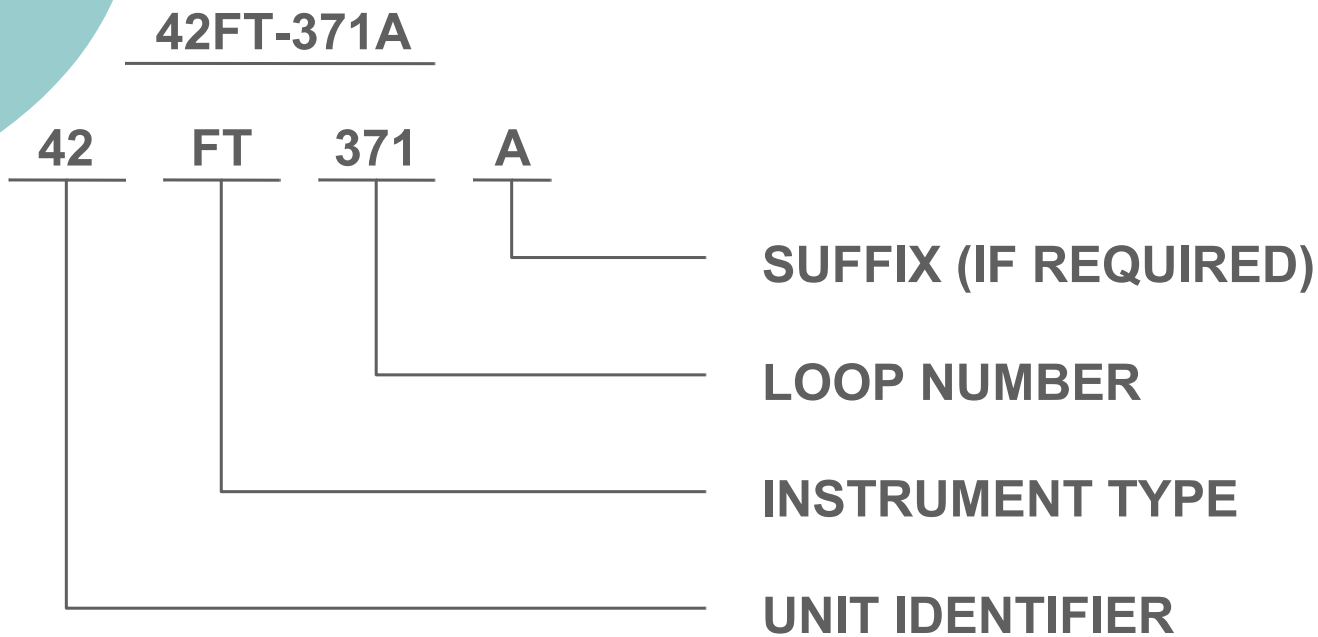



## Example:

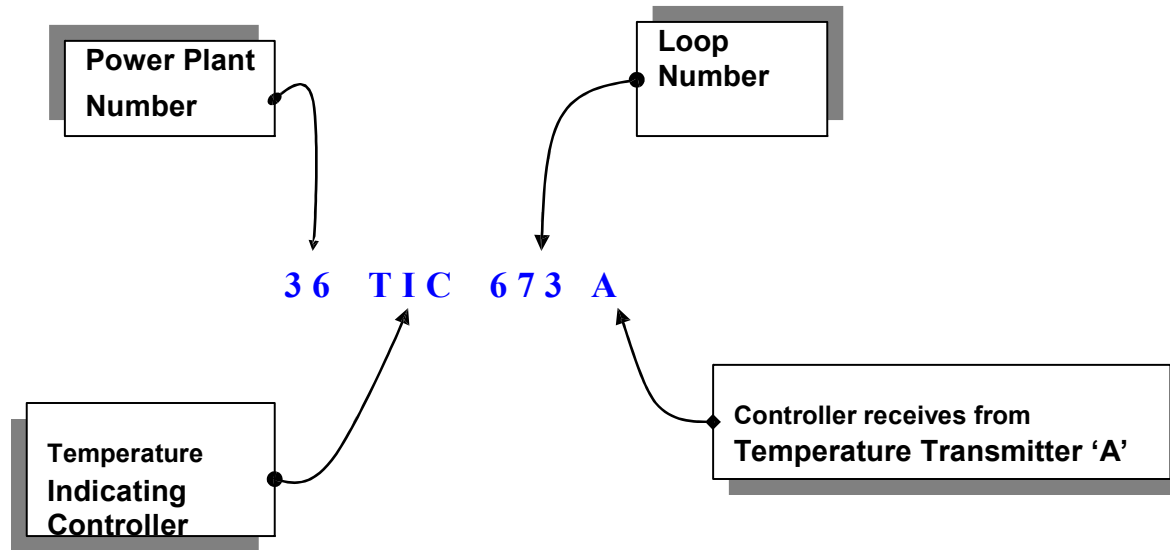

This describes a **Temperature Indicating Controller**, belonging to **No. 673** located at **Plant No. 36** **Loop** (where this controller receives signal from two separate **Temperature Transmitters**). The suffix **A** if used, One of them would be tagged as **36 TIC 673A** and the other would be **36 TIC 673B**.

# P & ID LEGEND - INSTRUMENT TAGGING

**Instrument identification system, generally the following**

**e :**

1. Tag number to define process function loop number and plant section, process
2. Symbol to identify pneumatic, electrical, capillary, hydraulic, or radioactivity process, control system
3. signals to represent primary and Final Control Symbol that govern level, pressure, temperature and other process variables, i.e. flow, etc.

Following is a table showing the functional meanings of identification letters as designated by the Instrument Society of America ( ISA Recommended Practice RP 5.1 )

## Identification Letters

	FIRST-LETTER		SUCCEEDING-LETTERS		
	MEASURED OR INITIATING VARIABLE	MODIFIER	REAOUT OR PASSIVE FUNCTION	OUTPUT FUNCTION	MODIFIER
<b>A</b>	Analysis		Alarm		
<b>B</b>	Burner, Combustion		User's Choice	User's Choice	User's Choice
<b>C</b>	User's Choice				
<b>D</b>	User's Choice	Differential		Control	
<b>E</b>	Voltage				
<b>F</b>	Flow Rate	Ratio (Fraction)	Sensor (Primary Element)		
<b>G</b>	User's Choice		Glass, Viewing Device		
<b>H</b>	Hand				High
<b>I</b>	Current (Electrical)		Indicate		
<b>J</b>	Power	Scan			
<b>K</b>	Time, Time Schedule	Time Rate of Change		Control Station	
<b>L</b>	Level		Light		Low
<b>M</b>	User's Choice	Momentary			Middle, Intermediate
<b>N</b>	User's Choice		User's Choice		User's Choice
<b>O</b>	User's Choice		Orifice, Restriction		
<b>P</b>	Pressure, Vacuum		Point (Test) Connection		
<b>Q</b>	Quantity	Integrate, Totalize			
<b>R</b>	Radiation		Record		
<b>S</b>	Speed, Frequency	Safety		Switch	
<b>T</b>	Temperature			Transmit	
<b>U</b>	Multivariable		Multifunction	Multifunction	Multifunction
<b>V</b>	Vibration, Mechanical Analysis			Valve, Damper, Louver	
<b>W</b>	Weight, Force		Well		
<b>X</b>	Unclassified	X Axis	Unclassified	Unclassified	Unclassified
<b>Y</b>	Event, State or Presence	Y Axis		Relay, Compute, Convert	
<b>Z</b>	Position, Dimension	Z Axis			

# P & ID LEGEND – Instrument Identification Letters

# P & ID LEGEND – Instrument Identification Letters

## Identification Letters

	FIRST-LETTER		SUCCEEDING-LETTERS		
	MEASURED OR INITIATING VARIABLE	MODIFIER	REAOUT OR PASSIVE FUNCTION	OUTPUT FUNCTION	MODIFIER
<b>A</b>	Analysis		Alarm		
<b>B</b>	Burner, Combustion		User's Choice	User's Choice	User's Choice
<b>C</b>	User's Choice				
<b>D</b>	User's Choice	Differential		Control	
<b>E</b>	Voltage				Divert
<b>F</b>	Flow Rate	Ratio (Fraction)	Sensor (Primary Element)		
<b>G</b>	User's Choice		Glass, Viewing Device		
<b>H</b>	Hand				High
<b>I</b>	Current (Electrical)		Indicate		
<b>J</b>	Power	Scan			
<b>K</b>	Time, Time Schedule	Time Rate of Change		Control Station	
<b>L</b>	Level		Light		Low
<b>M</b>	User's Choice	Momentary			Middle, Intermediate
<b>N</b>	User's Choice		User's Choice		User's Choice

B – Flame

C – Typically Conductivity – Electrical

D – Typically Density or Specific Gravity

G – Gauging (Dimensional)

# P & ID LEGEND – Instrument Identification Letters (continuation...)

## Identification Letters

	FIRST-LETTER		SUCCEEDING-LETTERS		
	MEASURED OR INITIATING VARIABLE	MODIFIER	REAOUT OR PASSIVE FUNCTION	OUTPUT FUNCTION	MODIFIER
<b>P</b>	Pressure, Vacuum		Point (Test) Connection		
<b>Q</b>	Quantity	Integrate, Totalize			
<b>R</b>	Radiation		Record		
<b>S</b>	Speed, Frequency	Safety		Switch	
<b>T</b>	Temperature			Transmit	
<b>U</b>	Multivariable		Multifunction	Multifunction	Multifunction
<b>V</b>	Vibration, Mechanical Analysis			Valve, Damper, Louver	
<b>W</b>	Weight, Force		Well		
<b>X</b>	Unclassified	X Axis	Unclassified	Unclassified	Unclassified
<b>Y</b>	Event, State or Presence	Y Axis		Relay, Compute, Convert	
<b>Z</b>	Position, Dimension	Z Axis			

# P & ID LEGEND - INSTRUMENT TAGGING

---

## ISA-S5.1 INSTRUMENT IDENTIFICATION

### FIRST LETTER

≡ F	FLOW
≡ L	LEVEL
≡ P	PRESSURE
≡ T	TEMPERATURE
≡ H	HAND
≡ S	SPEED
≡ V	VIBRATION

### SUCCEEDING LETTERS

≡ A	ALARM
≡ E	ELEMENT
≡ I	INDICATE
≡ S	SWITCH
≡ T	TRANSMITTER
≡ V	VALVE

# First Letter Code

---

In general, the ***process*** that is to be monitored by the instrument is indicated by the ***first letter*** of the coding, for example:

F = Flow

L = Level

P = Pressure

T = Temperature

# Second Letter Code

---

The second letter in the coding indicates the ***function*** of the instrument, for example:

FI = Flow **I**ndicator

FC = Flow **C**ontroller

LA = Level **A**larm

LR = Level **R**ecorder

PT = Pressure **T**ransmitter

TE = Temperature  
**E**lement



# Optional Third Letter Code

---

In some cases, when the instrument is used for ***two purposes*** or when the function of the instrument has to be more clearly specified, a third letter is used,

for example:

FIC = Flow **I**ndicating **C**ontroller

LAH = Level **A**larm **H**igh

LAL = Level **A**larm **L**ow

Example:

Succeeding-Letter

### Instrument Symbols

*A	Alarm	*S	Switch
*AH	Alarm High	*SH	Switch High
*AL	Alarm Low	*SL	Switch Low
*AHL	Alarm High Low	*V	Valve
*C	Controller	*SV	Solenoid Valve
*CV	Control Valve	*T	Transmitter
*K	<b>Station</b>	*Q	Totalizer
*E	Element	*Y	Relay
*I	Indicator		
*IC	Indicating Controller		
*R	Recorder	*G	Glass
*RC	Recording Controller		



# LOOP

---

a combination of two or more instruments or control function arranged so that signals pass from one to another for the purpose of measurement and/or control of a process variable.

# TYPICAL LOOP: Actual

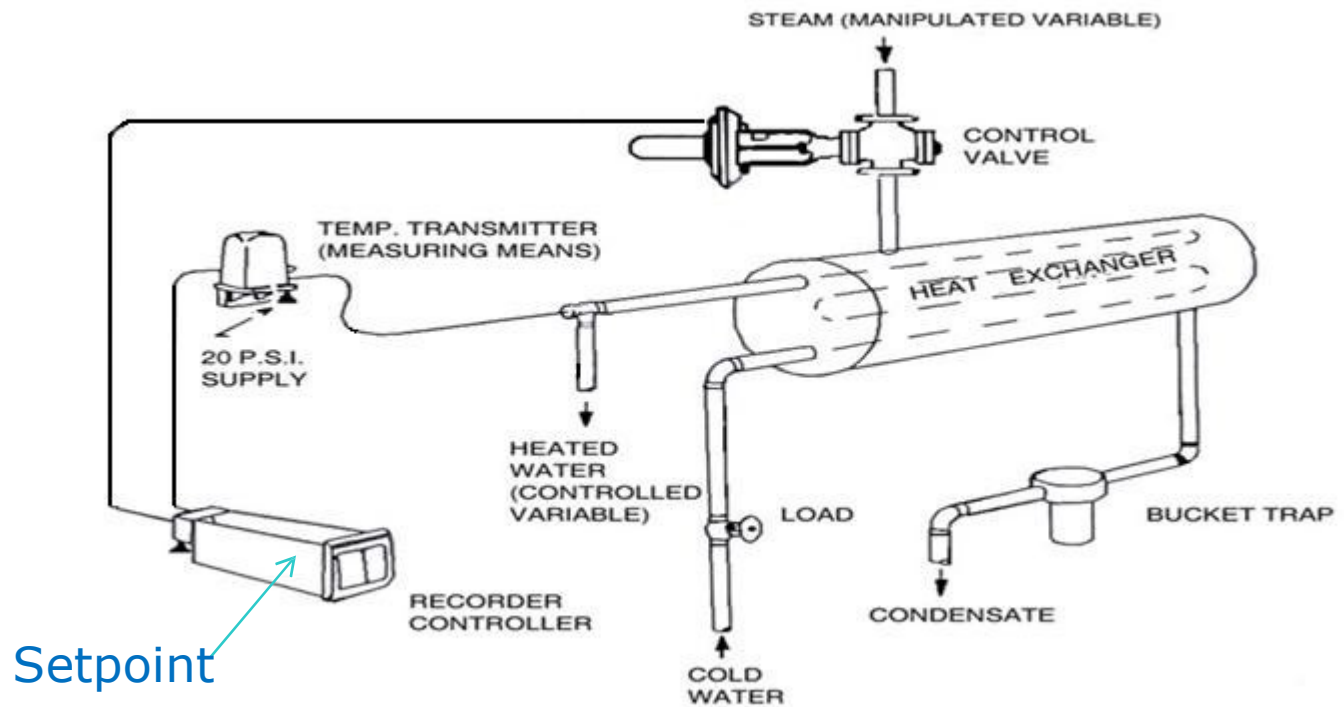

# TYPICAL LOOP: P & ID

## Typical Flow Loop with Separate I/P

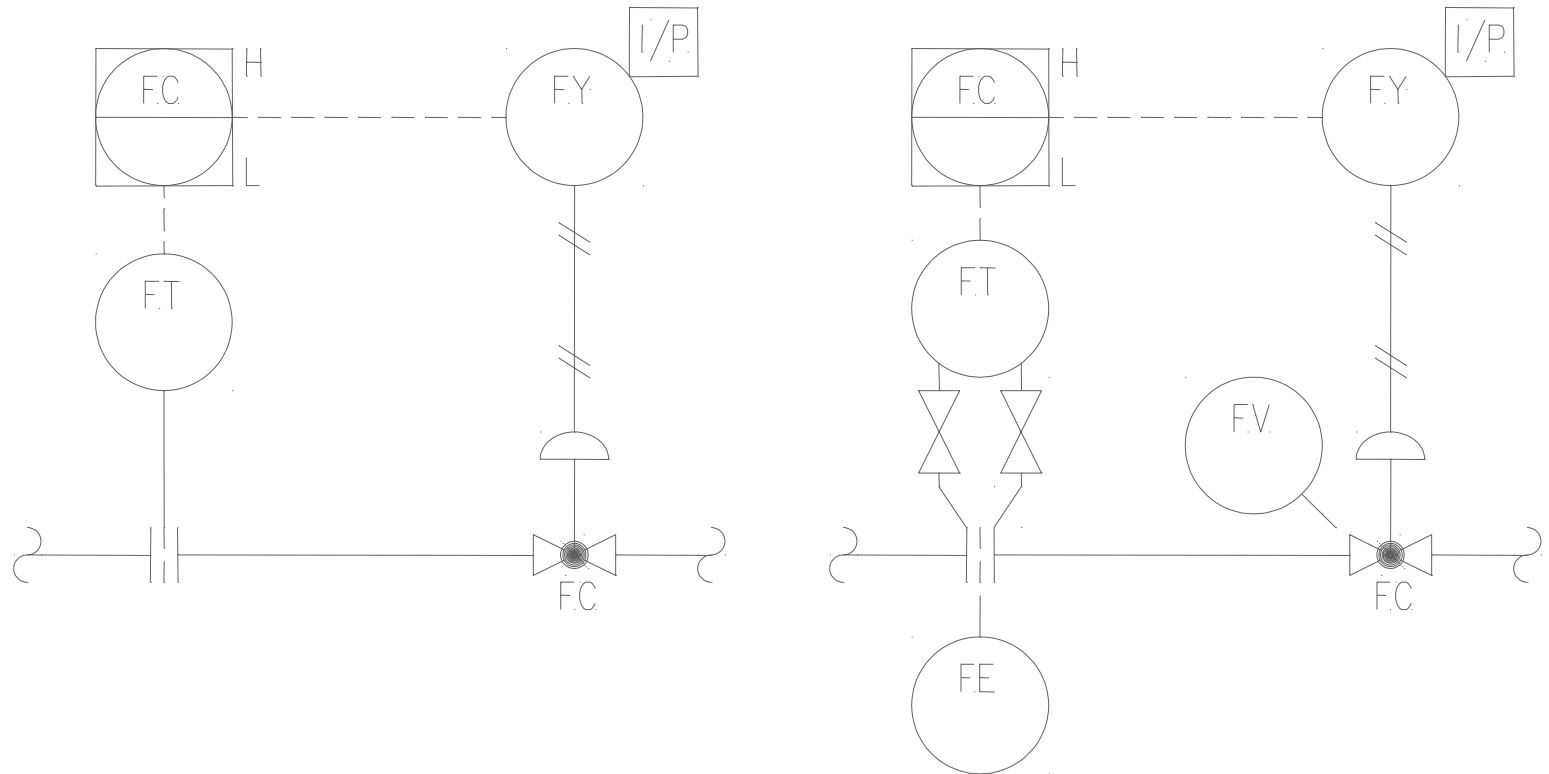

Shown on P&ID

Implied

# Pressure Control Loop

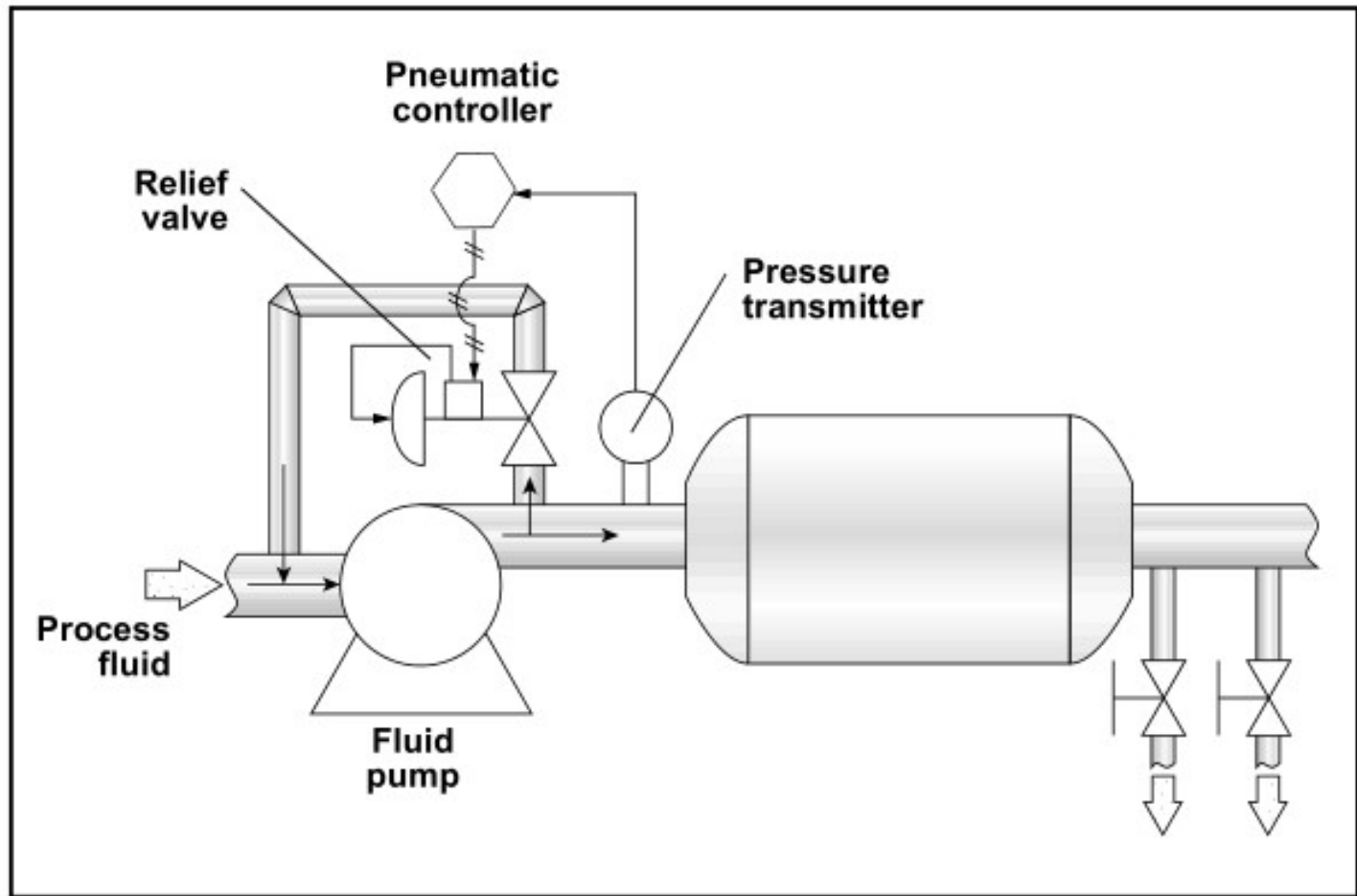

A Pressure Loop

# Flow Control Loop

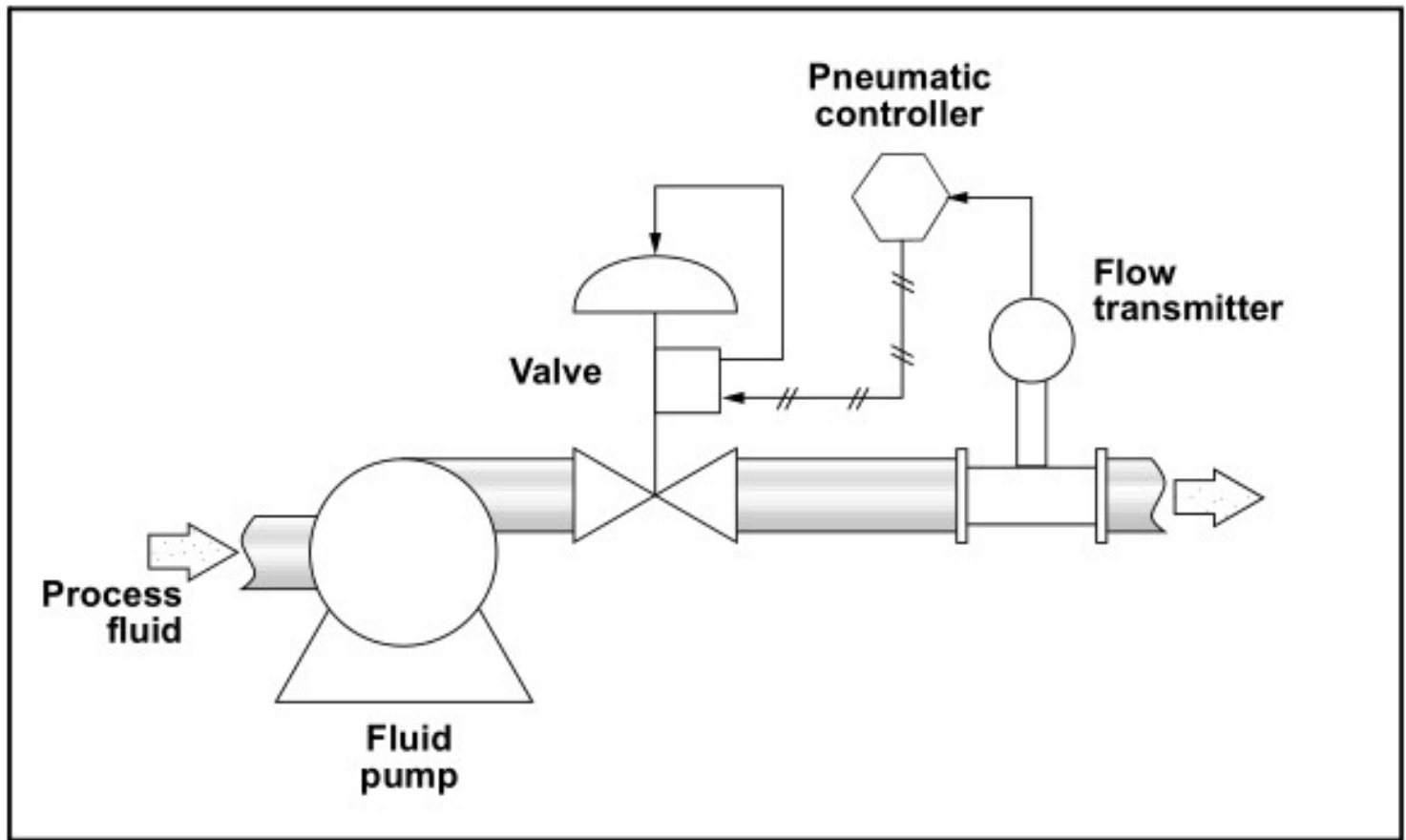

A Flow Loop

# Level Control Loop

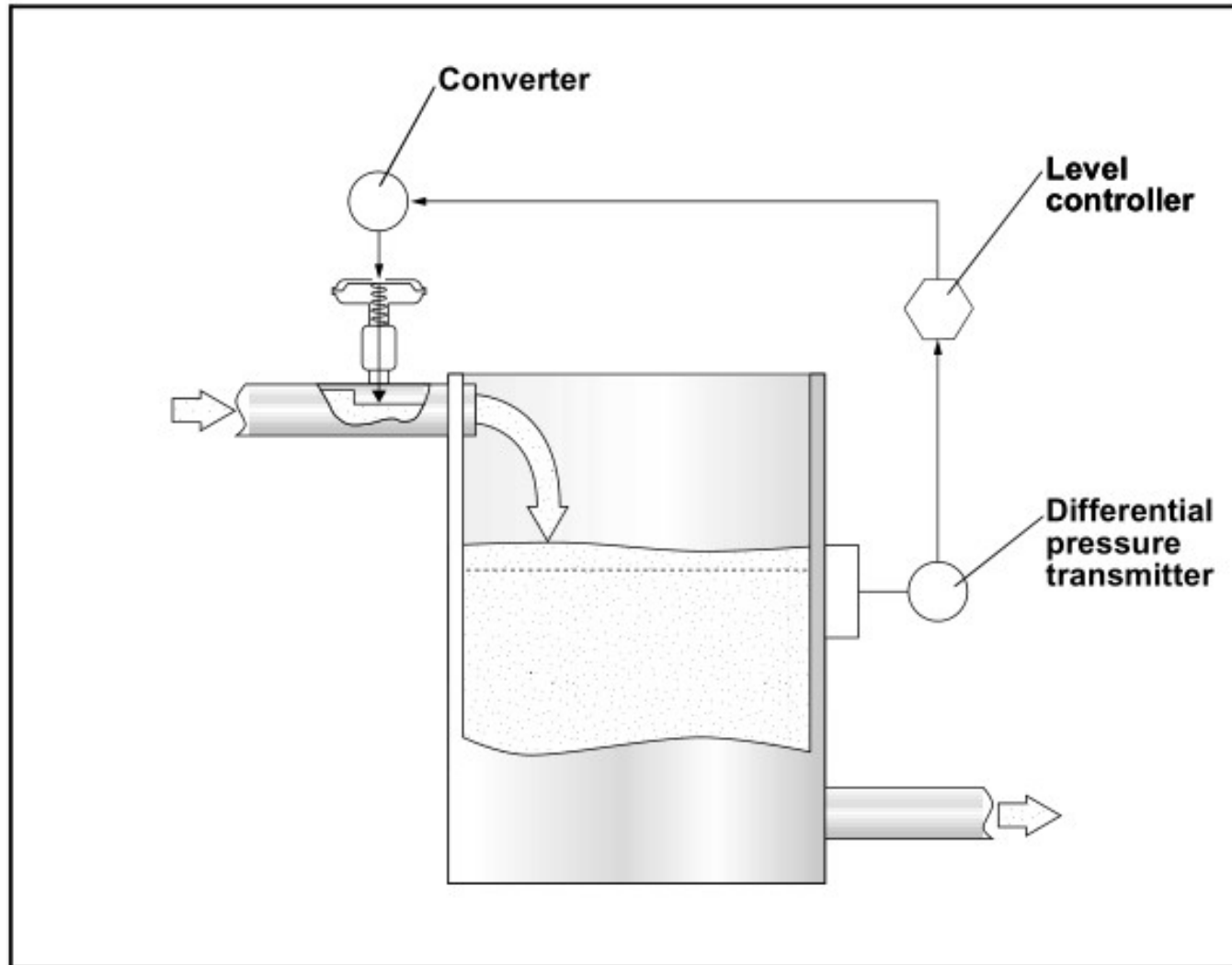



# Temperature Control Loop

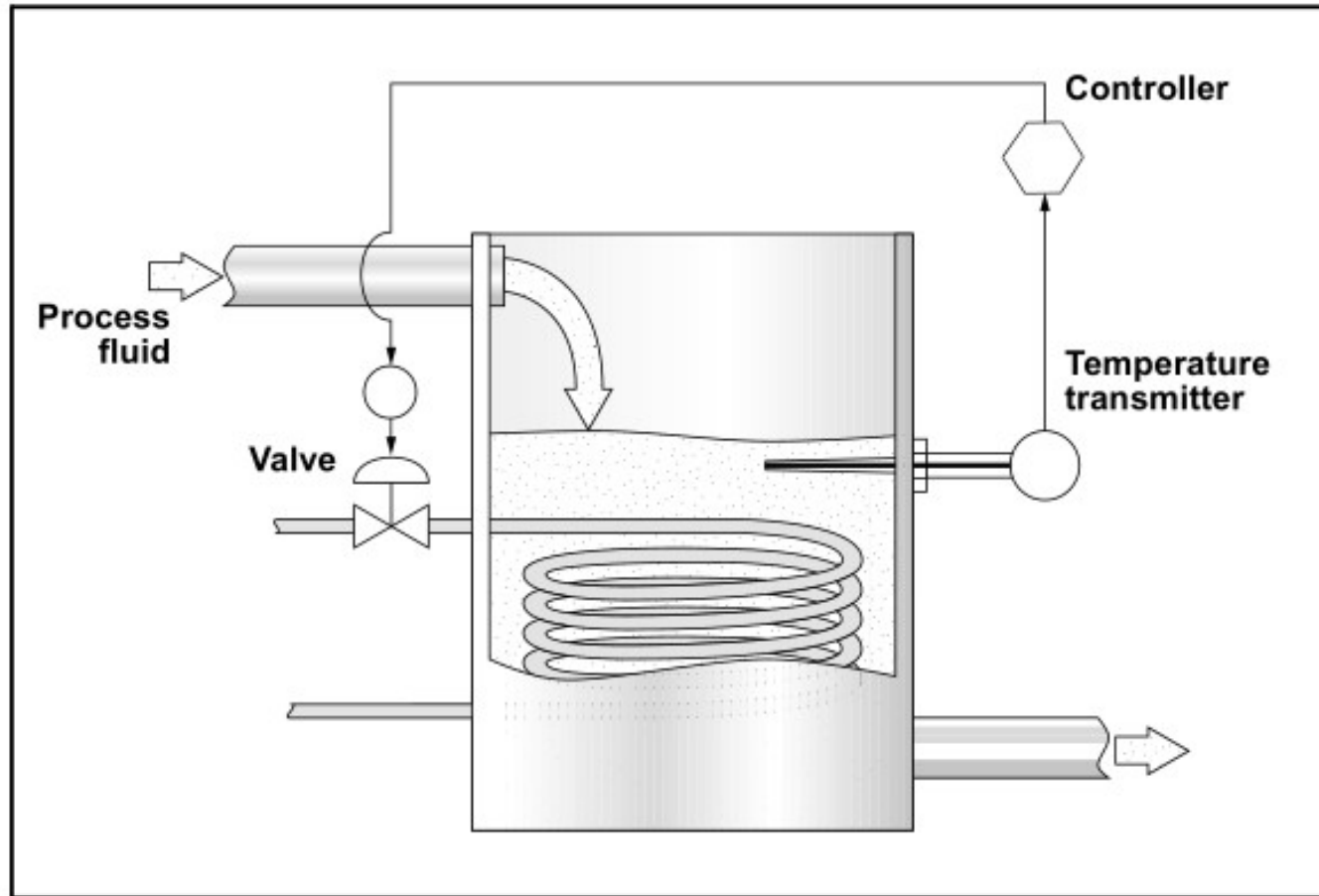

A Temperature Loop

# Field or Locally Mounted Symbol

---

A circle with ***lettered code only*** represents a ***field*** or ***locally mounted*** instrument.

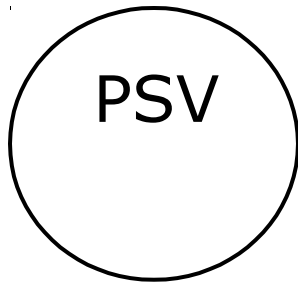

# Field or Locally Mounted Symbol

---

A circle with ***lettered code only*** represents a ***field*** or ***locally mounted*** instrument.

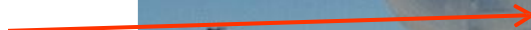
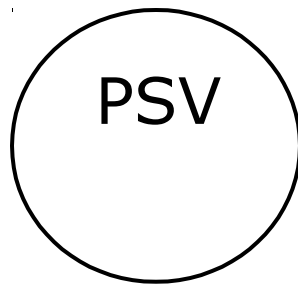

# Field or Locally Mounted Symbol

---

PIT



PT



# Field or Locally Mounted Symbol

---

PIT



PT



# Field or Locally Mounted Symbol

PIT





# Field or Locally Mounted Symbol

PIT



# Field or Locally Mounted Symbol

---

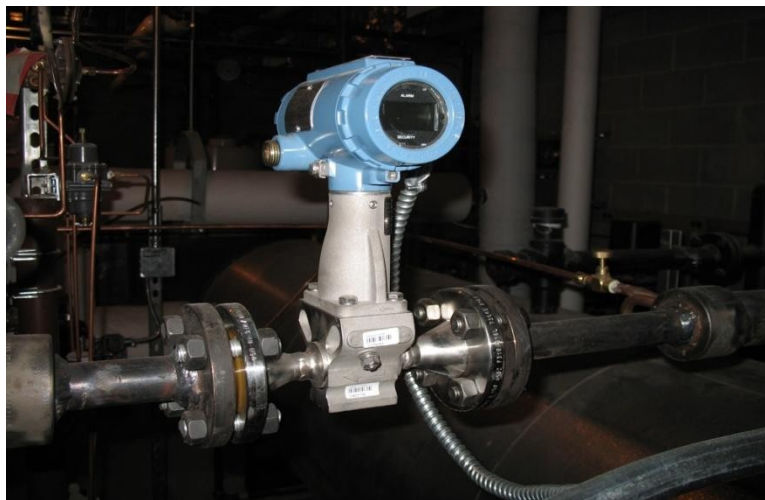
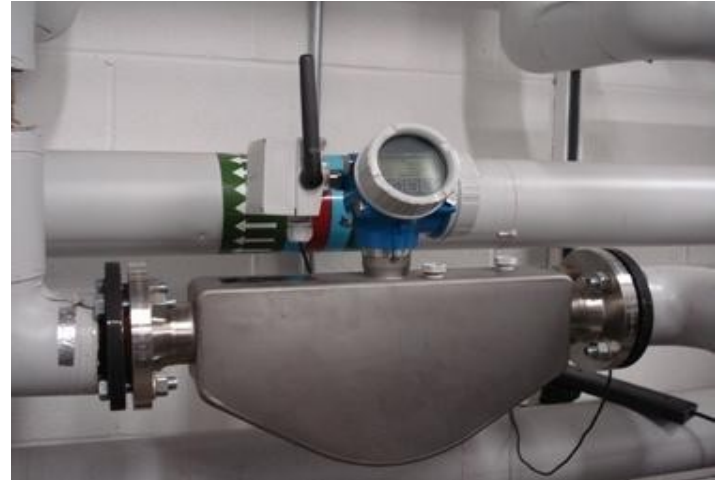
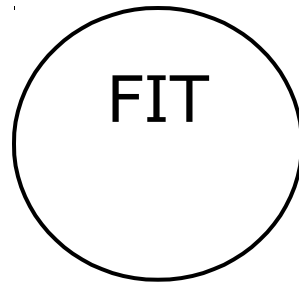



# Field or Locally Mounted Symbol

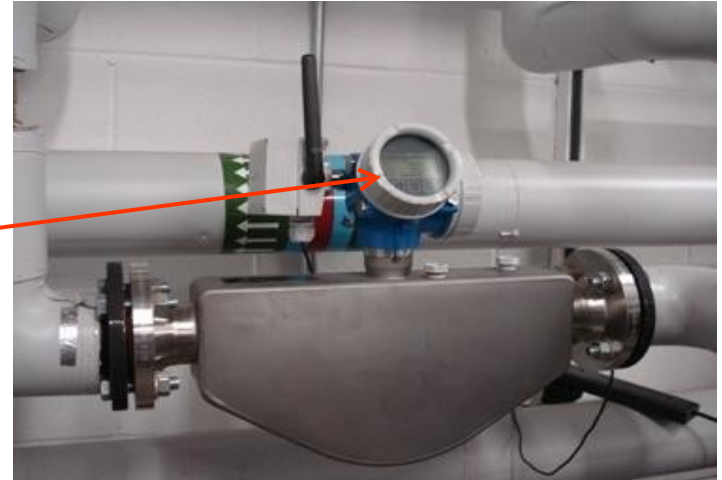
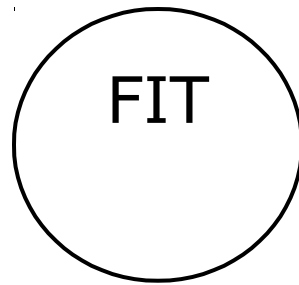

# Field or Locally Mounted Symbol

FIT

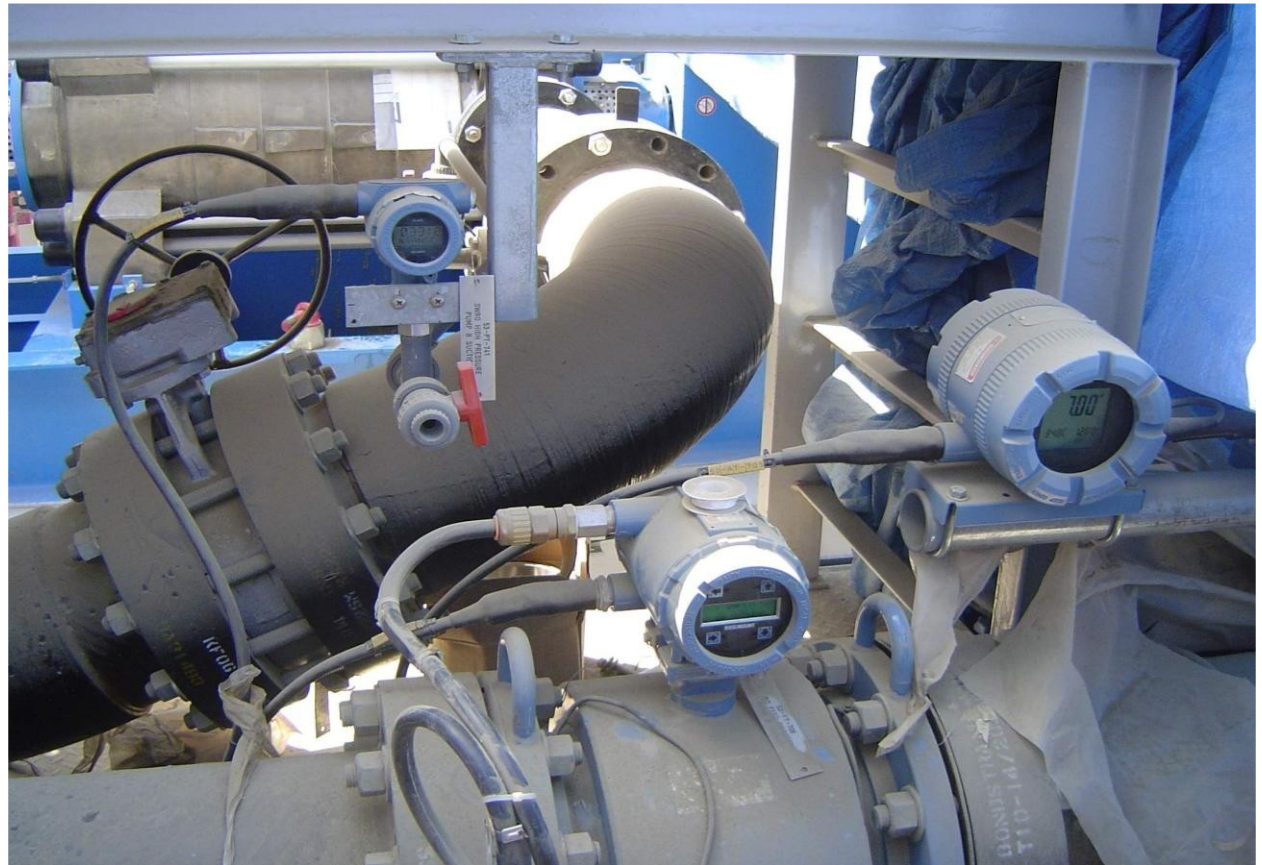

# Field or Locally Mounted Symbol

FIT

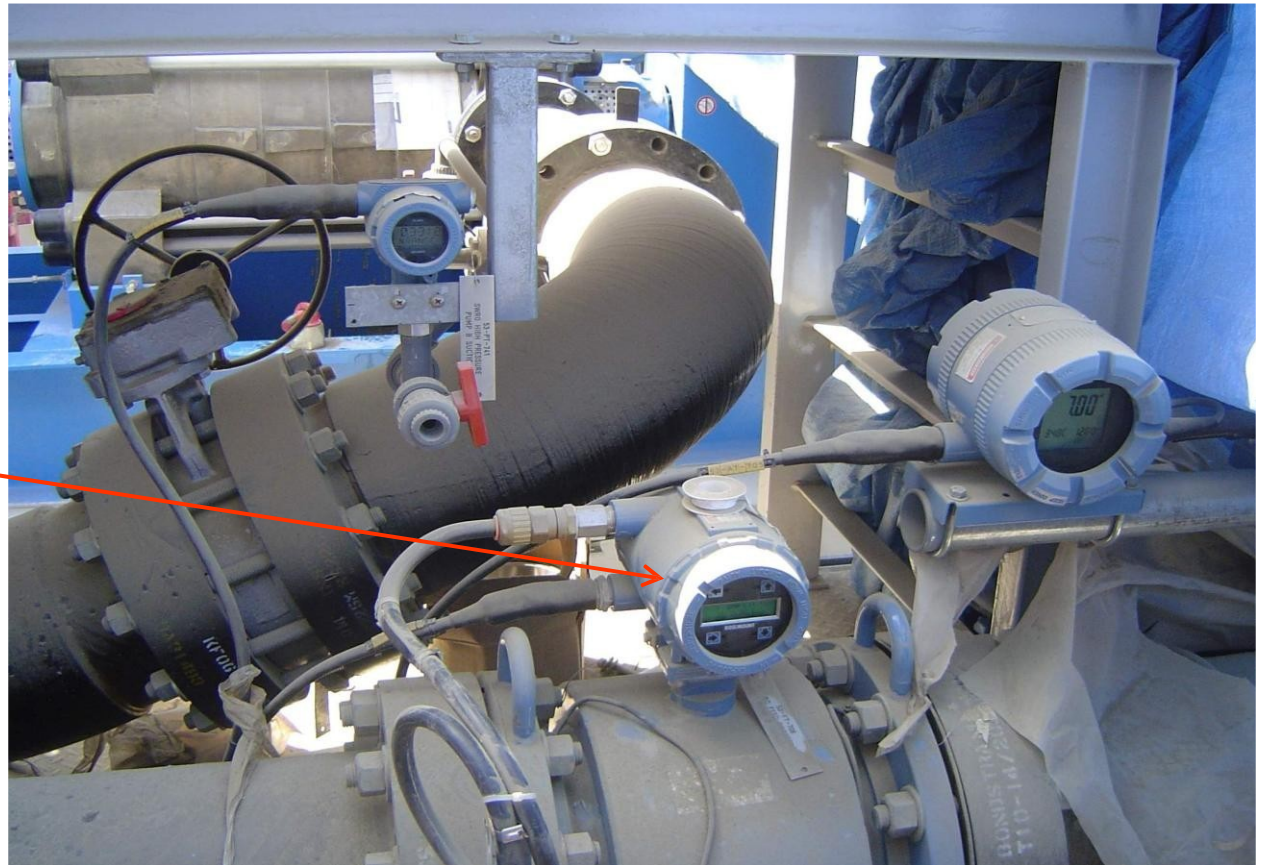

# Field or Locally Mounted Symbol

---

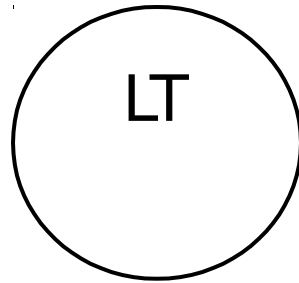

# Field or Locally Mounted Symbol

---

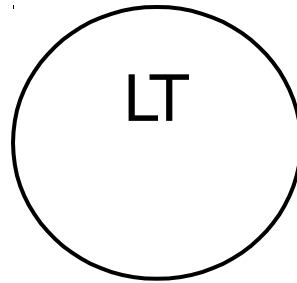



# Field or Locally Mounted Symbol

LIT



# Field or Locally Mounted Symbol

LIT



# Field or Locally Mounted Symbol

---



Instrument Stanchion (Wall Mounted)



# Field or Locally Mounted Symbol

---



Instrument Stanchion

# Field or Locally Mounted Symbol

---



Transmitters

# Field or Locally Mounted Symbol

---



Control Valve



# Field or Locally Mounted Symbol

---



Relief Valve

# Local Panel Mounted

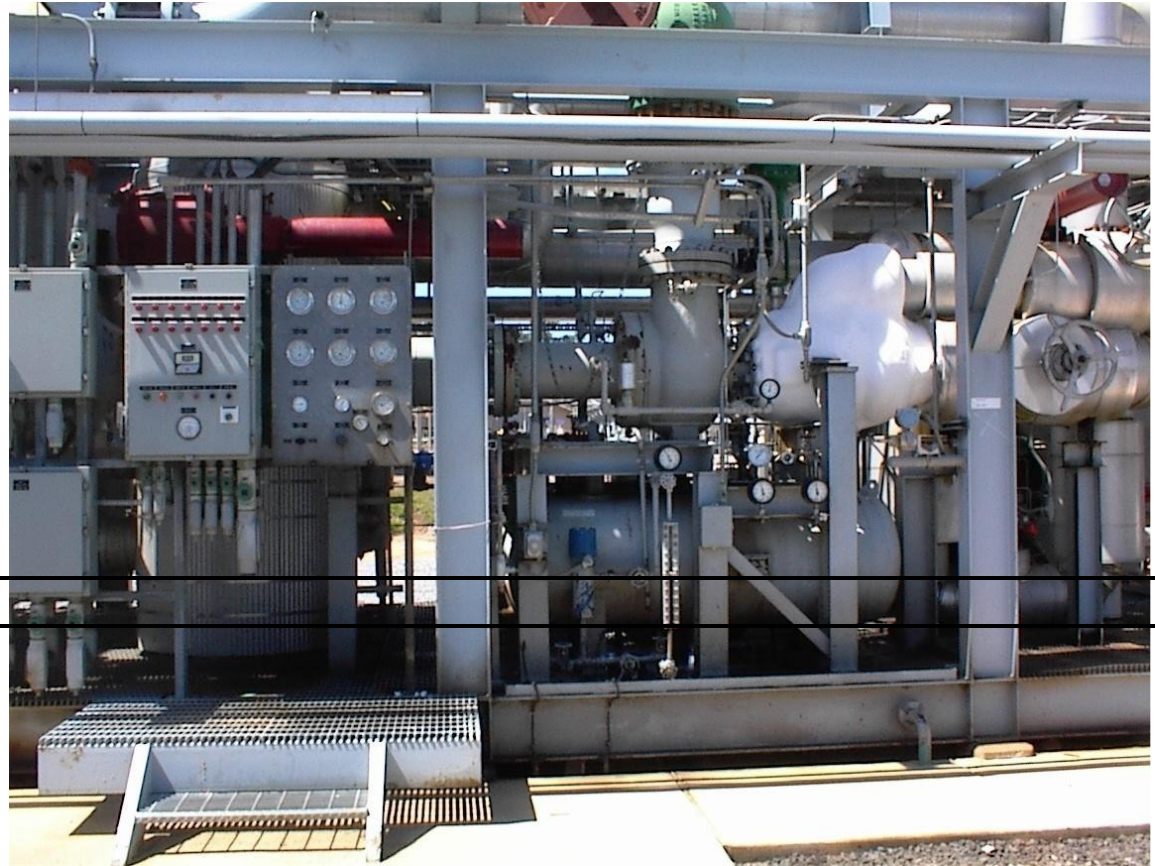
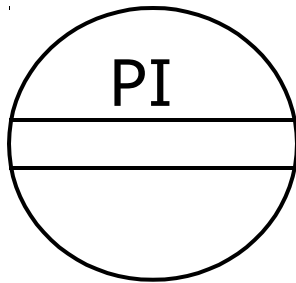
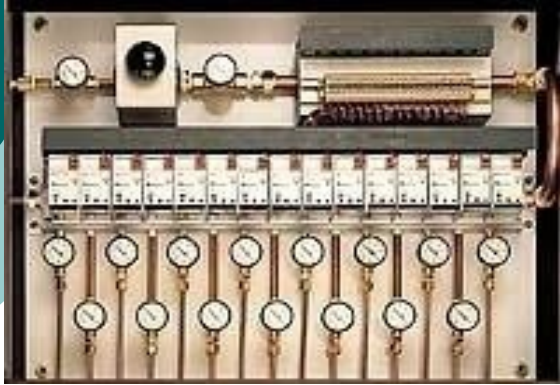



# Local Panel Mounted

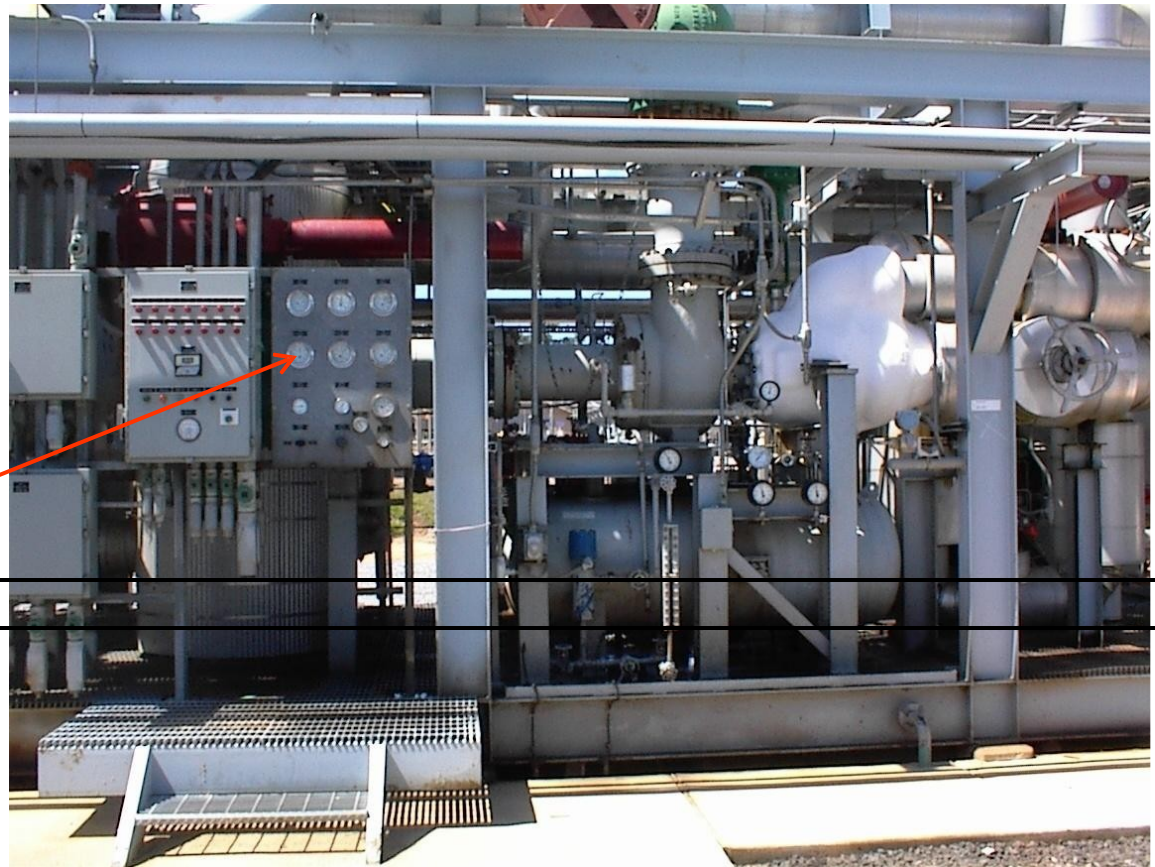
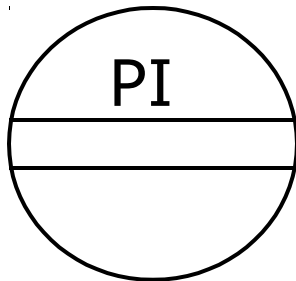
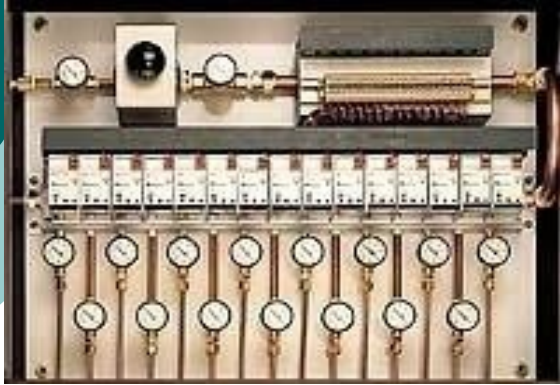

# Local Panel Mounted

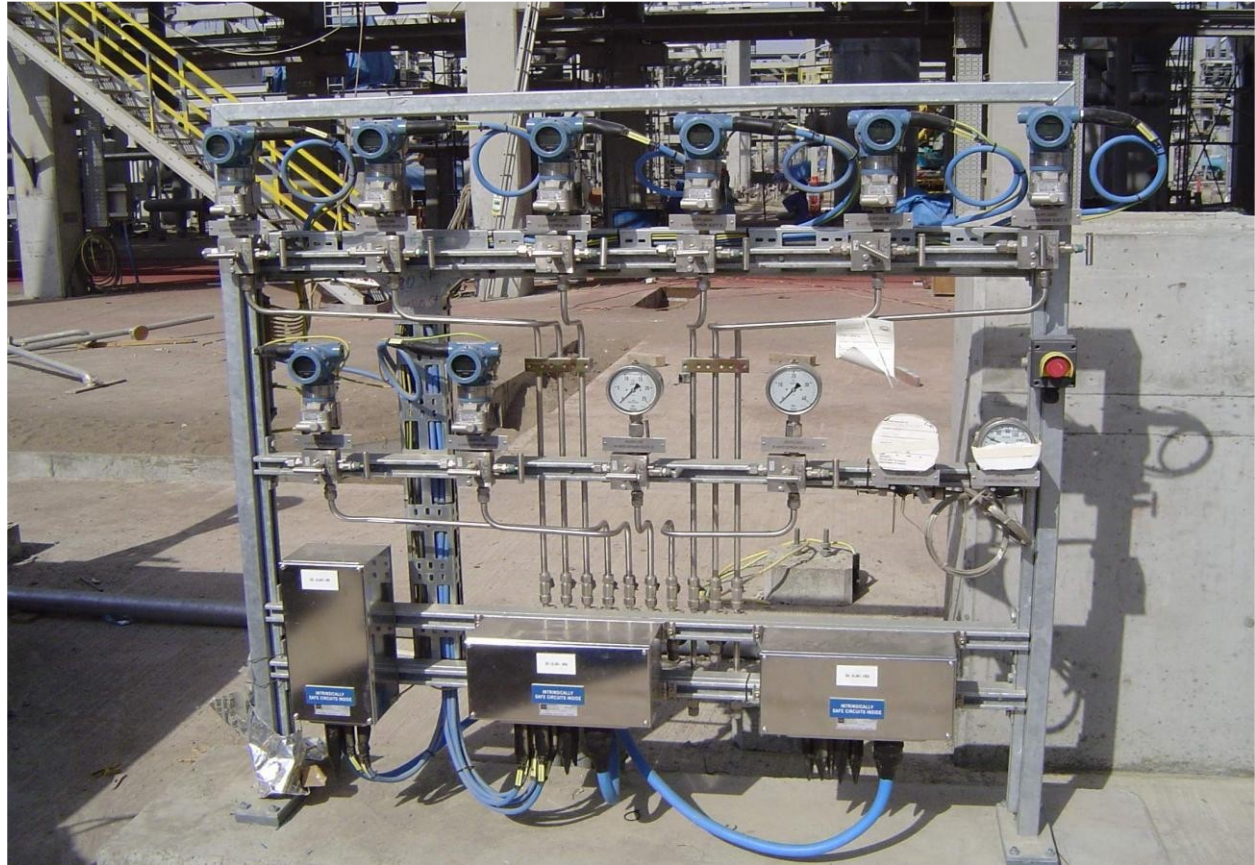

Local Gauge Rack



# Local Panel Mounted

---



Local Panel



# Local Panel Mounted

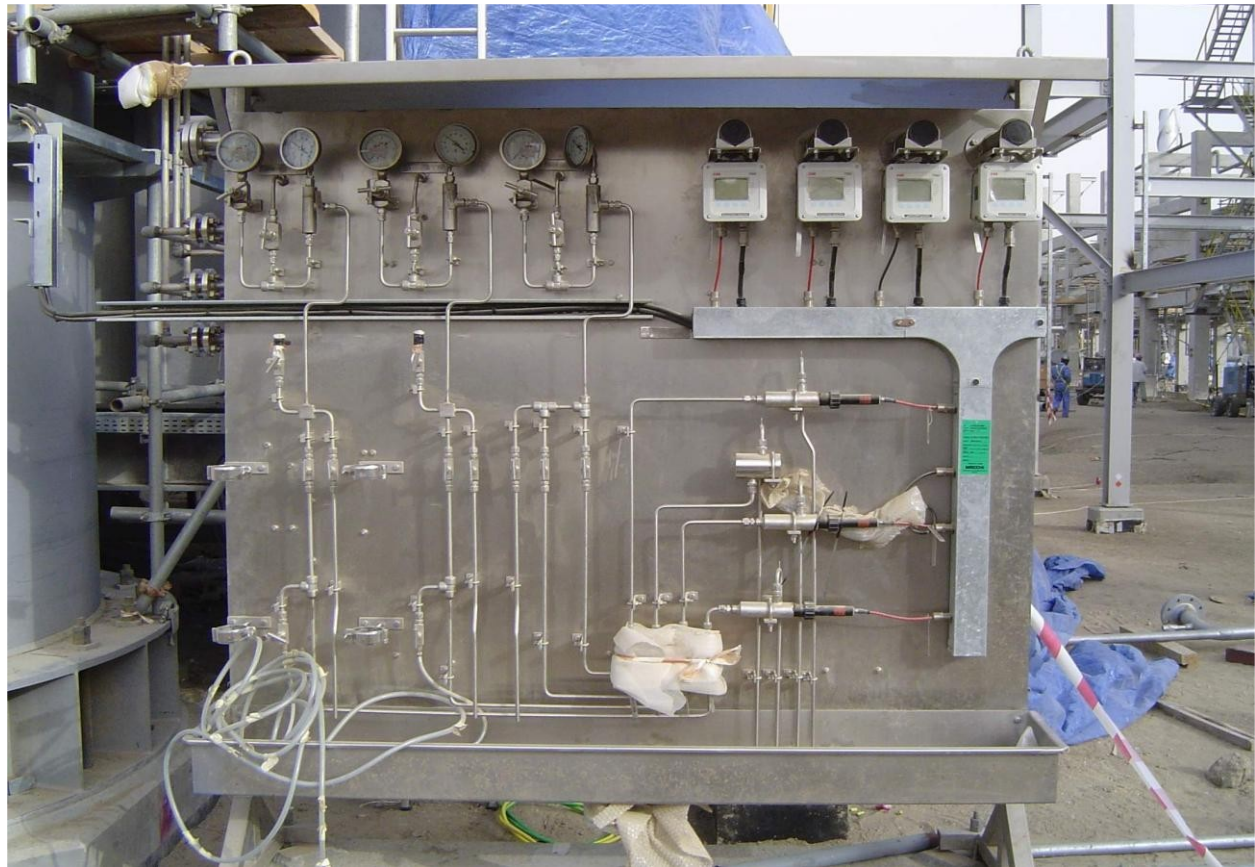

Analyzer Sampling System

# Control Room Panel Mounted

---

A circle with a **solid** line across its diameter and the lettered code above this line indicates a **control room panel** mounted instrument.

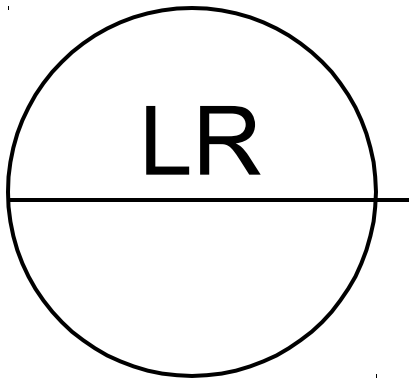

Open-type  
Control  
Panel

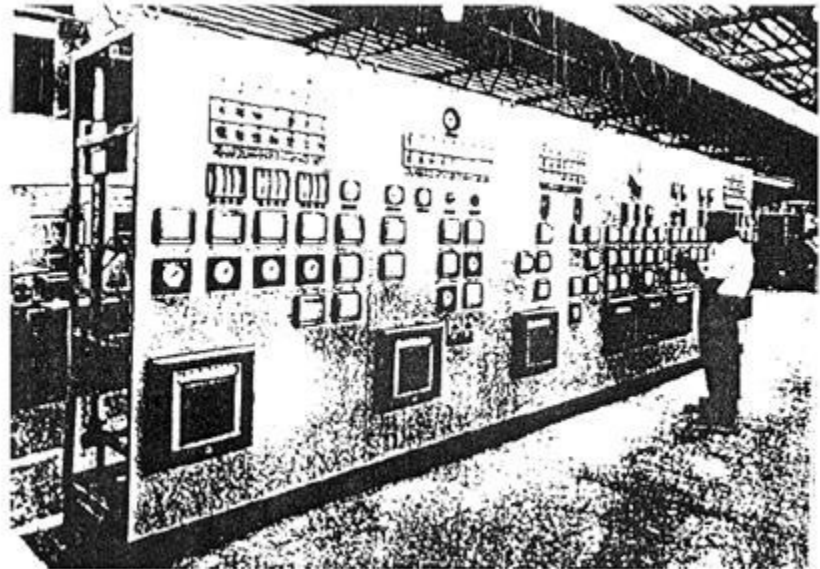

# Control Room Panel Mounted

A circle with a **solid** line across its diameter and the lettered code above this line indicates a **control room panel** mounted instrument.

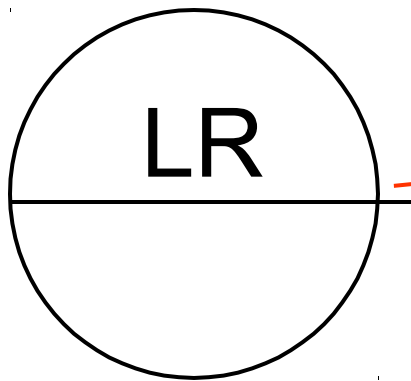

Open-type  
Control  
Panel

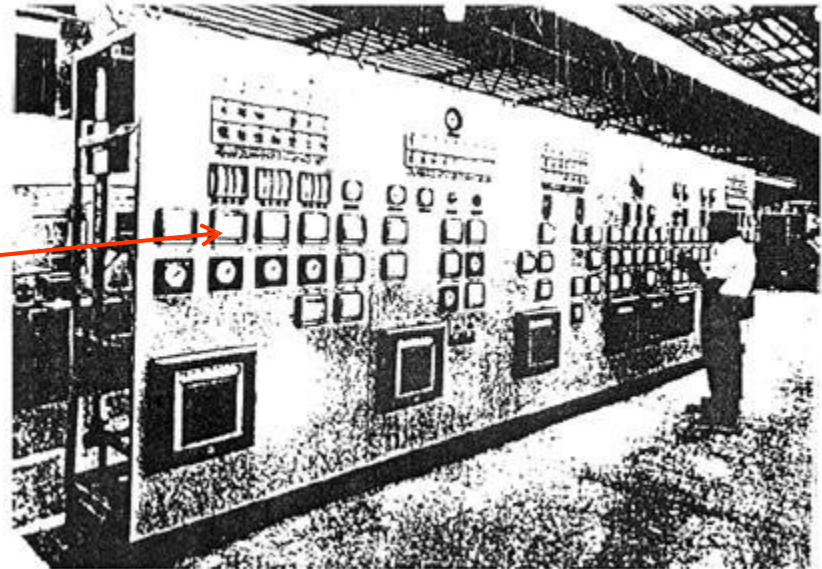



# Control Room Panel Mounted

Modern  
Conventional  
Control Panel

TR

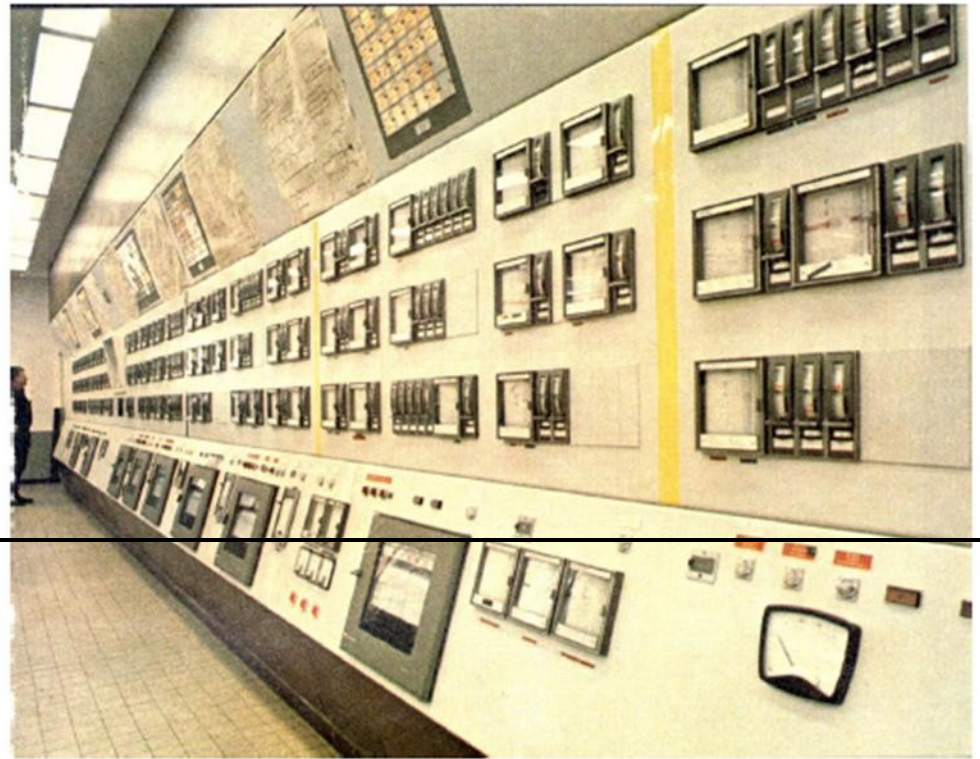

# Control Room Panel Mounted

Modern  
Conventional  
Control Panel

TR

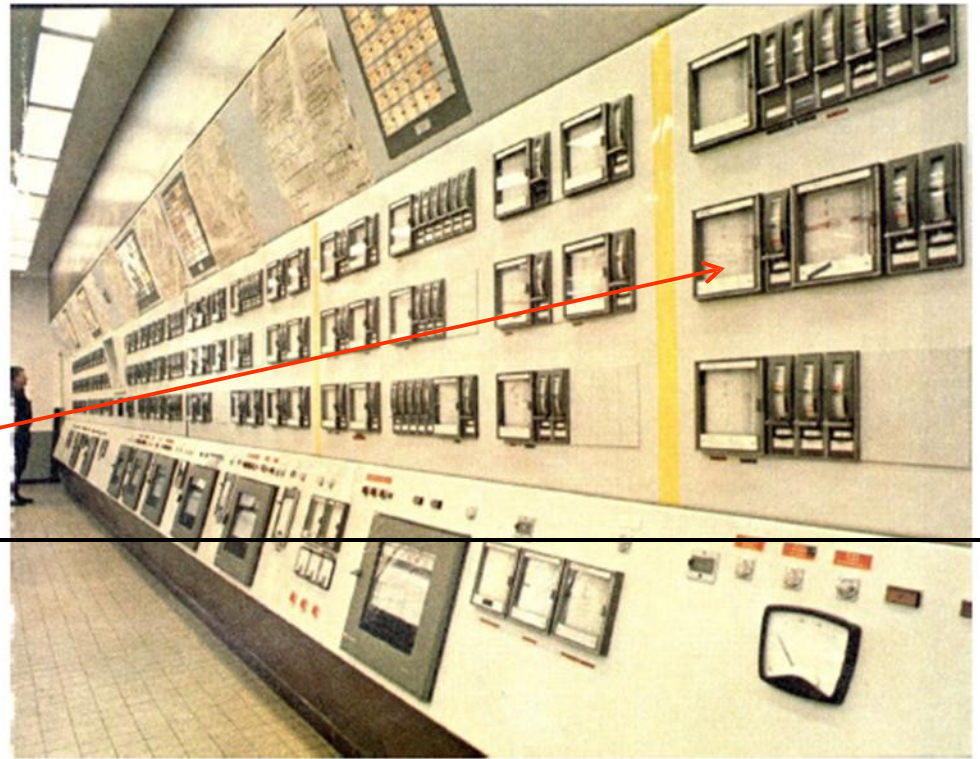

# Control Room Rack Mounted

---

A circle with a ***dotted*** line across its diameter indicates a ***control equipment room rack***, (i.e. usually behind the control panel), mounted instrument

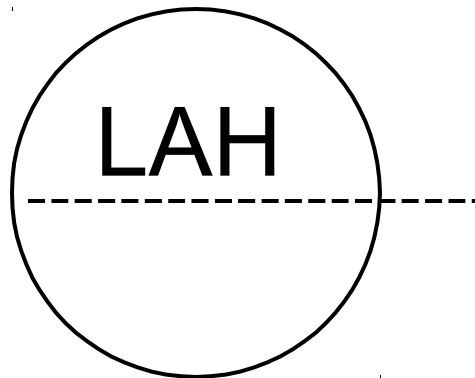

Closed-type  
Control Panel

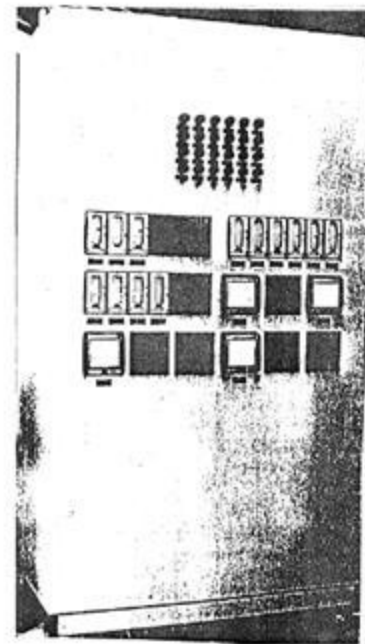



Panels





Panels



# Distributed Control Symbol

---

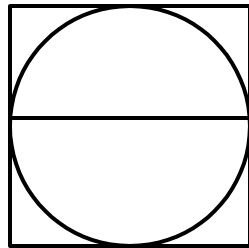

Video Display or  
Monitor, visible at  
console, accessible  
to operator

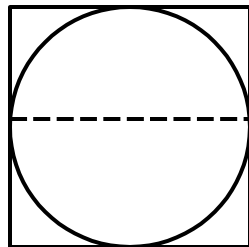

Video Display or  
Monitor, not visible  
at console, not  
accessible to  
operator

# Distributed Control Symbol

---

Modern  
DCS-type  
Control  
Console



# Distributed Control System - Console

---





Consoles

# P & ID LEGEND: Instrument Line Symbols

---

## ↳ Represent:

- ↳ Instrument and device connections to process measurement point.
- ↳ Connection to Instrument power supply
- ↳ Signals between measurement and control instruments and functions

# Instrument Line Symbols

---

Example:

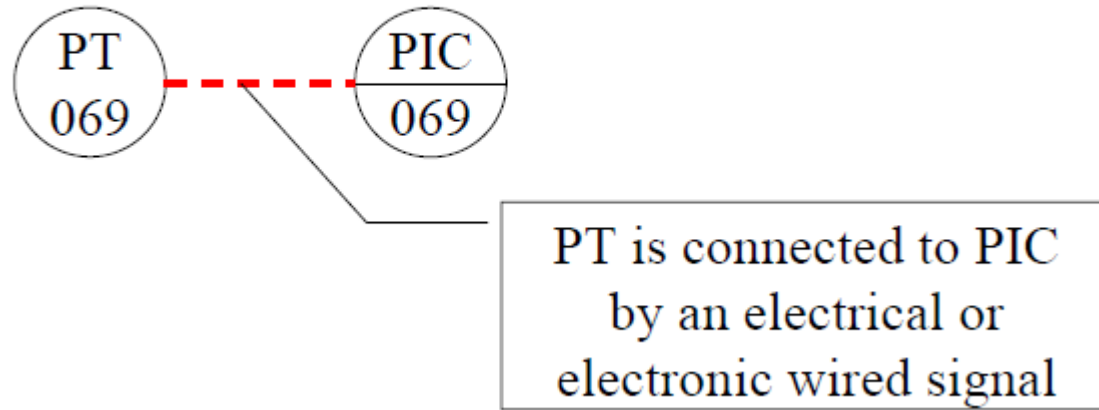

# Instrument Line Symbols

ALL LINES TO BE FINE IN RELATION TO PROCESS PIPING LINES.

(1) INSTRUMENT SUPPLY \*  
OR CONNECTION TO PROCESS

(2) UNDEFINED SIGNAL

(3) PNEUMATIC SIGNAL \*\*

(4) ELECTRIC SIGNAL

(5) HYDRAULIC SIGNAL

(6) CAPILLARY TUBE

(7) ELECTROMAGNETIC OR SONIC SIGNAL \*\*\*  
(GUIDED)

(8) ELECTROMAGNETIC OR SONIC SIGNAL \*\*\*  
(NOT GUIDED)

(9) INTERNAL SYSTEM LINK  
(SOFTWARE OR DATA LINK)

(10) MECHANICAL LINK

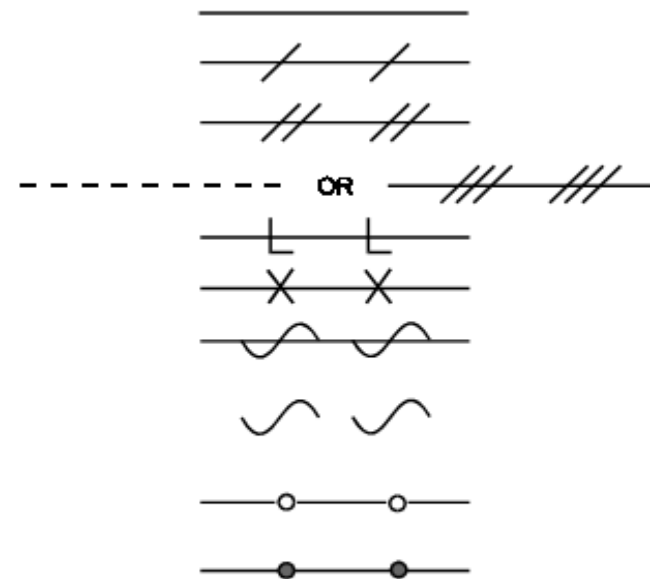

## OPTIONAL BINARY ( ON-OFF ) SYMBOLS





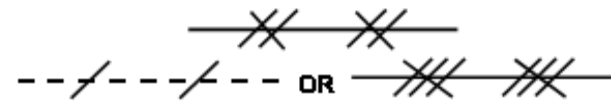





(11) PNEUMATIC BINARY SIGNAL

(12) ELECTRIC BINARY SIGNAL

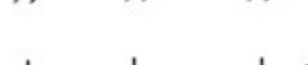

# Instrument Line Symbols

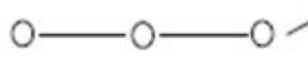
Types of line symbols:

	<b>Thick line</b> (piping & process equipment)
	<b>Thin line</b> (impulse piping or process conn.)
	<b>Broken line</b> (electrical or electronic signal)
	Pneumatic (air pressure) signal
	Hydraulic (oil pressure) signal
	Filled-system (fluid pressure) signal
	Electromagnetic or sonic signal ( <b>unguided</b> )
	Electromagnetic or sonic signal ( <b>guided</b> )
	DCS or computer data signal
	Mechanical link
	Undefined signal



# P&ID LEGEND: INSTRUMENT SYMBOLS



ORIFICE

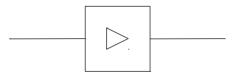

VORTEX



VENTURI

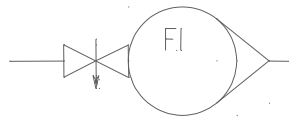

ROTAMETER (OR PURGE)  
(SHOWN WITH OPTIONAL  
INTEGRAL VALVE)

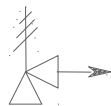

PRESSURE RELIEF  
OR SAFETY VALVE

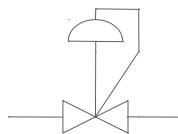

PRESSURE REDUCING  
REGULATOR  
(SELF-CONTAINED)



CONTROL VALVE (UNDEFINED)









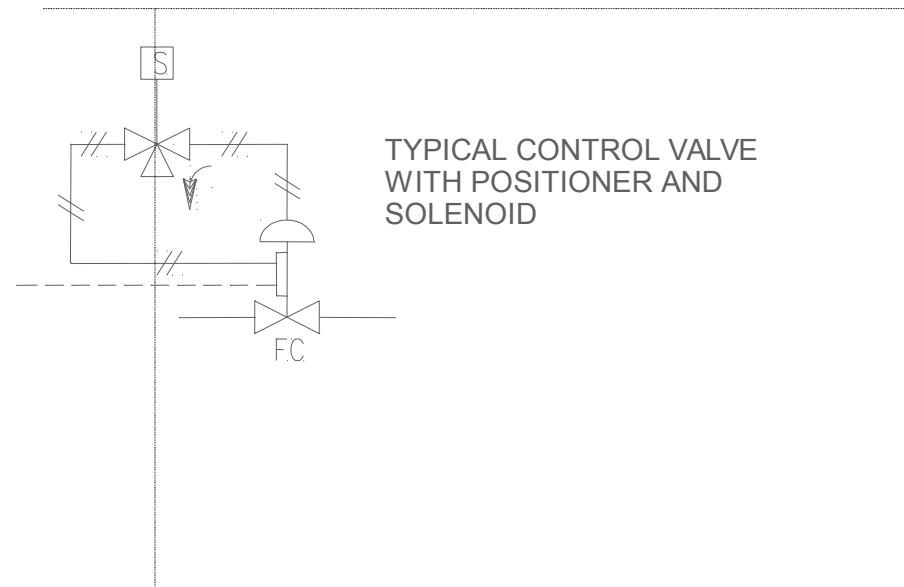









DIAPHRAGM



MOTOR OPERATED



# P&ID LEGEND: INSTRUMENT SYMBOLS

	PITOT TUBE		DRIFT PLATE W/FLANGES 1/NOTE 40
	FLOW NOZZLE		FLUME
	TARGET FLOW INSTRUMENT		METER
	PROPELLER FLOW INSTRUMENT		FLOW STRAIGHTENING VANE
	VORTEX FLOW SENSOR		VENTURI TUBE
	MAGNETIC FLOW INSTRUMENT		POSITIVE DISPLACEMENT FLOW INSTRUMENT
	SONIC FLOW INSTRUMENT		SENSOR DRIFT FITTINGS 1/NOTE 40
	AVERAGING PITOT TUBE		THERMAL FLOW METER
	AVERAGING PITOT TUBE BI-DIRECTIONAL		

# Valve Body Symbols

 GATE VALVE (SHOWN NORMALLY OPEN)

 GLOBE VALVE

 BALL VALVE

 CHECK VALVE

 ANGLE VALVE

 DIAPHRAGM VALVE

 DIVERTER VALVE

 BLOWDOWN ANGLE VALVE

 AUTO RECIRCULATING VALVE

 ANGLE STOP CHECK VALVE

 TANK DRAIN VALVE

 GATE VALVE NORMALLY CLOSED

 GLOBE VALVE NORMALLY CLOSED

 BALL VALVE NORMALLY CLOSED

 BUTTERFLY VALVE

 PLUG VALVE

 NEEDLE VALVE

 STOP CHECK VALVE

 3-WAY VALVE

 SPRING LOADED GATE VALVE

 DOUBLE DISC GATE VALVE W/ BLEED VALVE

 UNIT TANDEM VALVE

 CRYOGENIC VALVE  
NOTE 15

 CRYOGENIC BUTTERFLY  
NOTE 15

 BACKFLOW PREVENTER

 NORMALLY OPEN  
POST INDICATOR VALVE

 HYDRANT W/ 2 HOSES, OUTLET  
AND PUMPER CONNECTION







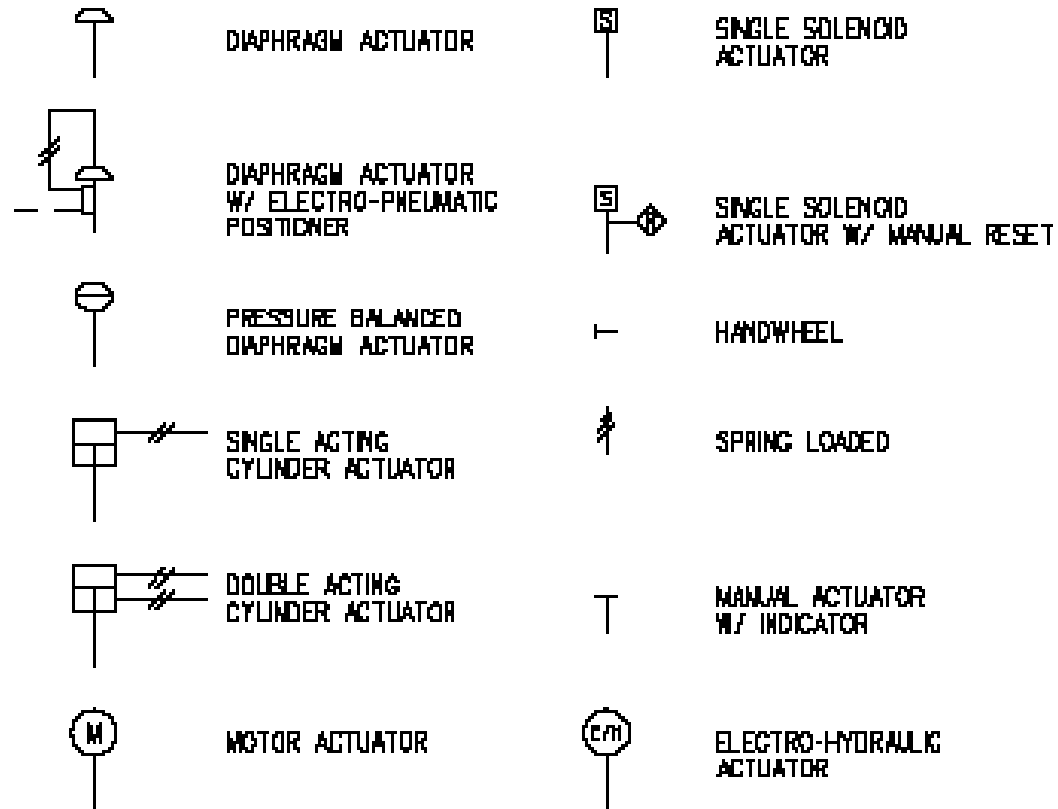







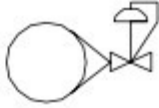

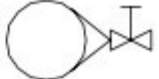





 HYDRANT W/ 2 HOSES, MONITOR  
AND PUMPER CONNECTION

 DELUGE VALVE

# Valve Actuator Symbols



# P&ID LEGEND: INSTRUMENT SYMBOLS

	GENERIC CONTROL VALVE		PITOT TUBE		VARIABLE AREA FLOW INSTRUMENT
	ANGLE VALVE		FLOW NOZZLE		VARIABLE AREA FLOW INSTRUMENT W/ DOWNSTREAM REGULATOR
	BALL VALVE		TARGET FLOW INSTRUMENT		VARIABLE AREA FLOW INSTRUMENT W/ DOWNSTREAM VALVE
	BUTTERFLY OR TRUNNION VALVE		PROPELLER FLOW INSTRUMENT		VORTEX FLOW SENSOR
	PLUG VALVE		MAGNETIC FLOW INSTRUMENT		FIELD MOUNTED PILOT LIGHT
	DIAPHRAGM VALVE		SONIC FLOW INSTRUMENT		AUXILIARY PANEL PILOT LIGHT
	3-WAY VALVE (WITH FAILURE POSITION)		AVERAGING PITOT TUBE		INSTRUMENT SHARING COMMON HOUSING
	4-WAY VALVE		AVERAGING PITOT TUBE BI-DIRECTIONAL		LEVEL GAUGES, MULTIPLE
			PRE-FAB ORIFICE RUN (NOTE 8)		

# P&ID LEGEND: INSTRUMENT SYMBOLS

	SELF CONTAINED BACKPRESSURE VALVE		ORIFICE PLATE W/FLANGES (NOTE 8)		HEAT TRACED INSTRUMENT
	SELF CONTAINED PRESSURE REDUCING VALVE		FLUME		
	BACKPRESSURE REGULATOR W/ EXTERNAL TAP		WEIR		CALIBRATED SIGHT GLASS
	DIFFERENTIAL PRESSURE REDUCING REGULATOR W/ INTERNAL AND EXTERNAL TAPS		FLOW STRAIGHTENING VANE		CHEMICAL SEAL
	FILLED SYSTEM TEMPERATURE REGULATOR		VENTURITUBE		POSITIVE DISPLACEMENT FLOW INSTRUMENT
	3-WAY SOLENOID VALVE (WITH FAILURE POSITION)		SENIOR ORIFICE FITTING (NOTE 8)		
	4-WAY SOLENOID VALVE		THERMAL FLOW METER		

# IN-LINE INSTRUMENTS

---

*Inline Instruments* are detailed with type and

connection size

→ Control Valves



→ Relief Valves





# IN-LINE INSTRUMENTS

## └─H Flow Elements/Meters

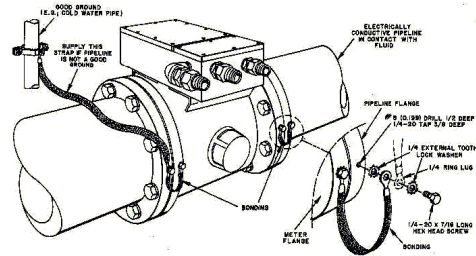
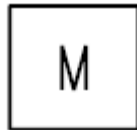
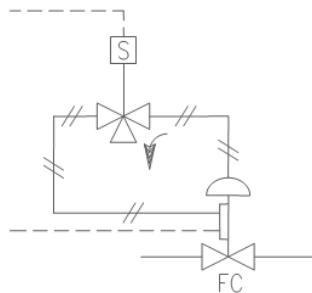

FIG. 2.26  
Typical bonding and grounding procedure.

## └─H Emergency Shutdown Valves



# Function Symbol

---

$\Sigma$	SUMMING	$\nabla$	HIGH LIMIT
$\Sigma/n$	AVERAGING	$\nabla$	LOW LIMIT
$\Delta$	DIFFERENCE	$-K$	REVERSE PROPORTIONAL
$K$	PROPORTIONAL	$\nabla$	VELOCITY LIMITER
$\int$	INTEGRAL	$+$	BIAS PLUS
$d/dt$	DERIVATIVE	$-$	BIAS MINUS
$\times$	MULTIPLYING	$\pm$	BIAS PLUS/MINUS
$\div$	DIVIDING	$\nabla$	CONVERSION INPUT/OUTPUT
$\sqrt{\quad}$	ROOT EXTRACTING	$\nabla P$	CURRENT/PNEUMATIC CONVERT

# Function Symbol

$\sqrt[n]{\quad}$	ROOT EXTRACTING	$I/P$	CURRENT/PNEUMATIC CONVERT
$X^n$	EXPONENTIAL	ALM	SIGNAL MONITORING
$f(x)$	UNSPECIFIED	REV	REVERSE ACTION (NOTE B)
$f(t)$	TIME FUNCTION	DIR	DIRECT ACTION (NOTE B)
$>$	HIGH SELECT NOTE 3	1-D	ON-OFF
$<$	LOW SELECT	$K \int d/dt$	PROPORTIONAL INTEGRAL DERIVATIVE

•	A	ANALOG	I	CURRENT
	B	BINARY	⊗	ELECTROMAGNETIC SIGNAL
	D	DIGITAL	P	PNEUMATIC
	E	VOLTAGE	R	RESISTANCE ELECTRICAL
	H	HYDRAULIC		



# Process Equipment Symbol

---

This represents a **special** or **unique** symbol given to a process equipment, such as vessels, tanks, drums, heaters or exchangers, pumps, mixers and agitators, fans, compressors, etc. These symbols are common with the mechanical and chemical engineering field.

# Process Equipment Symbol

---

Examples:

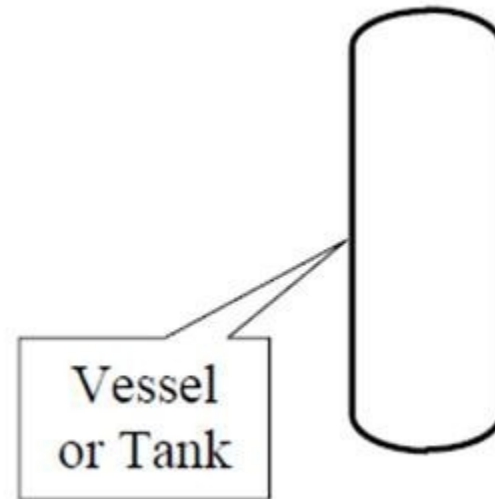
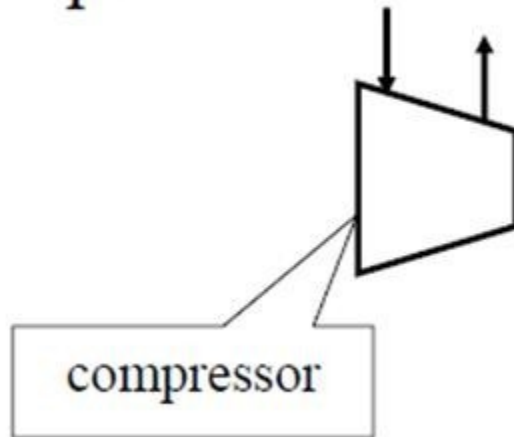

# Process Equipment Symbol

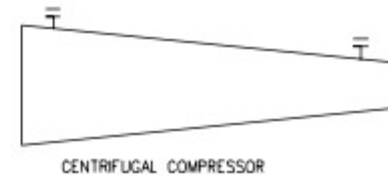
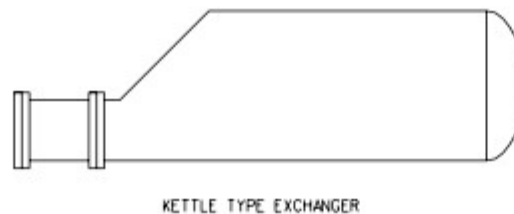
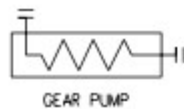
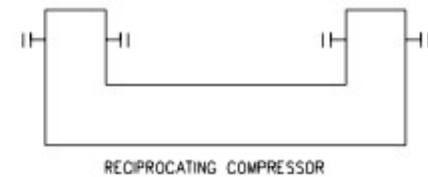
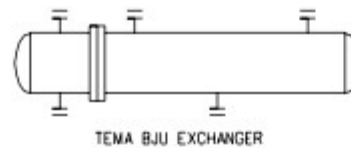
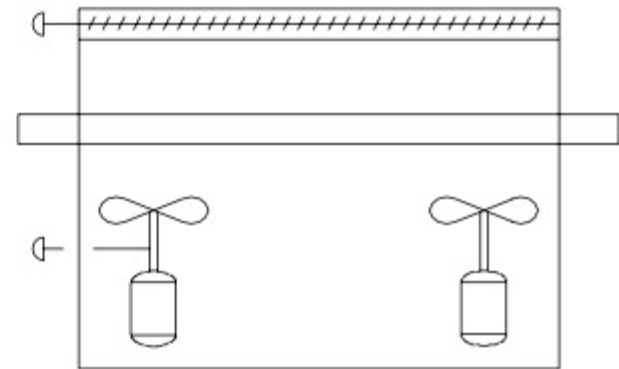
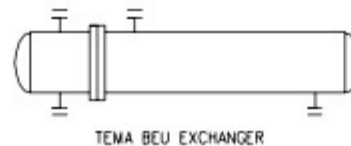
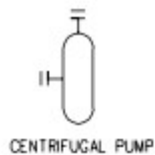

# Process Equipment Symbol

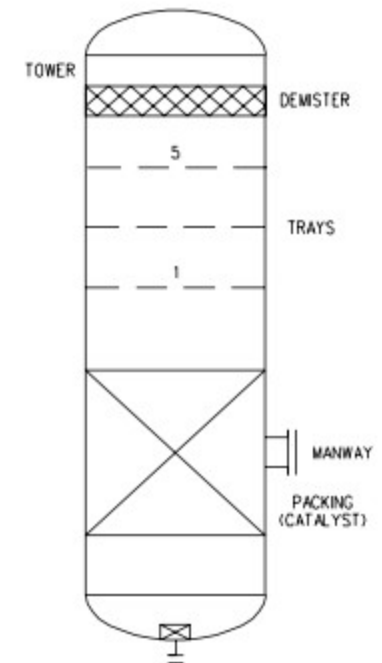
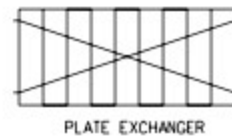
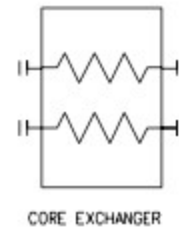
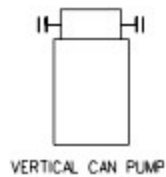
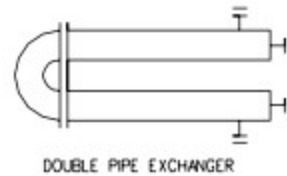
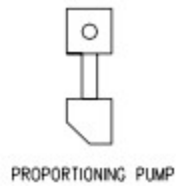



# Process Equipment Symbol

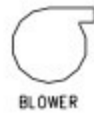

BLOWER



FAN

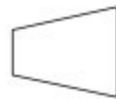

TURBINE DRIVER



MIXER



MOTOR



WEDGE WIRE FILTER



DIESEL ENGINE

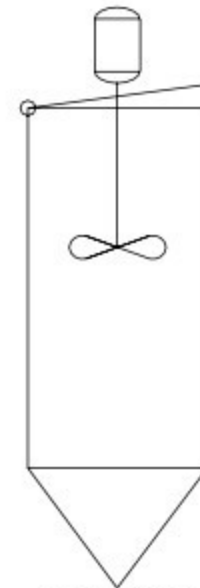

INHIBITOR INJECTION  
TANK W/MIXER

# Process Equipment Symbol

---



VERTICAL DRUM



HORIZONTAL DRUM

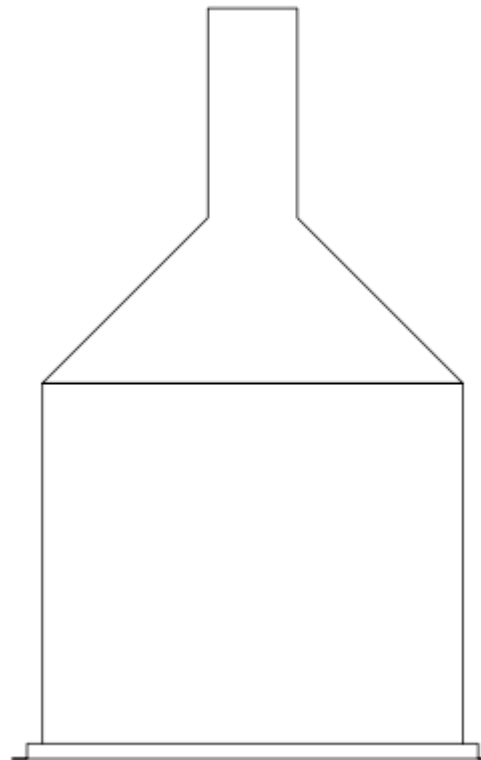

FIRE HEATER

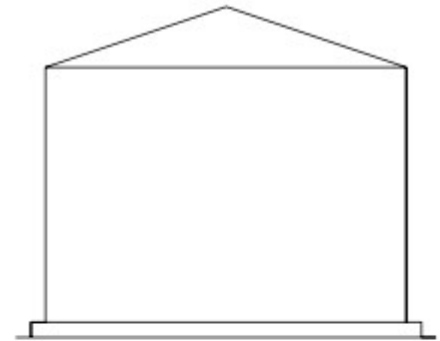

API STORAGE TANK

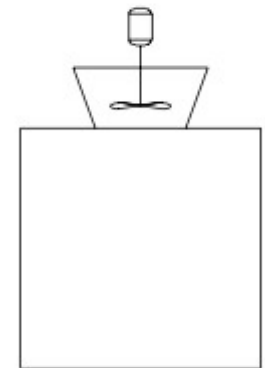

COOLING TOWER

# Process Equipment

---



# Process Equipment



# Process Equipment



Dehydrator

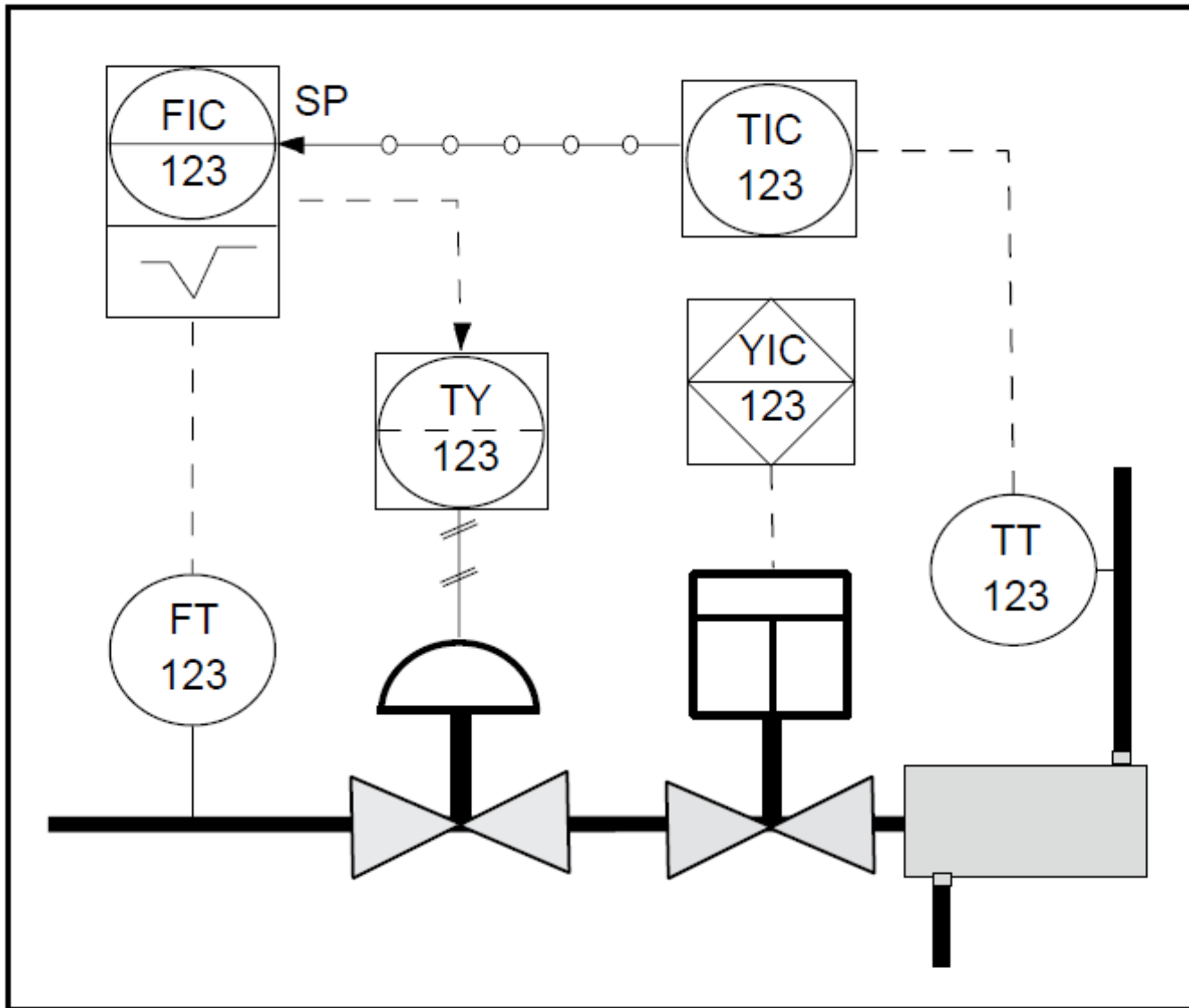

Piping and Instrumentation Drawing



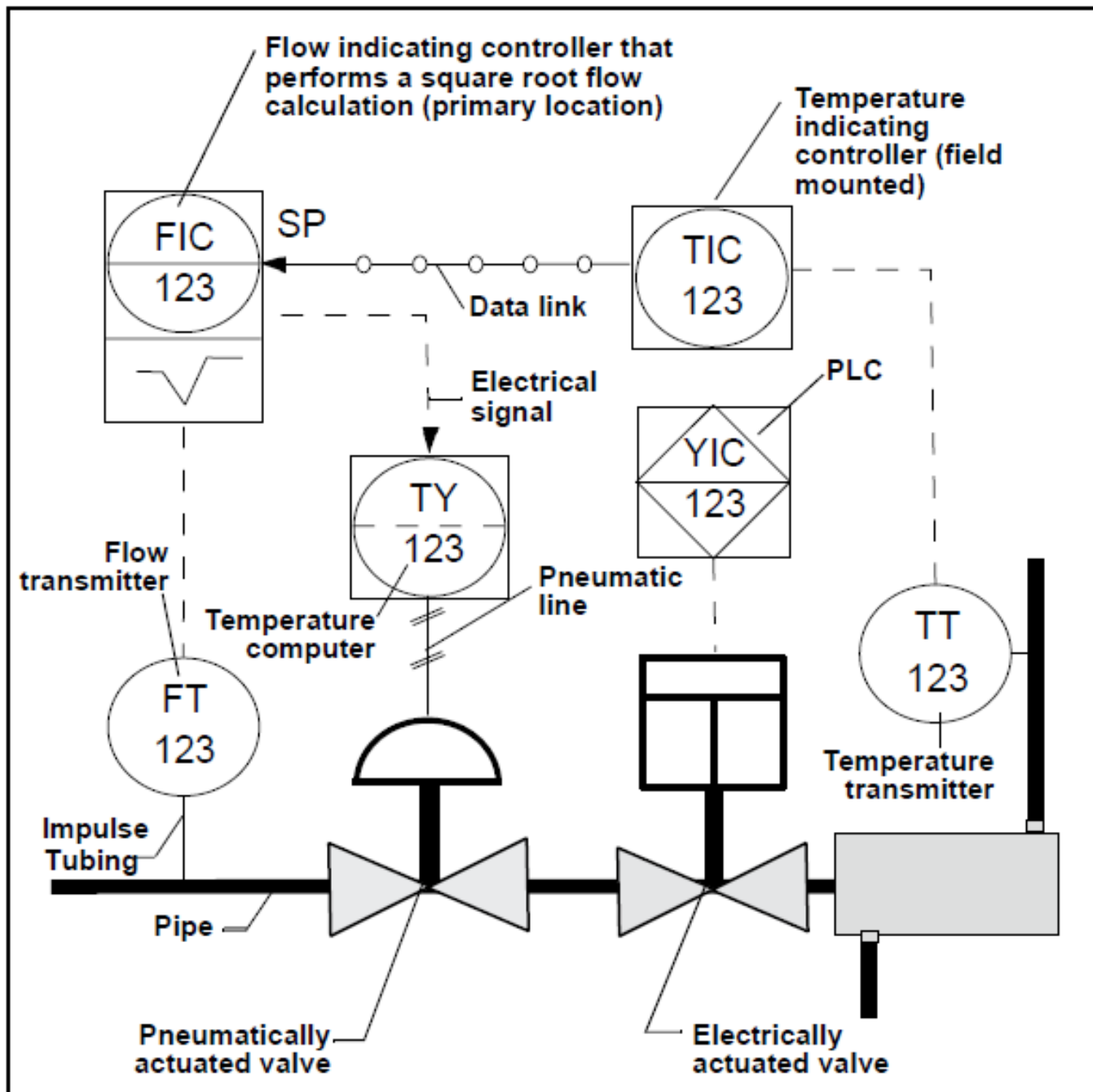



# TYPICAL LOOP

## Typical Temperature Loop with Valve Positioner

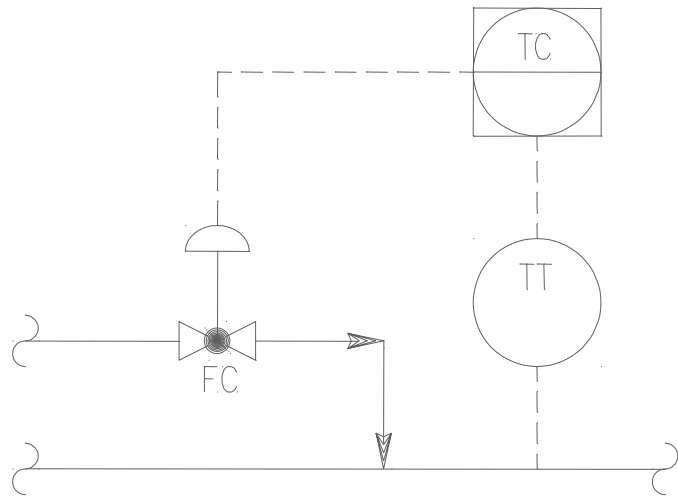

Shown on P&ID

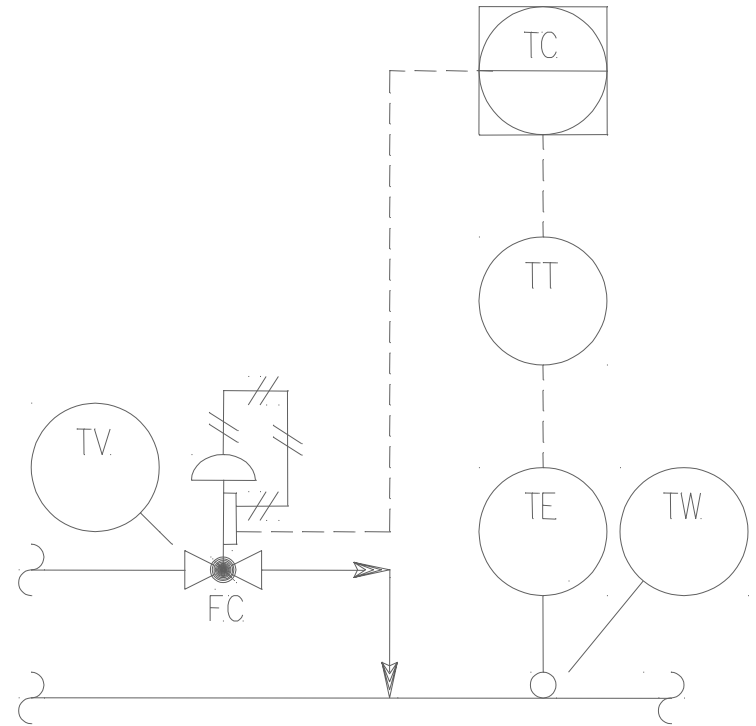

Implied

# TYPICAL LOOP

## Typical Flow Loop with Separate I/P

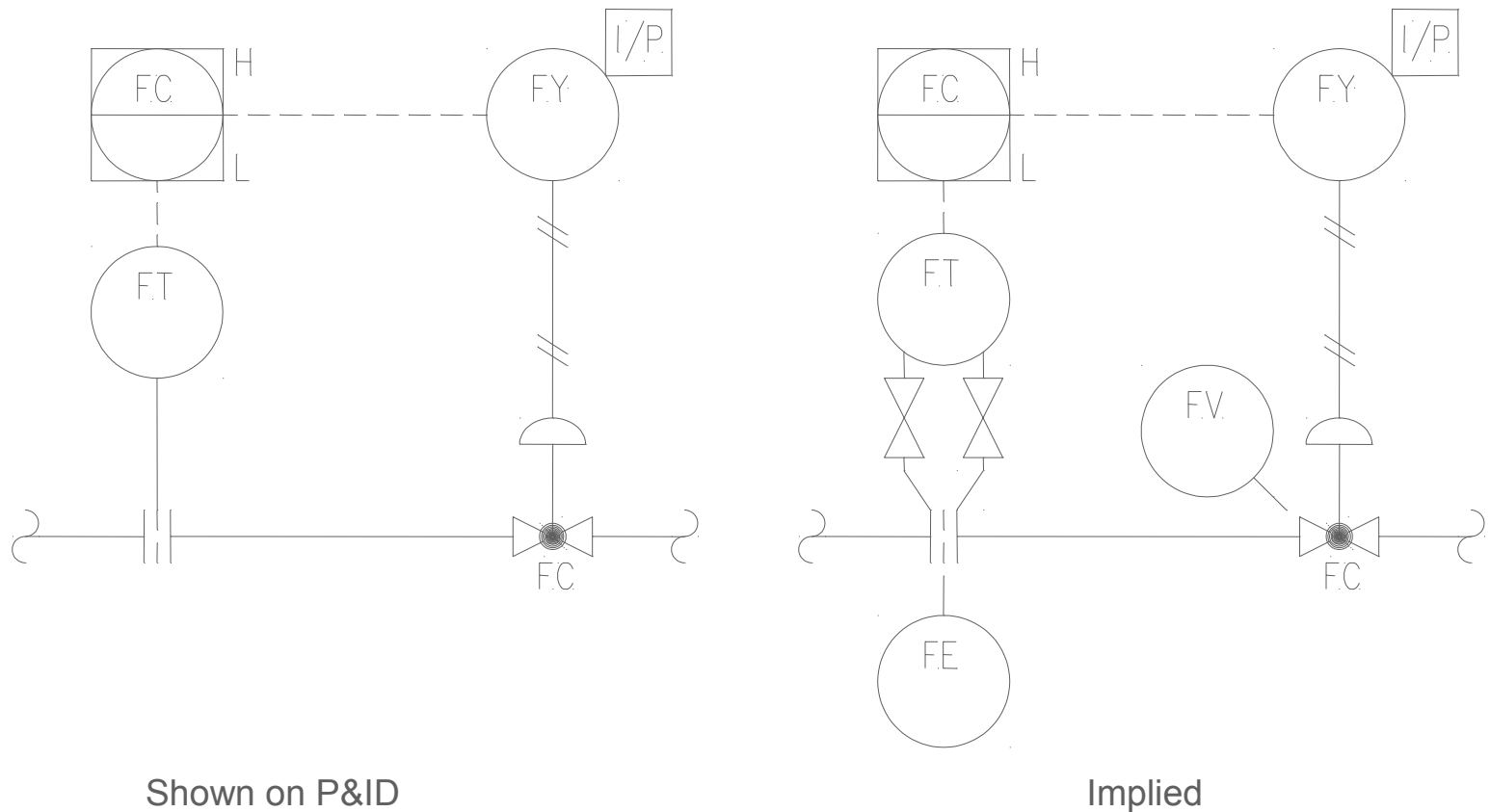

# TYPICAL LOOP

## Typical Valve Detail

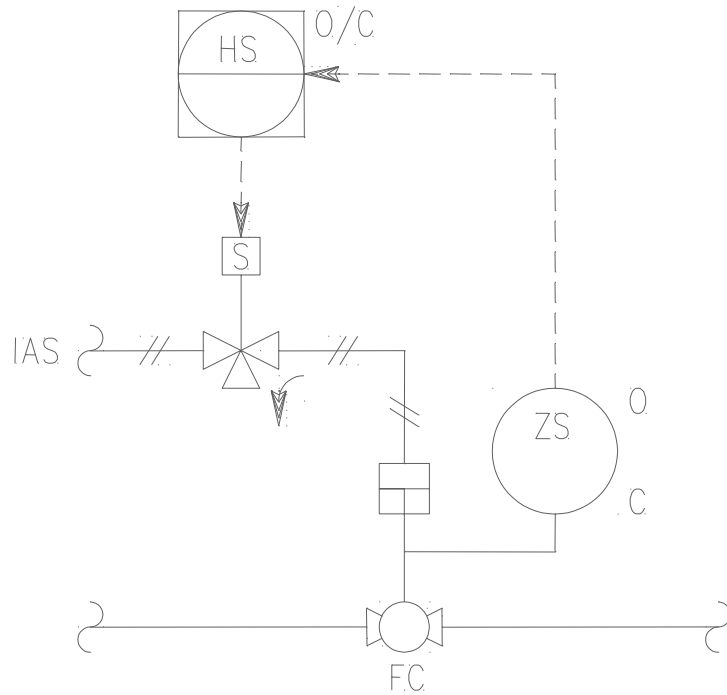

Shown on P&ID

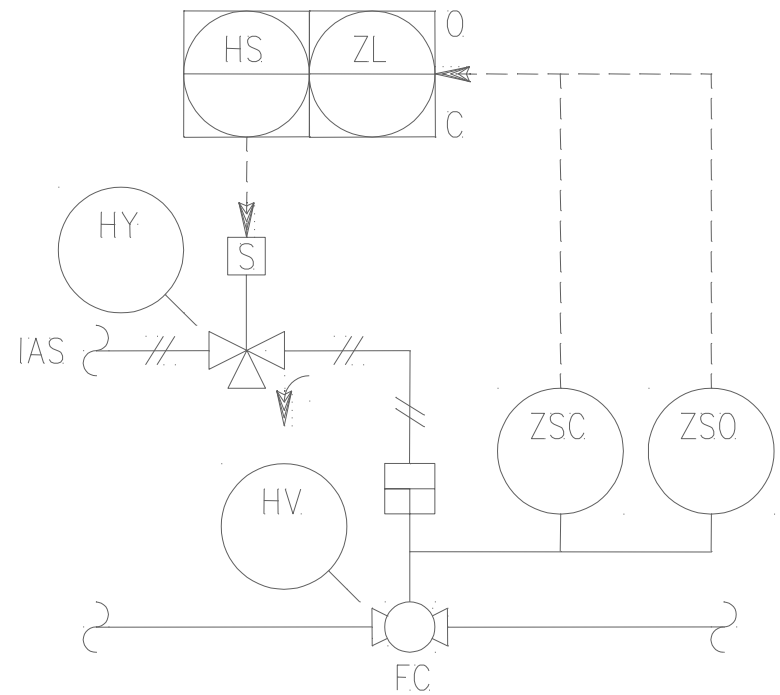

Implied

# P & ID EXAMPLE – Control Valve

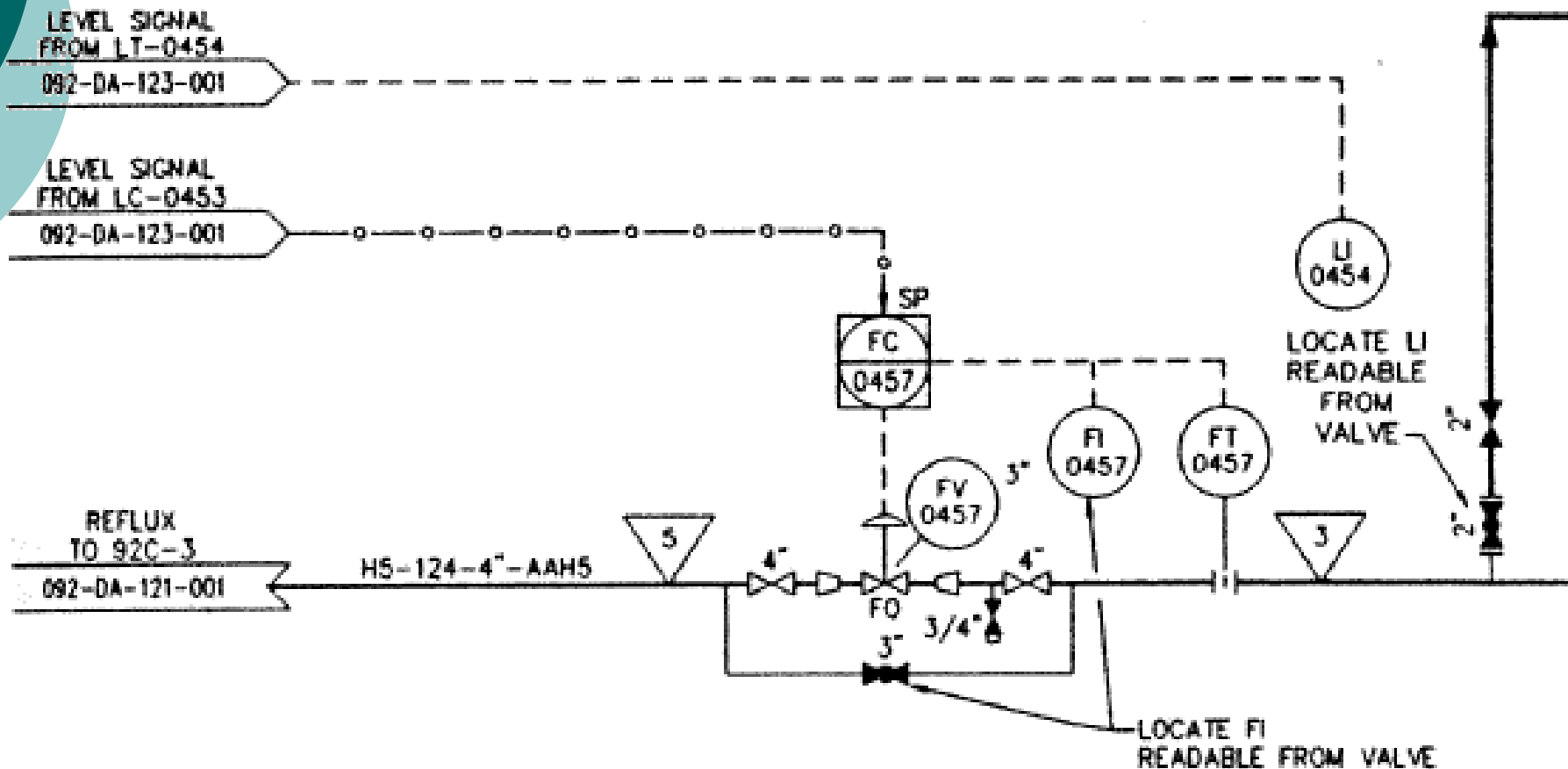

# P & ID EXAMPLE

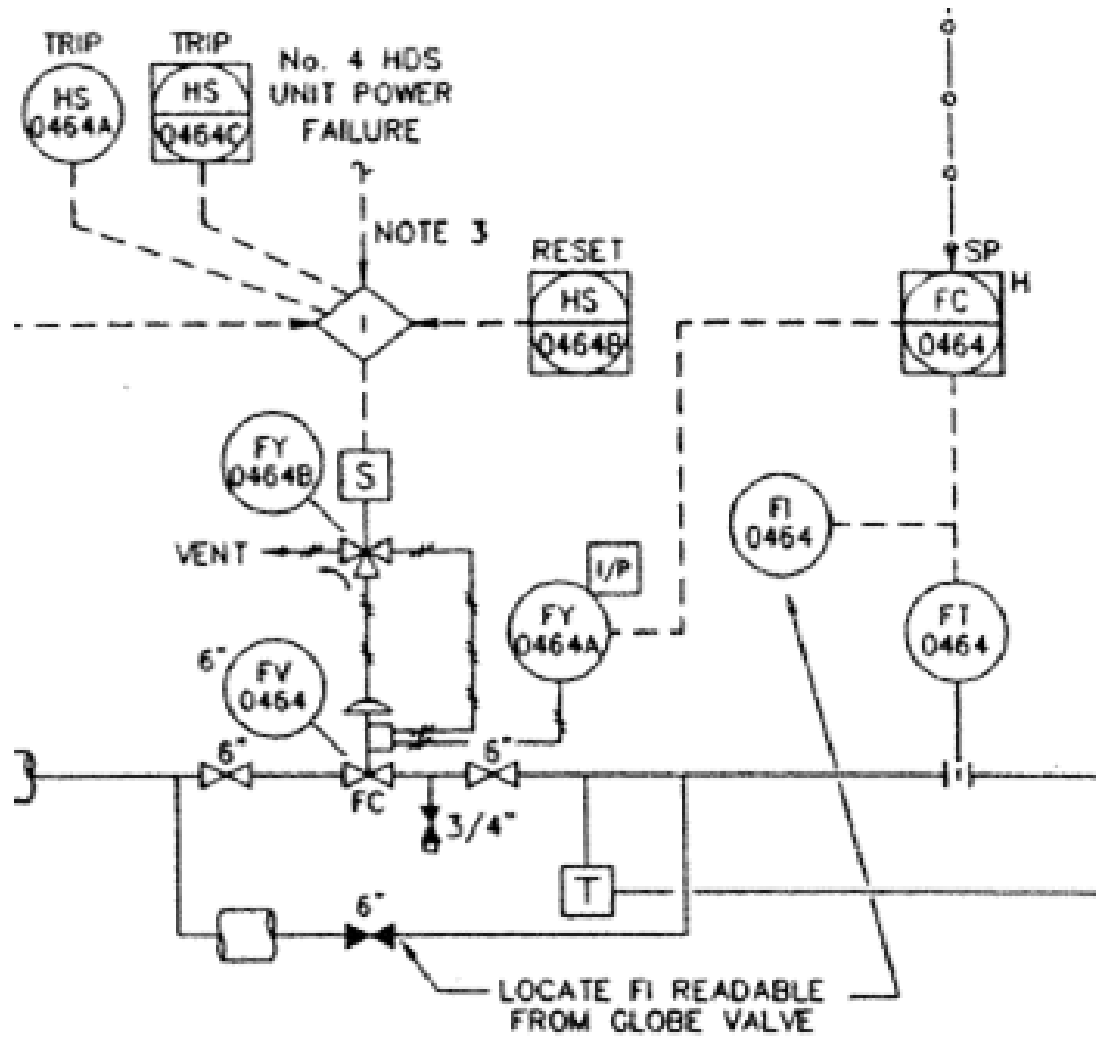







# P & ID EXAMPLE – Level Control (Electrical Traced)

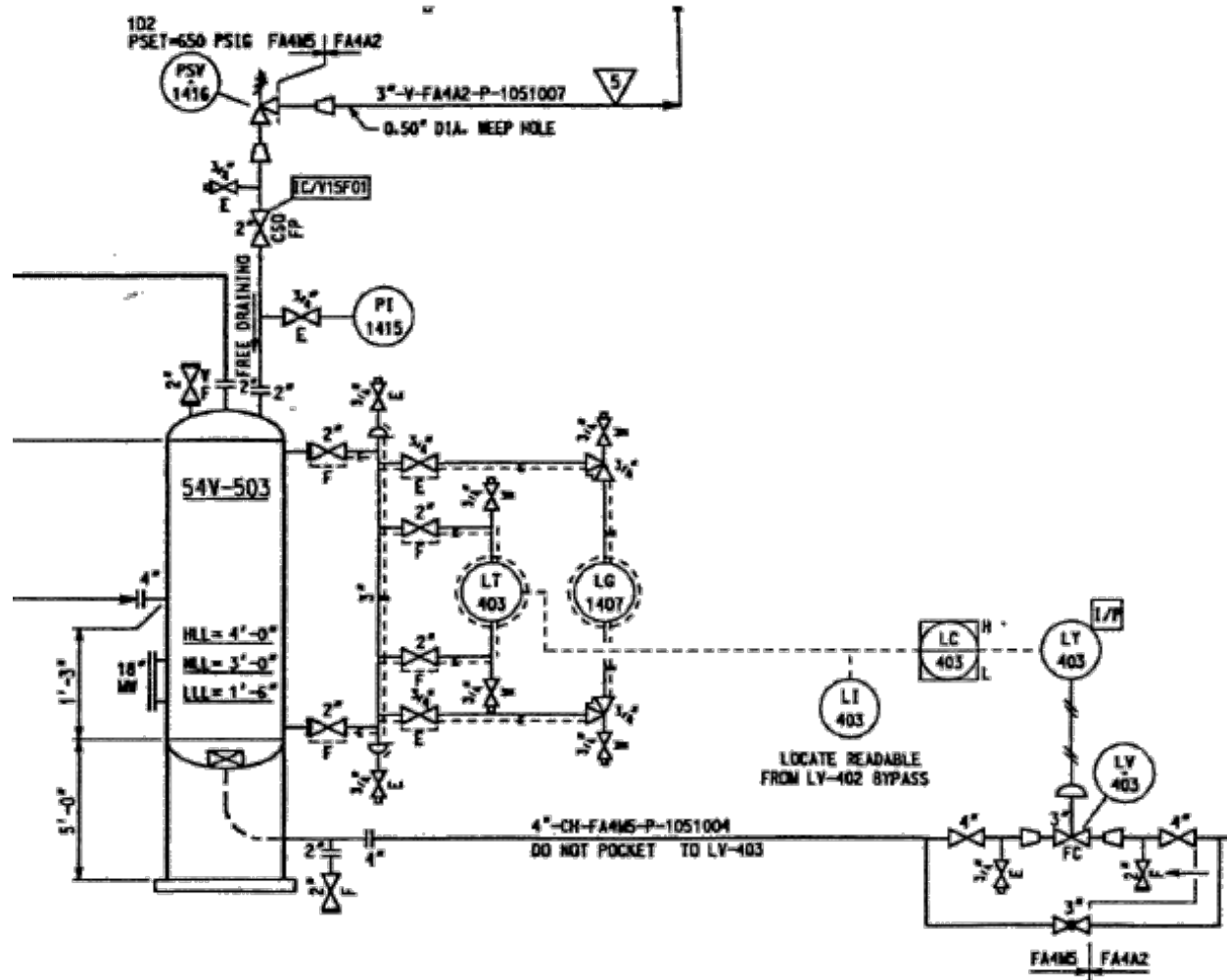

# P & ID EXAMPLE – Motorized Valve

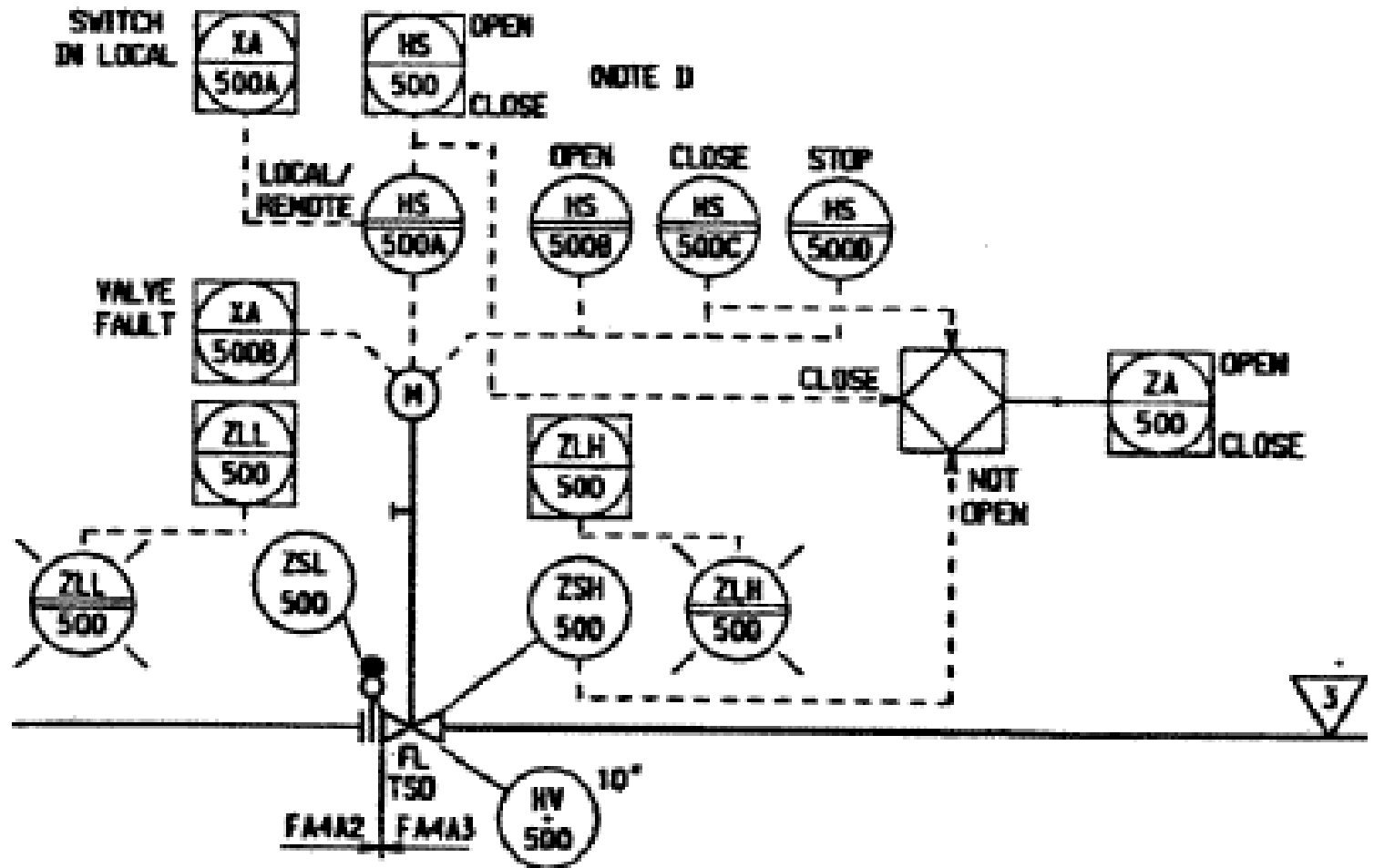

# P & ID EXAMPLE-Motor Control 1

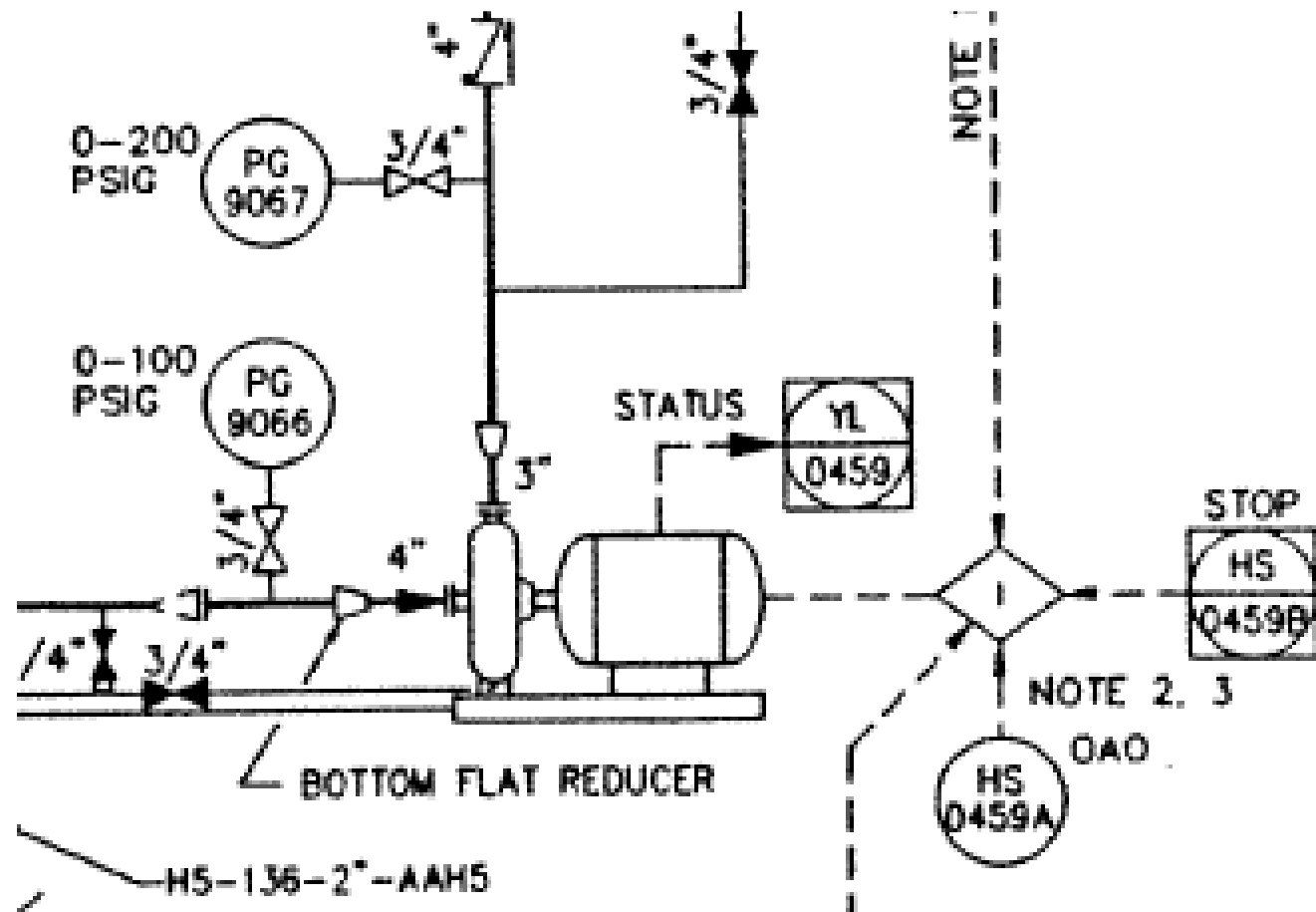

# P & ID EXAMPLE - Motor Control 2

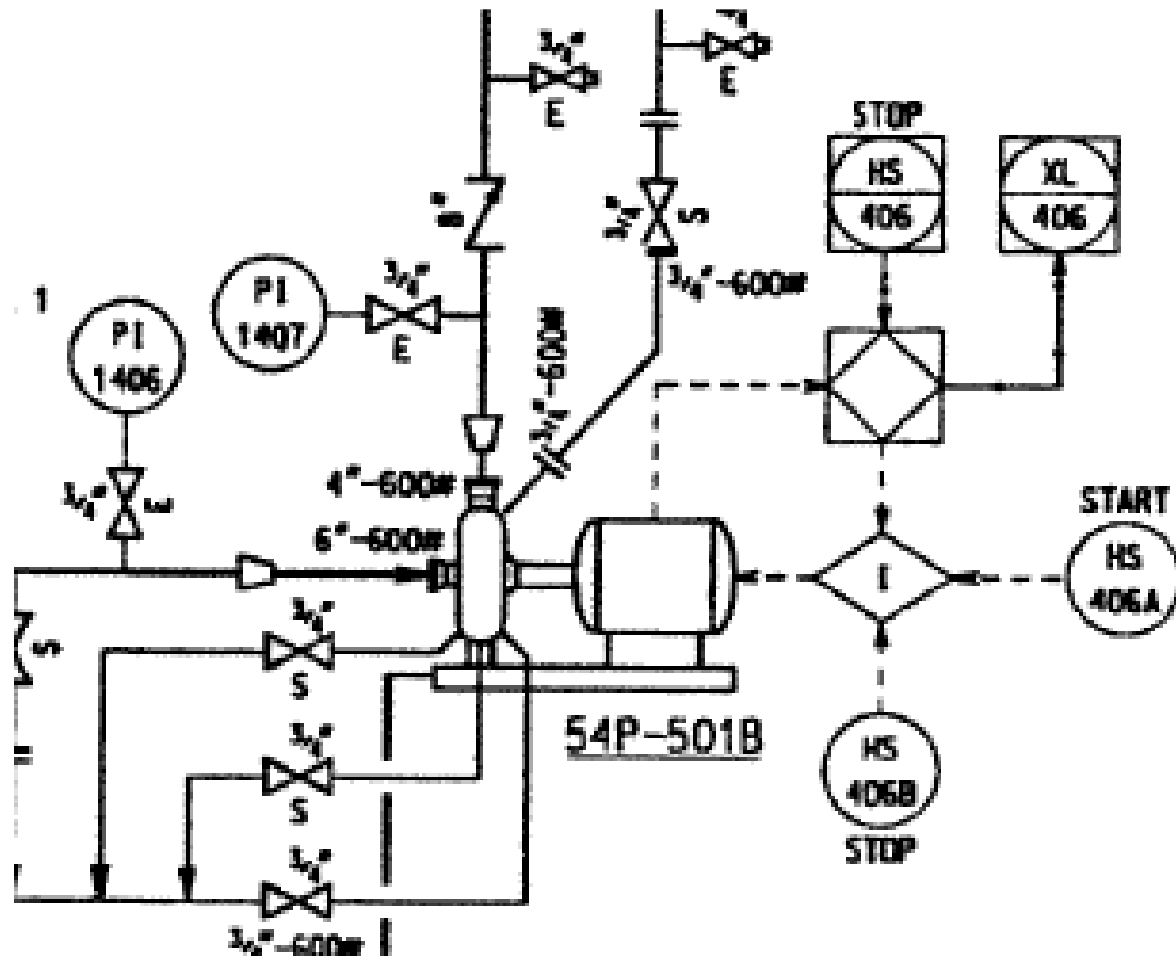

# P & ID EXAMPLE – Motor Control 3

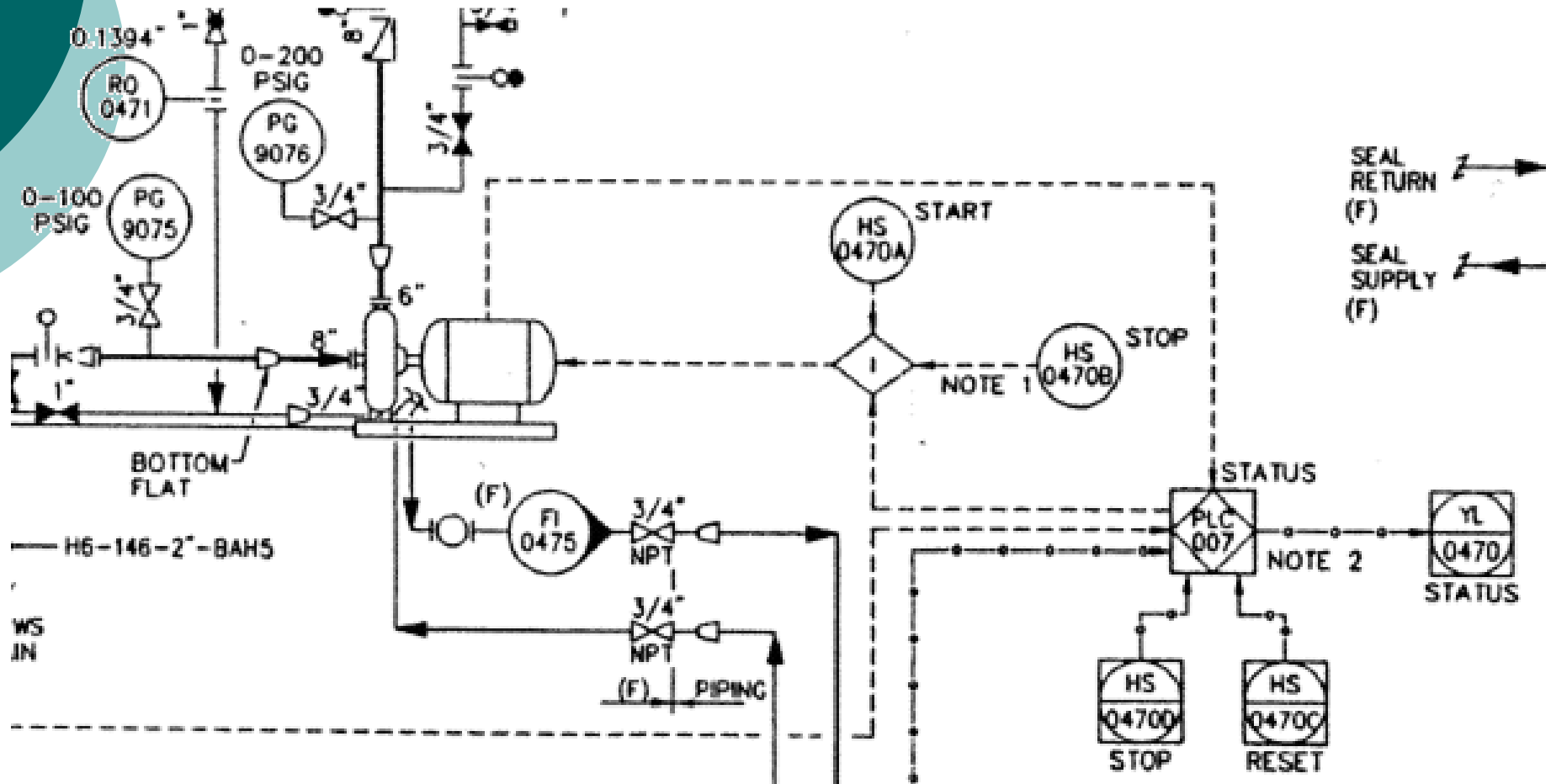





# P & ID REVIEW

---

- Symbology
- Consistency of Control Depiction
- Applicability of Measurement & Control Methods
- Correct Instrument Types
- System Operability

# UFD EXAMPLE

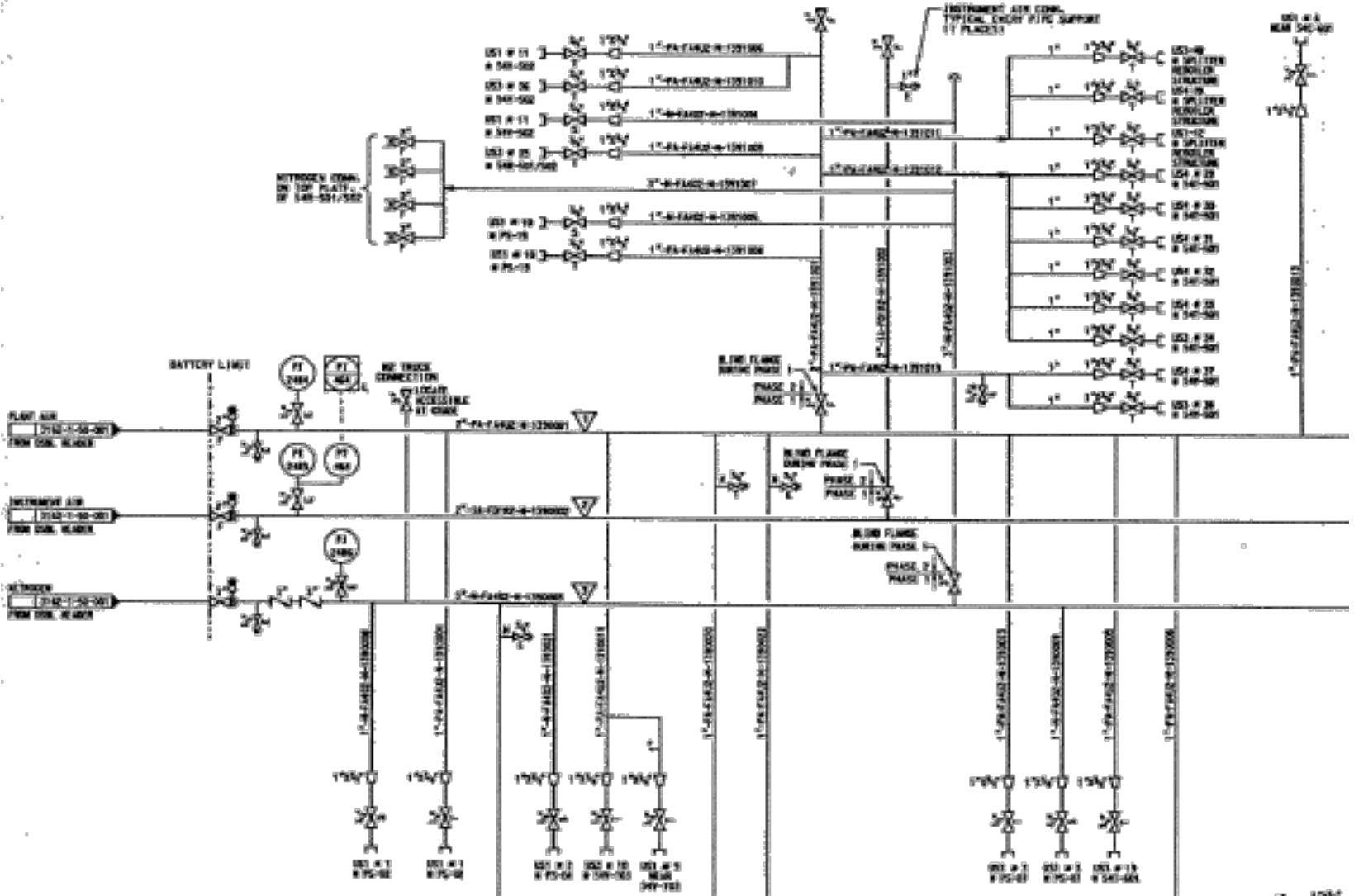



# AFD EXAMPLE

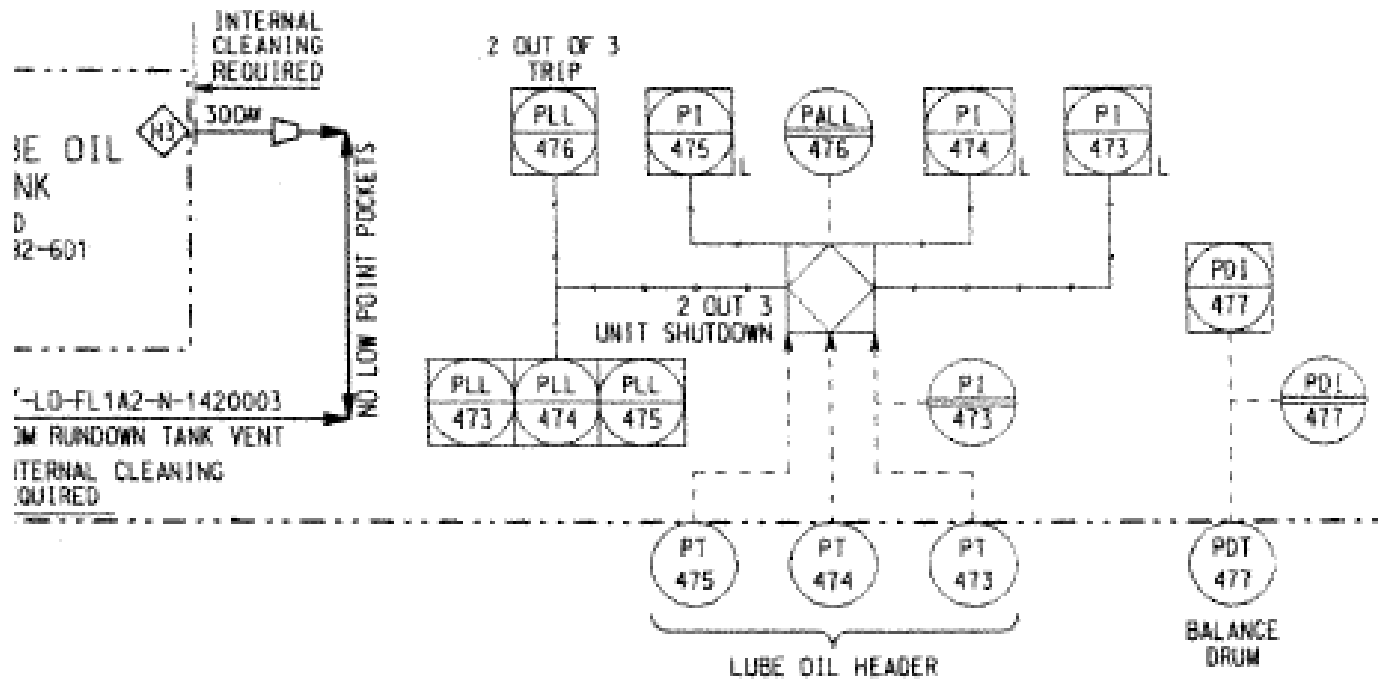

COMPRESSOR SKID DIAGRAM

DRESSER - RAND DRAWING NO. 179-490-601 (1 SHEET)

# AFD EXAMPLE

