



---

# Motors and drives

---

Introducing energy saving opportunities for business

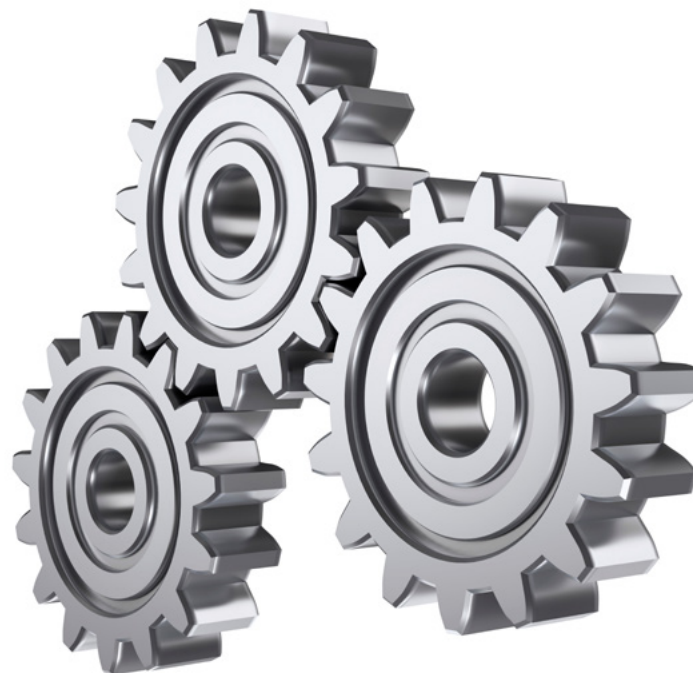

---

# Contents

---

Preface	3
Motors and drives in industry	4
Technology overview	5
Opportunities for energy saving in motor systems	9
Opportunities for energy savings with motors	15
Opportunities for energy savings with transmissions	19
New equipment	21
Motor management policies	24
Monitoring	26
Your next steps	28
Go online for more information	31

---

# Preface

---

Reducing energy use makes perfect business sense; it saves money, enhances corporate reputation and helps everyone in the fight against climate change.

The Carbon Trust provides simple, effective advice to help organisations take action to reduce carbon emissions, and the easiest way to do this is to use energy more efficiently.

This technology overview introduces the main energy saving opportunities for motors and drives. By taking simple actions you can save energy, cut costs and may increase profit margins.

# Motors and drives in industry

Most moving applications and many modern-day devices are powered by electric motors. These range in size from large industrial pumps to small office ventilation fans.

According to the World Energy Council, globally, electric motors and electric motor-driven systems are estimated to consume almost 50% of all electricity consumption and account for 70% of electricity consumption in industry.

The cost of buying an electric motor is only the start. In just a single year a running motor can cost up to ten times its purchase cost in energy. Typical running costs for a fully loaded motor are in the range £2,300/year for a 2.2kW motor to £39,000 a year for one rated at 37kW (assuming an electricity price of £0.12/kWh).

With this scale of running cost per motor, it is easy to appreciate why paying careful attention to the use and condition of motors is important. The cost savings arising from implementing energy saving initiatives across multiple motors can be huge.

This guide is intended for managers and users of electric motor systems. Both beginners and experts will benefit as it introduces the technologies and outlines some common energy saving opportunities, many of which apply in both small commercial and large industrial applications.

This guide focuses on the AC induction motor although many of the energy saving suggestions may also be applied to other motor types.

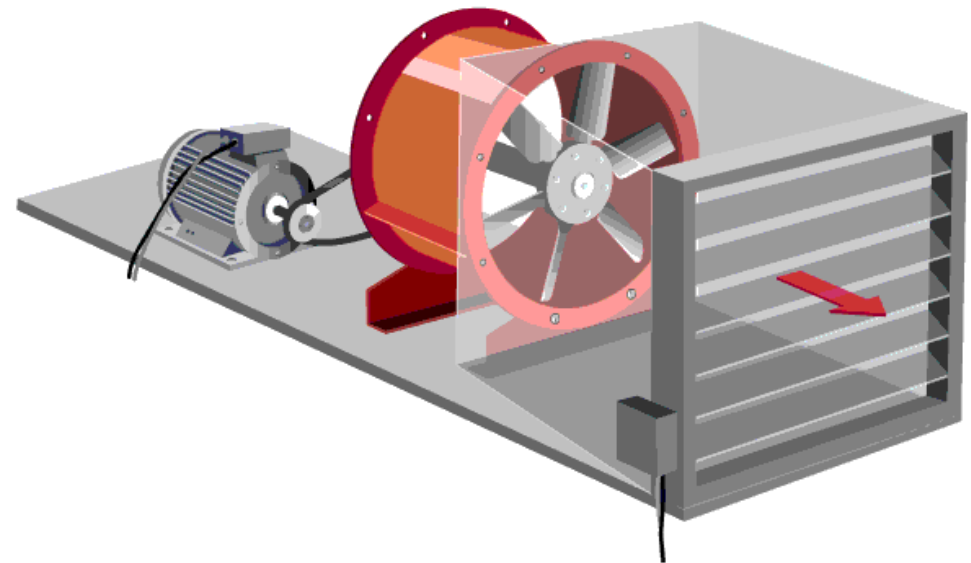

# Technology overview

Understand motors and be better able to detect wasted energy.

An electric motor converts electrical energy into rotating mechanical energy to drive devices such as pumps, fans or conveyors. The mechanical output power delivered by the motor is measured in kW and is a function of the speed (revolutions per minute (rpm)) and torque (the turning force applied).

Electric motors are available in standardised sizes and power ratings typically ranging from 10W to several MW. There are different types of motor, each of which has different characteristics, advantages and applications.

By far the most commonly used motor is the AC induction motor which uses conventional alternating electric current (AC) to induce a force (torque) on its rotor, causing it to rotate. When connected directly to an electrical supply, ordinary induction motors usually run at a single fixed speed although suppliers may offer

between two and three standard speed options per motor size.

The term 'drive' is used to mean many things in industry, including being used as a generic word for motors, for drive trains (such as gearboxes or pulley systems), and for motor controllers.

This guide covers a number of these technologies including variable speed drives (VSDs) which are electronic devices that control the electrical frequency to motors, enabling them to operate at different speeds. VSDs are discussed further on [page 7](#).

Due to the high energy savings potential that VSDs can bring, motors can also be purchased with an integrated variable speed control system.

Motors directly or indirectly rotate devices such as pumps, fans or compressors. These typically form part

of a larger system comprising pipes, valves, ductwork, controls and dampers. Ultimately, it is the system that delivers the desired function such as ventilating a space, or transferring a fluid from one location to another.

The interactions between the components that comprise the system will affect the overall performance. Therefore motors need to be understood within the context of the systems in which they operate; simply concentrating on the motor itself can mean that significant and often low-cost savings can be missed.

## Understanding the motor

Understanding the components of a motor and how it works, allows you to understand how energy can be wasted.

Figure 1 shows the parts that make up an induction motor, from the terminal box where the electrical input is connected either directly from the mains/grid supply or from a VSD, to the output shaft driving the load.

Figure 1 Cutaway view of an AC induction motor

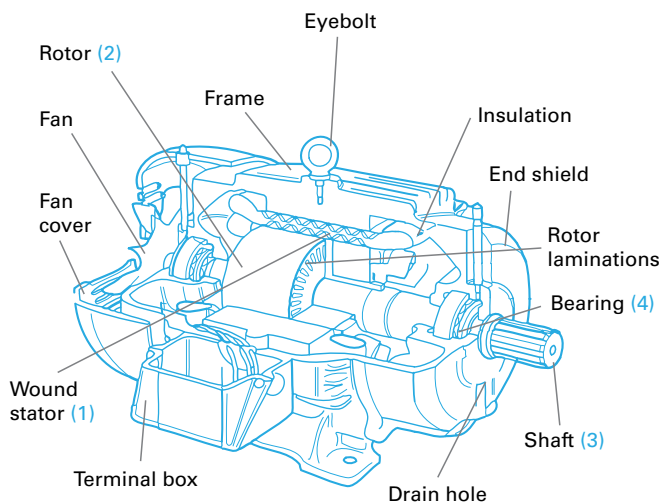

In summary, as electrical power is applied, a rotating magnetic field is created around the stator (1). This induces currents and associated magnetic fields in the rotor (2), causing the rotor and shaft (3) to spin. The shaft is mounted on bearings (4) and is able to rotate freely.

Energy is lost in the motor as the electrical energy is converted into mechanical energy. The main causes of this energy loss include: heating losses due to electrical resistances in the copper windings in the stator, and in the rotor bars; magnetic losses in the stator and rotor (iron losses); friction in the bearings and the air gap between the rotor and stator; and energy absorbed by the cooling fan. As a general rule, motor efficiency tends to increase with motor size.

When a motor is first connected directly to an electrical supply it rapidly accelerates to its fixed speed. During this start-up period the motor draws a very high current as it accelerates. Called the 'motor starting current' this is usually between four and eight times its standard rated current.

The starting current generates significant heat and it is for this reason that motor manufacturers normally state a maximum number of 'starts' per hour, as excess heat will reduce motor life.

The number of recommended starts per hour decreases with increasing motor size. For medium sized motors this is usually between four and eight. For large motors this may only be two.

When a motor is connected to a VSD or to a soft starter, the starting current can be limited and a much smoother start is possible. This reduces wear on the motor and on the system, and more frequent starting is possible. See [page 12](#) for more information on soft starters.

Information about an individual motor can be found on its name/ rating plate, and further detailed information is provided in the motor manufacturer's product literature. Motor rating/ name plates vary considerably. An example motor name plate is given in Figure 2:

Figure 2 Typical information provided on a motor name plate

Rated voltage	Manufacturer Name		Efficiency class
	Model No		Winding configuration
Rated power	Serial No	Poles	Rated amps
Nominal speed	400 V	29 A	Power factor
	15 kW	50 Hz	Mains supply frequency
Ingress protection rating	1430 u/min	INS	
	IP 55		

## Variable speed drives (VSDs)

Whilst there are a number of variations in VSD design; they all offer the same basic functionality. They convert the incoming electrical supply of fixed frequency and voltage into a variable frequency and variable voltage feed to the motor, with a corresponding change in the motor speed and torque. The motor speed can be varied from zero through to typically 120% of its full rated speed. Up to 150% rated torque can be achieved at reduced speed.

Modern VSDs generally offer computing intelligence and are able to be connected to a variety of control systems and sensors. Using a VSD controlled motor enables a better match of the driven machine to the requirements of the process. In applications requiring variable speed and variable torque, such as fans and pumps, using a VSD can make significant energy and cost savings.

See Guide [Variable speed drives technology guide \[CTG070\]](#) for further information.



Figure 3 Variable speed drive. Image courtesy of IMO Precision Controls.

## System losses

In a motor driven system, energy is transformed from one state to another by its component parts before it is finally able to do useful work, with some energy being lost at each stage.

The diagram on [page 8](#) illustrates how only a proportion of the electrical energy supplied is ultimately transmitted to the air being moved in a VSD controlled fan system.

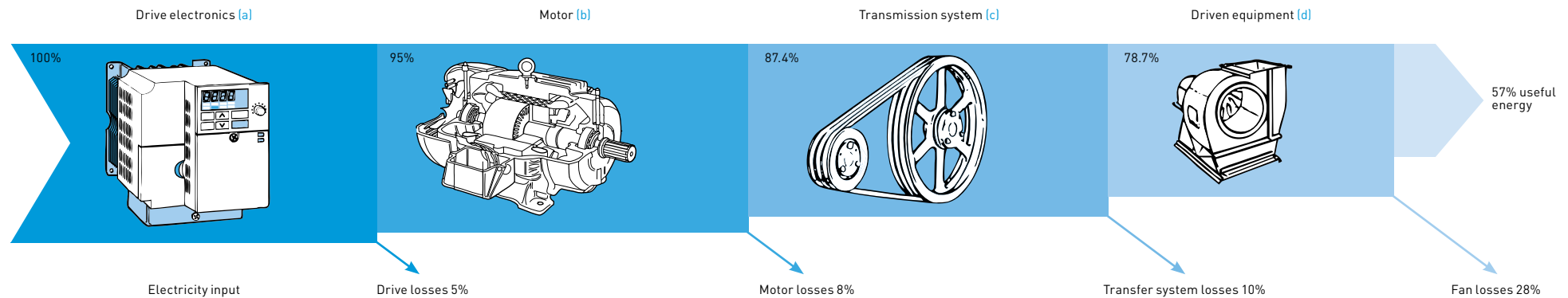

Figure 4 Typical system losses

In the example, the drive unit (a) requires electricity to power the electronics; some of this is lost as heat in the drive unit (typically 5%). The motor (b) has various internal losses, and if it is attached to a transmission system (c) for example, a gearbox or pulley, then this introduces further losses in the form of friction. The driven equipment such as the fan (d) also loses energy in the process of transferring the mechanical energy to the air.

Therefore in this example only 57% of the energy supplied to the motor system is transmitted to air flow. The majority of the losses appear as heat. Further frictional losses occur in the system as the air is forced through ductwork, dampers and filters, heat exchangers, and related equipment.

## Load types

Motors can drive a variety of load types. It is important to consider these when identifying the best energy saving opportunities. The load types are:

**Variable torque loads.** On loads of this type (for example many centrifugal fans and pumps) the torque varies with the change in speed squared, and the power varies with the change in speed cubed. In essence, this means that any speed reduction will save large amounts of energy, for instance a 20% speed reduction will result in up to approximately a 50% power saving.

**Constant torque loads.** On loads of this type (for example: conveyors, screw and reciprocating compressors, crushers, and surface winders) torque does not vary with speed and the power is directly proportional to speed. In essence, this means that the

power consumed will be in direct proportion to the useful work done; whilst the potential energy savings from speed reduction are less than with variable torque loads, they are still worth investigating. Typically a 50% speed reduction will result in 50% less power being consumed.

**Constant power loads.** On loads of this type (such as machine tools and centre winders) torque varies with speed, but power is constant. In essence, this means that there will rarely be any energy saving for any reduction in speed.



# Opportunities for energy saving in motor systems

Simple actions lead to significant savings.

## Switch-off policy and stop-start control

Because motors are so common and often 'hidden' within machinery, they tend to be ignored and left running even when they are not doing useful work. For example, watch what happens to motor-powered equipment when there is no production during a tea break or job change. Is it left running when not required? Other examples include circulating water in heating or cooling systems when there is no demand, or ventilating unoccupied spaces.

Once equipment has been identified that could be switched off, consider how it could be safely switched off. What is required to switch it off and on and how easy it is to implement? Assess what the risks are, for example what is the potential for the operator to switch off the wrong motor or switch off at the wrong time, and are there any health and safety risks to personnel?

Where manual switch off is appropriate, put procedures in place for all relevant motors to be switched off. This may involve writing a switch-off procedure and placing instructions where operators can easily see them. Such a procedure should also take into account the maximum number of 'starts' allowed for each motor, plus any warm up or initialisation time.

Consider whether it is possible to switch-off automatically. A timer could be used to switch off motor powered equipment at specified times. Interlocks could also be used so that equipment is switched on only if another device is already running. If the other device is turned off, the interlocked device will also automatically shut down. There are load-sensing devices available that can sense when there is no load on the motor, allowing it to switch off after a suitable time period, saving energy. Examples include: level sensors in tank filling applications; timers or CO<sub>2</sub> sensors in building

ventilation systems; and using load cells or interfacing with batch controllers on conveyors.

Other devices, such as sequencers, can be used to switch parallel equipment on and off according to the process needs. For example, only switch on one extraction fan in a bank of several during low-load conditions.

See guide [Implementing automatic switch off \(stop-start\) controls on electric motors \(CTL159\)](#) for further information.

## Minimising demand and process optimising

Minimising the demand placed on a system or optimising the process can lead to significant energy savings.

Careful analysis of the process requirements will identify opportunities to reduce the demand; these could vary from reducing the throughput to reducing operating set points such as temperature or pressure settings.

A system can be designed to match the demand, such as the throughput rates matching the process requirements.

It may be possible to change the system or process that a motor is driving to allow the motor to run at full load for shorter time periods, rather than operate continuously with a partial load. For example, consider a pumping system that maintains liquid levels in a large tank; the pump runs continuously and the flow into the tank is regulated by a control valve. It might be possible to remove the control valve and install level switches in the tank linked to simple on/off control, to switch the pump on when the levels drop to a predetermined threshold and off when the tank is full. This would maintain the required flow of liquid to the tank, but allow the pump to operate on full load at better efficiency for short periods. The same amount of useful work is being done, but the pump and motor are now operating at a higher efficiency and saving energy. Equally, where there are two or more pieces of equipment working in parallel, which are partially loaded, it may be possible to turn one of them off and maximise the performance of the other(s).

## System design and optimisation

All electric motor systems comprise component parts selected and connected together in order to perform the required function. Each of these parts has an optimum performance range and an operating point where its efficiency will be at a maximum. Ideally, all of the component parts will have been selected such that they are operating at their peak efficiency and the overall system is highly efficient. Unfortunately this rarely happens in practice. It is common to find 'contingency' where designers have allowed for additional capacity, or systems are not being operated at their original designed operating point. Typical examples include a production line where the throughput may have changed, or in a building where the desired ventilation rate has been increased.

Changing the operating point of a system may result in a complex interaction of the component parts and a rapid fall off in their efficiencies, resulting in very poor overall system efficiency. Evaluate the overall performance of the system and determine whether it is operating near its original design point, and near its best efficiency point. At the same time, the individual components should be assessed to determine how well they are performing. Where there are instances of poor energy performance there may be an opportunity to either adjust the throughput of the system, or evaluate components and replace them with alternatives that achieve a better match with the required conditions.

Examples of optimising systems include: selecting pumps or fans that are better suited to the duty

requirements; sizing pipe work or ducts to minimise flow velocities and associated friction losses; or changing pulley ratios on fans to better match their speed with the airflow requirement.

**Figure 5** illustrates the intersection of a pump characteristic curve with a system performance curve at different flow rates. The efficiency at operating point 1 exceeds the efficiency at operating point 2.

**Figure 5** Select components to ensure the system operates at its Best Efficiency Point (1)

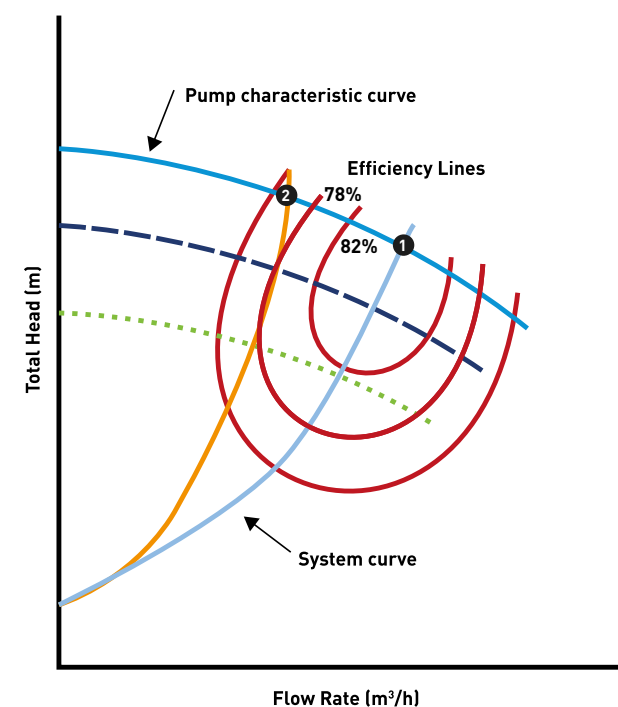

## Variable speed drives, integrated motor – drive units and soft starters

Improving the control of motor systems normally requires some capital investment but, in almost all suitable cases, the outlay is paid back within a short period of time through the savings generated.

### Variable speed drives (VSDs)

In applications where the motor is required to serve a variety of load conditions or has a continuously variable demand, an effective solution for reducing energy consumption is to adjust the speed of the motor to the process demands by equipping it with a VSD.

In addition to the energy saving opportunities, VSDs offer further benefits including:

- Improved process control (and hence output quality).
- The ability to control more than one motor.

VSDs are particularly beneficial in variable torque load applications (such as fans and pumps) where the output is controlled by other means such as inlet or outlet throttling, or damper adjustment. For example, savings of up to 50% of energy use are achievable by reducing the fan or pump motor speed by 20%.

VSDs are usually more expensive than simple motor controls, however, when applied correctly they can payback in less than two years in some applications.

VSDs can also be beneficial in constant torque load applications (such as screw or reciprocating compressors, conveyors, grinders, mills or mixers) where output varies. [See Variable speed drives technology guide \[CTG070\]](#).

In some variable load applications, especially where there are fixed transitions, operating two or more motors and equipment in parallel may be a suitable alternative to VSDs. In such applications, a sequencer will be used to automatically switch additional motors on and off according to the process demands. A typical example is the use of sequencers for multiple air compressors.

### Integrated motor – drive units

VSDs can be attached piggy-back style to a motor, in a combined package, and the market for these is growing. These are called integrated motor drives (IMD) but can sometimes be referred to as smart motors. IMDs have several advantages over separate units, including:

- Lower total cost.
- Reduced wiring time.
- No electromagnetic interference from the motor side inverter leads, cables or cabling.
- Optimum matching of the motor to the VSD.

IMDs are typically used in the pump market, where pump manufacturers can utilise the ability to reduce the speed of a pump, and therefore supply one package comprising pump, motor and drive.



**Figure 6** Motor pump combination with integrated VSD. Image courtesy of Grundfos.

## Soft starters

As described previously, a motor will draw a high current from the supply during starting. To reduce this starting current, it is possible to fit a soft starter device that limits the current to the motor during start-up, and achieves a smoother acceleration profile. This extends the life of the motor by reducing wear on the mechanical parts and prevents the electrical components from overheating. Consequently, the maximum number of starts and stops per hour may be increased. Often the life of the driven machine will also be extended due to the reduced acceleration stresses at start-up. Literature provided by motor suppliers will contain information describing the maximum permitted starts per hour.

## Case study

### What are other companies doing?

Hereford based Elite Plastics, is one of the UK's leading manufacturers of bespoke polythene films. Through the Green Business Fund, they have been able to save 19% on their £317,000 annual energy bill; this is in part thanks to the upgrade from old DC motors on the extrusion lines. In total they will cut their carbon footprint by 82.5 tonnes per year, and will have a payback period of only three years.

## Usage and housekeeping

### Ensure adequate cooling for motors and drives

A high proportion of energy losses associated with electric motors and VSDs occur in the form of heat. It is therefore important to keep VSDs and motors in dry, well-ventilated areas that are at suitable temperatures to allow for adequate cooling, or the equipment may be at risk of failure. A VSD can be attached directly to a motor, or located inside an enclosure some distance away; consider the location of the equipment carefully to ensure the cooling requirement is met and where dust cannot settle, or penetrate the VSD.

### Cables

Always choose the best quality cabling you can afford, Consult your VSD supplier on where best to locate the drive and suitable methods of connecting it to the motor.

### Clean components

It is important to keep motors clean, especially when they are located in dirty environments. Cooling fins on the motor body dissipate heat. If these are covered in dirt, it will reduce the contact the fins have with cooling air. A dirty cooling system therefore may run hot, use more energy and increase the risk of failure. To overcome this problem, put a motor-cleaning regime in place.

### Facts

Leaving 11kW of electric motors running over the weekends could cost over £4,000 each year.

## Motor system maintenance

There are different approaches to maintenance including Planned Preventive Maintenance (PPM) and Breakdown maintenance.

It is good practice to carry out planned preventive maintenance as this guarantees that maintenance is carried out regardless of whether a machine has broken down. It should be regarded a 'must' for all critical motor systems to achieve long-term reliability as well as energy efficient operation. Breakdown maintenance is reactive by nature and should only ever be regarded as a temporary 'quick-fix' solution, and is only suitable to non-process critical applications and where equipment running hours are low.

### Ensure the effective servicing of equipment

Always carry out maintenance in accordance with manufacturer's instructions. Servicing should include:

- Regular cleaning to make sure motors and associated equipment are kept free of dirt and debris.
- Checking the motor condition, making sure mountings are tight, and that there is adequate ventilation for cooling.
- Checking the alignment of motor and equipment shafts and pulleys.
- Checking the tension and condition of drive belts.
- An aural check. Listen to it – does it sound the same as normal?
- Visually checking for leaks from oil seals or damage to motors, gearboxes and related equipment.
- A suitable lubrication regime including greasing, oil top-up and oil replacement.

Motor manufacturers publish information on simple alignment checks that can be carried out using different tools including basic devices with straight edges. However, some of these can be time-consuming to use and rely on the installing engineer's subjective judgement. Therefore, larger sites may benefit from laser alignment, which is quicker to carry out and provides objective data to the engineer to allow the

motor/load to be accurately aligned first-time.

Most motors are supplied with sealed-for-life bearings requiring little maintenance. Specialist motors and other equipment may require lubrication and it is essential this is done properly.

Whilst using too little grease is bad practice, so too is over-greasing. Over-greasing can increase friction levels due to higher pressure within the bearing housing which causes burst seals, and results in bearing failure and higher energy consumption. Bearing manufacturers should be consulted for accurate information on how much grease to use and how often to apply it.

The type of lubrication used can also make a difference to the efficiency of the equipment. Always use the oil or grease recommended by the manufacturer.

### Belt maintenance

Depending on the type of belt, a properly maintained system will achieve transmission efficiencies between 94% and 98%, and will demonstrate good reliability. Industrial belt drives are often capable of operating for several years; however poor maintenance will result in a rapid drop in efficiency, especially on V belts where this could be 10% or more.

Losses in belt power transmission performance occur due to a number of reasons including:

- Misalignment: this reduces the belt drive

performance as well as its life due to increased wear and fatigue on the belt. It is one of the most common causes of premature belt failure. Extreme misalignment will destroy a belt within days or even hours. Misalignment can be either angular or parallel.

- Incorrectly tensioned belts: this may result in belts slipping and losing performance causing a reduction in life expectancy, and increased energy use. Unequally tensioned belts on multi-belt pulleys will result in excessive loading and reduced life on the tighter belts. Un-tensioned synchronous belts can jump teeth or ratchet, damaging the belt and leading to premature failure. Over-tensioned belts result in increased fatigue which will reduce belt life and also that of the bearings on the associated drive shafts.
- Excessive temperatures: in general, environmental

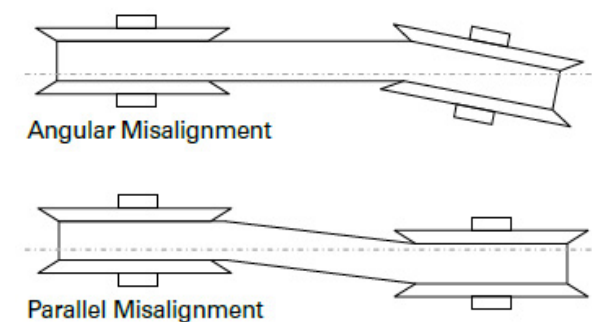

Figure 7 Types of pulley misalignment

temperatures for properly maintained V belts should be kept below 80°C, and below 85°C for synchronous belts. High temperatures cause belts to harden and develop cracks from the bottom of the belt upwards. An internal temperature increase of 10°C may reduce the belt life by half. Consult your supplier for belt specific guidance.

- Belt and pulley wear: this is especially important for V belts. Worn belts or pulleys will result in the belts not locating properly in the pulley leading to increased slip and wear.
- Oil or grease: the rubber material in belts in contact with these materials will swell and distort also leading to premature belt failure.
- Wear on guards: guard areas can sometimes come into contact with the belt leading to wear which can be easily overlooked especially on the inside. Dust or debris accumulated on the guard can act as an insulator leading to increased temperatures.
- Loose drive components: these can result in poor alignment and reduce drive belt performance.

Check equipment maintenance requirements against the actual maintenance carried out, and devise an appropriate maintenance schedule in accordance with the manufacturer's requirements. Thorough, regular maintenance will lead to increased system reliability in addition to energy savings.

See [Motor and drives maintenance checklist \[CTL154\]](#) for additional information.

### Top tip:

Check shaft alignment. Even a small misalignment will reduce system efficiency by several per cent – costing money.



# Opportunities for energy savings with motors

There are many different types of motor but in every case and application using them efficiently can lead to savings.

## Did you know?

The International Electrotechnical Commission (IEC) motor efficiency classification standard IEC60034-30 was introduced in 2008, and then updated in 2014 with the new standard, IEC 60034-30-1. This gives users a simple indication of the efficiency of a motor, ranked by a 43-class system.

## Regulations affecting motor efficiency and the market

### Motor efficiency labelling standards

Motor efficiencies vary, being influenced by the design of the motor and the materials from which they are constructed.

From 2001 to 2010, motors in the UK were classified according to the European (CEMEP) motor efficiency

classification scheme comprising the classes, Eff1 (high efficiency), Eff2 (standard efficiency) and Eff3 (lower efficiency), with between 3% and 4% difference between each grade.

Motor efficiencies have continued to improve and in 2008 the International Electrotechnical Commission (IEC) motor efficiency classification standard was introduced. This classifies motor efficiency according to the labels IE1, IE2, IE3, IE4, and the recently introduced IE5, where IE5 is the most efficient. The standard now includes 8-pole motors, and an extended power range. The efficiency standards still apply to any single or three phases line motor (regardless of technology) operating at 50 or 60Hz.

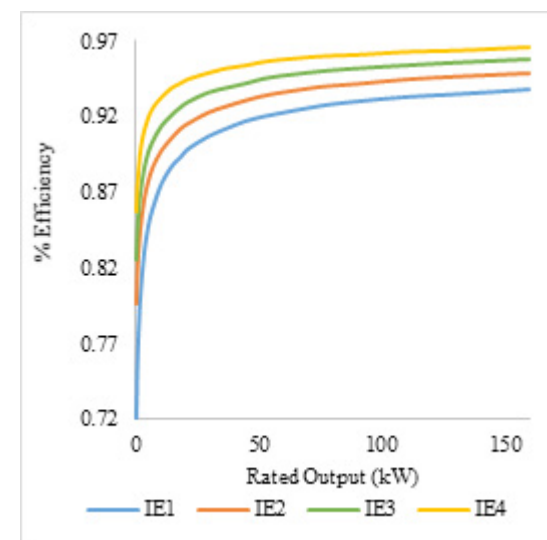

Figure 8 Illustrates the IE3 to IE4 efficiency bands for 4 pole motors, as defined in the IEC standard.

## Mandatory minimum efficiency requirements

In 2009 the European Commission announced new mandatory minimum efficiency requirements for AC induction motors being placed on the market or put into service, according to the following stages:

<b>Stage 1</b> From 16 June 2011	Motors must meet the IE2 efficiency level.
6th January 2014	IE4 efficiency level introduced but no obligation to upgrade to this level.
<b>Stage 2</b> From 1 January 2015	Motors with a rated output of 7.5kW – 375kW must meet EITHER the IE3 efficiency level OR the IE2 level and be equipped with a variable speed drive.
<b>Stage 3</b> From 1 January 2017	Motors with a rated output of 0.75kW – 375kW must meet EITHER the IE3 efficiency level OR the IE2 level and be equipped with a variable speed drive.

Manufacturers are required to make available in their literature information describing the efficiency 'IE' class and the actual efficiency of their motors.

Whilst the majority of motors will be compliant with these requirements, some are exempt, such as those designed for operation in potentially explosive atmospheres. Purchasers are advised to seek clarification from their suppliers when discussing purchasing options.

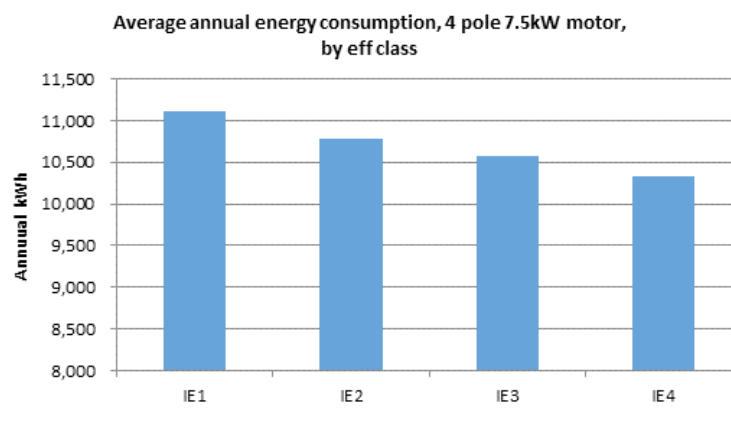

Figure 9 Broad comparison of motor efficiency

## Safety first!

Be careful when dealing with motors that operate in hazardous atmospheres. If you have motors operating in this environment, they may not be appropriate for the energy saving advice given in this overview. Check with the manufacturer before making any changes.



## Energy saving opportunities

### Higher efficiency motors (HEMs)

Replacing motors with higher efficiency versions saves energy. HEMs may cost more, but use between 2% and 5% less energy and so they should always be considered in purchasing decisions. The best in class motors also qualify for 100% tax relief under the Enhanced Capital Allowance scheme. See [page 36](#) for further information.

#### Fact:

An 11kW higher efficiency IE4 motor in continuous use will use almost £1,000 less energy per year than a lower efficiency IE1 motor.

### Permanent magnet and other high efficiency motors

It is becoming increasingly difficult to achieve further efficiency gains with conventional AC induction motors. To achieve the IE4 performance levels and beyond, some manufacturers are adapting technologies traditionally used in specialist applications including permanent magnet and reluctance motors for use in their mainstream products.

Hybrid induction motors using permanent magnets are available as direct replacements for single speed AC induction motors. Other permanent magnet motor designs and reluctance motors are available however these require electronic controllers (variants of VSD) in order to operate. As such, these solutions can act as direct replacements for AC induction motors equipped with VSDs.

EC (electronically commutated) motors are brushless DC permanent magnet motors which use specialist electronics to control the supplied current to provide accurate motor control. These can be connected directly to an AC supply and can be around 30% more efficient than AC induction motors.

In addition to increased energy efficiency, the other advantages of permanent magnet and reluctance designs include:

- a higher power density resulting in smaller motors (frame size).
- a wider speed range.
- increased starting torque.

These benefits are starting to allow system designers to review the way certain systems are designed. For example, in some applications the use of a gearbox can be eliminated, realising cost, space and additional energy savings.

### Rewind or replace?

In most cases it is more cost-effective to replace a failed motor with an HEM, rather than repair it. This is because the relative cost to rewind motors, especially smaller motors, can be high and rewinding a motor may reduce its efficiency. The cost benefit of an HEM replacement will vary according to the motor size and its operating hours.

Refer to section “Rewind or replace?” on [page 25](#) for further information on rewind versus repair decision making.

Replacing a failed motor with an HEM can save more money over time than having it repaired.

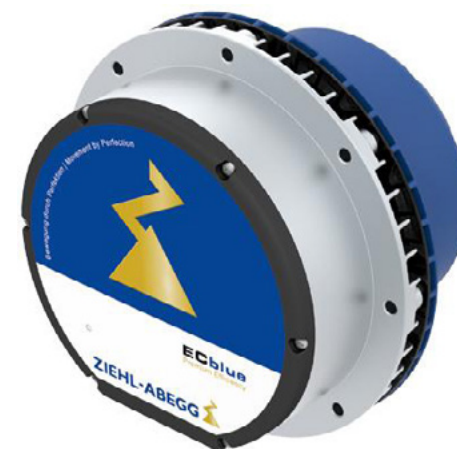

Figure 15 EC motor. Image courtesy of Ziehl-Abegg.

## Electrical power quality

### Rectify voltage unbalance

Motors powered from three-phase electrical supplies require a balanced voltage in order to operate efficiently. Unbalanced voltages are a primary cause of motor overheating and premature failure, as well as reducing overall energy efficiency.

In a three-phase system, the voltage unbalance is defined as: 100 times the absolute value of the maximum deviation of the line voltage from the average voltage on the three phases, divided by the average voltage.

For example, in a 400 volt system, if the measured line voltages are 405 volts, 408 volts, and 390 volts, then the average is 401 volts, and the unbalance is:

$$100 \times (401 - 390)/401 = 2.74\%$$

An imbalance of 3.5% in the supply voltage can decrease motor efficiency by up to 2%. Check the supply voltage to the motor and where the imbalance exceeds 1% carry out corrective reallocation of single phase loads at the site to restore the balance.

### Motor sizing and loading

The 'loading' (or load factor) of a motor is the amount of work it does compared with its maximum rated power output. For example, a motor rated at 90kW driving an 81kW load is said to be 90% loaded. Modern motors operate most efficiently above 50% loading with a peak between 75% and 90% load.

Note that the rating plate on a motor declares its output power at the shaft, so the actual electrical input energy drawn will be the output power at the shaft plus the power lost due to the motor inefficiency. So, in the example above where the 90kW motor is, say, 95% efficient, then with an 81kW load it will actually draw about 85.3kW from the mains supply.

This is calculated as:

$$\text{kW drawn} = (\text{Rated kW} \times \text{loading})/\text{efficiency}$$

### Avoid light loading on motors

Sometimes motor under-loading is unavoidable. Operating a motor with a load below 40% of its rated capacity is likely to result in some loss of efficiency. For efficient operation a motor should be loaded from 50% of its rated capacity or higher.

If a system is such that high loading cannot be achieved, there are ways in which the efficiency of a partially loaded motor can be improved:

- **Review motor sizing:** In some cases it may be possible to replace the larger partially loaded motor with a smaller and higher efficiency class motor running at a higher loading, for example a 7.5kW IE1 motor with efficiency 86.0% is replaced with a 5.5kW IE3 motor with efficiency 89.6%. As smaller motors tend to be less efficient than large motors, careful analysis of the loading and relative efficiencies of the motors will have to be carried out to determine viability of this option. Scenarios where this option is likely to be viable include motors loaded at 40% or less. One way to find out if a motor is correctly sized is to compare the details on the rating plate with the actual rating

required by the equipment it is driving. For a more accurate measure, monitor the electrical power consumption of the motor using a suitable power meter or energy logging device. Once information on the running is recorded, obtain a graph of motor efficiency curves (available from the motor manufacturer) to find out how efficient the motor is at a particular loading. Be sure to check the starting torque of the intended replacement motor and ensure this is sufficient for the load.

- **Fit motor optimisers:** Some applications require large motors in order to overcome significant short term loads such as the starting torque on certain refrigeration compressors, or cyclical loads in some stamping or pressing processes. In these circumstances the high loading may last only a small per cent of the overall operating time, and for the remainder of the cycle the motor is operating with a light load.

In such applications, and where it is impractical to swap the motor or change the method of operation, it may be worth considering motor optimisers. These products, sometimes called 'motor controllers' or 'power factor controllers', dynamically monitor the load on the motor. When lightly loaded they use solid state devices to reduce the average voltage supplied to the motor resulting in a reduction of the so called 'iron losses'. Energy savings during the periods when the motor is lightly loaded are possible and these will be in the region of 1% to 3%. Iron losses are greater in low efficiency motors and so an optimiser will be better suited to these. Take specialist advice on this approach before proceeding to implement any solutions.

# Opportunities for energy savings with transmissions

## Use the correct transmission system

Transmission systems are the mechanisms or devices transferring the rotary motion of the motor shaft to the equipment using the motive power.

The most common forms of transmission are:

### Direct drive

This is where the load is connected directly to the motor shaft with a simple in-line coupling device. This is the simplest, and most energy efficient transmission method and requires little maintenance. For this method to be suitable, the load must rotate at the same speed as the motor and there should be no space restrictions. Direct drives require the motor to be placed in line with the load, whereas with a pulley or gearbox system the motor can be orientated differently.

### Belt-driven pulley

Here the motor is coupled to the load via pulley wheels fitted with one or more drive belts.

This tends to be used where it is not possible to directly couple the motor to the load due to space restrictions, or where a speed (and torque) adjustment is required by fitting different sized pulley wheels on the motor and the load.

Unlike chain and gear drives, belt drives run smoothly and emit little noise as they can isolate vibrations and most require no lubrication.

Belt systems vary in efficiency according to type and condition. V belts are the most commonly used with efficiencies ranging between 93% and 98%, however, their performance deteriorates by about 4% with age, and/or with poor maintenance by about a further 5-10%. Wedge or cogged wedge belts can maintain efficiencies around 2% higher than standard V belts. Synchronous, flat and ribbed belts can attain

efficiencies between 96% and 99% and require less maintenance. Recent developments have led to wider application possibilities for synchronous, flat and ribbed belts and it is worth investigating changing from V belt systems to these where practical.

Figure 10 Belt types

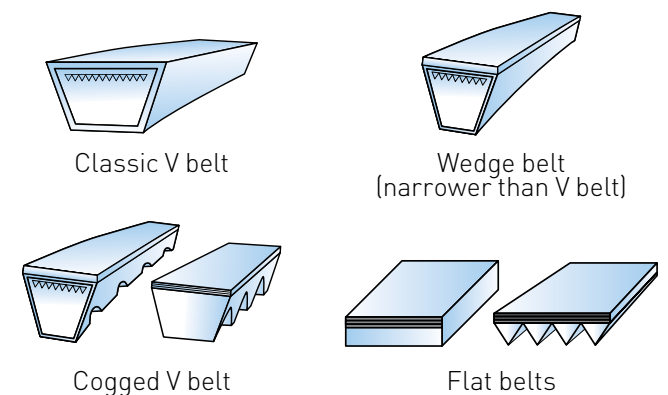

## Gearbox

In a gearbox the motor output speed (and torque) is adjusted using a series of gears located in a housing with input and output shafts. The speed change between the input to the gearbox and the output is defined in terms of the gearbox ratio, for example: 2,000rpm changed to 1,000rpm is a 2:1 ratio. The type of gear used varies depending on the application and each type will have a different efficiency. Therefore, it is important to ensure that the correct type is selected for the application. For example, a worm gearbox, which can deliver very high torque, typically has an efficiency of 85-90% compared with 98-98.5% for a new helical gearbox, which might deliver lower torque.

To lower the speed of the output, it may be possible to replace the gearbox for one with a higher ratio. Increasing the ratio may decrease the efficiency of the gearbox, however, this needs to be weighed against the potential energy savings that may be realised in the system.

A consultant or supplier will be best-placed to advise on savings with specific gears. The illustration to the right may help to identify the gears that are used.

### Identify your gears

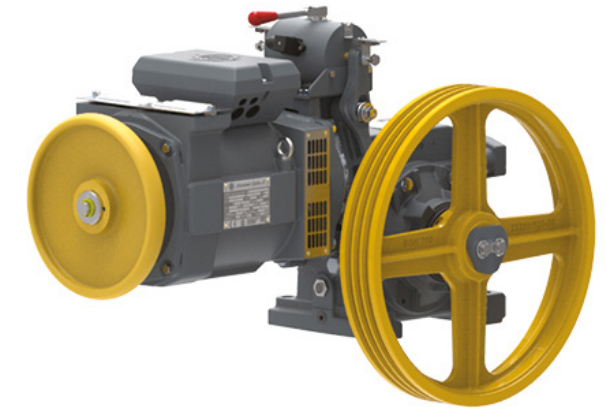
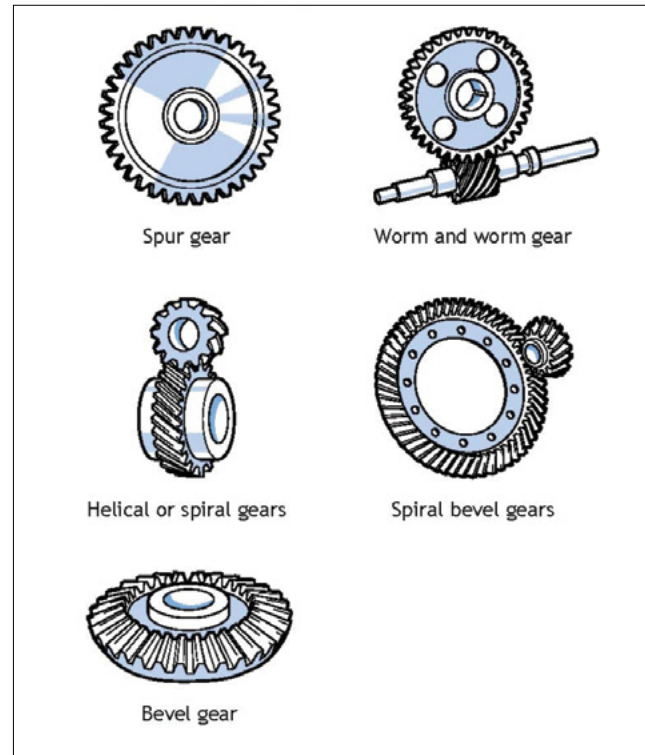

*Image courtesy of Ziehl-Abegg*

**Figure 11** Motor – gearbox combination

# New equipment

Buying new equipment is a great opportunity to improve energy performance.

Replacing a motor or drive is not always straightforward, but time spent correctly specifying and considering the efficiency of the whole system pays dividends.

## Specifying new motor-driven and drive systems

Using the information provided in this overview, produce a policy for your organisation that ensures energy saving is considered as part of the decision to purchase motors and related equipment, and that purchasing specifications are updated. The following steps may be considered when specifying and purchasing motor equipment. These might form the basis of a motor management policy, discussed later in this publication (see [page 24](#)).

### Minimise the demand

Before any specification begins, consider the opportunity to minimise the demand as described in section [“Minimising demand and process optimising”](#).

### Size the equipment correctly

As described in section [“System design and optimisation”](#), always make sure the motor and related equipment are correctly dimensioned to match the system and process requirements. Equipment designers often add 10% safety margin, and then specifying engineers often add another 10% for safe. The combined effect of these can result in low efficiency and wasted energy.

Specifying components that suit the current inefficiencies will limit the potential energy savings of the system. Improvement measures could include actions such as trimming the impeller of a pump or changing to a lower ratio gearbox.



Integrated motor and pump. Image courtesy of Grundfos

### Consider the most efficient option

For each part of the system, consider all the options to make savings. Ask if any of these would be appropriate:

- VSDs.
- High Efficiency Motors.
- Automatic controls/sequencers.
- Soft starters.
- Improved transmission systems.
- Higher efficiency driven equipment (pumps, fans etc).
- Size pipe work and ducting to minimise velocities and associated friction losses.

### Life cycle costing

The choice of the motor and related equipment should depend not just on the initial purchase cost, but on other considerations such as the full life cycle cost of the equipment. The life cycle cost is the capital price (purchase and installation), plus maintenance and running costs (based on energy prices) over its life time. Whilst a new higher efficiency motor may cost more to purchase than having an old one rewound, life cycle cost calculations may show that the overall cost to own and operate it over a predetermined timeframe is significantly less.

#### Worked example: Life costing a motor

A simple life costing of a motor can be calculated using the following formulae:

**Life Cost = Capital cost + (n x Annual running cost)**

and

**Annual running cost = (kW/eff) x L x hrs x £<sub>elec</sub>**

Where:

**n** = time frame in years over which the payback is assessed

**kW** = rated kW of the motor

**L** = typical loading (how hard the motor is working in relation to its rated kW), use 0.75 as a default

**hrs** = annual operating hours

**£<sub>elec</sub>** = cost of electricity (£/kWh)

**eff** = efficiency of the motor (%)

So, an 11kW IE4 motor (which is at least 93.34% efficient) running for 4,000 hours a year at 75% load consumes:

$$11/93.3\% \times 75\% \times 4,000 = 35,370 \text{ kWh/year}$$

With an electricity cost of 12p/kWh, this would cost £4,240/year

The same system running an IE1 (approx. 87.6% efficiency) motor which has been rewound once (losing 2% efficiency and now at 85.6%) would consume:

$$11/85.6\% \times 75\% \times 4,000 = 38,551 \text{ kWh/year}$$

With the same electricity unit cost, this would be £4,630/year

If the cost to rewind the IE1 motor is £430 and the cost to purchase a new IE4 motor is £1,300, and assuming that both motors have a life of 10 years, the overall life costs are:

Rewound IE1 = £46,730

New IE4 = £43,700

Assuming similar amounts for installation and disposal costs, purchasing a new IE4 motor makes a saving of £3,030 over the motor's lifetime. If the run hours or loading on the motor were to change, then the saving potential will vary accordingly.

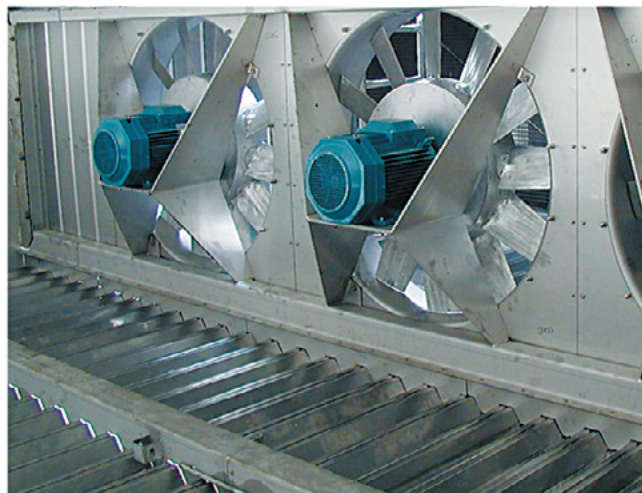

"Motors with axial fans in ventilation system"  
Supplied courtesy of Siemens

## Green Business Fund

Investing in energy efficient equipment makes sound business and environmental sense, especially with the help of the Green Business Fund, which provides a combination of advice, training and direct capital contribution for eligible energy saving equipment. To find out more visit: <http://www.carbontrust.com/greenbusinessfund>

## Tax incentives

Accelerated tax relief is available for businesses purchasing energy efficient equipment from the Energy Technology List (ETL) using the Enhanced Capital Allowance (ECA) scheme. All of the tax relief may be claimed in the year of purchase if the product is listed on the ETL at the time of purchase. Motors and drives is a technology category on the ETL.

The procedure for claiming an ECA is the same as for any capital allowance. For further information please visit <https://www.gov.uk/guidance/energy-technology-list>, where eligible energy efficient products can be viewed, or call the Carbon Trust on [0300 330 0657](tel:03003300657).

# Motor management policies

## Introduce a motor management policy

A motor management policy (MMP) will provide a structured approach to the repair and maintenance of motors, realise notable cost savings on most motors in an organisation, and achieve other benefits such as reduced downtime.

Consider preparing an MMP using the information given in this overview. The MMP should include the following:

- A schedule and procedure for motor maintenance.
- A plan for purchasing new and more efficient motors.
- A plan for repairing failed motors, which includes making the comparison between repair costs and purchasing new motors using whole life cycle costs.
- A method for tracking the number of times motors have been rewound.

## For any MMP scheme to be successful it must have:

- Commitment from senior management.
- Clearly defined responsibilities.
- Sufficient resources for both planning and implementation.
- Built-in review periods to account for changes in prices of motors or electricity, or new products available on the market.
- Planned dissemination routes so that those who need to know are aware of the key points.

## The preparation of an MMP should also mean that:

- There is no need to prepare a separate case for each purchase decision and time is not wasted repeating detailed calculations.
- All levels in the company can be given the relevant authority to influence equipment purchases.
- The policy demonstrates the company's commitment to energy efficiency to stakeholders, and encourages further energy saving actions.



## Rewind or replace?

The efficiency loss due to rewinding a failed motor will vary according to the motor type and the processes used during the repair; it can be assumed that in most cases, a failed motor that has been rewound will be 0.5%-2% less efficient than it was previously. Although the cost of a rewind may be less than buying a new replacement, especially for larger motors the reduction in energy efficiency will mean that the increased running costs could quickly exceed the initial saving.

The decision on whether to rewind or replace motors should be based on lifecycle costs and linked to motor rewind prices versus replacement prices, annual running hours and electricity prices. Generally, the larger the motor, the more likely for it to be economic to repair, and so the decision to repair or replace can be reduced to a consideration based on motor size and annual running hours.

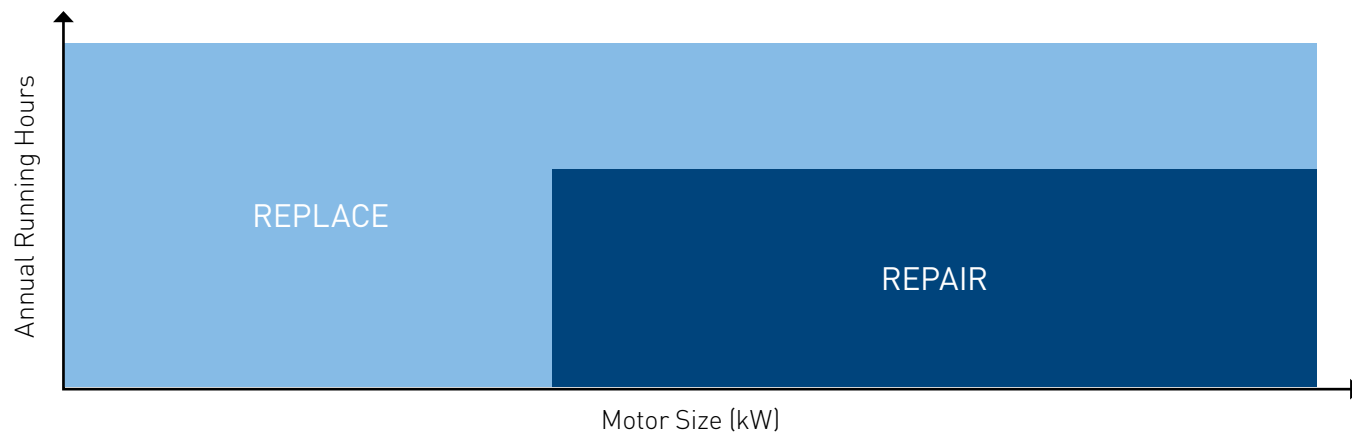

Figure 12 *Rewind vs. Replace*

The MMP should have guidance on this issue and this will be tailored to the local circumstances. Broadly speaking, the cost difference between repairing and replacing a smaller motor (typically below 5.5kW to 11kW) is so small that replacement should be the automatic choice, irrespective of running hours. Conversely, for larger motors, repair is usually more economic, depending on the running hours. In between there is a 'grey area' which usually requires some thought or calculation before the right choice can be made.

However, some general rules could be applied such as:

- If a motor is below 5.5kW, the motor should be replaced automatically rather than repaired.
- HEMs should be the preferred replacement.

- If it is a higher efficiency motor (HEM) then it may be repaired.
- A motor should not be rewound more than twice, unless there are exceptional circumstances.
- If very badly damaged the motor should be replaced.
- Where the above rules cannot be complied with, and a motor is needed urgently, then a special case shall be made to justify the remedial action.

# Monitoring

Without a method for detecting wastage, long-term energy savings are more difficult to achieve. In addition, measuring the performance of equipment will allow the success of energy saving initiatives to be assessed.

Monitoring is an effective method of tracking and understanding the energy performance of equipment and systems; it may be used to:

- Inform immediate no-cost or low-cost energy saving solutions that can be made.
- Identify less obvious savings opportunities.
- Highlight potential issues by analysis of trends, such as imminent malfunction or where equipment is deviating from original performance levels.

For many of the simpler energy saving opportunities, detailed monitoring may not be necessary. However as systems get larger, or where opportunities may not be so easily identified, taking measurements and detailed monitoring become increasingly important.

The costs associated with taking measurements and monitoring varies according to the type of measurements and equipment used. Low cost and temporary monitoring should be applied to smaller systems where the savings potential is unlikely to be significant, whereas large systems might benefit from permanent automatic monitoring systems that will identify variations and problems in real time.

## Carrying out measurements

Take measurements of the electrical power consumed by the motors to develop an understanding of the systems and their energy use.

This information will help determine which actions could produce worthwhile savings. Measurements should also be taken after energy saving activities have been implemented to confirm the savings actually made. This could be used for reporting to management or staff, or to justify future spend.

Equipment for carrying out measurements includes:

- **Hours-run meters:** These provide information on the time the equipment has been running. Often, just knowing more about the equipment's operation can lead to energy saving ideas, for example, knowing whether the equipment has been running longer than necessary.
- **Portable energy loggers:** These devices may be temporarily connected to a motor's electrical supply; they provide an accurate picture of power consumption and motor loading both instantly and over a given time period. They should be used where larger capital investment is proposed and more comprehensive data, describing energy consumption over a pre-defined time period is therefore required. Some energy loggers also provide an indication of electrical parameters such as voltage and current per phase, and power factor, all of which are useful in assessing a motor's performance.
- **Permanent kWh metering:** kWh meters installed as sub meters are particularly suited to larger motors where they provide an ongoing picture of the energy being consumed. Such meters should be read on a regular basis to enable usage trends to be identified. Larger sites may wish to automate this data collection and reporting process using one of the many different automatic monitoring and targeting systems available.

## Condition monitoring and analysis

Condition monitoring and analysis techniques that look to predict the failure risk of mechanical components can also be used to inform energy consumption trends. They tend to be used at sites with large equipment or sites where breakdown is a critical issue.

Condition monitoring techniques include:

- **Vibration analysis:** This is where equipment is analysed for noise and vibration. A vibration-sensing probe is attached to the motor, gearbox or related equipment and a frequency logger records vibration levels at different frequencies. Graphs presenting a breakdown of the vibrations can then be analysed and diagnosed to identify potential bearing failure, shaft alignment discrepancies, lubrication problems and similar issues.
- **Oil analysis:** This is where gearbox oil samples are analysed to identify wear, or contamination issues.
- **Thermographic surveys:** Heat-sensing cameras can be used to identify overheating issues as well as electrical faults.



Supplied courtesy of ABB

Figure 13 Carry out monitoring of motor equipment

## Your next steps

The following steps suggest a methodology to assess the condition and energy performance of your systems, and identify where you can improve efficiency.

Considerable savings can be made by taking action in-house. However, other options may need specialist support from a supplier or consultant.

### Step 1: Compile an inventory of your motor systems

Inventories provide a framework to track motors and equipment and record performance information. Look at each process or system and identify where motors are situated, recording them on the motor/drive inventory.

The information stored in the inventory will be relevant to the site and the relative importance of each motor. Generally the larger the motor, or the more critical it is to site operations, the more data should be collected.

An example page from a motor inventory is shown on [page 29](#).

### Step 2: Prioritise motor systems for initial investigation

Higher priorities are usually linked with the biggest energy users. A simple method of gauging motor energy use is to multiply motor size by annual running hours. A smaller motor running long hours can use more energy than a larger motor running few hours.

Look at support equipment; in many processes the primary equipment may be performing a precise function where it is difficult to introduce energy saving opportunities without causing adverse impacts, whereas support equipment may be more easily improved.

Carry out steps 3 to 6 on each system.

Site Details & Motor Reference	Site	Central
	Motor ref	C/W2/M367
	Application	Pump
	Location	Warehouse 2
Name plate details	Manufacturer	A.N. OTHER
	Rated power	7.5kW
	Speed	1,450 RPM
	Efficiency Class	<IE1
	Power factor	0.83
	Full load current	14.85 AMP
	Serial number	
Equipment details	Description of equipment	Cooling water supply pump for warehouse.
	Control Method	Manual ON – OFF. Output regulated by throttle.
	Notes on motor duty	Motor running 24 hours a day at an estimated 2/3 load, but actual water demand varies greatly.
	Repair history	
	Installed	Nov 1985
	Rewound	Aug 1994
	Rewound	July 2003
Actions	Replace with HEM at next failure. Investigate opportunity to fit a VSD.	

### Step 3: Determine the overall process demands

Develop an understanding of the demands of the overall process that the motor is serving. Look for opportunities to reduce the process demands, for example by reducing set points.

### Step 4: Review the service the motor system is delivering

Determine whether the motor system: a) is necessary, b) could be delivered by other more efficient means, and c) throughput closely matches the process demands.

### Step 5: Look for opportunities to optimise the motor system

Using the suggestions presented in this guide review the throughput of the system and look for ways to ensure it is working near its peak efficiency. Examine the performance of the whole motor system and of the individual components, ensure they are operating near their best efficiency.

Figure 14 Sample entry from a motor inventory

### Step 6: Look for opportunities to improve the control of the motor system

Examine the way in which the motors and drives are used. Think about issues such as the control methodology, switching off, variable speed control, reducing speed, loading, and mechanical power transmissions. Try to ensure the motor system throughput closely tracks the demands of the process it is serving. Review existing controls and determine whether they are actually doing what they were intended to.

### Step 7: Compile a list of energy saving opportunities and prioritise your actions

Your investigations could reveal a range of actions for saving energy. Some measures could be simple to implement in-house, whilst others may require specialist assistance.

To help inform your decisions:

- Take measurements and monitor equipment power consumption, relate this to throughput or useful work done and set energy performance benchmarks.
- Gather information. Speak with plant operators and maintenance staff, and review maintenance records. Usually they will provide insight that may not be obtained elsewhere.

- Investigate problem systems. In many cases where equipment is not operating correctly the energy performance is likely to be poor.

### Step 8: Seek specialist help, make the changes and measure the savings

Once you have discussed the more complex or expensive options with a specialist you should put in place the energy saving actions. Ensure that you are measuring the savings realised as these will provide useful information that will assist future management decisions about motor/drive systems.

### Step 9: Develop your motor management policy

A MMP provides a structured approach to decisions made for motors. It may take some time to complete the policy and you will need the information collected in Step 1 to help inform this. The number of repairs that a motor has undergone may be recorded and this will facilitate decisions to be made regarding whether a motor should be repaired or replaced. Reference can then be made to the motor management policy (MMP) to help inform that decision.

### Step 10: Continue to manage systems for energy efficiency

Put in place policies, systems and procedures to ensure that systems operate efficiently and that savings are maintained in the future. Regular monitoring of electrical energy consumption and comparison against productivity benchmarks will help to rapidly identify when motor system performance is deviating.

---

## Go online for more information

The Carbon Trust provides a range of tools, services and information to help you implement energy and carbon saving measures, no matter what your level of experience.

---

**Website** – Visit us at [www.carbontrust.com](http://www.carbontrust.com) for our full range of advice and services.

➤ [www.carbontrust.com](http://www.carbontrust.com)

---

**Tools, guides and reports** – We have a library of publications detailing energy saving techniques for a range of sectors and technologies.

➤ [www.carbontrust.com/resources](http://www.carbontrust.com/resources)

---

**Events and workshops** – We offer a variety of events, workshops and webinars ranging from a high level introductions to our services through, to technical energy efficiency training.

➤ [www.carbontrust.com/events](http://www.carbontrust.com/events)

---

**Small Business Support** – We have collated all of our small business support in one place on our website.

➤ [www.carbontrust.com/small-to-medium-enterprises](http://www.carbontrust.com/small-to-medium-enterprises)

---

**Our client case studies** – Our case studies show that it's often easier and less expensive than you might think to bring about real change.

➤ [www.carbontrust.com/our-clients](http://www.carbontrust.com/our-clients)

---

**The Carbon Trust Green Business Fund** – is an energy efficiency support service for small and medium-sized companies in England, Wales and Scotland. It provides direct funded support through energy assessments, training workshops, and equipment procurement support.

➤ [www.carbontrust.com/client-services/programmes/green-business-fund](http://www.carbontrust.com/client-services/programmes/green-business-fund)

---

**SME Network** - Join a community of over 2000 small and medium-sized businesses to discuss your strategy and challenges to reducing carbon emissions and improving resource efficiency. Sign up for free to share knowledge, exchange useful resources and find out about the support and funding available in your area, including the details of your local energy efficiency workshops.

➤ [www.carbontrust.com/resources/tools/sme-carbon-network](http://www.carbontrust.com/resources/tools/sme-carbon-network)

The Carbon Trust is an independent company with a mission to accelerate the move to a sustainable, low-carbon economy. The Carbon Trust:

- advises businesses, governments and the public sector on opportunities in a sustainable, low-carbon world;
- measures and certifies the environmental footprint of organisations, products and services;
- helps develop and deploy low-carbon technologies and solutions, from energy efficiency to renewable power

[www.carbontrust.com](http://www.carbontrust.com)

+44 (0) 20 7170 7000

The update of this publication has been funded through the Carbon Trust Green Business Fund, an energy efficiency support service for small and medium-sized companies in England, Wales and Scotland.

Whilst reasonable steps have been taken to ensure that the information contained within this publication is correct, the Carbon Trust, its agents, contractors and sub-contractors give no warranty and make no representation as to its accuracy and accept no liability for any errors or omissions. All trademarks, service marks and logos in this publication, and copyright in it, are the property of the Carbon Trust (or its licensors). Nothing in this publication shall be construed as granting any licence or right to use or reproduce any of the trademarks, service marks, logos, copyright or any proprietary information in any way without the Carbon Trust's prior written permission. The Carbon Trust enforces infringements of its intellectual property rights to the fullest extent permitted by law. The Carbon Trust is a company limited by guarantee and registered in England and Wales under company number 4190230 with its registered office at 4th Floor, Dorset House, 27-45 Stamford Street, London SE1 9NT, UK.

Published in the UK: May 2018. CTV048v3

