

Variable refrigerant flow (VRF) systems



Ir. Dr. Sam C. M. Hui

Faculty of Science and Technology

E-mail: cmhui@vtc.edu.hk

Contents

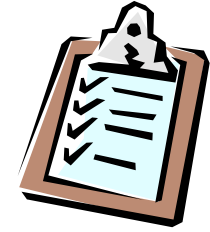

- System Overview
- Components and Types
- System Operation
- Design Issues



System Overview

- Variable refrigerant flow (VRF) systems*
 - Direct expansion (DX), similar to **multi-split** systems; widely used in Japan and Europe
 - Able to control the amount of **refrigerant** flowing to the **multiple evaporators** (indoor units), enabling the use of many evaporators of differing capacities and configurations connected to a single condensing unit
 - Provides an **individualized** comfort control, and **simultaneous cooling & heating** in different zones

An example of variable refrigerant flow (VRF) system

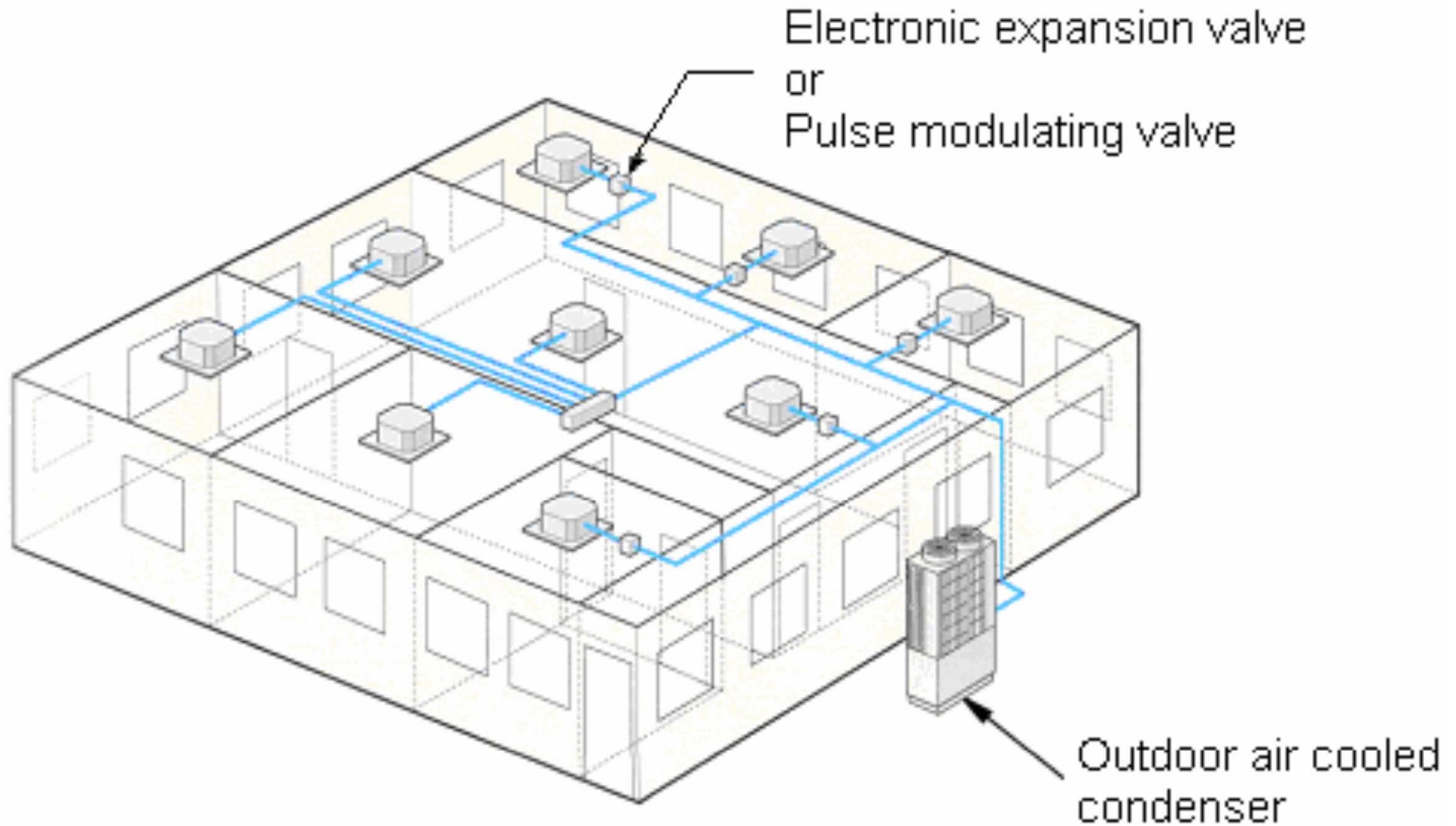

VRF System with Multiple Indoor Evaporator Units

(Source: Fujitsu)

VRF system with simultaneous cooling & heating (by heat recovery)

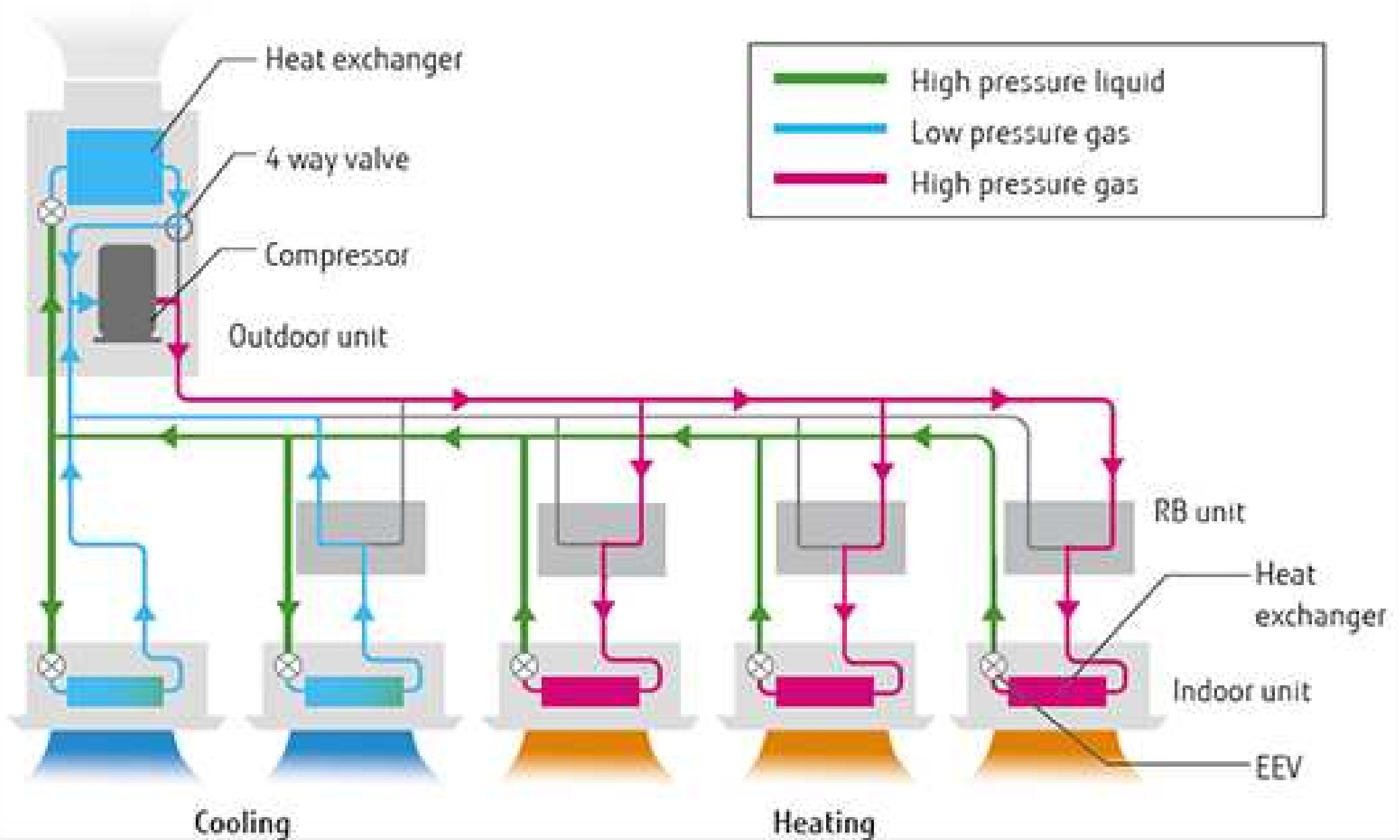



System Overview

- VRF systems:
 - Similar to unitary and other common DX systems, and share many of the same components (i.e., compressor, expansion device, heat exchangers)
 - Highly engineered, with single or multiple compressors, multiple indoor units (ducted and non-ducted types), and oil and refrigerant management and control components
 - Typical capacities: 5.3 to 223 kW for outdoor units and 1.5 to 35 kW for indoor units

History of variable refrigerant flow (VRF) system

• VRF world first's

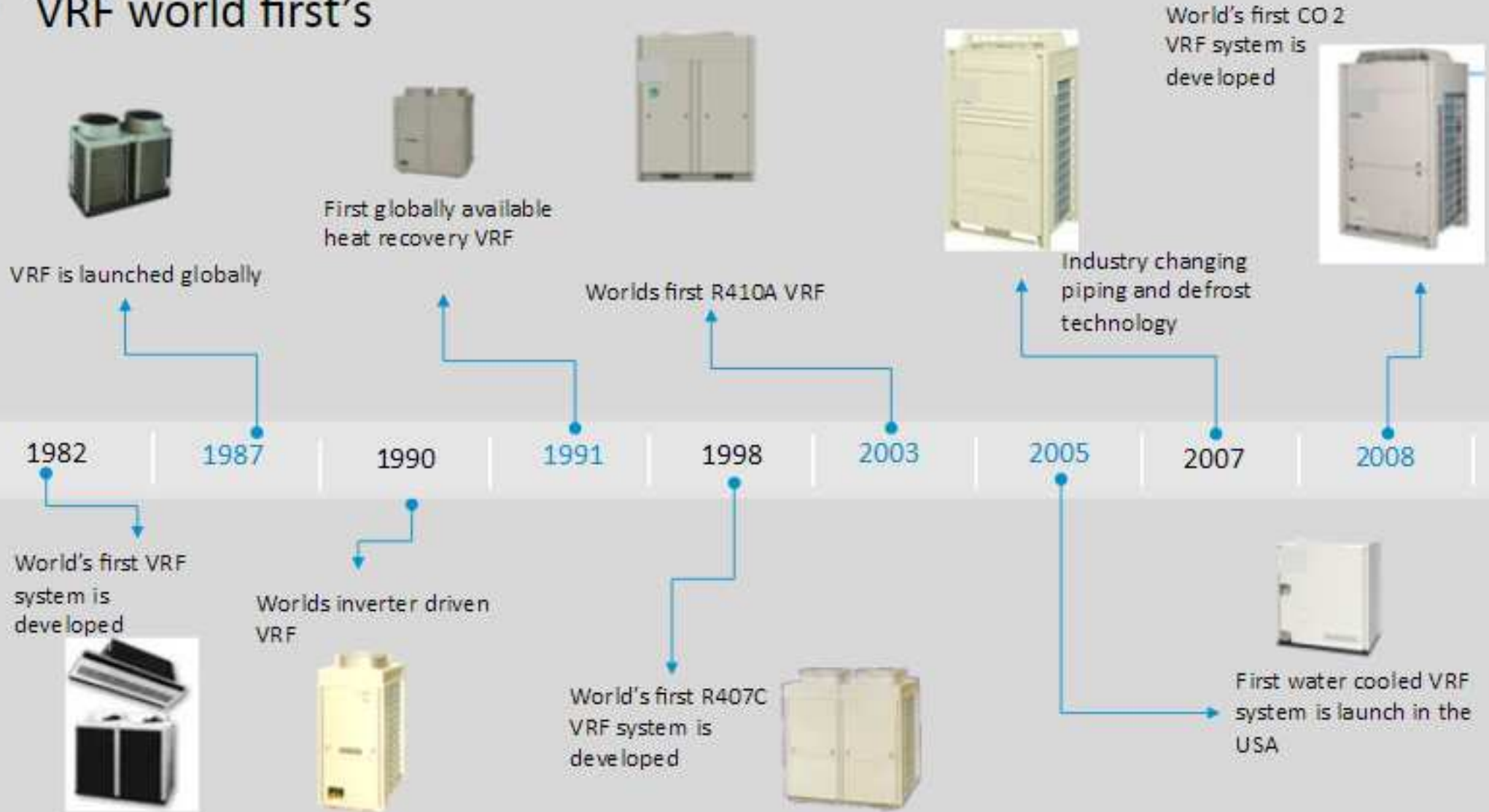

Traditional HVAC systems:
- Chiller/central plant
- Split and package systems

Do you know the difference with VRF?

Comparing chiller/central plant with VRF system

Chiller

Complicated

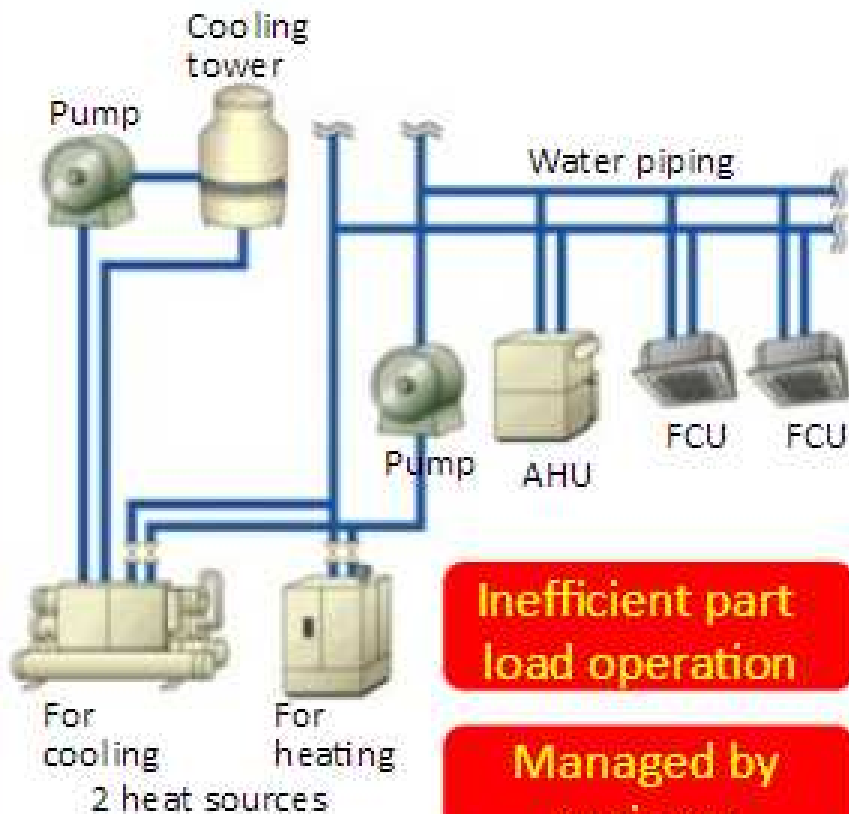

Inefficient part load operation

Managed by engineer

VRF

Simple system

Energy efficient

Space-conscious design

Outdoor unit



Refrigerant piping

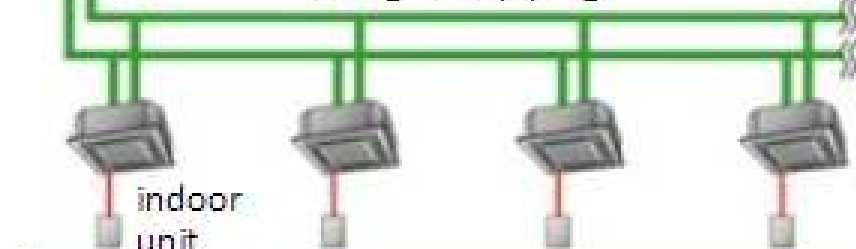

Individual control

Simple Operation

Split type air conditioning system

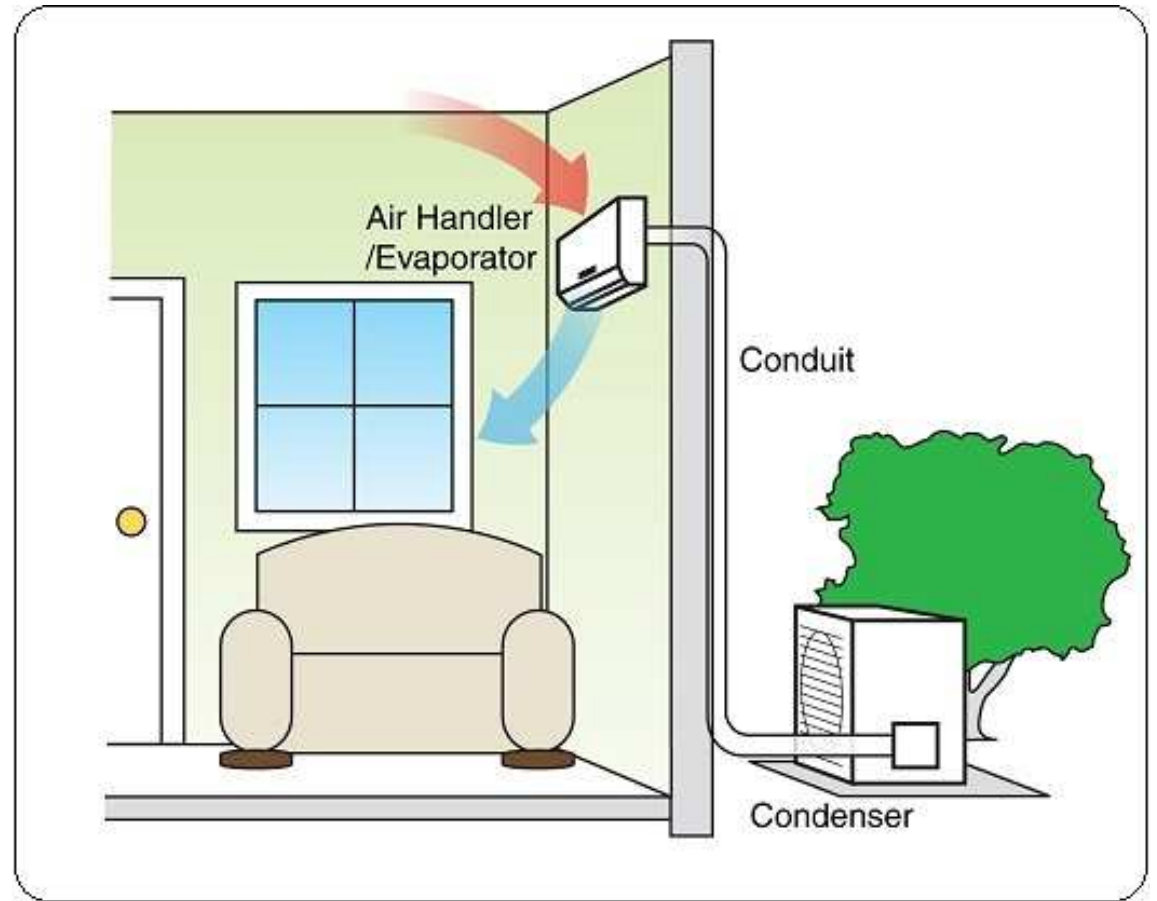



System Overview

- Split air-conditioning systems

- One indoor unit along with an outdoor unit
- Ductless; low initial cost; easy installation
- Limited pipe length and air throw



- Multi-split systems

- Multiple evaporator (indoor) units connected to one outdoor condensing unit
- Each indoor unit has its own set of refrigerant pipe work connecting it to the outdoor unit
 - More refrigerant lines
- Individual system control not possible





System Overview

- Main characteristics of VRF systems:
 - A common set of refrigerant piping
 - Flexible piping and minimise the refrigerant path
 - A common system control (with group controller)
 - Variable speed compressor
 - Inverter driven scroll compressor
 - Individualized comfort/zone control
 - Mix and match indoor units
 - Up to 150% connected capacity (with diversity)



System Overview

- Potential benefits of VRF systems:
 - Energy efficient and flexible piping design
 - Tight temperature/humidity control and quiet operation
 - The ability to have many zones, ease of installation
 - Long piping to form a centralized plant
 - Advanced building automation system (BAS) control
 - Modular design (scalable for expansion/reconfiguration):-
 - Installation can be built in stages in a flexible way
 - Large capacity can be formed (modular build up)
 - If you loose 1 condenser, you only loose a small part of the building; NOT the entire building

System Overview



- Video: HVAC VRF Basics - Variable Refrigerant Flow (7:58)



- http://www.youtube.com/watch?v=hzFOCuAho_4
 - Basic concepts of VRF prepared by <http://TheEngineeringMindset.com>
- Other videos on VRF HVAC Training:
 - <http://www.youtube.com/playlist?list=PLWv9VM947MKhs0zPB10LFZ1TnmmCh-NAj>



Components and Types

- Basic components of VRF systems:
 - 1) An outdoor unit with single or multiple compressors, variable capacity compressor (inverter-driven)
 - Can be air-cooled or water-cooled
 - 2) Refrigerant piping
 - With header, branch selector units, and zone control valves
 - 3) Indoor unit(s)
 - That have a coil, air movement device intended for single zone air distribution, and a temperature sensing control
 - Can be non-ducted, ducted or mixed
 - 4) System communications control network
 - With control wiring, controllers, linked to building automation

Basic components of a VRF system

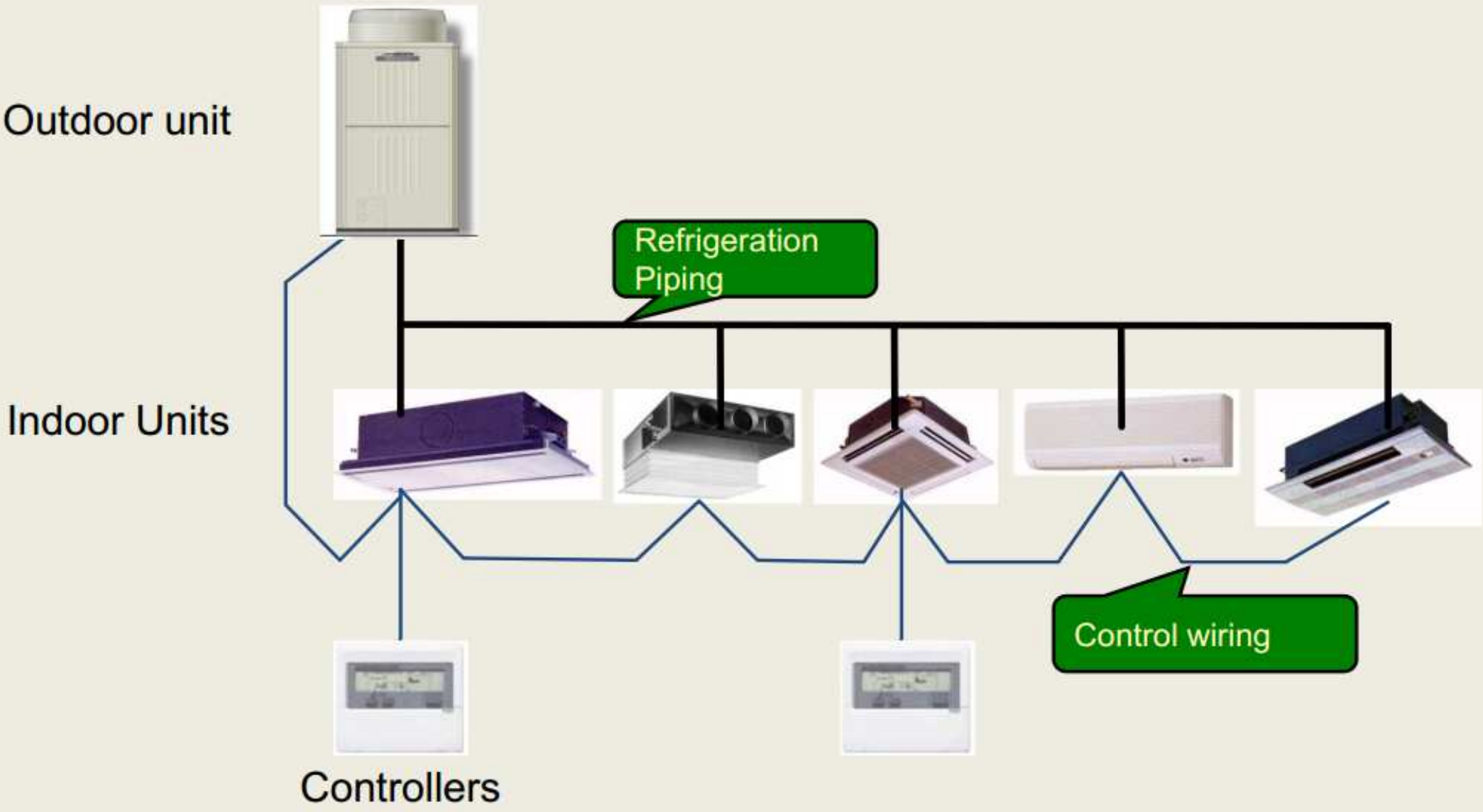

(Source: Roger Nasrallah, Enertrak Inc.)

Simplified schematic of VRF refrigerant circuit

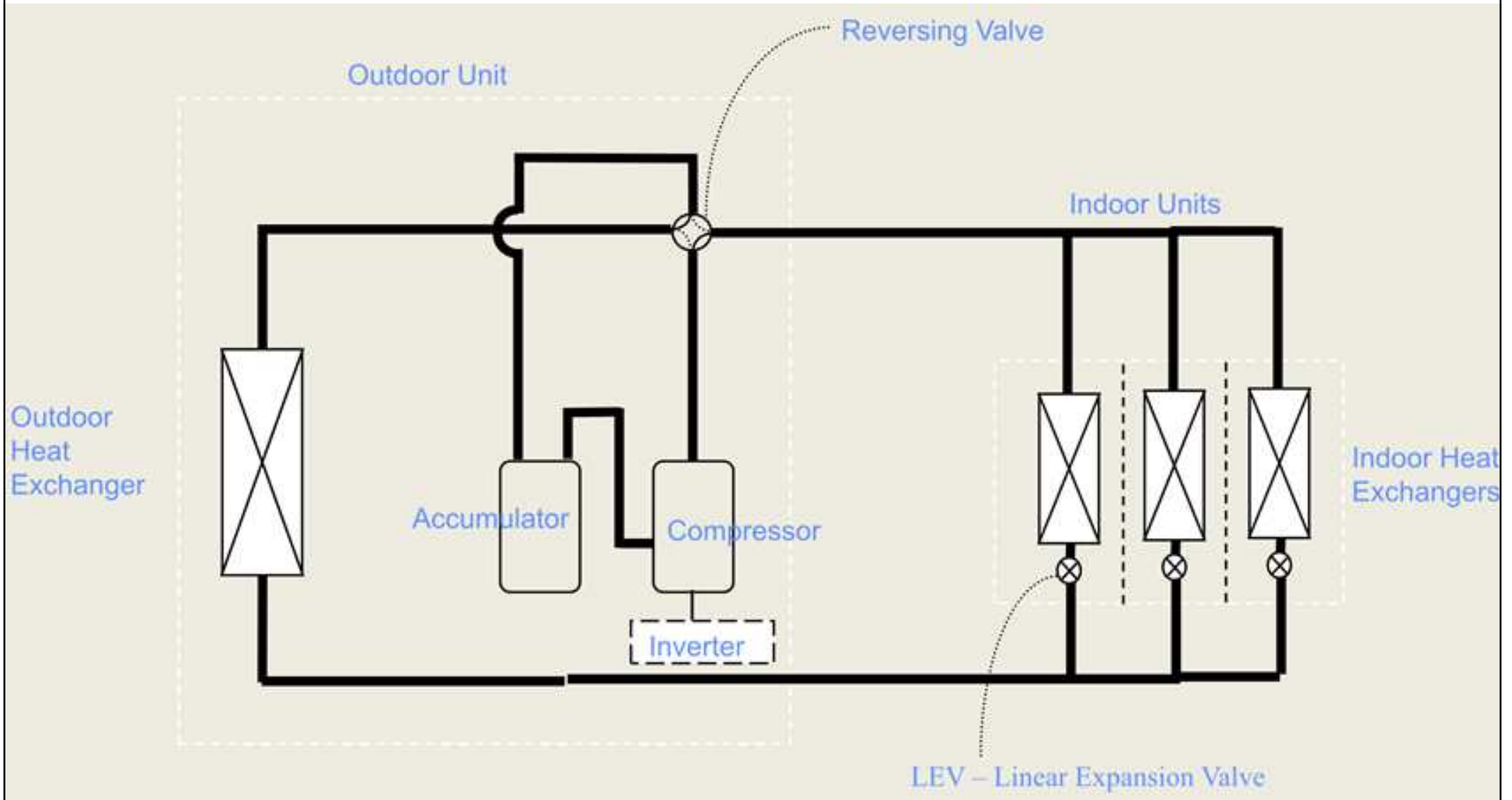

Do you know the function of each component?

VRF system for centralized air-conditioning in a high-rise commercial building in Manila, Philippines



(Source: Dr. Sam C. M. Hui)



The plant space design is different from chiller system.

An example of outdoor unit and compressor of VRF system

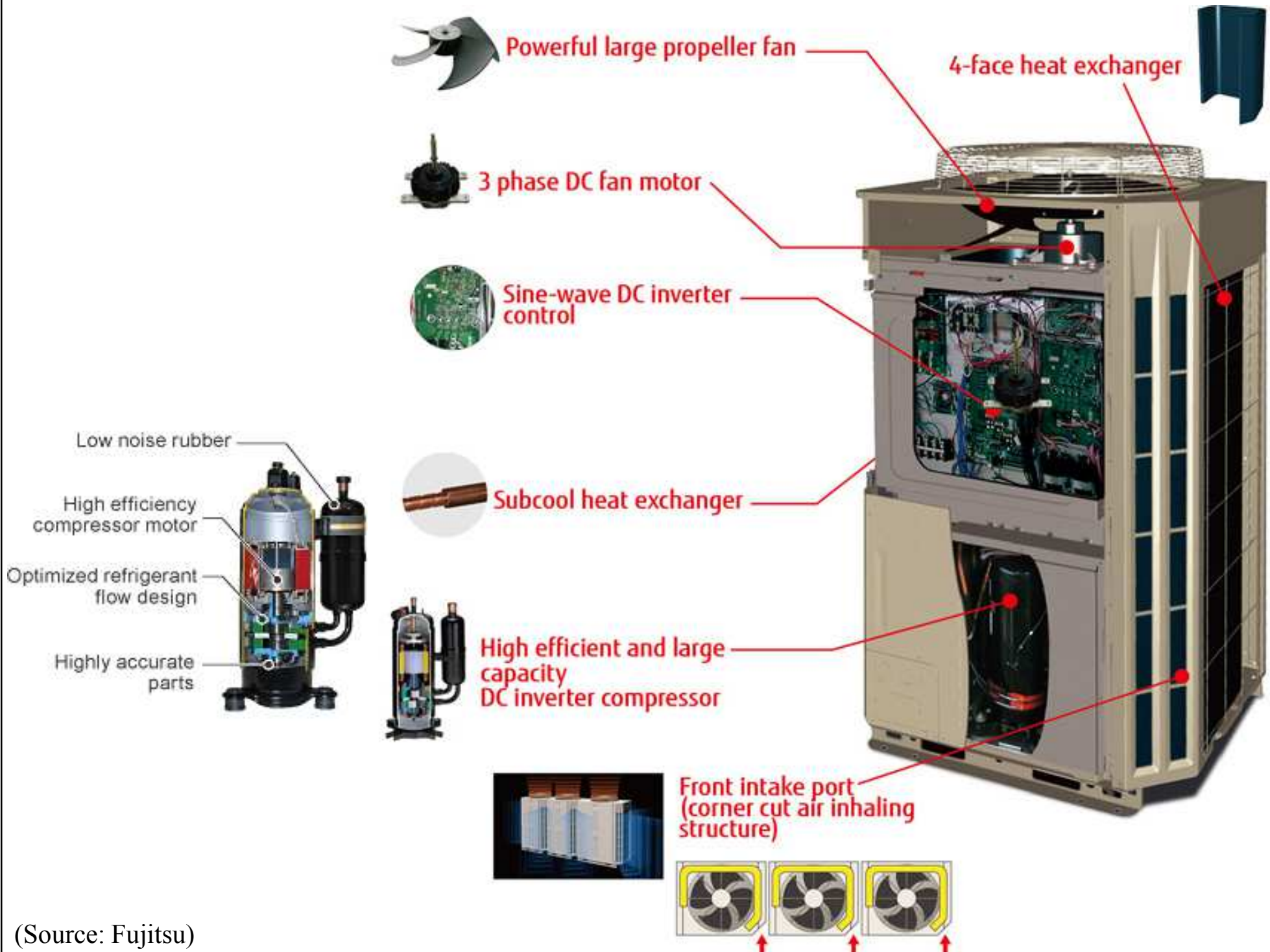

(Source: Fujitsu)

Variable refrigerant flow (VRF) system with mixed indoor units

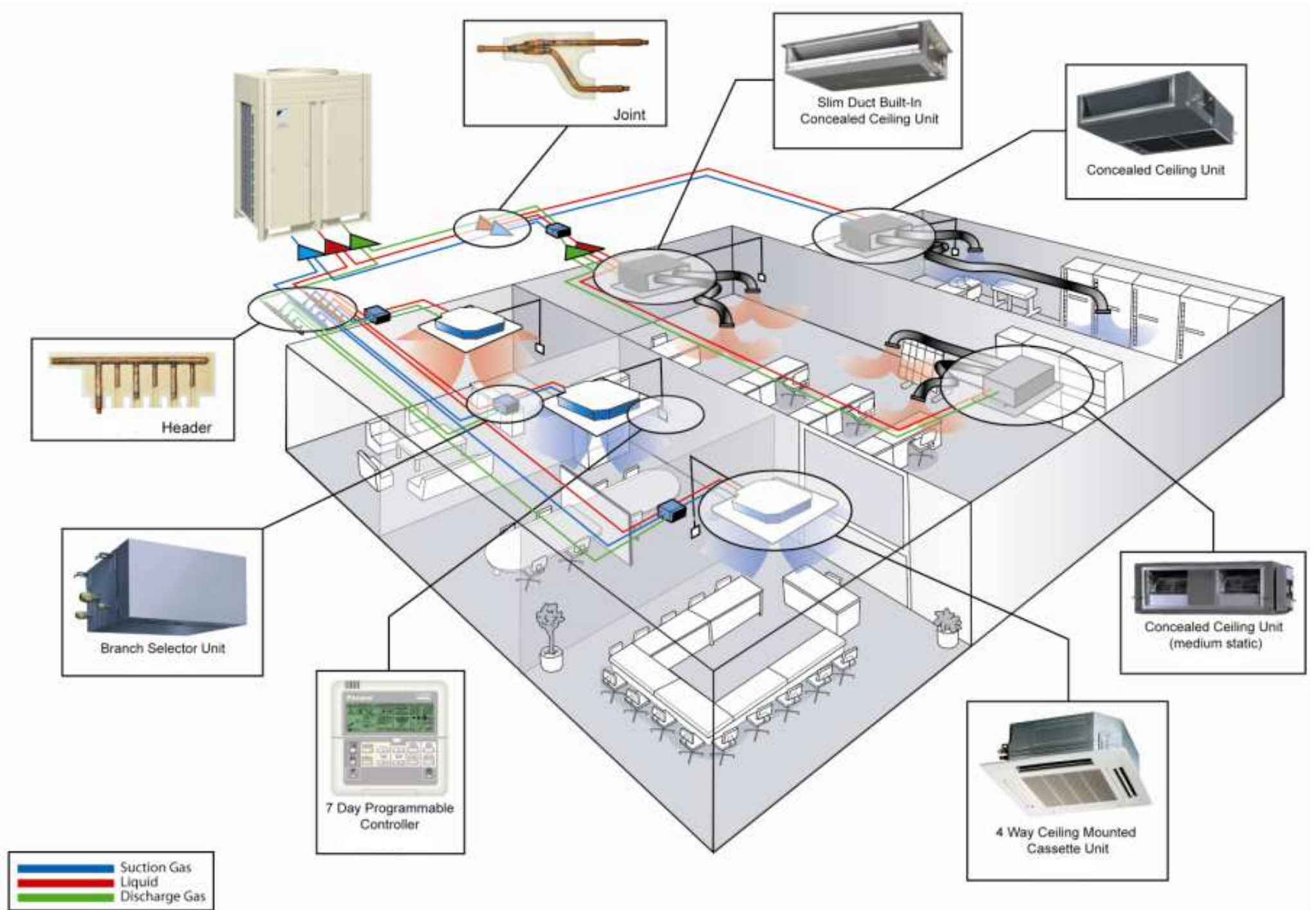

(Source: Daikin)



A. FOUR-WAY CEILING RECESSED CASSETTE



B. CEILING SUSPENDED

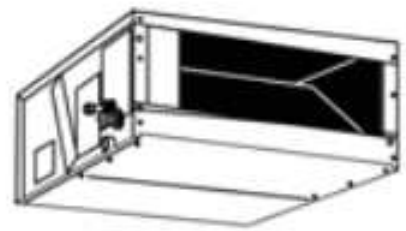

C. CEILING CONCEALED DUCTED



D. WALL MOUNTED

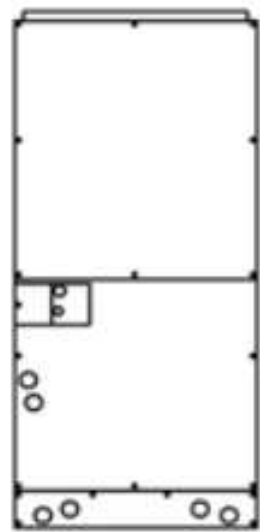

E. VERTICAL AIR HANDLER



F. ONE-WAY CEILING RECESSED CASSETTE



G. FLOOR-STANDING EXPOSED

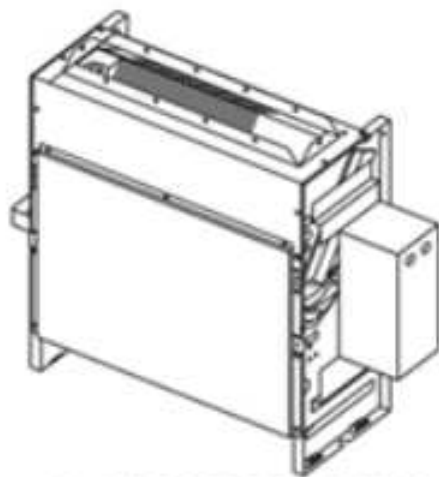

H. FLOOR-STANDING CONCEALED

Common types of VRF indoor units

Variable refrigerant flow (VRF) system --- refrigerant circuit and control communication devices

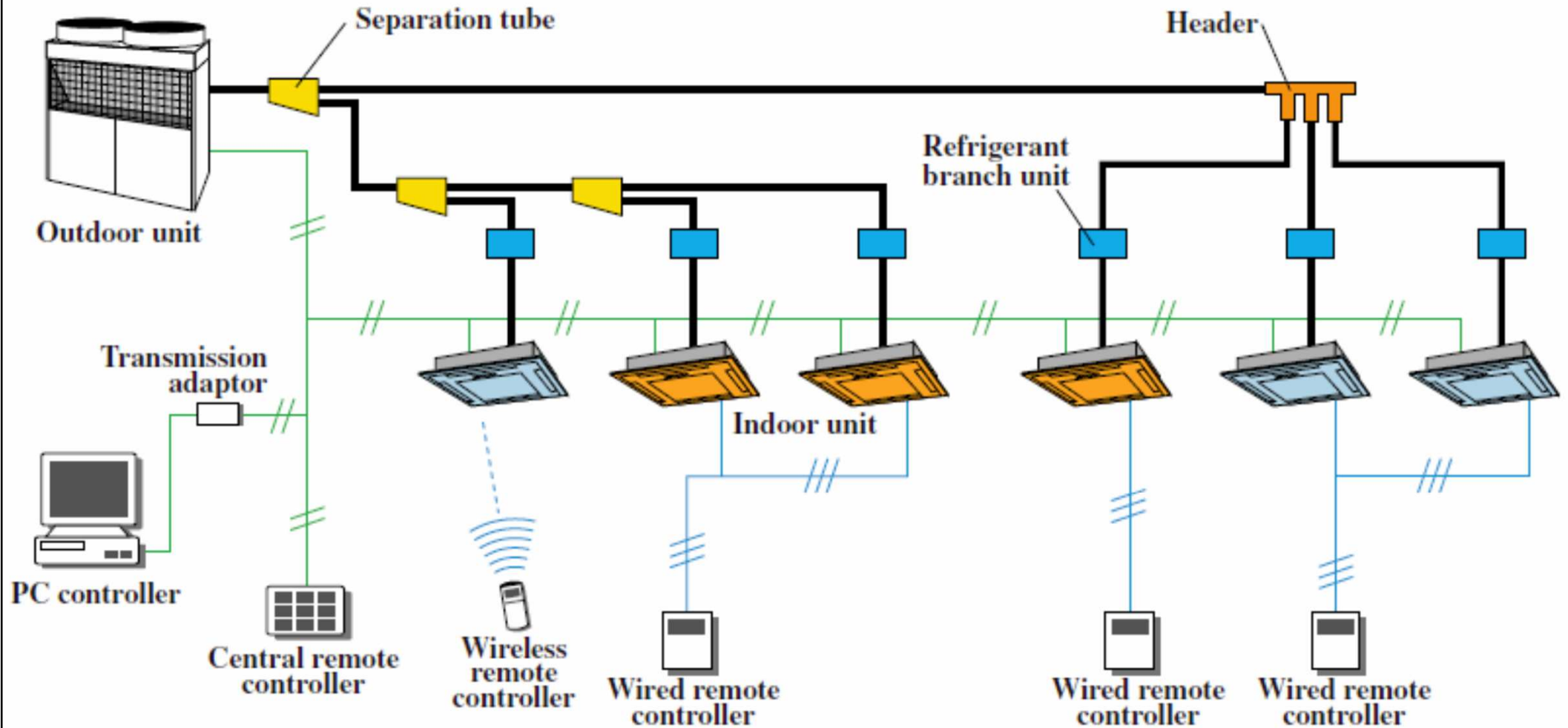



Components and Types

- Types of VRF systems:
 - Cooling only – heating is not available; fan & dry modes are available for each indoor unit
 - Heat pump – indoor units can be in either cooling or heating mode but all must be in the same mode if served by the same outdoor unit
 - Heat recovery – can provide simultaneous cooling & heating from the same outdoor unit, using 2 or 3 pipes (require a balance of heating and cooling demand); may deliver the heat into hot water

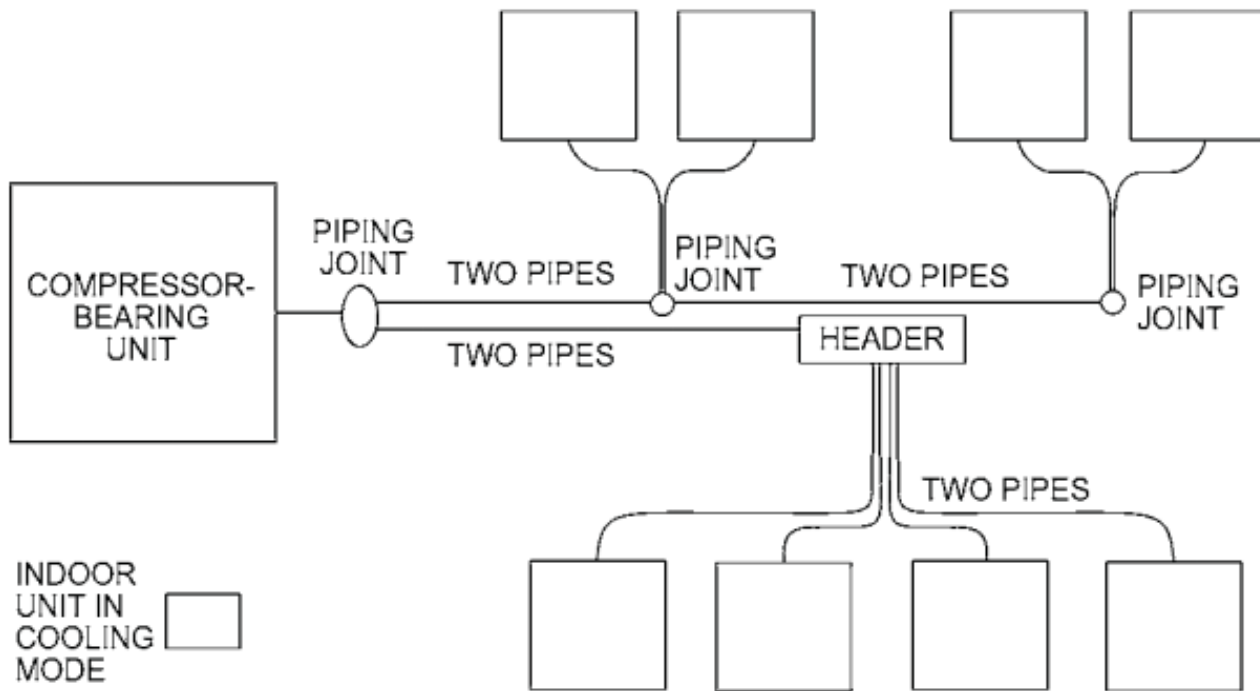

Cooling-only and heat pump VRF system

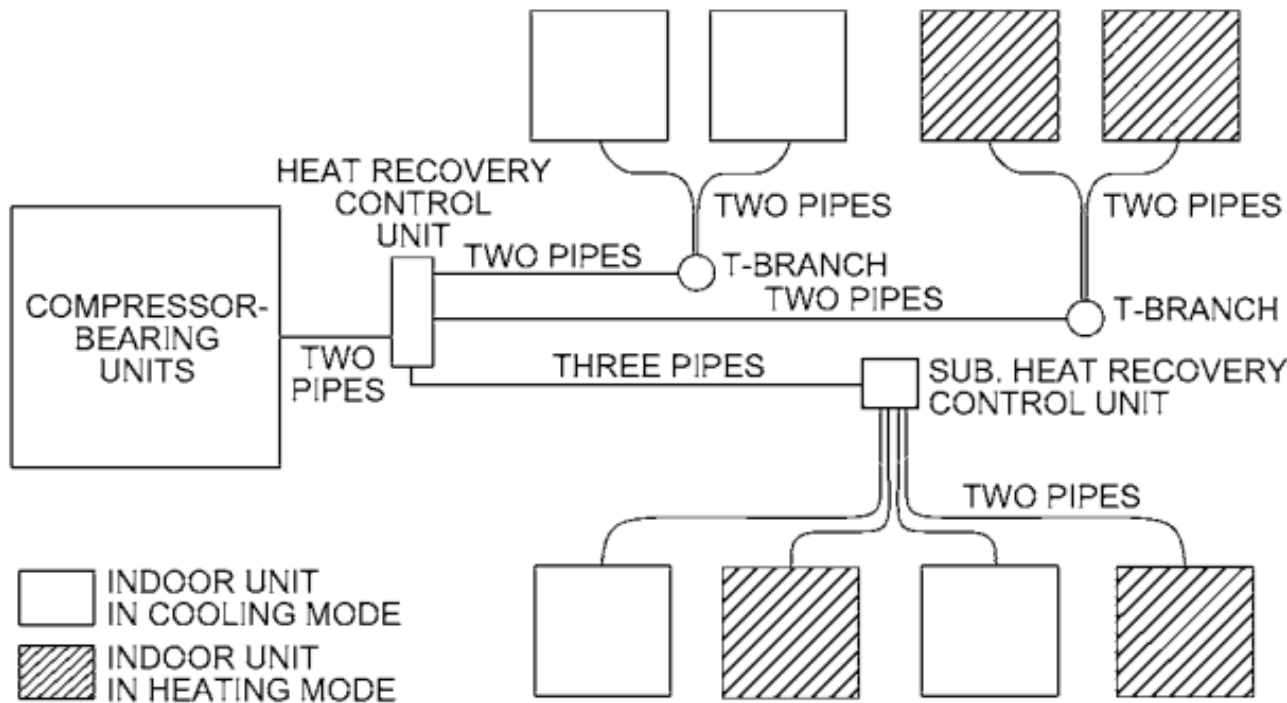

Two-pipe heat recovery VRF system

Heat pump and heat recovery VRF systems

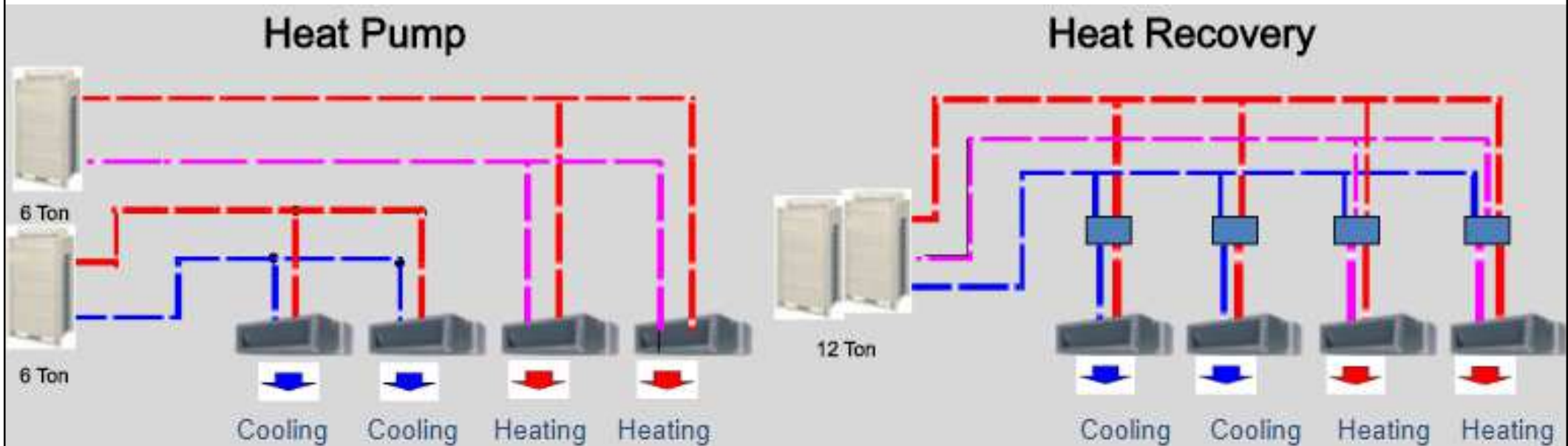

Heat pump VRF:

- 2-pipe system
- heat/cool changeover

Heat recovery VRF:

- 3-pipe system
- Can provide simultaneous cooling & heating
- Extra heat exchangers in distribution boxes are used to transfer some reject heat from superheated refrigerant existing the cooling zone to the refrigerant going to the heating zone

Variable refrigerant flow (VRF) system with heat recovery

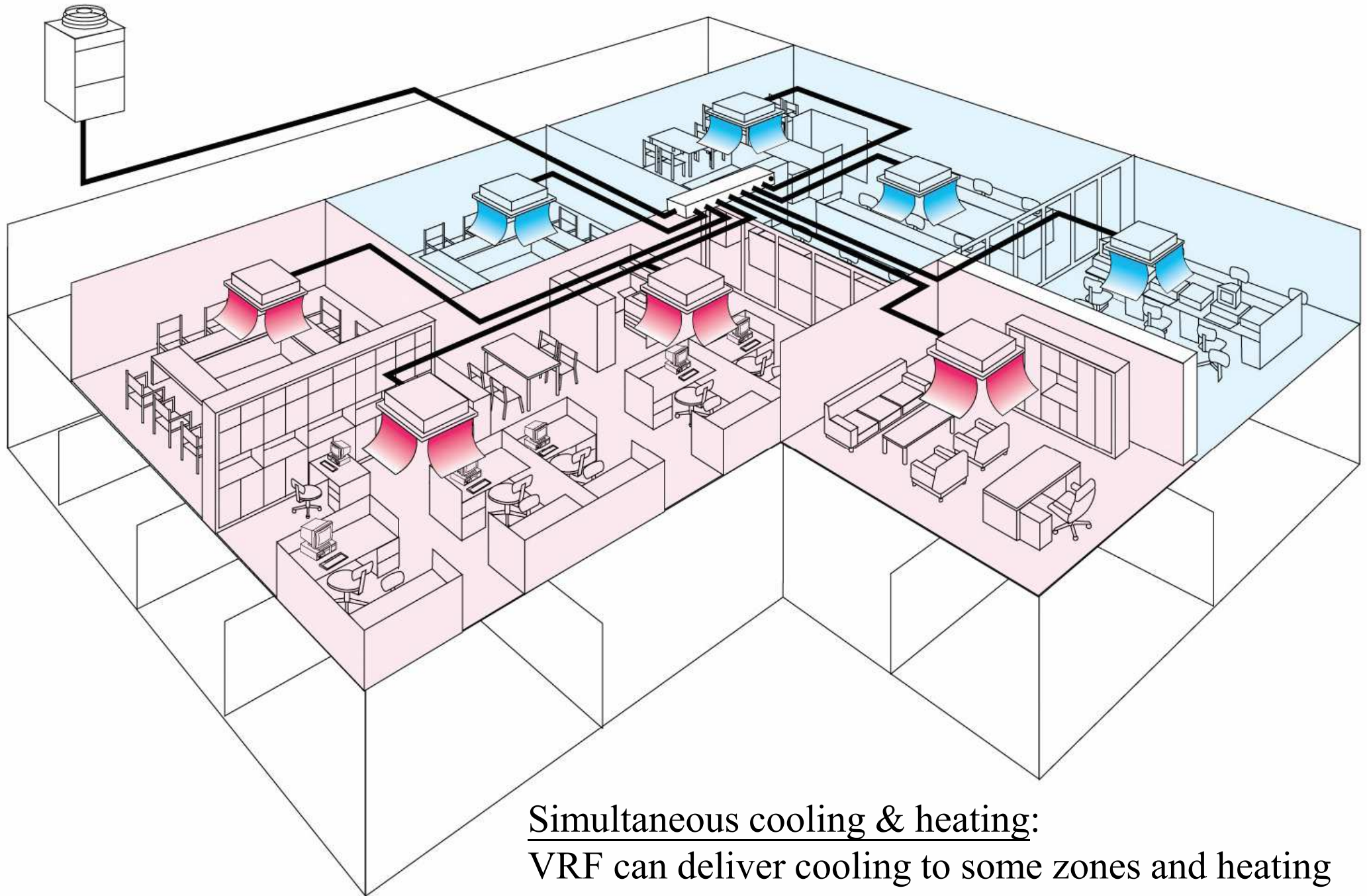

Simultaneous cooling & heating:
VRF can deliver cooling to some zones and heating to others, with no reheat needed.

System Operation

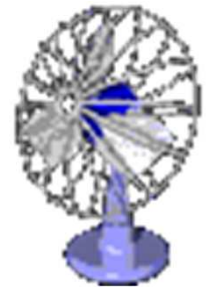

- Compressor arrangements for VRF systems:
 - 1. Single variable speed compressor
 - One large-capacity scroll compressor; no redundancy
 - 2. Variable speed compressor + fixed speed compressor
 - The inverter-driven compressor always starts and ramps up until it reaches its maximum capacity at which time the fixed-speed compressor starts and the inverter driven compressor ramps down
 - 3. Multiple variable speed compressors
 - Provides greater back-up capability
 - Rotating operation of compressors, equalizing their operating time
 - Better part load performance without the need to use hot gas bypass

Compressor operation at part load

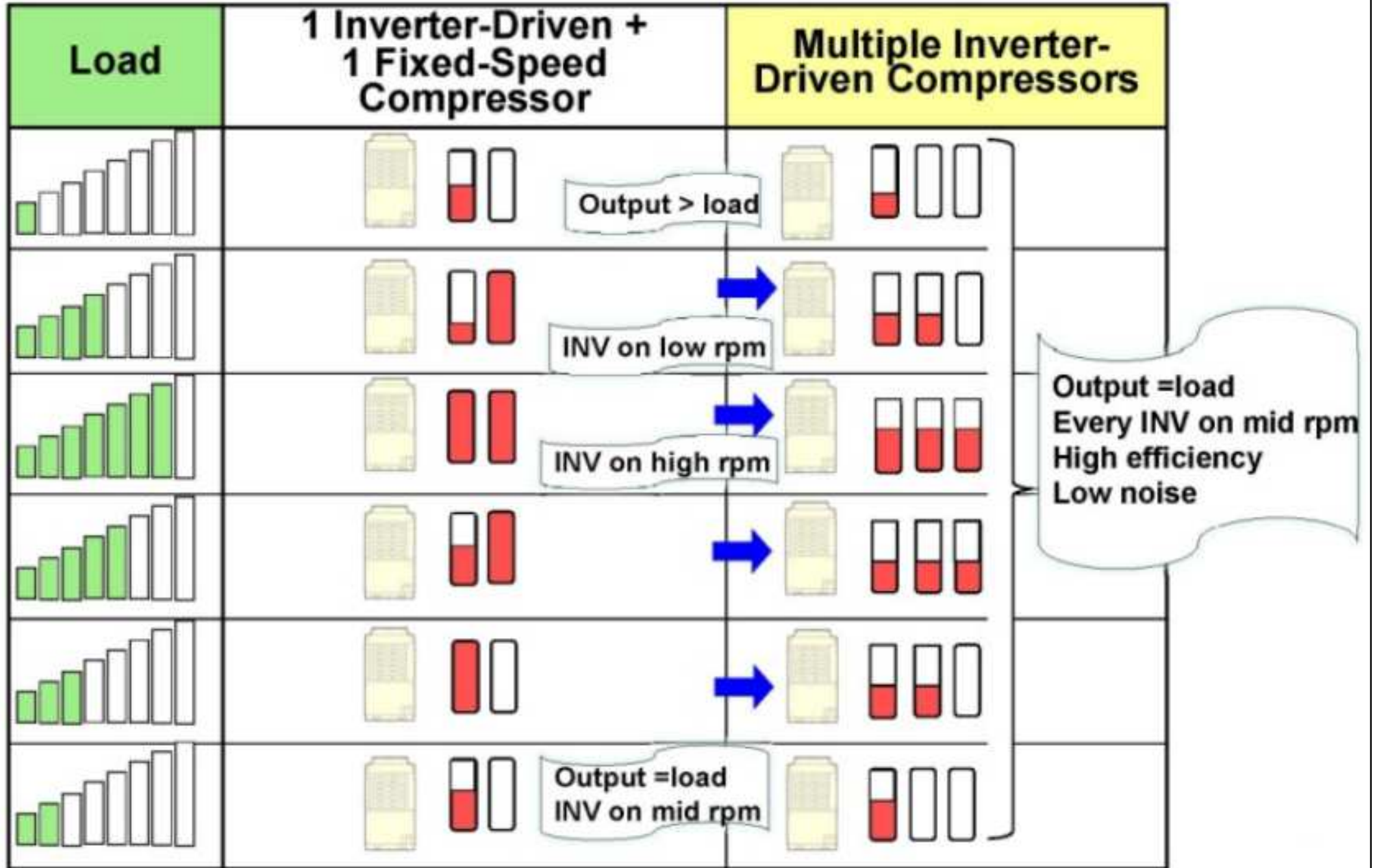

System Operation

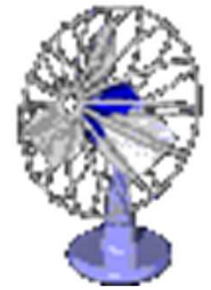

- **Inverter drive system** of VRF:
 - Also known as variable frequency drive (VFD)
 - The DC inverter control adjusts the supply frequency
 - Thus the rotational speed of the compressor is controlled
 - Exactly the right amount of refrigerant gas is pumped to meet the cooling requirements (part-load demand)
 - Can also adjust condenser fan speed
- **Digital scroll technology**
 - Variable capacity adjustment is achieved by PWM (Pulse width modulation) electronic expansion valve (EEV)



Inverter-driven compressor control in VRF systems

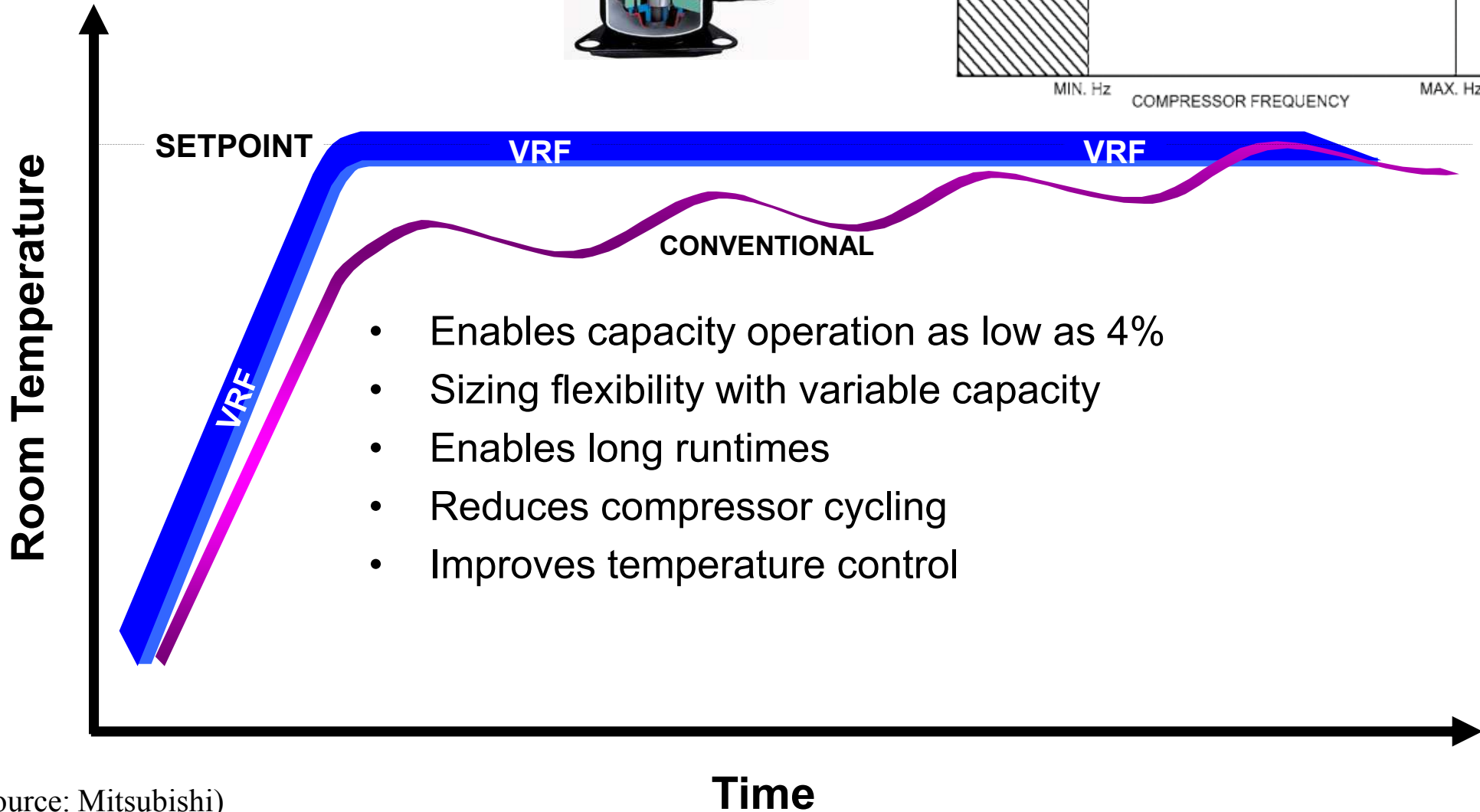
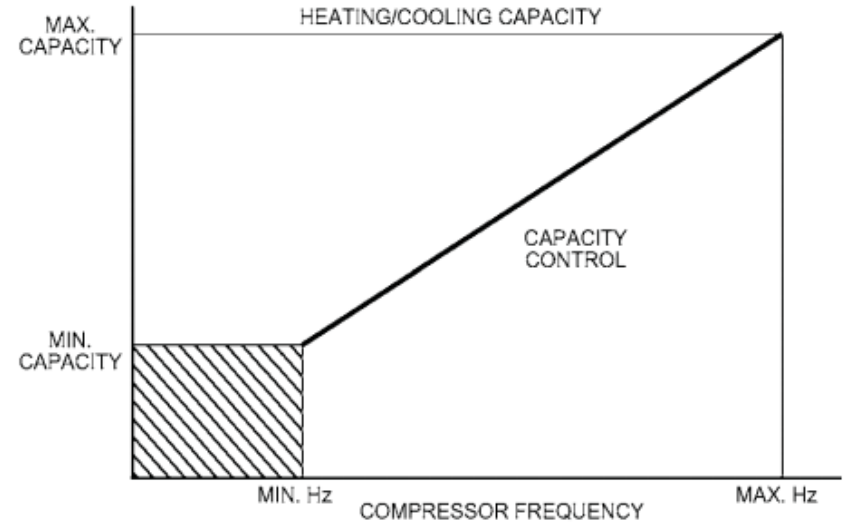

Room temperature control by inverter technology

Conventional Model

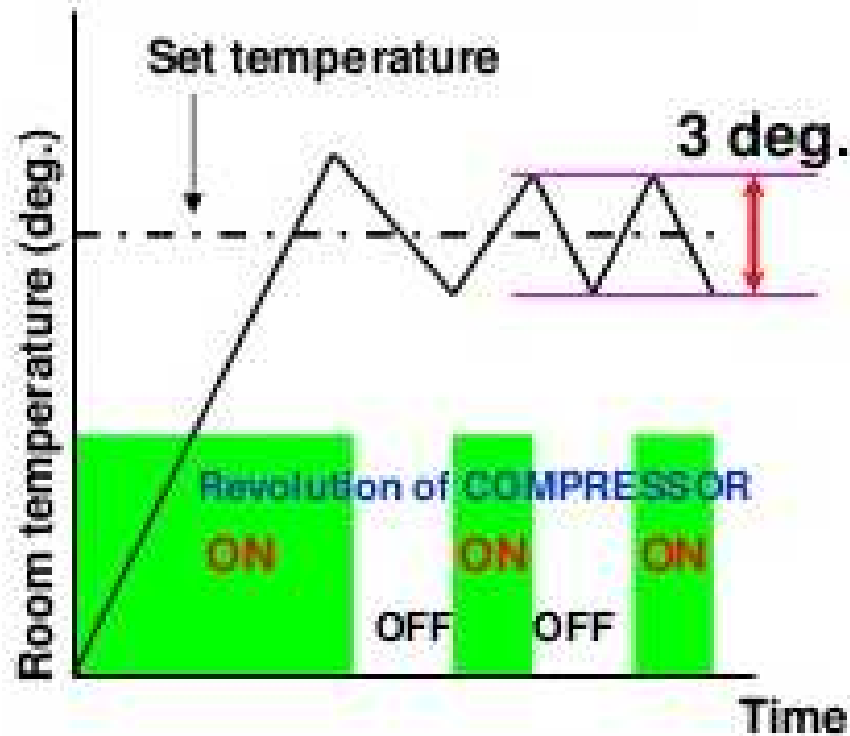

Conventional: Room temperature drops rapidly when compressor turns OFF which result in an unstable room temperature.

Inverter

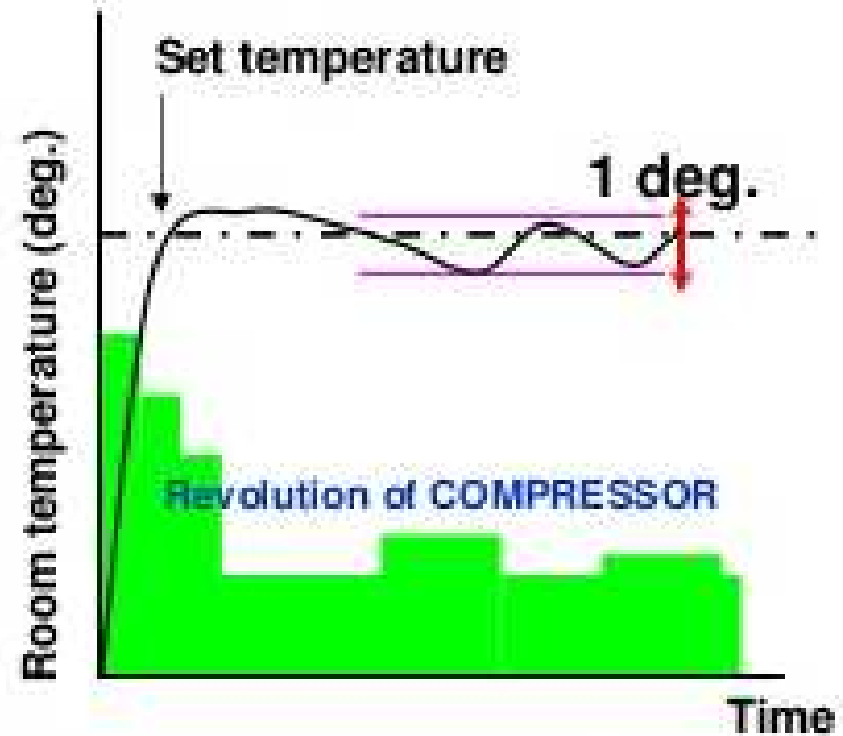

Inverter: Range of room temperature change is small. Because after set temp is reached, compressor will not shut off to control temp but will maintain temp by decreasing or increasing revolution.

How do VRF systems work?

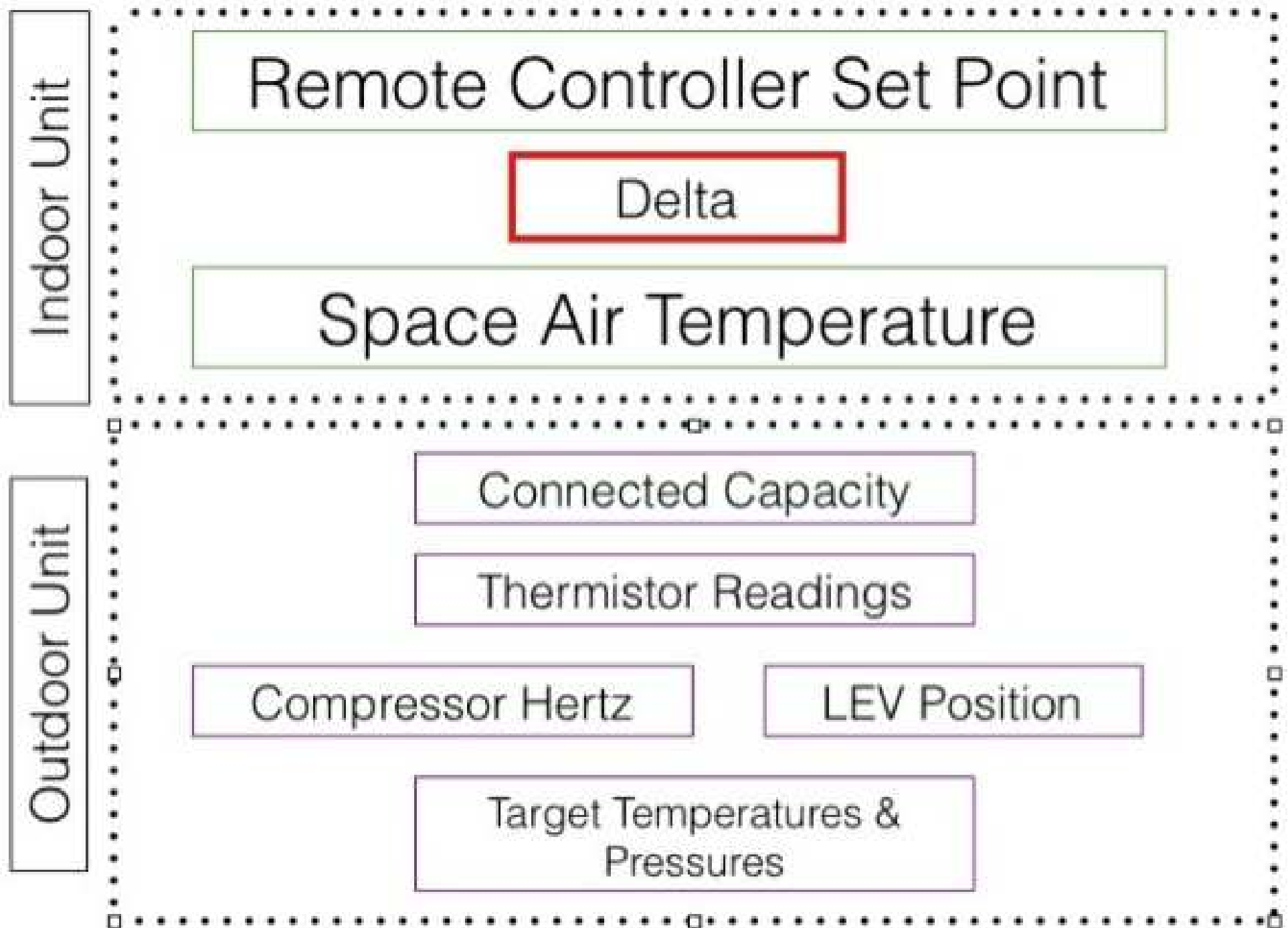

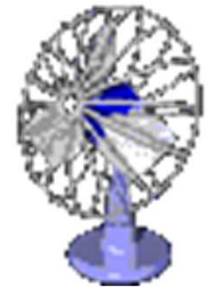

System Operation

- VRF refrigerant & room temperature control:
 - Electronic expansion valve (EEV) or linear expansion valve (LEV) using proportional, integral & derivative (PID)
 - Continuously adjusts the refrigerant volume in response to load variations (with PID control feedback)
 - Comfortable room temperature is maintained without wide temperature swing

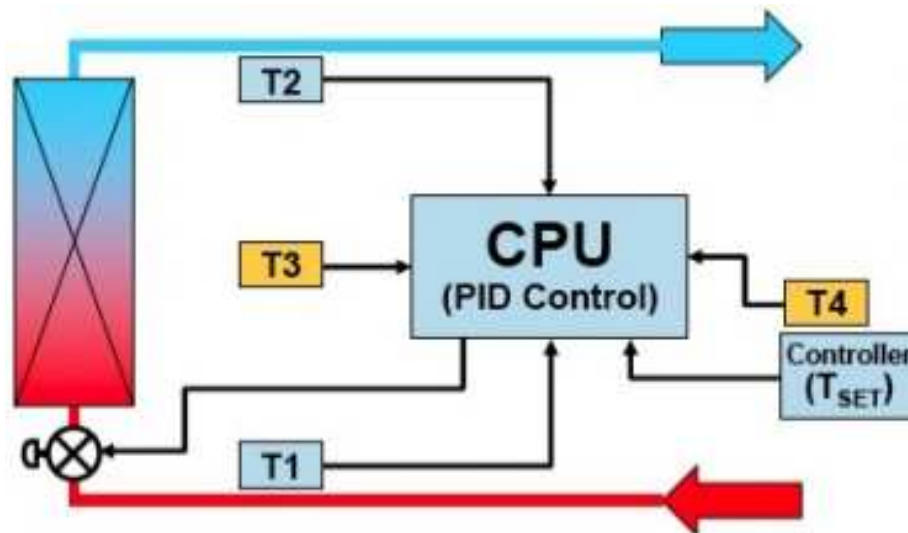

LEGEND

- T1: Refrigerant Liquid Line Temp.
- T2: Refrigerant Suction Line Temp.
- T3: Return Air / Remote Sensor Temp.
- T4: Controller Temperature Sensor
- T_{SET}: Controller Set Point Temp.

System Operation

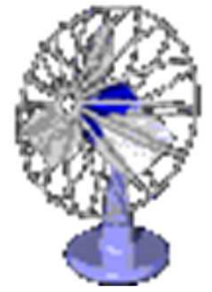

- Indoor unit capacity control

- Indoor units individually controlled by LEV



- LEV has two functions:

- Control the superheat across indoor unit evaporator
 - Acts as solenoid valve to stop refrigerant flow to indoor units that are off

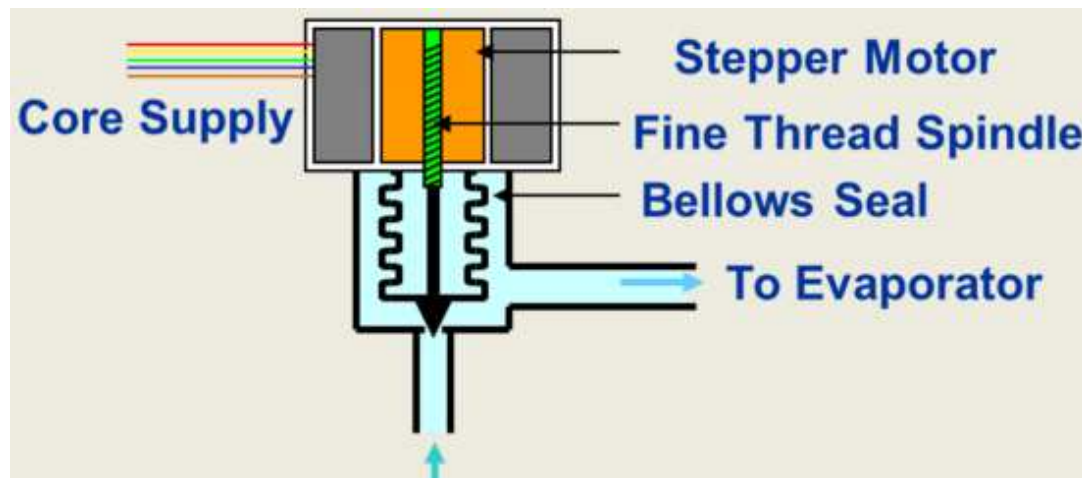

System Operation

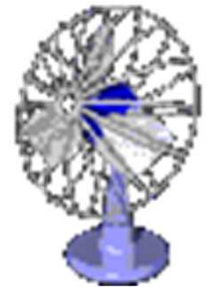

- Outdoor unit capacity control
 - Compressor speed is controlled by a VFD based on common saturated suction temperature and capacity required
 - Refrigerant volume flow is directly proportional to the compressor speed
 - Power input is directly proportional to the cube of the compressor speed



System Operation

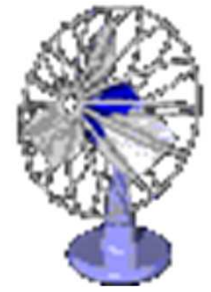

- Controls & network
 - Integrated digital control system
 - Using direct digital control (DDC)
 - Daisy chain connection
 - Integrated into building management system (BMS) & energy management system (EMS)
 - Can do energy metering & analysis

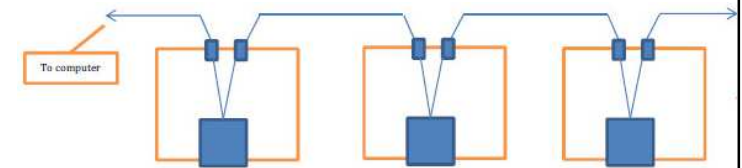

- Typical control components:
 - Central system control
 - Zone control
 - PC-based controls (web browser function)
 - Mobile devices (e.g. phones & tablets)



Example of VRF control network using BACnet

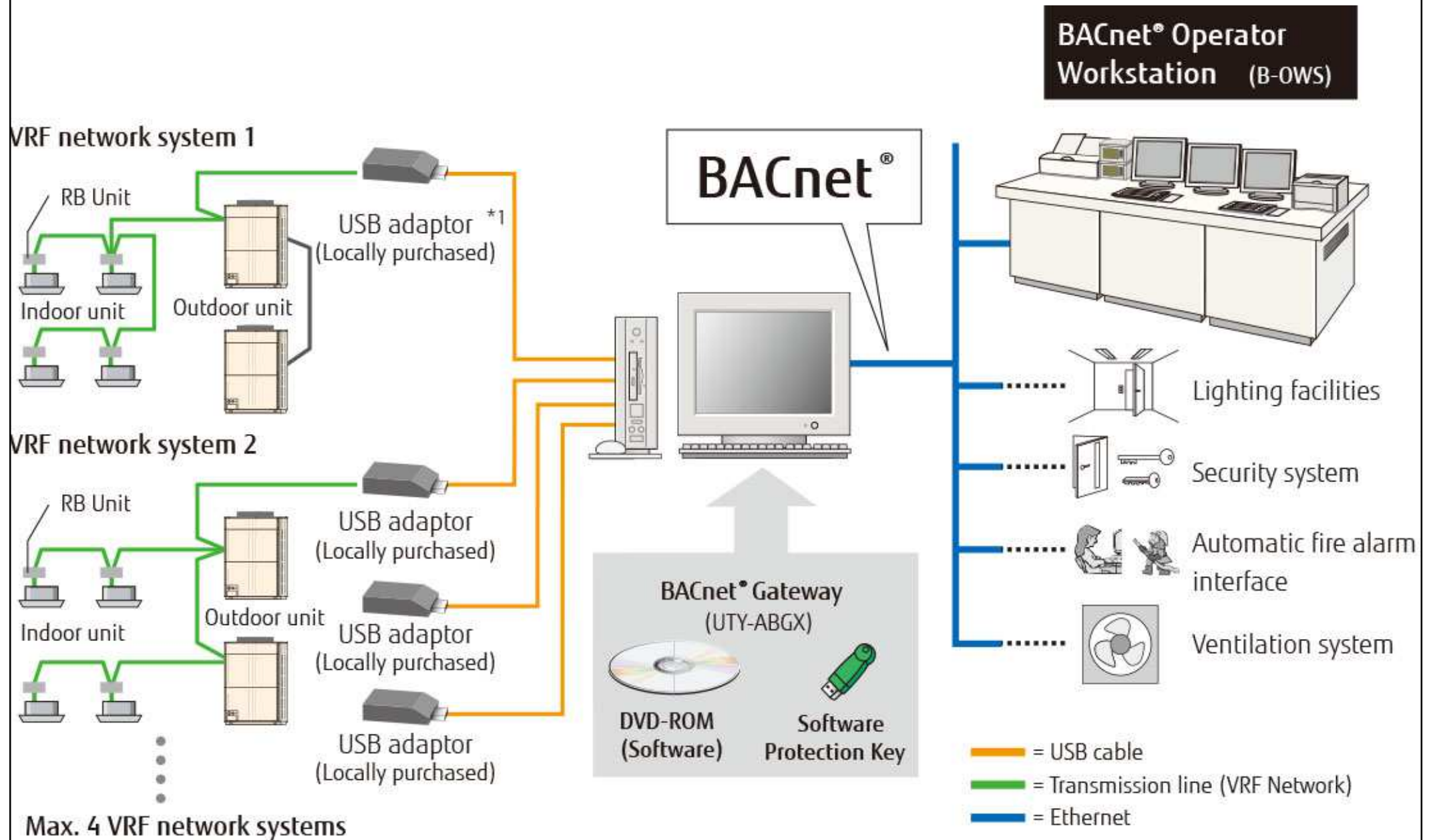

*1: USB adaptor is U10 USB Network Interface of Echelon® Corporation.

BACnet = Building automation control network (from ASHRAE)

(Source: Fujitsu)

Design Issues



- Pipe design

- The long pipe lengths will introduce pressure losses in the suction line and, unless correct diameter of pipe is selected, the indoor units will be starved of refrigerant resulting in insufficient cooling to the end user
- So it is very important to make sure that the pipe sizing is done properly, both for the main header pipe as well as the feeder pipes that feed each indoor unit
 - Maximum allowable vertical distance between an outdoor unit and its farthest indoor unit; maximum permissible vertical distance between two individual indoor units
 - Maximum overall refrigerant piping lengths between outdoor and the farthest indoor unit

Pipe length limits of typical VRF systems

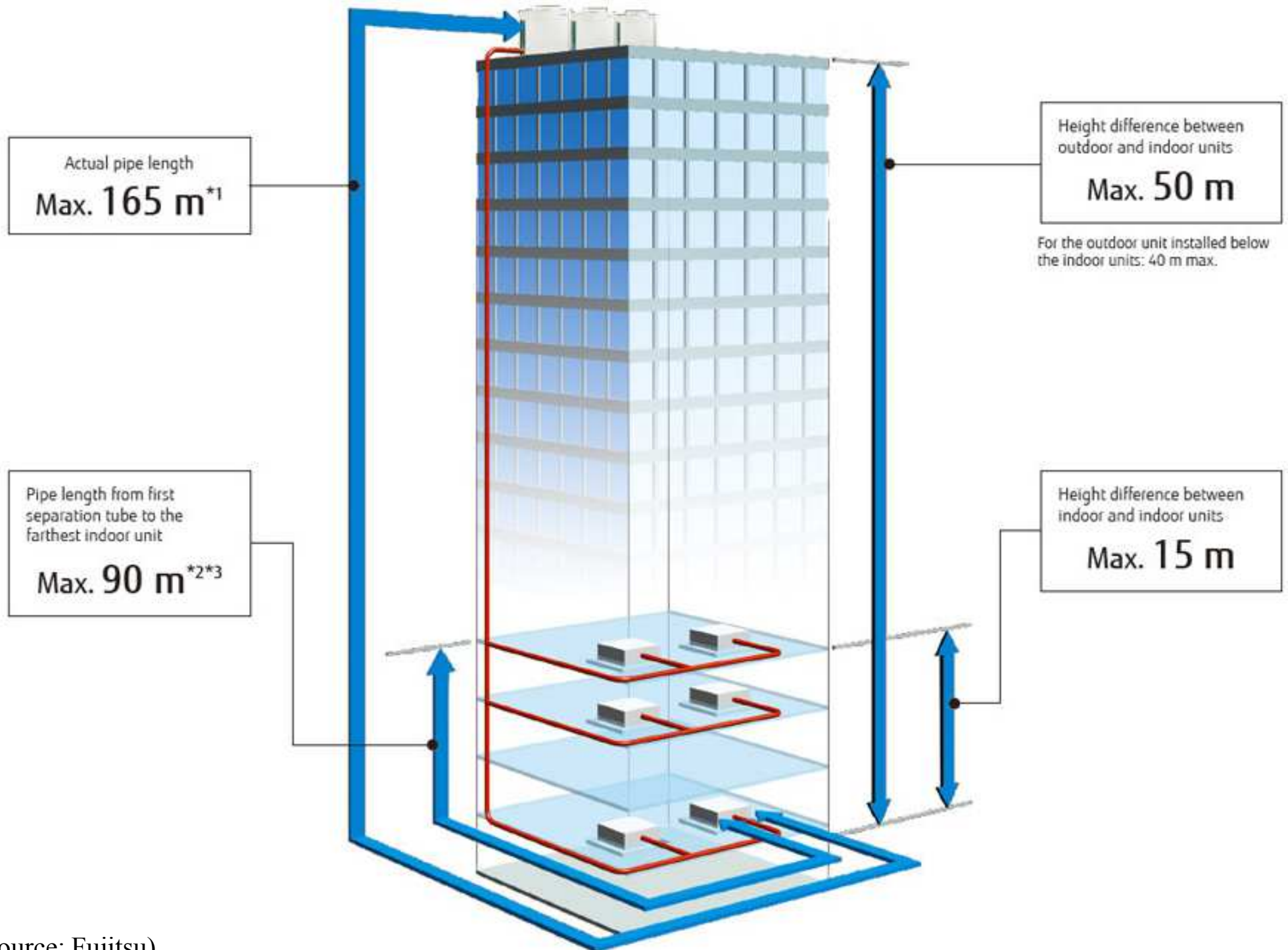

Example of VRF piping design

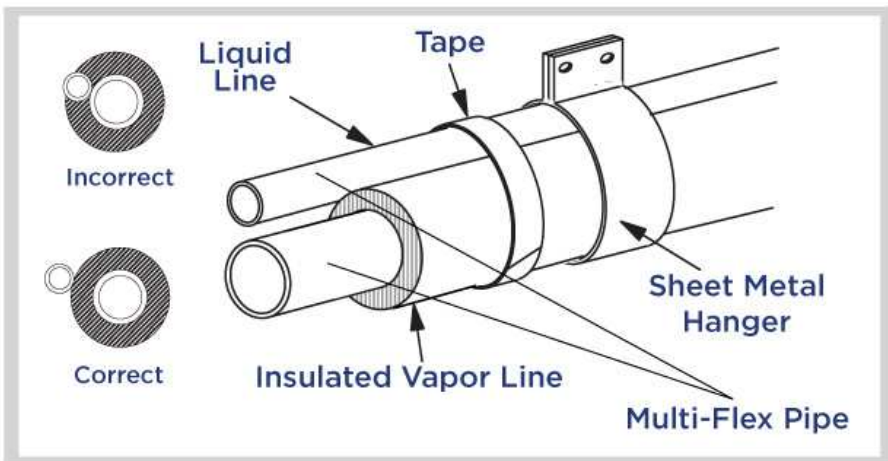
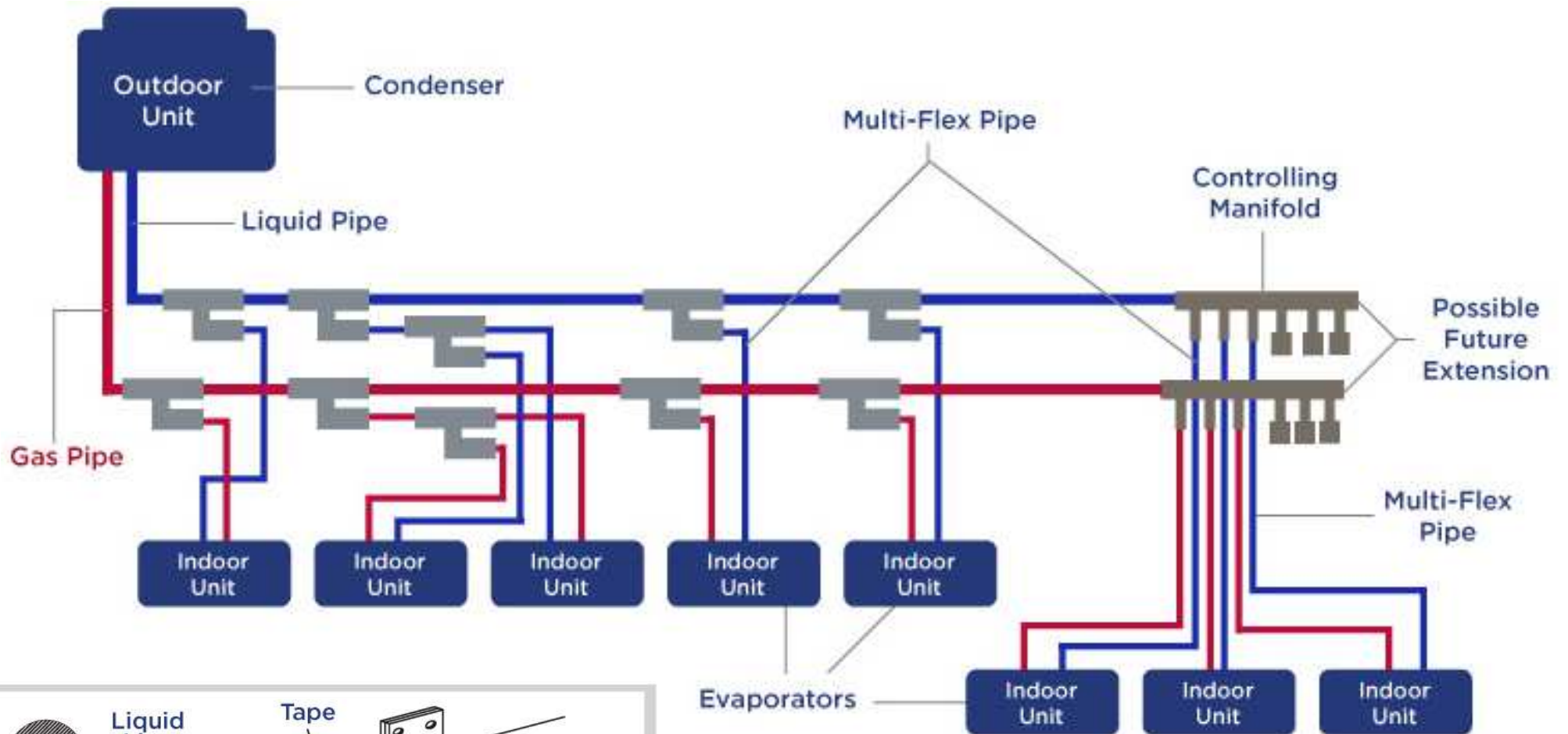

Refrigeration Line Support





Design Issues

- Design VRF system for flexible installation
 - VRF systems are lightweight; require less outdoor plant space (can fit into different spaces)
 - Floor by floor installation and commissioning
 - A multiple of the units can be installed to achieve cooling capacities of hundreds of tons
 - It is less disruptive to fit in existing buildings (particularly when occupied) and its modular format lends itself to phased installations

Example of VRF system piping in a historic building



(Source: Allen Anaya, W M Carroll LLC)

Design Issues



- Lubrication oil return

- Oil return is important to ensure that there is adequate lubrication for the compressor, especially during part load operation
- Reducing oil logging in the system improves heat exchange efficiency in the condenser and evaporators saving energy
- Oil separators collect most of the oil; however, a small amount of oil remains entrained in the refrigerant, and often collects in the piping system and indoor units
- After a certain amount of runtime, the system will perform its Oil Return function, returning the oil to the outdoor unit



Design Issues

- Energy performance of VRF systems
 - Linear step control in conjunction with inverter and constant speed compressor combination
 - Adjust compressor speed to its optimal energy usage
 - Allows more precise control of the necessary refrigerant circulation amount required according to the system load (smooth capacity control)
 - High part-load and seasonal efficiency
 - Minimizes or eliminates ductwork completely
 - Reduce duct losses and fan energy

Typical energy efficiency ratio (EER) of VRF systems

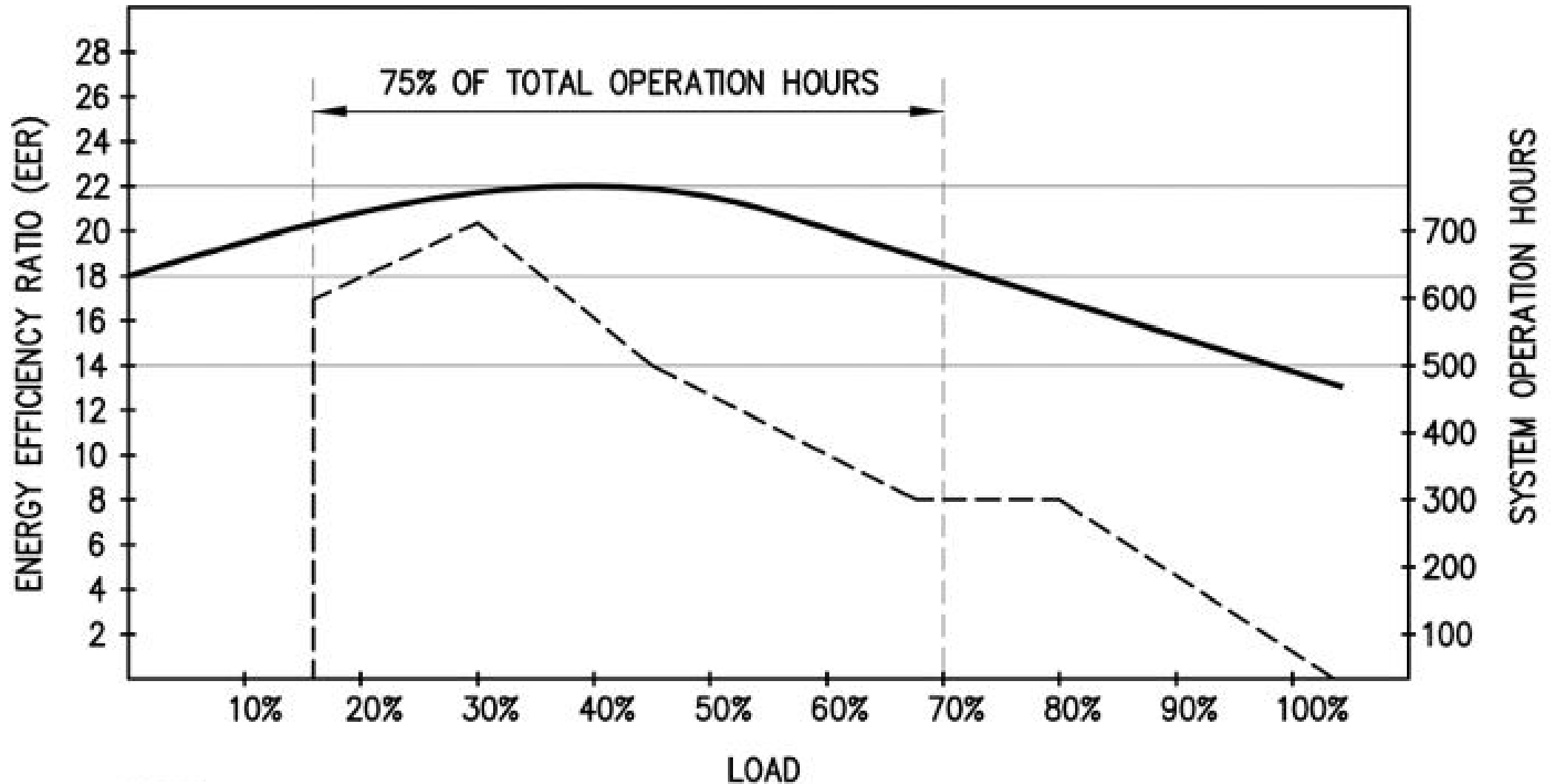

NOTE:

75% OF TOTAL OPERATION HOURS – VRF SYSTEM OPERATES AT LESS THAN 70% OF FULL LOAD.

Energy efficiency ratio (EER)
= (output cooling energy) /
(input electrical energy)



Design Issues

- Coefficient of performance (COP)
 - Ratio of energy output compared to energy input
- VRF cooling COP: 6.3
 - Air cooled chiller: 2.8
 - Geothermal heat pumps: 4.5
- VRF heating COP: 4
 - Electric heat: 1.0
 - Gas heat: 0.92
 - Hot water: 0.85

VRF system efficiencies: Sample VRF energy model curve

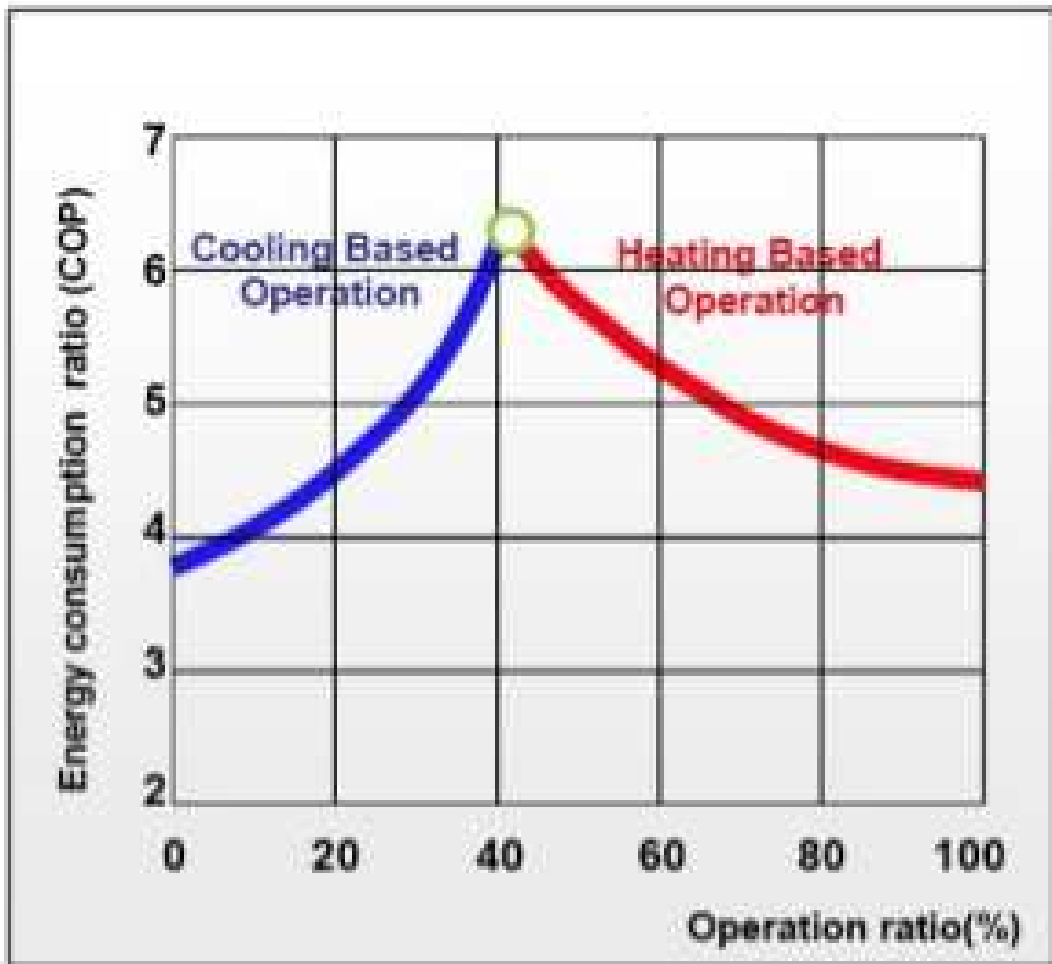

SYSTEM Efficiencies

- 100% Cooling
- 3.6 COP = 12.3 EER = .97 KW/Ton

- 100% Heating
- 4.3 COP = 14.6 EER = .82 KW/Ton

- 40% Clg / 60% Htg
- 6.3 COP = 21 EER = .57 KW/Ton

- 60% Clg / 40% Htg
- 5.2 COP = 17.7 EER = .67 KW/Ton

COP = coefficient of performance

EER = energy efficiency ratio

Operation ratio (%) for cooling and heating

(See also: <http://www.cibsejournal.com/cpd/modules/2013-04/>)



Design Issues

- Safety standard compliance for VRF and any DX systems are the same
 - Often refer to ASHRAE Standards 15 and 34 for safety practices, refrigerant safety classification, and **refrigerant concentration limit (RCL)** information
- Major safety factors:
 - Total amount of refrigerant used in the system
 - Individual occupied zone(s) geometry and connected zones, if applicable
 - Methodology to calculate the maximum amount of refrigerant that can be safely dispersed into a specific zone



Design Issues

- According to ASHRAE Standard 15, a VRF system is classified as a direct system/high-probability system where a refrigerant leak can potentially enter into the occupied space
- Occupancy classification
 - The ability of people to respond to potential exposure to refrigerant (speed of evacuation):
 - Public assembly, Residential, Commercial, Large mercantile, Industrial, Mixed, Institutional



Design Issues

- Refrigerant safety group classification
 - Degree of probability that a leakage of refrigerant will enter an occupancy-classified area
 - Toxicity: Class A (lower); Class B (higher)
 - Flammability:
 - Class 1 – no flame propagation
 - Class 2 – lower flammability
 - Class 3 – higher flammability
 - VRF systems often use refrigerant R-410a or R-32
 - R-410a: Class A1
 - R-32: Class A2L

Refrigerant safety group classification

		SAFETY GROUP		
I N C R E A S I N G	F L A M M A B I L I T Y	Higher Flammability	A3	B3
		Lower Flammability	A2	B2
			A2L*	B2L*
		No Flame Propagation	A1	B1
		Lower Toxicity	Higher Toxicity	
		INCREASING TOXICITY		

* A2L and B2L are lower flammability refrigerants with a maximum burning velocity of ≤ 10 cm/s (3.9 in./s).



Design Issues

- Outdoor air supply
 - VRF systems provide only space cooling and heating by recirculating air within the space
 - Outdoor air has to be provided separately
 - Fresh air can be ducted to the indoor units directly or even be introduced by natural ventilation
 - Often, a separate dedicated outside air system (DOAS) will be used
 - May also have energy or heat recovery

To meet the indoor air quality (IAQ) requirements, VRF systems are often integrated with a dedicated outdoor air unit/system

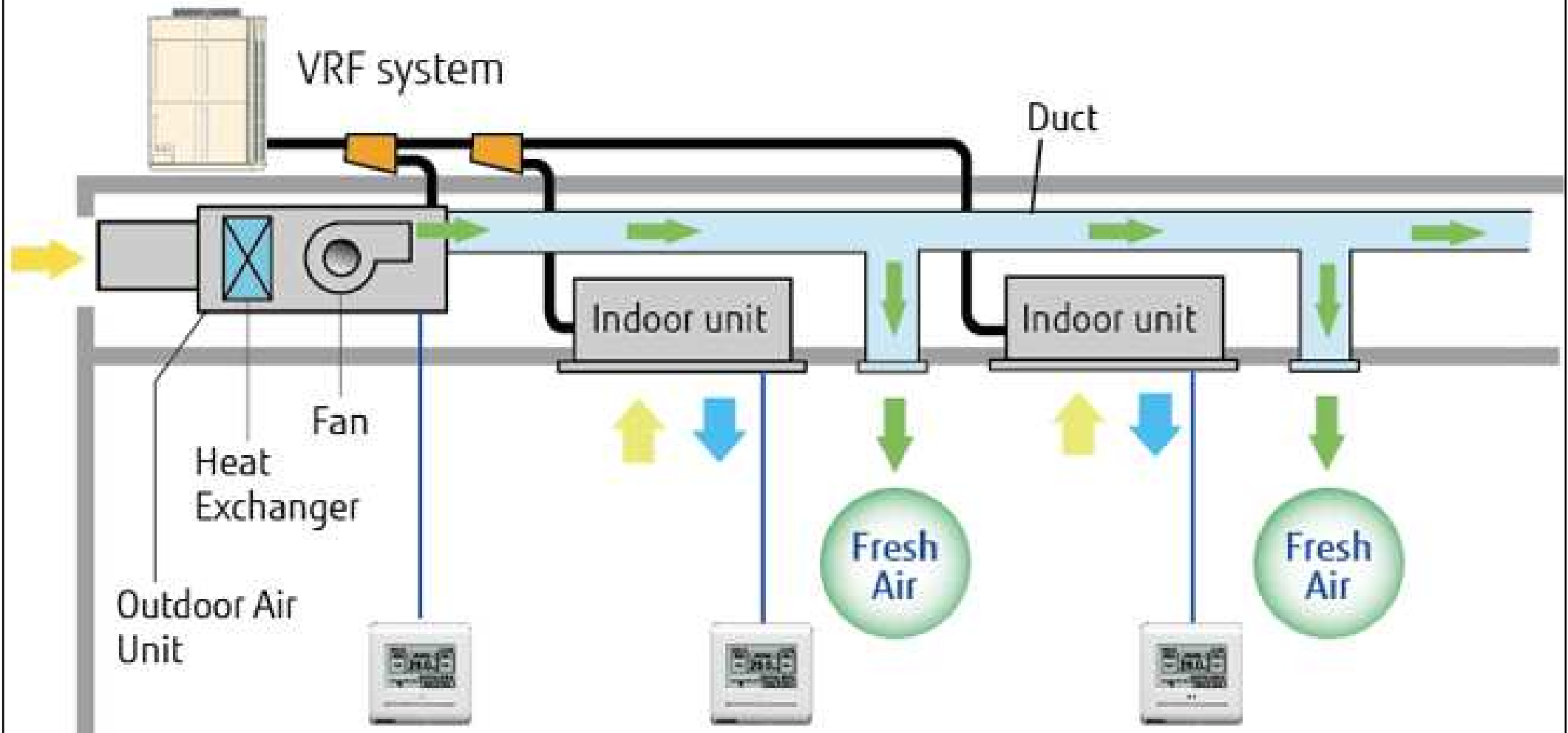



Design Issues

- Dedicated outdoor air system (DOAS)
 - If a DOAS is applied to a VRF system, the lower off-coil temperatures at the DOAS allow the DOAS to manage a significant proportion of the outdoor air's latent cooling load
 - This lets the indoor units of the VRF system manage the majority of sensible and latent cooling loads of the indoor air
 - Similar to a primary air unit (PAU) in a chiller system

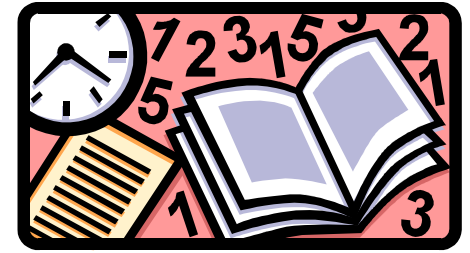

Further Reading

- ASHRAE Handbook 2016 HVAC Systems and Equipment
 - Chapter 18 – Variable Refrigerant Flow
- Back to basics: VRF systems
 - <http://www.csemag.com/single-article/back-to-basics-vrf-systems/>
- HVAC Variable Refrigerant Flow Systems
 - <http://www.seedengr.com/Variable%20Refrigerant%20Flow%20Systems.pdf>