

# **WELDING INSPECTION QUALIFICATIONS**

## **& TESTING PROCEDURES**

### **Contents:**

#### **I. INTRODUCTION**

#### **II - WELD INSPECTOR KNOWLEDGES:**

#### **III - WELDING SYMBOLS**

#### **IV - STANDARDS FOR WELDING POSITIONS**

#### **V – WELDING PROCESSES**

#### **VI. WELDING INSPECTION PROCEDURES**

#### **VII. NONDESTRUCTIVE TESTING (NDT)**

#### **VIII. DESTRUCTIVE TESTING**

#### **IX. WELDING ELECTRODES AND PREHEAT REQUIREMENTS**

#### **X. CLASSIFICATION OF ELECTRODES**

#### **XI. WELDING FAILURES**

#### **XII. WELDING TEST COUPON PROCEDURES**

#### **XIII. LEAK TESTING**

#### **XIV. WELDING EQUIPMENT**

#### **XVI. WELDING FOR JOISTS AND FINISHING OF MACHINING RAILS**

#### **XVI. BOILERMAKER**

#### **XVII. INSPECTION DUTIES**

#### **XVIII. STANDARD SPECIFICATIONS FOR WELDING PROCEDURES**

#### **XIX. INSPECTOR CERTIFICATIONS**

#### **XX. SAFETY AND PRECAUTIONS**

#### **XXI. WELDER QUALIFICATION RECORDS – SAMPLES**

## I – INTRODUCTION:

The main objective of this manual is to bring a resume of the most common subjects that generally matter in daily welding inspections, tailored for students, welders, technicians, welding inspectors and engineers in a practical way that anyone can research some subject in a timely manner to carry a work, without wasting too much his precious time.

Metallurgy is not the scope and is limited in selecting welding processes, materials, and inspection procedures for the common construction applications.

Weld inspection serves as a **quality control** on fabrication, welding operations and welding procedures. Records of how often various types of defects occur, must show when changes in welding procedures are necessary, detecting poor welding practices or when the welders or welding operators should be re-qualified.

The Welding Inspector must judge whether the weldments inspected are conform to the specifications and the quality criteria defined in drawings, applicable specifications and welding standards. The inspector must know the limitations of the testing methods, materials, basic metallurgy, heat-treatments, procedures and all types of fabrication processes.

Nondestructive personnel must be qualified according to ASNT (American Society for Nondestructive Testing) according to **ASNT SNT-TC-1A**. A responsible manufacturer depends entirely on inspection records to correct problems soon enough to prevent the lost time of frequent repairs.

## II - WELDING INSPECTOR KNOWLEDGES:

The Welding Inspector must be a high skilled technician or engineer with a good knowledge of general industry manufacture, materials, quality systems, inspection procedures and standards as:

- Standard organizations as ASTM, SAE, AISI, AWS, ASME and other institutions;
- Metals metallurgy, hardness tests and heat treatment;
- Materials properties, destructive testing and NDT methods;
- Terminology, weld joint geometry and welding symbols;
- Welding equipment, metal joining and cutting processes;
- Application of procedures, records, welding inspection and qualifications;
- Evaluation of weld and base metal discontinuities;
- Metric and conversion practices;
- Safe welding practices;

### 1. Standards and Specifications:

The professional and industrial organizations in the United States that lead the development of standards include: the ASTM International, the Society of Automotive Engineers (SAE), the American Iron and Steel Institution (AISI), the American Welding Society (AWS) and the ASME International.

Many specifications have also been developed by US government agencies such as the Department of Defense (DOD). However, the US government is revising its specification and many specifications are being controlled by diverse industrial groups.

The MIL-I-25135 has historically been the controlling document for military uses, but recent change in military specification management, was incorporated into SAE's AMS 2644. Thousands of standard specifications are recognized by the American National Standards Institute (ANSI), which is a national, private, coordinating agency.



The International Organization for Standardization (ISO) also performs this function, formed in 1947, as a non-governmental federation of standardization bodies from over 60 countries. The links of the specification organizations are indicated below:

### **American Society for Testing and Materials:**

ASTM standards: Founded in 1898, ASTM International is a not-for-profit organization that provides a global forum for the development and publication of voluntary consensus standards for materials, products, systems, and services.

The American Society for Testing and Materials, ASTM International provides standards that are accepted and used in research and development, product testing, quality systems, and commercial transactions around the globe.

Over 30,000 individuals from 100 nations are the members of ASTM International, who are producers, users, consumers, and representatives of government. In over 130 varied industry areas, ASTM standards serve as the basis for manufacturing, procurement, and regulatory activities.

Each year, ASTM publishes the Annual Book of ASTM Standards, which consists of approximately 70 volumes. Most of the NDT related documents can be found in Volume 03.03, Nondestructive Testing. E-03.03 is under the jurisdiction of ASTM Committee E-7.

Each standard practice or guide is the direct responsibility of a subcommittee. For example, document E-94 is the responsibility of subcommittee E07.01 on Radiology (x and gamma) Methods.

### **The Society of Automotive Engineers:**

SAE standards: The Society of Automotive Engineers is a professional society that serves as a resource for technical information used in designing, building, maintaining, and operating self-propelled vehicles for use on land or sea, in air or space.

Over 83,000 engineers, business executives, educators, and students from more than 97 countries form the memberships who share information for advancing the engineering of mobile systems. SAE is responsible for developing several different documents for the aerospace community.

These documents include: Aerospace Standards (AS), Aerospace Material Specifications (AMS), Aerospace Recommended Practices (ARP), Aerospace Information Reports (AIR) and Ground Vehicle Standards (J-Standards).

The documents are developed by SAE Committee K members, which are technical experts from the aerospace community.

### **American Society of Mechanical Engineers:**

ASME International was founded in 1880 as the American Society of Mechanical Engineers. It is a nonprofit educational and technical organization serving a worldwide membership of 125,000.

ASME Standards: ASME maintains and distributes 600 codes and standards used around the world for the design, manufacturing and installation of mechanical devices. One of these codes is called the Boiler and Pressure Vessel Code.

This code controls the design, inspection, and repair of pressure vessels. Inspection plays a big part in keeping the components operating safely. More information about the B&PV Code can be found at the links to the left.

### **The American Welding Society:**

The American Welding Society (AWS) was founded in 1919 as a multifaceted, nonprofit organization with a goal to advance the science, technology and application of welding and related joining disciplines.

#### AWS Standards:

AWS serves 50,000 members worldwide. Membership consists of engineers, scientists, educators, researchers, welders, inspectors, welding foremen, company executives and officers, and sales associates.

### **The International Organization for Standardization:**

The International Organization for Standardization (ISO) was formed in 1947 as a non-governmental federation of standardization bodies from over 60 countries.

#### ISO Standards:

The ISO is headquartered in Geneva, Switzerland. The United States is represented by the ANSI.

### **The Aerospace Industries Association:**

The Aerospace Industries Association represents the nation's major manufacturers of commercial, military and business aircraft, helicopters, aircraft engines, missiles, spacecraft, materials, and related components and equipment.

#### AIA Standards:

The AIA has been an aerospace industry trade association since 1919. It was originally known as the Aeronautical Chamber of Commerce (ACCA). The AIA is responsible for two NDT related documents, which are:

NAS 410, Certification & Qualification Of Nondestructive Test Personnel. This document is widely used in the aerospace industry as it replaces MIL-STD-410E.

Military Standard, Nondestructive Testing Personnel Qualification and Certification.  
NAS 999, Nondestructive Inspection of Advanced Composite Structure.

### **The American National Standards Institute:**

ANSI Standards: ANSI is a private, nonprofit organization that administers and coordinates the US voluntary standardization and conformity assessment system.

The Institute's mission is to enhance both the global competitiveness of US business and the US quality of life by promoting and facilitating voluntary consensus standards and conformity assessment systems, and safeguarding their integrity.

### **The American Society for Nondestructive Testing:**

ASNT Standards: The American Society for Nondestructive Testing offers certification in NDT, with membership over 12,000, including affiliation more than 500 companies. With ASNT comes access to thousands of NDT practitioners throughout the world working in manufacturing, construction, education, research, consulting, services and the military. NDT Certifications according to ASNT/SNT-TC-1A.

## 2. Materials – Fundamentals:

The structure of materials is classified by the general features being considered. The three most common major classification of structural, listed generally in increasing size, are:

- **Atomic structure:** includes features that cannot be seen, such as the types of bonding between the atoms, and the way the atoms are arranged;
- **Microstructure:** includes features that can be seen using a microscope, but seldom with the naked eye;
- **Macrostructure:** which includes features that can be seen with the naked eye)?

The atomic structure primarily affects the chemical, physical, thermal, electrical, magnetic, and optical properties. The microstructure and macrostructure can also affect these properties but they generally have a larger effect on mechanical properties and on the rate of chemical reaction.

From the periodic table, it can be seen that there are only about 100 different kinds of atoms in the entire Universe. These same 100 atoms form thousands of different substances ranging from the air we breathe to the metal used to support tall buildings.

1A	2A	Transition Elements										3A	4A	5A	6A	7A	8A	
1 H																	2 He	
2 Li	Be											B	C	N	O	F	Ne	
3 Na	Mg											Al	Si	P	S	Cl	Ar	
4 K	Ca	Sc	Ti	V	Cr	Mn	Fe	Co	Ni	Cu	Zn	Ga	Ge	As	Se	Br	Kr	
5 Rb	Sr	Y	Zr	Nb	Mo	Tc	Ru	Rh	Pd	Ag	Cd	In	Sn	Sb	Te	I	Xe	
6 Cs	Ba	La	Hf	Ta	W	Re	Os	Ir	Pt	Au	Hg	Tl	Pb	Bi	Po	At	Rn	
7 Fr	Ra	Ac	Rf	Db	Sg	Bh	Hs	Mt	Uun									
		Inner Transition Elements																
		Ce	Pr	Nd	Pm	Sm	Eu	Gd	Tb	Dy	Ho	Er	Tm	Yb	Lu			
		Th	Pa	U	Np	Pu	Am	Cm	Bk	Cf	Es	Fm	Md	No	Lr			

Metals behave differently than ceramics, and ceramics behave differently than polymers. The properties of matter depend on which atoms are used and how they are bonded together. The properties of a material offer clues as to the structure of the material. The strength of metals suggests that these atoms are held together by strong bonds. However, these bonds must also allow atoms to move since metals are also usually formable.

## 3. Basic Concepts of Materials Structure:

Thousands of materials available for use in engineering applications fall into one of three classes that are based on the atomic bonding forces of a particular material. These classifications are **metallic, ceramic and polymeric**.

Different materials can be combined to create a composite, further organized into groups based on their chemical composition or certain physical or mechanical properties.

These composite materials are grouped by combined types, the way the materials are arranged together. The list of some of the commonly classification of materials is:

### **a. Metallic:**

Ferrous metals and alloys - (irons, carbon steels, alloy steels, stainless steels, tool and die steels)  
Nonferrous metals and alloys - (aluminum, copper, magnesium, nickel, titanium, precious metals, refractory metals and super alloys).

### **b. Polymeric:**

Thermoplastics plastics  
Thermoset plastics  
Elastomers

### **c. Composites:**

Reinforced plastics  
Metal-matrix composites  
Ceramic-matrix composites  
Sandwich structures  
Concrete



**Obs.:** Other special materials as ceramics, glasses, glass ceramics, graphite, diamond, etc.

## **3.1. Physical and Chemical Properties:**

Physical properties can be observed without changing the identity of the substance. The general properties of matter such as color, density, hardness, are examples of physical properties.

Properties that describe how a substance changes into a completely different substance are called chemical properties. Flammability, corrosion, wear and oxidation resistance are examples of chemical properties in several types of alloys.

The difference between a physical and chemical property is straightforward until the phase of the material is considered. When a material changes from a solid to a liquid to a vapor it seems like them become a difference substance.

When a material melts, solidifies, vaporizes, condenses or sublimates, only the state of the substance changes. Phase is a physical property of matter in four phases – solid, liquid, gas and plasma.

## **3.2. Phase Transformation Temperatures:**

Density  
Specific Gravity  
Thermal Conductivity  
Linear Coefficient of Thermal Expansion  
Electrical Conductivity and Resistivity  
Magnetic Permeability  
Corrosion Resistance  
Wear Resistance

### 3.3. Metals:

Metals account for about two thirds of all the elements and about **24% of the mass of the planet**. Metals have useful properties including strength, ductility, high melting points and toughness. From the periodic table, it can be seen that a large number of the elements are classified as metal. A few of the common metals and their typical uses are presented below:

### 3.4. Common Metallic Materials:

**Iron/Steel** - Steel alloys are used for strength critical applications.

**Aluminum** - Aluminum and its alloys are used because they are easy to form, readily available, inexpensive, and recyclable.

**Copper** - Copper and copper alloys have a number of properties that make them useful, including high electrical and thermal conductivity, high ductility, and good corrosion resistance.

**Titanium** - Titanium alloys are used for strength in higher temperature ( $\sim 1000^{\circ}\text{F}$ ), when component weight is a concern, or when good corrosion resistance is required.

**Nickel** - Nickel alloys are used for still higher temperatures ( $\sim 1500\text{-}2000^{\circ}\text{F}$ ) or when good corrosion resistance is required.



### 3.5. Refractory Materials:

These materials are used for the highest temperature ( $> 2000^{\circ}\text{F}$ ) applications. The main feature that distinguishes metals from **non-metals** is their bonding. Metallic materials have **free electrons** that are free to move easily from one atom to the next.

The free electrons have a number of profound consequences for the properties of metallic materials. It is known that metallic materials tend to be good electrical conductors because the free electrons can move around within the metal so freely.

## 4. Steel Production:

Steel is an alloy of iron usually containing **less than 1.5% carbon**. Steel can be cast into bars, strips, sheets, nails, spikes, wire, rods or pipes as needed by the intended user. Steel production at an integrated steel plant involves **three basic steps**. First, the **heat source** used to melt iron ore is produced. Next the **iron ore** is melted in a furnace. Finally, the molten iron is processed to **produce steel**. The fuel source is often purchased from off-site producers.

Steel is made by the Bessemer, Siemens Open Hearth, Basic Oxygen Furnace, Electric Arc, Electric High-frequency and Crucible processes. In the former processes, molten pig iron is **refined** by blowing air through it in an egg-shaped vessel, known as a **converter**.

In the Siemens process, both acid and basic, the necessary **heat** for melting and working the charge is supplied by **oil or gas**.

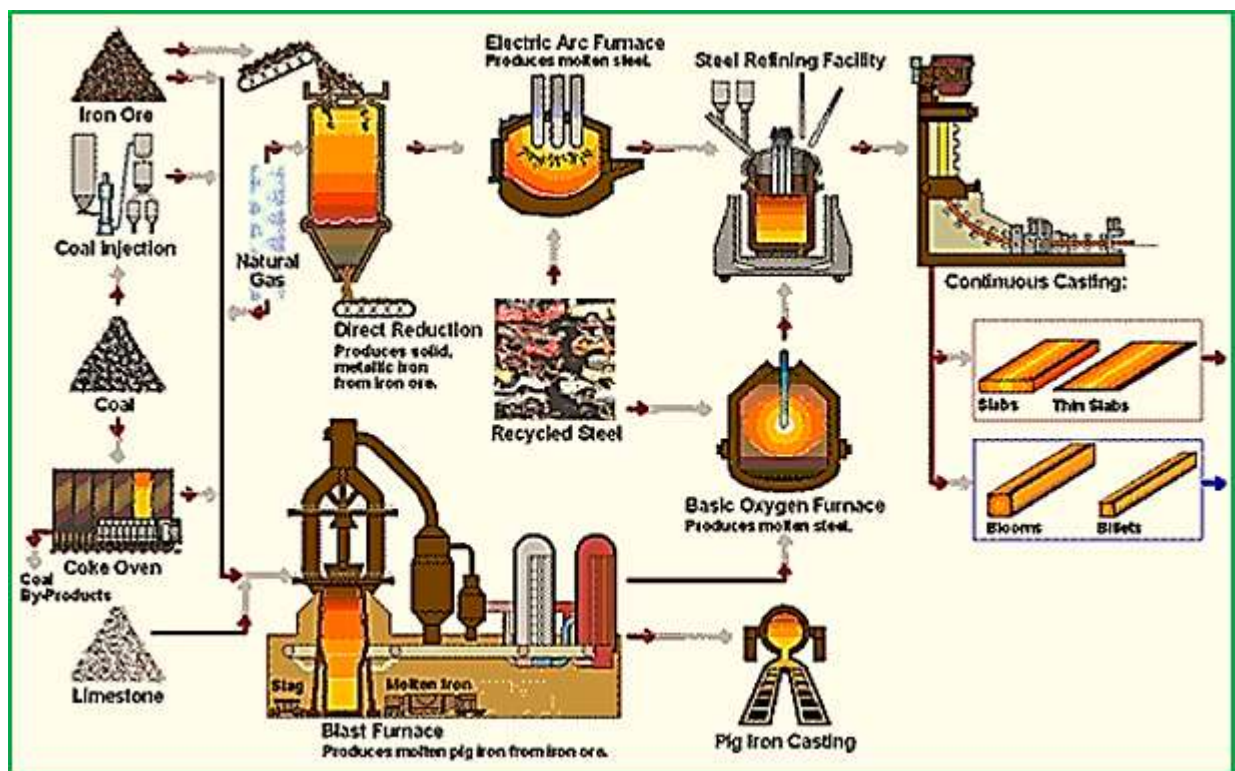

**Coke** is a solid carbon fuel and carbon source used to **melt and reduce iron ore**. Coke production begins with pulverized, bituminous coal, produced in batch processes, with multiple coke ovens operating simultaneously.

Heat is frequently transferred from one oven to another to reduce energy requirements. After the coke is finished, it is moved to a quenching tower where it is cooled with water spray. Once cooled, the coke is moved directly to an iron melting furnace or into storage for future use.

During **iron making**, **iron ore, coke, heated air and limestone or other fluxes are fed** into a blast furnace. The heated air causes the coke combustion, which provides the heat and carbon sources for iron production.

**Limestone** or other fluxes may be added to react with and remove the acidic impurities, called **slag**, from the molten iron. The limestone-impurities mixtures float to the top of the molten iron and are skimmed off, after melting is complete.



Sintering products may also be added to the furnace. Sintering is a process in which solid wastes are combined into a porous mass that can then be added to the blast furnace. These wastes include iron ore fines, pollution control dust, coke breeze, water treatment plant sludge, and flux.

Sintering plants help reduce solid waste by combusting waste products and capturing trace iron present in the mixture. Sintering plants are not used at all steel production facilities.

Molten iron from the blast furnace is sent to a basic oxide furnace, which is used for the final refinement of the iron into steel. High purity oxygen is blown into the furnace and combusts carbon and silicon in the molten iron. The basic oxide furnace is fed with fluxes to remove any final impurities and **alloy materials** may be added to enhance the **characteristics** of the steel.

The **resulting steel** is most **often cast into slabs, beams or billets**. Further shaping of the metal may be done at steel foundries, which re-melt the steel and pour it into molds, or at rolling facilities, depending on the desired final shape.

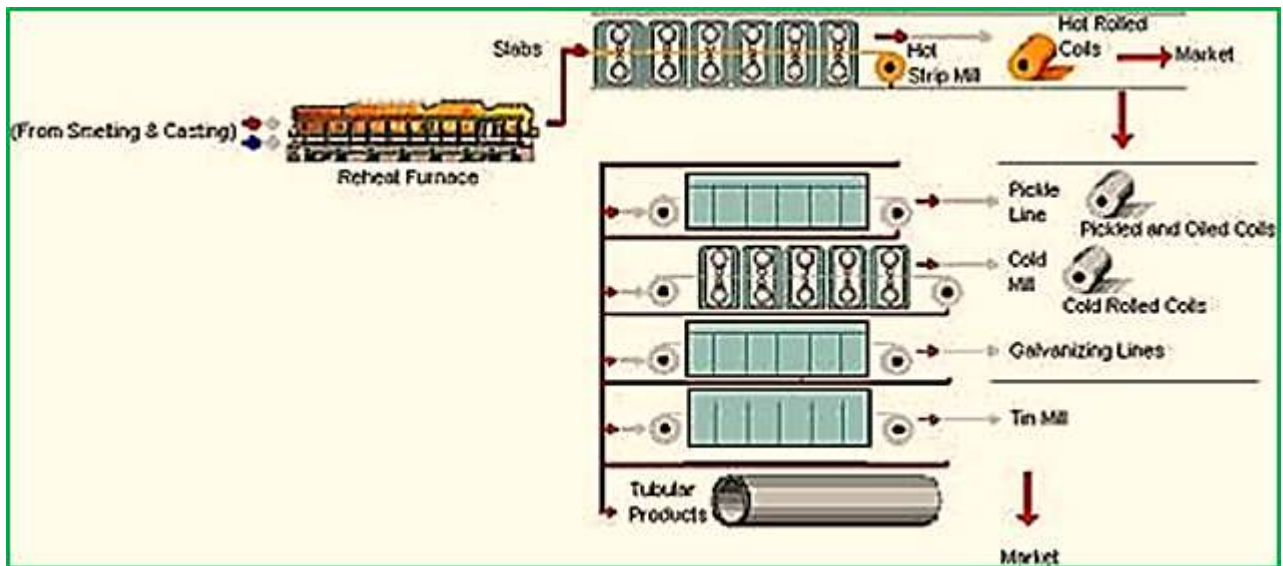

Coke production is one of the major pollution sources from steel production. Air emissions such as coke oven gas, naphthalene, ammonium compounds, crude light oil, sulfur and coke dust are released from coke ovens.

**Cokeless iron making** procedures are currently being studied and, in some places, implemented. One such procedure is the Japanese Direct Iron Ore Smelting (DIOS) process. The DIOS process produces molten iron from coal and previously melted ores. In this process, coal and other ores can produce enough heat to melt ore, replacing coke completely.

A final coke less iron melting process is the Corex or Cipcior Process. This process also manipulates coke to produce the heat required to melt iron. A Corex plant is operational in South Africa. Korea has a Corex plant operating at 70% capacity in 1996, expected to continue in progress.

The process integrates **coal desulfurization**, has flexible coal-type requirements, and generates excess electricity that can be sold to power grids. Further testing is being conducted in the U.S to determine commercial feasibility.

Iron carbide production plants are an alternative to the Basic Oxide Furnace. These plants use iron carbide, an iron ore that contains 6% carbon rather than 1.5-1.8% of regular iron ore. The additional carbon ignites in the presence of oxygen and contributes heat to the iron melting process, reducing energy requirements.

**Steelmaking from scrap metals** involves melting scrap metal, removing impurities and casting it into the desired shapes. Electric arc furnaces (EAF) are often used. The EAF's melt scrap metal in the presence of electric energy and oxygen.

The process does not require the three step refinement as needed to produce steel from ore. Production of steel from scrap can also be economical on a much smaller scale. Frequently mills producing steel with **EAF technology** are called mini-mills.

EOF was developed to replace the electric arc and other steelmaking furnaces. The Electric Oxygen Furnace (EOF) is an oxygen steelmaking process. Carbon and oxygen react to preheat scrap metal, hot metal and/or pig iron.

These furnaces **reduce capital and conversion costs**, energy consumption and environmental pollution, while increasing input flexibility.

After the molten metal is released from the BOF, EAF or EOF, it must be formed into its final shape and finished to prevent corrosion. Traditionally, steel was poured into convenient shapes called ingots and stored until further shaping was needed.

Current practices are continuous in casting methods, where the steel is **poured directly into semi-finished shapes**. Continuous casting saves time by reducing the steps required to produce the desired shape.

After the steel has **cooled in its mold**, continued shaping is done with hot or cold forming. Hot forming is used to make slabs, strips, bars or plates from the steel. Heated steel is passed between two rollers until it reaches the desired thickness.

#### **4.1 Metal Forming:**

**Cold forming** is used to produce **wires, tubes, sheets and strips**. In this process the steel is passed between two rollers, without being heated, to reduce the thickness. The steel is then heated in an annealing furnace to improve the ductile properties.

Cold rolling is more time consuming, but the products have better mechanical properties, better machinability, and can be more easily manipulated into special sizes and thinner gauges.

After rolling is completed, the steel pieces are **finished to prevent corrosion** and improve properties of the metal.

#### **4.2. Sheet Metal:**

Sheet metal is simply **metal formed into thin and flat pieces**. It is one of the fundamental forms used in metalworking, and can be cut and bent into a variety of different shapes. Thicknesses can vary significantly, although extremely thin thicknesses are considered **foil or leaf**, and pieces **thicker than 6 mm (0.25 in) are considered plate**.

Sheet metal is available in flat pieces or as a coiled strip. The coils are formed by running a continuous sheet of metal through a **roll slitter**. The thickness of the sheet metal is **called its gauge**.

Commonly used steel sheet metal ranges from **30 gauges to about 8 gauges**. The **larger** the gauge number, the **thinner** the metal.

Sheet metal also has applications in car bodies, airplane wings, medical tables, roofs for buildings (architectural) and many other things.

Sheet metal of iron and other materials with high magnetic permeability, also known as laminated steel cores has applications in transformers and electric machines. Below there is a simple representation of **metal transformation**.

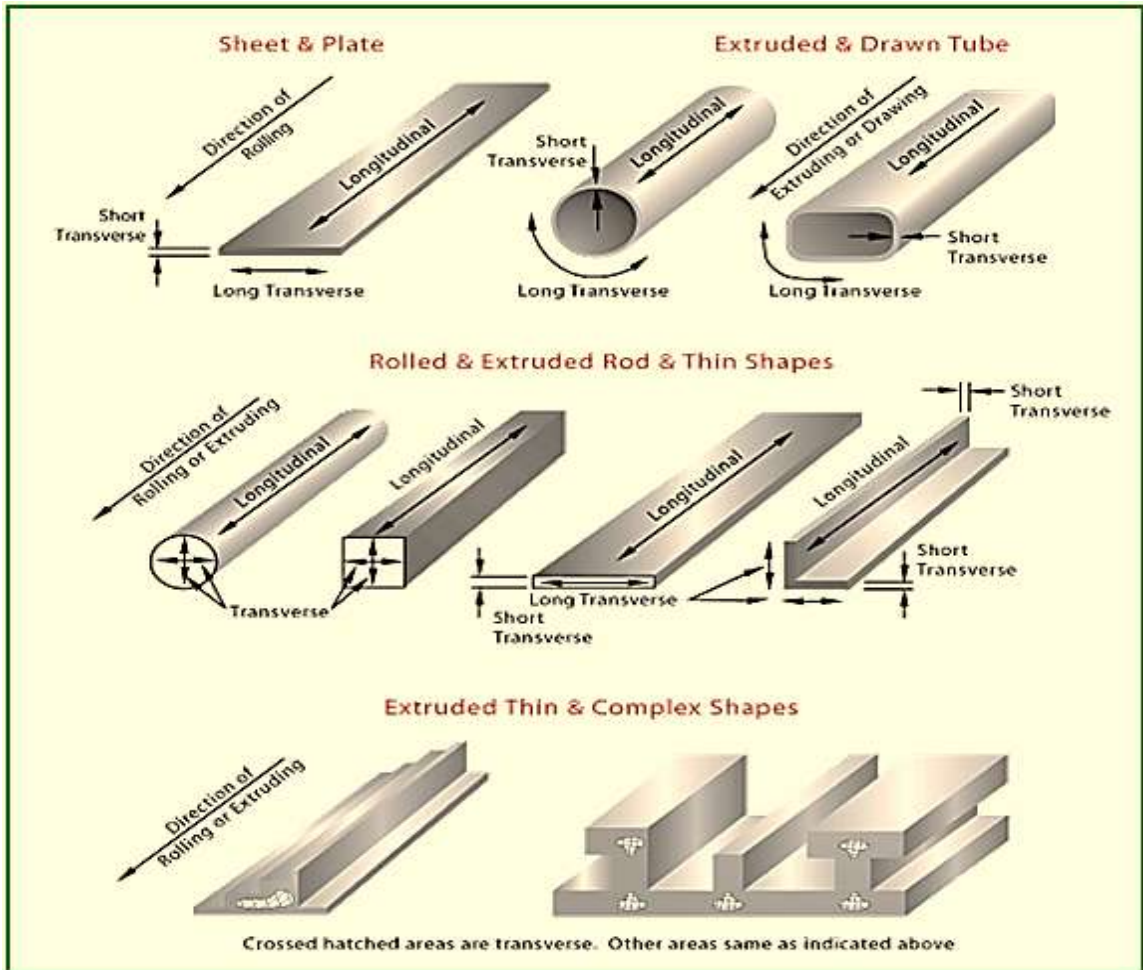

### 4.3. Steel Pipes Manufacturing:

Steel pipes, tubes or ducts are manufactured from **mild steel strips** are cut from **Hot Rolled Low Carbon Steel coils**, as shown below:

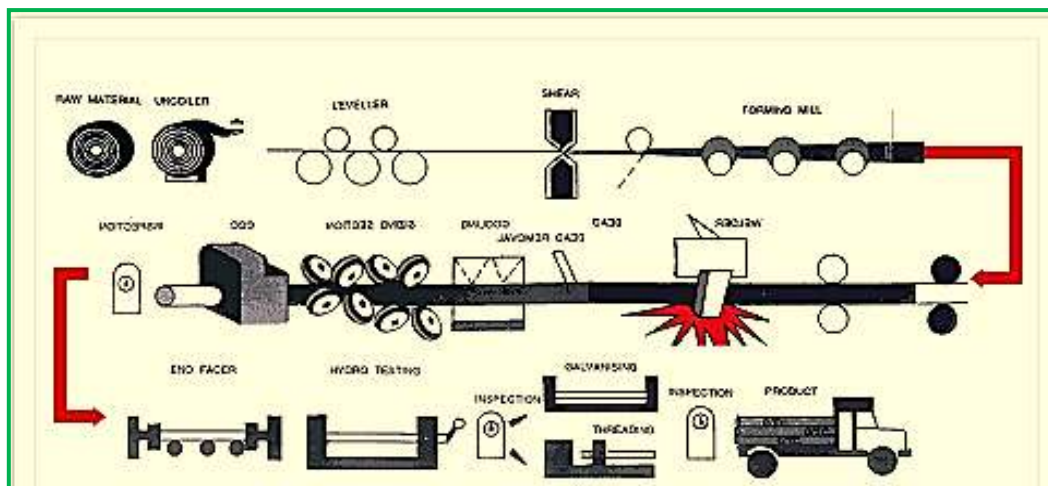

The strip passes through a series of drive forming and **fin rolls** and takes the **required circular shape** and is welded continuously by passage of an electric current of high frequency, i.e., **50,000 cycles/second** across the abutting edges.

The steel pipes tubes thus formed and welded pass through the sizing sections where dimensional deviations if any are corrected before the tubes are cut into required length by automatic cutting machines. The tubes are then **end deburred** and **pressure tested**.

Thereafter protective surface finishing operations such as Hot Dip Galvanizing or varnishing is done as per specific requirement. The tubes are offered as **plain, beveled, threaded ends** or with flanges.

#### 4.4. Foundry:

A foundry is a factory that produces **metal castings**. Metals are cast into shapes by melting them into a liquid, pouring the metal in a mold, and removing the mold material or casting after the metal has solidified as it cools.

The most common metals processed are **aluminum** and cast **iron**. Other metals, such as **bronze, steel, magnesium, copper, tin and zinc** are also used to produce castings in foundries.

Melting is performed in a **furnace mixing** virgin material, external scrap, internal scrap, and alloying elements to charge the furnace. Virgin material refers to commercially pure forms of the primary metal used to form a particular alloy.



Alloying elements are either pure forms of an alloying element, like electrolytic nickel or alloys of limited composition, such as ferroalloys or master alloys. External scrap is material from other forming processes such as punching, forging, or machining. Internal scrap consists of the gates, risers, or defective castings.

The process includes melting the charge, refining the melt, adjusting the melt chemistry and tapping into a transport vessel. Refining is done to remove deleterious gases and elements from the molten metal to avoid casting defects.

##### 4.4.1. Furnace:

Several specialized furnaces are used to melt the metal. Modern furnace types include Electric Arc Furnaces (EAF), induction furnaces, cupolas, reverberators, and crucible furnaces. Furnaces are **refractory lined vessels** that contain the material to be melted and provide the energy to melt it.

Furnace choice is dependent on the alloy system and quantities produced. Reverberators and crucible furnaces are common for producing aluminum castings. In the case of aluminium alloys, a degassing step is usually necessary to reduce the amount of hydrogen in the liquid metal.

If the hydrogen concentration in the melt is too high, the resulting casting will contain **gas porosity** that will deteriorate its mechanical properties. For low temperature melting point alloys, such as **zinc or tin**, melting furnaces may reach around **327° Celsius**. Electricity, propane, or natural gas is usually used for these temperatures.

For high melting point alloys such as **steel or nickel** based alloys, the furnace must be designed for temperatures over **1600° Celsius**. The fuel used to high temperatures can be electricity or coke.

#### 4.4.2. Mold Making:

In the casting process a **pattern** is made in the **shape** of the desired part. This pattern is made out of wax, wood, plastic or metal. Simple designs can be made in a single piece or solid pattern. More complex designs are made in two parts, called split patterns.

A split pattern has a top or upper section, called a cope, and a bottom or lower section called a drag. Both solid and split patterns can have cores inserted to complete the final part shape.

These mold processes include:

- **Sand casting** — Green or resin bonded sand mold.
- **Lost-foam casting** — Polystyrene pattern with a mixture of ceramic and sand mold.
- **Investment casting** — Wax or similar sacrificial pattern with a ceramic mold.
- **Ceramic mold casting** — Plaster mold.
- **V-process casting** — Vacuum is used in conjunction with thermoformed plastic to form sand molds. No moisture, clay or resin is needed for sand to retain shape.
- **Die casting** — Metal pattern.
- **Billet (ingot) casting** — Simple mold for producing ingots of metal normally for use in other foundries.

#### 4.4.3. Pouring:

In a foundry, molten metal is poured into molds. Pouring can be accomplished with gravity, or it may be assisted with a vacuum or pressurized gas.

Many modern foundries use robots or automatic pouring machines for pouring molten metal. Traditionally, molds were poured by hand using ladles.



#### 4.4.4. Finishing:

The final step in the process usually involves **grinding, sanding, or machining** the component in order to achieve the desired dimensional accuracies, physical shape and surface finish.

Removing the remaining gate material, called a gate stub, is usually done using a grinder or sanding. These processes are used because their material removal rates are slow enough to control the amount of material. These steps are done prior to any final machining.

After grinding, any surfaces that require **tight dimensional** control are **machined**. Many castings are machined in **CNC milling centers**. The reason for this is that these processes have better dimensional capability and repeatability than many casting processes.

Painting components to prevent corrosion and improve visual appeal is common. Some foundries will assemble their castings into complete machines or sub-assemblies. Other foundries weld multiple castings or wrought metals together to form a finished product.

#### 4.5. Forging:

Forging is a manufacturing process involving the **shaping of metal** using localized **compressive forces**. Forging is often classified according to the temperature: **"cold", "warm", or "hot" forging**.

Forged parts can range in weight from less than a kilogram to 580 metric tons. Forged parts usually require further processing to achieve a finished part.



Hot metal ingots being loaded into a hammer forge.

Some metals may be **forged cold**, but **iron and steel** are almost always **hot forged**. Hot forging prevents the work hardening that would result from cold forging, which would increase the difficulty of performing secondary machining operations on the piece.

While work hardening may be desirable in some circumstances, other methods of hardening the piece, such as heat treating, are generally more economical and more controllable. Alloys that are amenable to precipitation hardening, such as most aluminium alloys and titanium, can be hot forged, followed by hardening.

A forging press, often just called a press, is used for press forging. There are two main types, the mechanical and hydraulic presses:

**Mechanical presses** - function by using cams, cranks and/or toggles to produce a preset (a predetermined force at a certain location in the stroke) and reproducible stroke. Mechanical presses **are faster** than their hydraulic counterparts (up to 50 strokes per minute). Their capacities range from 300 to 18,000 short tons-force.

**Hydraulic presses** - use fluid pressure and a piston to generate force. The advantages of a hydraulic press over a mechanical press are its flexibility and greater capacity. The disadvantages include a slower, larger, and costlier machine to operate.

The roll forging, upsetting, and automatic hot forging processes all use specialized machinery.

#### 4.5.1. Wrought Iron:

Wrought iron is an iron alloy with very **low carbon content** in comparison to steel, and has fibrous inclusions, known as **slag**. This is what gives it a **"grain" resembling wood**, which is visible when it is etched or bent to the point of failure.

Wrought iron is tough, malleable, ductile and easily welded. Historically, it was known as "commercially pure iron", however, it no longer qualifies because current standards for commercially pure iron require a carbon content of less than 0.008 %.

Before the development of effective methods of steelmaking and the availability of large quantities of steel, wrought iron was the most common form of malleable iron. Demand for wrought iron reached its peak in the 1860s with the adaptation of ironclad warships and railways, but then declined as mild steel became more available.

A modest amount of wrought iron was used as a raw material for manufacturing of steel, which was mainly to produce **swords, cutlery, chisels, axes** and other edge tools, as well as, springs and files.

Wrought iron is no longer produced on a commercial scale. Many products described as wrought iron, such as guard rails, garden furniture and gates, are made of mild steel.

The items produced from wrought iron include rivets, nails, wire, chains, railway couplings, water and steam pipes, nuts, bolts, horseshoes, handrails, straps, roof trusses and ornamental ironwork.

Many structural metals undergo some special treatment to modify their properties, so that they will perform better for a different use. This treatment can include mechanical working, such as rolling or forging, alloying and/or thermal treatments.

As an example, commercially pure aluminum (1100) has a tensile strength of around 13,000 psi, which limits its usefulness in structural applications. However, by cold-working aluminum, its strength can be approximately doubled.

Strength increases are obtained by adding alloying metals such as manganese, silicon, copper, magnesium and zinc and many aluminum alloys are strengthened by heat treatment. Some heat-treatable aluminum alloys obtain tensile strengths that can exceed 100,000 psi.

#### 4.6. Alloying:

Only a few elements are widely used commercially in their pure form. Generally, other elements are introduced in the various forms of alloys, to produce **greater strength**, improve **corrosion resistance** or simply left as impurities from the refining process.

The addition of other elements into a metal is called alloying and the resulting metal is called an alloy. Even if the added elements are nonmetals, alloys may still have metallic properties.

Copper alloys were produced very early in our history. Bronze, an alloy of copper and tin, was the first alloy known. It was easy to produce by simply adding tin to molten copper. Tools and weapons made of this alloy were stronger than pure copper ones.

The typical alloying elements in some common metals are presented in the table below:

<b>Alloy</b>	<b>Composition</b>
Brass	Copper, Zinc
Bronze	Copper, Zinc, Tin
Pewter	Tin, Copper, Bismuth, Antimony.
Cast Iron	Iron, Carbon, Manganese, Silicon.
Steel	Iron, Carbon (plus small amounts of other elements)
Stainless Steel	Iron, Chromium, Nickel.

The properties of alloys can be manipulated by varying composition. Steel formed from iron and carbon can vary in hardness, depending on the amount of carbon added, the way it was processed and a second alloy element is added, two basically different structural changes are possible.

Solid solution strengthening occurs, when the atoms of the new element form a solid solution with the original element, but there is still only one phase.

The term 'phase' refers to that region of space occupied by a physically homogeneous material. The atoms of the new elements form a new second phase. The entire microstructure may change to this new phase or two phases may be present.

#### 4.7. Solid Solution Strengthening:

Solid solution strengthening involves the **addition of other metallic elements** that will dissolve in the **parent lattice** and cause distortions because of the difference in atom size between the parent metal and the solute metal.

Substitutions of impurity atoms are usually close in size (within approximately 15%) to the bulk atom. Interstitial impurity atoms are much smaller than the atoms in the bulk matrix and fit into the open space between the bulk atoms of the lattice structure.

Since the impurity atoms are **smaller or larger** than the surrounding atoms they introduce tensile or compressive lattice strains. They disrupt the regular arrangement of ions and make it more difficult for the layers to slide over each other.

This makes the alloy stronger and less ductile than the pure metal. For example, an alloy of **30% nickel** raises the **cast tensile strength** of copper from 25,000 psi to 55,000 psi.

#### 4.8. Multiphase Metals:

Another method of strengthening metals is adding elements that have no or partial solubility in the parent metal. The addition of **tin, zinc, or aluminum** to **copper** will result in an alloy with **increased strength**, but alloying with lead or bismuth will result in a lower strength alloy.

This will result in the appearance of a second phase distributed throughout the crystal or between crystals. However, secondary phases can **raise or reduce** the strength of an alloy. The properties of a polyphase (two or more phase) material depend on the nature, amount, size, shape, distribution, and orientation of the phases.

Phases can be seen on a **microscopic scale** with an optical microscope after the **surface** has been properly **polished and etched**. Greek letters are commonly used to distinguish the different solid phases in a given alloy.

Below is a **micrograph** take at **125x** of **lead-tin alloy** composed in two phases. The light colored regions are a tin-rich phase and the dark colored regions are a lead-rich phase.

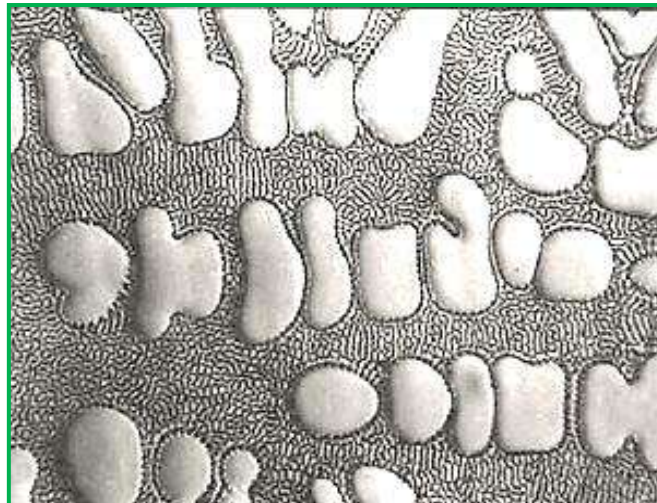

#### 4.9. Thermal Treatments (Heat-Treating):

Heat-treating is a term used to describe all of the controlled **heating and cooling operations** performed on a material in the solid state for the purpose of **altering its microstructure** and/or properties. The major objectives of the different kinds of thermal treatments are:

- Soften the material for improved workability.
- Increase the strength or hardness of the material.
- Increase the toughness or resistance to fracture of the material.



- Stabilize mechanical or physical properties against changes that might occur during exposure to service environments.
- Insure part dimensional stability.
- Relieve undesirable residual stresses induced during part fabrication.

Different metals respond to treatment at different temperatures. Each metal has a specific **chemical composition**, so changes in physical and **structural properties** take place at different and critical temperatures. Depending on the thermal treatment used, the **atomic structure** and/or microstructure of a material **may change** due to movement of dislocations, an increase or decrease in solubility of atoms, an increase in grain size, the formation of new grains of the same or different phase, a change in the crystal structure, and others mechanisms.

#### 4.9.1. Precipitation Hardening:

An approach often taken to develop alloys for strength is reaching an alloy with a structure that consists of particles (which impede dislocation movement) dispersed in a ductile matrix, obtained by choosing an alloy with a single phase at elevated temperature, but on cooling will precipitate another phase in the matrix.

A thermal process is developed to produce the desired distribution of precipitate in the matrix and when the alloy is strengthened by this thermal treatment, it is called **precipitation strengthening or hardening**.

Precipitation hardening consists of **three main steps**: solution treatment, quenching, and aging.

**Solution treatment** - involves heating the alloy to a temperature that allows the alloying atoms (called the solute) resulting in a homogeneous solid solution of one phase.

**Quenching** - rapidly cools the material so fast and freezes the atoms that the atoms of the alloying elements do not have time to diffuse out of the solution.

**Aging** - is the process where the solute particles diffuse out of the solution and into clusters that distort and strengthen the material.

The precipitation hardening process for a **copper-aluminum alloy** is **shown graphically** in the image below. The phase diagram is **simply a map** showing the structure of phases present, as the temperature and overall composition of the alloy are varied. The images on the right in the image show the resulting microstructure at each step in the process.

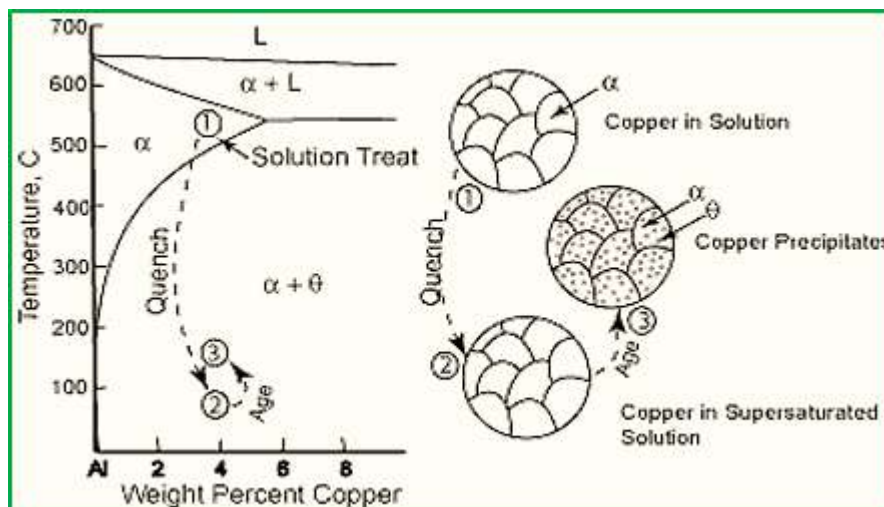

### 4.9.2. Common Heat-Treating Processes:

The more **common terms** used in worldwide industrial **heat-treating** are indicated below:

**Age Hardening** - is a relatively low-temperature heat treatment process that strengthens a material by causing the precipitation of components or phases of alloy from a super-saturated solid solution.

**Annealing** - is a softening process in which metals are heated and then allowed to cool slowly. The purpose of annealing is to soften the material for improve machinability, formability, and sometimes to control magnetic properties.

**Normalizing** - is much like annealing, but the cooling process is much faster. This result is increased strength but less ductility in the metal. Its purpose is to refine grain structure, produce more uniform mechanical properties, and sometimes to relieve internal and surface stresses.

**Precipitation Heat-Treatment** - is the three step process of solution treating, quenching, and age hardening to increase the strength or hardness of an alloy.

**Solution Heat-Treatment** - involves heating the material to a temperature that puts all the elements in solid solution and then cooling very rapidly to freeze the atoms in place.

**Stress Relieving** - is a low temperature heat treat process that is used to reduce the level of residual stresses in a material.

**Tempering** - involves gently heating a hardened metal and allowing it to cool slowly will produce a metal that is still hard but also less brittle. This process is known as tempering.

**Quenching** - is the rapid cooling of a hot material. The medium used to quench the material can vary from forced air, oil, water and others. Many steels are hardened by heating and quenching. Quenching results in a metal that is very hard, but also brittle.

### 5. Density:

The space the mass occupies is its volume, and **the mass per unit of volume is its density**. Mass (**m**) is a fundamental measure of the amount of matter. Weight (**w**) is a measure of the force exerted by a mass and this force is produced by the acceleration of gravity.

Mathematically, density is defined as mass divided by volume:

$$\rho = \frac{m}{V},$$

Where,

**ρ** is the density, **m** is the mass, and **V** is the volume.

Mass density is a unit of mass per unit of volume. As there are many units of mass and volume covering many different magnitudes there are a large number of units for mass density in use.

Therefore, on the surface of the earth, the mass of an object is determined by dividing the weight of an object by  $9.8 \text{ m/s}^2$  ( $\sim 32 \text{ ft/s}^2$ ), the acceleration of gravity.

The **SI units** for density are **kg/m<sup>3</sup>**. The **imperial (U.S.)** units are **lb/ft<sup>3</sup>** or **slugs/ft<sup>3</sup>**.

Example of **water density** at:

<b>Temperature</b> (°F) (°C)	<b>Density</b> (lb/ft <sup>3</sup> ) (kg/m <sup>3</sup> )
32 (0)	62.418 (0.998)
40 (4,4)	62.426 (0.999)

**OBS.:** While people often use pounds per cubic foot as a measure of density in the U.S., **pounds are really measures of force, not mass. Slugs** are the **correct measure of mass**. You can multiply slugs by 32.2 for a rough value in pounds.

**Example:** Maximum density of water at 4°C (39.2 °F) = 1,000 kg/m<sup>3</sup> ~ 1.940 slugs/ft<sup>3</sup>.

Densities for some materials at atmospheric temperature:

<b>Material</b>	<b>Density</b>	
	(lb/ft <sup>3</sup> )	(kg/m <sup>3</sup> )
Clay, dry	100	1600
Clay, wet	110	1760
Gravel, dry	105	1680
Gravel, Wet	125	2000
Limestone	160	2560
Sand, dry	97	1555
Sand, wet	119	1905

## 6. Specific Gravity (SG):

Specific Gravity is the **ratio of density** of a substance compared **to the density of fresh water** at 4°C (39.2° F). At this temperature the density of water is 1000 kg/m<sup>3</sup> (62.4 lb/ft<sup>3</sup>) or 1.0 kg/cm<sup>3</sup>.

Then the Specific Gravity is the same, unity = 1.0. The Specific Gravity is a ratio, so **it has no units**.

### Example:

If the density of iron is 7850 kg/m<sup>3</sup> - then, the **Specific Gravity of iron** is:

$$SG = (7850 \text{ kg/m}^3) / (1000 \text{ kg/m}^3) =$$

**SG = 7.85**

Specific gravity values for a few common substances are: Au, 19.3; mercury, 13.6; alcohol, 0.7893; benzene, 0.8786.

An object will **float in water** if its density is **less than the density of water** and sink if its density is greater than that of water. Similarly, an object with specific gravity **less than 1.0 will float** and those with a specific gravity greater than one will sink.

## 7. Corrosion:

Corrosion involves the **deterioration of a material** as it reacts with its environment. Corrosion is the primary means by which metals deteriorate. Corrosion literally consumes the material reducing load carrying capability and causing stress concentrations.

The corrosion process is usually electrochemical in nature, having the essential features of a battery. Corrosion is a natural process that commonly occurs because unstable materials, such as refined metals want to return to a more stable compound.

For example, some metals, such as gold and silver, can be found in the earth in their natural, metallic state and they have little tendency to corrode. Iron is a moderately active metal and corrodes readily in the presence of water. The natural state of **iron is iron oxide** and the most common iron ore is **Hematite** with a chemical composition of **Fe<sub>2</sub>O<sub>3</sub>**. **Rust**, the most common corrosion of iron, also has a composition of **Fe<sub>2</sub>O<sub>3</sub>**.

**Corrosion** involves two chemical processes: **Oxidation and Reduction Reaction:**

**Oxidation** - is the process of stripping electrons from an atom and reduction occurs when an electron is added to an atom. The oxidation process takes place at an area known as the anode.

Positively charged atoms leave the solid surface of the anode, and enter into an electrolyte (may be water) as ions. The ions leave their corresponding negative charge in the form of electrons in the metal which travel to the location of the cathode through a conductive path.

**Reduction Reaction** - takes place at the corresponding cathode, and consumes the free electrons. The electrical balance of the circuit is restored at the cathode when the electrons react with neutralizing positive ions, such as hydrogen ions, in the electrolyte.

From this description, it can be seen that there are four essential components that are needed for a corrosion reaction to proceed. These components are an anode, a cathode, an electrolyte with oxidizing species, and some direct electrical connection between the anode and cathode.

Although atmospheric air is the most common environmental electrolyte, natural waters, such as seawater rain, as well as man-made solutions, are the environments most frequently associated with corrosion problems.

**Aluminum** is a relatively reactive metal; among structural metals, only beryllium and magnesium are more reactive. Aluminum owes its excellent corrosion resistance to the barrier oxide film that is bonded strongly to the surface, and if damaged, reforms immediately in most environments. On a surface freshly abraded and exposed to air, the protective film is only 10 Angstroms thick but highly effective at protecting the metal from corrosion.

## 8. Mechanical Properties:

The mechanical properties of a material are those properties that involve a **reaction to an applied load**. The mechanical properties of metals determine the range of usefulness of a material and establish the service life that can be expected. Mechanical properties are also used to help classify and identify material. The most common properties considered are strength, ductility, hardness, impact resistance, and fracture toughness.

Most structural materials are **anisotropic**, which means that their material **properties vary with orientation**. The variation in properties can be due to directionality in the microstructure (texture) from forming or cold working operation, the controlled alignment of fiber reinforcement and a variety of other causes.

Mechanical properties are generally specific to product form such as sheet, plate, extrusion, casting, forging, and etc. Additionally, it is common to see mechanical property listed by the directional grain structure of the material.

In products such as sheet and plate, the rolling direction is called the longitudinal direction, the width of the product is called the transverse direction, and the thickness is called the short transverse direction. The grain orientations in standard wrought forms of metallic products are shown the image.

### 8.1. Loading:

The application of a force to an object is known as loading. Materials can be subjected to many different loading scenarios and a material's performance is dependent on the loading conditions.

There are **five** fundamental **loading** conditions: tension, compression, bending, shear, and torsion:

- **Tension** - is the type of loading in which the two sections of material on either side of a plane tend to be pulled apart or elongated.
- **Compression** - is the reverse of tensile loading and involves pressing the material together.
- **Bending** - is a load in a manner that causes a material to curve and results in compressing the material on one side and stretching it on the other.
- **Shear** - is a load parallel to a plane which caused the material on one side of the plane to want to slide across the material on the other side of the plane.
- **Torsion** - is the application of a force that causes twisting in a material.

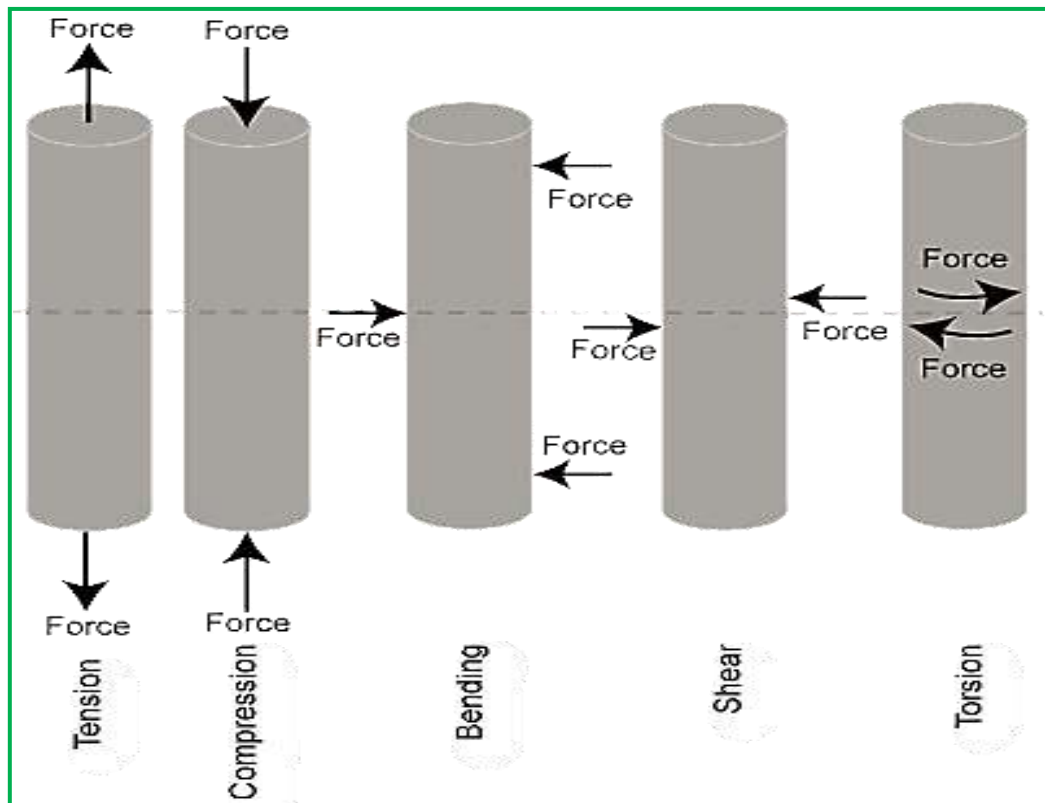

**Static loading** – is a material subjected to a constant force.

**Dynamic or cyclic loading** – is a not constant loading of the material, but instead fluctuates. The way a material is loaded greatly affects its mechanical properties and largely determines how, or if, a component will fail; and whether it will show warning signs before failure actually occurs.

## 8.2. Stress and Strain:

**Stress** - is the applied force or system of forces that tends to deform a body. The term stress is used to express the loading in terms of **force applied** to a certain cross-sectional area of an object. Stress is also the internal distribution of forces within a body that balance and react to the loads applied to it. The stress distribution may or may not be uniform, depending on the nature of the loading.

For example, a bar loaded in pure tension will essentially have a uniform tensile stress distribution. However, a bar loaded in bending will have a stress distribution that changes with distance perpendicular to the normal axis.

The word "**vector**" typically refers to a quantity that has a "**magnitude**" and a "**direction**". For example, the stress in an axially loaded bar is simply equal to the applied force divided by the bar's cross-sectional area.

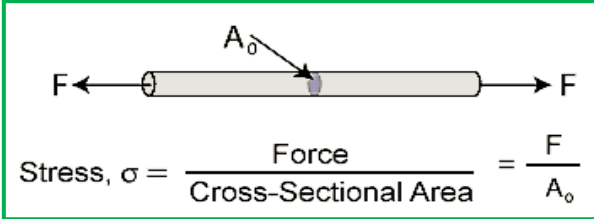
$$\text{Stress, } \sigma = \frac{\text{Force}}{\text{Cross-Sectional Area}} = \frac{F}{A_0}$$

Some common measurements of stress are:

**psi** = lbs./in<sup>2</sup> (pounds per square inch);

**ksi** or **kpsi** = kilopounds/in<sup>2</sup> (one thousand or 10<sup>3</sup> pounds per square inch);

**Pa** = **N/m<sup>2</sup>** (Pascal or Newton per square meter);

**kPa** = Kilopascals (one thousand or 10<sup>3</sup> Newton per square meter);

**GPa** = Gigapascal (one million or 10<sup>6</sup> Newton per square meter).

\*Any metric prefix can be added in front of psi or Pa to indicate the multiplication factor.

## 8.3. Tensile Properties:

Tensile properties indicate how the material will react to forces being applied in tension. A tensile test is a fundamental **mechanical test** where a carefully prepared specimen is loaded in a tensile machine. After the test is measured the elongation of the specimen over the reached distance.

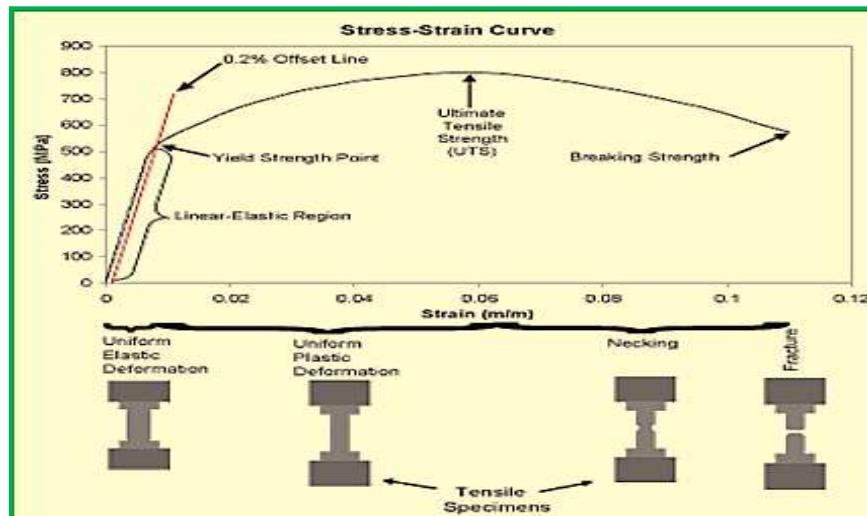

A typical engineering **stress-strain curve** is shown above. If the true stress, based on the actual cross-sectional area of the specimen, is used, it is found that the stress-strain curve increases continuously up to fracture.

Tensile tests are used to determine the modulus of elasticity, elastic limit, elongation, proportional limit, reduction in area, tensile strength, yield point, yield strength and other tensile properties. As can be seen, the main product of a tensile test is a **load versus elongation curve** which is then converted into a stress versus strain curve.

Since both the engineering stress and the engineering strain are obtained by dividing the load and elongation by constant values (specimen geometry information), the load-elongation curve will have the same shape as the engineering stress-strain curve.

#### 8.4. Linear-Elastic Region and Elastic Constants:

As can be seen in the figure, the **stress and strain** initially increase with a linear relationship and it indicates that no plastic deformation has occurred. In this region of the curve, when the stress is reduced, the material will return to its original shape.

The line obeys the relationship defined as **Hooke's Law** where the ratio of stress to strain is a constant. The slope of the line in this region where stress is proportional to strain and is called the **Modulus of Elasticity** or **Young's Modulus**.

The **Modulus of Elasticity (E)** defines the properties of a material as it undergoes stress, deforms, and then returns to its original shape after the stress is removed. It is a measure of the stiffness of a given material.

Axial strain is always accompanied by lateral strains of opposite sign in the two directions mutually perpendicular to the axial strain. Strains that result from an increase in length are designated as positive (+) and those that result in a decrease in length are designated as negative (-).

**Poisson's ratio** is defined as the negative of the ratio of the lateral strain to the axial strain for a uniaxial stress state. *Poisson's ratio* is sometimes also defined as the ratio of the absolute values of lateral and axial strain. This ratio, like strain, is **unitless** since both strains are unitless.

$$\nu = -\frac{\epsilon_{lateral}}{\epsilon_{axial}}$$

For stresses within the elastic range, this ratio is approximately constant. For a perfectly isotropic elastic material, **Poisson's Ratio is 0.25**, but for most materials the value lies in the range of 0.28 to 0.33. For steels, Poisson's ratio will have a value of approximately 0.3. Only two of the elastic constants are independent so if two constants are known, the third can be calculated using the following formula:

$$E = 2(1 + \nu)G =$$

**Where:**

- E = Modulus of Elasticity (Young's modulus);
- $\nu$  = Poisson's Ratio;
- G = Modulus of Rigidity (shear modulus).

The relationship between the change in pressure and the resulting strain produced is the bulk modulus. **Lame's** constants are derived from Modulus of Elasticity and Poisson's ratio.

## 8.5. Yield Point:

In ductile materials, at some point, the stress-strain curve deviates from the straight-line relationship and Law no longer applies as the strain increases faster than the stress. In brittle materials, little or no plastic deformation occurs and the material fractures near the linear-elastic portion of the curve.

From this point on in the tensile test, some permanent deformation occurs in the specimen and the material is said to react plastically to any further increase in load or stress. The material will not return to its original, unstressed condition when the load is removed.

With most materials there is a gradual transition from elastic to plastic behavior, and the exact point at which plastic deformation begins to occur is hard to determine. The yield strength is defined as the stress required produces a small, amount of plastic deformation.

The **offset yield strength** is the stress corresponding to the intersection of the stress-strain curve and a line parallel to the elastic part of the curve offset by a specified strain (in the US the offset is typically 0.2% for metals and 2% for plastics). A good way of looking at offset yield strength is that after a specimen has been loaded to its **0.2 percent offset** yield strength and then unloaded it will be 0.2 percent longer than before the test.

Some materials such as gray cast iron or soft copper exhibit essentially no linear-elastic behavior. For these materials the usual practice is to define the yield strength as the stress required to produce some total amount of strain.

**True elastic limit** - is a very low value and is related to the motion of a few hundred dislocations. Micro strain measurements are required to detect strain on order of  $2 \times 10^{-6}$  in/in.

**Proportional limit** - is the highest stress at which stress is directly proportional to strain. It is obtained by observing the deviation from the straight-line portion of the stress-strain curve.

**Elastic limit** - is the greatest stress the material can withstand without any measurable permanent strain remaining on the complete release of load. With the sensitivity of strain measurements usually employed in engineering studies ( $10^{-4}$ in/in), the elastic limit is greater than the proportional limit.

**Yield strength** - is the stress required to produce a small-specified amount of plastic deformation. The yield strength obtained by an offset method avoids the practical difficulties of measuring the elastic limit or proportional limit.

## 8.6. Ultimate Tensile Strength:

The ultimate tensile strength (UTS) of a material is its capacity to withstand external forces without breaking. The tensile strength, is the maximum stress level reached in a tension test.

In **brittle materials**, the ultimate tension goes at the end of the linear-elastic portion of the stress-strain curve or close to the elastic limit. The design of a component, may be based on the material tensile strength.

In **ductile materials**, the stress will continue to increase until fracture occurs. The current design practice is **to use the yield strength for sizing static components** both for specifying a correct material and for quality control purposes.

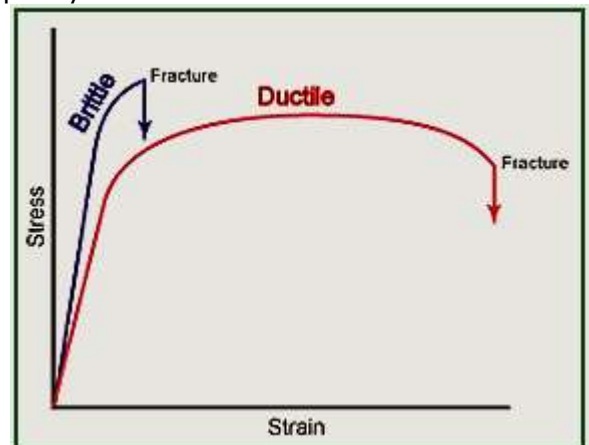



### 8.6.1. Measures of Ductility (Elongation and Reduction of Area):

The ductility of a material is a **measure of the extent** to which a material **will deform** before fracture. The amount of ductility is an important factor when considering forming operations such as rolling and extrusion.

The conventional measures of ductility are the engineering strain at fracture (usually called the elongation) and the reduction of area at fracture. It also provides an indication of how visible overload damage to a component might become before the component fractures.

**Elongation** is the change in axial length divided by the original length of the specimen or portion of the specimen. It is expressed as a percentage.

### 8.6.2. Compressive, Bearing, & Shear Properties:

In theory, the **compression test** is simply the **opposite of the tension test** with respect to the direction of loading. In compression testing the sample is squeezed while the load and the displacement are recorded. Compression tests result in mechanical properties that include the compressive yield stress, compressive ultimate stress, and compressive modulus of elasticity.

Compressive yield stress is measured in a manner identical to that done for tensile yield strength. When testing metals, it is defined as the stress corresponding to **0.002 in./in.** plastic strain.

For plastics, the compressive yield stress is measured at the point of permanent yield on the stress-strain curve. Moduli are generally greater in compression for most of the commonly used structural materials.



The **ultimate compressive strength** is the stress required to **rupture a specimen**. This value is much harder to determine for a compression test than it is for a tensile test since many material do not exhibit rapid fracture in compression.

Materials such as most plastics that do not rupture can have their results reported as the compressive strength at a specific deformation such as 1%, 5%, or 10% of the sample's original height.

For some materials, such as **concrete**, the **compressive strength** is the **most important** material property that engineers use when designing and building a structure. Compressive strength is also commonly used to determine whether a concrete mixture meets the service requirements.

### 8.7. Bearing Properties:

Bearing properties are used in **mechanically fastened joints**. The purpose of a bearing test is to determine the **deformation of a hole** as a function of the applied bearing stress.

The test specimen is basically a piece of sheet or plate with a carefully prepared hole some standard distance from the edge. Edge-to-hole diameter ratios of 1.5 and 2.0 are common. A hardened pin is **inserted through the hole** and an **axial load applied** to the specimen and the pin.

The bearing stress is computed by dividing the load applied to the pin, which bears against the edge of the hole, by the bearing area (the product of the pin diameter and the sheet or plate thickness).

Bearing yield and ultimate stresses (BYS) are obtained from bearing tests. **BYS** is computed from a bearing stress deformation curve by drawing a line parallel to the initial slope at an offset of 0.02 times the pin diameter. **BUS** is the maximum stress withstood by a bearing specimen.

## 8.8. Shear Properties:

A shearing stress acts **parallel to the stress plane**, whereas a tensile or compressive stress acts normal to the stress plane. Shear properties are primarily used in the design of mechanically fastened components, webs, and torsion members, and other components subject to parallel, opposing loads.

Shear properties are dependent on the type of shear test and there is a variety of different standard shear tests that can be performed including the **single-shear test, double-shear test, blanking-shear test, torsion-shear test** and others.

The **shear modulus of elasticity** is considered a basic shear property. Other properties, such as the proportional limit stress and shear ultimate stress, cannot be treated as basic shear properties because of "form factor" effects.

## 9. Hardness:

Hardness is the resistance of a material to localized deformation. The term can apply to **deformation from indentation, scratching, cutting or bending**. In metals, ceramics and most polymers, the deformation considered is plastic deformation of the surface.

For **elastomers** and some polymers, **hardness is defined at the resistance to elastic deformation** of the surface.

The lack of a fundamental definition indicates that **hardness is not a basic property** of a material, but rather a composite one with contributions from the yield strength, work hardening, true tensile strength, modulus, and others factors.

Hardness measurements are widely used for the **quality control of materials** because they are quick and considered to be nondestructive tests when the marks or indentations produced by the test are in low stress areas.

There are a large variety of **methods used for determining** the hardness of a substance, as can be seen below:

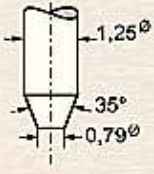
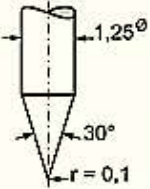
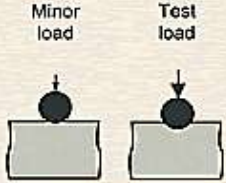
Process	Shore A	Shore D	Ball Hardness	Rockwell Hardness
Standards	ISO 868 DIN 53 505	ISO 868 DIN 53 505	ISO 2039-1 DIN 53 456	ISO 2039-2
Indenter	Truncated cone 	Cone 	Ball 5 mm Ø 	Ball Scale M: 6,35 mm Scale R: 12,7 mm Measures only permanent deformation, as measurement is done after removal of load
Test load	9,81 N	49,05 N	Steps for test load 49, 132, 358, 961 N depending on hardness	Scale M: 980 N Scale R: 588 N
Holding time	15 s	15 s	30 s	15 s
Uses	Soft elastomers, very soft thermoplastics	Hard elastomer, soft thermoplastics	Thermoplastics	Thermoplastics

The **most common methods** are indicated below:

## 9.1. Mohs Hardness Test:

One of the oldest ways of measuring hardness was devised by the German mineralogist **Friedrich Mohs** in 1812. The Mohs hardness test involves observing whether a materials surface is **scratched by a substance** of known or defined hardness. The numerical values to these physical properties are the **minerals, ranked** along with **Mohs scale**, composed of **10 minerals** that have been given arbitrary hardness values.

Mohs hardness test, facilitate the identification of minerals in the field, but is not suitable for accurately gauging the hardness of industrial materials such as steel or ceramics. For engineering materials, a variety of instruments have been developed over the years to provide a precise measure of hardness. Many apply a load and measure the depth or size of the resulting indentation. Hardness can be measured on the macro-, micro- or nano- scale.

Mohs Scale of Hardness			
1 - TALC - 1		6 - FELDSPAR - 72	
2 - GYPSUM - 2		7 - QUARTZ - 100	
3 - CALCITE - 9		8 - TOPAZ - 200	
4 - FLUORITE - 21		9 - CORUNDUM - 400	
5 - APATITE - 48		10 - DIAMOND - 1600	

## 9.2. Brinell Hardness Test:

The **oldest of the hardness test methods** in common use on engineering materials today is the Brinell hardness test, invented by **Dr. J. A. Brinell in Sweden in 1900**. The Brinell test uses a desktop machine to apply a specified load with a hardened sphere of a specified diameter.

The Brinell hardness number, or simply the **Brinell number**, is obtained by dividing the load used (kg or pounds) by the measured surface area of the indentation, (in square millimeters or square pounds), left on the test surface.

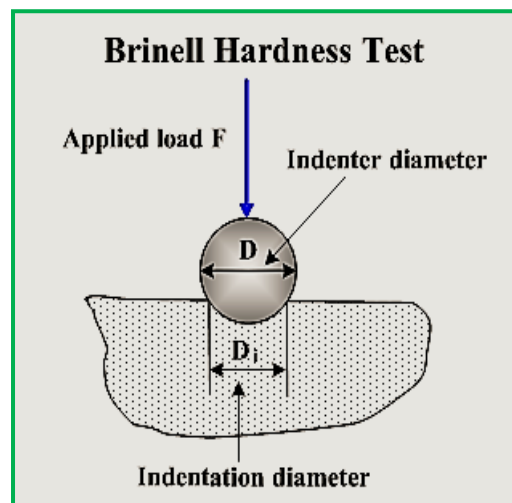
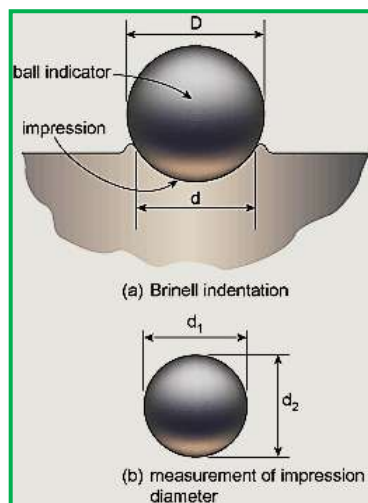

The Brinell test is frequently used to **determine the hardness metal forgings and castings** that have a large grain structures. The Brinell test provides a measurement over a fairly large area that is less affected by the coarse grain structure of these materials than are Rockwell or Vickers tests.

A wide range of materials can be tested using a Brinell test simply **by varying the test load and indenter ball size**. Brinell testing is typically done on **iron and steel castings** using a 3000 Kg test force and a 10 mm diameter ball. A 1500 kilogram load is usually used for aluminum castings.

Copper, brass and thin stock are frequently tested using a 500 Kg test force and a 10 or 5 mm ball. In Europe Brinell testing is done using a much wider range of forces and ball sizes and it is common to perform Brinell tests on small parts using a 1 mm carbide ball and a test force as low as 1 kg.

The low load tests are commonly referred to as baby Brinell tests. A value reported as **"60 HB 10/1500/30"** means that a Brinell Hardness of 60 was obtained using a 10 mm diameter ball with a 1500 kilogram load applied for 30 seconds.

### 9.3. Rockwell Hardness Test:

The Rockwell hardness test also uses a machine to apply a specific load and then measure the depth of the resulting impression. The **indenter** may either be a steel ball of some specified diameter or a spherical diamond-tipped **cone of 120° angle and 0.2 mm tip radius**, called **brale**.

A **minor load of 10 kg** is first applied, which causes a **small initial penetration** to seat the indenter and remove the effects of any surface irregularities. Then, the **dial is set to zero** and the major load is applied. Upon removal of the major load, the depth reading is taken while the minor load is still on.

The hardness number may then be read directly from the scale. The indenter and the test load used determine the **hardness scale** that is used (**A, B, C, etc.**). For **soft materials** such as copper alloys, soft steel, and aluminum alloys a **1/16" diameter steel ball** is used with a **100-kilogram** load and the hardness is read on the **"B" scale**.

In testing **harder materials**, hard cast iron and many steel alloys, a **120 degrees diamond cone** is used with up to a 150 kilogram load and the hardness is read on the **"C" scale**.

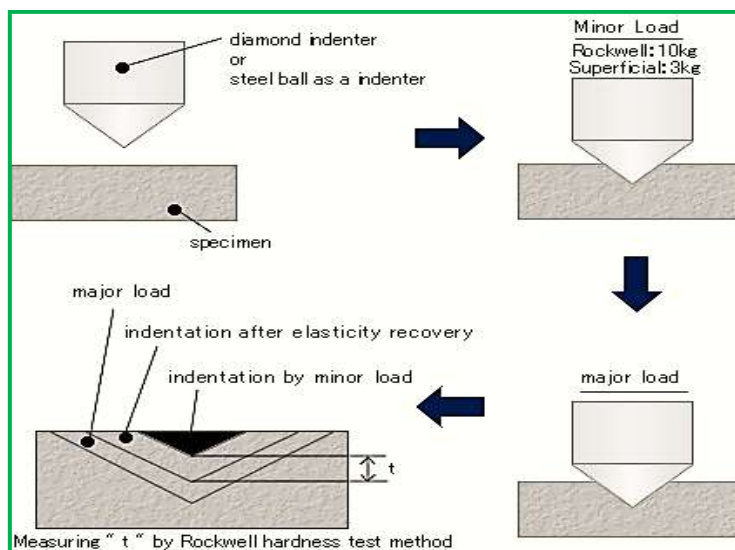

There are **several Rockwell scales other than the "B" & "C" scales**, (which are called the common scales). A properly reported Rockwell value will have the hardness number followed by "HR" (Hardness Rockwell) and the scale letter.

For example, **50 HRB** indicates that the material has a **hardness reading of 50 on the B scale**. The letters used in Rockwell scales are:

- A - Cemented carbides, thin steel and shallow case hardened steel;
- B - Copper alloys, soft steels, aluminum alloys, malleable iron, etc.;
- C - Steel, hard cast irons, pearlitic malleable iron, titanium, deep case hardened steel and other materials harder than B 100;
- D - Thin steel and medium case hardened steel and pearlitic malleable iron;
- E - Cast iron, aluminum and magnesium alloys, bearing metals;
- F - Annealed copper alloys, thin soft sheet metals;
- G - Phosphor bronze, beryllium copper, malleable irons;
- H - Aluminum, zinc, lead;
- K, L, M, P, R, S, V - Bearing metals and other very soft or thin materials, including plastics.

#### 9.4. Rockwell Superficial Hardness Test:

The Rockwell Superficial Hardness Tester is used to **test thin materials**, lightly carburized steel surfaces, or parts that might bend or crush under the conditions of the regular test. This tester uses the same indenters as the standard Rockwell tester but the loads are reduced.

The minor load is **3 kilograms**. The major load is either **15 or 45 kilograms** depending on the indenter used. Using the **1/16" diameter**, steel ball indenter, a **"T"** is added (meaning thin sheet testing) to this hardness designation. An example of a superficial Rockwell hardness is **23 HR15T**, which indicates the superficial hardness as **23**, with a **load of 15 kilograms**, using the steel ball.

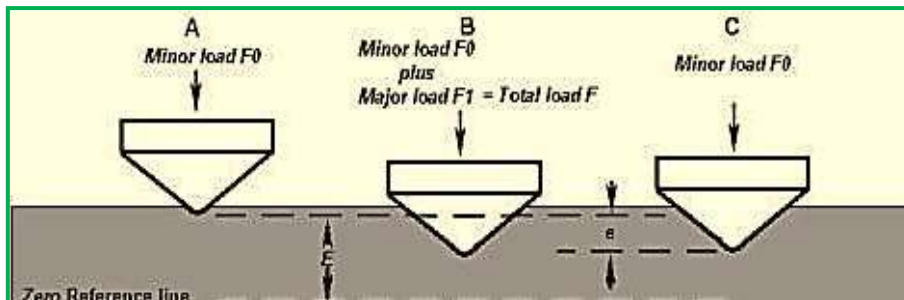

#### 9.5. Vickers and Knoop Micro hardness Tests:

The Vickers and Knoop Hardness Tests are a **modification of the Brinell test** used to measure the hardness of **thin film coatings** or the surface hardness of case-hardened parts.

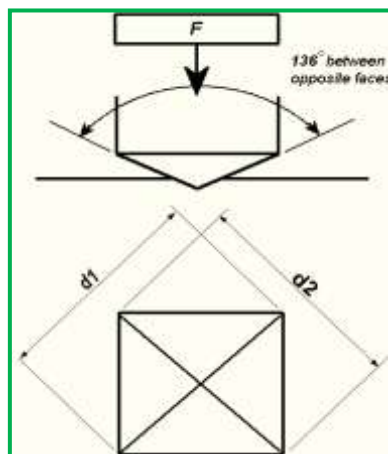

The Vickers test is performed with a **small diamond pyramid** pressed into the sample under loads that are much less than those used in the Brinell test. The difference between the **Vickers and the Knoop Tests** is simply the shape of the **diamond pyramid** indenter. The **Vickers** test uses a **square pyramidal indenter** and commonly used to characterize very **hard materials** but the hardness is measured over a very small region.

Consequently, the **Knoop** test uses a **rhombic-based** (diagonal ratio 7.114:1) **pyramidal indenter** which produces **longer but shallower** indentations. For the same load, Knoop indentations are about **2.8** times longer than Vickers indentations.

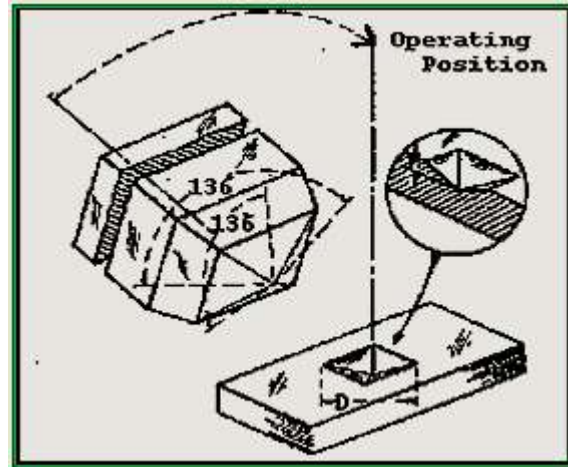
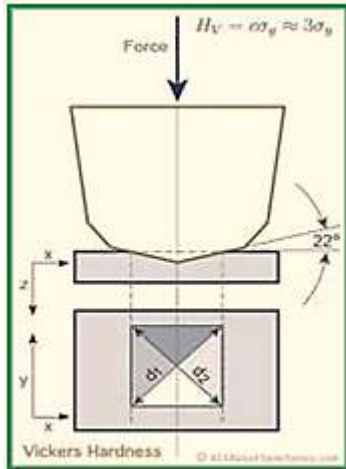

An applied load ranging from **10 g to 1,000 g** is used. This low amount of load creates a small indent that must be measured under a **microscope**. The measurements for hard coatings must be taken at very high magnification (i.e. 1000X), because the indents are so small. The **surface** usually needs to be **polished**. The diagonals of the impression are measured, and these values are used to obtain a hardness number (VHN), usually from a lookup table or chart.

The values are expressed like **2500 HK25** (or HV25) meaning **2500 Hardness Knoop at 25 gram force load**. The Knoop and Vickers hardness **values differ slightly**, but for hard coatings, the values are close enough to be within the measurement error and can be used interchangeably.

## 9.6. Scleroscope and Rebound Hardness Tests:

The Scleroscope test is a **very old test** that involves **dropping a diamond tipped hammer**, which falls **inside a glass tube** under the force of its **own weight** from a **fixed height**, onto the test specimen. The height of the rebound travel of the hammer is measured on a graduated scale.

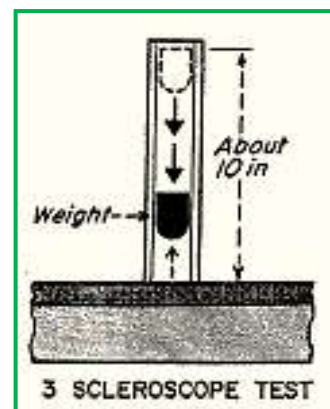
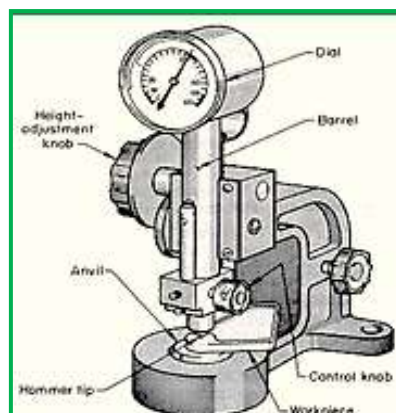

The scale of the rebound is **arbitrarily** chosen and consists on **Shore units**, divided into **100 parts**, which represent the average rebound from pure hardened high-carbon steel. The scale is continued higher than 100 to include metals having greater hardness.

The **Shore Scleroscope** measures hardness in terms of the elasticity of the material. The hardness number depends on the height of the hammer, the harder the material, the higher the rebound. The **Rebound Hardness Test Method** is a recent advancement that builds on the Scleroscope.

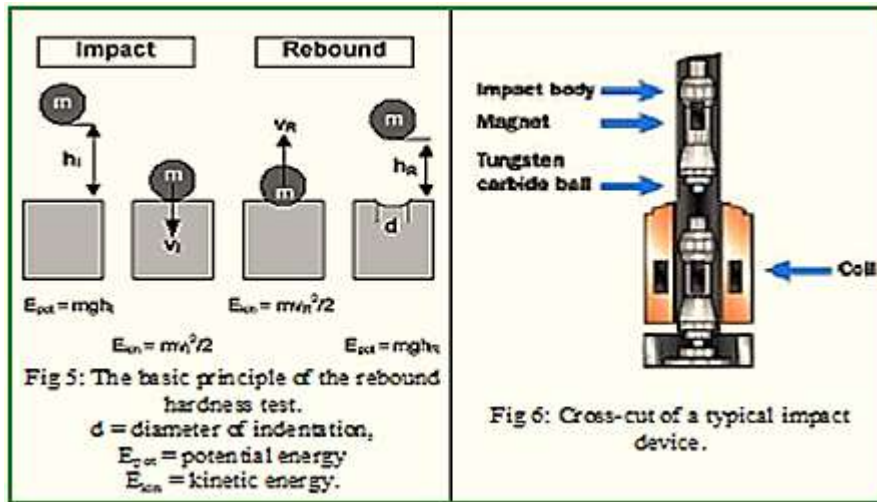

These instruments typically use a **spring to accelerate a spherical, tungsten carbide** tipped mass towards the surface of the test object. The kinetic energy and the impact produce an indentation (plastic deformation) on the surface which takes some of this energy from the impact body. The impact body will lose more energy and it rebound velocity will be less when a larger indentation is produced on softer material. The velocities of the impact body before and after impact are measured and the loss of velocity is **related to Brinell, Rockwell**, or other common hardness value.

### 9.7. Durometer Hardness Test:

A Durometer is an instrument that is commonly used for **measuring the indentation hardness of rubbers/elastomers and soft plastics** such as polyolefin, fluoropolymer, and vinyl.

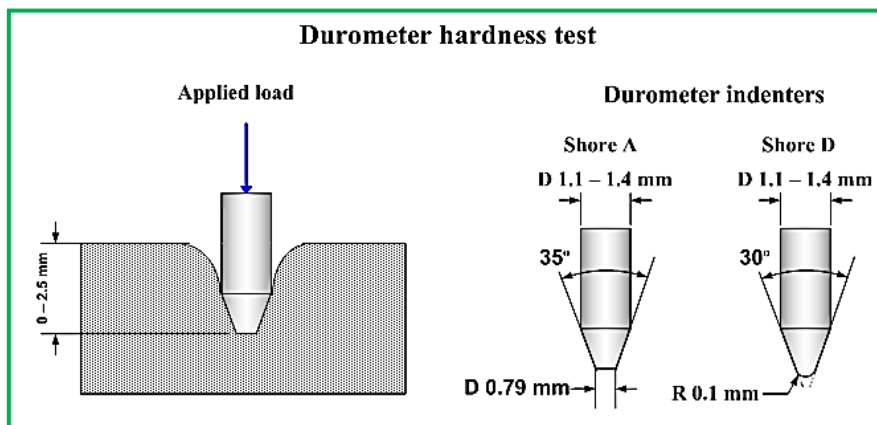

A Durometer simply uses a calibrated spring to **apply a specific pressure to an indenter** foot. The indenter foot can be either **cone or sphere shaped**. A device measures the depth of indentation. Durometers are available in a variety of models and the most popular testers are the **Model A** used for measuring **softer** materials and the **Model D** for **harder** materials.

## 9.8. Barcol Hardness Test:

The Barcol hardness test obtains a hardness value by measuring the **penetration of a sharp steel point** under a spring load. The specimen is placed under the **indenter of the Barcol hardness tester** and a uniform pressure is applied until the dial indication reaches a maximum.

The Barcol hardness test method is used to determine the hardness of **both reinforced and non-reinforced rigid plastics** and to determine the **degree of cure of resins** and plastics.

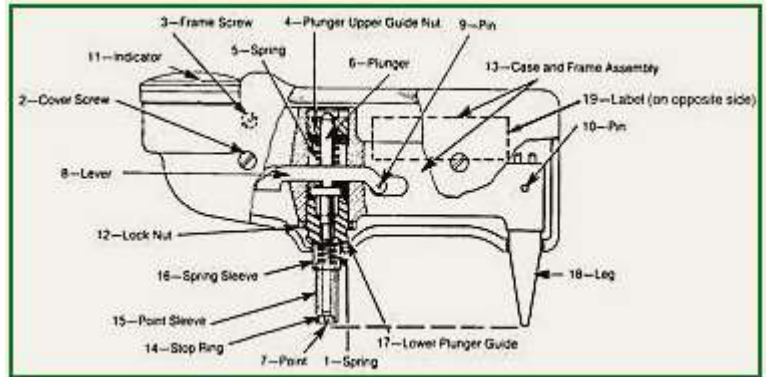

## 9.9. Creep and Stress Rupture Properties:

Creep is a time **deformation** of a material while under an applied load that is below its yield strength and often occurs at **elevated temperature**, but some materials creep at **room temperature**. Creep **terminates in rupture** if steps are not taken to bring to a stop. Creep data for general design use are usually obtained under conditions of constant uniaxial loading and constant temperature.

As indicated in the image, creep often takes place in **three stages**. In the **initial** stage, strain occurs at a relatively **rapid rate** but the rate gradually **decreases** until it becomes approximately constant **during the second stage**.

The constant creep rate is called the **minimum creep** rate or **steady-state creep rate** since it is the slowest creep rate during the test. In the **third stage**, the strain rate increases until failure occurs.

Creep in service is usually affected by changing conditions of loading and temperature and the number of possible stress-temperature-time combinations is infinite.

While most materials are subject to creep, the creep mechanism is often different between metals, plastics, rubber, concrete.

## III - WELDING SYMBOLS:

### 1. Elements of a Welding Symbol:

The first concepts the Welding Inspector must understand very well, are the welding symbols and how to interpret them on drawings. The reference line of the welding symbol, as shown below, is used to designate the type of weld to be made, its location, dimensions, extent, contour, and other supplementary information.

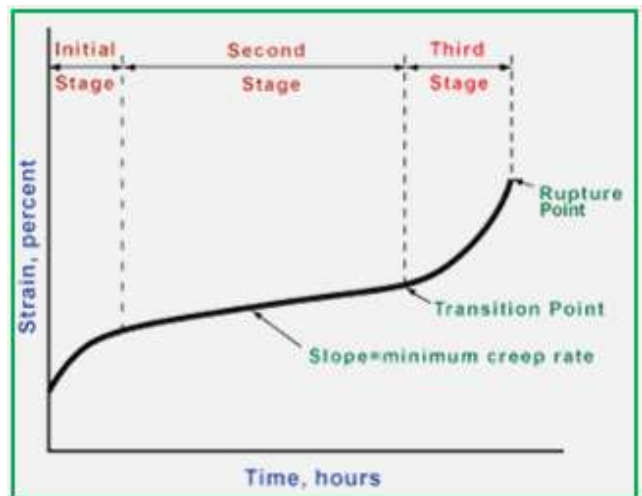



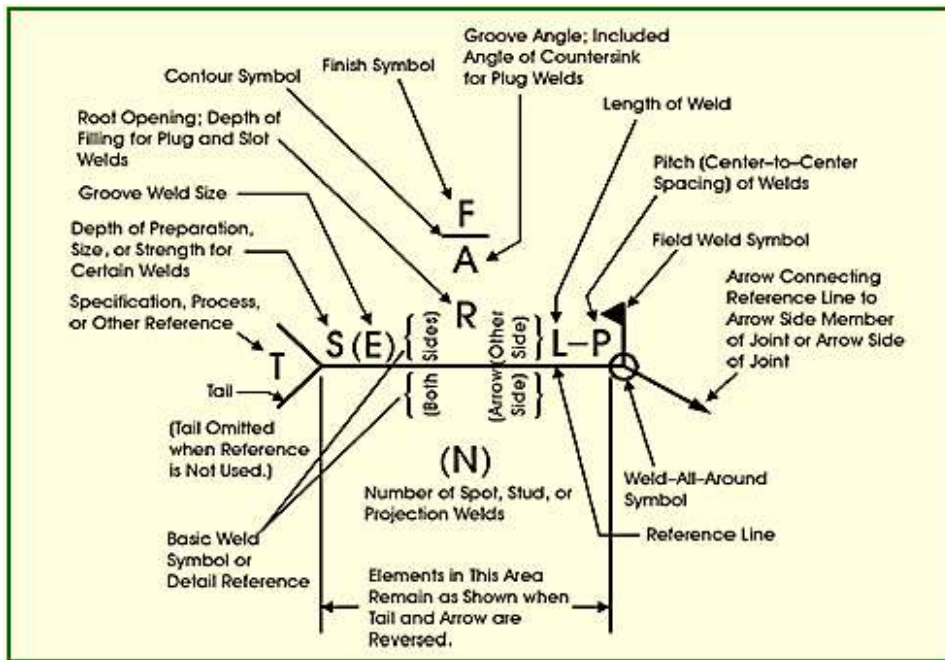

## 2. Supplementary Symbols:

A distinction is made between the terms "weld symbol" and "welding symbol". The **"weld symbol"** below indicates the desired type of weld. The **"welding symbol"** consists of the following eight elements, or any of these elements are necessary:

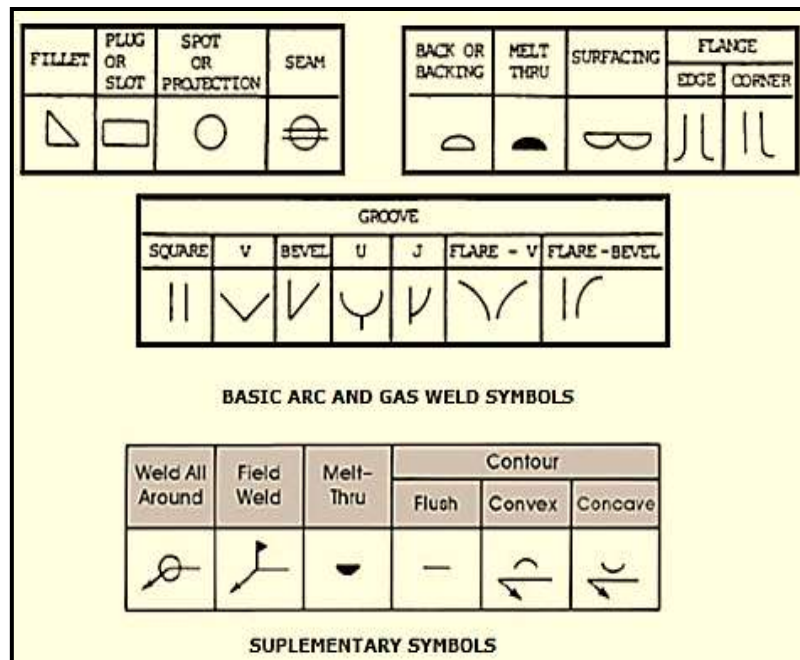

**Supplementary information:** Reference line, arrow, basic weld symbols, dimensions and other data, supplementary symbols, finish symbols, tail, and specification, process, or other reference. The circle used as the weld-all-around symbol means that welding is to be all around the joint. The small flag, or field weld symbol, means the weld is to be made in the field. The solid black semicircle, or melt-thru symbol, indicates the weld is made by melting through the top piece into a lower piece.

The tail of the symbol is used for designating the welding and cutting processes as well as the welding specifications, procedures, or the supplementary information in making the weld.

If a welder knows the size and type of weld, he has only part of the information necessary for making the weld. The process, identification of filler metal that is to be used, whether or not peening or root chipping is required, and other pertinent data must be related to the welder.

### 3. Definitions of Weld Symbols:

a. When the use of a definite process is required the process may be indicated by one or more of the letter designations, as shown.

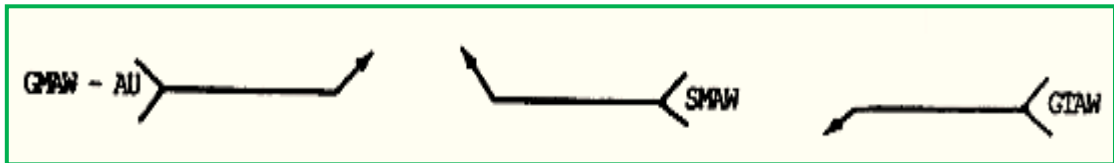

**Obs.:** Letter designations have not been assigned to arc spot, resistance spot, arc seam, resistance seam, and projection welding since the weld symbols used are adequate.

b. When no specification, process, or other symbol, the tail may be omitted. The reference is used as an indication of a common welding process.

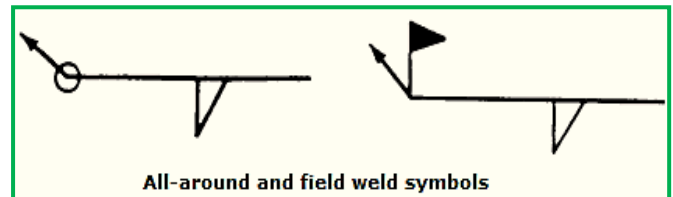
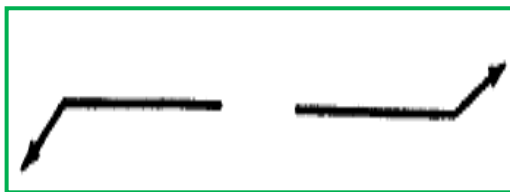

c. Other common weld symbols, as above and below, illustrate the weld-all-around and field weld symbol, and resistance spot and resistance seam welds.

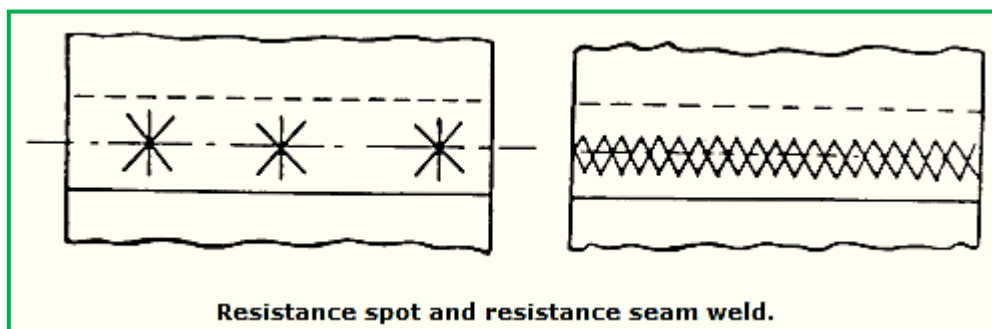

### 3.1. Location Significance of Arrow:

a. Fillet, Groove, Flange, Flash, and Upset welding symbols. For these symbols, the arrow connects the welding symbol reference line to one side of the joint and this side shall be considered the arrow side of the joint. The side opposite the arrow side is considered the other side of the joint.

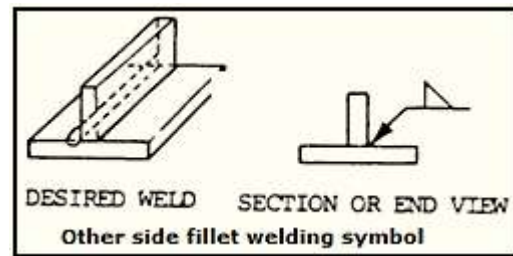
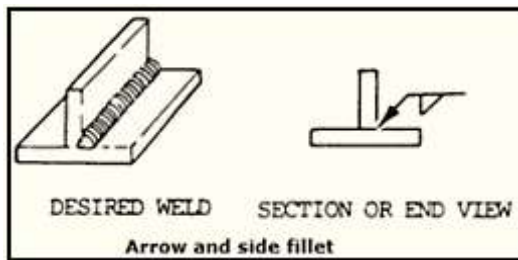

**b.** Plug, Slot, Arc Spot, Arc Seam, Resistance Spot, Resistance Seam and Projection Symbols. For these symbols, the arrow connects the welding symbol reference line to the outer surface of one part of the joint at the center line of the desired weld. The part to which the arrow points is considered the arrow side. The other part of the joint shall be considered the other side.

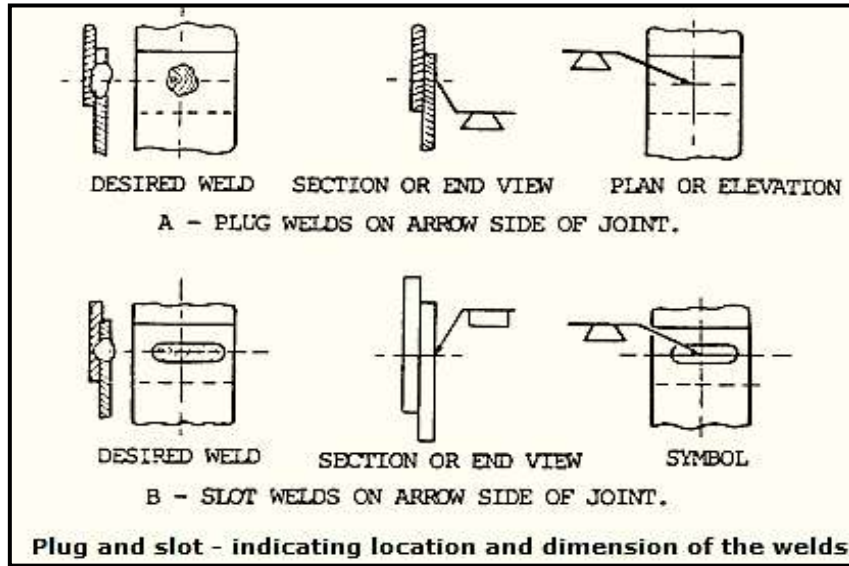

**c.** Near Side. When a joint is depicted by a single line on the drawing and the arrow of a welding symbol is directed to this line, the arrow side of the joint is considered as the near side of the joint, in accordance with the usual conventions of drafting.

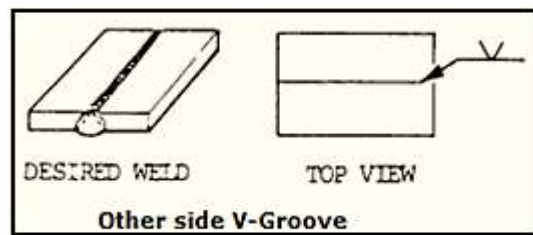
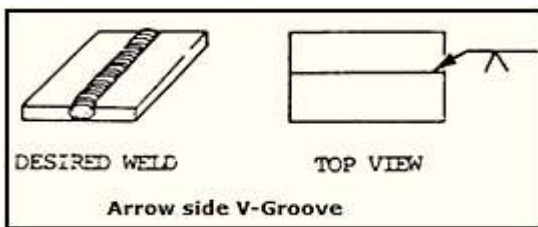

### 3.2. Location of the Weld with Respect to Joint:

**a.** Arrow Side. Welds on the arrow side of the joint are shown by placing the weld symbol on the side of the reference line toward the reader.

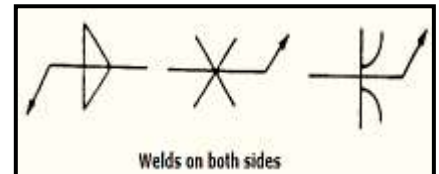
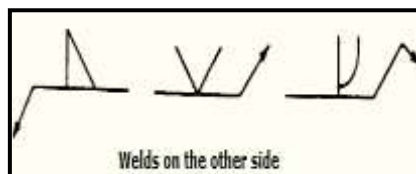
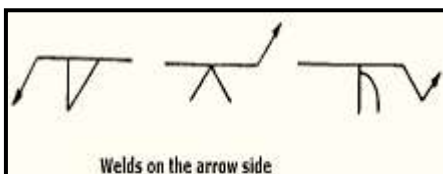

**b. No Side Significance.** Resistance spot, resistance seam, flash, weld symbols have no arrow side or other side significance in themselves, although supplementary symbols used in conjunction with these symbols may have such significance.

See the example below, the flush contour symbol is used in conjunction with the spot and seam symbols to show that the exposed surface of one member of the joint is to be flush. Resistance spot, resistance seam, flash, and upset weld symbols shall be centered on the reference line.

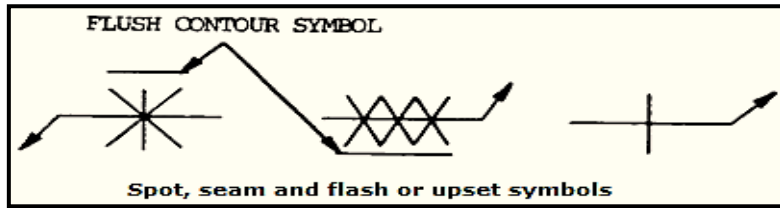

**c. General Notes.** General notes similar to the following may be placed on a drawing to provide detailed information to predominant welds. This information needs not be repeated on the symbols:

- (1) "Unless otherwise indicated, all fillet welds are 5/16 in. size."
- (2) "Unless otherwise indicated, root openings for all groove welds are 3/16 in. size"

**3.3. Use of Inch, Degree and Pound Marks:**

**a.** Inch marks are used for indicating the diameter of arc spot, resistance spot, and circular projection welds, and the width of arc seam and resistance seam welds when such welds are specified by decimal dimensions. In general, inch, degree, and pound marks may be used on welding symbols, as desired.

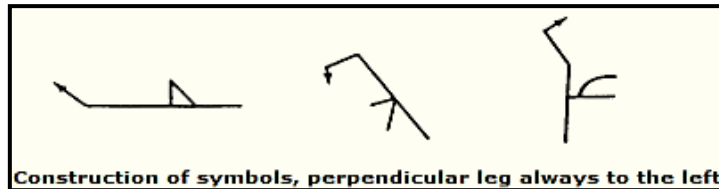

**b.** In a bevel or J-groove weld symbol, the arrow shall point with a definite break toward the member which is to be chamfered. In cases where the member to be chamfered is obvious, the break in the arrow may be omitted.

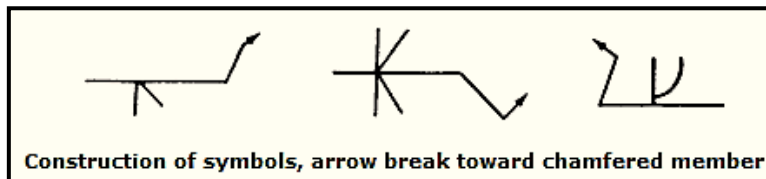

**c.** Information on welding symbols shall be placed to read from left to right along the reference line in accordance with the usual conventions of drafting.

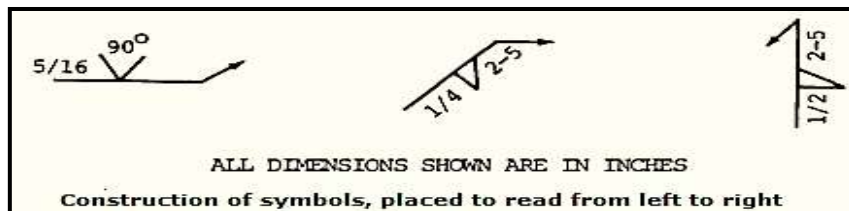

d. For joints having more than one weld, a symbol shall be shown for each weld.

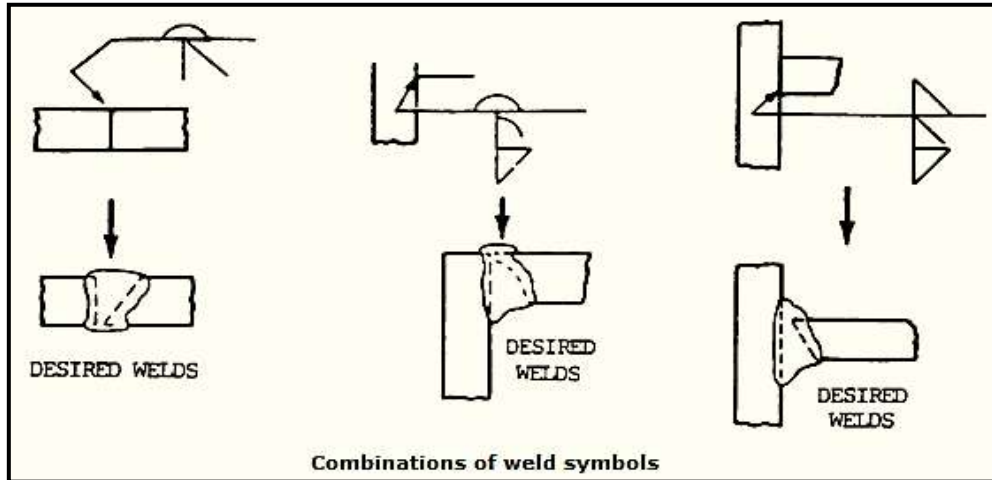

e. The letters CP in the tail of the arrow indicate a complete penetration weld regardless of the type of weld or joint preparation.

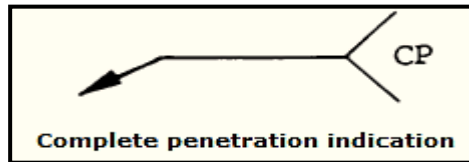

f. When the basic weld symbols are inadequate to indicate the desired weld, the weld shall be shown by a cross section, detail, or other data with a reference on the welding symbol according to location specifications.

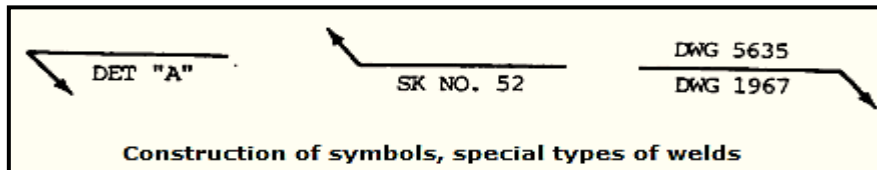

g. Two or more reference lines may be used to indicate a sequence of operations. The first operation must be shown on the reference line nearest the arrow. The field weld symbol may also be used in this manner.

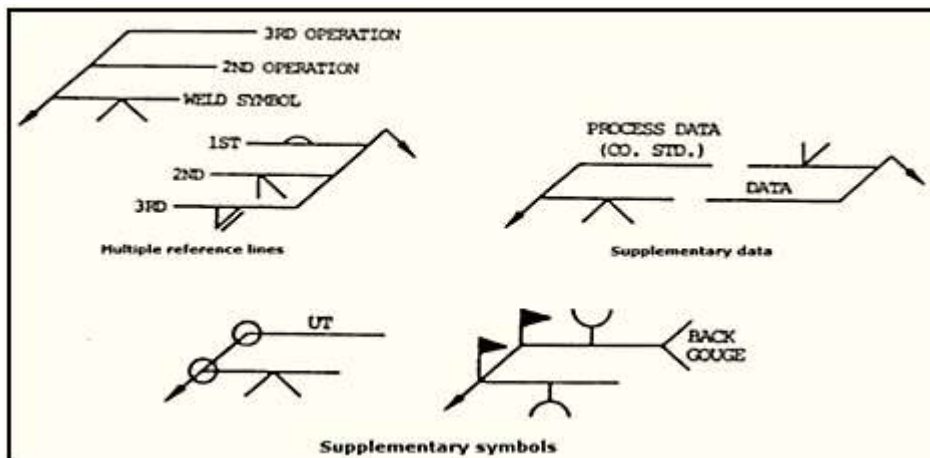

### 3.4. Groove Welding Symbols:

a. Dimensions of groove welds must be shown on the same side of the reference line as the weld symbol.

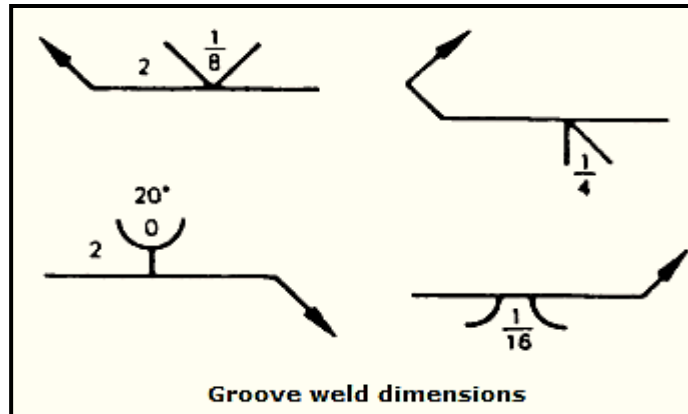

b. When no general note governing the dimensions of double groove welds appears, dimensions shall be shown as follows:

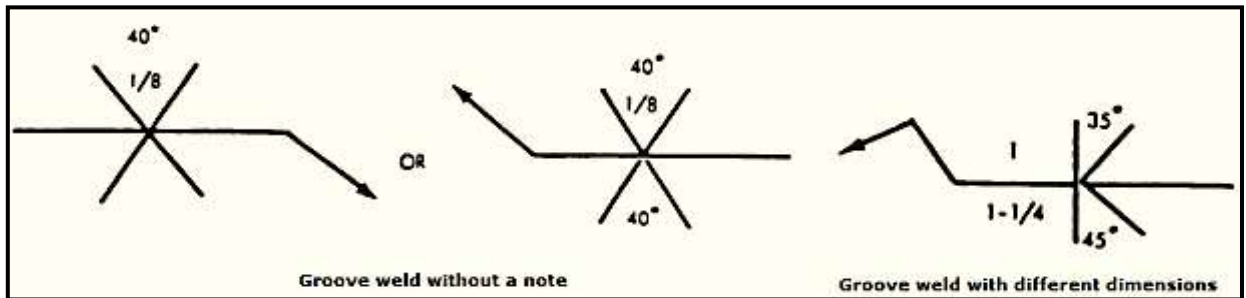

c. Size of Groove Welds. The size of single groove and symmetrical double groove welds which extend completely through the member or members being joined need not be shown on the welding symbol.

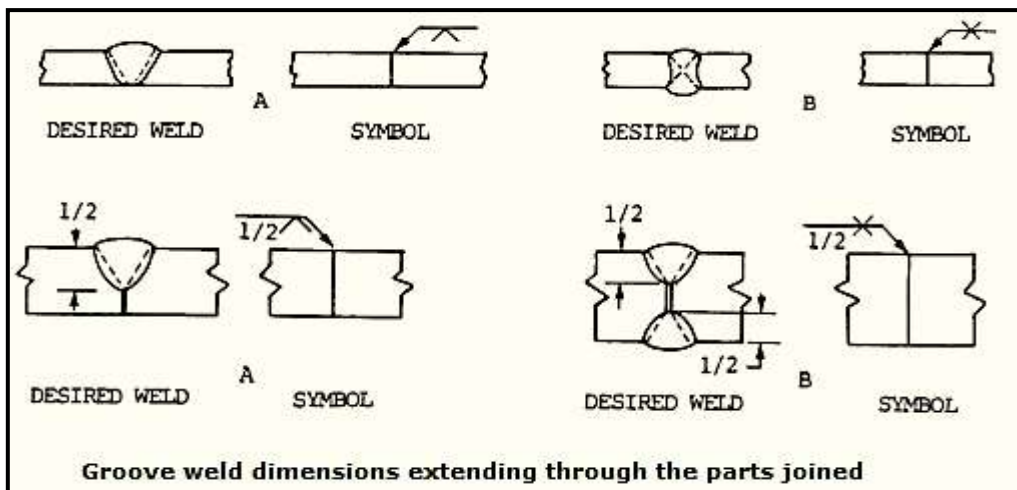

d. The groove welds, size of groove welds with specified root penetration, except square must be indicated by showing the depth of chamfering and the root penetration separated by a plus mark and placed to the left of the weld symbol. The depth of chamfering and the root penetration must read in that order from left to right along the reference line.

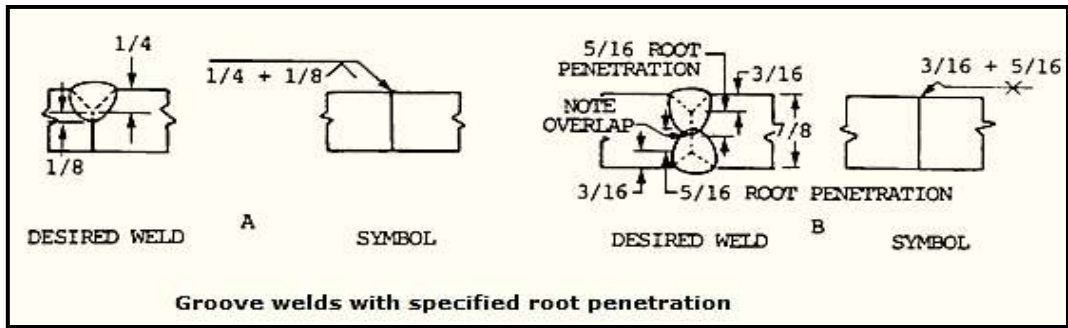

e. The size of flare groove welds is considered to extend only to the tangent points as indicated by dimension lines.

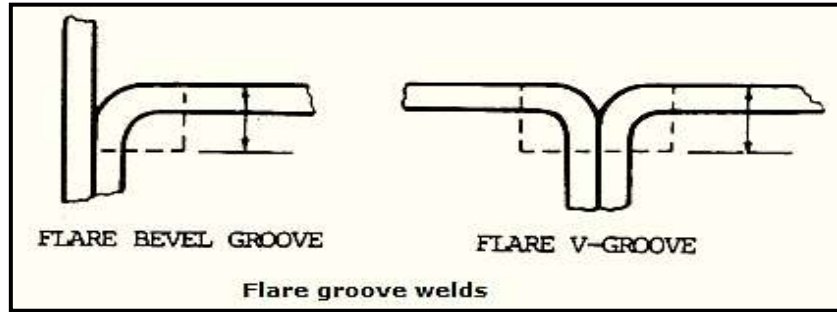

f. Root opening, groove angle, groove radii, and root faces of the U and J groove welds are the user's standard unless otherwise indicated.

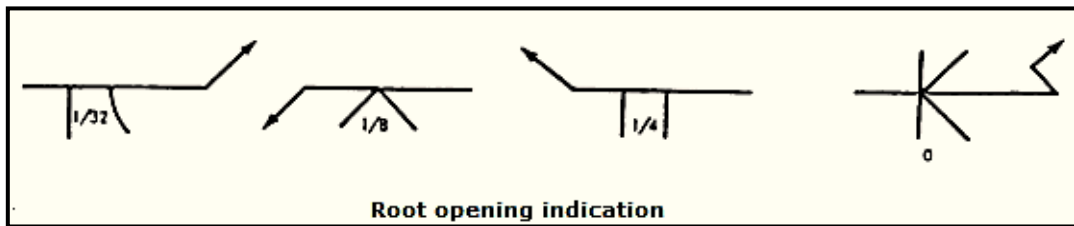

g. Back and Backing Welds. Bead-type back and backing welds of single-groove welds shall be shown by means of the back or backing weld symbol.

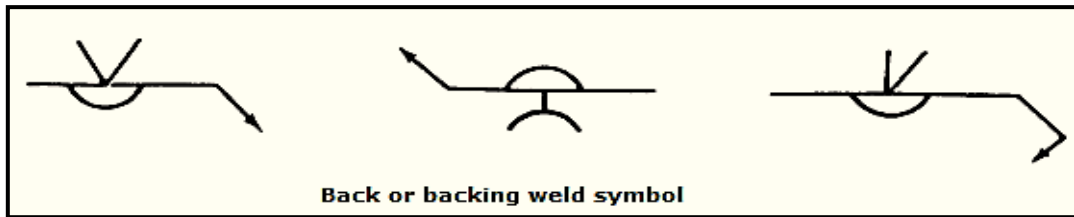

h. Surface Contour of Groove Welds. The contour symbols for groove welds are indicated in the same manner as that for fillet welds.

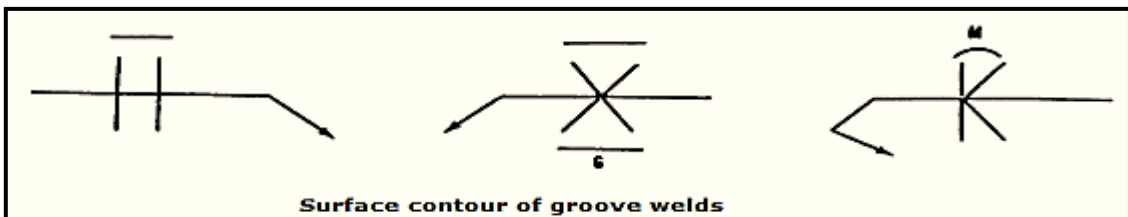

i. Groove welds that are to be welded approximately flush without recourse to any method of finishing shall be shown by adding the flush contour symbol to the weld symbol, in accordance with the location specifications given in paragraph.

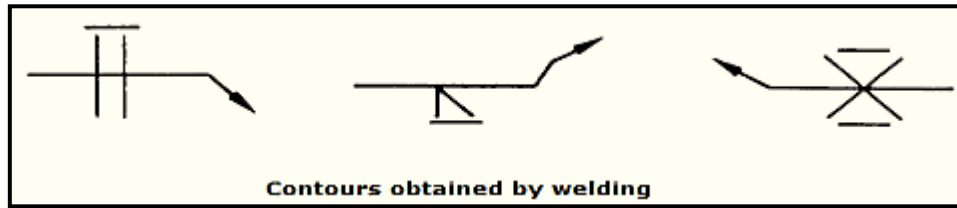

j. Groove welds that are to be made flush by mechanical means shall be shown by adding the flush contour symbol and the user's standard finish symbol to the weld symbol, in accordance with the location specifications given in paragraph.

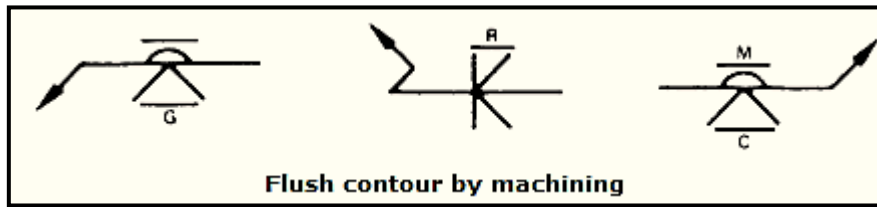

k. Groove welds that are to be mechanically finished to a convex contour shall be shown by adding both the convex contour symbol and the user's standard finish symbol to the weld symbol.

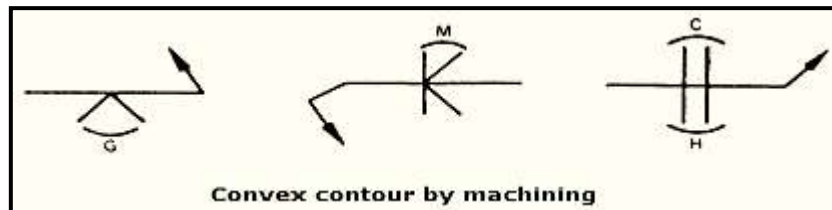

l. Surface Contour of Back or Backing Welds. The contour symbols for back or backing welds are indicated in the same manner as that for fillet welds.

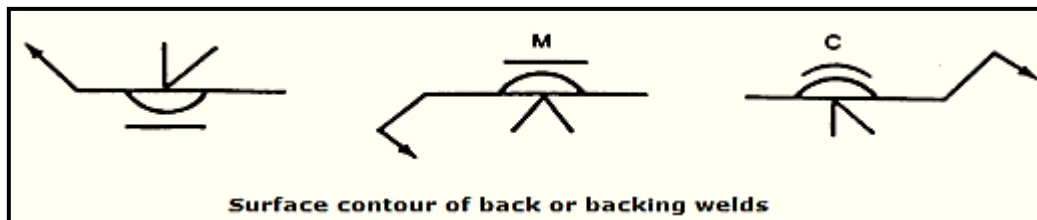

### 3.5. Melt-thru Welds:

a. The melt-thru symbol shall be used where at least 100 percent joint penetration of the weld through the material is required in welds made from one side only.

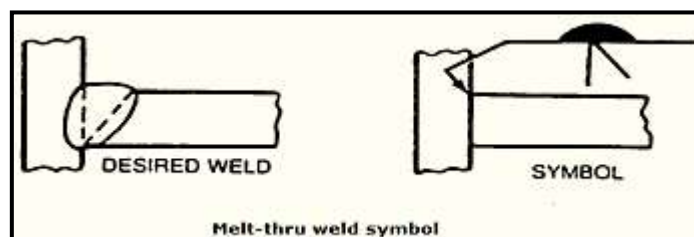



**b. Surface Contour of Melt-thru Welds.** The contour symbols for melt-thru welds are indicated in the same manner as that for fillet welds.

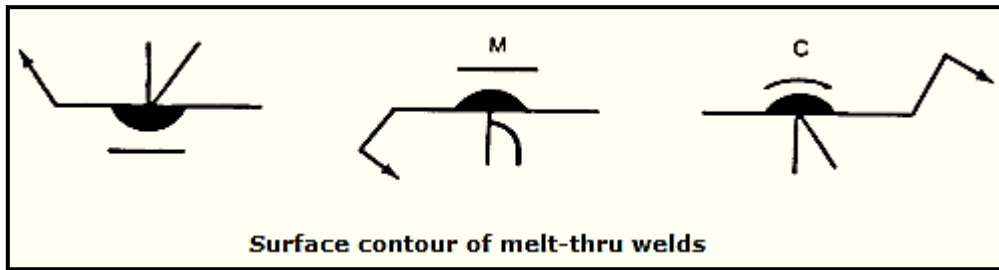

### 3.6. Surfacing Welds:

The surfacing weld symbol shall be used to indicate surfaces built up by, whether built up by single-or multiple-pass surfacing welds. The size (height) of a surface built up by welding shall be indicated by showing the minimum height of the weld deposit to the left of the weld symbol.

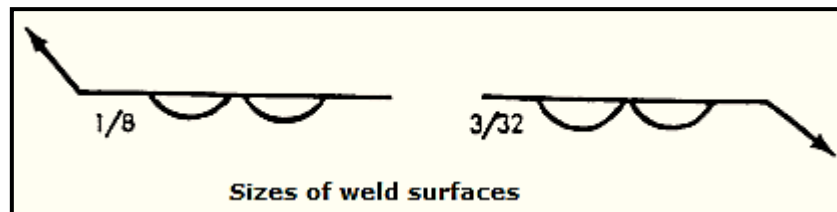

### 3.7. Flange Welds:

Edge flange welds shall be shown by the edge flange weld symbol. Corner flange welds shall be shown by the corner flange weld symbol. In cases where the corner flange joint is not detailed, a break in the arrow is required to show which member is flanged.

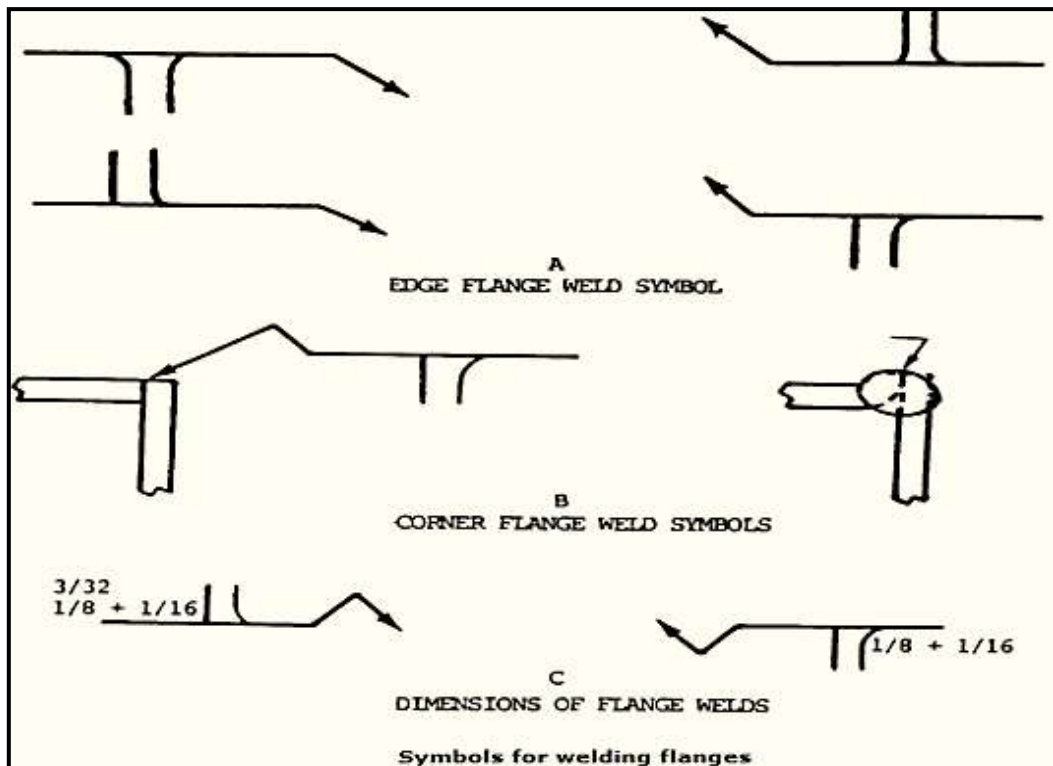

### 3.8. Groove Welds:

In the following figures, the perspective drawings of welded joints are shown at the left, looking at each joint from the arrow side. The illustrations cover only a small number of all possible symbols. The symbols shown here are those of the most common manufacturing application.

The welding symbols for **square-grooved butt joints**, under three conditions, are shown below.

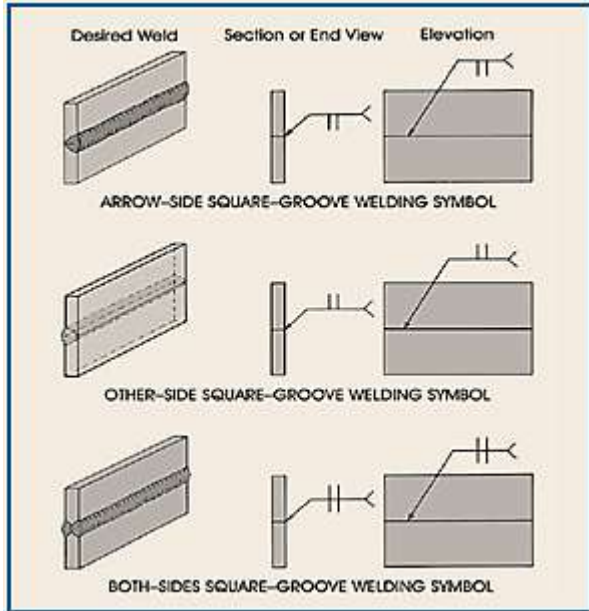

The **V-groove welding symbol** indicates the arrow-side, other-side, and both-sides welds.

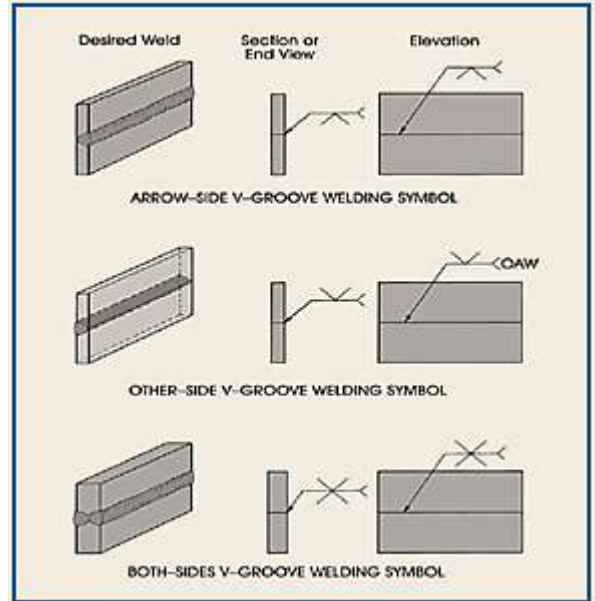

Note that the weld symbol may be placed above, **below**, or **on both sides** of the reference line.

The other-side weld, oxyacetylene welding (OAW) is indicated as the process to be used.

The U-groove symbols, means that the weld is to be made on both sides.

The symbol above the line, means the backing weld is to be on the other side of the joint.

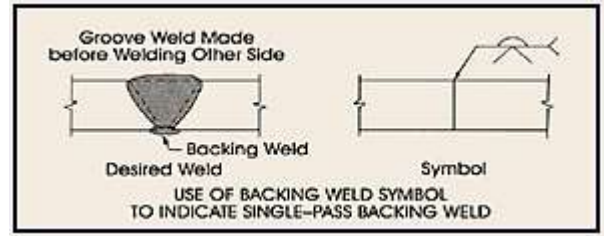
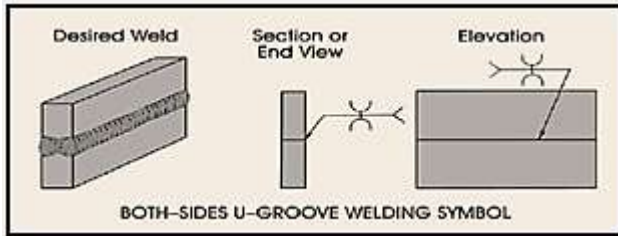

### 3.9. Fillet Welds Dimensions:

a. Dimensions of fillet welds must be shown on the same side of the reference line as the weld symbol. When fillet welds are indicated on both sides of a joint and no general note governing the dimensions of the welds appears on the drawing.

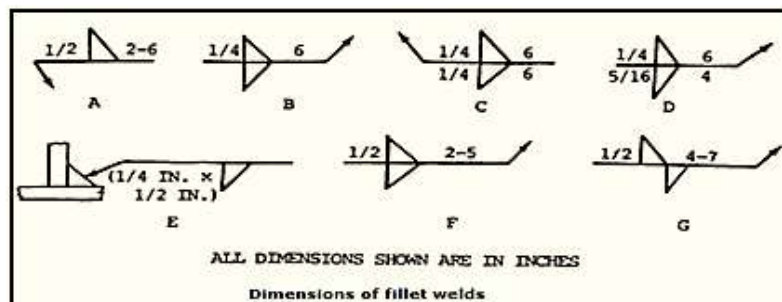

**OBS.:** If the dimensions of one or both welds differ from the dimensions given in the general note, both welds must be dimensioned. The size the fillet weld with unequal legs must be shown in parentheses to left of the weld symbol.

**b.** The length of a fillet weld, when indicated on the welding symbol, must be shown to the right of the weld symbol. When fillet welding extends for the full distance between abrupt changes in the direction of the welding, no length dimension need be shown on the welding symbol.

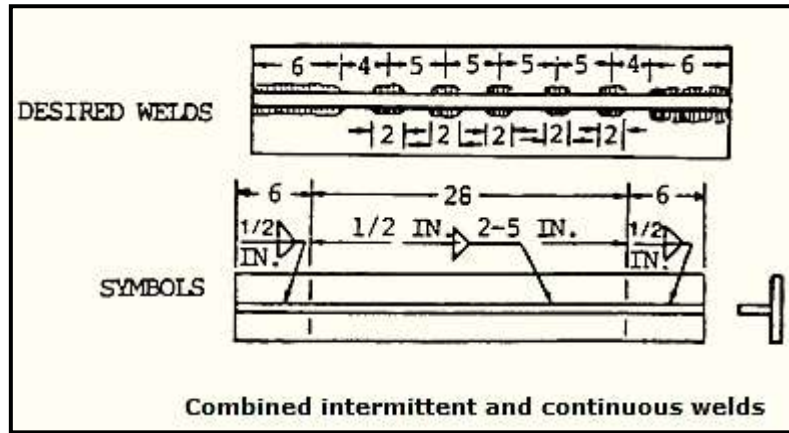

**c.** Fillet welding extending beyond abrupt changes in the direction of the welding must be indicated by additional arrows pointing to each section of the joint to be welded except when the weld-all-around symbol is used.

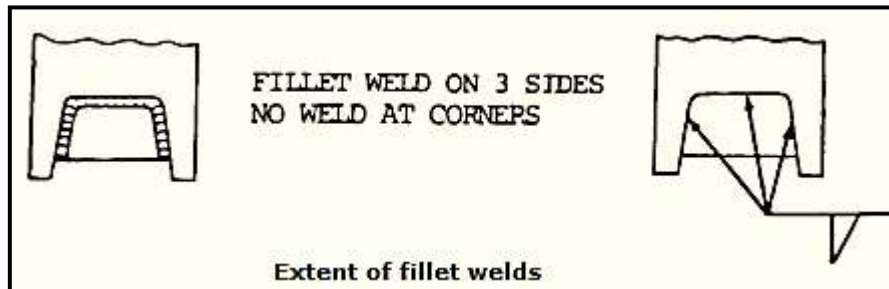

**d.** Unless otherwise specified, chain and staggered intermittent fillet welds on both sides shall be symmetrically spaced, or, when intermittent fillet welding is used by itself, the symbol indicates that increments are located at the ends of the dimensioned length.

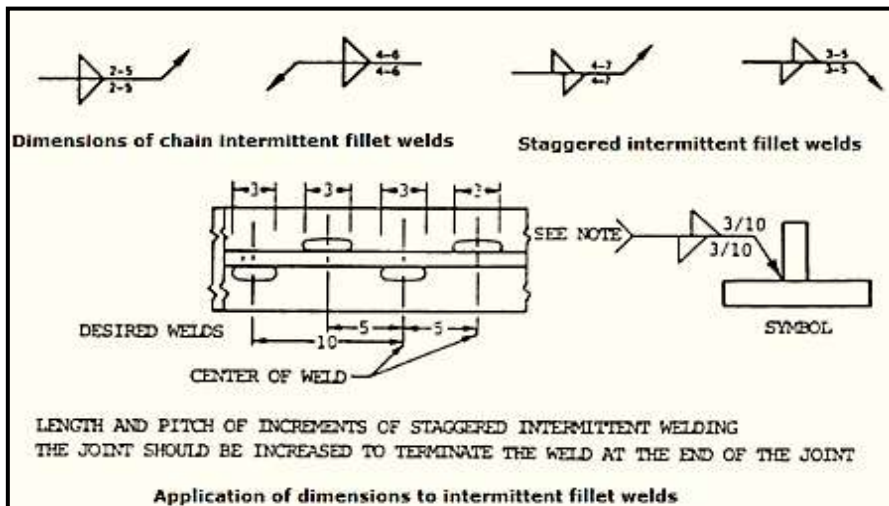

e. Surface contour. Fillet welds that are to be welded approximately flat, convex, or concave faced without recourse to any method of finishing must be shown by adding the flush, convex, or concave contour symbol to the weld symbol.

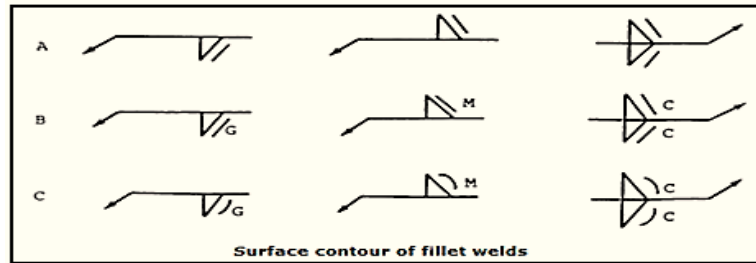

**OBS.:** Finish symbols used here indicate the method of finishing ("c" = chipping, "G" = grinding, "H" = hammering, "M" = machining), not the degree of finish.

### 3.10. Fillet Welds Types:

a. **Single-fillet-welded T-joints.** Indicated from both the arrow side and the other side. The symbol for a **double fillet-welded T-joint** is also illustrated. Note that the assembly of two T-joints welded pieces involves **four fillet welds** represented by **two double-fillet-weld** symbols.

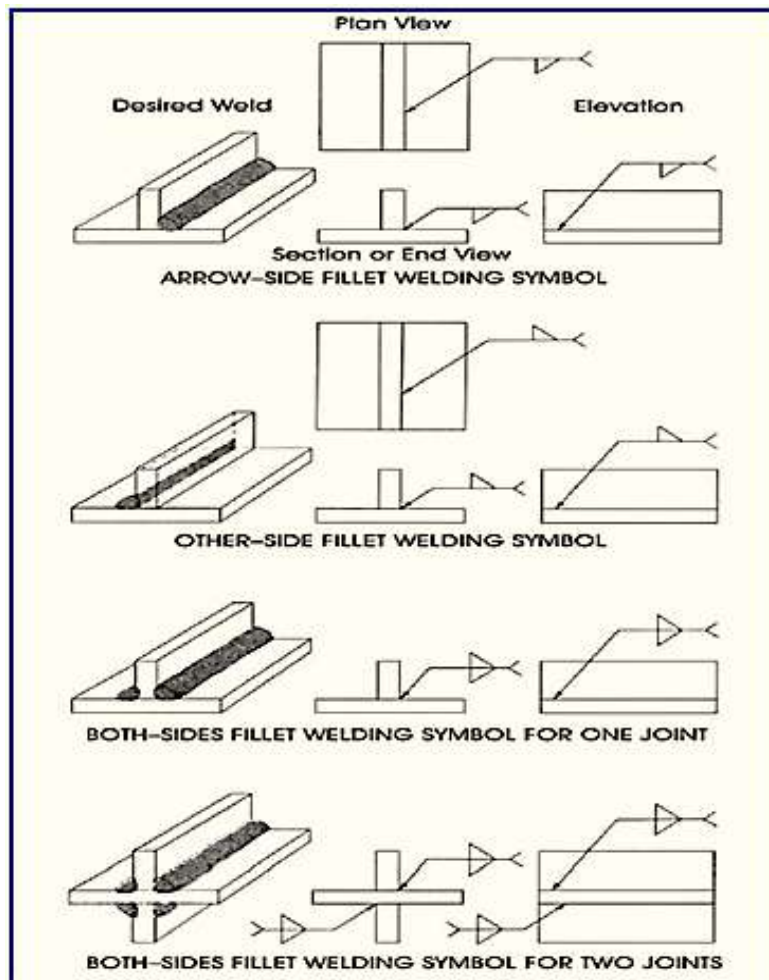

b. **Fillet Combined Welding.** The most common fillet weld in conjunction with a bevel- or J-groove weld. The fillet weld can be added if the bevel- or J-groove weld is on a corner or a T-joint.

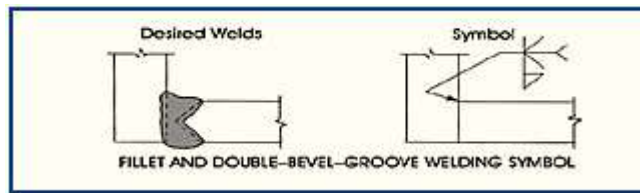

**c. Fillet Weld Root Penetration.** Weld penetration beyond the depth of the groove is indicated below. The first dimension gives the depth of penetration into the groove; the second dimension gives the additional penetration into the joint root.

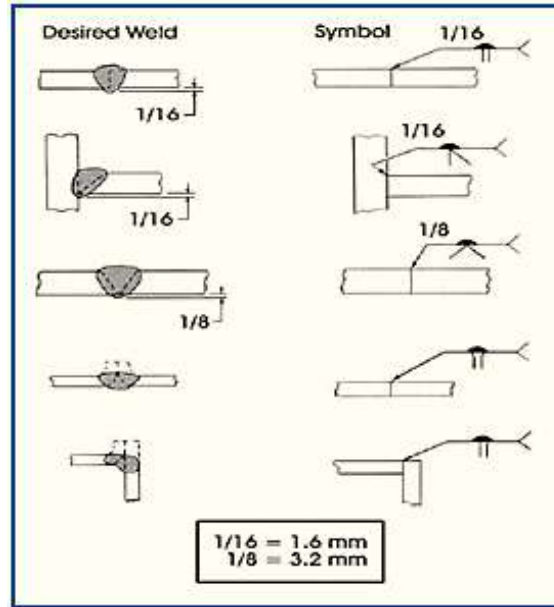

**d. Dimensioning Fillet Weld Symbols.** Take pattern on the desired sizes of fillet welds, because welders usually can't determine the dimensions of the parts to be welded. The drawings of the welded joints are shown on the left and the dimensioned symbol for each joint is shown on the right.

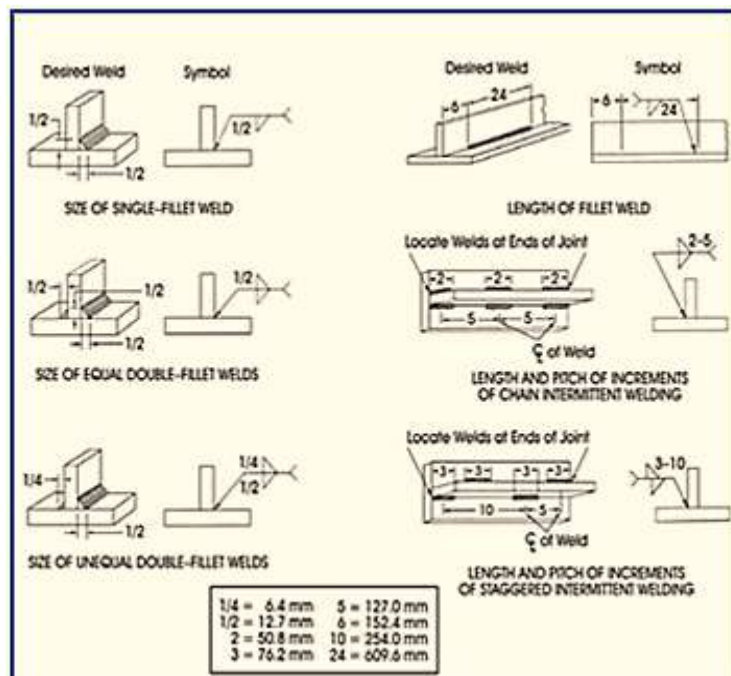

### 3.11. Flare V-groove Welding Symbols:

The flare-V-groove weld is created when two flanged relatively thin sheets or plates are joined. This joint shape is different from the conventional V and so needs a different symbol.

One piece of the joint is rounded while the other member is flat.

The flanged, or flared edge is at a right angle to the sheet or plate.

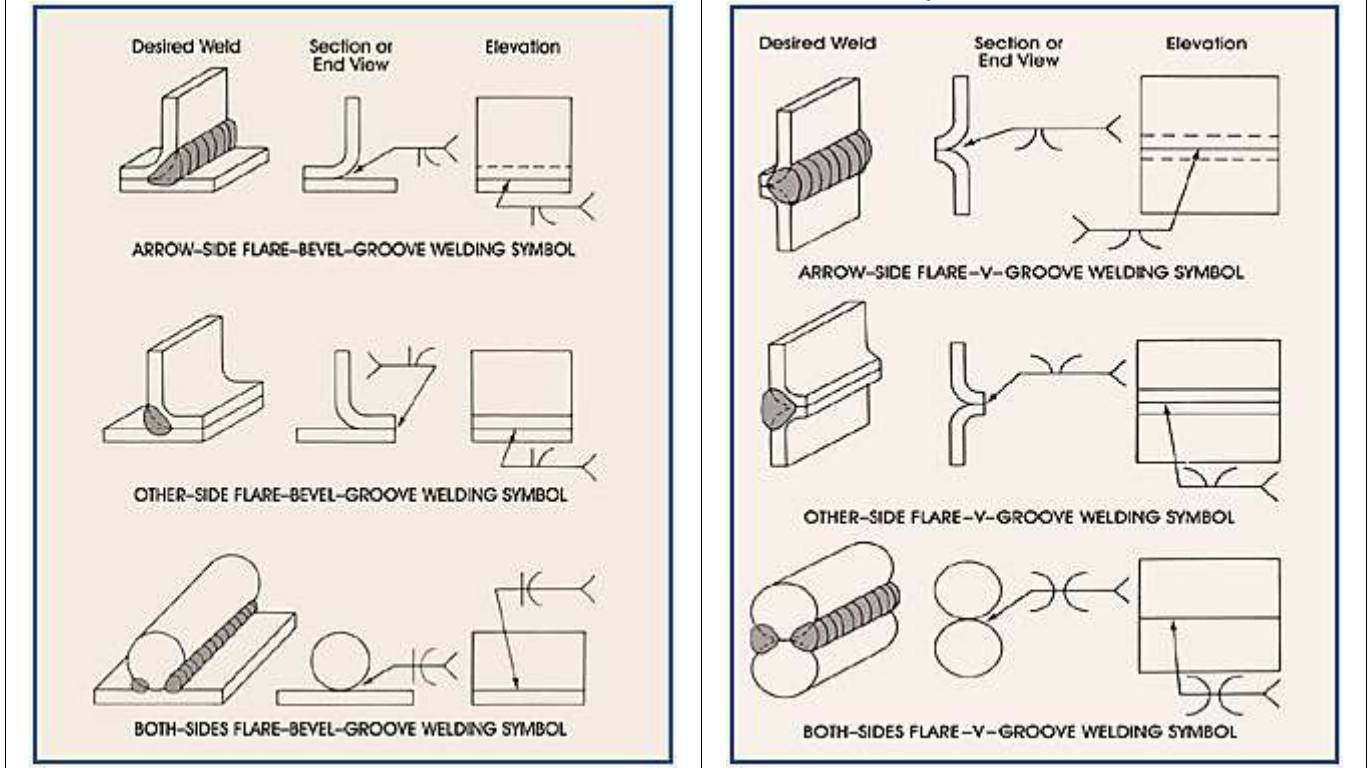

### 3.12. Contour Symbols for Welding:

Standard letters are used to indicate finishing operations as "**C**" for *chipping*, "**G**" for *grinding*, "**M**" for *machining*, "**R**" for *rolling*, and "**H**" for *hammering*.

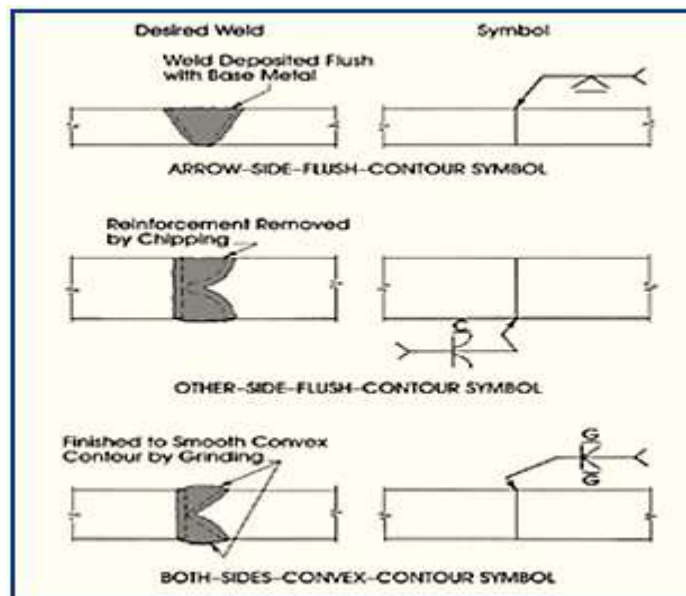

### 3.13. Indicating Sizes on Symbols:

The mechanical welding designers can specify to the welders **the sizes of root openings, specific groove angles, root penetrations, the lengths of fillet welds, and the spacing** of weld beads.

The root opening, or the minimum spacing between members of a joint, is indicated.

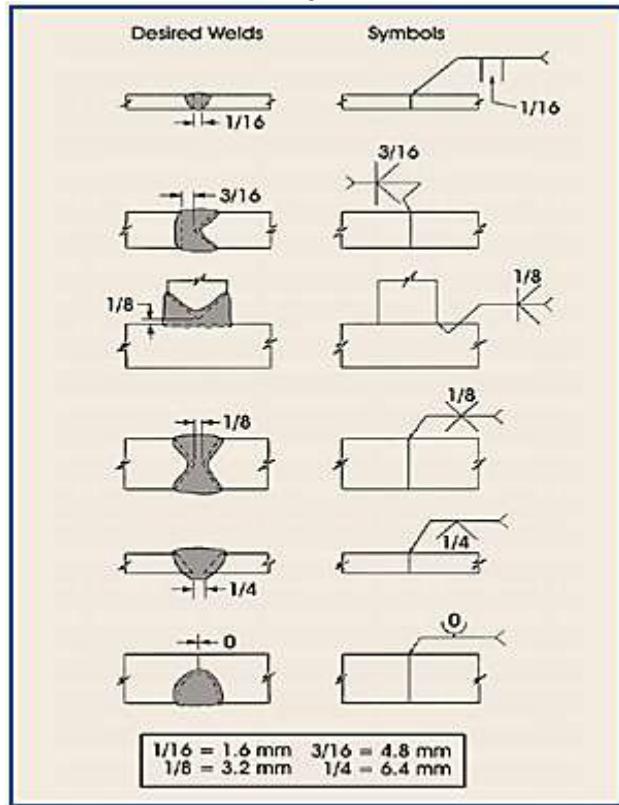

The angle or angles required for the preparation of joints are placed within the basic weld symbol.

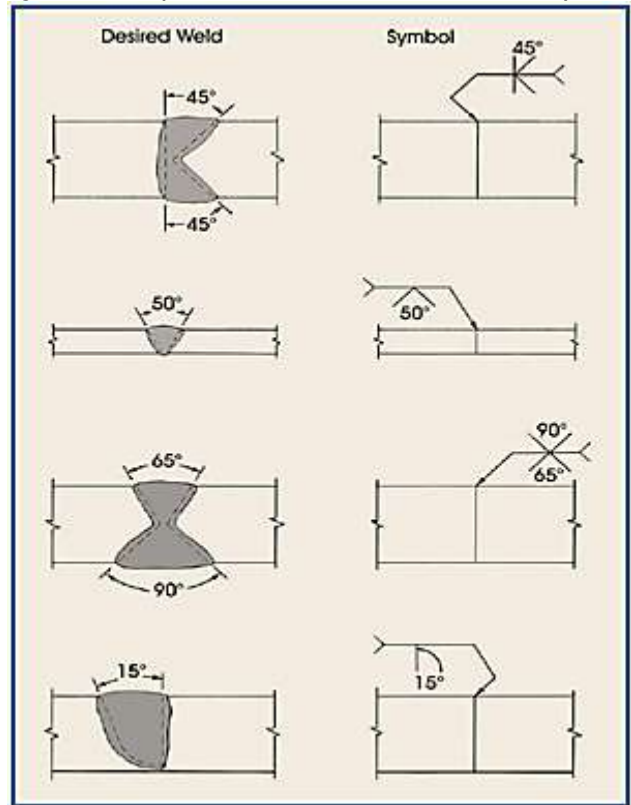

### 3.14. Plug and Slot Welding Symbols:

**a. Plug Weld Dimensions.** Dimensions of plug welds must be shown on the same side of the reference line as the weld symbol. The size of a weld must be shown to the left of the weld symbol.

Angle of countersink, when not a standard, must be shown either above or below the weld symbol. The pitch (center-to-center spacing) of plug welds shall be shown to the right of the weld symbol.

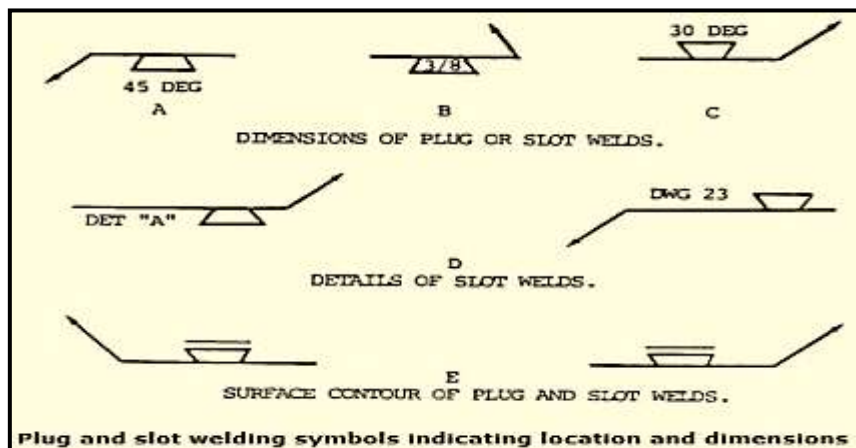

**b. Surface Contour of Plug Welds and Slot Welds.** Plug welds that are to be welded approximately flush without recourse to any method of finishing must be shown by adding the finish contour symbol to the weld symbol.

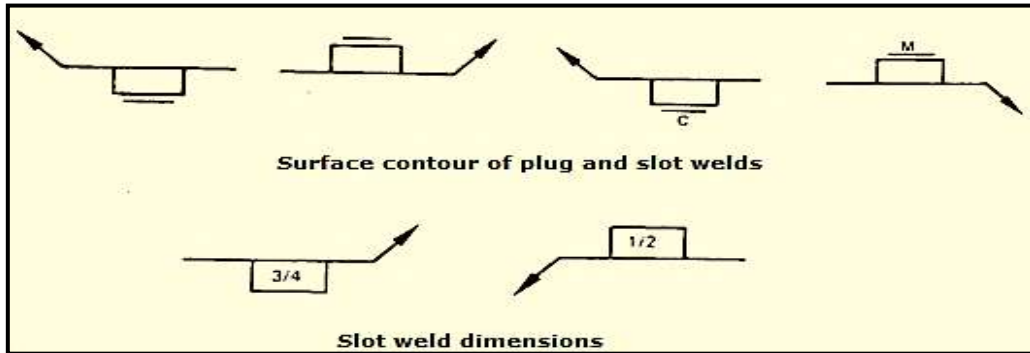

**3.15. Arc Spot and Arc Seam Welds:**

**a.** The size of arc spot welds must be designated as the diameter of the weld. Arc seam weld size shall be designated as the width of the weld. Dimensions will be expressed in fractions or in decimals in hundredths of an inch and shall be shown, with or without inch marks, to the left of the weld symbol.

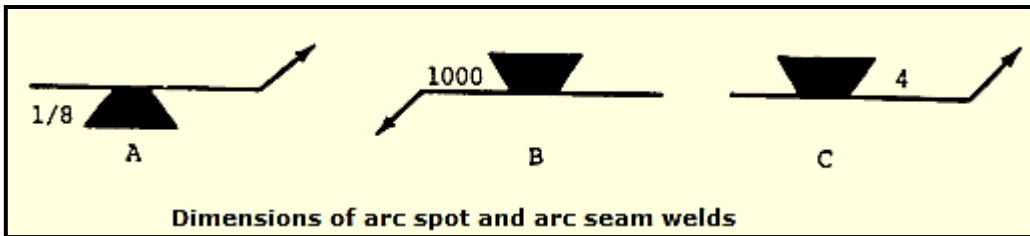

**b.** Spacing of Arc Spot and Arc Seam Welds. The pitch (center-to-center spacing) of arc spot welds and, when indicated, the length of arc seam welds, must be shown to the right of the weld symbol.

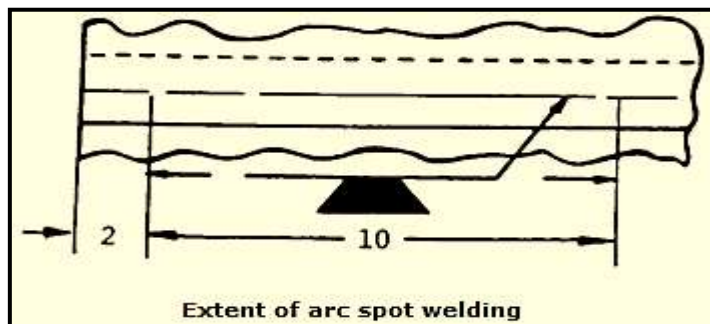

**c.** When a definite number of arc spot welds are desired in a certain joint, the number must be shown in parentheses either above or below the weld symbol.

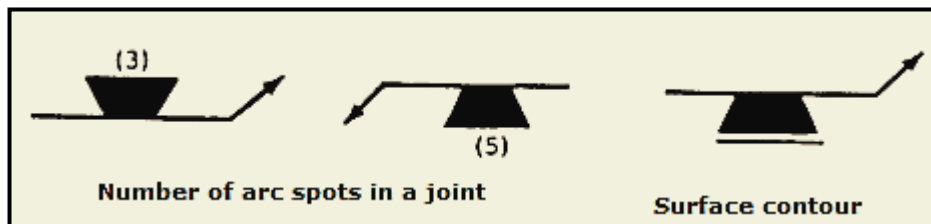



### 3.16. Projection Welds:

a. When using projection welding, the spot weld symbol must be used with the projection welding process reference in the tail of the welding symbol. The spot weld symbol must be centered on the reference line.

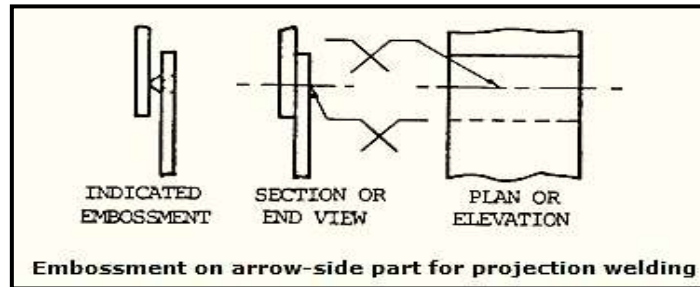

b. The size of circular projection welds shall be designated as the diameter of the weld expressed in fractions or in decimals in hundredths of an inch and shall be shown, with or without inch marks, to the left of the weld symbol.

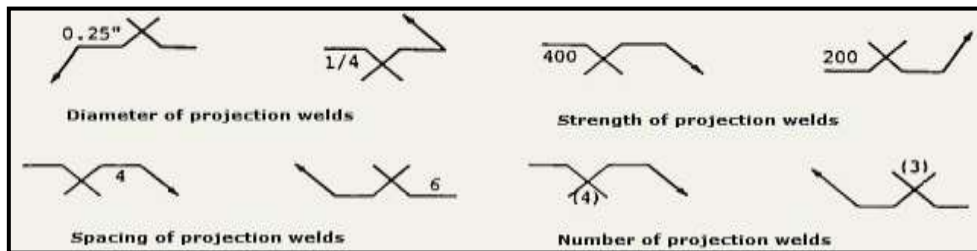

### 3.17. Flush Resistance Seam Welds:

When the exposed surface of one member of a resistance seam welded joint is to be flush, that surface shall be indicated by adding the flush contour symbol to the weld symbol, observing the usual location significance.

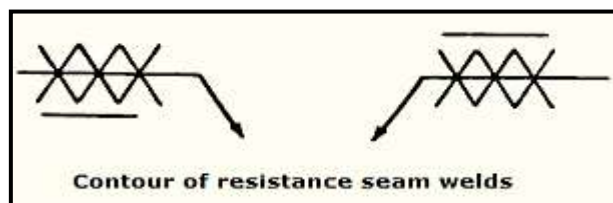

### 3.18. Inspection of Weld Profiles:

a. Convexity dimensions "C" of a weld or individual surface bead. Dimension "W" shall not exceed the value of the following table, below:

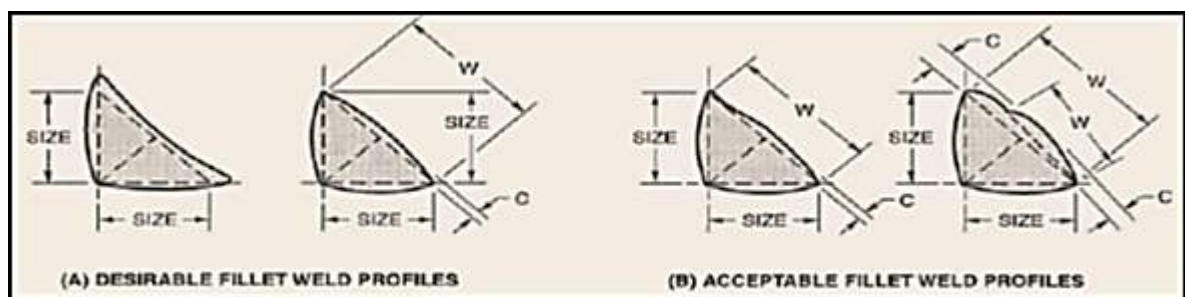

Width of weld face or individual surface bead, W	Max Convexity, C
$W \leq 5/16$ in.	1/16 in.
$W > 5/16$ in.	1/8 in.
$W \geq 1$ in.	3/16 in.

b. Root openings for "T" weldings:

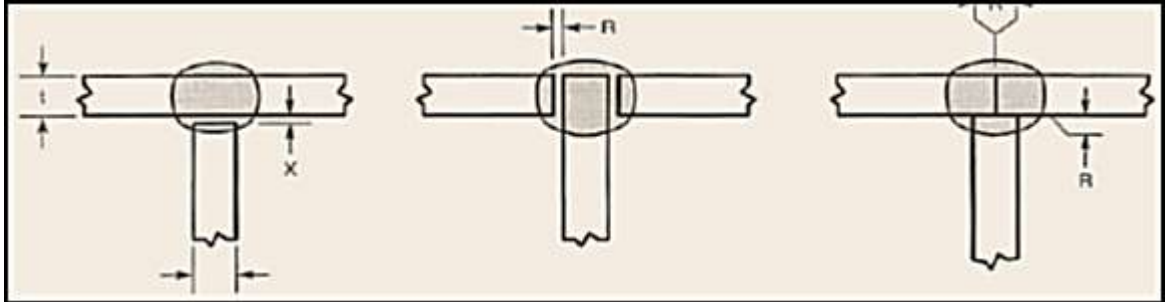

**Legend:**

t = Thickness of thinner member

R = Root opening  $\leq .010''$  for  $t < .100''$ ,  $\leq .030''$  since  $t \geq .100''$

X = Weld penetration: Min =  $1/2t$  or  $.015''$ , whichever greater, Max =  $2-1/2t$  or  $.187''$ , whichever less.

c. Evaluation of bead welds:

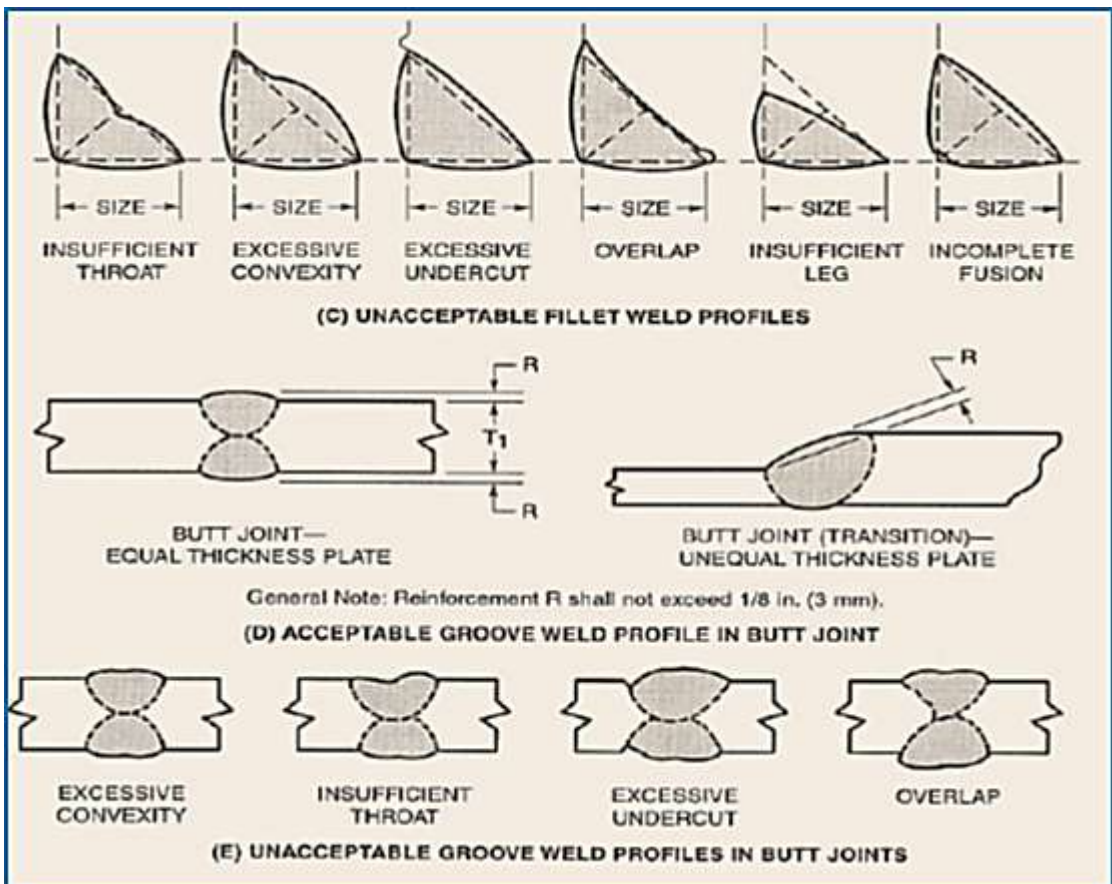

## IV - STANDARDS FOR WELDING POSITIONS:

It is very important for the Weld Inspector **to know the position**, or location of a joint relative to the horizon, because it may determine what welding process, methods, and techniques can be used.

Welding is usually easiest when the welder can work on a joint located on a flat, horizontal surface, such as on a table or bench. However, joints in the field may be located in a variety of positions relative to the welder and to the horizon, as shown below.

### 1) Welding positions - AWS D1.1, European Welding Standard EN 287 – 1, ASME IX:

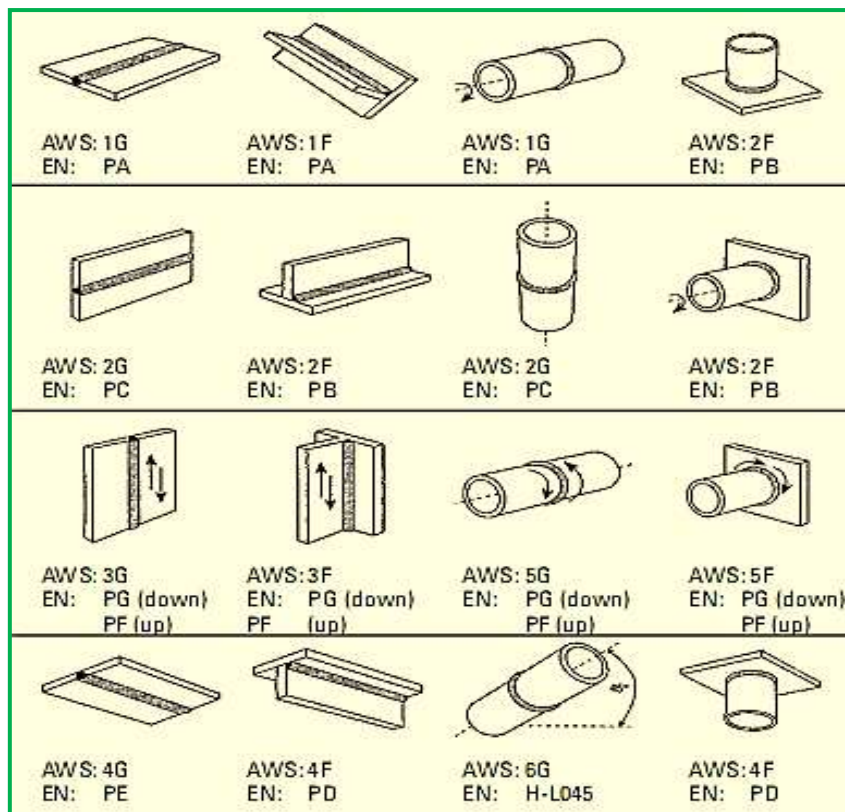
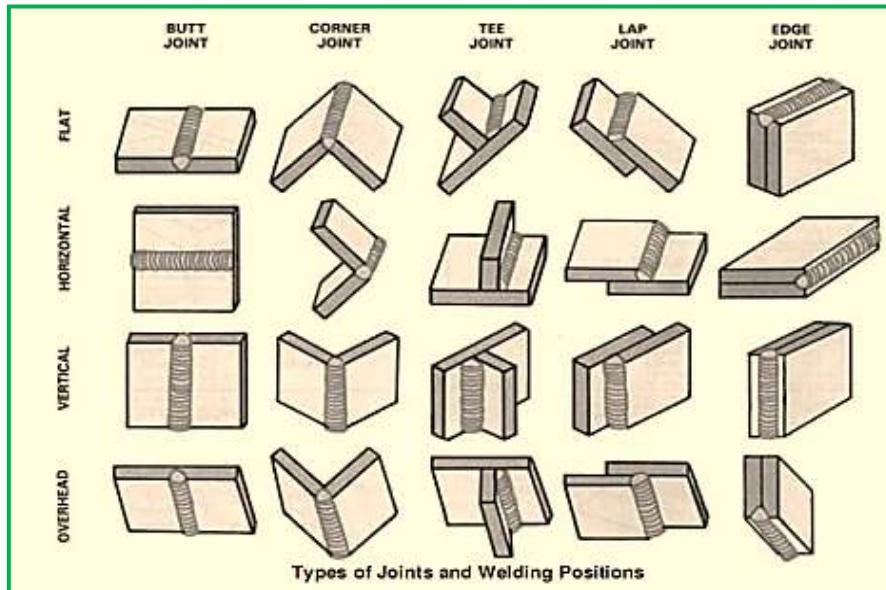

## 2) Welding Positions - Butt, Fillet and Piping Welds:

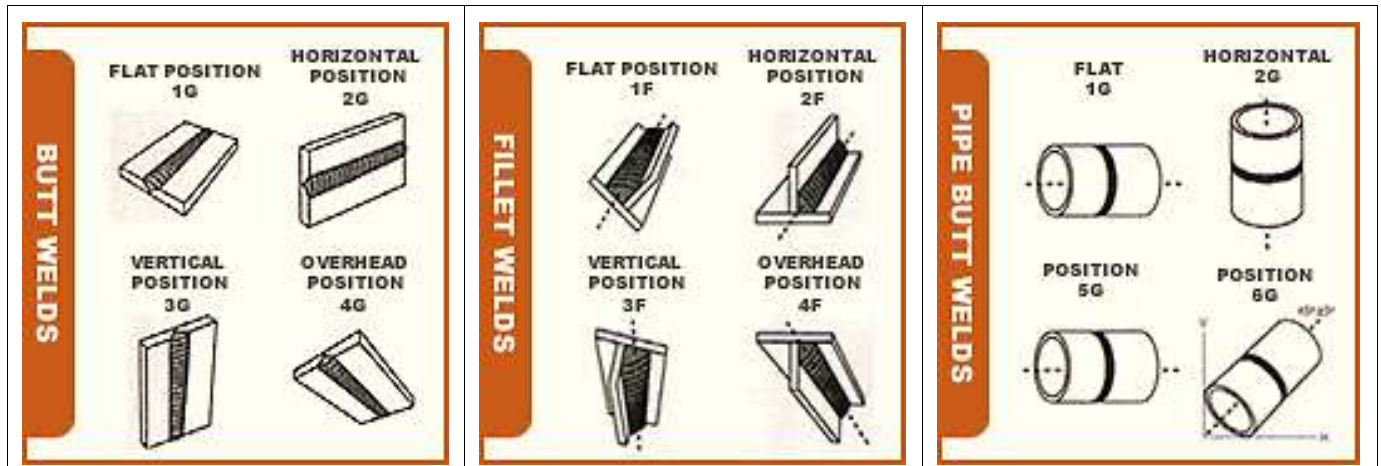

- **Flat Butt Weld Position - 1G:**

In this position, the axis line of the weld must **not incline more than 15°** from the horizon and the face of the weld must be on top. Welders often refer to the flat-position welding by the nonstandard term ***downhand welding***.

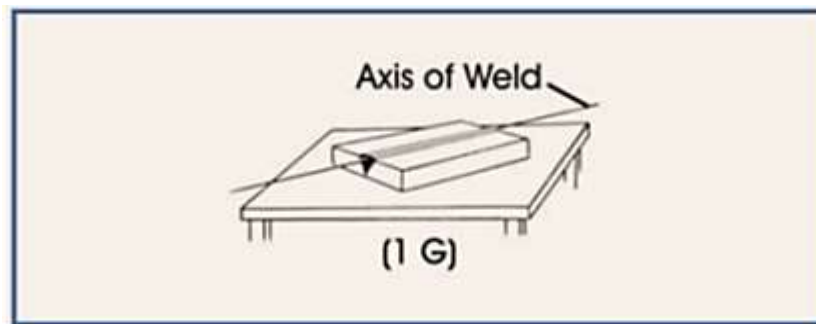

- **Horizontal Butt Weld Position - 2G:**

In this position, both plates are perpendicular to the bench top, but the axis of the weld remains horizontal. The lower surface of the groove helps somewhat to hold the molten weld metal in place.

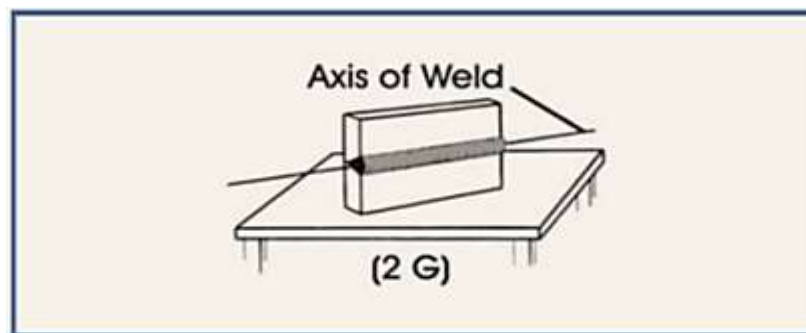

- **Vertical Butt Weld Position - 3G:**

In this position, the axis of the weld is perpendicular to the bench top and more difficult than in the flat and horizontal positions. The two plates and the axis of the weld are inclined more than 15° in reference to the horizontal bench top.

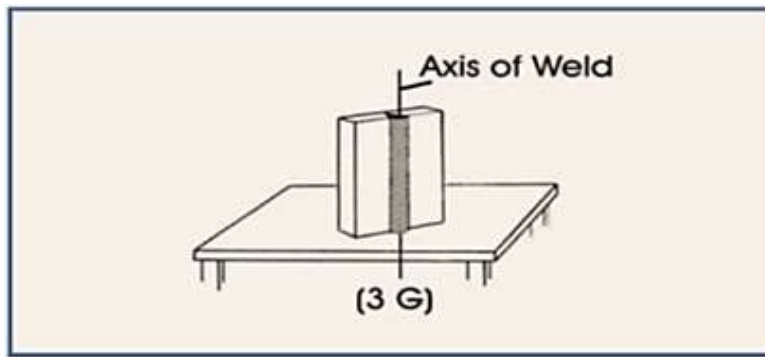

- **Overhead Butt Weld Position - 4G:**

In this position, the axis of the weld and the plates are horizontal, but the face for welding is downward. Welding in the overhead position is very difficult because there's nothing to help overcome the force of gravity. A welder must have a high degree of skill to make sound welds consistently in this position.

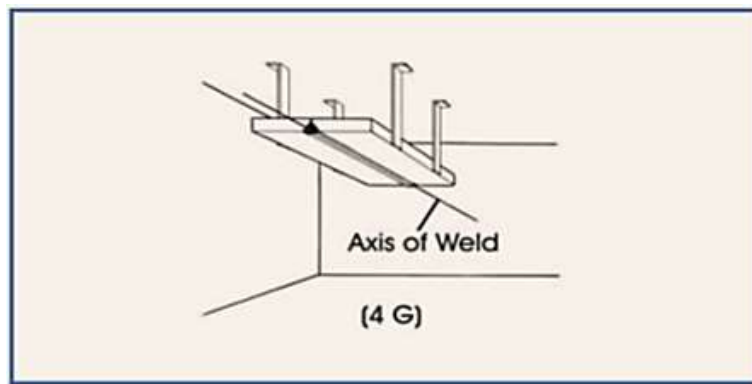

### 2.1) Fillet Welds and Their Positions:

The advantage of the fillet-welded joint is that it's unnecessary to prepare the edges of the plates or sheets for welding. Double fillet-welded joints are an improvement over single-fillet joints because they can withstand loads from more than one direction. Three of the five basic types of joints - **the lap, the T-joint and the corner joint** - can be joined with fillet welds.

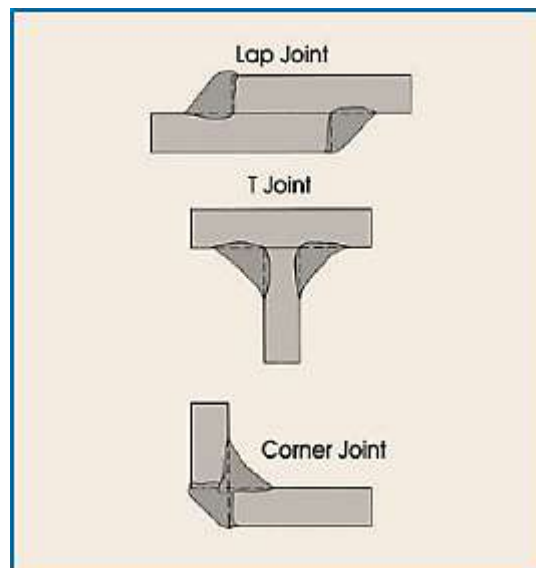

- **Flat Fillet Weld Position – 1F:**

The axis of the flat position fillet weld is either horizontal or inclined not more than 15° to the horizontal. The surfaces of the plates are each inclined at about 45° to the horizontal. The face of the weld is on top. The typical flat-position fillet weld is similar to the flat-position groove weld. The difference is in the positions of the plates forming the joint.

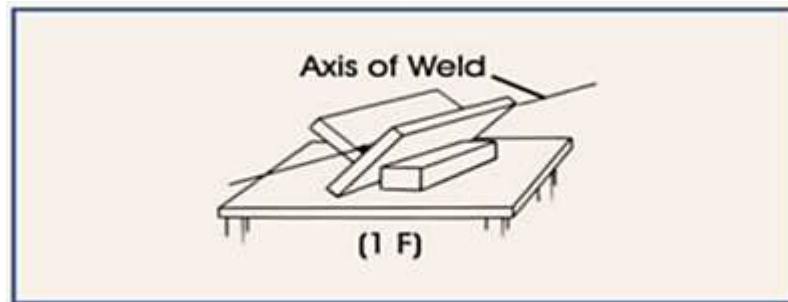

- **Horizontal Fillet Weld Position – 2F:**

In this position, both the axis of the weld and the lower plate of the joint assembly are horizontal. For the **T-joints and inside corner joints**, the other plate **is vertical**. For **lap and outside corner joints**, only the edge of the other member **is vertical**.

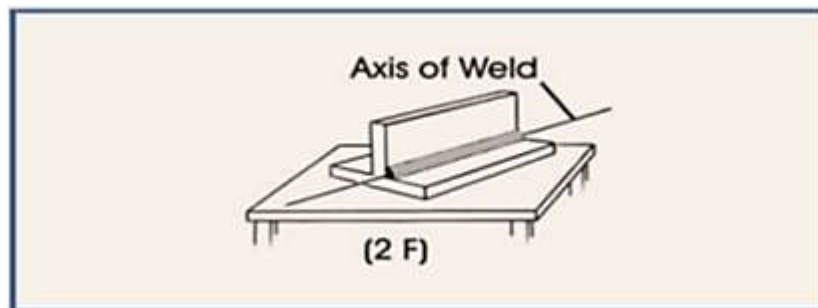

- **Vertical Fillet Weld Position – 3F:**

The plates and the axis of the fillet weld are perpendicular to the bench top. Vertical fillet welding is a difficult operation requiring a high degree of skill. Vertical fillet welds may be deposited by progressing **from the bottom up or from the top down**.

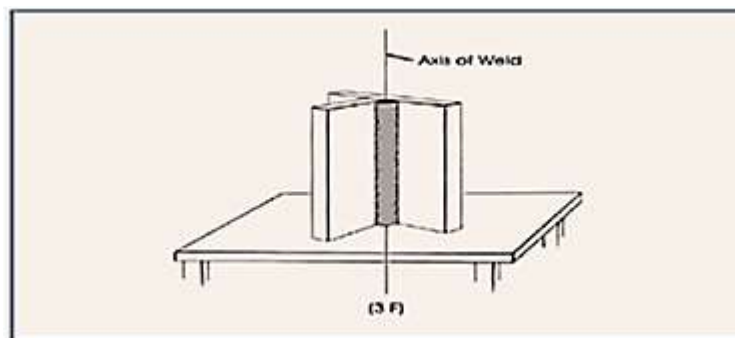

**Note:** Welders should be tested according to a qualified Weld Procedure Specification (WPS). However, welding vertically in a downward progression does not fit within the guidelines of AWS D1.1-2010, Clause/Sub-section 3.7.1).

- **Overhead Fillet Weld Position – 4F:**

Overhead position fillet welds are basically horizontal-position fillet welds turned upside down. The axis of the weld is horizontal, and the plates are usually vertical and horizontal. This is another difficult welding position because there's nothing to hold the molten metal against the force of gravity.

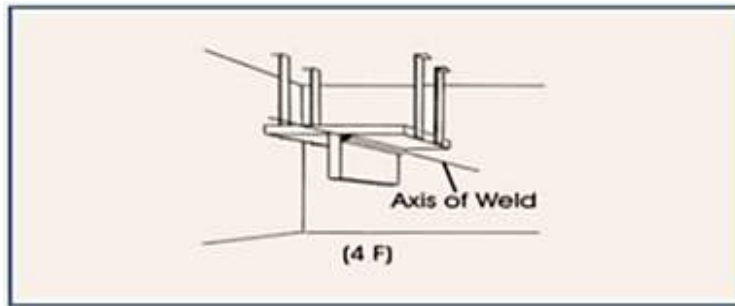

## 2.2) Positions for Welding Pipe:

For welding pipe in shops, power plants, oil refineries, and chemical plants for crude oil, gasoline, and natural gas, the same basic welding positions described previously are used.

- **Flat Butt Weld Pipe Position – 1G:**

A pipe to be welded in the flat position **is usually placed on roller dollies or wooden skids**. As the pipe is welded, it's rotated on the dollies or skids. This procedure **is the same as the flat position plate welding**. The speed of rotation should be the same as the welder's forward welding speed.

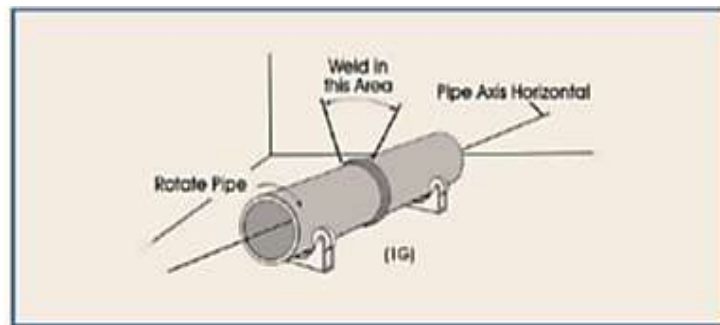

- **Horizontal Butt Weld Pipe Position – 2G:**

In this position, the weld around the vertical pipe **is the same of a horizontal position plate welding**. There is little difference whether the pipe is rotated or fixed because the welding is the same. The welder will circle around the joint or the pipe itself can be turned in a circle, free to rotate.

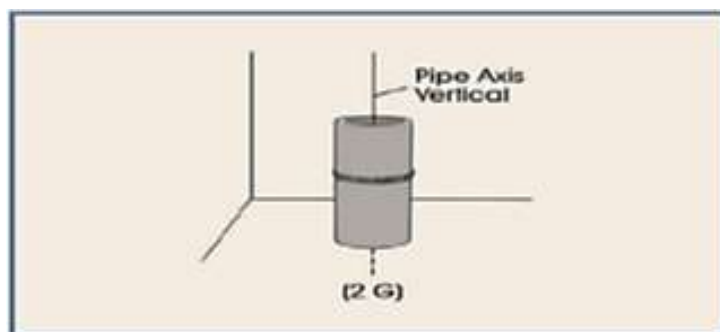

- **Multiple Butt Weld Pipe Position – 5G:**

In this position, the axis of the pipe is horizontal, but can't be rotated. As the welder works around the pipe to make the weld, he or she must weld in a number of different positions.

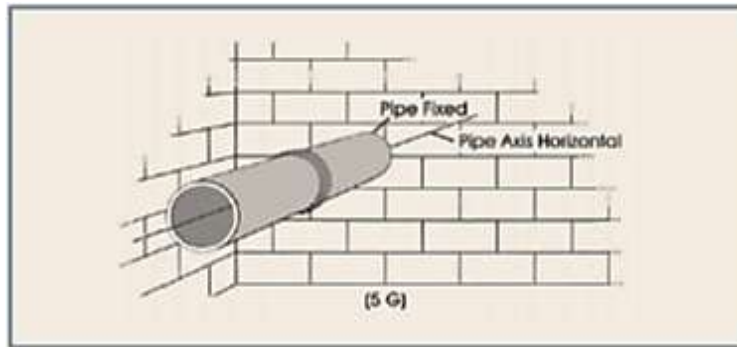

- **Multiple Butt Weld in Angled Pipe Position – 6G:**

In this position, the axis of the pipe is at a 45° angle to the horizon. This position is used widely in testing welders' ability. Therefore, it's used as an all-position qualification test for pipe welders.

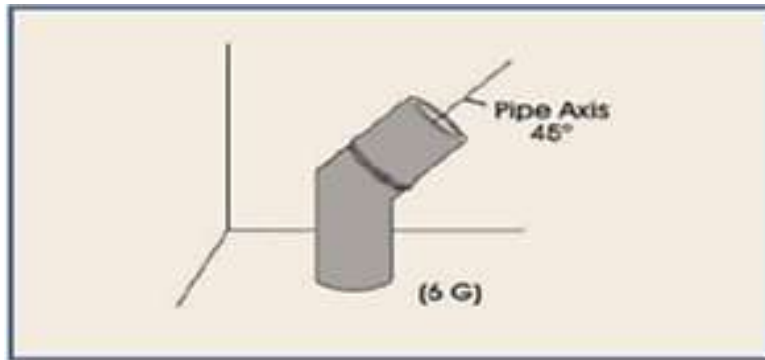

## V – WELDING PROCESSES:

The welding processes are not the scope of this manual, specific for welding inspections. However, only for refreshing, the most common **arc welding processes** used in heavy and medium carbon and alloy steel manufacturing are:

- **SMAW:** Shielded Metal Arc Welding - stick welding electrode;
- **GMAW:** Gas Metal Arc Welding or MIG welding - solid wire or metal cored wire;
- **GTAW:** Gas Tungsten Arc Welding or TIG welding - rod or solid wire.
- **SAW:** Submerged Arc Welding - solid or tubular wire;
- **FCAW:** Flux Cored Arc Welding - gas-shielded flux cored wire;
- **CAW:** Carbon Arc Welding
- **PAW:** Plasma Arc Welding

The steels commonly used in plate manufacturing, metallic structures and piping systems are covered by the specifications of ASTM, AISI, ASME, SAE, and API, and often refer to the same types of steels, although **different restrictions** on the **chemical analysis** and **mechanical properties**.

Commonly the most used materials for welded construction meet specifications conform to ASTM A 36, A 203, A 242, A 440, A 441, A 514, A 517, A 572 and A 588. For piping materials the main specifications are ASTM A 53, A 106, A 134, A 139, A 671, A 672 or A 691 or API 5L, 5LX, or 2H.



# General Welding and Allied Processes:

## ARC WELDING (AW)

Atomic Hydrogen Welding ..... AHW  
 Bare Metal Arc Welding ..... BMAW  
 Carbon Arc Welding ..... CAW  
 - Gas ..... CAW-G  
 - Shielded ..... CAW-S  
 - Twin ..... CAW-T

Electrode Gas Welding ..... EGW  
 Flux Cored Arc Welding ..... FCAW  
 Gas Metal Arc Welding ..... GMAW  
 - Pulsed Arc ..... GMAW-P  
 - Short Circuiting ..... GMAW-S  
 Gas Tungsten Arc Welding ..... GTAW

Gas Tungsten Arc Welding - Pulsed .... GTAW-P  
 Plasma Arc Welding ..... PAW  
 Shielded Metal Arc Welding ..... SMAW  
 Stud Arc Welding ..... SW  
 Submerged Arc Welding ..... SAW  
 Submerged Arc Welding - Series ..... SAW-S

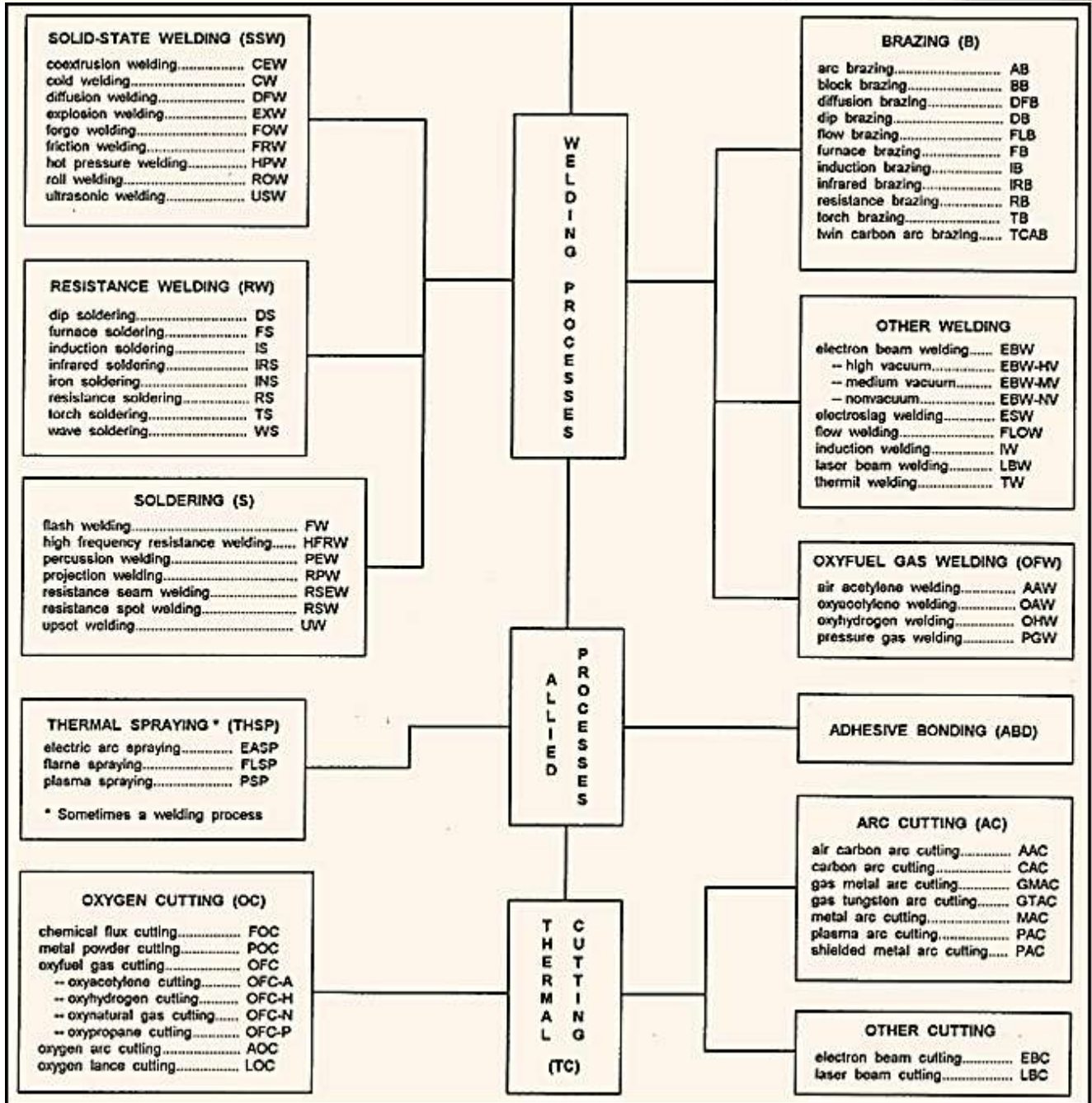

## 1. Welding of Stainless Steels:

### a) General Concepts:

Stainless steels, resumed here in a general way, are defined as steel alloys, where the **chromium content** ranges from **10.5% to 30%**. There are five distinct types of stainless steel:

#### **Ferritic stainless steel:**

Contains from **10.5 to 30% chromium**, is low in carbon, with some alloys containing major amounts of molybdenum, columbium and titanium.

#### **Austenitic stainless steel:**

Contains from **16% to 26% chromium** and up to 35% nickel and have very low carbon content. Some of these steels are also alloyed with a minor amount of molybdenum, columbium and titanium.

#### **Martensitic alloy steel:**

Contains from **12% to 17% chromium** and up to 4% nickel and 0.1% to 1.0% carbon. Some alloys will also have minor additions of molybdenum, vanadium, columbium, aluminum and copper.

#### **Duplex stainless alloys:**

Contain **18% to 28% chromium**, 2.5% to 7.5% nickel and low carbon contents. Some of the alloys will also have additions of nitrogen, molybdenum and copper.

### b) Welding Processes:

All stainless steels are commonly welded by **SMAW, GMAW, FCAW, and SAW** processes. **GTAW** is also commonly used, but it is a slow process. The most used process is SMAW because the equipment is portable and easy to use.

Processes by GMAW, FCAW, and SAW are being used more often because they are economical and produce high quality welds. The manufacturers' recommendations for welding stainless steels include joint designs, preheat temperatures, associated post-weld heat treatment and shielding gas.

### c) Joint Design:

Weld joints are prepared by plasma-arc cutting, machining or grinding, depending on the alloy. Before welding, the joint surfaces must be cleaned of all foreign material, such as paint, dirt, scale, or oxides.

Cleaning may be done with suitable solvents and light grinding. Care should be taken to avoid nicking or gouging the joint surface since such flaws can interfere with the welding operation.

### d) Passivation of Stainless Steels:

The Welding Inspector should understand the **meaning** of stainless steels **passivation**. Passivation is a post-fabrication cleaning method of maximizing the inherent corrosion resistance of stainless steels. It is not a scale removal treatment, nor is it like a coat of paint.

The passivation treatment is also designated by "**pickling**" and is simply the removing iron contamination with nitric acid, citric acid or hydrofluoric acid mixtures. Stainless steels cannot be passivated unless the steel surface is clean and free of scales from welding operations.

Citric acid is a less hazardous method and has environmental benefits in terms of 'NOx' fume emission and waste acid disposal. Solution strengths of **4-10% citric acid** are specified for passivation treatments in ASTM A967.

The passivation treatment specifications for stainless steels are:

- ASTM A380 - Practice for Cleaning, Descaling and Passivation of Stainless Steel Parts;
- ASTM A967 - Specification for Chemical Passivation Treatments for Stainless Steel Parts.

## 2. Low and High Alloy Steels:

### a) General Concepts:

Alloy elements are metals such as manganese (Mn), chrome (Cr), nickel (Ni), molybdenum (Mo). Carbon (C) is not an alloy element. Low alloy steels contain 1–5% of alloy elements. High alloy steels contain more than 5% of alloy elements.

### b) Welding Processes:

Low and high alloy steels can be welded by SMAW, GMAW, FCAW, and SAW processes. GTAW is also commonly used, but it is a slow process. The most used process is SMAW because the equipment is portable and easy to use.

## 3. Heat Resistant Steels:

Heat resistant steels are a low alloy steel, alloyed with a certain percentage of molybdenum (Mo) and sometimes also chromium (Cr). The addition of these alloying elements imparts heat resistant characteristics and the steel retains its strength at high temperatures. These types of materials can also be welded by SMAW, GMAW, FCAW and SAW processes, commonly used in boiler tubes, boiler plates and high pressure pipes.

AWS D1.1 contains a selection guide to match electrode types with various ASTM and API steels. Recommendations should be followed when developing the welding procedures, heat-treatment and stress-relief for **high strength low alloy steels** conforming to ASTM A 514, A 517, or A 710.

## VI. WELDING INSPECTION PROCEDURES:

### 1. First Inspection Verification:

The main job of Weld Inspectors is to judge the quality, integrity, properties, testing, dimensions procedures and recording of welding operations. All weldings must be done by a certified welder. When the a welder is qualified a **certificate is issued** showing the types of welds which the operator is qualified to perform. Inspectors should verify and record the welder's certificate:

- Certificate number,
- Date issued, and
- Qualified positions on the Log of Piling form.

Certificates are good for one year and must be renewed annually, except requalification that will be only be required every two years for field welder who have successfully passed their qualification tests without failure for three consecutive years.

Welding and repairs shall be done in accordance with **Welding Procedure Specifications (WPS)** but, only Shielded Metal Arc Welding (SMAW) and/or Flux Cored Arc Welding (FCAW) will be permitted for welding steel piles.

Filler metal shall be in accordance with the requirements of AWS Specifications. For SMAW, **low hydrogen electrodes** shall be used. The welding electrode must be on the approved list published by the Office of Materials semi-annually or be specifically approved by the Office of Materials.

All welding **electrodes and storage** system should be checked. The electrodes should be **kept dry** and protected from humidity. Welding surfaces shall be cleaned with a grinder or a wire brush, free of scale, slag, rust, moisture, grease and any other foreign material to prevent improper welding.

## 2. Weld Defects Inspection:

The most important considerations in inspection are to point out the difference between a **weld defect and a weld discontinuity**. However, some welding instructors, specification books or codes may allow for a certain amount of discontinuities without calling the weld defective.

A defective weld in a manufacturing situation would have to be ground out and replaced or the entire base metal structure would be rejected. When one or more discontinuities cause a weld to fail a particular weld test, this type of discontinuity would then be termed as a defect.

It is quite easy to encounter many kinds of discontinuities and defects when first learning the GMAW process. Discontinuities and defects can be caused by many factors, including:

- Improper welding techniques;
- Improper shielding gas or equipment problems;
- Improperly prepared or contaminated base metal;
- Dirty or contaminated electrode wire;
- Improper secondary circuit;

The most common weld defects are:

- Lack of Penetration;
- Incomplete Fusion;
- Porosity;
- Undercutting;
- Cracking;
- Excessive Spatter;

### 2.1. Incomplete Fusion (Cold Lap):

Fusion is how well the base metal and weld metal are joined together and is very important to a full strength of a joint. Incomplete fusion means that at some point in a weld the base metal and weld metal have not been joined properly.

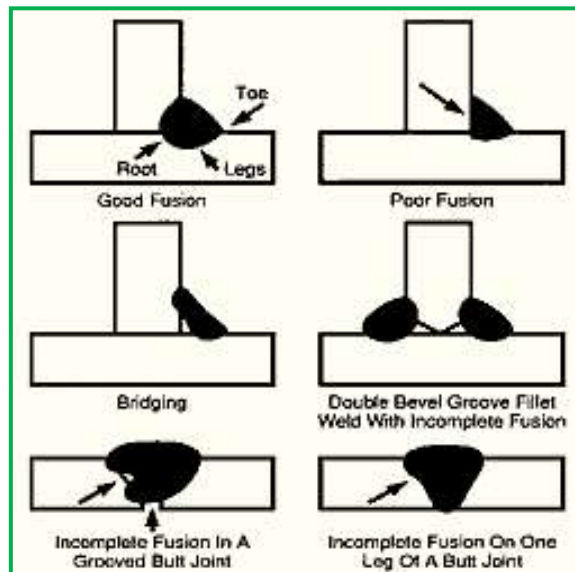

The possible causes are:

- Failure to raise the temperature of the weld area to the correct level;
- Failure to remove large amounts of mill scale, oxides, or any other foreign materials;
- Materials could hinder the fusing of the weld metal to the base metal;
- Improper joint design to the size of the groove angle and root openings on a butt joint;
- Angles or openings too small for proper electrode extension;
- Gas shielding and incomplete fusion operation.

**Obs:** A good weld is not stronger than its weakest point.

## 2.2. Lack of Penetration:

When the molten weld metal has not sufficient penetration into the base metal, a weld defect occurs, called lack of penetration. Poor fit-up of the welding equipment brings difficult in bead penetration.

## 2.3. Porosity:

Porosity is a cavity in the weld formed by gas escaping from the molten weld during solidification. It can occur at the surface of the weld or inside the weld, where it is difficult to detect. Subsurface porosity cannot be seen with the naked eye but can be detected with various means of testing. The AWS D1.5 specification for porosity is:

- Maximum diameter shall not exceed 3/32 inch;
- Frequency of any sized porosity shall not exceed one in 4 inches or six in 4 ft. of weld length.

Porosity looks like many small holes in a weld, much like the worm holes in a piece of wood, gas pockets or pores, usually round in shape and can vary in size. The primary sources for porosity are:

**Moisture:** The moisture is heated by the welding arc and molten metal, and becomes a gas. Hot metal absorbs some of this gas but the rest of it, being lighter than the metal, floats out into the air.

**Dirty wire or base metal:** Electrode wire containing any foreign matter can cause porosity, as oils or other foreign materials can cause poor welds. Electrode wire should thus be kept as clean as possible.

**Trapped gases:** Hot metal absorbs more gas than cold metal. Therefore, as the weld bead begins to cool, the gas can no longer stay in the cooling metal and must come out.

**Metal cooling:** When the metal cools before the gas has a chance to fully escape from the weld, it becomes less liquid and the escaping gas is then trapped, causing porosity. The sources to be checked are; contaminated electrodes, wet base metal, excessive humidity or any moisture in the air.

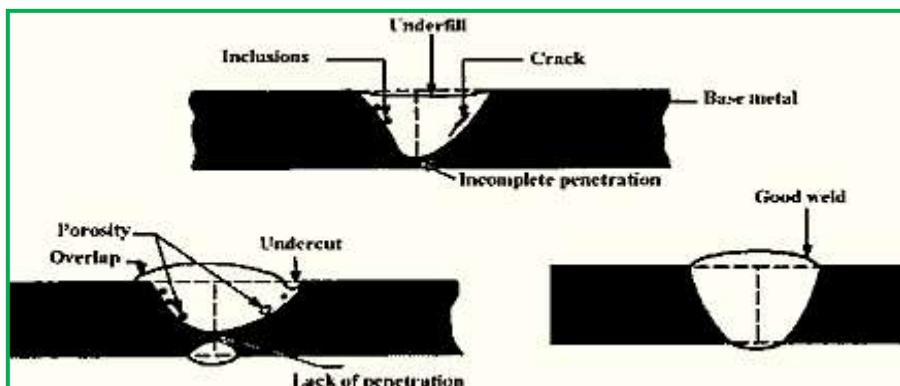

## 2.4. Undercutting:

Undercutting is a defect that appears as a groove in the parent metal, directly along the edges of the weld, caused by excessive current in the welding operation, improper welding parameters, travel speed and arc voltage. When the travel speed is too high, the weld bead is peaked because of its extremely fast solidification. The surface tension draws the molten metal along the edges and piles it up along the center.

The undercut groove does not wet back properly, because of the rapid solidification. Decreasing the arc travel speed, raising the arc voltage or using a leading torch angle, will gradually reduce the size of the undercut and eventually eliminate it.

The AWS D1.5 requirement for undercut is:

- Undercut shall be no more than 0.01 inches deep when the weld is transverse to tensile stress;
- No more than 1/32 inch deep in both cases.

**Example:** If a cross-frame angle is welded into the web of a beam, then the allowable undercut along the edge, is no more than 0.01 inch.

## 2.5. Craters:

Craters are the ends of welds where the weld is not filled to its full cross section. The stresses are formed because of tension on the weld in the affected area. All welds must be fulfilled in the cross section of the entire length of the weld.

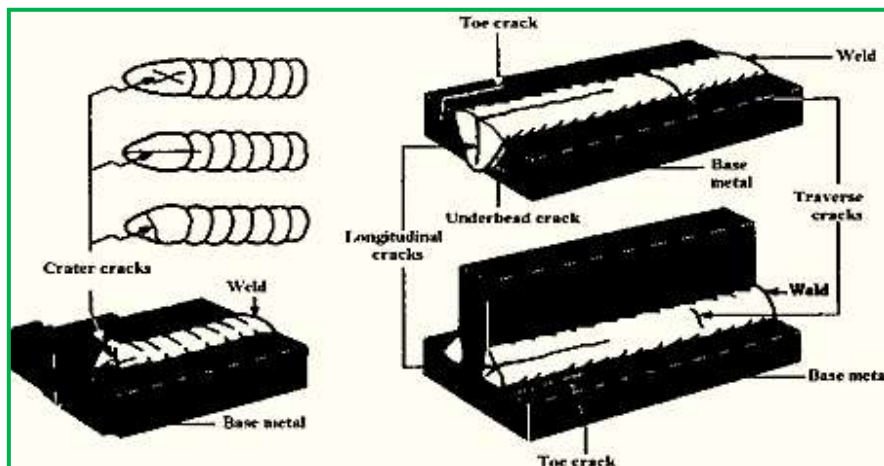

## 2.6. Cracking:

If a crack is found, it must be removed and magnetic-particle inspection performed to ensure every point has been removed before re-welding. Cracks can occur on top of a weld bead, within the weld, or in the base metal.

GMAW electrode wires are low hydrogen in content and have no flux coating to attract moisture, can help avoid cracking in the weld and heat-affected zones, if kept clean and dry. Spools or reels must be free of moisture both while being used and when being stored.

A crack can easily occur on welding of aluminum, due to metal contraction as the weld pool cools, while the base metal remains hot. Cracks may be more numerous with aluminum, but they may also occur in stainless steel and galvanized materials.

Cracks may occur if excess heat input is used for the particular thickness of material being welded, or steels with high carbon content, over 30 %, are likely to crack due to their hardness.

## 2.7. Spatters:

If there are a lot of spatters resulting from a weld, other problems could be occurring, possibly causing a weld defect. Low voltage or high wire feed speeds, could also be the cause of a weld defect such as incomplete fusion. Many electrode manufacturers prepare their electrode wires with various alloys and coatings to help provide fewer spatters. Dirt or rust on the electrode wire can also be a cause for excess weld spatter, as well as dirt or rust on the base metal. The considerations are:

- The shielding gas selected in a particular situation can cause spatter. CO<sub>2</sub> shielding gas is generally considered to yield more spatter in mild steel than a mixture of Argon + CO<sub>2</sub>, or a mixture of Argon + O<sub>2</sub> for spray arc welding.
- The gas flow rate, set on the regulator/flowmeter, should also be considered. Excessive gas flow rates can cause a turbulent, unstable arc, which also can cause spatter.
- Spatter can also form on the gun nozzle and contact tube blocking, gas flow and improper volt-amp (WFS) parameters can also cause problems. Certain compounds are available to apply to nozzles so that spatter will not adhere as easily.
- If a drag or push angle is being used, too much of an angle can lead to spatter, because the arc is not properly directed below the nozzle, as it would be with a proper angle, 5-10 degrees.
- Too much electrode extension, can also cause spatter due inadequate shielding gas, as well, improper melting of the electrode, due to the longer preheating time for the electrode wire.
- Too fast of a travel speed can also cause spatter because the molten metal deposited is not given enough time to properly wet out.

## 2.8. Arc Strikes:

Arc strikes happen when the welding electrode comes into contact with the base metal outside of the final weld. Arc strikes result in heating and very rapid cooling. Arc strikes may result in hardening or fatigue cracking, and serve as potential sites for fracture initiation.



Arc strikes should be **removed by grinding** to a depth of 1/8 inch below the original surface removing all traces of arc strikes and their hardened heat-affected zones.

However, in tension areas, the locations where arc strikes were removed should have **Magnetic-Particle inspection** and hardness testing performed per AWS D1.5 Welding Code.

### 1.1. Weldment Defects:

Weldment defects can be classified into three groups:

1. Drawing or dimensional variations;
2. Structural discontinuities within the weld;
3. Physical or chemical properties of the weldment.

#### a. Drawing or Dimensional Defects:

The making of satisfactory welds in regard to dimensional defects depends upon keeping within the specified dimensions for the size, shape of welds and finished dimensions of the product. Dimensional defects and must be corrected before the final acceptance of the weldment can be made.

#### b. Incorrect Joint Preparation:

Established welding procedures require proper joint dimensions and preparation for each joint according to the thickness of the material being welded. Therefore it is very important that all joint preparations are the same as shown in the specifications. (Figure 1, below).

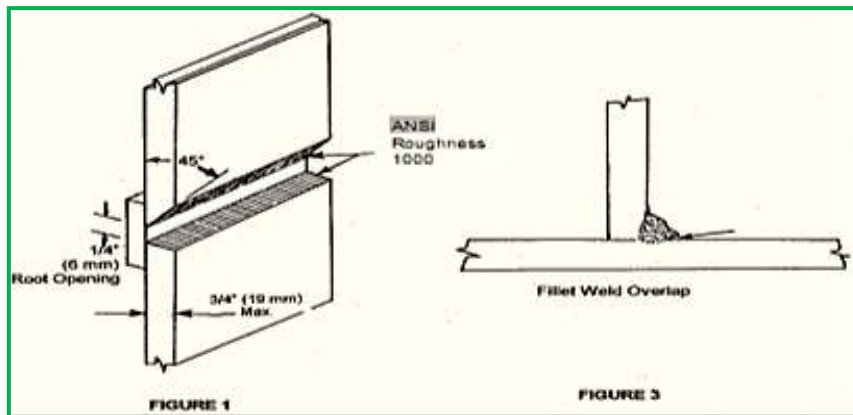

#### c. Incorrect Weld Profiles and Sizes:

The profile of a finished weld can have a considerable effect upon its performance under load. The profile of one layer of a multipass weld can have an effect on the next pass in that it may cause slag inclusions or incomplete fusion to occur between the passes.

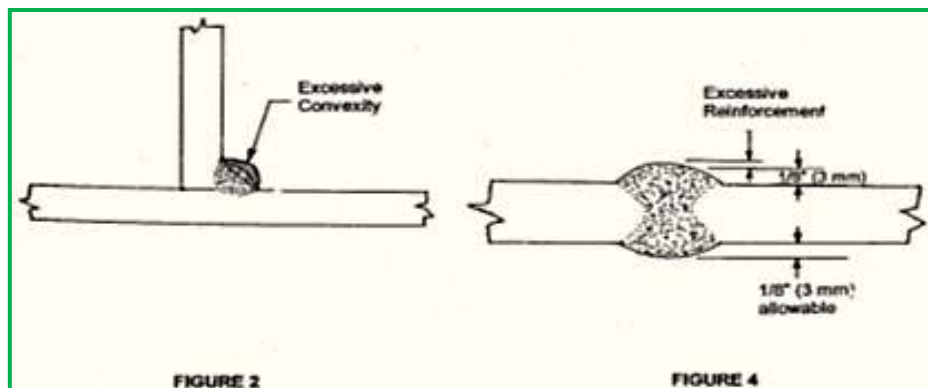



Excess convexity, like overlap, tends to produce notches. Excess convexity is also harmful in the case of an intermediate pass in a multi-layer groove weld, because slag inclusions or incomplete fusion can occur on a succeeding pass if corrective measures are not taken. (Figure 3, above). It is considered defective welding because the effective size of the fillet is reduced. Overlap is generally caused by improper welding technique or by improper electrical conditions.

Excess concavity is usually associated with fillet welds and this condition is usually caused by excessive welding currents or arc lengths. Excessive weld reinforcement is also undesirable since it tends to stiffen the section and help create undesirable stress concentrations. (Figure 4, above). The inspector should look for overlap conditions primarily on the lower leg of fillet welds, but it can also be found at times on the last pass, or reinforcement pass of groove welds. (Figure 2, above).

## 1.2. Concepts of Welding Defects and Discontinuities:

These defects can be classified as structural discontinuities and consist of: porosity, slag inclusions, lack of fusion, cracks, etc.

**a. Porosity:** Is gas pockets or voids in the weld metal which are free of any solid materials, such as slag. It is formed as a result of gases driven from the weld metal, excessive currents, excessive arc lengths, and improper preparation of the joint.

Porosity is generally classified into different groups as follows: **scattered, clustered and linear.**

- Scattered porosity occurs throughout the weld metal and the voids may vary in size from microscopic to slightly over 1/8 in.(3 mm). (Figure 6, below);
- Clustered porosity occurs in groups and may generally be associated with a change in welding conditions. (Figure 7, below);
- Linear porosity occurs throughout the length of a weld and the voids are in a line with respect to the axis of the weld. This type of porosity generally comes in the root pass and usually can be traced to the inadequate preparation of the joint. (Figure 8, below).

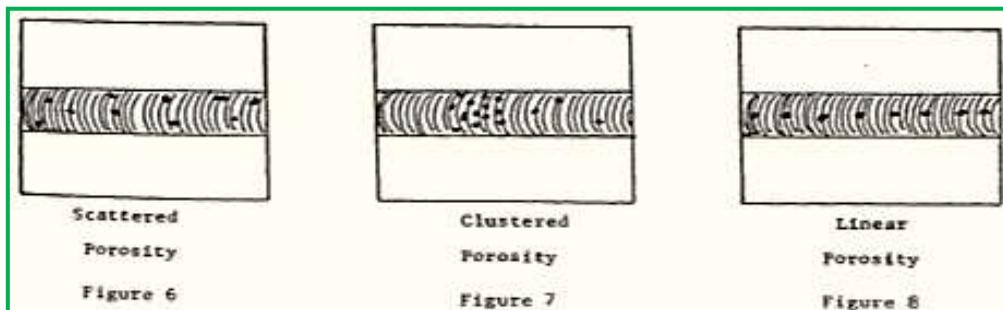

**b. Slag inclusions:** Can also form on a root pass of a V-groove weld, if the root opening is too small to permit the arc to heat the bottom of metal to a high enough temperature and allow the slag to float to the surface.(Figure 9, below). The welder can create similar conditions to this, by having undercutting or excessive convexity in a weld bead, or using too large an electrode in the root pass.

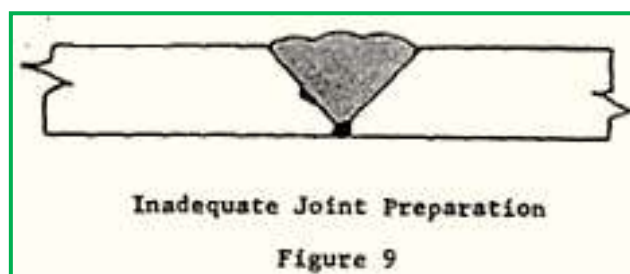

The inspector should realize that most slag can be prevented when the welder uses good sound welding practices, such as: proper preparation of the groove before each weld bead, be careful in correct contours inside specifications and the use of preheat to retard the weld metal solidification.

**c. Lack of fusion:** Is either the failure of raising the temperature of the base metal out of the fusing point or the failure to dissolve the oxides by fluxing. Check the incomplete fusion by ascertaining the surfaces to be welded, whether are free of all objectionable material. (Figure 10, below).

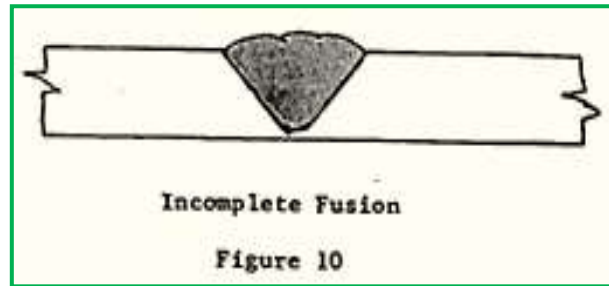

Most lack of fusion is due to inadequate joint preparation and to a heat transfer condition at the root of the joint rather than a failure to dissolve or flux surface oxides. When the portion of the base metal closest to the electrode is distant from the root, the heat transfer has to be made by conduction, which may be insufficient to attain the fusion temperature at the root.

**d. Undercutting:** Is used primarily to describe the reduction of the base metal thickness at a line where the last bead of weld metal is fused to the surface or at the toe of a weld. It can occur on V-grooves, fillet weldings and on the vertical leg of a horizontal fillet.

Undercutting of both types is usually due to a technique employed by the welder, although magnetic arc blow can also be a factor. Undercutting can be detected by visual inspection and a tolerance for it has been set up in the AWS under the Article, "Weld Profiles." (Figure 11, below).

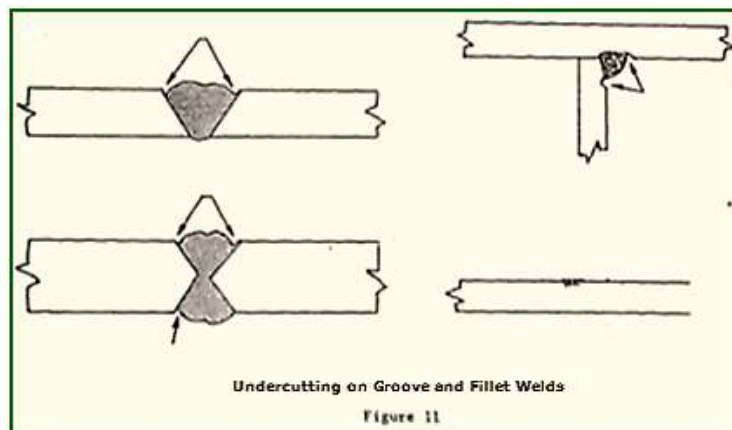

**e. Cracks:** Are results of a localized stress that at some point has exceeded the ultimate strength (UTS) of the material. The well-known causes of cracks are:

- The wrong use of electrodes, improper electrical conditions, travel speed and lack of preheat. Different types of cracks are: transverse, longitudinal, crater and base metal. The first three types are usually visible cracks that are easily found.
- The base metal cracks are much more difficult and test methods may be required to discover them. Like the name implies, the cracks are in the base metal and sometimes are under the weld bead. (Figure 12, below).

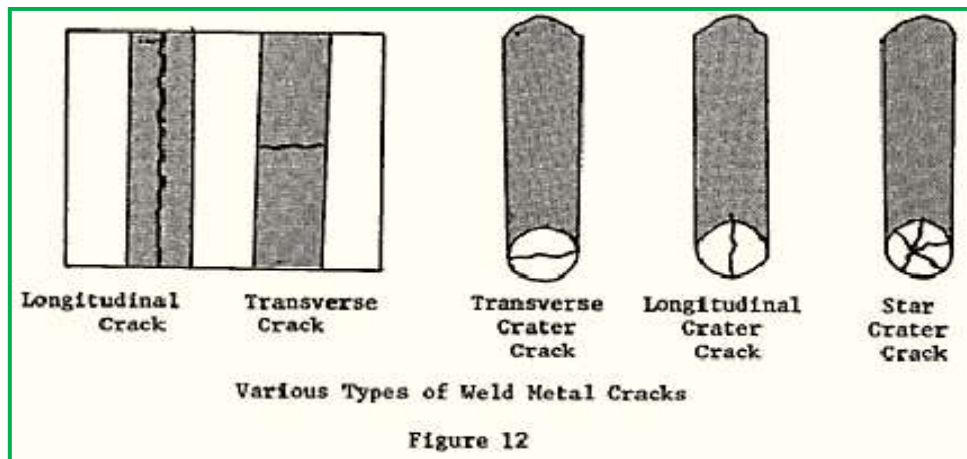

**f. Crater cracks:** Are small and usually star-shaped and found in the weld crater itself. They start at the center of the crater and extend out to the end. Crater cracks are not detrimental to the weld, when there are good conditions to be repaired.

Various types of surface irregularities may occur during welding. These irregularities can vary from actual holes in the weld to surface roughness of the metal or excessive spatter. Improvement of these conditions is usually obtained by changing the electrical conditions.

Good welding practice dictates the removal of crater cracks by grinding or chiseling. The surface appearance of the weld generally reflects the ability and experience of a welder. However, good welding, but poorly finished should not be refused, except under unusual conditions or the integrity of the job is necessary and beyond question.

## 2. Incorrect final dimensions:

**a. Inspector and Welder:** Must be aware of how much shrinkage can be expected at each weld joint and how much warpage will occur in the joint. If the inspector visualizes the welding of a simple V on a simple plate and knows that the welding heat causes shrinkage in each pass, then they can also visualize the ends of the plate curling up.

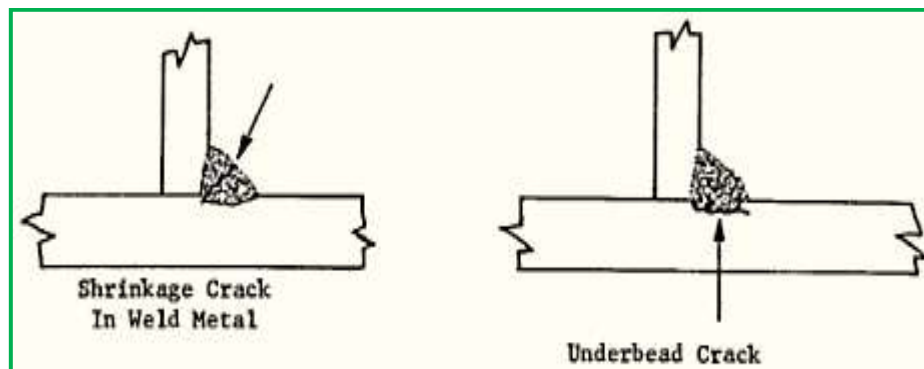

**b. Heat Shrinkage Stresses:** Tend to produce cracking. On welds that are designed to prevent shrinkage and warpage or restricted by manual devices, it is obvious that while shrinkage occur, the stresses tend to produce cracking.

**c. Drawings Review:** The inspector should review the drawings to determine which dimensions are critical and then discuss the weldment dimensions and tolerance with the welder so he/she will devote major efforts to these critical areas. (Figure 5, below).

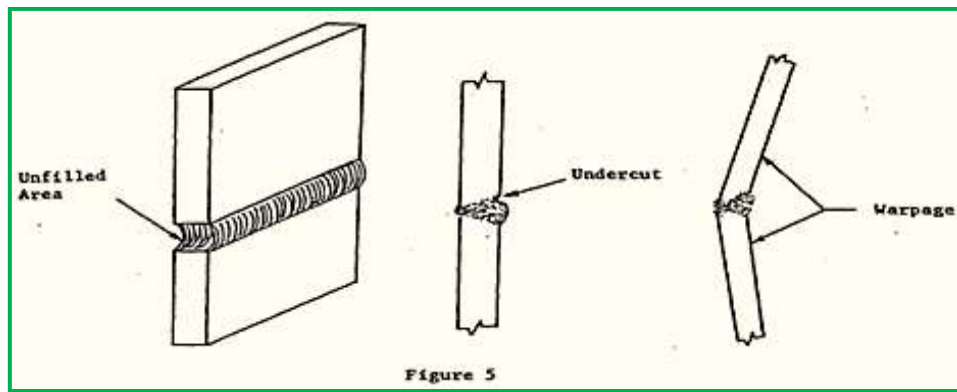

### 3. Nomenclature of Welds:

**a. Fusion Zone.** The fusion zone is the area of base metal melted as determined in the cross section of a weld. (Filler Penetration)

**b. Leg of a Fillet Weld.** The leg of a fillet weld is the distance from the root of the joint to the toe of the fillet weld. There are two legs in a fillet weld.

**c. Root of the Weld.** This is the point at which the bottom of the weld intersects the base metal surface, as shown in the cross section of weld.

#### d. Sizes of the Weld.

- Equal leg-length fillet welds. The size of the weld is designated by leg-length of the largest isosceles right triangle that can be scribed within the fillet weld cross section.
- Unequal leg-length fillet welds. The size of the weld is designated by the leg-length of the largest right triangle that can be inscribed within the fillet weld cross section.
- Groove weld. The size of the weld is the depth of chamfering plus the root penetration when specified.

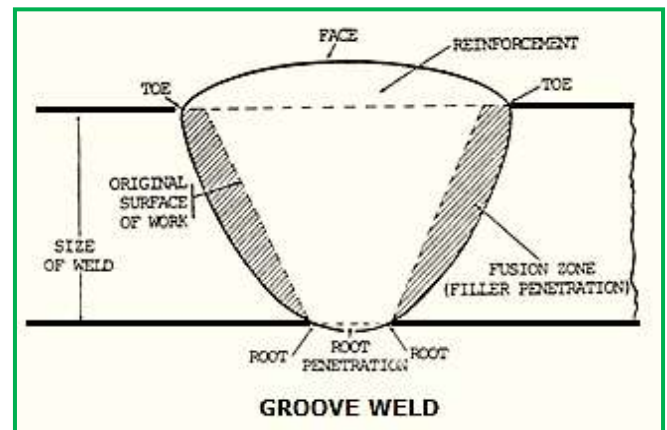
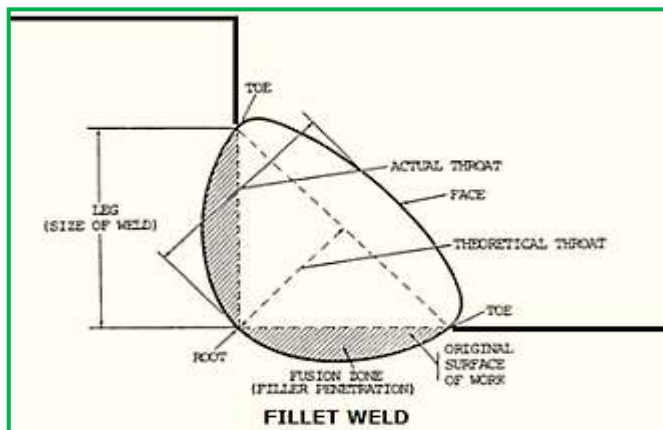

#### e. Throat of a Fillet Weld.

- Theoretical throat. This is the perpendicular distance of the weld and the hypotenuse of the largest right triangle that can be inscribed within the fillet weld cross section.
- Actual throat. This is distance from the root of a fillet weld to the center of its face.

**f. Face of the Weld.** This is exposed surface of the weld, made by an arc or gas welding process on the side from which the welding was done.

**g. Toe of the Weld.** This is the junction between the face of the weld and the base metal.

**h. Reinforcement of the Weld.** This is the weld metal on the face of a groove weld in excess of the metal necessary for the specified weld size.

## **VI. NONDESTRUCTIVE TESTING (NDT):**

The NDT (nondestructive testing) methods are:

- 1. Visual Inspection - VT
- 2. Liquid Penetrant Testing - LT
- 3. Magnetic Particle Testing - MT
- 4. Radiographic Testing - RT
- 5. Ultrasonic Testing - UT
- 6. Eddy Current Testing - ET (not used in field inspection)
- 7. Acoustic Emission Testing - AET (not used in field inspection)
- 8. Phased Array Ultrasonics - PA
- 9. Time Of Flight Diffraction - TOFD

### **1. Visual Inspection - VT:**

Visual inspection after welding is very useful in evaluating quality, even if other testing methods are to be employed. As welding progresses, surface flaws such as cracks, porosity, and unfilled craters can be detected only by Visual Inspections, leading to repairs or rejection of the work.

Welds must be cleaned from slag to make inspection for surface flaws possible. A **10x magnifying glass** is helpful in detecting fine cracks and other faults. As indicated before, a **borescope and dental mirrors**, are useful for inspection inside vessels, pipe, or confined areas.



**Visual inspection** is the most popular and the most widely used of the non-destructive inspection techniques. Completed welds should be checked according to the plans and the specifications.

The most common welds that need to be inspected in the field are fillet welds. Fillet welds are designed based on their leg sizes. If the leg is under the specified dimension, then the strength required is less than what the joint was designed for. The throat of the weld should be checked also.

**Inspector visual requirements:** Performed with or without corrective lenses, to prove near vision acuity on **Jaeger J2** at not less than 12 inches and a color perception test. The objective of visual inspection at this stage is not only to detect non permissible faults, but all procedure details.

If the plans show a fillet weld at 5/16 inches then each leg of the weld needs to measure to that dimension. A **fillet weld gauge** is the standard tool to check weld sizes. The **fillet weld gauge** has two corners for checking leg sizes and two corners for checking throats of the weld. An explanation of how to use the fillet weld gauge is shown below:

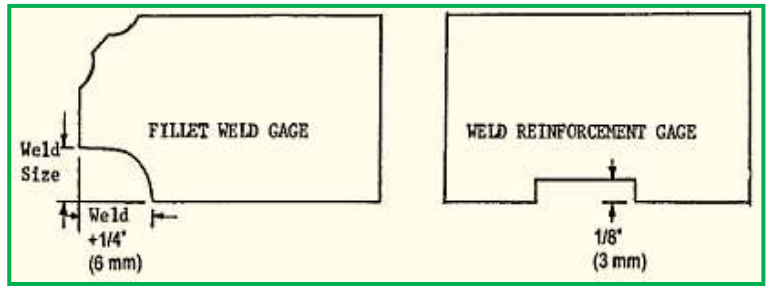
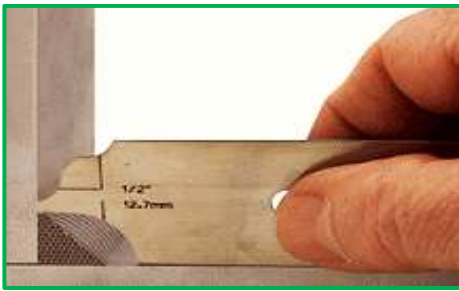

Welds should be first visually inspected. The **initial procedures** taken by the Welding Inspector are:

#### a. Details to Check Before the Welding:

1. The materials to be welded and the related standards (ASME, ASTM, etc.);
2. Welder Qualification Certificate, drawings and related documents;
3. Welder equipment and electrodes, including storage and drying systems;
4. Welding edge preparations and correct bevels;
5. Root openings;
6. Clearance of backing strip or ring;
7. Overall alignment and fit up;
8. Welding procedures during the welding.

#### b. Details to Check During the Welding:

1. Preheat and interpassing temperature;
2. Cleaning, chipping, grinding or gouging;
3. Structural defects and discontinuities;
4. Post heating temperature, when specified.

#### c. Details to Check After the Welding:

1. Dimensional accuracy of the weldment, using fillet weld gages or rulers, as shown above;
2. Conformity to drawing and procedure requirements;
3. Acceptability of welds with regard to appearance and fabrication quality;
4. The presence of any unfilled craters, undercuts, cracks, overlaps;
5. Post heating temperature, when specified.

#### d. Weld Joint Preparation:

The first step in making a sound weld is to make sure the joint is correctly cleaned using a stiff wire brush or a grinder for cleaning the base metals. The portion of the base metal to which the ground clamp will be attached must also be cleaned. Poor contact with the ground clamp will create resistance in the welding circuit and could result in poor weld quality.



Preheat prior to welding should be taken according to procedures. All unpainted surfaces have to be free from all loose or thick scale, slag, rust, moisture, grease, or other foreign material.

## 2. Liquid Penetrant Testing – LT:

Liquid Penetrant inspection methods are used to check **nonporous materials** for defects open to the surface and surface defects can be found with penetrant inspection. Several types of cracks connected with seam welding, grinding, porosity or lack of bond between metals, this method can locate.

The equipment used in Liquid Penetrant Testing is portable: aerosol cans of cleaner, dye, and a developer. When fluorescent penetrant is used, a black light source in the 36-angstrom unit range and a hood or dark area are required. Portable inspection kits for field use are commercially available.

The procedure conforms to **ASTM E 165**. There are three types of penetrant: water washable, post emulsifying, and solvent removable. Inter-mixing these materials is not permitted.

Liquid Penetrant Testing can be done quickly and easily; it costs less per foot of weld inspected than any other nondestructive method except visual inspection. However, surface porosity and improper surface cleanliness reduce the sensitivity of the inspection technique and contaminants such as water, oil, and grease can cover or fill discontinuities so the penetrant does not enter.

In Liquid Penetrant inspection, both visible and fluorescent, the surface of a **material is coated** with a film of penetrating liquid. The liquid is allowed to **seep into any flaws** that are open to the surface, and the excess surface film is removed.

A **developer** is then applied; it **draws the penetrant** from a discontinuity to the surface so the inspector can see the flaw.

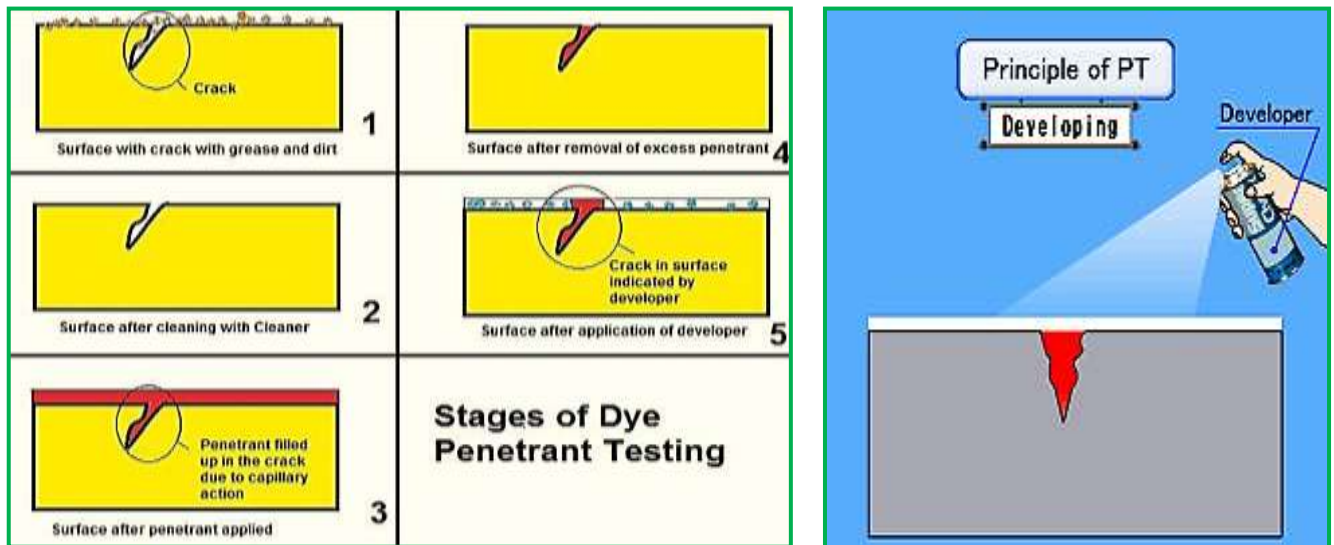

In petrochemical plants, pressure vessels and piping, which are often made of nonmagnetic materials, can be inspected for surface **shallow cracks and porosity by this method**. The indications for cracks and porosity bleed out rapidly upon application of the dry developer.

## 3. Magnetic Particle Testing – MT:

Magnetic Particle inspection is a nondestructive method of **detecting** cracks, seams, inclusions, segregations, porosity, lack of fusion, and similar flaws in **ferromagnetic** materials such as steels and some stainless steel alloys.

The main disadvantage is that it applies only to **magnetic materials** and is not suited for very small, deep-seated defects. The deeper the defect is, the larger it must be for detection. Subsurface defects are easier to find when they have a crack-like shape, such as lack of fusion in welds.

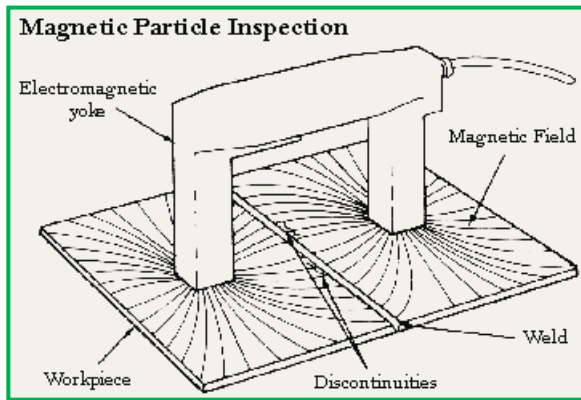

The part to be inspected is **magnetized** by passing through it a low-voltage, high-amperage electric current, or by placing it in a magnetic field. Electrical poles form at the ends of the flaws. The fine magnetic particles applied to the surface of the part are attracted to these electrical poles. The concentration of particles can be seen and the flaw located.

The magnetic particles applied to the weld can be as a **dry powder** or as a **suspension** in light oil. The particles used are **iron oxide particles** with a proper size, shape, magnetic permeability and retentivity. They can be applied by from.

**Dry particles:** Are in **powder form** and may be obtained in gray, red, or black for contrast. **Wet particles** consist of particles suspended in a light petroleum oil or kerosene. These particles are applied using aerosol cans, dipping, immersing, hand shakers, spraying and screens.

The property of any magnetic material is to keep or retain a magnetic field after the magnetizing current is removed. Usually a magnetized metal **that has high permeability** has **low retentivity**, while a metal with a low permeability has high retentivity. Construction steels generally have low retentivity. Particles **can be colored** and have a fluorescent coating for viewing with ultraviolet light.

**Wet particles:** Provide better control of magnetic particles through the concentration of suspension. The wet procedure is more sensitive for the detection of extremely small discontinuities.

The procedure conforms to **ASTM E 138, ASTM E 709, MIL-I-6868** and the ASME Boiler and Pressure Vessel Code, Section V. The surface should be cleaned of all grease, oil, loose rust or water because such materials interfere with the particles which indicate defects.

#### 4. Radiographic Testing – RT:

Radiographic inspection is a nondestructive inspection technique which involves **taking a picture** of the internal condition of a material. This picture is produced by **directing a beam of short wavelength radiation** (X-rays or gamma rays) through a material that would be opaque to ordinary light.

The radioactive isotopes most widely used are **Cobalt 60 and Iridium 192**. Gamma rays emitted from these isotopes are similar to X-rays, except the wavelengths are usually shorter. The gamma rays penetrate to greater depths than X-rays of the same power; however, exposure times are considerably longer due to the lower intensity.

This radiation **exposes a film** which is placed on the opposite side of the material. When **developed**, the film (called a radiograph), shows the presence or absence of internal defects.



Different types of internal defects and flaws can be identified such as cracks, porosity, lack of fusion and entrapped slag. Radiography uses the penetrating power of radiation to reveal the interior of a material. Radiation from a source passes through an object and causes a change in the film emulsion when the film is developed.

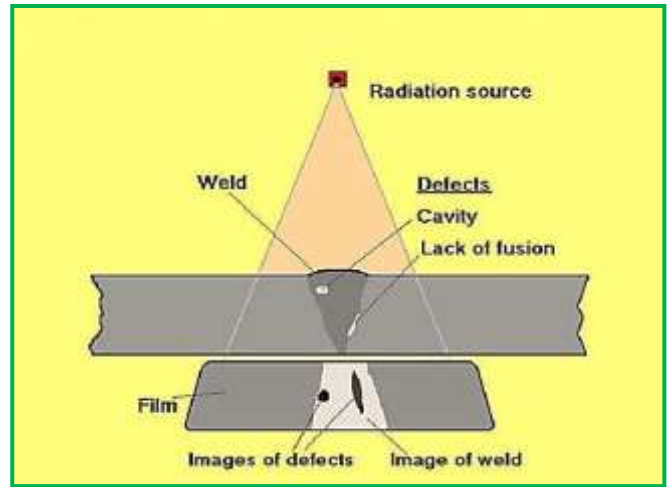
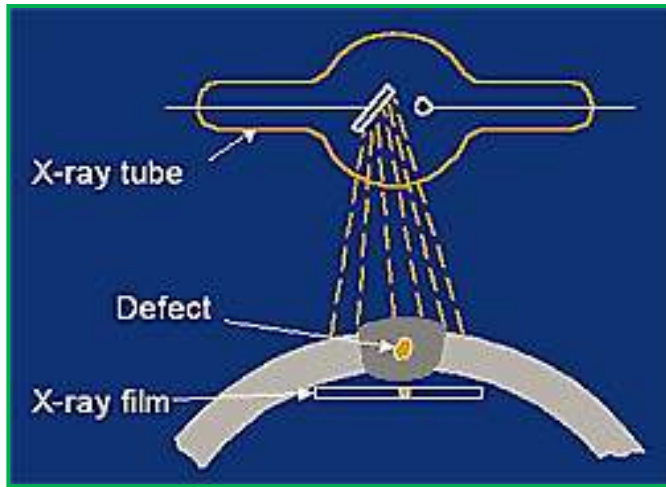

The limitations, however, include **high initial cost**, **radiation hazards**, **trained technicians** and be aware that certain defects, particularly cracks and lack of fusion, **be correctly oriented** with respect to the beam of radiation (if the orientation is incorrect, the defects will not be recorded on the film).

Not all of the **radiation penetrates the weld**. Some is absorbed, the amount depending on the density and thickness of the weld and on the material being inspected. Inadequate technique can result in poor sensitivity, irrelevant indications, or other problems.

A cavity, such as a blowhole in the weld interior, leaves less metal for the radiation to pass through, so that the amount absorbed by the weld will vary in the defective region. These variations recorded on a radiation-sensitive film, produce an image that will indicate the presence of the defect.

The procedure conforms to **ASTM E 94**, **ASTM E 142**, and AWS D1.1. Procedures are also outlined in MIL-R-11470, MIL-STD-453, and the ASME Boiler and Pressure Vessel Code, Section V.

## 5. Ultrasonic Testing – UT:

Ultrasonic inspection is an energy wave form with frequencies above **20,000 Hertz**. The **ultrasonic wave is introduced** into the material **by a piezoelectric transducer** placed in contact with the test specimen. The ultrasound enters the specimen and is **reflected back to the transducer** when it encounters an **interface that could be a flaw** or the back surface of the material.

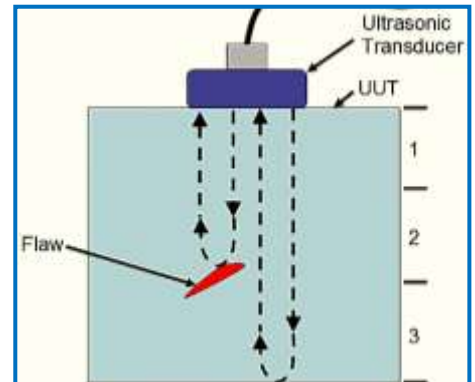

The transducers consist of a **straight beam and an angle beam** in the frequency range of 0.1 to 15.0 MHz. The angle beam transducers that can be used are of 70°, 60° and 45°.

The ultrasonic vibrations are converted to electric signals, amplified, and **displayed on a Cathode Ray Tube (CRT)** screen. Because of the high frequency (above the range for the human ear), the short wave-length **allows small flaws** to be detected.

Ultrasonic reference blocks are usually needed to check the sensitivity and performance of ultrasonic instrumentation and transducers for inspecting critical welds. AWS D1.1 recommends several standards, the most common being the International Institute of Welding (IIW) reference blocks.

By using **calibrated standards blocks** and a few calculations, the inspector can classify the indications as irrelevant, acceptable, or unacceptable. Ultrasonic inspection has a higher sensitivity level than radiographic inspection.

Ultrasonic inspection detects both **internal and surface flaws** in all types of welded joints. Defects such as slag inclusions, porosity, lack of fusion, lack of penetration (root defects), longitudinal and transverse cracks can be detected.

Indications of defects **can be seen immediately on the CRT**. Both internal and surface flaws can be detected, though shallow surface cracks are more easily and reliably detected with Magnetic Particle or Liquid Penetrant.

The limitations to restrict its use are the difficulty in interpreting the oscilloscope patterns and the need for standards to calibrate the instrument. A high degree of operator skill and training is required to interpret the oscilloscope patterns reliably.

The procedure conforms to **ASTM E 164** and AWS D1.1. The procedures are also outlined in Appendix U to the ASME Boiler and Pressure Vessel Code, Section VIII, Division 1, and in Section V, Article 5.

## 6. Eddy Current Testing – ET:

Eddy-current inspection uses **electromagnetic induction** to detect flaws in **conductive** materials. A circular coil carrying current is placed in proximity to the test specimen (electrically conductive). The alternating current in the coil generates changing magnetic field which interacts with test specimen and generates eddy current.

The **term eddy current** (also called Foucault currents) comes from analogous currents seen in **water** where localized areas of turbulence **known as eddies** give rise to persistent vortices. When alternating current is applied to the conductor, such as copper wire, a magnetic field develops in and around the conductor.

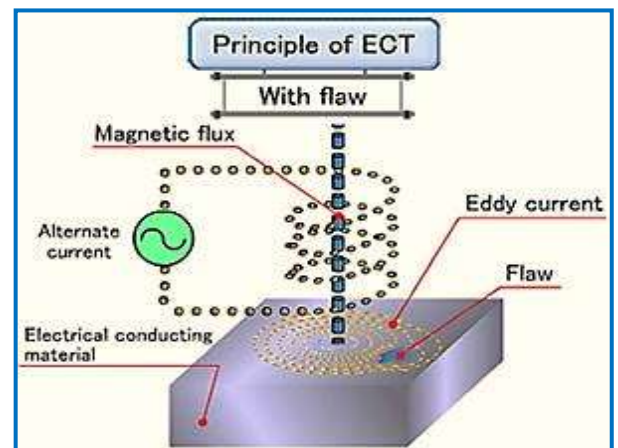
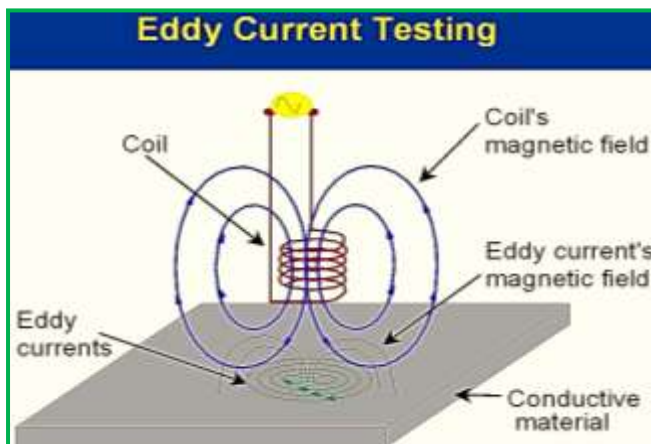

Variations in the electrical conductivity or magnetic permeability of the test object, or the presence of any flaws, will cause a change in eddy current and a corresponding change in the phase and amplitude of the measured current. This is the basis of standard (flat coil) eddy current inspection.

There are several limitations, among them: **only conductive materials** can be tested, the surface of the material must be accessible, the finish of the material may cause bad readings, the depth of penetration into the material is limited, and flaws that lie parallel to the probe may be undetectable.

## 7. Acoustic Emission Testing – AET:

Acoustic Emission Testing (AET) unlike most other nondestructive testing (NDT) **is not used commonly**. AET simply listens for the energy released by the object or basically **detect acoustic waves** generated by sudden movement in solid materials. However, can also detect sources as small as from a pinhole leak or as large as brittle crack advance.

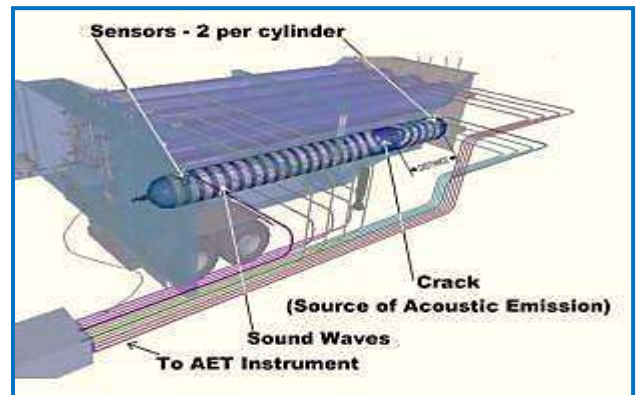
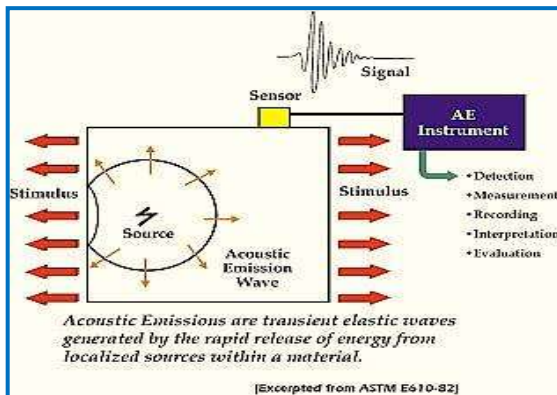

AE tests are often **performed on structures while in operation**, as this provides adequate loading for propagating defects and triggering acoustic emissions.

## 8. Phased Array Ultrasonics - PA:

Phased Array Ultrasonics is an advanced **method of ultrasonic testing** that has applications in **medical imaging** and **nondestructive testing**. Common applications are to examine the **heart** non-invasively or to **find flaws** in **manufactured** materials such as welds.

Single-element (non-phased array) probes—known technically as monolithic probes, emit a beam in a fixed direction. To test or interrogate a large volume of material, a conventional probe must generally be physically turned or moved to sweep the beam through the area of interest.

No.	Methods	Features
1	Normal beam method Normal longitudinal transducer Mechanical scan	-Scanning: Mechanical -1D (normal)
2	Phased array method (Sector scanning) Array transducer Mechanical rotation	-Scanning: Electrical and mechanical rotation -2D (sector)
3	Three dimensional (3-D) ultrasonic phased array method Matrix array transducer Electrical scan (rotation)	-Scanning: Electrical -3D (sector and rotation)



**Examination by phased array:** On the top, probe emits a series of beams to flood the weld with sound. Bottom, the flaw in the weld appears as a red indication on the instrument screen.

The beam is controllable because a phased array probe is made up of multiple small elements, each of which can be pulsed individually at a computer-calculated timing. The term **phased** refers to the **timing**, and the term **array** refers to the **multiple** elements.

### 9. Time Of Flight Diffraction (TOFD):

TOFD was originally intended for sizing of welding flaws which have been detected with other ultrasonic methods. This technique was used in Germany and later it was published that the TOFD technique had also been used for a variety of flaw detections. In addition, the simplicity of its **scanning concept** enables application on many different components, including such complex geometries as nozzles and nodes.

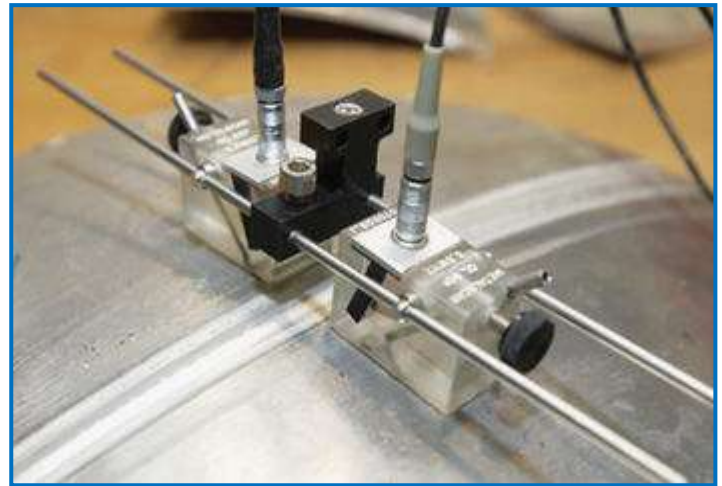
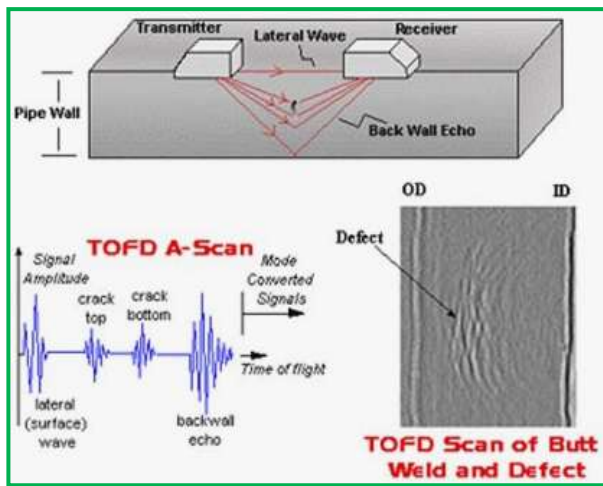

### 10. NDT Method Summary:

No single NDT method will work for all flaw detection or measurement applications. Each of the methods has **advantages and disadvantages** when compared to other methods. The table below summarizes the scientific principles for some of the most often used NDT methods.

The NDT strengths and weaknesses tend to complement each other. While radiography is unable to reliably detect lamination-like defects, ultrasound is much better at it. On the other hand, ultrasound is poorly suited to detecting scattered porosity, while radiography is very good.

Penetrant Testing	Magnetic Particle Testing	Ultrasonic Testing	Eddy Current Testing	Radiographic Testing

<p>Penetrant solution is applied to the surface of a pre-cleaned component. The liquid is pulled into surface-breaking defects by capillary action. Excess penetrant material is carefully cleaned from the surface. A developer is applied to pull the trapped penetrant back to the surface where it is spread out and forms an indication. The indication is much easier to see than the actual defect.</p>	<p>A magnetic field is established in a component made from ferromagnetic material. The magnetic lines of force travel through the material, and exit and reenter the material at the poles. Defects such as crack or voids cannot support as much flux, and force some of the flux outside of the part. Magnetic particles distributed over the component will be attracted to areas of flux leakage and produce a visible indication.</p>	<p>High frequency sound waves are sent into a material by use of a transducer. The sound waves travel through the material and are received by the same transducer or a second transducer. The amount of energy transmitted or received and the time the energy is received are analyzed to determine the presence of flaws. Changes in material thickness, and changes in material properties can also be measured.</p>	<p>Alternating electrical current is passed through a coil producing a magnetic field. When the coil is placed near a conductive material, the changing magnetic field induces current flow in the material. These currents travel in closed loops and are called eddy currents. Eddy currents produce their own magnetic field that can be measured and used to find flaws and characterize conductivity, permeability, and dimensional features.</p>	<p>X-rays are used to produce images of objects using film or other detector that is sensitive to radiation. The test object is placed between the radiation source and detector. The thickness and the density of the material that X-rays must penetrate affect the amount of radiation reaching the detector. This variation in radiation produces an image on the detector that often shows internal features of the test object.</p>
--	---	--	--	---

### Main Uses

<p>Used to locate cracks, porosity, and other defects that break the surface of a material and have enough volume to trap and hold the penetrant material. Liquid penetrant testing is used to inspect large areas very efficiently and will work on most nonporous materials.</p>	<p>Used to inspect ferromagnetic materials (those that can be magnetized) for defects that result in a transition in the magnetic permeability of a material. Magnetic particle inspection can detect surface and near surface defects.</p>	<p>Used to locate surface and subsurface defects in many materials including metals, plastics, and wood. Ultrasonic inspection is also used to measure the thickness of materials and otherwise characterize properties of material based on sound velocity and attenuation measurements.</p>	<p>Used to detect surface and near-surface flaws in conductive materials, such as the metals. Eddy current inspection is also used to sort materials based on electrical conductivity and magnetic permeability, and measures the thickness of thin sheets of metal and nonconductive coatings such as paint.</p>	<p>Used to inspect almost any material for surface and subsurface defects. X-rays can also be used to locate and measure internal features, confirm the location of hidden parts in an assembly, and to measure thickness of materials.</p>
--	---	---	---	---

### Main Advantages

<p>Large surface areas or large volumes of parts/materials can be inspected rapidly and at low cost. Parts with complex geometry are routinely inspected. Indications are produced directly on surface of the part providing a visual image of the discontinuity. Equipment investment is minimal.</p>	<p>Large surface areas of complex parts can be inspected rapidly. Can detect surface and subsurface flaws. Surface preparation is less critical than it is in penetrant inspection. Magnetic particle indications are produced directly on the surface of the part and form an image of the discontinuity. Equipment costs are relatively low.</p>	<p>Depth of penetration for flaw detection or measurement is superior to other methods. Only single sided access is required. Provides distance information. Minimum part preparation is required. Method can be used for much more than just flaw detection.</p>	<p>Detects surface and near surface defects. Test probe does not need to contact the part. Method can be used for more than flaw detection. Minimum part preparation is required.</p>	<p>Can be used to inspect virtually all materials. Detects surface and subsurface defects. Ability to inspect complex shapes and multi-layered structures without disassembly. Minimum part preparation is required.</p>
--	--	---	---	--

### Main Disadvantages

<p>Detects only surface breaking defects. Surface preparation is critical as contaminants can mask defects. Requires a relatively smooth and nonporous surface. Post cleaning is necessary to remove chemicals. Requires multiple operations under controlled conditions. Chemical handling precautions are necessary (toxicity, fire, waste).</p>	<p>Only ferromagnetic materials can be inspected. Proper alignment of magnetic field and defect is critical. Large currents are needed for very large parts. Requires relatively smooth surface. Paint or other nonmagnetic coverings adversely affect sensitivity. Demagnetization and post cleaning is usually necessary.</p>	<p>Surface must be accessible to probe and couplant. Skill and training required is more extensive than other technique. Surface finish and roughness can interfere with inspection. Thin parts may be difficult to inspect. Linear defects oriented parallel to the sound beam can go undetected. Reference standards are often needed.</p>	<p>Only conductive materials can be inspected. Ferromagnetic materials require special treatment to address magnetic permeability. Depth of penetration is limited. Flaws that lie parallel to the inspection probe coil winding direction can go undetected. Skill and training required is more extensive than other techniques. Surface finish and roughness may interfere. Reference standards are needed for setup.</p>	<p>Extensive operator training and skill required. Access to both sides of the structure is usually required. Orientation of the radiation beam to non-volumetric defects is critical. Field inspection of thick section can be time consuming. Relatively expensive equipment investment is required. Possible radiation hazard for personnel.</p>
--	---	--	--	---

### 11. Choices Control Quality:

A good **NDT inspection program** must recognize the inherent limitations of each process. Whatever inspection techniques are used, paying attention to the **"Five P's" of weld quality** will help reduce subsequent inspection to a routine checking activity as shown below:

**The Five P's:**

**Process Selection.** The process must be right for the job.

**Preparation.** The joint configuration must be right and compatible with the welding process.

**Procedures.** The procedures must be spelled out in detail and followed religiously during welding.









**Pretesting.** Full-scale mockups or simulated specimens should be used to prove that the process and procedures give the desired standard of quality.

**Personnel.** Qualified people must be assigned to the job.

### 12. NDT Method Selection:

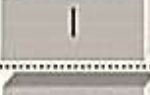
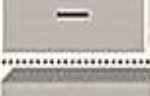
Since each NDT method has its own set of advantages and disadvantages and some are better suited than others for a particular application, the NDT technician or engineer **must select the method** that will detect the defect or make the measurement with the **highest sensitivity and reliability**. The cost effectiveness of the technique must also be taken into consideration.

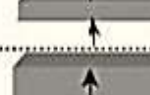
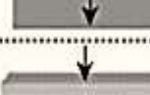
The following table provides some **guidance** in the selection of NDT methods for common flaw detection and measurement applications.

Flaw Type	Inspection Method	Visual	Liquid Penetrant	Magnetic Particle (A)	Ultrasonic		Eddy Current (B)	X-Ray
					Straight Beam	Angle Beam		
Surface Breaking Linear		1	3	3	1	2	3	1
Surface Breaking Volumetric Defect		3	3	3	3	3	3	3
Near-Surface Linear & Normal to Surface		0	0	2	1	2	3	1
Near-Surface, Linear & Parallel to Surface		0	0	0	3	3	0	0
Near-Surface, Volumetric		0	0	2	3	3	3	3
Subsurface, Linear & Normal to Surface		0	0	0	1	2	0	1
Subsurface, Linear & Parallel to Surface		0	0	0	3	3	0	1
Subsurface, Volumetric		0	0	0	3	3	0	3
Thickness Measurement of Thin Materials		0	0	0	3	3	3	3
Thickness Measurement of Thick Materials		0	0	0	3	3	0	3
Non-Conductive Coating Thickness Measurements		0	0	0	2	2	3	1

\* "Surface" refers to the surface most suitable for the inspection given the various options

(A) Ferromagnetic materials only

(B) Conductive materials only

(0) Will not detect

(1) Not well suited

(2) Fairly well suited

(3) Ideal Application

## VIII. DESTRUCTIVE TESTING:

In procedure qualification testing and welding development work, metallographic specimens are sometimes removed from a structure to check the quality of the weldment. These tests are used to determine visually the characteristics of the welds. Metallographic test samples are sections cut through the welds in any desired plane, then polished and etched to reveal the structure.

These specimens may be examined with the naked eye or with various magnifications, including microscopic. The characteristics to be checked are the **soundness, location, and depth of penetration** of the welds; the metallurgical structures of the **weld, fusion zone, and heat affected zone**; the **extent and distribution of undesirable inclusions** in the weld; **hardness gradients**; and the **number of weld passes**.

When metallographic specimens are removed from any part of a structure, repairs must be made by qualified welders or welding operators using accepted welding procedures. Peening or heat treatment may be required to develop the full strength of the members cut and to relieve residual stress.

## 1. Test methods:

There are three categories of destructive tests: Chemical, hardness, and mechanical tests.

**1.1. Chemical tests.** Chemical tests are generally used to validate the chemical composition or the corrosion resistance of the base and weld metals. Particular compositions of the metals involved, for example, may be examined for conformance to specifications. In addition, chemical analysis of the weld metal can show whether welding produced the expected results, or whether it introduced undesirable constituents into the weld metal.

Corrosion tests demonstrate a weldments capability to withstand the corrosive environment to be encountered in service. Because of the cost and time involved, a weldment usually cannot be tested for corrosion resistance by actual use under service conditions. Therefore, accelerated corrosion tests that can be conducted under laboratory conditions have been developed.

**1.2. Hardness tests.** Hardness tests measure the resistance of materials to wear. For most metals, ductility and corrosion resistance decrease as the hardness increases. Since each operation during welding has metallurgical effects, some specifications call for an upper limit to the acceptable hardness of various areas of weld.

Hardness testing is done with equipment which, under a specific load, forces a small hardened steel ball or diamond point into the surface of the metal. The depth of penetration is either measured directly by the machine, or inferred from the dimensions of the impression. Associating a number with each possible impression depth, the inspector can develop a hardness scale.

This testing approach is used by the three most common hardness measuring devices: the Brinell, Rockwell, and Vickers hardness testers. Hardness numbers may vary from method to method because of differences in the formulas used to define hardness numbers, in the material type and shape used to make the impression, and in the imposed load.

**1.3. Mechanical tests.** Mechanical tests (exclusive of hardness) have been designed to test several weld properties.

### a. Tensile Test:

- Tensile tests are conducted on specimens machined from a test weld and are used to measure the strength of the weld joint. Specimens are usually taken perpendicular to the weld, which is centered in the specimen.

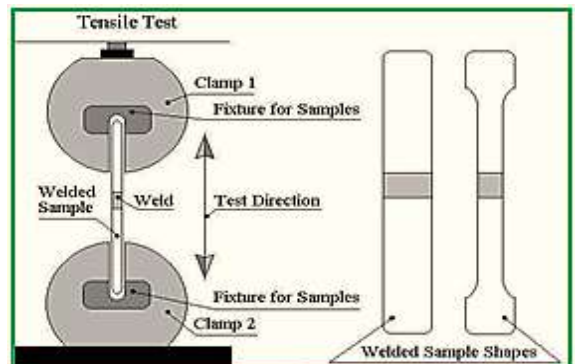
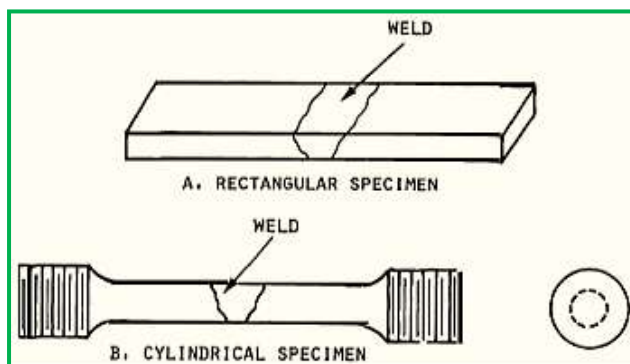



- Specimens are sometimes taken along the weld and consist entirely of weld metal. Specimens may have round or rectangular cross sections, depending on the requirements of the applicable welding code. The testing machine applies a tensile force until **ruptures**.
- From readings on the machine and measurements of the specimen before and after the test, properties such as yield point or yield strength, ultimate strength, and ductility are calculated.
- Guided **bend tests** indicate a weld's **ductility**. Test specimens are described as root-bend, face-bend, or side-bend, depending on the surface stretched in bending. Rectangular specimens for tensile tests are machined or ground to remove any weld reinforcement.

## b. Impact Toughness:

The impact toughness of a material can be determined with a **Charpy or Izod test**. These tests are named after **their inventors** and were developed in the early **1900's** before fracture mechanics theory was available.

Impact properties are not directly used in fracture mechanics calculations, but the economic impact tests continue to be used as a quality control method to assess notch sensitivity and for comparing the relative **toughness of engineering materials**. The two tests **use different specimens** and methods of holding the specimens, but both tests make use of a pendulum-testing machine.

For **both tests**, the **specimen is broken** by a single overload event due to the **impact** of the **pendulum**. A stop pointer is used to record how far the pendulum swings back up **after fracturing** the specimen.

The impact toughness of a metal is determined by **measuring the energy absorbed** in the fracture of the specimen. This is simply obtained by noting the height at which the pendulum is released and the height to which the pendulum swings after it has struck the specimen .

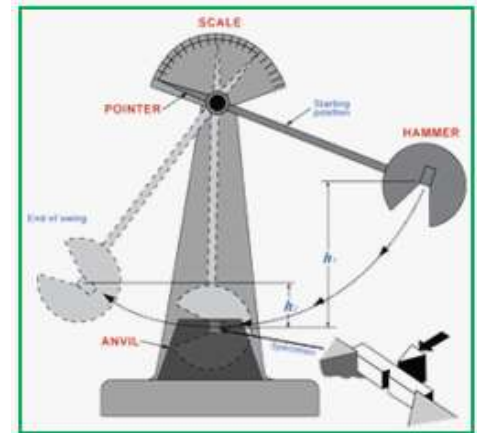

The **height of the pendulum times the weight** of the pendulum produces the potential energy and the difference in potential energy of the pendulum at the start and the end of the test is **equal to the absorbed energy**.

## c. Charpy V-Notch Toughness:

Notch toughness is the capacity that a material possesses to **absorb energy** in the **presence of a flaw**, such as a notch or crack. The material will likely exhibit a lower level of toughness. When a flaw is present in a material, loading induces a triaxial tension stress state adjacent to the flaw. The material **develops plastic strains** as the yield stress is exceeded, near the crack tip.

Notch-toughness is **measured with a variety of specimens** such as the **Charpy V-notch impact specimen** or the dynamic tear test specimen. As with regular impact testing the tests are often repeated numerous times with specimens tested at a different temperature.

With these specimens and by varying the loading speed and the temperature, it is possible to **generate curves such as those shown** in the graph. Typically only static and impact testing is conducted but it should be recognized that many components in service see intermediate loading rates in the range of the dashed red line.

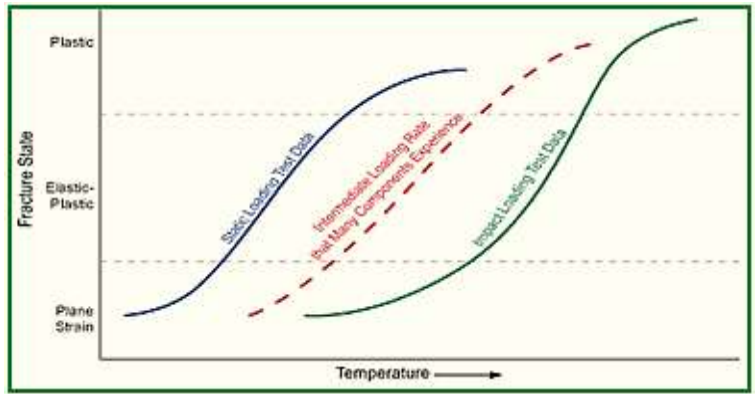
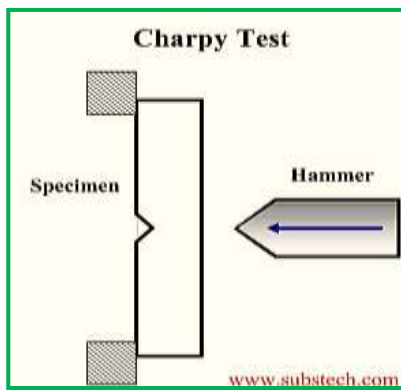

#### d. Bend Test:

Free bend tests **for ductility**, use specimens similar to those for guided bend tests. Before the test, gage lines are inscribed across the width of the sample of deposited weld metal. A testing device is used to make the bend with the plunger removed, the specimen is placed across the shoulders of the jig with the weld centered.

The plunger is then forced down until the specimen is bent into a U shape. The specimen **fails if it has cracks** or other open defects greater than a specified number and size, or if it fractures.

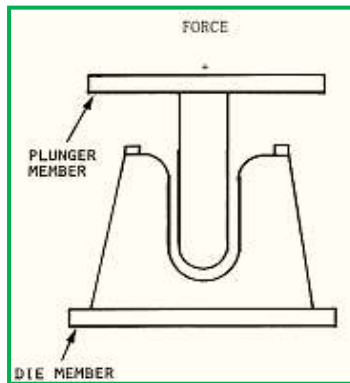

These lines mark off a distance about 1/8 inch less than the width of the weld. The sample is given an initial bend by supporting the ends or shoulders on rollers, then forcing the center down until the specimen takes a permanent set.

#### e. Compress Test:

A testing machine or device is used to compress the sample longitudinally until a **crack or depression** appears on the convex face of the specimen, or until the specimen is bent double.

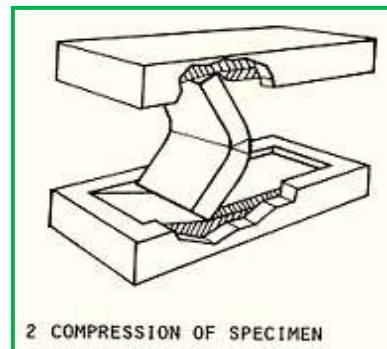
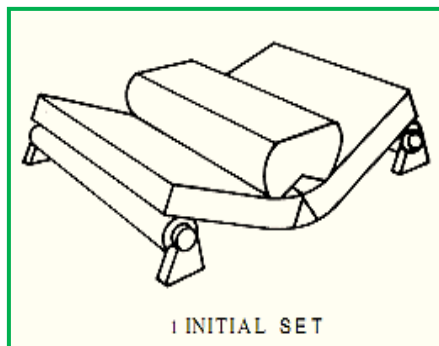

The load is removed immediately if a defect appears before the specimen is bent double. Percent elongation is calculated from the initial and final distances between the gage marks.

## f. Shear Test:

Shear tests of fillet welds are conducted by pulling specimens apart in a testing machine. Various types of impact tests are sometimes used to test the fracture toughness of the weld metal when low-alloy, high-strength steels are being welded. These tests measure the weld metal's capability to resist crack propagation under low stress.

## 2. Test Methods for Welds:

Some weldments may **require combinations** of two or more inspection methods to provide adequate evaluation. Destructive testing is used primarily for the qualification of welding procedures, welders, welding operators, and sometimes for quality control.

Tests for Welds	
Defect	Methods of Testing
DIMENSIONAL DEFECTS	
Warpage	Visual inspection with proper mechanical gauges
Incorrect joint preparation	Visual inspection - Comparison with workmanship sample
Incorrect weld size	Visual inspection with proper mechanical gauges
Incorrect weld profile	Visual inspection with proper mechanical gauges
Incorrect final dimensions	Visual inspection with proper mechanical gauges
STRUCTURAL DISCONTINUITIES	
Porosity	Radiographic - Magnetic Particle - Ultrasonic
Slag Inclusions	Radiographic - Magnetic Particle - Ultrasonic
Incomplete fusion	Radiographic - Magnetic Particle - Ultrasonic
Inadequate joint penetration	Radiographic - Magnetic Particle - Ultrasonic
Undercut	Visual inspection
Cracks	Visual inspection - Radiographic - Magnetic particle
Surface	Visual inspection - Comparison with workmanship sample

## IX. WELDING ELECTRODES AND PREHEAT REQUIREMENTS:

The procedure requirements for welding electrodes and preheating temperatures are as follows:

1. Welding must be done with the same process (SMAW or FCAW) used for qualification.
2. If the operator has qualified on any of the steel permitted (ASTM A36 and A588), that same operator is qualified to weld on the other and on SAE 1010 or ASTM A252.

**3.** A welder qualified for manual shielded metal-arc welding with E7018 electrodes may also weld with **E7016 electrodes**. Identifying electrode numbers are as follows:

- The **70 designation** shall be understood to mean the **70 series** unless an alloy steel of higher strength is to be welded.
- The third digit indicates the position permitted. If the **digit is "1,"** the electrode may be used for welding in any position. If "2," only the down hand position may be used.
- The **fourth digit** indicates the chemical make-up of the electrode coating. The **digit 6** indicates **low hydrogen potassium**, and **8 a low hydrogen iron powder**.
- Preheating of the base metal means that the surfaces of the parts being welded, within **3 inches** laterally and in advance of the welding, must be at or above the following prescribed temperature:

### 1. Preheating:

**Preheating** is the required practice of providing localized heat to the weld zone. **Minimum preheat** required is listed below:

Minimum Preheat Temperature (degrees F)				
<u>Base Metal</u>	<u>Thickness of Thickest Part at Point of Welding</u>			
	<u>To 3/4"</u> <u>Incl.</u>	<u>Over 3/4"</u> <u>to 1-1/2"</u>	<u>Over 1-1/2"</u> <u>to 2-1/2"</u>	<u>Over 2-1/2"</u> <u>Incl.</u>
A36, A572, A588 (A709-Grade 36, 50, 50W)	50	70	150	225

For ASTM A36, **up to and including 3/4 inch** thickness – with low hydrogen electrodes, the preheat temperature requirement is **50°F (10°C)**. For thicknesses **over 3/4 inch** the preheat temperature requirement is **70°F (21°C)**.

For ASTM 1010, preheat requirement **is the same as in item 1**. For ASTM A252, the preheat temperature is **225°F (107°C)** when welding with low hydrogen electrodes. Welding when the ambient temperature is below 0°F (-18°C) is not permitted.

All electrodes having low hydrogen coverings shall be purchase in hermetically sealed containers or shall be **dried** for at least **two hours** between **450°F and 500°F (232°C and 260°C)** before used.

Immediately after drying or removal from hermetically sealed containers, electrodes shall be kept in storage **ovens** of at least **250°F (121°C)**. Electrodes **not used within four hours** after removal from the drying or storage oven must be **re-dried** before use.

For the ordinary field pile welding job, electrodes should be purchased in small packages, allowing for use within the prescribed time limit, unless provision for storage at **250°F (121°C)** is made.

E7016 and E7018 electrodes for field welding must be preferred. The **digit 1** permits welding in **all positions**. These electrode coatings are **low in hydrogen**, permitting use on A36 and SAE 1010 steels **without preheating** the base metal, unless the temperature is below **50°F (10°C)**. These electrodes are also required for making the **prequalification test**.

The **restrictions and rules for preheating** as outlined above cover the welding of all of our steel piling, since they apply to steel **up to 3/4 inch thick**. If welding is required on **thicker plates**, other special rules apply.

Electrodes that are allowed for **Flux Cored Arc Welding** are E60T-1, E60T-5, E60T-6, E60T8, E70T-1, E70T-5, E70T-6 or E70T-8. When welding ASTM A588 steel, only the E70 series may be used.

## 2. Preheating Evaluation:

The preferred method of preheating is by the **use of a manual torch**. Required preheat shall be applied for a distance of 3 inches in all directions from the weld joint. When the temperature falls below **32 °F** the base metal shall be heated to at least **70 °F**.

Welding should **not be done** when the ambient temperature around the weld joint is below **0 °F**. Preheat can be **checked** by the use of a **Tempstick**. If the weld joint has reached the required level of preheat the appropriate Tempstick will **melt when rubbed** across the base metal.



**Fahrenheit Temperature Sticks** are available as follows:

6° increments	100°-350°	50° increments	650°-900°
2°-13° increments	350°-500°	Approx. 25° increments	900°-1050°
5° increments	500°-650°	50° increments	1050°-2500°

### Permissible Length of Welding Leads:

Wire	Size	Diameter of Each Wire – Mils	No. of Strands	Maximum (permissible) Length of cable -feet
1/0	0	74.5	19	100 ft. (30.48 m)
2/0	00	83.7	19	150 ft. (45.72 m)
3/0	000	94.0	19	225 ft. (68.58 m)
4/0	0000	105.5	19	300 ft. (91.44 m)

### Typical Current Ranges for Electrodes in Amperes:

3/32 in. (2.38 mm)	65-110	70-100	-
1/8 in. (3.18 mm)	100-150	115-165	140-190
5/32 in. (3.97 mm)	140-200	150-220	180-250
3/16 in. (4.76 mm)	180-255	200-275	230-305
7/32 in. (5.58 mm)	240-320	260-340	275-365
1/4 in. (6.35 mm)	300-390	315-400	335-430
5/16 in. (7.94 mm)	375-475	375-470	-

## X. CLASSIFICATION OF ELECTRODES:

Classification consists of a prefix letter "E" specifying an electrode, a group of two or three digits specifying weld metal strength in ksi in the 'as-weld' or stress relieved condition, and a final two digits specifying type of covering, weld position and current characteristics.

### 1. Nomenclature of electrode specification:

E60xx - 60ksi (420MPa)

E70xx - 70ksi (490 MPa)

E80xx - 80ksi (560 MPa)

E90xx - 90ksi (630 MPa)

E100xx - 100 ksi (700 MPa)

Exx10 - Cellulosic covering for the use with DC reversed polarity

(E6010) - Deep penetration and all positions electrode for general purpose.

Exx11 - Cellulosic covering for AC or DC., all position.

(E6011) - Deep Penetration and thin slag, X-ray quality weld.

Exx12 - Rutile covering AC or DC, all positions.

(E6012) - Medium penetration, good choice for fit-up work.

Exx13 - Rutile electrode, AC or DC, all position.

(E6013) - Good performance in sheet metal welding.

Exx14 - Iron powder rutile same characteristic as Exx 13, but with a higher welding speed.

Exx15 - Basic low hydrogen covering requiring use of DC only, all positions for steel welds.

(E7015) - Good for high sulfur steels.

Exx16 - Basic low hydrogen covering as Exx15 but with addition of potassium

(E7016) - Salts to allow operation with AC.

Exx18 - Low hydrogen electrode as Exx 16, but with 30% iron powder to give (E7018)

Exx20 - Typical mineral (iron oxide/silicate) covering for use in flat and (E6020)

Exx24 - Rutile and 50 per cent iron powder covering similar to Exx12, with (E7024)

Exx27 - Mineral plus 50 iron powder covering with similar (E6027) characteristics to Exx20.

Exx28 - Low hydrogen basic plus 50 per cent iron powder covering with high (E7028) deposition rate

Exx30 - Mineral covering similar to Exx20 but high deposition rates. F position only.

**Note :** Typical **electrodes in brackets** are most widely used. The use of mineral or iron oxide/silicate covered electrodes is decreasing in the USA and UK.

### 2. Electrodes Designations:

**Electrode types:** EX XXXX such as, ER 4211:

The **first letter "E"** indicates a covered electrode for **SMAW**, manufactured by extrusion process. The **second letter "R"** indicates type of covering e.g., **R** = Rutile, **A** = Acid, **B** = Basic, **C** = Cellulosic, **RR** = Rutile heavy coated, **S** = any other type not mentioned here.

The **first numerical "4"** indicates strength (UTS = 410-510 MPa) in combination with the yield strength of the weld metal deposit YS = 330 MPa. The **second numerical** digit indicates percent elongation in combination with the impact value of the weld metal deposited. Thus **"2"** means 22 per cent minimum elongation with impact 47 J at zero °C.

The **third digit "1"** shows welding position in which the electrode may be used.

1 = means all positions.

2 = all position except vertical

3 = flat butt weld horizontal/vertical fillet weld

4 = flat butt and fillet weld

5 = vertical down and flat butt

6 = any position not mentioned here.

## XI. WELDING FAILURES:

Failure investigation often **uncovers facts** that lead to changes in design, manufacturing, or operating practice, which will eliminate similar failures in the future. Failures of insignificant parts can also lead to advances in knowledge and should be done objectively, as with a large structure.

The following four areas of interest should be investigated to determine the cause of weld failure and the interplay of factors involved:

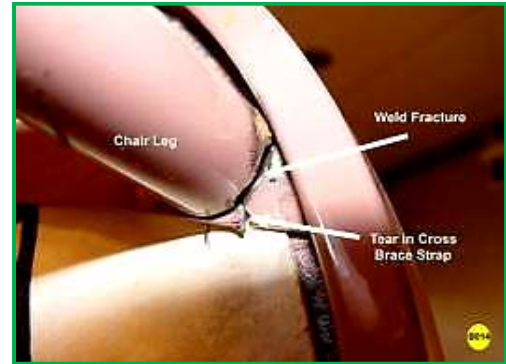

**1) Initial observation.** The detailed study by visual inspection should be made at the failure site as quickly as possible. Photographs should be taken, preferably in color, of all parts, structures, failure surfaces, fracture texture appearance, final location of component debris, and all other factors.

**2) Background data.** All information concerning specifications, drawings, component design, fabrication methods, welding procedures, weld schedules, repairs in and during manufacturing and in service, maintenance, and service use. Attention should be given to environmental details, including operating temperatures, normal service loads, overloads and cyclic loading.

**3) Laboratory studies.** Studies should also be made microscopically in those situations in which it would lead to additional information. Fracture surfaces can be extremely important. Any other defects in the structure that are apparent, even though they might not have contributed to the failure, should also be noted and investigated.

**4) Failure assumptions.** It is important to know what specific things did not happen or what evidence did not appear to help determine what happened. The data should be tabulated and the actual failure should be synthesized to include all available evidence.



**Obs.:** Failure cause can usually be classified in one of the following three classifications:

- (1) Failure due to faulty design or misapplication of material.
- (2) Failure due to improper processing or improper workmanship.
- (3) Failure due to deterioration during service.

## XII. WELDING TEST COUPON PROCEDURES:

Follow a clear example of test coupons procedures for a **3G welding certification**. In this 3G welding procedure the notes were taken from the **same section of the AWS code** that are used for the **3/8 inch** limited thickness test procedure.



The **test coupons** shall be **pre-cut** and ready to prepare. The welder shall grind the face of the test plates a minimum of one inch back from the bevel and a minimum of a quarter of an inch.

Next the backing bar to bare metal shall be cleaned with a grinder and cleaned the oxidation off of the bevel, to bare metal. After the Welding Inspector will check the bevel angles with a protractor.

### 1. The Root Pass:

The welder shall set to **root opening with two 1/8 inch** welding electrodes and then the test plate shall be inspected for fit-up. The test coupon shall be put in a **vertical position** and marked with a **white marker** to make sure not move the plate anytime during welding or cleaning. This is done because the AWS procedure notes state:

*"Now the test will be placed in the **fixed position**. The test piece will be marked in position with a marker and the **Inspector may see** the test anytime during the testing. During the test, the pieces **shall not be moved** in any direction and or removed from the testing place without the Inspectors approval".*



After the root, the welding procedure states:

*"The **root of the weld shall be inspected**, and there shall be no evidence of cracks, incomplete fusion, or inadequate joint penetration.*

*A concave root surface is permitted within the limits shown below, providing the total weld thickness is equal to or greater than that of the base metal.*



The **maximum root surface** concavity shall be  $1/16$  in. (1.6 mm) and a maximum melt-through shall be  $1/8$  in. (3 mm)"

## 2. The Hot Pass:

The hot pass shall be done using the **same technique** as the **root pass**. A single pass shall be filled with no restarts. The slag shall be cleaned.



## 3. The Cap Weld:

The plate shall be **let to cool down** till the welder could almost touch it. The cap of the weld shall be done using the **weave technique**, while **washing** the weld about  $1/16$  of an inch past the edge of the bevel.

The sides must be held for about a second before moving back to the other side. The cap shall be also done in a single pass just like the root and hot pass. The welder must give good weld penetration, preventing face bend failure and undercut.

The acceptance criteria for the face of the weld are as follows, according to AWS:

*"The face of the weld shall be **flush with the surface** of the base metal, and the weld shall merge smoothly with the base metal. Undercut shall not exceed  $1/32$  in. (1 mm). Weld reinforcement shall not exceed  $1/8$  in. (3 mm)"*

The **first picture** below is the weld still covered in slag. The **second picture** is the slag lifting itself off of the cap. The **last picture** is the cap cleaned with a wire brush.



## 4. Bend Test Coupon Preparation:

First the centerline on the plate shall be marked. Then another line **1.0 inch** above the center line and another line 1 inch below the center line.

This is the section that can be used as an **alternate coupon** in the event of **corner cracks** with no evidence of slag inclusions.

Next, marking of the actual **root** and face bend specimens. Using the top and bottom line, another line a minimum of **1½ inches above**.

The top line shall be marked and then **1½ inches below** the bottom line. The **minimum width** of a test specimen needs to be **1½ inches** wide.

After that the **Welding Inspector shall mark the test coupons** for a root and face bend in agreement with the welder, cutting them on a band saw.

### 5. Backing Bar Removal:

The **backing bar** removal can be done using a vice and using a grinder on the center of the backing bar to gouge it, about **1/16"** or so, to take the backing bar away from the back of the test plate.

The welder shall **repeat this action** until all of the backing bars are removed on the test coupons. The pictures below give a good illustration of how to remove a backing bar.



After the **backing bar is removed**, the face and the root of the weld shall be ground flush to the base metal. If the weld is ground past the base metal the test may be rejected for excessive removal.



After **grinding** down the root and face of the weld, a belt sander to round the square corners can be used, following by a buffing wheel to polish the weld area.

## 6. Test Coupons Stamps:

Generally the certified Weld Inspector uses steel stamps and dies for impact marking on metal, plastic, wood and other materials commonly using a hand held hammer as a percussion press, to mark chosen welding samples.



In general is used a **two-digit number from 1 to 6** for the individual coupon, increasing in number in the direction of the weld. These will be cut from the finished weld later.

All required data per pass, by sample is recorded: **preheat and interpassing** temperatures, voltage, travel speed, electrode stick-out, everything. This system will help the Inspector when left with a pile of bent and broken coupons and have to figure out what went wrong.

As with visual evaluation, if your test samples don't pass **radiographic evaluation**, don't take additional action on the test sample. Figure out what went wrong and make a new test plate.

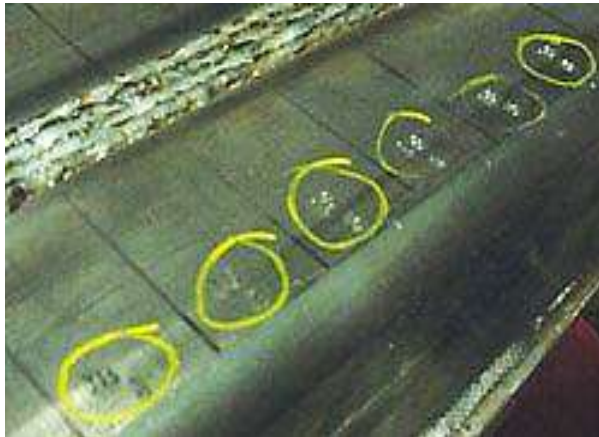

Each test coupon is marked with a steel stamp, to trace each sample back to its corresponding test.

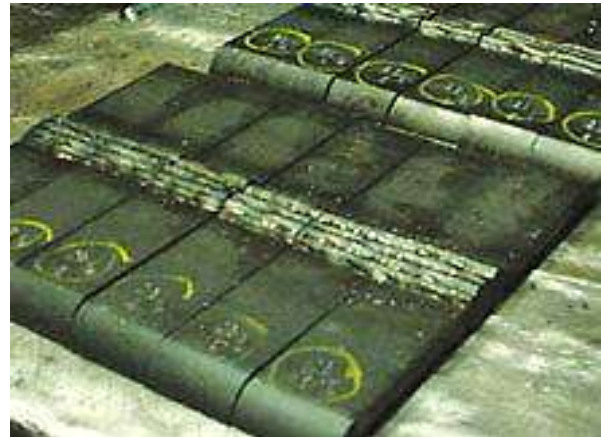

This test sample has been removed from a pipe and is ready to be cut with a saw.

After successfully completed these samples, the Inspector needs to **start cutting** the individual coupons. The correct code or welding specification will dictate the exact coupon size and location.

Typically, are necessary four **(4) coupons for bending** and two **(2) for tensile testing**. Finally, the Inspector will **collect and document all test data** on a Procedure Qualification Report **(PQR)** and develop a **WPS**, according to the code or welding engineering specification.

## 7. Basic Welding Process - Shielded Metal-Arc:

**Filler Metal** - Unless otherwise specified, the electrodes shall be **E-7016, E-7018**.

**Base Metal** - ASTM A709, Grade 36, or 50 or 50 W structural steel, ASTM A-252 steel pipe, ASTM A500 seamless steel structural tubing or A501 structural steel tubing

**Type of current** - AC, DC reverse (electrode positive) or DC straight (electrode negative).

**Joint Design** - Single bevel (with backing) double bevel, square butt welds, or fillet welds, and the thickness of the base metal.

## 8. Basic Welder Qualification:

**Preparation of Base Metal** - For materials up to 4 in. (100 mm) thick a mix surface roughness value of 1000  $\mu$ in. (2  $\mu$ mm) is permitted.

**Joint Welding Design** - Details that influence weld quality such as, welding the web first on H piling. The details determine the soundness, and influence the structural properties of the finished weld joint. Welding Position - flat, horizontal, vertical or overhead.

**Preheat Temperature** - Unless otherwise specified, the preheat temperature shall be as specified in the AWS Welding Code.

**Interpass Temperature** - Equal to minimum preheat temperature at all times. Maximum temperature is not critical provided the heat input during welding is not excessive.

## XIII. LEAK TESTING:

Leak tests are similar to proof tests for closed pressure vessels; the container being tested is filled with a fluid at a specified pressure. The choice of liquid or gas depends on the purpose of the container and the leakage that can be tolerated.

Leaking air or gas can be detected by the sound of the escaping gas, by use of a **soap film that forms bubbles**, or by immersion in a liquid in which the escaping gas forms bubbles.

For hydrostatic or gas tests, a pressure gage attached, indicates leaks by the drop in pressure after the tests begin. Dyes introduced in liquids and tracers introduced into gases can also indicate leakage.

Weld **defects that cause leakage** are not always detected by the usual NDT methods. A tight crack or fissure may not appear on a radiograph, yet will form a leak path. A production operation, such as forming or a proof test, may make leaks develop in an otherwise acceptable weld joint.

A leak test is usually done after the vessel is completed and all the weld joints can be inspected, there will be no more fabricating operations and the inspection should be taken with the empty vessel.

The most common types of leak testings are described below:

**1. The pressure-rise test method:** Is a vessel attached to a vacuum pump evacuating to a pressure of 0.5 psi absolute. The connections to the vacuum pump are sealed off and the internal pressure of the part is measured.

The pressure is measured again after 5 minutes. If the pressure in the evacuated space remains constant, the welds are free of leaks. If there is a pressure rise, at least one leak is present, then the helium-leak test below must be used.

**2. The helium-leak test:** Is more precise than the pressure-rise method and is used to find the exact location of these leaks. Helium-leak testing is not used to inspect large items. This inspection method requires the use of a helium mass spectrometer to detect the presence of helium gas.

The mass spectrometer is connected to the pumping system between the vacuum pump and the vessel being inspected. Then the vessel is evacuated by a vacuum pump to a pressure of less than 50 microns of mercury. The mass spectrometer can detect helium directed at the atmosphere.

If there is a **small jet of helium gas** is aside the weld joint exposed, **there is a leak**. Some of the helium is sucked through the evacuated space and the mass spectrometer immediately indicates the presence of helium.

When **no leak** is present, no indication of gas helium will appear on the mass spectrometer. The exact location of leaks, shows the jet of helium on the surface of the weld joint. If there is an indication of leak, it is at the point where the helium jet is hitting the surface of the weld joint.

**3. Ultrasonic translator detector:** Uses the ultrasonic sounds of **gas molecules escaping** from a vessel under pressure or vacuum. The sound created is in the frequency range of 35,000 and 45,000 Hertz, which is above the range of human hearing is, therefore, classified as ultrasonic. The short wave length of the frequencies permits the use of highly directional microphones.

Any piping or vessel **pressurized or evacuated to a pressure of 3 psi** can be inspected. The operator simply listens to the translated ultrasonic sounds while **moving a hand-held probe** along the weld (as a flashlight). The detectors are simple and require minimum operator training.

**4. The air-soap solution test:** Can be conducted on a vessel **during or after** assembly. The vessel is subjected to an internal gas pressure not exceeding the design pressure. A soap or equivalent solution is applied so that connections and welded joints can be examined for leaks.

**5. Air-ammonia test:** Involves **introducing air** into the vessel until a percent of the design pressure is needed. Anhydrous ammonia is then introduced into the vessel until **55%** of the design pressure is reached. Air is then reintroduced until the design pressure is reached.

Each joint is carefully examined by **using a probe or a swab wetted** with 10N solution of muriatic acid (HCL), a sulphur candle, or sulphur dioxide. A **wisp** of white smoke indicates a leak.

**6. Hydrostatic test:** Use **distilled or demineralized water** having a **pH of 6 to 8** and impurity content not greater than **5 ppm** is used. Traces of water should be removed from the inside before the final leak testing is begun.

**7. Water submersion test:** The vessel is completely **submerged in clean water**. The interior is pressurized with gas, but the design pressure must not be exceeded. The size and number of **gas bubbles** indicate the size of leaks.

**8. Halide torch test:** The vessel is pressurized with a mixture of **50% Freon** and **carbon dioxide** or **50% Freon** and **nitrogen** is used. Each joint is carefully **probed** with a **halide torch** to detect leaks, which are indicated by a change in the color of the flame.

**9. Halogen snifter test:** Use a **Freon inert gas mixture** introduced into the vessel until the design pressure. About **1 ounce** of Freon for every **30 ft<sup>3</sup>** of vessel volume is required. The Inspector passes the **probe** of a **halogen vapor analyzer** over the area to be explored.

This probe is held about 1/2 inch from the surface being tested and is moved at about 1/2 inch per second. Since the instrument responds even to cigarette smoke and vapor from newly dry-cleaned clothing, the air should be kept substantially clean.

## XIV. WELDING EQUIPMENT:

Most field welding machines are portable, that is, they are on a truck and can be moved around. The welding machine is usually a generator driven by a gasoline-powered engine and puts a DC current that may be reversed by changing the leads.

The **welding machine** must contain a gauge or some means of determining the amperage output along with some method of increasing or decreasing the amperage as desired. The leads shall be in good condition with cleaned connections at both ends.



Good quality electrodes are a must. Welding manufacturers produce good quality electrodes that conform to the AWS test requirements, however, this does not ensure their good quality when delivered to the job site.

The welder should discard any damaged electrodes. When using low hydrogen electrodes, he/she must furnish them from undamaged hermetically-sealed containers and have an oven for maintaining their dryness.

The welder's cleaning tools should consist of a chipping hammer and a wire brush. A cold chisel and a hammer may be substituted for the chipping hammer.

A cutting torch must also be available for cutting, beveling and fitting up of the joints of field welds when required. A grinder is also necessary for smoothing out rough cuts and for the removal of a bad weld. Few welders are so skilled with a torch that grinding is not necessary.

The welder must have knowledge of the joint to be welded. Before welding, the inspector should check this knowledge against the information furnished to the Resident Construction Engineer and make certain that it conforms to requirements outlined in these instructions.

### 1. Oxyacetylene Welding Equipment:

Oxy-fuel welding (commonly called oxyacetylene welding, oxy welding, or gas welding) and oxy-fuel cutting are processes that use fuel gases and oxygen to weld and cut metals, respectively. The French engineers Edmond Fouché and Charles Picard became the first to develop oxygen-acetylene welding in 1903.

Pure oxygen, instead of air (20% oxygen/80% nitrogen), is used to increase the flame temperature in a room environment. A common propane/air flame burns at about **3,630 °F (2,000 °C)**, a propane-oxygen flame burns at about **4,530 °F(2,500 °C)**, and an acetylene-oxygen flame burns at **6,330 °F (3,500 °C)**.

Oxy-fuel is one of the oldest welding processes, though in recent years it has become less popular in industrial applications. However, it is still widely used for welding pipes and tubes, as well, as repair work. It is also frequently well-suited, and favored, for fabricating some types of metal-based artwork.

In oxy-fuel welding, a welding torch is used to weld metals. Welding metal results when two pieces are heated to a temperature that produces a shared pool of molten metal, supplied with additional metal called **filler**. Filler material depends upon the metals to be welded.

A cutting torch is used to **heat metal** to adequate temperature. The metal burns in that oxygen and then flows out of the cut (**kerf**) as an oxide slag. Torches that do not mix fuel with oxygen (atmospheric air) are not considered oxy-fuel torches.

Oxy-fuel welding-cutting generally requires two tanks, **fuel and oxygen**. Most metals cannot be melted with a single-tank torch. As such, single-tank torches are typically used only for **soldering** and **brazing**, rather than welding.

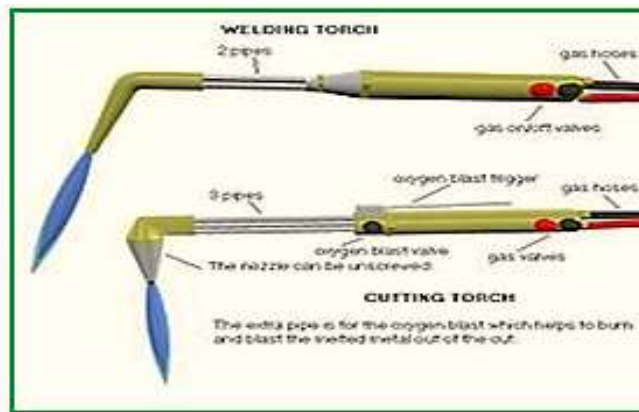

**a. Hydrogen.** Is good for use on **aluminium** and the flame temperature is high, about 2,000 °C for hydrogen gas in air at atmospheric pressure. It can be used at a higher pressure than acetylene and is therefore useful for underwater welding and cutting and heating large amounts of material.

**b. Oxygen.** Is obtained from manifold cylinders and equipped with a master regulator. Regulators, hoses, manifold e piping where are pressure and flow, should be checked to verify and avoid leaks.

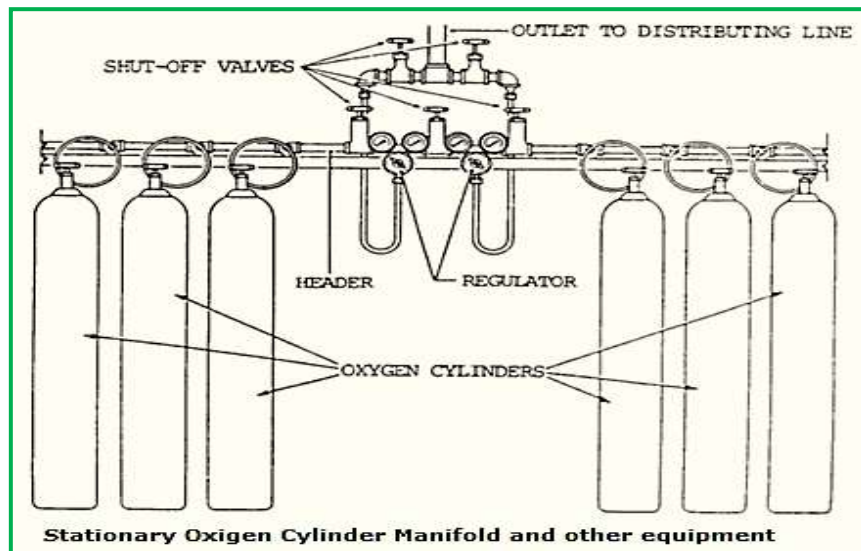

**c. Acetylene.** Acetylene is the primary fuel for oxy-fuel welding and is the fuel for repair work and general cutting and welding. Acetylene gas is shipped in special cylinders shown as below.

The acetylene station, manifold, regulators, hoses, piping, connections through a pipe line should be checked in every detail, before authorize weld operations. After checking every equipment and installation conditions a safety report shall be written or a pattern fulfilled.

Cylinders are very dangerous. The Welding Inspector, together with the safety professional of the manufacturer or in a field pipe-shop, should always inspect every stationary oxyacetylene welding equipment installed where welding operations are conducted, as shown below.

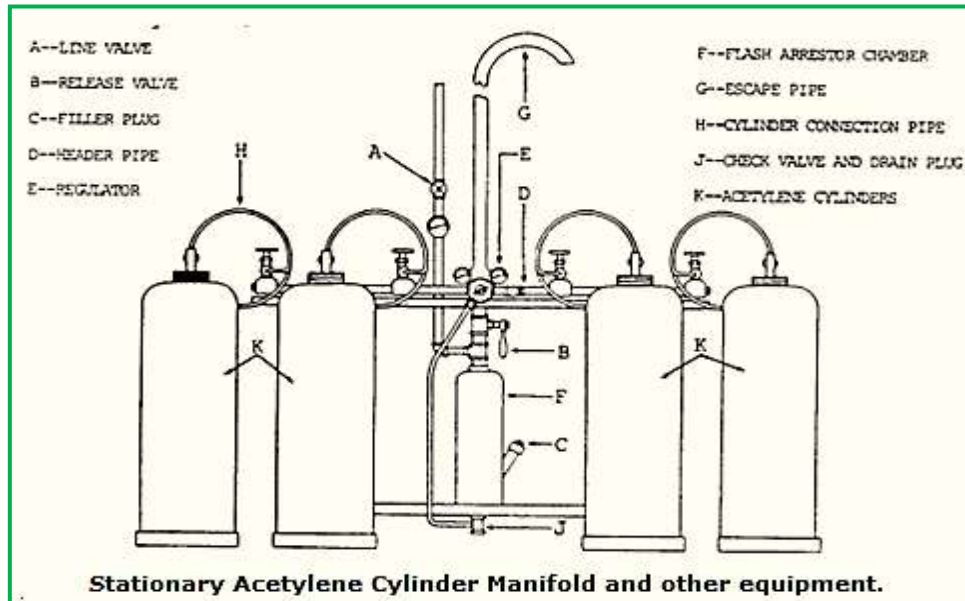

## 2. Gas Metal Arc Welding Equipment:

Gas Metal Arc Welding (GMAW), sometimes referred by Metal Inert Gas (MIG) welding or Metal Active Gas (MAG) welding, is a **semi-automatic or automatic arc welding process** in which a continuous and consumable wire electrode and a **shielding gas** are fed through a welding gun.

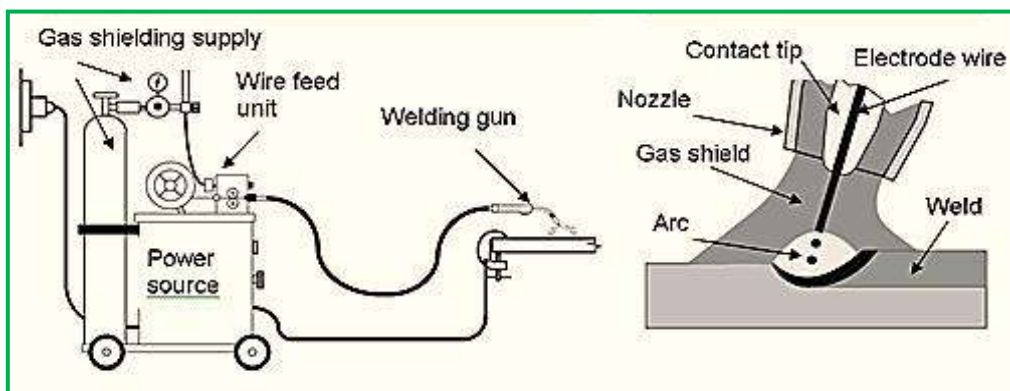

GMAW was originally developed for **welding aluminum** and other **non-ferrous materials** in the 1940s. During the 1950s and 1960s, the use of **semi-inert gases**, as carbon dioxide, the process became more versatile. The four primary methods of metal transfer in **GMAW** are called **globular, short-circuiting, spray, and pulsed-spray**, each with distinct properties, corresponding advantages and limitations.



Today, **GMAW** is the **most common industrial welding process**, preferred for its practicality, speed and the relative ease of adapting the process to robotic automation. A related process, Flux Cored Arc Welding (**FCAW**), often **does not utilize a shielding gas**, instead employs a **hollow electrode wire** that is filled with flux on the inside.

### 3. Regulators – Flowmeters:

A regulator-flowmeter is a device to deliver preset flow of **pressurized shielding gas** to the welding area, with a hose connected between the regulator-flowmeter and a gas valve on the wire feeder.

From the gas valve, the hose connection that is generally part of a gun assembly, delivers shielding gas through the gun head tube and nozzle to the welding area. Regulator and CFH adjustment: A common practice is to start with **12-15 ft<sup>3</sup>/h**.

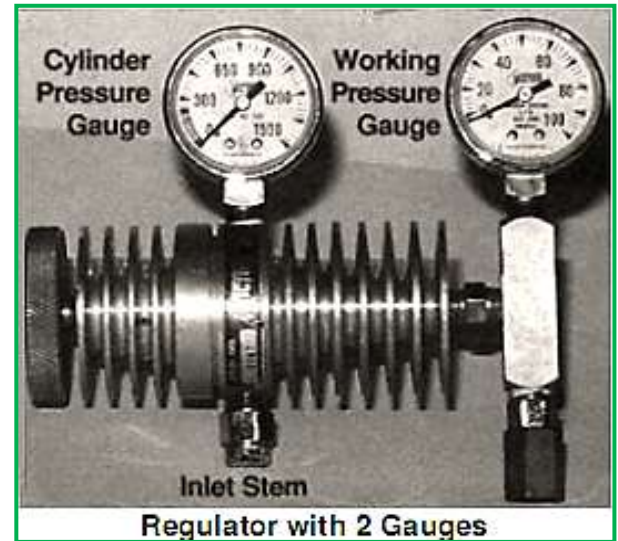
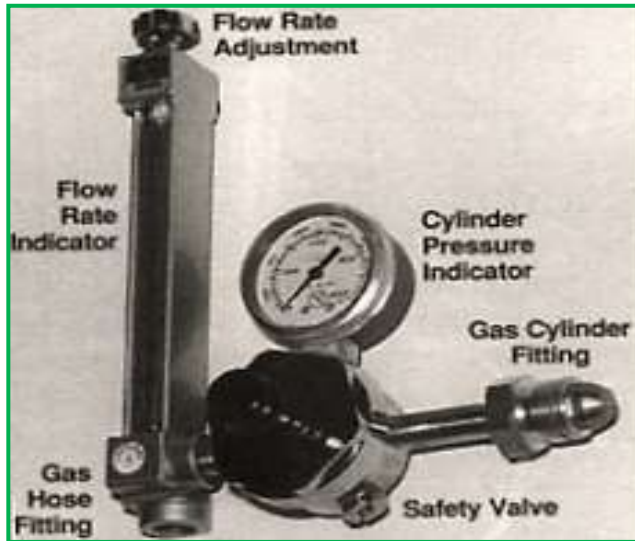

### 4. Shielding Gases:

Shielding gases are necessary for gas metal arc welding to **protect the welding area** from atmospheric gases such as nitrogen and oxygen, which can **cause fusion defects, porosity, and weld metal embrittlement** if they come in contact with the electrode, the arc, or the welding metal.

Using the older Shielded-Metal Arc Welding process (SMAW), the electrode is coated with a solid flux which evolves a protective cloud of carbon dioxide when melted by the arc.

In GMAW, however, the electrode wire does not have a flux coating, and a **separate shielding gas** is employed to protect the weld. This eliminates slag, the hard residue from the flux that builds up after welding and must be chipped off to reveal the completed weld.

The choice of a shielding gas depends on several factors, most importantly the type of material being welded and the process variation being used:

- Pure **inert gases** such as **argon and helium** are only used for nonferrous welding, due not provide adequate weld penetration, cause an erratic arc and encourage spatter.
- Pure **carbon dioxide**, allows deep penetration but encourages oxide formation, which affect the mechanical properties of the weld. The reactivity of spatter is unavoidable and welding thin materials is difficult. As a result, **argon and carbon dioxide** are frequently mixed in a **75%/25% to 90%/10%**.

- Argon is also commonly **mixed with other gases**, oxygen, helium, hydrogen, and nitrogen. The addition of up to 5% oxygen can be helpful in **welding stainless steel**, however, in most applications **carbon dioxide** is preferred.
- Oxygen, in excess, makes the shielding gas oxidize the electrode, which can lead to porosity in the deposit if the electrode and can lead to brittleness in the heat affected zone.
- Argon-helium mixtures are extremely inert, and can be used on **nonferrous materials**. A helium concentration of 50%–75% raises the required voltage and increases the heat in the arc, due to helium's higher ionization temperature.
- Hydrogen is sometimes added to argon in small concentrations (up to about 5%) for **welding nickel and thick stainless steel** workpieces. In higher concentrations (up to 25% hydrogen), it may be used for welding conductive materials such as copper.
- However, hydrogen should not be used on **steel and aluminum** because it can cause porosity and hydrogen embrittlement.
- Helium is also sometimes used as the base gas, with small amounts of argon and carbon dioxide added. However, is less effective in shielding than argon, which is denser than air.

The four primary variations of GMAW have differing shielding gas flow requirements, for the small weld pools of the short circuiting and pulsed spray modes, about **10 l/min (20 ft<sup>3</sup>/h)** is generally suitable, whereas for globular transfer, around **15 l/min (30 ft<sup>3</sup>/h)** is preferred.

The spray transfer variation normally requires more shielding-gas flow because of its higher heat input and thus larger weld pool. Typical gas-flow is approximately **20–25 l/min (40–50 ft<sup>3</sup>/h)**.

The **desirable rate** of shielding-gas flow **depends primarily on weld geometry**, speed, current, the type of gas, and the metal transfer mode being utilized. Welding flat surfaces requires higher flow than welding grooved materials, since the gas is dispersed more quickly.

Faster welding speeds, in general, mean that more gas needs to be supplied to provide adequate coverage. Additionally, higher current requires greater flow, and generally, more helium is required to provide adequate coverage than if argon is used.

## **XV. WELDING FOR JOISTS AND FINISHING OF MACHINING RAILS:**

Unless otherwise authorized by the engineer, any welding to the top flange of **steel members for supporting floor form joists and finishing machine rails** will not be permitted. Welding of hangers and supports to shear studs will be permitted as follows:

1. The welder must be certified and use low hydrogen electrodes and proper preheat.
2. No welding shall be permitted when the ambient temperature of the air is below 32° F (0°C) or when the lowest temperature during the preceding 12 hours has been below 0° F (-18°C).
3. Windbreaks or shields shall be provided when the wind chill factor is strong or cold enough to prevent welding from being carried out in a normal manner without such protection.
4. Welding shall not be permitted on surfaces that are wet or exposed to snow. Arc strikes on bridge flanges must be prevented at all times.

### **1. Welding of Railroad Bridge Deck Floors:**

Railroad bridges that **span highways** are designed with a **steel deck** that covers the bridge and are welded together in the field. The special provisions that accompany railroad bridge lettings usually specify that a welding procedure be submitted for the field welding of the deck.

The **welding procedure for the steel deck** must not only cover the design of the welding joint, but it must also cover the sequence of welding. This welding procedure should receive the approval of the Office of Materials before welding is permitted.

Basically, all the requirements necessary for qualifying the procedure and sequence are in AWS under Sections 2, 3 and 5. The **field inspector should understand the welding procedure** and sequence thoroughly so he may help direct the welder in following the proper steps necessary.

Steel bridge decks involve **longitudinal and transverse groove welds** made in the flat position and are usually on plates of 1/2 in. (13 mm) thickness. Since welding is in both directions a multi-directional stress system can be built in if the procedure and sequence are not properly followed.

## 2. Welding of Reinforcing Steel:

The welding of deformed reinforcing steel is not permitted without the approval of a Structural Materials Engineer. The welding or tack welding of deformed reinforcing steel is detrimental to the mechanical properties of the bar, unless a special welding procedure with proper preheat and interpass temperature is established according to the carbon and manganese content of the bar.

Any field inspector who discovers welding on deformed reinforcing bars should notify their superiors, or with their permission, contact a Structural Materials Engineer. When the welding of deformed reinforcing steel is permitted it is part of the specifications or at a location where the stresses of the steel is almost zero or at a minimum.

## XVI. THE BOILERMAKER:

A **boilermaker** is a trained craftsman who **produces steel fabrications** from plates and sections. The name originated from craftsmen who would fabricate boilers, but they may work on projects as diverse as bridges to blast furnaces to the construction of mining equipment.

### 1. Boilermaking:

Many boilermakers are employed in repairing, re-piping, and re-tubing commercial steam and hot water boilers used for heating and domestic hot water in commercial buildings and multi-family dwellings. Sometimes these boilers are referred to as pressure vessels.

The main **tasks** of boilermakers **involve using oxy-acetylene** gas torch sets **to cut or gouge** steel plate and tubes, followed by Gas Tungsten Arc Welding (GTAW), Shielded Metal Arc Welding (SMAW), or Gas Metal Arc Welding (GMAW) to attach and mend the cut sections of tubes and steel plates.

### 2. Power Piping:

The trade of Boilermaker evolved from the industrial blacksmith and was known in the early 19th century as a "boilersmith". The involvement of **boilermakers in the shipbuilding industry** came about because of the changeover from wood to iron as a construction material.

It was **easier (and cheaper)** to utilize the boilermaker's skills to construct the ship as they were already present in the shipyard constructing iron boilers for wooden steamships. This utilization of skills extended to virtually everything that was large and made of iron, or later, steel.

Welding, fitting, and installing the tubes and accessories that attach to the boiler can also be performed by boilermakers, and is governed by the same organizations as **R Stamp Welding**, except the **Power Piping certification**. The **Power Piping stamp contains two "P"s**, the first can be **inverted** so that it **mirrors** to the second.

### 3. Application:

Boilermaking, welding, and fitting tubes can be a full-time year round project at power plants, since stress fractures, leaks, and rust and corrosion cause a continual need for repair or replacement, and power plants often operate at very high steam pressures.

### 4. R Stamp Welding:

Boiler repair in the United States is governed by the **National Board of Boiler and Pressure Vessel Inspectors**. The ASME under a classification called R Stamp Welding. In order to perform R Stamp, boilermakers are tested and certified in the quality of weld joints through a testing procedure.

**R stamps** are issued to companies that **have existing ASME code stamps** for construction and whose QC system covers repairs or follow the guidelines set up by ASME. Welders identify their welds by stamping their identifying number adjacent to the completed weld with a set of steel stencils.

### 5. Qualification of personnel:

Personnel doing NDT must be qualified according to the requirements of the **ASNT SNT-TC-1A**. If applicable, NDT personnel can be also **certified** under **MIL-STD-410, or MIL-STD-271**.

## XVII. INSPECTION DUTIES:

### 1. General Conditions:

- Understand shop drawings, erection drawings, referenced codes and standards. Review the manufacturer's **Material Test Report (MTR)**. Verify all materials properties and that all materials are readily identifiable and traceable to an MTR.
- Conduct a complete visual examination of the welding area for visible discontinuities. Visual examination should include, as a minimum, the finished conditions of the seam weld.
- For visual examination, the only equipment commonly used is a **magnifying glass** (10x or less) and a **flashlight**. Other tools, such as a **borescope and dental mirrors**, are useful for inspection inside vessels, pipe, or confined areas.
- For structural plates, piping, wrought and cast steel, conduct a complete visual examination of surfaces for visible fabrication defects or discontinuities.
- Verify that all applicable welders, welding operators or tack welders are **qualified for the job** and the qualifications reports are available, current, and accurate.
- Verify that a written **Welding Procedure Specification (WPS)** is available for each type of weld, in compliance with all requirements, and that the WPS has been approved as required.
- Evaluate all **Procedure Inspection Tests (PIT)** and verify that the **Procedure Qualification Records (PQR)** is compliant with all applicable requirements.
- Verify that all welding consumables comply with the quality approved documents and the **Welding Procedure Specification (WPS)**. Verify that all **electrodes are properly stored**.
- Verify that the welding current and voltage are within the **WPS parameters** by using a **calibrated hand-held volt/amp meter**. Readings should be taken as near the arc as possible.

- Verify joint preparation, assembly practice, preheat temperatures, interpass temperatures, welding techniques, welder performance, and **Post-Weld Heat Treatment (PWHT)** meet the requirements of the quality approved documents, WPS, and applicable AWS code.
- Verify size, length, and location of all welds. Verify that all welds conform to the requirements of the AWS code. Weld size and contour **shall be measured with suitable gauges**.
- Execute a distinguishing mark in completed welds and joints just inspected and accepted using a tag or a dye stamp. The mark shall include; inspector's initials, inspection date and status.
- Schedule or notify those responsible for the **Nondestructive Testing (NDT) technicians** in a timely manner, after visual inspection and acceptance is complete, and the assembly has cooled.

## 1) Inspection Reporting Duties:

- Daily inspection reports must describe the inspection process and document all inspection duties as above. Reports shall include a systematic list of accepted and rejected welds, parts, or joints.
- Reports shall reference the details on the quality approved documents and the **Procedure Inspection Tests (PIT)** used as basis for inspection.
- Inspection reports must state that the work was inspected and met the requirements of the approved documents. Reports indicating non-compliance shall be submitted immediately.
- At the conclusion of the work, the welding inspector is required to sign and submit a clear report.

## 2) Inspection Documentation Experience:

- Experience in **documentation** with a direct relationship to weldments fabrication according to American or European standards.
- Experience in the **development** of plans, drawings, procedures, inspection requirements, acceptance criteria, and specifications for weldments.
- Experience in **planning, control**, supervision, and application of base metals and filler metals in the preparation and completion of production weldments.
- Experience in **fabrication**, construction, and supervision of personnel in erection of welded assemblies or subassemblies.
- Experience in the **detection and measurement** of weld discontinuities by application of visual or other nondestructive evaluation processes to a written procedure.
- Experience in **supervision** of personnel engaged in material and weld examination.

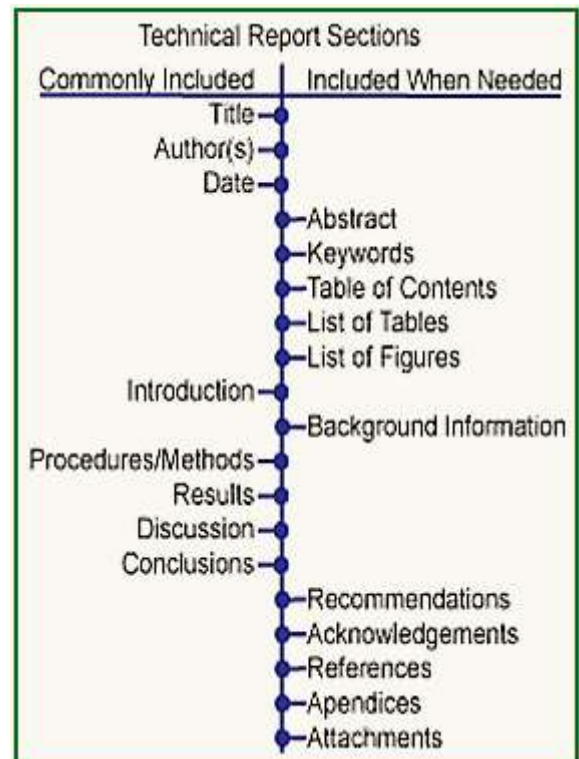

- Experience in **repair welding**, or supervision of personnel performing weld repairs, preparation of written procedures for welding, nondestructive evaluation, or destructive tests.
- Experience in the **qualification of welders** or welding procedures, welding design functions as specified in the applicable codes, standards or specification.
- Experience in **operational techniques** and activities used to fulfill quality control requirements for weldments and using a quality system.
- Experience in teaching the occupational **skill of welding** or subjects related to welding; its application, control, materials, and processes.

### 3) Technical Reports:

NDT personnel write technical reports for two primary purposes: to communicate information to customers, colleagues and managers, and to document the equipment and procedures used in testing. The results are obtained so that the work can be repeated.

### 4) Qualities of Good Technical Reports:

Include all the details needed to fully document and explain the work but keep it as brief as possible. Conciseness is especially important in the abstract and conclusion sections. The personal style of the writer should be secondary to the clear and objective communication of information. Writers should, however, strive to make their reports interesting and enjoyable to read.

### 5) Accuracy, Objectivity and Clarity:

Values must be transferred correctly into the report and calculations are done properly. Mistakes may cause the reader to doubt other points of the report and reflect on the professionalism of the author.

Conclusions should be drawn solely from the facts presented. Opinions and conjecture should be clearly identified if included at all. Deficiencies in the testing or the results should be noted. Readers should be informed of all assumptions and probable sources of errors if encountered.

The text must be clear and unambiguous, mathematical symbols must be fully defined, and the figures and tables must be easily understood. Clarity must be met from the readers' point of view.

When photographs are included in a report, a scale or some object of standard size should be included in the photograph to help your readers judge the size of the objects shown.

### 6) Continuity:

Don't add new information about the procedure followed in the discussion section. Information about the procedure belongs in the procedure section. The same three step approach for developing an effective presentation can be used to develop an effective report:

- Introduce the subject matter (tell readers what they will be reading about)
- Provide the detailed information (tell them what you want them to know)
- Summarize the results and conclusions (re-tell them the main points)

### 7) Welding Inspector Knowledges:

Welding experience is valuable to an inspector but not the only one of the necessary. The inspector should have sufficient **knowledge** of the welding process to enable him/her to know what defects are most likely to occur. Should be **familiar with procedure specifications**, and know how to apply.

## 8) Knowledge of Test Methods:

It is essential that the inspector have some knowledge of the test methods to a better understanding of why one welder may be qualified to weld and another welder is not. This knowledge also enables the inspector to understand the limitations that may be imposed on some welders.

## 9) Knowledge of Reports and Quality Procedures:

Prepare reports and understand what is SMAW, SAW, OFW, RW, GTAW, FCAW, GMAW, PAW, SW, ESW, Thermal Spraying, Soldering, Mechanical Cutting, Thermal Cutting/Gouging and Brazing Welding. Understand VT, MT, AET, UT, PT, ET, RT, LT, quality procedures, quality audits and surveillance, fundamentals of welding metallurgy, welding symbols, drawings and related documents.

## 10) Knowledge of Standards:

Verify base material, verify filler metal, verify filler metal storage/handling, verify inspection records, verify proper documentation, verify base material and filler metal compatibility, certify documented results, verify procedure qualification records, verify welding procedure, verify NDE procedures.

## 11) Knowledge of Welder Qualifications:

Verify welding equipment appropriateness, verify edge preparation, verify joint geometry, witness procedure qualification, verify welder procedure qualification, (review and approve welding procedures), develop welding procedures, verify welder safety procedures.

## 12) Knowledge of General Inspection:

Perform visual examinations, verify examination procedure, review examination results, develop visual inspection procedures (before, during, and after welding), provide NDT inspection planning and scheduling (before, during, and after a project).

Review welding inspection reports, verify implementation of nondestructive and destructive methods, visual inspection requirements, prepare NDT requirements, report results of quality inspection, prepare destructive testing procedures.

## 13) Inspector Duties:

Witness welder performance qualification, verify welder qualification, verify welder qualification records and request welder performance requalification. The inspector duties will follow the general headings below:

1. Interpretation of the Plans and Specifications
2. Verification of Welder Records and Welding Procedures
3. Verification of Written Welding Procedures
4. Production Welding Checks
5. Keeping Records and Reporting
6. Selection of Test Samples

### 13.1) Records and Reports:

The inspector should have the skills required to review a **Procedure Qualification Record (PQR)** and a **Welding Procedure Specification (WPS)** and to be able to determine the following:

- a) Determine if procedure and qualification records are in compliance with applicable **ASME Boiler and Pressure Vessel Code** and additional requirements of **API570**.

b) The weld procedure review will include a **Weld Procedure Specification (WPS)** and a **Procedure Qualification Record (PQR)**.

c) Determine if all required essential and nonessential variables have been properly addressed. (Supplemental essential variables will not be a **part of the WPS/PQR**)

d) Determine that the number and type of mechanical tests that are listed on PQR are the proper tests, and whether the results are acceptable.

e) Weld Procedure Review SMAW, GTAW, GMAW, and SAW:

- The WPS should be to be reviewed will be supported by a single PQR
- Filler metals will be limited to one per process for SMAW, GTAW, GMAW, or SAW
- The PQR will be the supporting PQR for the WPS
- Base metals will be limited to P1, P3, P4, P5, and P8
- Dissimilar base metal joints, and dissimilar thicknesses of base metals will be excluded.
- Special weld processes such as corrosion resistant weld metal overlay, hard facing overlay, and dissimilar metal welds with buttering of ferritic member will be excluded
- For P1, P3, P4, and P5, for the purpose of the examination the lower transition temperature will be 13,300°F and the upper transformation temperature will be 16,000°F.

### **13.2) Safety and Quality Assurance:**

Verify safety requirements compliance, develop safety procedures and policies. Perform audits and surveillance, develop quality assurance plans, prepare base material control requirements, prepare weld consumable, prepare audit and surveillance plans, prepare documentation control requirements.

### **13.3) Project Management:**

Review contract requirements, review vendor proposal compliance, prepare weld inspection, bid specifications, prepare purchase specifications, determine vendor capacity and capability, select vendors, verify and inspect products storage.

### **13.4) Training:**

Develop and provide a training program, develop visual inspection training, verify implementation of visual inspection training, develop quality assurance program, verify implementation of quality assurance training, provide guidance to inspectors for maintaining their individual qualifications.

## **XVIII. STANDARD SPECIFICATIONS FOR WELDING PROCEDURES:**

The sole purpose of welding procedures is to describe the details that are to be followed in the welding of specific materials or type of joint. The following is a **list of standard specifications** that are normally covered in welding procedures specification for all welding processes.

### **1. Nondestructive Examination - ASME Section V:**

#### **A. Article 1, General Requirements:**

The Welding Inspector should be familiar with, and understand;

- a) The Scope of Section V;
- b) Rules for use of Section V;
- c) Responsibilities of the Owner / User and Subcontractors;
- d) Calibration, Inspection and Examination;
- e) Record Keeping Requirements;



## **B. Article 2, Radiographic Examination:**

- a) The Scope of Article 2 and General Requirements,
- b) The Rules for Radiography applied on butt welded seams:
  - Required Marking;
  - Type, Selection, Number, and Placement of IQI's;
  - Allowable Density and Density Ranges;
  - Control of Backscatter Radiation;
- c) Recording of inspection;

## **C. Article 6, Liquid Penetrant Examination (Including mandatory appendices II / III):**

General rules for applying the Liquid Penetrant Method, but not limited to the following:

- a) The Scope of Article 6,
- b) General requirements such as but not limited to:
  - Procedures
  - Contaminants
  - Techniques
  - Examination
  - Interpretation
  - Documentation and record keeping

## **D. Article 7, Magnetic Particle Examination (Yoke and Prod techniques only):**

General rules for applying the Magnetic Particle Method, but not limited to the following:

- a) The Scope of Article 7,
- b) General requirements such as but not limited to:
  - Procedures
  - Techniques (Yoke and Prod only)
  - Calibration
  - Examination
  - Interpretation
- c) Documentation and record keeping

## **E. Article 9, Visual Examination:**

General rules for applying Visual Examination method, but not limited to the following:

- a) The scope of Article 9,
- b) General requirements such as but not limited to:
  - Procedures
  - Physical requirements
  - Procedure/technique
  - Evaluation
- c) Documentation and record keeping

## **F. Article 10, Leak Testing (Mandatory Appendix I - Bubble Test):**

General rules for applying the Leak Testing method, but not limited to the following:

- a) The scope of Article 10,
- b) General requirements such as but not limited to :
  - Calibration
  - Test and Evaluation
- c) Documentation and record keeping

## **G. Article 23, Ultrasonic Standard Method, Section SE-797 only – standard practice:**

The inspector should be familiar with and understand;

- a) The Scope of Article 23, Section SE797,
- b) The general rules for applying and using the Ultrasonic method
- c) The specific procedures for Ultrasonic thickness measurement as contained in paragraph 7.

## **H. ASME B31.3 and API570: General nondestructive examination requirements:**

General rules for NDE (Chapter VI) ASME B31.3 and general rules for NDE in API Standard 570.

### **a. API RP 577, Welding Inspection and Metallurgy:**

1. Definitions;
2. Welding Inspection;
3. Welding Processes;
4. Welding Procedures;
5. Welding Materials;
6. Welder Qualifications;
7. Nondestructive Examination;
8. Metallurgy;
9. Refinery and Petrochemical Plant Welding Issues;
10. Terminology and Symbols;
11. Actions to Improperly made Production Welds;
12. Welding Procedure Review;
13. Guide to common filler metal selection;
14. Example reports of RT results.

### **b. General Welding Specifications:**

- API 1104 - Welding of Pipelines and Related Facilities
- AWS A3.0 - 2001 - Standard Welding Terms and Definitions
- ANSI/AWS QC1- 96 - Standard for AWS Certification of Welding Inspectors
- AWS A5.32/A5.32M- 97 - Specification for Welding Shielding Gases
- ANSI/AWS A5.4- 92 – Specific. for Stainless Steel Electrodes for Shielded Metal Arc Welding
- ANSI/AWS A5.6- 84 – Spec. for Covered Copper and Copper Alloy Arc Welding Electrodes
- ANSI/AWS 5.9- 93 - Specification for Bare Stainless Steel Welding Electrodes and Rods
- ANSI/AWS 5.8- 92 - Specification for Filler Metals for Brazing and Braze Welding
- ASME Sec IX - Welding and Brazing Qualifications – Boiler and Pressure Vessel Code
- ANSI Z49.1 Safety in Welding, Cutting, and Allied Products
- AWS A1.1 Metric Practice Guide for the Welding Industry
- AWS A2.4 Standard Symbols for Welding, Brazing, and Nondestructive Examination
- AWS A3.0 Standard Welding Terms and Definitions
- AWS B1.10 Guide for the Nondestructive Examination of Welds
- AWS B1.11 Guide for the Visual Inspection of Welds
- AWS B2.1 Specification for Welding Procedure and Performance Qualification
- AWS B4.0 Standard Methods for Mechanical Testing of Welds
- AWS B5.1 Specification for the Qualification of Welding Inspectors
- AWS QC1 Standard for AWS Certification of Welding Inspectors
- AWS Certification Manual for Welding Inspection
- AWS Welding Inspection Handbook
- ISO 9001 Quality Management Systems—Requirements SWI
- ASNT SNT-TC-1A Personnel Qualification and Certification in Nondestructive Testing

## **XIX. INSPECTOR CERTIFICATIONS:**

### **1) Levels of Certification AWS B5.1:2003:**

There are three levels of qualifications for welding inspection personnel. These levels are:

**AWI** - Associate Welding Inspector;  
**WI** - Welding Inspector;  
**SWI** - Senior Welding Inspector.

#### **1.1) Associate Welding Inspector (AWI):**

Shall be a **high school graduate**, or hold a state or military **approved high school equivalency** diploma. Shall have a **minimum of two years' experience** in an occupational function with a direct relationship to weldments fabricated to national or international standards and directly involved in one or more of the areas.

#### **1.2) Welding Inspector (WI):**

Shall be a **high school graduate**, or hold a state or military **approved high school** equivalency diploma. Shall have a **minimum of 5 years' experience** in an occupational function with a direct relationship to welded assemblies fabricated to national or international standards and be directly involved in one or more of the areas.

#### **1.3) Senior Welding Inspector (SWI):**

Shall be a **high school graduate**, or hold a state or military **approved high school equivalency** diploma. Shall have a **minimum of 15 years' experience** in an occupational function with a direct relationship to welded assemblies fabricated to national or international standards and be directly involved in one or more of the areas.

### **2) Written Test Requirements:**

Shall be performed an applicable **AWI, WI, or SWI** examination. Individuals failing one Part of the examination shall have to retest on all Parts. The examination includes the following Parts:

- 1) Test on the requirements of a code, standard or specification. A test on fundamental principles including, but not limited to: welding processes, NDT examination, safety, quality assurance, inspector's duties, weld discontinuities, welding symbols, joint design, mechanical properties of metals, and basic on-the-job mathematics.
- 3) A test on practical application of welding inspection knowledge including, but not limited to: welding procedure qualification, welder qualification, mechanical testing, drawing and specification compliance, welding examination, and nondestructive testing processes.

## **XX. SAFETY AND PRECAUTIONS:**

As in any welding process, **safety precautions** are very important. All information relating to the safe operation of the welding equipment and process must be fully understood before beginning work. A careless welder who does not observe some simple rules can cause a dangerous situation for everyone. The process of **arc welding creates several hazards** which must be guarded against.

If the welding machine has the characteristics of a transformer or a motor-generator design, electrical energy is required as primary power to operate it. Useful safety information can be found in the Owner's Manual that comes with each item of welding equipment.

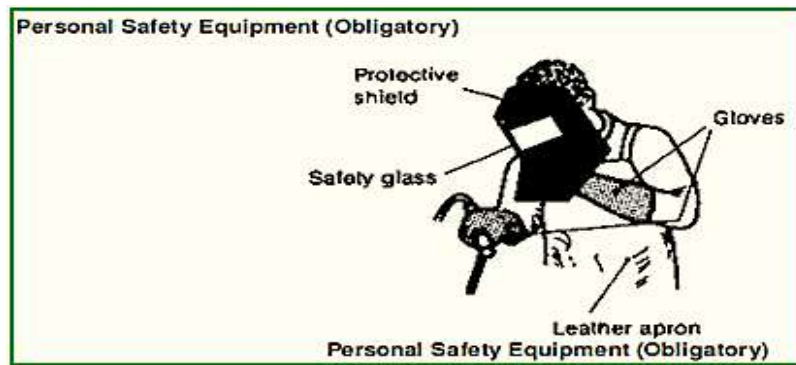

## 1. Electrical Shock:

Welders must be concerned about the possibility of electrical shock. It should be remembered that electricity will always take the path of least resistance. A welder should never weld while standing in water. If wet working conditions exist, certain measures should be taken. Such measures include standing on a dry board or a dry rubber mat.

Likewise, the welding equipment should not be placed in water. Gloves and shoes must be kept dry. Even a person's perspiration can lower the body's resistance to electrical shock.

### 1.1. Important Rules:

- Wear dry, hole-free insulating gloves and body protection;
- Insulate yourself from work and ground using dry insulating mats or covers;
- Disconnect input power or stop engine before installing or servicing this equipment;
- Properly install and ground the equipment including the welding table;
- When making input connections, attach proper grounding conductor first;
- Turn off all equipment when not in use;
- Do not use worn, damaged, undersized, or poorly spliced cables;
- Do not touch electrode if in contact with the work or ground;
- Use only well maintained equipment. Repair or replace damaged parts at once;
- Keep all panels and covers securely in place;
- Avoid poor connections, bare spots on cables or wet conditions.

## 2. Arc Rays:

- Several possible hazards exist due to the electric arc, infrared and ultraviolet rays.
- The light and rays can produce a burn more stronger than sunburn;
- Any exposed skin can be quickly burned by these rays.

## 3. Fumes and Gases:

- The welder must always keep good ventilation and not breathe the fumes;
- Use of protective screens or barriers to protect others from flash and glare;
- Should be always warning advices to others not to watch the arc;
- Approved standards safety glasses and side shields are recommended.

## 4. Fire or Explosion:

- Welding can cause fire or explosion;
- Protect yourself and others from flying sparks and hot metal;
- Welding should not be made where flying sparks can strike flammable material;
- Remove all flammables near of the welding arc;
- A fire extinguisher should all the time be available.

## 5. Flying Sparks:

- Flying sparks and hot metal can cause injury;
- Chipping and grinding cause flying metal. Remove slag after welds cool down;
- Wear protective clothing such as heat resistant jackets, aprons etc.;
- Do not wear clothing stained with oil and grease that may burn if ignited by the arc;
- To protect the feet, high top leather shoes are recommended.

## 6. Safety with Gas Cylinders:

On an oxyacetylene system there will be three types of valves, **the cylinder valve, the regulator valve, and the torch valve**. There will always be a set of three valves for each system, since the gas in the cylinders is at high pressure.

A broken off valve will release extremely high pressures, which could cause the cylinder to become an extremely deadly flying missile. For this reason, never move an oxygen tank around without its valve cap screwed in place.

An oxygen tank is especially dangerous for the reason that the oxygen is at a pressure of **21 MPa (3000 lb./in<sup>2</sup> = 200 atm)**. Oxygen cylinders are generally filled to approximately **2200 psi**.

The regulator **converts the high pressure gas to a low pressure** stream suitable for welding. It is not recommended to directly use high-pressure gas.

Pressurized cylinders must at all times be handled with great care. **Shielding gases** such as carbon dioxide, argon and helium are **nonflammable** and **no-nexplosive**.

The subtle **safety points** when using **gas cylinders** that should be followed are:

- More than 1/7 the capacity of the cylinder should not be used per hour. This causes the acetone inside the acetylene cylinder to come out of the cylinder and contaminate the hose and possibly the torch.
- Acetylene is dangerous above 15 psi pressure. It is unstable and explosive;
- Proper ventilation when welding will help to avoid large chemical exposure;
- Oxygas welding station - keep cylinders and hoses away from the flame;
- Keep cylinders away from any welding or other electrical circuits;
- Never allow a welding electrode to touch any cylinder;
- Install and secure cylinders in an upright position by chaining them to a wall, a portable cart or a stationary support to prevent from falling.

## 7. Chemical Exposure:

Exposure to certain metals, metal oxides, or carbon monoxide can often lead to severe medical conditions. Damaging chemicals can be produced from the fuel, from the work-piece, or from a protective coating on the work-piece.

By increasing ventilation around the welding environment, the welders will have much less exposure to harmful chemicals from any source. The most common fuel used in welding is acetylene, which has a two-stage reaction. The primary chemical reaction involves the acetylene disassociating in the presence of oxygen to produce heat, carbon monoxide, and hydrogen gas:  $C_2H_2 + O_2 \rightarrow 2CO + H_2$ .

A secondary reaction follows where the carbon monoxide and hydrogen combine with more oxygen to produce carbon dioxide and water vapor. When the secondary reaction does not burn all of the reactants from the primary reaction, the welding process produce large amounts of carbon monoxide.

Exposure to **zinc oxide fumes** can lead to a sickness named "**metal fume fever**". This condition rarely lasts longer than 24 hours, but is still unpleasant. Generally influenza, fevers, chills, nausea, cough, and fatigue are common effects of high zinc oxide exposure.

## 8. Complete Safety Equipment for Welders:



## 9. Flashback:

Flashback is the condition of the flame propagating down the hoses of an oxy-fuel welding and cutting system. To prevent this, a **flashback arrestor** is employed. The **flame burns backwards** into the hose, causing a popping or squealing noise.

It can cause an **explosion in the hose** with the potential to injure or kill the operator. Using a lower pressure than recommended can cause a flashback.

## 10. The Importance of Eye Protection:

Proper protection such as welding goggles should be worn at all times, including to protect the eyes against glare and flying sparks. Special safety eyewear must be used, both to protect the welder and to provide a clear view through the yellow-orange flare given off by the incandescing flux.

The **goggles eye protection** must be according to ANSI Z87-1989 - Safety Standards for Special Purpose Lens, designed especially for gas-welding aluminum that cuts the sodium orange flare completely and provides the necessary protection from ultraviolet, infrared, blue light and impact.

## 11. Hot Work Procedures:

- The Inspector must ensure that all relevant check lists, certificates and **work permits (WPs)** for hot work have been issued. If work is being done outside the workshop, an assistant protected in the same manner as the welder, should accompany him.

- If work has been done inside a **confined space** the assistant should be placed outside, within view of the welder and with possibility to cut off gas and power supply. (Gas quick couplings and unlocked safety cable connectors may act as emergency cut-offs).

## 12. Operator and Assistant Protection:

- The Inspector should check the welder safety clothes, as well. Welder cannot wear clothes of highly combustible materials or wet clothes, and do not carry combustible material, e.g. matches, lighters, oily rags.
- Welding gloves should always be used, and when necessary also use additional leather clothing for protection against sparks, heat and electric shock. The welder must use head and face protection (helmet, shield, goggles) and ensure that filter glasses are unbroken and have the correct shade.

## XXI – WELDER RECORD QUALIFICATIONS – SAMPLES:

### 1. Procedure Qualification Record (PQR):

Procedure Qualification Record (PQR)				Sheet 1 of 2
Code: AWS D1.1				
Company Name:			PQR No.:	DEMO-PQR
Welding Process:	Process Type:	Position:	WPS No.:	DEMO-WPS
SMAW	Manual	Flat		
Base Metal Part I (Material Spec., type or grade):		Base Metal Part II (Material Spec., type or grade):		
ASTMA 516 Grade 60		ASTMA 516 Grade 60		
Thickness and Diameter (Pipe): mm (in)		Filler Metals:		
Thickness of Test Coupon: 60 mm (2.36 in.), Plates		AWS Classification/AWS Specification:		
Diameter of Test Coupon: N/A		E7014		
		A5.1		
Joint Details/Sketch:				
				
Joint Design Used: mm (in)				
Butt Opening G: 0 to 1/8 in.    Root Face RF: 3 mm (1/8 in.)    Groove Angle: 60° (both sides)    Radius (I-I): N/A				
Well Type:		Joint Type:		
Complete Joint Penetration Groove Weld		Butt Joint		
Backing Option:	Backing Material:	Back Gouging Method:		
Back-gouge to sound metal	NA	Mechanical (Grinding)		

**Electrical Characteristics:**

Current Type/Polarity: DCEP

Transfer Mode (GMAW): N/A

Tungsten Electrode (GTAW):

Type: N/A

Size: mm (in) N/A

**Shielding:**

Gas Composition (Flux for SAW): N/A

Gas Flow Rate: lt/min. (CFH) N/A

Gas Cup Size: N/A

**Welding Procedure**

Weld Layers	Pass No.	Process	Filler Metal Classification	Filler Metal Diameter mm (in)	Current Amps	Current Type & Polarity	Wire Feed Speed (in/min)	Volts	Travel Speed (in/min)	Remarks [Heat Input] J/mm (J/in)
1 to 2	1 to 3	SMAW	E 7018	4.0 mm (5/32)	160-200	DCEP	N/A	24-26	5-10 (in/min)	Root Pass
2 to n	4 to n	SMAW	E 7018	4.8 mm (3/16)	220-250	DCEP	N/A	24-26	5-10 (in/min)	Fill and Cap
Side 2										Backgouged
1 to n	1 to n	SMAW	E 7018	4.8 mm (3/16)	220-250	DCEP	N/A	24-26	5-10 (in/min)	Fill and Cap

**Technique:**Stringer or Weave Bead: *Stringer and Weave Bead*Contact Tube to Work Distance: *N/A*Initial Interpass Cleaning: *Wire Brush, Grinding*Peening: *Not Required*Number of Electrodes: *Single*Electrodes Spacing: *Longitudinal: N/A**Lateral: N/A**Angle: N/A***Heat Treatment:**Preheat Temp. Min °C (°F): *150 °C*Interpass Temp. Min/Max °C (°F): *150 °C*Postweld Heat Treatment: Temp. °C (°F): *600 to 620 °C*Time: *1 Hour per in.***Additional Notes:**

See Postweld Heat Treatment (PWHT) Specification No. PWHT-SMAW-01

**Heat Treatment (AWS Code's Guideline):****PREHEAT TABLE:**

AWS D1.1, Table 3.2 Prequalified Minimum Preheat and Interpass Temperature °F (°C):

Thickness 3 to 20 mm (1/8 to 3/4 in.) incl: 32°F (0°C)

Over 20 thru 38 mm (3/4 to 1-1/2 in.) incl: 50°F (10°C)

Over 38 thru 65 mm (1-1/2 to 2-1/2 in.) incl: 150°F (65°C)

Over 65 mm (2-1/2 in.): 225°F (110°C)

For SMAW process, above preheat data is with low hydrogen electrodes.

When the base metal temperature is below 32°F (0°C), preheated to a minimum of 70°F (20°C)

Preheat and interpass temperature shall be sufficient to prevent cold cracking.

Guideline on Alternative Methods for Determining Preheat/Interpass: See Annex XI of AWS D1.1

**POSTWELD HEAT TREATMENT:**

PWHT requirements shall be based on Welding Procedure Specification (WPS).

AWS D1.1, 5.8 Stress-Relief Heat Treatment: Where required by the contract drawings or specifications, welded assemblies shall be stress relieved by heat treating.

(See AWS D1.1, 5.8.1, Requirements for stress-relief treatment;

Table 5.2, Minimum Holding Time; Table 5.3, Alternate Stress-Relief Heat Treatment)

See AWS D1.1, 5.8.3, Steels Not Recommended for PWHT



## 2. Welding Procedure Specification (WPS):

### Welding Procedure Specification (WPS)

Code: AWS D1.1

Company Name:

Identification #:

GMAW-DEMO

WPS Prequalified:

Yes

Welding Process:

GMAW

Process Type:

Semi-Automatic

Position(s):

Flat

Supporting PQR No.(s):

N/A

Base Metal Part I (Material Spec., type or grade):

Steel in Group I and II of Table A1-AWS D1.1

Base Metal Part II (Material Spec., type or grade):

Steel in Group I and II of Table A1-AWS D1.1

Qualified Thickness and Diameter Range:

Groove (Fillet): mm (in)

$T \geq 6 \text{ mm } (1/4 \text{ in})$

Filler Metals:

AWS Classification/AWS Specification:

E70C-6M114

AS18

Joint Details/Sketch:

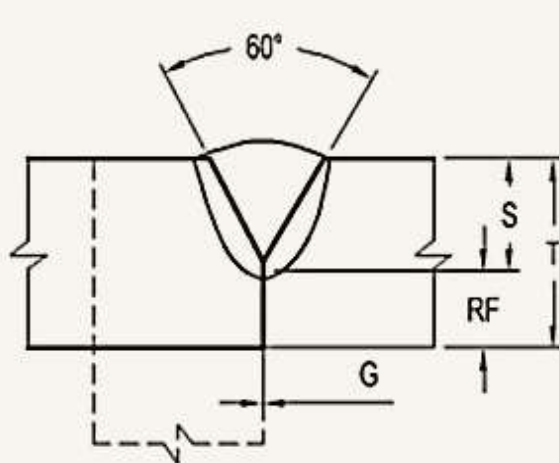

BC-P2-GF

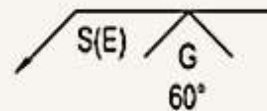

$RF \geq 3 \text{ mm } (1/8 \text{ in})$

$G=0$

$E=S$

$T \geq 6 \text{ mm } (1/4 \text{ in})$

Table 3.4 of AWS D1.1

T	S	E min
in	in	in
$T = 1/4$	As specified in the drawing	$1/8$
$T \leq 1/2$		$3/16$
$T \leq 3/4$		$1/4$
$T \leq 1-1/2$		$5/16$
$T \leq 2-1/4$		$3/8$

Joint Design Used: mm (in)

Root Opening G: 0

Root Face RF:  $\geq 1 \text{ mm } (1/8 \text{ in})$

Groove Angle:  $60^\circ$

Radius (R): N/A

Weld Type:

Partial Joint Penetration Groove Weld

Joint Type:

Butt Joint Corner Joint

Backing Option:

Welded without backing

Backing Material:

N/A

Back Gouging Method:

N/A

### 3. Welding Performance Qualification Record (WPQR):

## Welding Performance Qualification Record (WPQR) Welding Code: AWS D1.1

Company Name:

Company Address:

Welder's Name: *Elvis Tom Jones*

Identification No: *ETJ-2005*

Type of welder: *Welder*

Welding Performance Qualification Record WPQR No. *DEMO-SMAW-WPQR*

Qualification Date: *12, 12, 2005*

Welding Procedure Specification WPS No. *DEMO-SMAW-WPS*

Rev. *0*

#### BASE METALS USED

Material Specification, Type or Grade: *ASTM A 36*

Plate  Pipe  Box Tube  Sheet

Welded to

Material Specification, Type or Grade: *ASTM A 36*

Plate  Pipe  Box Tube  Sheet

#### Variables

#### Actual Values Used

#### Qualification Range

Variables	Actual Values Used	Qualification Range
Welding Process	SMAW	SMAW
Process Type	Manual	Manual
Electrode (Single or Multiple)	Single	Single
Current Type Polarity	DCEP	
Backing (Yes or No)	Without backing	With or without
Welding Position :		
Groove	2G	F, H (Plate, Pipe, Box Tube)
Fillet		F, H (Plate, Pipe, Box Tube)
Vertical Progression	n/a	n/a
Plug or Slot Welds	n/a	2G (Plate)
Base Metals Thickness:		
Groove	3/8 in. (10 mm)	1/8 in. (mm) to 3/4 in. (20 mm)
Fillet	n/a	any thickness
Plug or Slot Welds	n/a	any thickness
Base Metals Diameter (Pipe or Tube):		
Groove	n/a	24 in. (600 mm) OD and over
Fillet	n/a	24 in. (600 mm) OD and over
Filler Metal Specification (SFA)	A5.1	
Filler Metal Classification (AWS Classified)	E7018	Any AWS A5 Class Approved
Filler Metal F-Number	4	4, 3, 2, 1
Gas Flux (SAW)	n/a	n/a
Other Variable (coating type/thickness, etc.)	n/a	n/a