



# SURFACE WATER TREATMENT OPERATOR CERTIFICATION MANUAL

Kentucky Department of Environmental Protection

**Division of Compliance Assistance**

300 Fair Oaks Lane • Frankfort, KY 40601

Phone: 502.564.0323 • **800.926.8111** • Fax: 502.564.9720

Email: envhelp@ky.gov • Website: <http://dca.ky.gov>

*Revised January 8, 2012*

## ***Certification and Licensing Program***

### **Mission**

Promote responsible environmental stewardship.

### **Goal**

Provide operators with the basic knowledge required to manage drinking water, wastewater and solid waste systems.

The Division of Compliance Assistance offers free compliance assistance. Our services are available to all individuals, communities and businesses regulated by the Kentucky Department for Environmental Protection. We want to help you succeed!

Hotline and Website for regulatory, technical or operational concerns  
800-926-8111  
[dca.ky.gov](http://dca.ky.gov)

Other programs administered by the Division of Compliance Assistance:

Kentucky Excel Program  
Kentucky Brownfield Program  
Kentucky Environmental Compliance Assistance Program

### ***Disclaimer***

*All reasonable precautions have been taken in the preparation of this document, including both technical and non-technical proofing. The Kentucky Division of Compliance Assistance and all staff assume no responsibility for any errors or omissions. Should the summarized information in this document be inconsistent with a governing rule or statute, the language of the rule or statute shall prevail. Reference herein to any specific commercial products, process, or service by trade name, trademark, manufacturer, or otherwise, does not necessarily constitute or imply its endorsement, recommendation, or favoring by the Kentucky Division of Compliance Assistance.*

## **SURFACE WATER TREATMENT OPERATOR CERTIFICATION COURSE**

Chapter 1: THE SURFACE WATER TREATMENT PLANT OPERATOR.....	5
Chapter 2: WATER SOURCES.....	19
Chapter 3: WATER CHARACTERISTICS and CHEMISTRY .....	26
Chapter 4: COAGULATION .....	49
Chapter 5: FLOCCULATION.....	69
Chapter 6: SEDIMENTATION .....	79
Chapter 7: ALTERNATIVE TREATMENT PROCESSES .....	96
Chapter 8: FILTRATION.....	127
Chapter 9: DISINFECTION.....	178
Chapter 10: BACTERIOLOGICAL MONITORING .....	213
Chapter 11: IRON AND MANGANESE.....	220
Chapter 12: TASTE and ODOR CONTROL .....	227
Chapter 13: FLUORIDATION .....	237
Chapter 14: STABILIZATION .....	243
Chapter 15: CROSS CONNECTIONS .....	251
GLOSSARY.....	273
APPENDIX .....	295
REFERENCES.....	311

This page left blank intentionally.

# Chapter 1: THE SURFACE WATER TREATMENT PLANT OPERATOR



## Chapter 1 Objectives

1. Explain when and why operator certification came into existence.
2. Determine what constitutes a public water system.
3. Understand and be able to notate the size parameters relative to certification classifications of treatment facilities.
4. Recall the number of continuing education hours necessary to renew operator certifications.
5. Remember the grace period and monetary penalty of failing to renew operator certification on time.
6. Delineate the newly more regulated entities that have an impact on the Gulf of Mexico zone of hypoxia.
7. Explain the notions of professionalism and ethical behavior.

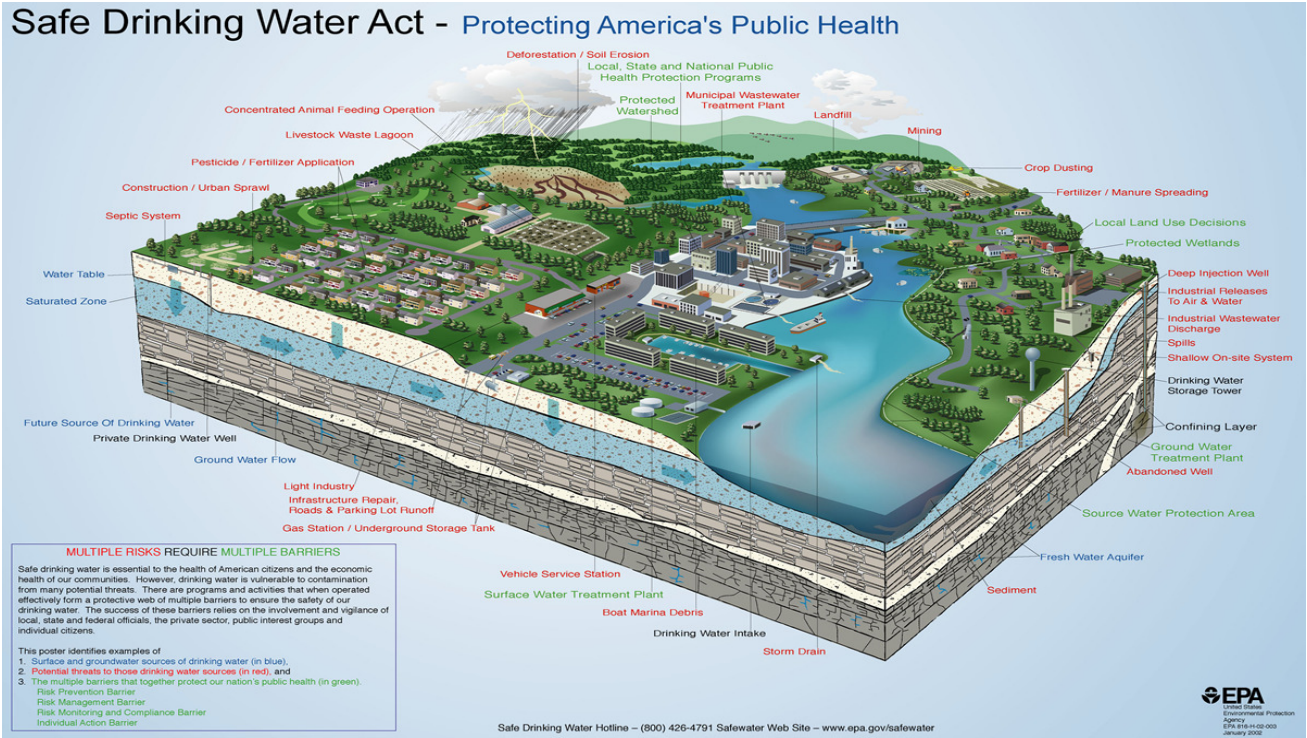

## History

When the Cuyahoga River in Cleveland Ohio caught fire for the fifth time on June 22, 1969, people began complaining about the abysmal condition of the waters in the United States. Publicity from this event was a major impetus for the passage of the Clean Water Act (CWA) in 1972. This statute employs a variety of regulatory and nonregulatory tools to sharply reduce direct pollutant discharges into waterways, finance municipal wastewater treatment facilities, and manage polluted runoff.

The CWA was followed up by the Safe Drinking Water Act (SDWA) in 1974 in order to protect the quality of both actual and potential drinking water in the United States. This statute requires the United States Environmental Protection Agency (USEPA) to regulate all “public water systems”. This regulation included Maximum Contaminant Levels (MCL) and Maximum Contaminant Level Goals (MCLG) for each regulated contaminant. The SDWA was amended in 1986 to address, among other things, the regulation of lead levels in solder and flux and defined “lead free” pipes. In 1996 the act was further amended to emphasize sound science and risk-based standard setting, small water supply system flexibility and technical assistance, community empowered source water assessment and protection, public right-to-know, and water system infrastructure assistance through a state revolving loan fund (SRF). Further revisions to the SDWA in 1996 included:

Consumer Confidence Reports (CCR) that all community water systems must distribute annually about the water they provide, including information on detected contaminants, possible health effects, and the water's source;

Cost-Benefit Analysis which mandates that the EPA conduct a thorough cost-benefit analysis for every new standard to determine whether the benefits of a drinking water standard justify the costs associated with them;

Drinking Water State Revolving Funds (SRF) which states can use to help water systems make infrastructure or management improvements or to help systems assess and protect their source water;

Microbial Contaminants and Disinfection Byproducts (DBP) which required the EPA to strengthen protection for microbial contaminants, including cryptosporidium, while strengthening control over the byproducts of chemical disinfection.

Operator Certification where water system operators must be certified to ensure that systems are operated safely. In 1999 the EPA issued guidelines specifying minimum standards for the certification and recertification of the operators of community and non-transient, noncommunity water systems. All states are currently implementing EPA-approved operator certification programs.

Public Information and Consultation: The SDWA emphasizes that consumers have a right to know what is in their drinking water, where it comes from, how it is treated, and how to help protect it and established its Drinking Water Hotline among other resources.

Small water systems are given special consideration and resources under the SDWA, to make sure they have the managerial, financial, and technical ability to comply with drinking water standards.

Public water systems (PWS) are defined by the EPA as "a system for the provision to the public of water for human consumption through pipes or other constructed conveyances, if such a system has at least fifteen service connections or regularly serves at least twenty-five individuals.

***Why should I become a certified operator?***

Wastewater and drinking water system operators are front-line environmental professionals who ensure the quality of Kentucky's water resources and protect the public's health. Only operators that are certified by the Kentucky Certification and Licensing Branch can be in responsible charge of a wastewater or drinking water system.

Working in the water and wastewater industry can be extremely rewarding as you will be providing a critical service to your community. It just might be one of the most important positions in the world since no one can live without water. It takes knowledgeable, conscientious people to deliver clean, potable water and to ensure that wastewater is treated and returned as clean water to the environment.

***Certification Process***

Certification is obtained by meeting minimum education and experience requirements, submitting the appropriate forms and fee and by passing the certification examination with at least a 70%. Regulations pertaining to the certification of drinking water and wastewater system operators are located in [401 KAR Chapter 11](#).

***System Classifications***

A Subclass "A" system is a system that treats: Surface water or groundwater under the direct influence of surface water; or Groundwater not under direct influence of surface water that uses gravity filtration.	
Class I-AD	Water treatment plant with a design capacity < 50,000
Class II-A	Water treatment plant with a design capacity ≥ 50,000 but < 500,000
Class III-A	Water treatment plant with a design capacity ≥ 500,000 but < 3,000,000
Class IV-A	Water treatment plant with a design capacity ≥ 3,000,000



***Regulatory Education and Experience***

Class I-AD	High School Diploma or GED <u>and</u> One (1) year of acceptable operation of a Subclass A public water system with any design capacity shall be required.
Class II-A	High School Diploma or GED <u>and</u> Two (2) years of acceptable operation of a water treatment plant with Six (6) months in a Class IIA, IIIA or IVA water treatment plant shall be required.
Class III-A	High School Diploma or GED <u>and</u> Three (3) years of acceptable operation of a water treatment plant with One (1) year of that experience in a Class IIA, IIIA or IVA water treatment plant shall be required.
Class IV-A	Baccalaureate degree in engineering, science or equivalent is required and One (1) year of acceptable operation of a Class IIIA or IVA public water treatment plant shall be required.

***Operators in Training (OIT) Certifications***

Operators in training certifications are available for each certification type. An individual can apply for an OIT license that is one level higher and of the same type as the certification that the individual currently holds. An individual may also apply for an entry level OIT certification. OITs must pass the appropriate operator certification exam and work under the responsible charge of a mentor. To apply for the exam, individuals must submit the following to the Certification and Licensing Branch:

- Education and Experience Documentation Form;
- Registration Form for Exams and Training;
- The appropriate fee; and
- A letter from the applicant’s mentor. The letter from the mentor must include:
  - A commitment to oversee the applicant’s work after the applicant becomes an OIT;
  - A commitment to mentor the applicant as long as the applicant is under the mentor’s direct responsible charge;
  - Verification that the mentor is not currently mentoring any other OITs; and
  - Confirmation that the mentor holds a certification license that is equal to or greater than the certification level required to serve in primary responsibility of the facility where the mentor and prospective OIT works.

Wastewater Treatment Class I-OIT who operates a wastewater treatment plant owned by the operator that serves only one residence may have primary responsibility for

that plant. All other OITs may not be in responsible charge of a facility unless they hold an additional certification license that does not have an OIT designation.

### ***Certification Renewal or Maintenance***

Drinking water treatment, distribution and bottled water system certifications expire on June 30 of even-numbered years. Certifications shall remain valid until the expiration date, unless suspended, revoked or replaced by a higher classification certificate before that date. Certificates issued between Jan. 1 and June 30 of a renewal year will be issued to include the next two-year renewal period. Failure to renew before July 1 of the renewal year will result in the expiration of certification and a late fee assessment. The certificate shall terminate if not renewed on or before December 31 of the year the certification expired. Certified operators with expired certificates shall not be in responsible charge of a drinking water or wastewater facility.

Certified operators (excluding OIT certificates) may renew their license(s) electronically through the cabinet Web site using the [E-Search](#) link or by submitting the Application for Certification Renewal and the appropriate fee to the Division of Compliance Assistance, Certification and Licensing Branch, 300 Fair Oaks Lane, Frankfort, KY 40601.

Certified operators who are designated an Operator in Training may renew a certification without examination if the operator has:

- Satisfied the continuing education requirements;
- Earned the required years of operational experience;
- Submitted an Education and Experience Documentation form verifying his or her experience;
- Submitted a letter of recommendation from a mentor; and
- Submitted a completed Application for Certification Renewal form and the renewal fee to the cabinet or has renewed the certification electronically on the cabinet's Web site.
- 

Drinking water treatment, distribution and bottled water certified operators training hours shall be completed for each renewal during the two (2) year period immediately prior to the certificate expiration date. Certified operators holding a treatment, distribution and/or bottled water certificate shall complete the required number of cabinet-approved training hours for the highest certificate held in lieu of completing the required number of continuing education hours required for both certificates.

***Reminder -- Continuing education hours earned prior to certification shall not count toward certificate renewal.***

### ***Operator Ethics – Standards of Professional Conduct for Certified Operators***

In order to safeguard the life, health, and welfare of the public and the environment and to establish and maintain a high standard of integrity in the certified operator profession, standards of professional conduct apply to persons certified in accordance with 401 KAR Chapter 11. These standards state:

- (a) A certified operator shall, during the performance of operational duties, protect the safety, health, and welfare of the public and the environment;
- (b) A certified operator shall use reasonable care and judgment in the performance of operational duties;
- (c) If a certified operator's judgment is overruled by an employer under circumstances in which the safety, health, and welfare of the public or the environment are endangered, the certified operator shall inform the employer of the possible consequences;
- (d) A certified operator shall be objective, truthful, and complete in applications, reports, statements, and testimony provided to the cabinet; and
- (e) A certified operator shall ensure the integrity of the samples that the operator collects, prepares, or analyzes so that results shall be a true representation of water quality.

The full set of standards is located in 401 KAR 11:020.

Certified operators who violate the standards in 401 KAR 11:020 are subject to disciplinary actions which include but are not limited to:

- (a) Probation of the operator's certification for a specified period of time, not to exceed one (1) year;
- (b) Suspension of the operator's certification for a specified period of time, not to exceed four (4) years, during which the certification shall be considered void;
- (c) Revocation of the operator's certification;
- (d) Civil or criminal penalties; or
- (e) A combination of the disciplinary actions listed above.

Disciplinary actions are outlined in 401 KAR 11:050, Section 4.

*All regulations related to the certification of wastewater and drinking water operators are located in 401 KAR Chapter 11. A copy of the regulations is located in this manual and it is*

*recommended that you become familiar with the regulations that govern your profession.*

### ***Professionalism***

Professionalism is the skill, competence, or character expected of a member of a highly trained profession; and the use of professionals instead of amateurs.

We are in a low visibility PROFESSION and our customers don't know how important our work is to their well being.

We operators need to regard our profession as a PROFESSION, not just a job, and take our cues from other professionals.

Be proud of your profession. You, as an operator, provide one of the resources that human beings need to survive.

The purpose of treatment is to provide POTABLE WATER fit for human consumption to our customers.

**KNOWLEDGE + YOUR DILIGENCE = POTABLE WATER**

**SOURCE WATER QUALITY + TREATMENT = FINISHED WATER QUALITY**

**Monitor Closely    Controlled Change    Set Goals**

This formula for treating water is true and accurate for all systems.

**SOURCE WATER + FACILITIES = TREATMENT TECHNIQUE**

Since source waters are so different, treatment facilities and techniques will be different as well. For this reason there is no "one size fits all" or quick fix that will work for all source waters or facilities. What works at one treatment facility will not necessarily work at another. Furthermore, what works at your facility today may not work nearly as well tomorrow when the source water changes.

**The focus of operation should be:**

- Set finished water goals
- Monitor closely all affective raw water quality changes
- Understand the operational theory and design characteristics of your facility.
- Monitor and evaluate all factors that affect each treatment process.

- Take into account the big picture; recognize the interaction between processes.
- Measure and evaluate the results of all changes.
- Continuously strive to improve yourself as an operator.

***“You can’t build a reputation on what you are going to do.”***

– Henry Ford



## *List of Key Acronyms*

AWWA	American Water Works Association
AwwaRF	American Water Works Research Foundation
BAC	Biologically active carbon
BAT	Best available treatment
BMP	Best Management Practice
CPE	Comprehensive Performance Evaluation
CTAP	Kentucky DOW Comprehensive Technical Assistance Program
DBP	Disinfection By - Product
D/DBP	Disinfectant and Disinfection by – Product
D/DBPR	Disinfectant and Disinfection by – Product Rule
DOW	Division of Water (Kentucky)
ES	Effective size
ESWTR	Enhanced Surface Water Treatment Rule
GWR	Ground Water Rule
IESWTR	Interim Enhanced Surface Water treatment Rule
IFE	Individual filter effluents
LCR	Lead and Copper Rule
LTESWTR	Long Term Enhanced Surface Water Treatment Rule
LT2	Long Term 2 (Enhanced Surface Water Treatment Rule)
MIEX	Magnetic resin (trademark acronym for a resin specific for DOC removal)
MIOX	Mixed oxidants
MOR	Monthly operating report
MRDL	Maximum residual disinfectant level
NOM	Natural organic matter
NPDES	National Pollutant Discharge Elimination System
O & M	Operations and management
ORP	Oxidation reduction potential
PWS	Public water system
QA	Quality assurance
QC	Quality control
RCAP	Rural Community Assistance Partnership
RTCR	Revised Total Coliform Rule
SCADA	Supervisory Control and Data Acquisition
SG	Specific gravity
SUVA	Specific ultraviolet absorbance
SWTR	Surface Water Treatment Rule
TC	Total coliform
TCR	Total Coliform Rule

SURFACE WATER TREATMENT OPERATOR CERTIFICATION

---

TOC	Total organic carbon
UC	Uniformity coefficient
USEPA	United States Environmental Protection Agency
USGS	United States Geological Survey
WTP	Water Treatment Plant
WHPA	Well Head Protection Area

***Review Questions for Chapter 1 – The Surface Water Treatment Plant Operator***

1. When was the SDWA enacted? Identify when the SDWA was enacted.
2. When was operator certification federally mandated? Identify when the operator certification process was federally mandated.
3. An operator has how many months to renew their license without having to retest? Explain how long operators have to review their license before having to retest.
4. What is an operator bound by regulation to do if they are told to do something illegal?



***Answers to Review Questions for Chapter 1 - The Surface Water Treatment Plant Operator***

1. 1974
2. 1996
3. 6 months
4. Inform whoever gave the order of the consequences.

This page left blank intentionally.

# Chapter 2: WATER SOURCES

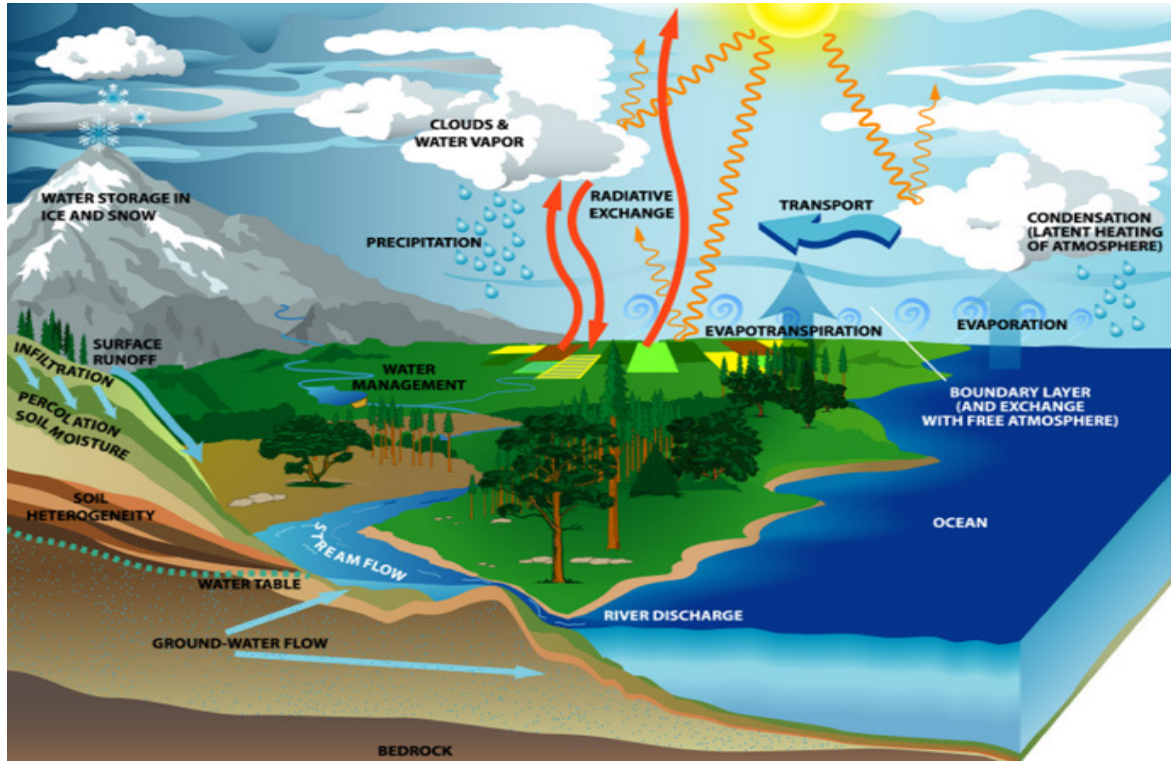

## The Hydrologic Cycle

### Chapter 2 Objectives

1. Define the hydrologic cycle and be able to recall the movements of water that are entailed within.
2. Delineate the three types of source water and the differences between them.
3. Determine what entities make up the EPA "Multiple Barrier Approach" to water quality.
4. Be able to differentiate between types of aquifers.
5. Determine which type of source water is the easiest to remediate.
6. Explain what significance stratification has to raw water.

## *The Hydrologic Cycle*

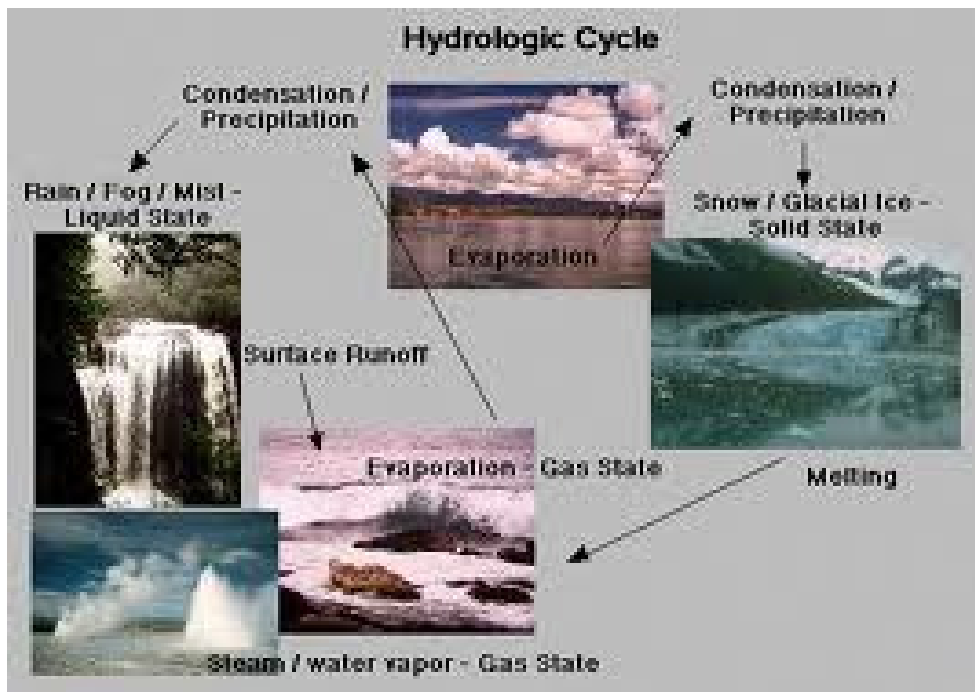

**Evaporation** – A process in which something is changed from a liquid to a vapor without its temperature reaching the boiling point.

**Precipitation** – The formation of rain, snow, hail etc. from moisture in the air.

**Runoff** – Water, sometimes carrying agricultural or industrial wastes, that is carried by rainfall and melting snow into surface waters.

**Infiltration** - Water passing through the soil and recharging aquifers.

**Percolation** – Making a liquid pass through a filter (soil and rock) or porous substance.

**Transpiration** – A process where water vapor is given off to the atmosphere by a plant's surface ( leaves, exposed roots etc.).

Current federal drinking water regulations define **three distinct and separate sources of water**: 1) surface water, 2) groundwater under the direct influence of surface water, and 3) groundwater.

### ***Surface Water***

Surface water is water that is open to the atmosphere and results in overland flow. Much of this water is the result of surface runoff. Specific sources of supply include rivers, lakes, streams, springs, shallow wells and man-made impoundments.

Surface waters are easily polluted (or contaminated) with harmful chemicals and pathogenic microorganisms that cause diseases in humans. These harmful entities can enter surface water sources from runoff and upstream discharges.

The **turbidity** of surface water often fluctuates relative to the amount of precipitation that can increase treatment requirements, costs, and the need of operator diligence.

The **temperature** of surface water vacillates with the ambient temperature. This fluctuation in temperature impacts all chemical and physical treatment processes and makes consistent water quality more difficult to achieve.

Decomposing plant and animal life (organics) are prevalent in surface water. Organics can affect the taste, odor and color of water and these organics have shown themselves to be precursors of disinfection by products. Organics can also accelerate corrosion rates and greatly increases treatment requirements and associated costs.

Water quality problems such as hardness, or iron and manganese discoloration as a result of dissolved minerals occur infrequently in surface water supplies but can occasionally be problematic with some waters.

Surface water sources are easier to access, pollute, and remediate than groundwater and quantity can be unstable during droughts.



Because surface water supplies are so susceptible to pollution and pathogenic contamination, higher levels of treatment that will include **coagulation, flocculation, and filtration** will likely be necessary. These processes are a part of the EPA **multiple barrier concept of water treatment**.

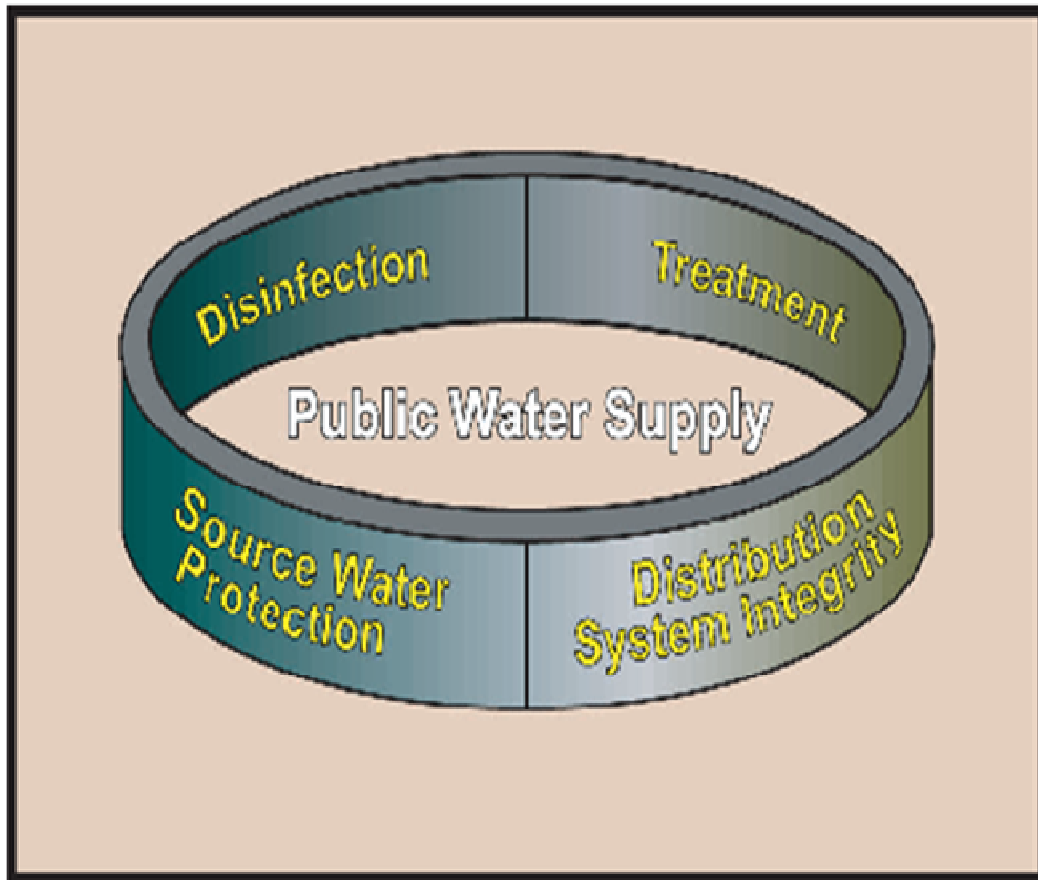

4.3 Figure 1: Multiple barrier concept

**Source Water Protection** – Protecting the water before it gets to the treatment facility means less time and money to treat it when it gets to the plant.

**Distribution** – Provide both the quantity and quality of water to our customers.

**Treatment** – Remove potentially harmful chemicals and aesthetically displeasing contaminants

### ***Groundwater under the direct influence of surface water***

Groundwaters under the direct influence (GWUDI) are affected by the same parameters as surface water so the levels of treatment are much the same as surface water.

### ***Groundwater***

Groundwater is considered to be water that is below the earth's crust, which has been stored within an aquifer, and does not change in character relative to precipitation events. An aquifer is an underground layer of water-bearing material. Groundwater is usually brought to the surface by a well.

Because of the earth's abilities to filter water as it travels down to the aquifer, the water quality of groundwater is generally good. Because of its lack of exposure to the atmosphere, contamination issues are usually much less than surface water. Because of its characteristics and the lack of outside influences, groundwater usually requires less treatment than surface water.

WELL WATER - NATURALLY BETTER

**You can't always see your drinking water, but it's there.**

Water—our most precious natural resource. Natural reservoirs of ground water found below our earth's surface provide well owners with quality drinking water. Tap into nature's hidden resource with a well.

**WATER SYSTEMS COUNCIL**

FOR INFORMATION ON WELLS, CALL TOLL FREE 888-395-1033

***Review Questions for Chapter 2 – Water Sources***

1. What are the six hydrologic cycle processes that transport water around our planet?
2. An underground layer of water bearing material is called what?
3. Which source water, ground or surface, is easier to remediate?



***Answers to Review Questions for Chapter 2 – Water Sources***

1. Evaporation, condensation, runoff, infiltration, precipitation, transpiration
2. An aquifer
3. Surface

This page left blank intentionally.

# Chapter 3: WATER CHARACTERISTICS and CHEMISTRY

## Chapter 3 Objectives

1. Define a MCL, a MCLG and associated action levels
2. Define an inorganic contaminant and what differentiates them from organic contaminants and explain what role both play in drinking water treatment.
3. Define pH, and explain its significance in water treatment, how it is measured and the effects of the differences in measurements, and how to alter or change pH levels.
4. Define alkalinity and what role it plays in water treatment as well as ways to change alkalinity levels
5. Determine how temperature variances could impact both the water being treated and the treatment processes and how to adapt to such changes.
6. Explain how a treatment facility can adapt to significant temperature change.
7. Define turbidity and explain its significance in the treatment process as well as how it is measured.
8. Define hardness.
9. Delineate the types of color and their potential impact on the treatment process, disinfection byproducts and customer's perceptions of their water.
10. List the most predominate causes of taste and odor in drinking water, how it relates to TOC, NOM, and DOC.
11. Define TDS and its impact on the treatment process.
12. Explain the importance of intake structures to the treatment process, which intake level would be superior and the means available to instigate inexpensive solutions to intake issues.

## ***Water Characteristics and Chemistry***

One of the first things a water treatment operator should learn is where the water entering their plant comes from. Your water source affects both the quantity and quality of the raw water to be treated. A basic understanding how your raw water acquires its characteristics and how these characteristics will affect human health and necessary treatment techniques will help you effectively treat your water.

Potable water is water that is safe for drinking purposes from the standpoint of its chemical, physical, and biological characteristics. Public water systems (PWS) product (potable water), must meet certain federal and state water quality standards enforced by the USEPA and the Kentucky Division of Water (DOW).

Before any system in Kentucky begins offering water for human consumption it first must perform a series of tests on its raw water source(s) to determine 1) what type of contaminants are present in the raw water 2) how pervasive are these contaminants 3) what is the likelihood of the numbers of these contaminants changing over time. This information is then used to determine what treatment processes are required, CT calculations, monitoring frequencies, and design parameters for plant expansions or for new treatment facilities.

Periodically, water systems undergo sanitary surveys. Sanitary surveys evaluate source water characteristics, treatment process effectiveness, distribution system efficiencies, certified operator availabilities, and capacity development guidelines.

Basic knowledge of water quality, characteristics, and treatment processes are necessary to competently perform the duties of a certified treatment operator. After gaining this knowledge, using it on a regular basis will hone your skills and improve your performance as well as the performance of the plant.



### ***Maximum Contaminant Levels***

Maximum Contaminant Levels (MCLs) are

PRIMARY MCL's		SECONDARY MCL's	
<b>NITRATE</b>	10.0 mg/L	<b>SULFATE</b>	250 mg/L
<b>FLUORIDE</b>	4.0 mg/L	<b>FLUORIDE</b>	2.0 mg/L
<b>LEAD</b>	0.05 mg/L *	<b>IRON</b>	0.3 mg/L
<b>COPPER</b>	1.3 mg/L **	<b>MANGANESE</b>	0.05 mg/L
<b>TURBIDITY</b>	0.3 NTU ***		

\* Action Level 0.015 mg/L

\*\* Action Level 1.3 mg/L

\*\*\* As an average of monthly samples

When MCL's are exceeded, the consuming public **MUST** be informed as dictated by the Public Notification Rule and Consumer Confidence reporting.

**MAXIMUM CONTAMINANT LEVEL GOALS (MCLG)** represents the level of a contaminant that would pose no detrimental health effect to humans. It is often less than the MCL for that individual contaminant. As technology and/or compliance treatment costs improve, the MCL will gradually be lowered by the EPA until it equals the MCLG.

**TREATMENT TECHNIQUES** – Some recent regulatory additions and changes necessitate the implementation of new or different treatment techniques for the removal of certain contaminants in drinking water. Some of these treatment challenges are as follows:

- **CT for Giardia** (3-log removal), viruses (4-log removal), and cryptosporidium (up to 6-log removal)
- **TOC** percent removal requirement based on upon raw water TOC and alkalinity levels.
- **DBP's** flushing and cleaning requirements for distribution systems.
- **Lead and Copper** removal and public notification requirements whenever action levels are exceeded.

There are different techniques and methods used to treat the contaminants in water. The type of treatment used is dependent on monetary considerations, source water quality, and engineering recommendations. Choosing the proper application requires diligence.

<b>Water Quality Problem</b>	<b>Treatment</b>
<b>1. Coliforms or microbiological contamination</b>	1a. disinfection (chlorination) 1b. disinfection (other oxidants – ozone, chlorine dioxide, chloramination) 1c. coagulation, flocculation, sedimentation, filtration & disinfection
<b>2. Turbidity</b>	2. coagulation, flocculation, sedimentation & filtration
<b>3. Odors</b>	3a. clarification (coagulation, flocculation, sedimentation & filtration) 3b. oxidation (chlorination or permanganate) 3c. special oxidation (chlorine dioxide) 3d. adsorption (GAC or PAC) 3e. aeration
<b>4. Iron and/or manganese</b>	4a. sequestration (poly or ortho phosphates) 4b. removal by special ion exchange 4c. permanganate and greensand 4d. oxidation by aeration* 4e. oxidation with chlorine* 4f. oxidation with permanganate *filtration must follow oxidation
<b>5. excessive hardness</b>	5a. ion exchange softening 5b. lime (and soda) softening
<b>6. dissolved minerals (high total dissolved solids)</b>	6a. ion exchange 6b. reverse osmosis
<b>7. corrosivity</b>	7a. pH adjustment with chemicals 7b. corrosion inhibitor addition (zinc phosphate, silicate)
<b>8. preventative treatment</b> <b>a. fluoridation</b> <b>b. trihalomethanes (THM's)</b>	8a. add fluoride chemicals 8b. (1) do not prechlorinate, disinfect with ozone, chlorine dioxide, or chloramines 8b. (2) remove THM precursors 8b. (3) remove THM's after they form

### ***Inorganics***

Non-life forms such as sand, clay, silt, salts and metals comprise the majority of the inorganics we see in the treatment plant. In addition there are some man-made chemical compounds developed from non-life materials that appear from time to time in our source water as a result of the erosion and dissolving of minerals or as by-products of industrial processes and pollution.

Some of the more common inorganic contaminants are lead, copper, barium, cadmium, nitrates, and arsenic and all of these are toxic to humans. Treatment for inorganic substances usually involves a combination of processes and is dependent upon which inorganic contaminant needs to be removed. Some of the more commonly used processes for inorganic removal include oxidation, coagulation combined with settling and filtration, carbon adsorption, lime softening, ion exchange, reverse osmosis, stabilization, and chlorine and UV disinfection.

A very prevalent drinking water problem relative to inorganics are the presence of iron or manganese, calcium or magnesium hardness and total dissolved solids (TDS).



**Without proper restoration, mining can have severe impacts upon stream hydrology, morphology, biota and water quality.**

## Surface Water Characteristics and Monitoring Parameters

Some monitoring of surface source water is done frequently to better understand their significance and their bearing on the successful operation of the treatment facility.

Among them are:

**pH** actually describes the hydrogen ion concentration in a water sample. pH is measured on a scale from 0 to 14 with a reading of 7 being neutral. The pH meter measures the relative amount of hydrogen ions versus hydroxyl ions in a solution. The lower the pH value, the greater the proportion of hydrogen to hydroxyl ions in the solution and the more *acidic* the solution. As pH values rise on the scale, the relative amount of hydroxyl ions proportionate to hydrogen ions becomes larger and the solution becomes more *basic*. A pH measurement of 7.0 is considered neutral and represents the point on the scale where the amount of hydrogen and hydroxyl ions are equal. Each numerical change on the pH scale is actually indicative of a tenfold change in the hydrogen ion concentration. Frequently a change in pH indicates a change in water quality. Monitoring and understanding the effect pH has on treatment processes can significantly improve the optimization of these processes. The measurement of pH is established using a calibrated pH meter.

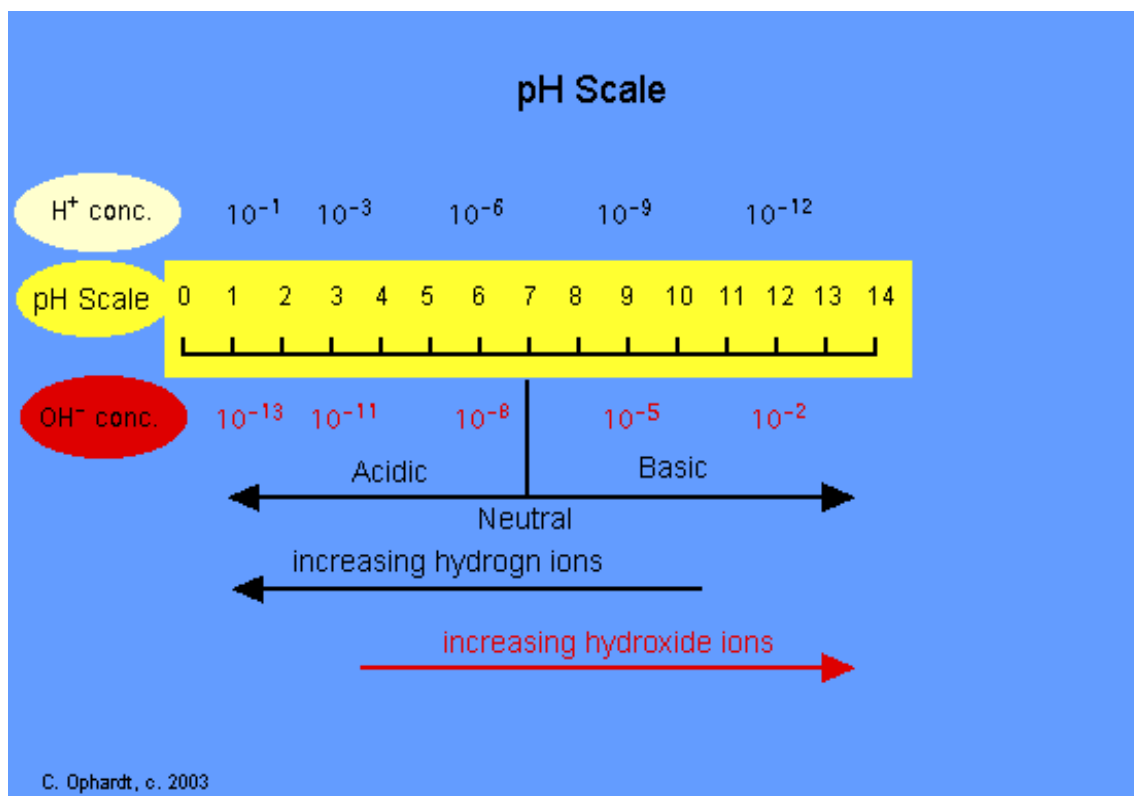



**Alkalinity** describes the ability of a substance to neutralize an acid. Alkalinity is a buffer to pH, which means that the higher the level of alkalinity is in a solution, the more acid it will take to lower the pH. Chemicals used to increase the alkalinity level in water (lime, caustic soda, soda ash etc.) have the effect of adding hydroxyl ions to a solution. When this addition of alkalinity creates an excess of hydroxyl ions in relation to hydrogen ions in the solution, the pH of the solution will increase accordingly. When acids are added to a solution (the addition of hydrogen ions) containing alkalinity, the hydrogen ions bind with the hydroxyl ions in solution (essentially forming water molecules) and reduce the alkalinity level in the solution without substantially affecting pH.

This is the buffering effect. As more acid is added to the solution the alkalinity will gradually be used up and the pH will then decrease accordingly. When more alkalinity is once more added to the water, it again creates an excess of hydroxyl ions and the pH will begin to rise dependent upon the amount of alkalinity added. Alkalinity is determined mathematically after observing a color change while titrating a weak acid into a solution.

**Temperature** is measured as degrees Fahrenheit or degrees Celsius. Temperature impacts every treatment process but it is the parameter of least control for an operator. Chemical reactions occur faster in warmer waters and particles settle out more quickly in warmer waters. Warmer waters are more conducive to the growth of organic substances and taste and odor issues are more noticeable in warmer temperatures. Temperature is measured by a thermometer. Sometimes it is necessary to convert temperatures in Fahrenheit to Celsius and vice versa.

$$^{\circ}\text{Fahrenheit} = (^{\circ}\text{Celsius} \times 1.8) + 32 \quad \text{Celsius} = (^{\circ}\text{Fahrenheit} - 32) \div 1.8$$

**Turbidity** is a measure of suspended matter in a water sample. It can be comprised of a myriad of entities including organic and inorganic substances. Turbidity can be a viable indicator of the amount of contamination or pollution in water, and as such turbidity levels should be minimized throughout the treatment process. Turbidity can also interfere with disinfection efforts by shielding pathogens from disinfection efforts.

**Simplified Diagram of  
a Pathogen Encapsulated  
by a Particulate**

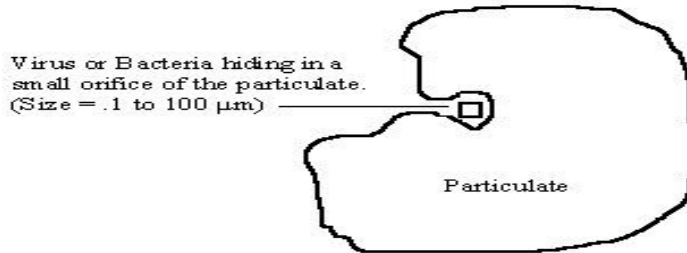
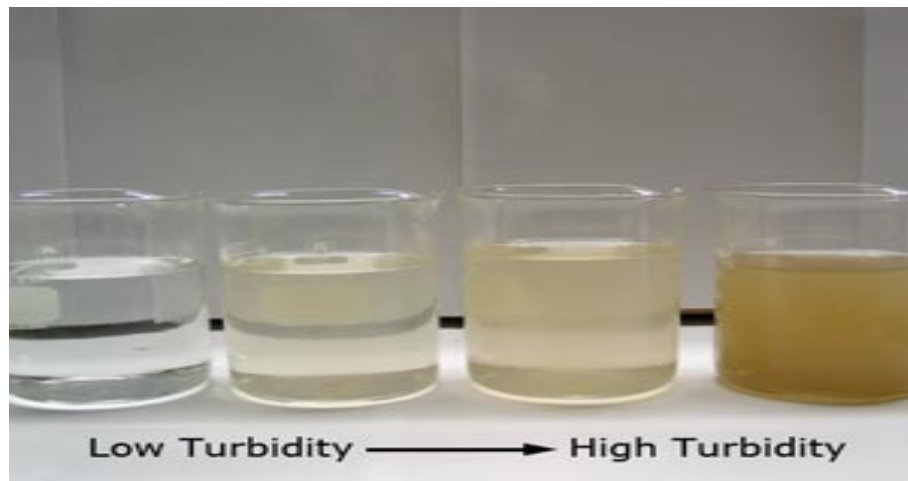

Figure 1 Courtesy of Eric Karch and David Loftis

Regulation requires water purveyors to achieve monthly average turbidity levels to be below 0.3 NTU measured in the combined filter effluent every four hours of plant operation. No treated water should ever exceed 1.0 NTU.

Settled water turbidity should be maintained below 1.0 NTU and finished water turbidity should be maintained below 0.1 NTU. Individual filters shall be continuously monitored and notated for performance and for inspection and maintenance. Measurement of turbidity is obtained using a calibrated and standardized turbidimeter.

Turbidimeters measure the reflective properties of the particulate in a sample. The results are shown as NTU's (nephelometric turbidity units). Different shaped and different colored particulate will produce varied results on the turbidimeter.



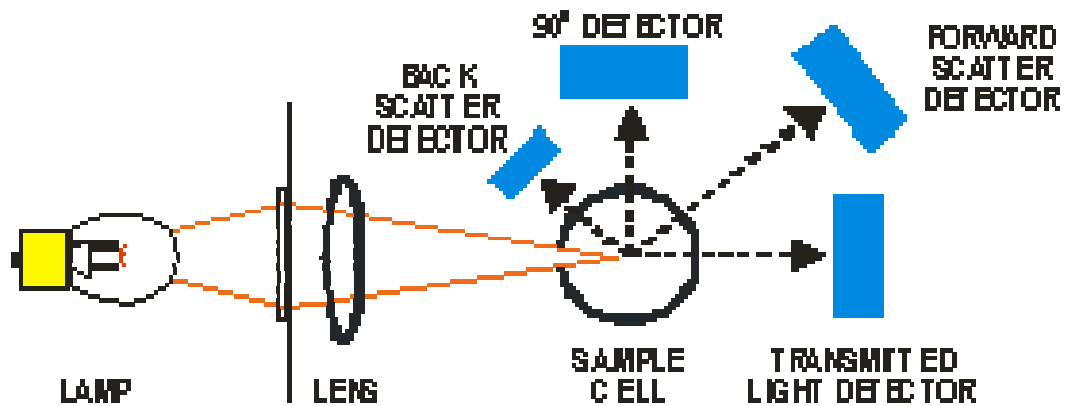
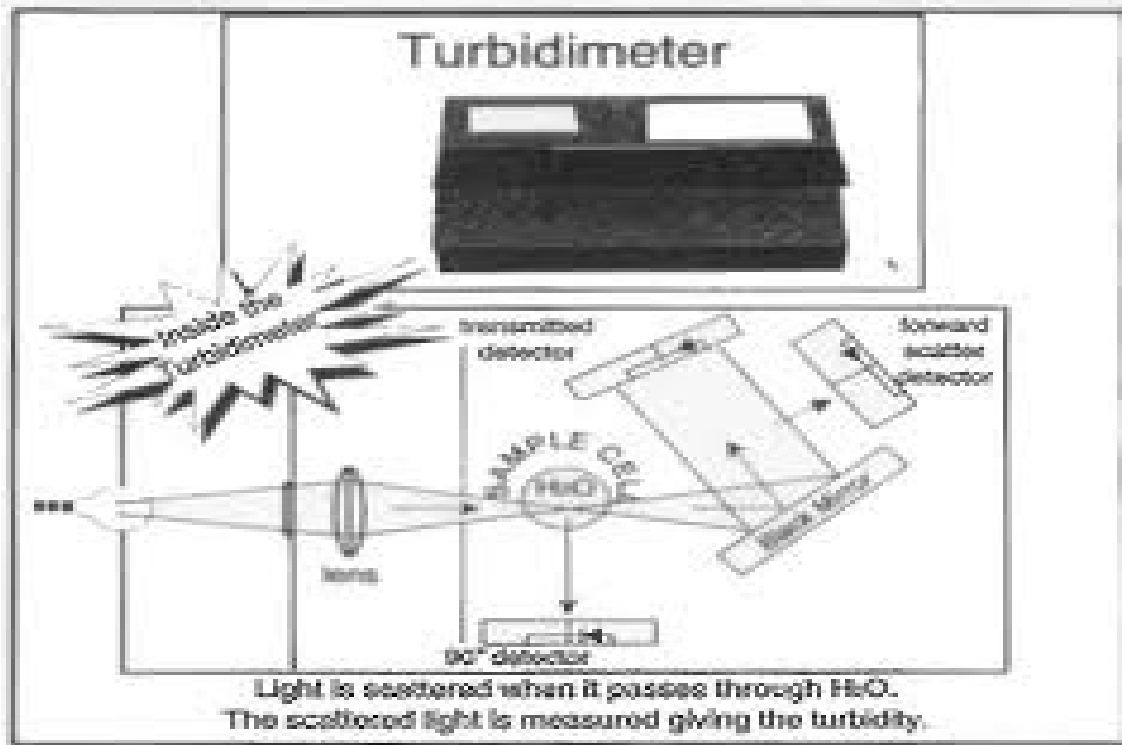

**Hardness** describes water containing a high level of calcium and magnesium ions. Excessive hardness in water causes soap to not lather, scale deposition on pipes, valves, meters, boilers, dishes, cookware and water heaters. Hardness can sometimes impart objectionable tastes to water as well as damaging some industrial processes. Softened water delivered to customers in Kentucky usually has a hardness level between 80 and 90 mg/L as calcium carbonate (CaCO<sub>3</sub>). Hardness levels are determined by titrating a weak acid into a solution while observing a color change.

**Color** relative to water is water that is aesthetically objectionable or it can be any water not deemed to be clear. There are **two types** of color:

- **True color**

- True color is caused by decomposing organic materials in the water.
- Since true color is composed of organics, these may aid in the formation of disinfection by products (DBP's) as well as biofilms and biological regrowth in distribution systems.
- Measured in color units (CU) by using a spectrophotometer.

- **Apparent color**

- Apparent color is caused by precipitated inorganics; frequently iron (Fe) and manganese (Mn) in the water.
- This type of color produces discoloration in the water as well as staining basins, tubs and laundry. Iron at levels greater than (>)0.3 mg/L causes red water and manganese greater than (>) 0.05 frequently causes black water.
- Apparent color is measured in mg/L using a spectrophotometer or a reagent method.

**Taste and odor** is aesthetically objectionable water that possesses any taste and odor outside of what the customer is used to. These issues can be caused by many major influences such as algae, reservoir stratification, decaying organics, wastewater, industrial wastes, minerals, dissolved gasses, incompatible chemical combinations and last but certainly not least treatment plant and distribution system shortcomings. Measurement is done by using the Threshold Odor Number

(TON method) where samples are diluted and arranged in order for detection by a panel of human observers. Average level of detection is used to describe the sample.

**Total Organic Carbon (TOC)** describes the organic composition of a water sample. TOC's are precursors to disinfection-by-product (DBP) formation. The most effective traditional removal of TOC is accomplished by enhanced coagulation, which is coagulation at a low pH. Activated carbon adsorption is also an effective method of removal. Regulatory removal requirements are based on raw water levels and alkalinity levels. Due to the costs associated with TOC analysis, samples are generally sent to an approved laboratory. Dissolved Organic Carbon (DOC) may be used as a surrogate to for TOC for in-plant process control and levels can be determined by a spectrophotometer using the UV – 254 method.

**Volatile Organic Carbon (VOC)** describes the major classes of contaminants include volatile organic compounds (VOCs), synthetic organic compounds (SOCs), inorganic compounds (IOCs), radionuclides, and microbial organisms (including bacteria). They can pose health problems including damage to the reproductive system, liver, nervous system and other organs. Common VOCs come from household products through septic systems, gasoline compounds (such as MTBE and benzene) and industrial solvents. Current regulatory procedures establish MCLs, MCLGs, and mandated treatment technologies based on ingestion of 2 liters per day. Water treatment operations subject to the SDWA must implement treatment and monitoring systems insure SDWA requirements are being met.

Your source water will frequently contain volatile organic compounds or chemicals (VOCs). Some of the more frequently encountered VOCs are: Benzene, Toluene, Formaldehyde, Xylene, Chloride, Ethylene glycol, Fuel Oil, vehicle exhaust , and gasoline. Most VOCs are absorbable to some extent. More weakly adsorbing compounds can often be removed by air stripping.

**Synthetic Organic Carbons (SOC)** enter drinking water from pesticides and herbicides. Synthetic Organic Chemicals (compounds) (SOCs) are also commonly found in surface water. Some commonly found SOC's are: Adipate, Lindane, Atrazine, 2, 4-D, Toxaphene, Diquat, Weed-B-Gon, Scotts 4XD and Bladex B.

Some organics in drinking water are caused by the decay of naturally occurring vegetation. These decay compounds are called lignins or tannins. A much larger group of organic contaminants are the thousands of manmade organic chemicals that have been created in the last 50 years. The U.S. Environmental Protection Agency (EPA) regulates some of these contaminants as health risks in the Safe Drinking Water Act (SDWA). These manmade organic contaminants can be grouped into subcategories that are often more recognized (and more easily pronounced) than the more formal chemical name. These subcategories are given below, along with a few illustrations of specific contaminants in each subcategory.

1. Industrial solvents, such as trichloroethylene, carbon tetrachloride
2. Hydrocarbons, such as benzene, xylene, toluene
3. Pesticides such, as aldicarb and chlordane
4. Herbicides such, as alachor and silvex

Trihalomethanes are the byproducts of the chemical reaction between chlorine and the natural occurring organics in drinking water. These naturally occurring carbon compounds are not hazardous by themselves, but when combined with chlorine, produce byproduct reactants, which have a health concern.

## **TREATMENT OPTIONS**

There are three treatment methods that have been shown to be effective in removing organics from drinking water. They are aeration, adsorption using activated carbon, and oxidation.

### **Activated Carbon Treatment: Advantages and Disadvantages**

Activated carbon has an enormous surface area for the volume it displaces. One pound has the surface area of more than a football field. Activated carbon is a material that attracts many types of organic contaminants onto its surface. Once the carbon's removal capacity is used up, the carbon may be returned to the



manufacturer for rejuvenation (for very large users), or can be disposed of appropriately. Activated carbon can foster the growth of bacteria by concentrating the food the bacteria needs to live. A final concern with activated carbon is the possible release of contaminants already adsorbed. This is known as “dumping” and could occur when the carbon is nearly saturated with contaminants, and a contaminant of higher preference displaces another with lower adsorption preference.

### **Aeration: Advantages and Disadvantages**

Aeration treatment consists of passing large amounts of air through the contaminated water. The efficiency of the device is improved by breaking up the water flow into many small droplets. The goal is to maximize the water's surface area to allow the contaminants to volatilize into the air stream. Aerator configurations include packed tower and low profile bubble tray styles. Where aeration is used, two operational problems are possible:

Where there are elevated levels of iron or manganese, rusty staining of water use fixtures and clothing is possible.

Bacterial slime may grow in aerators requiring continuous or periodic chlorination.

The advantage of aeration is that there is no disposal of radioactivity waste or regeneration of the treatment system necessary.

### **Oxidation: Advantages and Disadvantages**

Certain organic contaminants will chemically react with oxygen and oxygen-like compounds. After this treatment is accomplished, the resultant compounds may be either fully neutralized or will have a lower level of hazard. Further treatment may still be necessary. Oxidizing chemicals include potassium permanganate, hydrogen peroxide, and hypochlorite.

The Safe Drinking Water Act (SDWA) of 1974 required the administrator of the USEPA to establish minimum national standards for controlling the presence of contaminants in drinking water. This means that any technology used to remove SOCs from drinking water must be at least as effective as GAC. The SDWA

amendments declare granular activated carbon (GAC) as the "best available control technology" (BAT) for removing synthetic organic chemicals (SOCs) from drinking water.

**Dissolved Oxygen (DO)** is the amount of oxygen dissolved in water and it can impact water treatment operators in a number of ways. The amount of oxygen water can support in its dissolved state is temperature dependent. Iron (Fe) and manganese (Mn) will exist in its reduced (colorless) form when dissolved oxygen levels are low or nonexistent. Colder water can hold more dissolved oxygen than warmer water. Dissolved oxygen levels at or near 100% saturation can release oxygen into filters in the winter and could be a cause of air binding of the filters. Low or zero dissolved oxygen levels at the bottom of lakes or reservoirs often cause taste and odor problems. The presence of dissolved oxygen in water can contribute to the rate of corrosion in piping systems. Dissolved oxygen levels can be determined with the use of a DO meter with values expressed in mg/L.

**Total Dissolved Solids (TDS)** are all the solids that are dissolved in water. In potable water, total dissolved solids consist mainly of inorganic salts, minute amounts of organic matter, and dissolved gases. Total dissolved solids can be reduced with oxidation/settling/filtration, and can be removed by distillation or membrane filtration. The higher the total dissolved solid concentration, the greater the likelihood of taste and odor issues as well as scale deposition on pipes and fixtures. The total dissolved solid concentration is measured on a sample of water that has passed through a fine mesh filter to remove the suspended solids.

The water that passes through the filter is evaporated and the remaining residue represents the total dissolved solid level. Generally, waters with a TDS content < 50 mg/L are the most desirable for domestic uses.

Surface water sources that are polluted by man and nature are likely to contain quite a variety of pollutants. Biological organisms such as bacteria, viruses, and protozoa as well as suspended and dissolved organic and inorganic materials are usually prevalent in surface water. By – products of land erosion and runoff, dissolved minerals, decomposed plant and animal materials, airborne contaminants, industrial discharges and the ever –present human and animal



waste continue to contaminate our surface water sources.

For conventional treatment purposes, particulate impurities can be divided **into two general classifications**:

- **Settable solids**: larger sized particles, such as sand and heavy silts that can be easily removed from water by slowing down the flow enough to allow natural gravity settling to occur.
- **Nonsettleable solids** (colloidal matter): smaller sized particles, such as fine clays and silts, bacteria, and organic residues which do not readily settle out and which require chemical treatment to produce larger particles that are settleable.

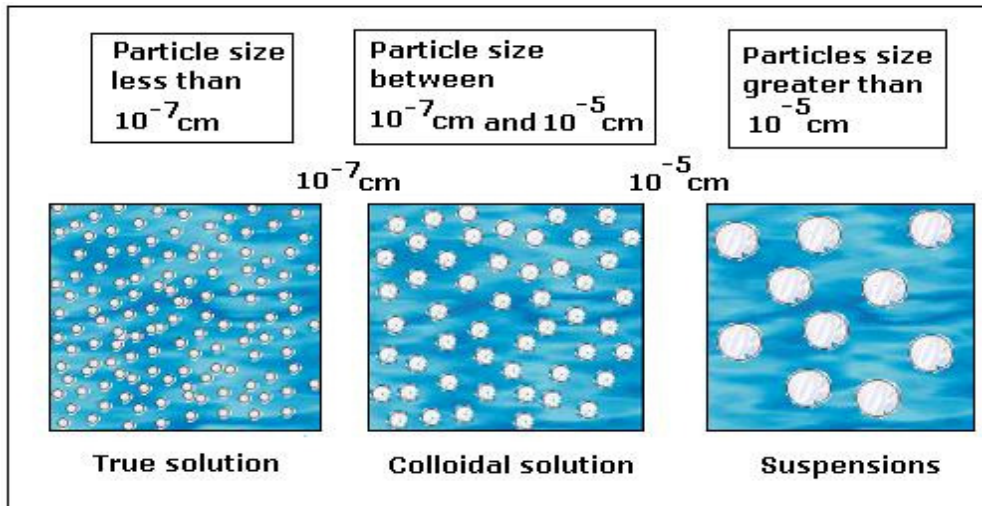

***If you, as an operator, don't know the characteristics of your raw water, how can you effectively treat it?***

- What contaminants are present?
- How prevalent are these contaminants?
- How frequently and how much will these parameters change?

**“Potable water” is water that is safe for human consumption and must meet certain federal and state water quality standards.**

### ***Public Health Protection Challenges***

- There is an increase in the frequency, intensity, and duration of extreme weather events ( droughts, rain events, icestorms, etc).
- Some pathogens are acquiring resistance to conventional disinfection.
  - 0.2 log or less of inactivation of Cryptosporidium with free chlorine at 5 – 15 mg/L for 60 – 240 minutes. (Finch, 1995)



- Meeting existing compliance levels is not always effective in preventing disease.

Cryptosporidium Outbreaks vs. Finished Water Turbidity			
Location of Outbreak	Year	General Plant Information	Turbidity Information
Las Vegas, Nevada (CDC, 1996)	1993-1994	No apparent deficiencies; SWTR compliant; performed chlorination, filtration (sand & anthracite)	Average raw 0.14 NTU 1/93-6/95 Maximum of 0.3 Reg 0.17 NTU
Milwaukee, Wisc. (CDC, 1996 Logsdon, 1996)	1993	SWTR compliant; deteriorated source quality & decreased coag/floc process effectiveness	Dramatic temporary finished turbidity, high of 2.7 NTU
Jackson County, Oregon (USEPA, 1997)	1992	Poor plant performance (excessive levels of algae & debris) no pre-chlorination	When outbreak occurred, filtered water averaged 1 NTU
Carrolton, Georgia (USEPA, 1997 Logsdon, 1996)	1987	Conventional filtration plant; sewage overflow into intake, filters placed into service without backwash	Filtered turbidity reached 3 NTU from one filter

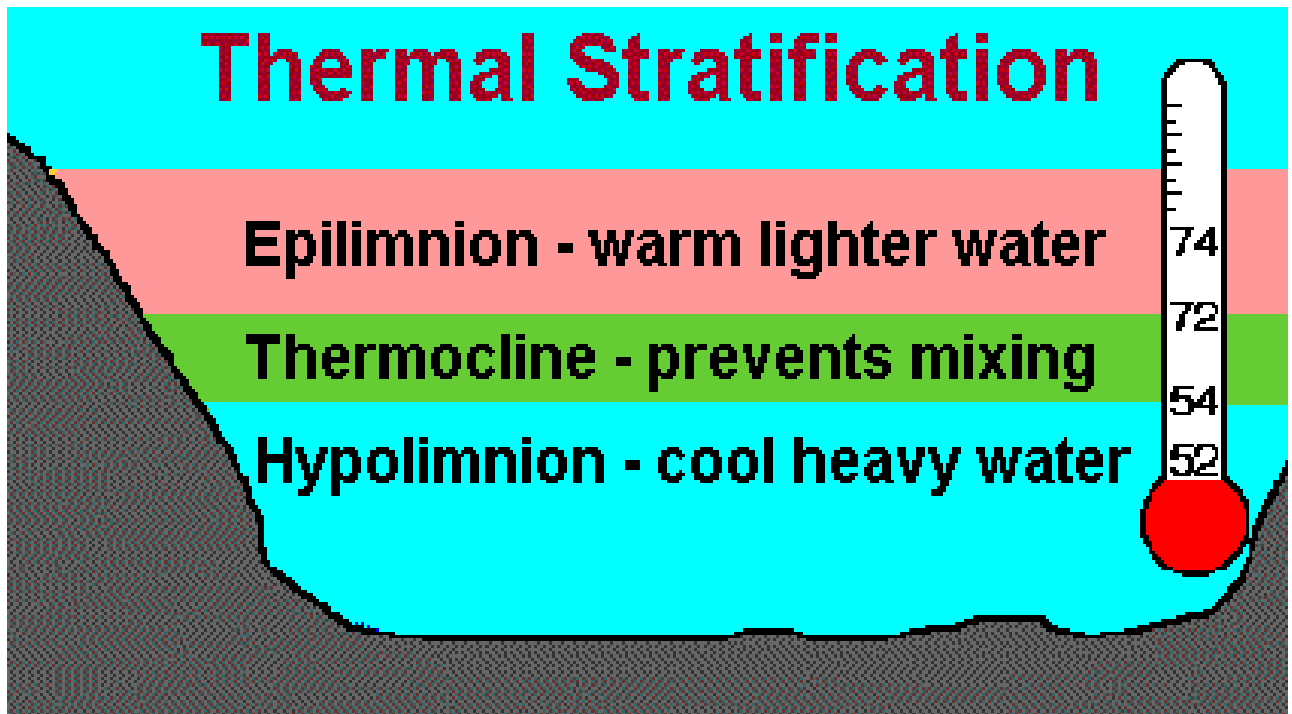

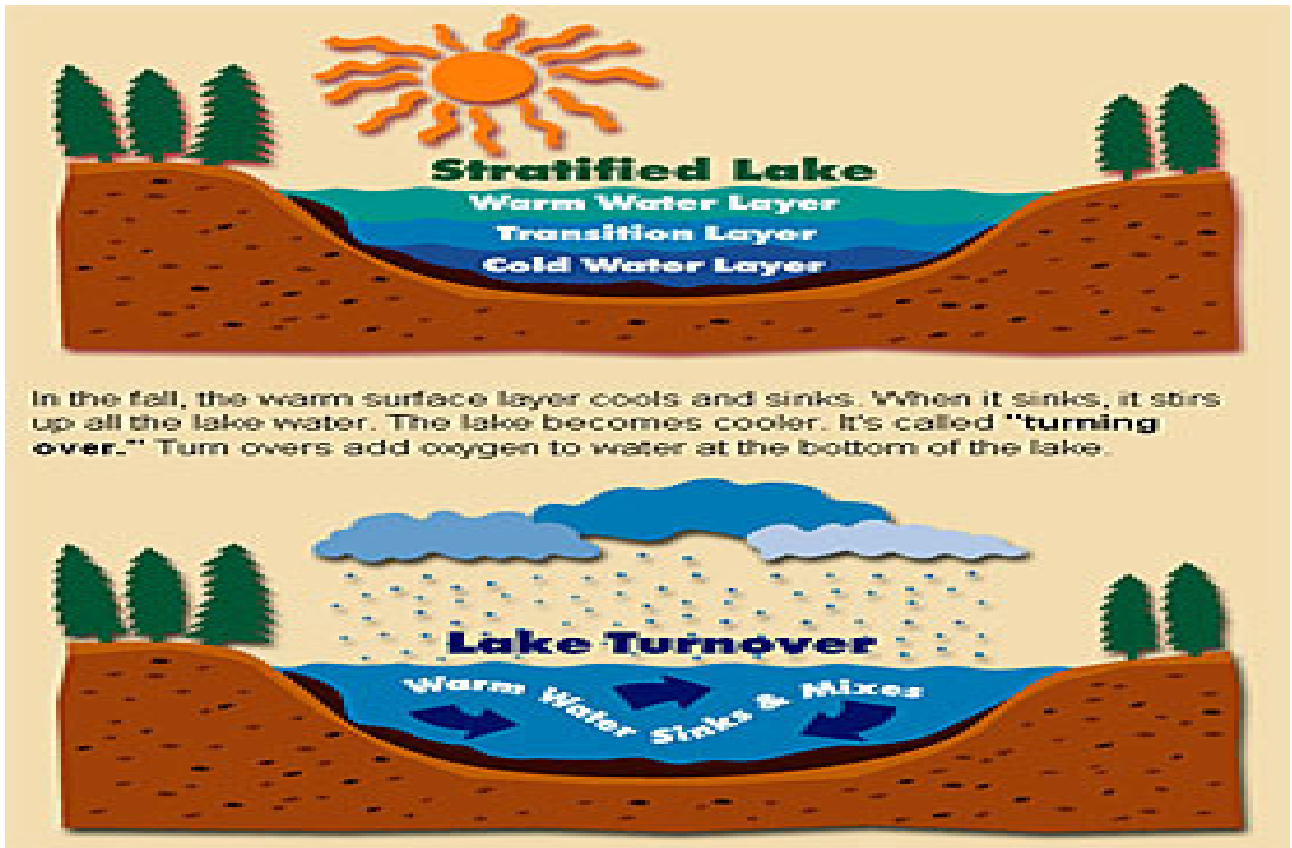

When lakes or reservoirs “stratify”, as in the illustration above, all the entities that have settled out since the last turnover come to the upper regions of the body of water. This layer of settled material can include iron, manganese, organics and any number of other substances that can increase the time, cost, and attention necessary to treat this water and make it potable.

## INTAKES

Because of stratification and changing water levels throughout the year, many treatment facilities have multi-level intakes. Some facilities employ floating intake structures but most are fixed in place. It is important to keep all of the intakes clear so they are available when needed. In multi-level intakes, the top and middle intakes usually provide the best water for treatment.

Some facilities are employing riverbank filtration to allow nature to “clean” the water before arriving at the treatment facility. If done successfully, this will greatly decrease the entities present in surface water and, because of this natural filtration, cut treatment costs. Louisville has recently employed this method with the use of Raney collector wells.

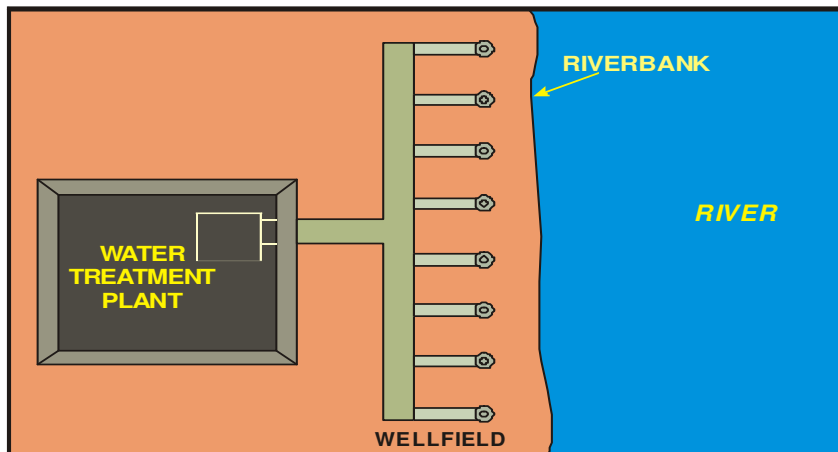
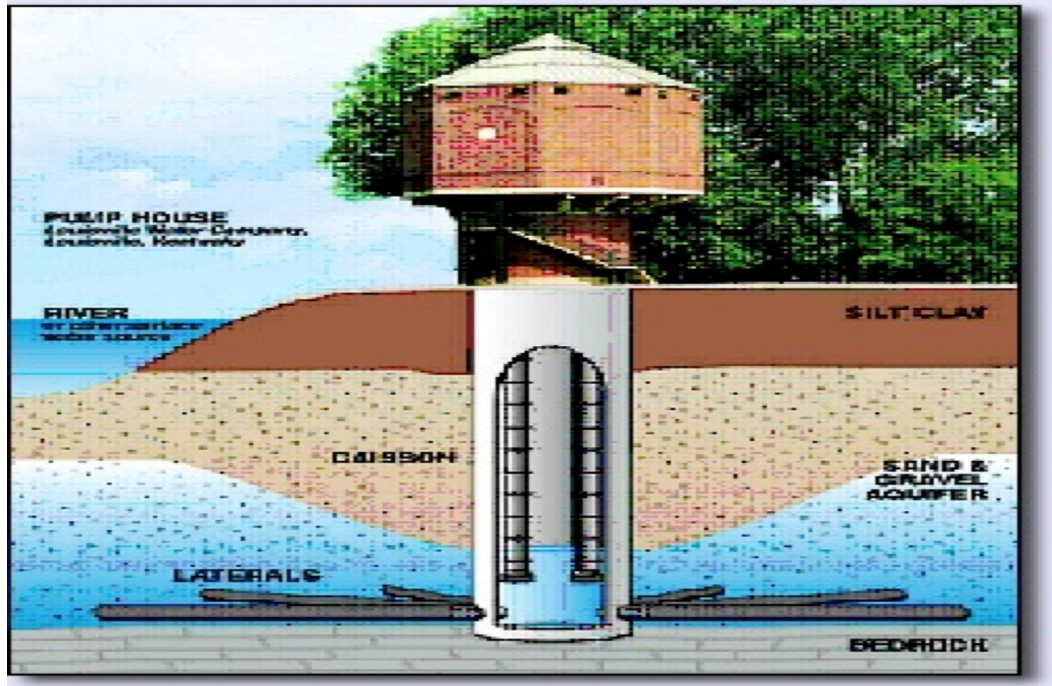



### Cleaner water, naturally

The Louisville Water Co. is implementing a plan to use riverside wells to provide water that is cleaner than that drawn directly from the Ohio River. Here is how it works:

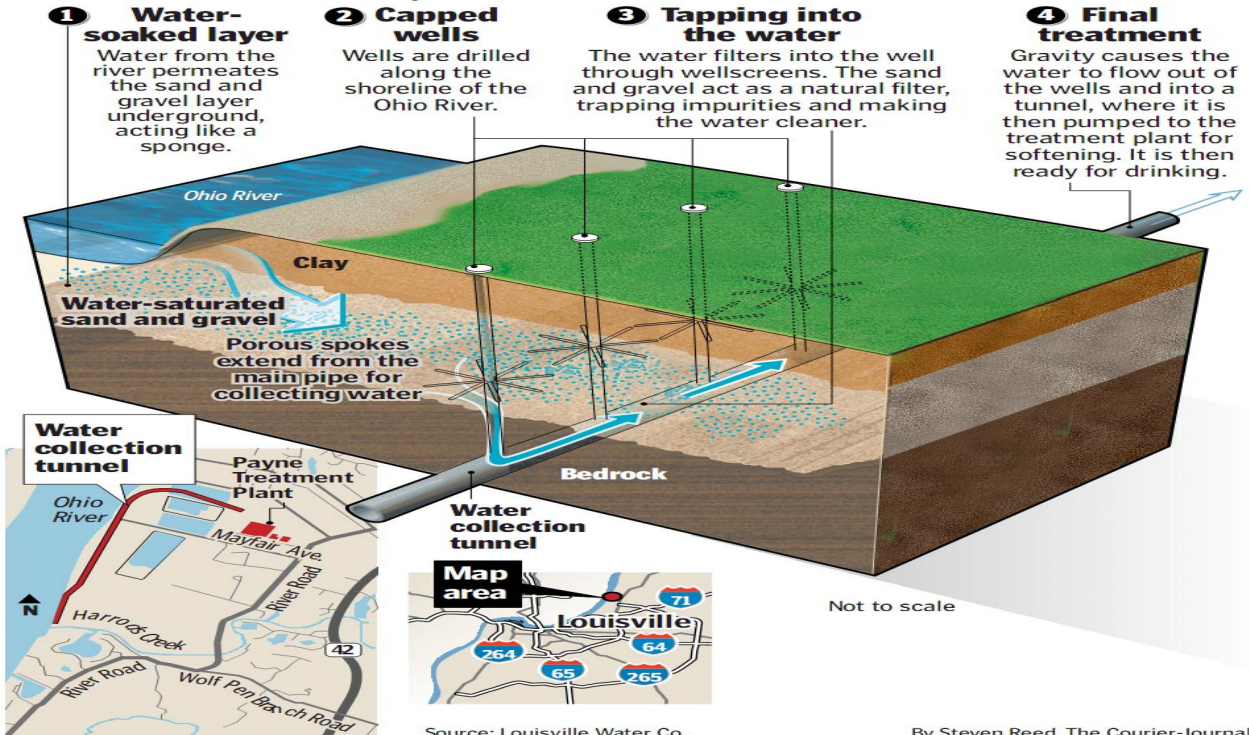

***Review Questions for Chapter 3 – Water Characteristics and Chemistry***

1. Differentiate between health and aesthetic issues.
2. Each transition on the pH scale, for instance from a 6 to a 7, is actually how much of a difference?
3. \_\_\_\_\_ is the ability of water to neutralize acids.
4. What is a very important parameter of the treatment process is one the operator has no control over? Explain the parameter of the treatment process that the operator has no control over.
5. What is measured numerically by the calcium carbonate concentration of water?
6. The cloudy appearance of water is called what? Identify the cloudy appearance of water.
7. What are the two types of color? Name the two types of color.
8. TOC, when in contact with free chlorine produces \_\_\_\_\_? Describe what TOC produces when it comes in contact with free chlorine.
9. One way many of our customers judge the quality of their drinking water is the absence of \_\_\_\_\_ and \_\_\_\_\_. Describe the ways in which customers judge the quality of their drinking water.
10. Water that is cold can hold more \_\_\_\_\_ \_\_\_\_\_ than water that is considerably warmer. Differentiate between cold and hot water characteristics.

***Answers to Review Questions for Chapter 3 – Water Characteristics and Chemistry***

1. Health is illness or death, aesthetic is objectionable to the senses but not the cause of illness
2. 10 times
3. alkalinity
4. temperature
5. hardness
6. turbidity
7. true & apparent
8. DBPs
9. taste & odor
10. dissolved oxygen



# Chapter 4: COAGULATION

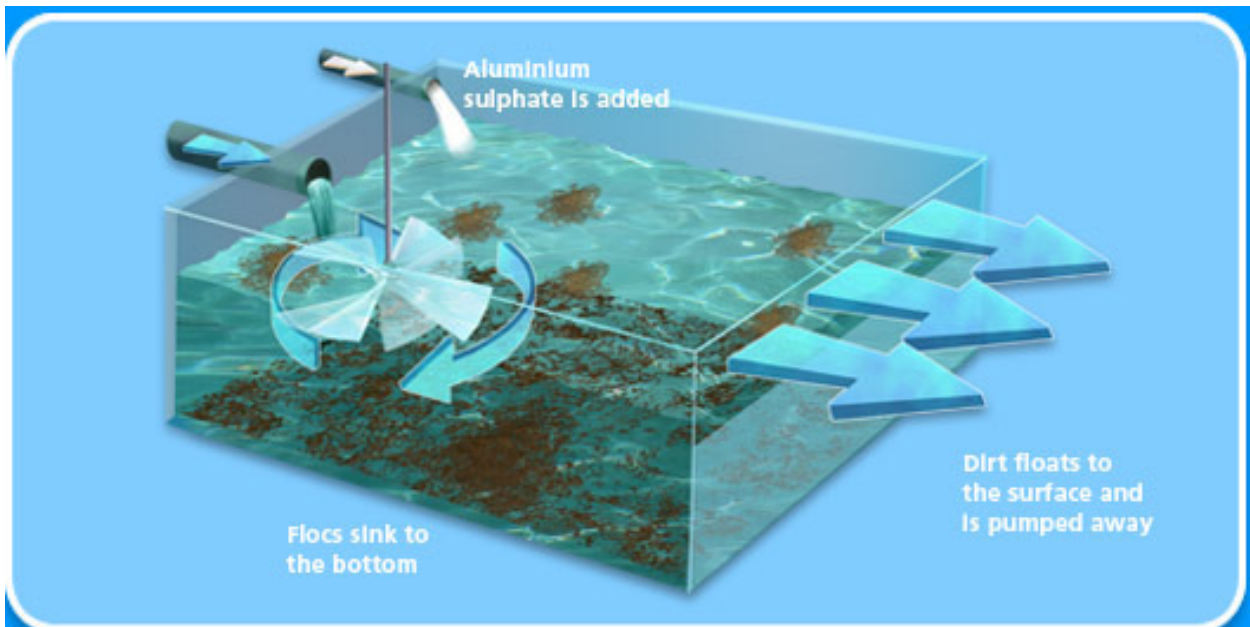

## *Chapter 4 Objectives*

1. Define coagulation, how it relates to rapid mixing and explain what we, as operators, hope to accomplish in this process.
2. Delineate the factors that can positively or negatively impact the coagulation process.
3. Explain how particulate agglomerates, the three types of coagulants and their characteristics, and why one performs superior to the others.
4. Determine what role pH has in successful coagulation.
5. Enumerate the different types of coagulant mixers and determine at least one advantage or disadvantage for each one.
6. Determine what time frame that conventional coagulation is viably achieved and what effects colloids have on the process.
7. Define zeta potential and how it can improve the flocculation process.
8. Determine what test or procedures can greatly assist in ensuring optimal coagulation.

## ***Purpose of Coagulation and Flocculation***

The purpose of coagulation and flocculation is to promote the removal of particulate impurities, particularly nonsettleable solids and color from the water being treated.

## ***Process Description***

- Coagulating chemicals are added to water causing particles to become chemically destabilized and clump together to form floc. These tiny floc particles collide with one another and clump together to form larger floc particles that will settle out.
- Coagulation is the destabilization of colloidal particles brought about by the addition of a chemical reagent known as a coagulant.
- Coagulation uses the addition of a chemical to neutralize the charges on the small suspended (colloidal) particles and cause them to clump together into larger particles that will settle out or can be filtered.
- The mixing of our water and coagulant chemicals is a process called flash mixing. We hope to:
  - Rapidly mix the coagulants
  - Evenly distribute the coagulants
- Coagulation is a physical and chemical reaction occurring between the alkalinity of the water and the coagulant added to the water, which results in the formation of insoluble floc.
- For a specific coagulant the pH determines which hydrolysis species (chemical compounds) predominate. Lower pH values tend to favor positively charged species which are desirable for reacting with negatively charged particulates, forming insoluble flocs and removing impurities from water.
- The best pH for coagulation usually falls in the range of 5 – 7. The proper pH range must be maintained because coagulants generally react with the alkalinity in the water. Residual alkalinity in the water serves to buffer the process (prevents pH from changing) and aids in the complete precipitation of the coagulant chemicals. For instance, the complete precipitation of alum will not occur if alkalinity is too low.

- Lime or soda ash can be added to increase alkalinity if it falls below optimum levels to increase it beyond its saturation point. However, too much alkalinity will retard the removal of organics which are more easily removed at low pH. Both overdosing and underdosing will result in less than optimum particulate removal.
  - 0.5 mg/L of alkalinity is consumed per 1.0 mg/L of alum fed
  - 0.93 mg/L of alkalinity is consumed per 1.0 mg/L of ferric chloride fed
  - Hydroxide Alkalinity
  - mg/L of lime will add 1.35 mg/L of alkalinity
  - mg/L of caustic soda will add 1.25 mg/L of alkalinity
  - Carbonate or Bicarbonate Alkalinity
  - mg/L of soda ash will add 0.94 mg/l of alkalinity

The mixing of the coagulant chemicals and the raw water is called ***flash mixing***. The primary purpose of the flash mix process is to rapidly mix and equally distribute the coagulant chemical (s) throughout the water. This entire process is usually completed in one to thirty seconds.

### *Types of flash mixers*

- **Hydraulic mixing** where flow energy is used (with throttling valves or baffles) to produce turbulence for chemical mixing. Energy usage is minimal but operators must change the flow rate to vary the mixing.
- **Mechanical mixers** utilize paddles, turbines, or propellers to generate the movement of water to accomplish mixing. They can change mixing energies but require electrical energy to do so.

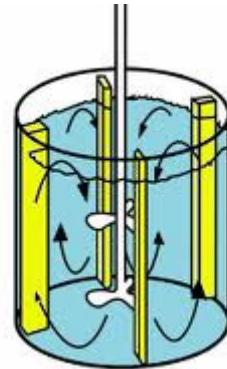
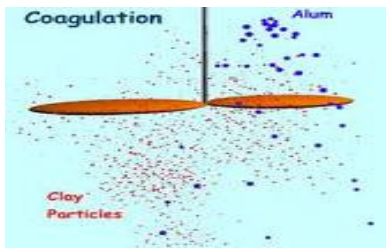

- **Diffusers** use perforated tubes or nozzles to disperse the coagulant into the water providing dispersal over the entire mixing basin. Generally sensitive to flow changes and frequently require adjustment for proper mixing.

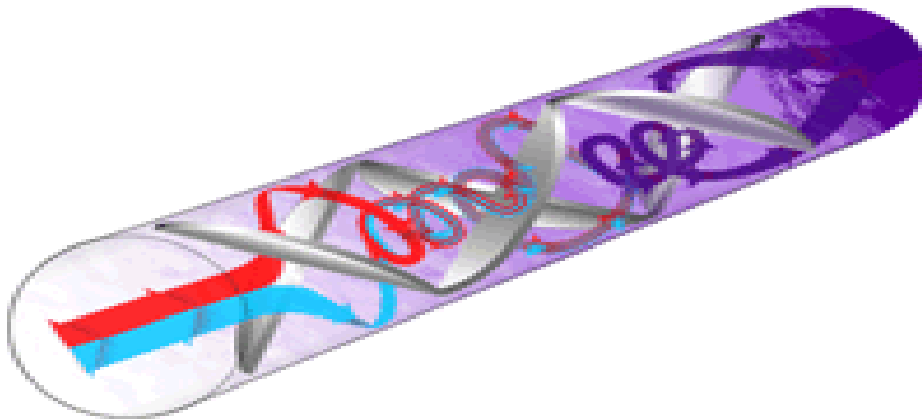

- **Pumped blenders** eject the coagulant into the water through a diffuser in a pipe. They provide rapid dispersion of the coagulant without any significant headloss. Energy consumption is less than mechanical mixing.

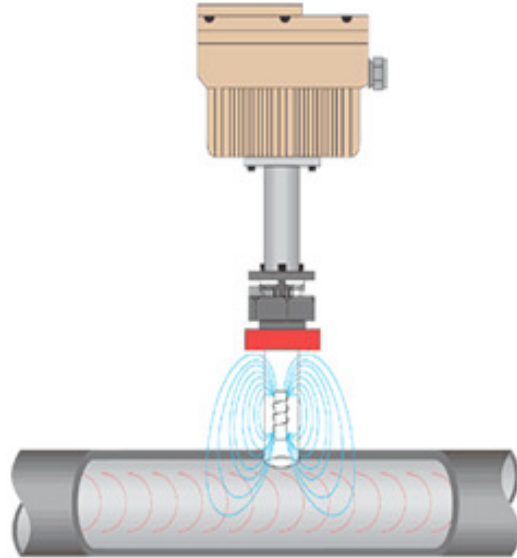

- **Gravity mixing** allows nature's forces to do the work of mixing. If designed correctly this method works very well and requires no mechanical energy to be used.



Some substances in the raw water exist in a dissolved state and must be precipitated into some sort of solid substance before coagulation and flocculation can remove them from the water.

### ***Classification of Particulate Impurities***

There are two classifications of particulate impurities:

- **Settleable solids** – larger particles that can be removed by slowing down the rate of flow and let gravity settle out the particulate;
- **Non-settleable solids** – small particles which must be destabilized to settle out. They agglomerate when destabilized and form floc.

### ***Coagulant Classifications***

Coagulants are classified as **primary** or **secondary** coagulants (coagulant aids).

- **Primary** – cause the particles to become destabilized and clump together.
- **Secondary** – add density and toughness to slow moving floc so they don't tear apart and appear later in the distribution system.

• **Primary coagulants** are characterized as either **metallic salts** such as aluminum sulfate, ferric sulfate, and ferric chloride or as **synthetic organic polymers** or as a blend of metallic salts and polymer blends such as aluminichlorohydrate, polyaluminumchlorate, etc.

- **Metallic salts** – these react with other ions in the solution (our water) . Enough must be added to exceed the solubility of the metal hydroxides. When solubility is exceeded the result is floc formation that will then absorb on the turbidity in the water.
- **Polymers** – these exist as cationic, anionic, or nonionic polyelectrolytes.
  - **Cationic** – positively charged and they have the ability to adsorb on negatively charged turbidity particles and neutralize the charge. They can also form inter-particle bridges that collect the particles in the water. These are mainly used as primary coagulants.
  - **Anionic** - negatively charged polyelectrolytes that are primarily used as coagulant aids.
  - **Nonionic** – possesses a neutral charge and are used as coagulant aids.

## ***Colloids***

Colloids are measured in nanograms which are 1/1,000,000,000 or one billionth of a gram.

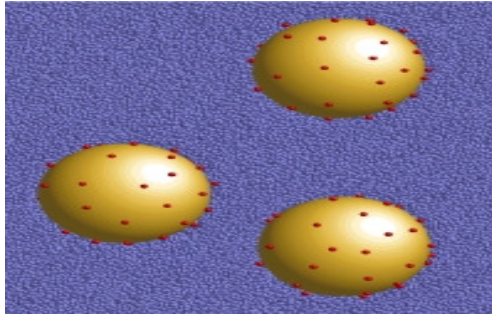

The properties of colloids that are of the most interest to operators are:

- The capacity of colloid particles to adsorb other substances on their surface.
- The tendency for their surfaces to become electrically charged.
- The extraordinarily large surface area expressed in comparison with its mass.
- The tendency for these particles to be in constant motion.

If the colloidal surface charge is relatively high, adjacent colloids will repel each other. The force of gravity is insignificant on small colloids. As a result, highly charged colloids tend to stay in suspension. Colloids with little or no charge have little resistance and will form together into aggregates (floc). Small clumps will form, and in turn, aggregate into larger floc which settle out quickly or form an interconnected matrix. The particle charge can be controlled by modifying the environment around the colloids. This can be accomplished by varying the pH or the ionic species in solution.

A more direct technique is to add flocculants or dispersants to the liquid in suspension. These are surface active agents which adsorb to the colloid and change its surface characteristics including its charge. A direct measurement of the surface charge is not easy so sometimes zeta potential is used instead.

## ***Zeta Potential***

Zeta potential is the electrical voltage difference between the surface of each colloid and its suspending liquid. The potential is caused by the surface charge, so it is a fairly direct measure of the suspension characteristics of the solution. The net charge at the particle surface affects the ion distribution in the nearby region. Because of this, an electrical double layer is formed in the region of the particle liquid interface.

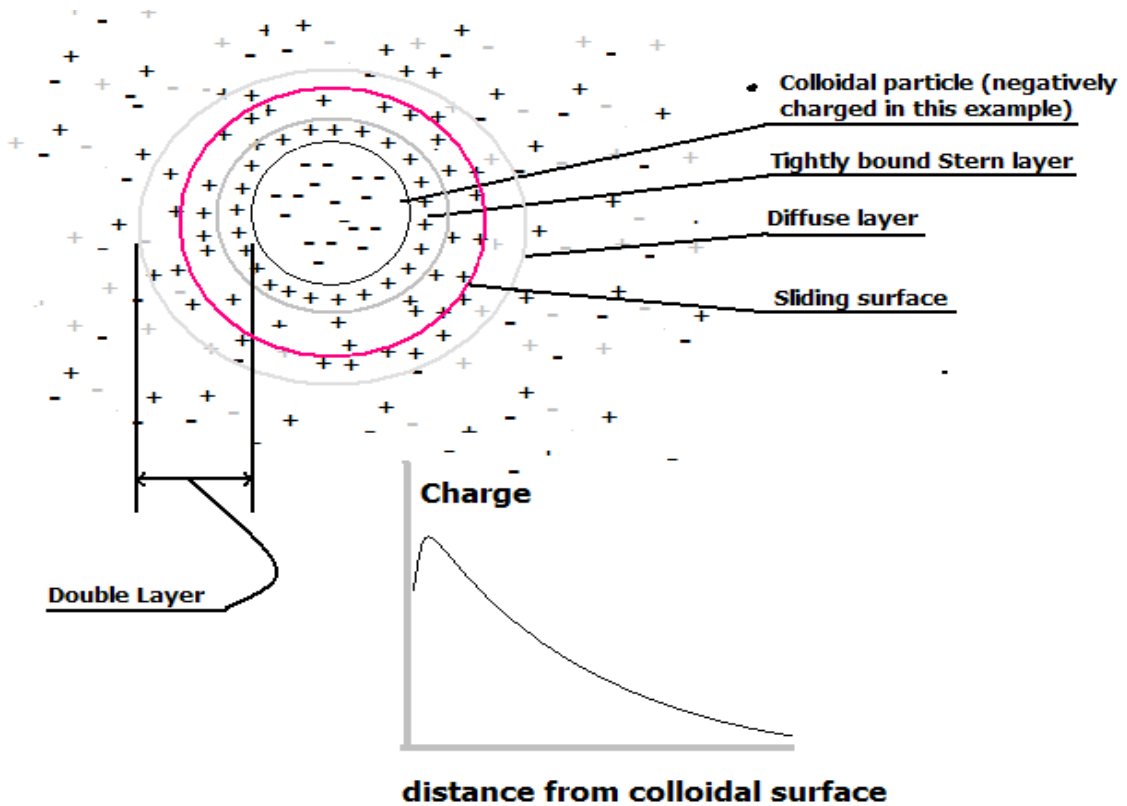

If more alkali is added to this suspension, the particles tend to acquire more negative charge. If acid is added to this suspension, a point will be reached where the charge will be neutralized. Further additions of an acid will cause an abundance of a positive charge.



Generally, a zeta potential versus a pH curve will be positive at low potential. This point is called the **isoelectric point** and is normally the point where the colloidal system is the least stable.

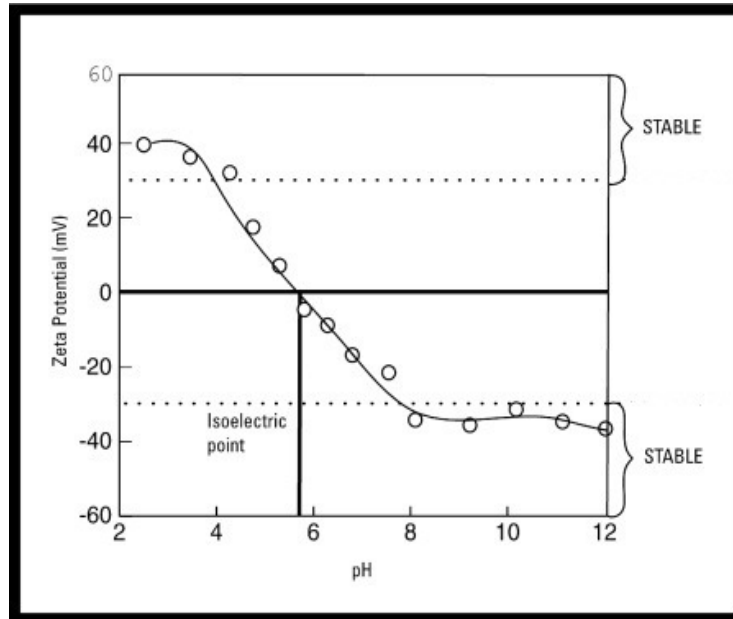

### ***Factors Affecting Coagulation***

- **pH** – For each and every coagulant there is an optimal level at which each coagulant will work best (optimal pH will be reduced with lower temperatures). There is an effective range for each coagulant such as alum which optimal range is 5.5 – 8.5. Lower pH levels provide for better organic removal while higher pH levels favor inorganic removal. Monitoring the pH changes and controlling them through chemical selection and dosage levels.
- **Alkalinity** – Alkalinity is necessary for the development of floc. Higher levels inhibit organic removal so monitoring raw levels is important. Adjust the alkalinity chemically to a feed rate just above the desired level.
- **Temperature** – Temperature determines the speed of chemical reactions; the warmer the temperature the faster the chemical reactions. Temperature also impacts water viscosity, settling rates, filterability, and backwashing. Monitoring to determine the temperatures effect and to develop proper adjustments to significant changes is necessary to optimize treatment processes.

- **Speed and duration of mixing** – For successful coagulation violent and rapid movement is required to mix the chemicals in a matter of seconds.
- **Turbidity** – Turbidity is necessary for floc development with low turbidities sometimes necessitating the addition of coagulant aids. Monitor raw, settled and finished water to determine the effectiveness of your efforts. Try to develop and maintain water quality standards which are < 1.0 NTU for settled water and < 0.1 NTU for finished water.
- **Type and dosage of the coagulant** – Which type works best, metallic salts, polymers or a blend?
- **Pre-oxidation** – Pre-oxidation is necessary to remove dissolved substances such as organic compounds (true color, TOC, algae, etc.) and inorganic compounds (iron, manganese, nitrates, nitrites, etc.) and gases (hydrogen sulfide, methane, benzene etc.). These dissolved substances must be precipitated out in the water so that the coagulation, flocculation, sedimentation and filtration can viably remove them. If your current pre-oxidant doesn't accomplish these tasks you might want to consider a change. Compounds that don't precipitate out will show up later in the distribution system when oxidized by chlorine.
- **Adsorption** – To make your treatment processes (coagulation, flocculation, sedimentation and filtration) more effective the addition of activated carbon will adsorb organic compounds and help optimize your treatment. Powdered activated carbon (PAC) provides better results prior to or after coagulation rather than during coagulation. There are many grades of carbon available and a supply of quality carbon should be kept on hand for periods of greater demand. Optimal dosages can be determined through jar testing.
- **Interfering Substances** – If conflicting chemicals are added to the coagulant chemicals it will result in reduced efficiency.
- **Time** – Detention times are critical to the effectiveness of chemicals and processes. Reduced plant flow and/or baffling will improve detention times and process optimization. Most treatment facilities were designed to operate twenty-four hours a day and operate best if used as they were designed. Avoid short-circuiting of all treatment processes.

## ***Jar Tests***

By far the most effective method to determine optimal dosages of coagulation chemicals is jar testing.



Jar tests allow operators to determine the **optimal coagulant dosage, alkalinity, pH and mixing energies**.

- 1) Using a 1,000 ml graduated cylinder, add 1,000 ml of raw water to be coagulated to each of the jar test beakers.
- 2) Using a prepared coagulant stock solution, dose each beaker with increasing amounts of solution.
- 3) After dosing each beaker, turn on the stirrers. This condition should reflect the actual conditions of your specific plant.
- 4) Now look at the beakers and determine which one has produced the best results, if any!
  - Underfeed will cause the sample to look cloudy with little or no floc and almost no settling.
  - Overfeed will cause a dense fluffy floc to form and inferior settling will occur.

Jar #	ml stock added	ml dosage
1	0.5	5.0
2	1.0	10.0
3	1.5	15.0
4	2.0	20.0
5	2.5	25.0
6	3.0	30.0

### ***Example***

If the plant has a static mixer following chemical addition, followed by 35 minutes in a flocculator, then 1.5 hours settling time before it hits the filters we would conduct the jar tests as follows.

- Operate the stirrers at a high RPM for 1 minute to simulate the static mixer. Then reduce the speed of the stirrers to match the conditions in the flocculator and allow them to operate for 35 minutes. Observe the floc periodically during the 35 minutes. At the end of the 35 minutes, turn off the stirrers and allow settling. Most of the settling will be complete after 1 hour.

You, as an operator, must be able to measure and control the performance of both the coagulation and the flocculation process. Coagulation and flocculation is a **PRETREATMENT** process for the sedimentation and filtration processes. Due diligence is required to operate these processes on an optimum level.

**The goal of an operator should be to produce a consistent settled water quality (1.0 NTU)** so there is a constant and consistent load on the filters day after day. To accomplish this, an operator must continually monitor the raw water quality parameters that impact the process. Significant changes in the raw water quality will require adjustments to the pretreatment process in order to maintain a consistent settled water quality and because of your efforts, a consistent filter loading.

**Process control monitoring** for all controlling factors in the raw and settled water should take place continuously during the operation of the plant. Changes in the raw or settled water characteristics generally require a change in operations. Plant settings and chemical feeds based on finished water turbidity is **NOT** the way to operate a treatment facility. Any adjustment in finished water turbidity will take hours before the results of these changes can be seen. This can lead to very inconsistent finished water quality, inefficiently operated filters and could negatively impact the potability of the water.

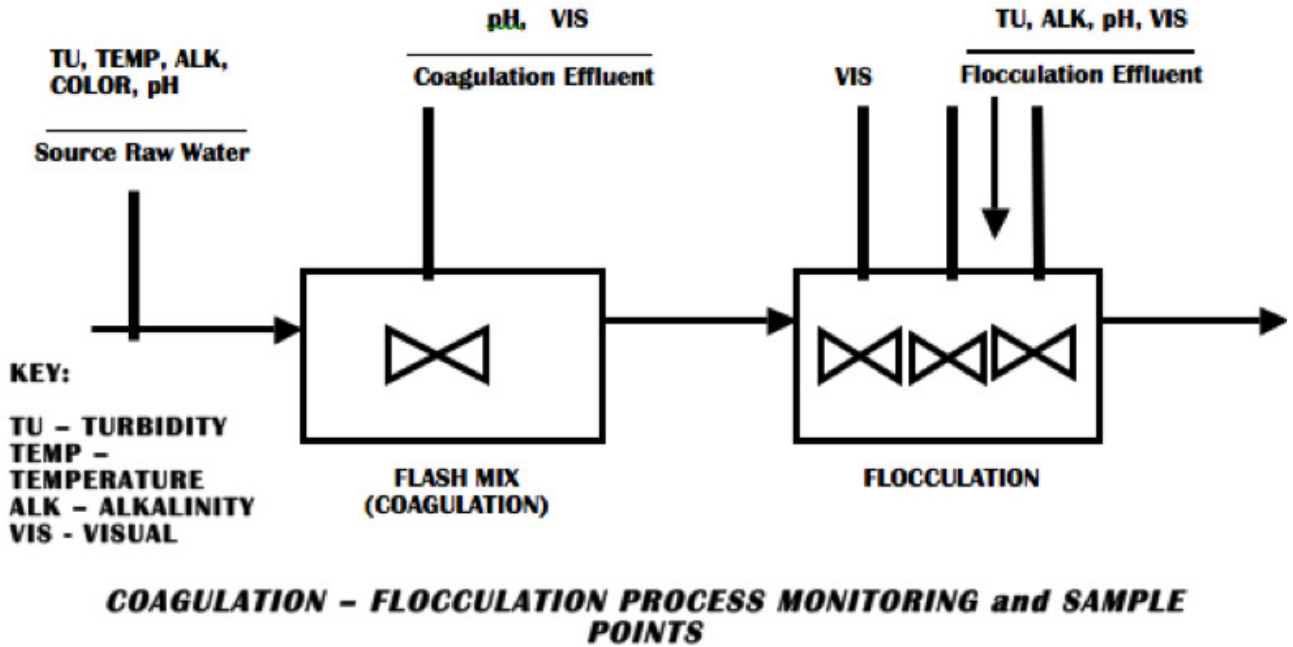

Jar testing is necessary to achieve optimal control and operation. Jar tests are a quick and fairly simple method of predicting what will happen in your plant when chemical or hydraulic changes take place. Jar testing is indispensable for determining optimal chemical dosages, proper mixing speeds, settling rates, chemical demands, and more. Many operators who cannot get the jar test to approximate what happens in their plant dismiss jars as a useful tool. The real issue is the operator hasn't been trained to operate jar tests or the tenacity to figure out how to viably use them in the first place.

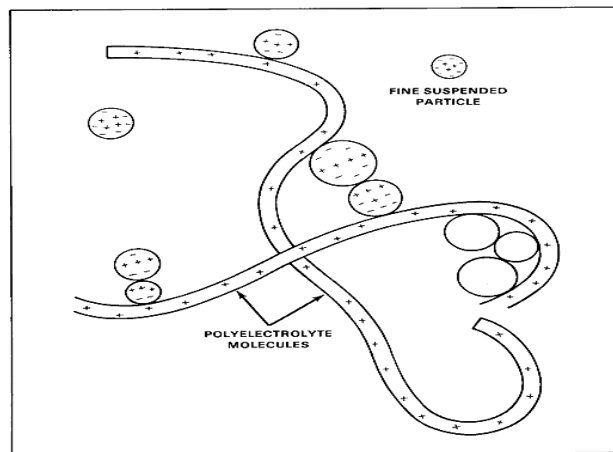
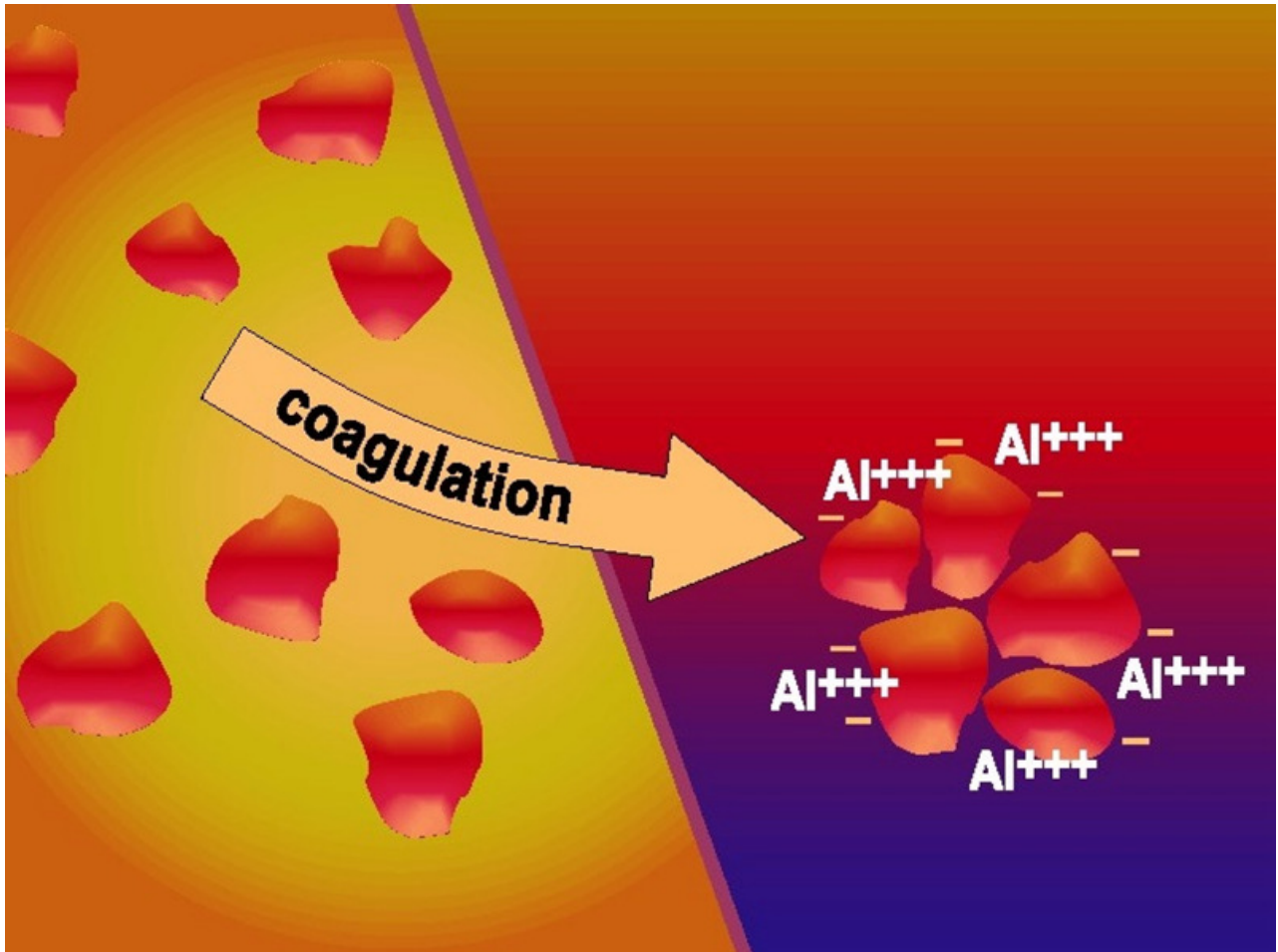

Figure 1-1. Forming a floc particle



**“The most important factor in plant performance is the use of optimal coagulant dosages in pretreatment processes.”**

(W. Bellamy et al, *Journal AWWA*, December 1993)

***Conversions***

Conversions are something we use every day. For instance, we know that four quarters is equivalent to one dollar. One mile is equivalent to five thousand two hundred and eighty feet. In order to properly figure flow, dosages, velocity, etc. we will need to learn how to perform conversions.

1 psi	2.31 feet of head
1 ft of head	0.433 psi
1 cubic feet of water	7.48 gallons
1 cubic feet of water	62.4 lbs.
1 gallon	8.34 lbs.
1 gallon	3,785 ml
1 Liter	1,000 ml
1 Liter	1,000 grams
1 mg/L	8.34 lbs/MG
1 ppm	1 mg/L
1 ml	1 gram
1 pound	453.6 grams
1 pound	7,000 grains
1 kilogram	1,000 grams
1 cuft/sec (ft <sup>3</sup> /sec)	448.8 gpm
1 MGD	1.55 cuft/sec (ft <sup>3</sup> /sec)
1 MGD	694.5 gpm
1 HP	33,000 ft.lbs./min
1 HP	.746 kilowatt
1 mile	5,280 feet

For each conversion there will be only one line that will contain both the entities needed to solve the problem. If the conversion factor known is on the left and you need to convert the number to the equivalency on the right you would multiply. If the known conversion factor is on the right side of this table and you need to know its equivalency on the left you would divide.

**Examples**

- Two miles is equivalent to how many feet?
  - We know the number on the left hand column, two miles, so we multiply the number in the right hand column by two.  
 $2 \times 5,280 \text{ feet} = 10,560 \text{ feet}$
  
- 2083.5 gpm is equivalent to how many MGD?
  - We line up the two entities we need that are on the same line
  - 1 MGD = 694.5 gpm
  - So, what we know is on the right side (694.5 gpm) we are computing from right to left so we divide.
  - $2083.5 \text{ gpm} \div 694.5 \text{ gpm} = 3 \text{ MGD}$
  
- **Try some on your own . . .**
  - 1) 31,680 feet is equivalent to \_\_\_\_\_ miles?
  - 2) 80 feet of head = \_\_\_\_\_ psi?
  - 3) 417 pounds = \_\_\_\_\_ gallons?
  - 4) 5 cuft/sec (ft<sup>3</sup>/sec) = \_\_\_\_\_ gpm?
  - 5) 1736.25 gpm = \_\_\_\_\_ MGD?
  - 6) 5 MGD = \_\_\_\_\_ cuft/sec (ft<sup>3</sup>/sec)?
  - 7) 4 HP = \_\_\_\_\_ ft.lbs./min?
  - 8) 37.4 gallons = \_\_\_\_\_ cuft (ft<sup>3</sup>)?
  - 9) 125.1 lbs. of water \_\_\_\_\_ gallons of water?
  - 10) 5385.6 gpm = \_\_\_\_\_ cuft/sec (ft<sup>3</sup>/sec)



***Solutions***

- 1)  $31,680 \text{ feet} \div 5,280 \text{ feet} = 6 \text{ miles}$
- 2)  $80 \text{ feet of head} \times 0.433 \text{ psi} = 34.64 \text{ psi}$
- 3)  $417 \text{ pounds} \div 8.34 \text{ pounds} = 50 \text{ gallons}$
- 4)  $5 \text{ ft}^3/\text{sec} \times 448.8 \text{ gpm} = 2244 \text{ gpm}$
- 5)  $1736.25 \text{ gpm} \div 694.5 \text{ gpm} = 2.5 \text{ MGD}$
- 6)  $5 \text{ MGD} \times 1.55 \text{ ft}^3/\text{sec} = 7.75 \text{ ft}^3/\text{sec}$
- 7)  $4 \text{ HP} \times 33,000 \text{ ft. lbs/min} = 132,000 \text{ ft. lbs/min}$
- 8)  $37.4 \text{ gallons} \div 7.48 \text{ gallons} = 5 \text{ ft}^3$
- 9)  $125.1 \text{ lbs. of water} \div 8.34 \text{ lbs/gallon} = 15 \text{ gallons}$
- 10)  $5385.6 \text{ gpm} \div 448.8 = 12 \text{ ft}^3/\text{sec}$

***Review Questions for Chapter 4 – Coagulation***

1. Another name for the coagulation process that actually describes what takes place in this process is what? Describe the coagulation process and list the names associated with this process.
2. Name three types of mixers used in water treatment.
3. The two classes of particulate impurities are what?
4. The type of polymer, relative to their charge, that is most frequently used in drinking water applications is \_\_\_\_\_?
5. The very small particulate we eventually hope to get settled out if our processes are viable are called \_\_\_\_\_.
6. The average time consumed by the coagulation process is?

***Answers to Review Questions for Chapter 4 – Coagulation***

1. rapid mix or flash mix
2. mechanical, diffusers, pumped blender, eductor
3. settleable & non-settleable
4. positive or cationic
5. colloids
6. seconds

This page left blank intentionally.

# Chapter 5: FLOCCULATION

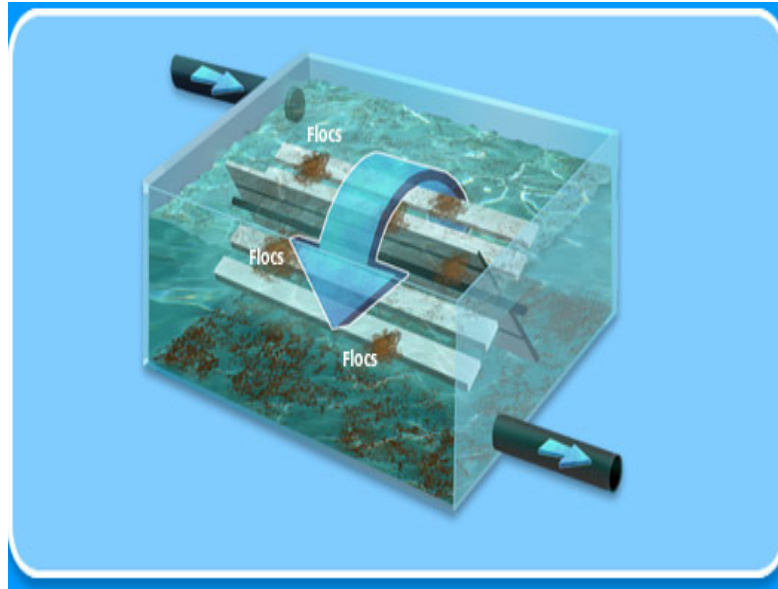

## Chapter 5 Objectives

1. Define flocculation, what we as operators hope to accomplish in this process and the factors that impact this process.
2. Notate the types of mechanical flocculators that are used to accomplish the conjoining of particulate matter?
3. Determine the refinement of conventional flocculation that achieves a higher number of the type of particulate agglomeration desired.
4. Define floc, enumerate the visual indicators of successful floc formation and circumscribe the length of the process.
5. Define short circuiting and what role, if any, baffling could have on the flocculation process.
6. Determine the last area in the flocculation process that could negatively affect proper floc formation.
7. Determine the way, if there is one, that the flocculation process could be optimized.
8. Explain jar testing, what equipment is necessary and why they aren't used.

## ***Flocculation***

A slow stirring process that causes the gathering together of small coagulated particles into larger settleable particles. This process provides contact between these particles in order to promote the formation of floc that is easily removed by sedimentation and filtration. This process can take anywhere from thirty minutes to several hours to complete.

### **FOR ALL INTENT AND PURPOSES COAGULATION AND FLOCCULATION ARE A SINGLE PROCESS.**

In order to achieve optimum particulate removal it is necessary to create enough mixing in the flocculation process to enhance the collision of particles thereby forming floc while preventing excessive mixing that could shear floc that was previously formed.

We need to create floc of proper **SIZE, DENSITY** and **TOUGHNESS**.

**Effective flocculation** includes:

- 1) Correct detention time (stirring time)
- 2) Correct stirring intensity
- 3) Properly designed mixing basin
- 4) Some means of providing enough stirring action

Insufficient mixing results in unproductive collisions and inferior floc formation.

Excessive mixing could promote the tearing apart of the floc particles after their formation.

Detention time is the most important variable in the flocculation process assuming the flocculators are working. The greater the detention time then usually the better the floc.

- **MINIMUM 30 minutes**
- **IDEAL 1 – 2 hours**

Too small floc particles will not have the weight to properly settle, while too large floc particles will present buoyant properties that will also negatively impact settling.

The density of the floc in combination with the plant flow rate will determine when and where the floc will eventually settle out in your plant. If the floc is settling out before the sedimentation process, the plant flow rate can be increased. If the floc is carrying over from the sedimentation process, the plant flow rate should be reduced. In either instance, the coagulation chemistry can be changed instead of changing the plant flow rate since the flow rate affects all treatment processes.

Since we want the floc particles to be evenly distributed throughout the water, there should be no eddy currents or debris buildup present in the basins.

### *Types of Flocculators*

- **Horizontal Stirrers:** Paddlewheel or rocker-arm varieties provide the best flocculators available but require frequent maintenance and intensive energy use.

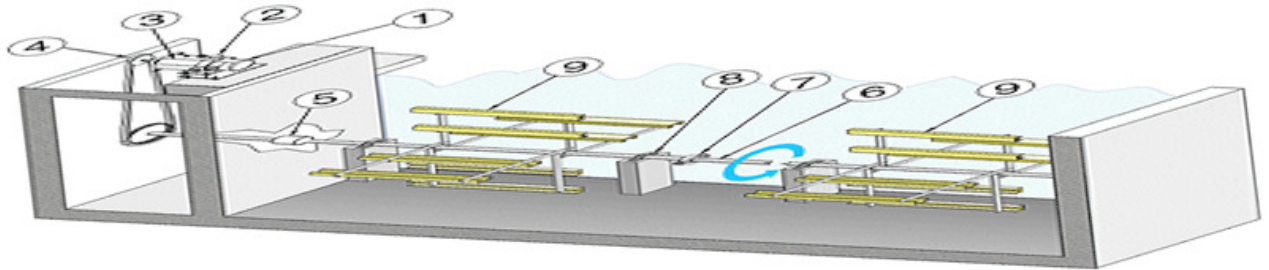

- **Rocker Arm**

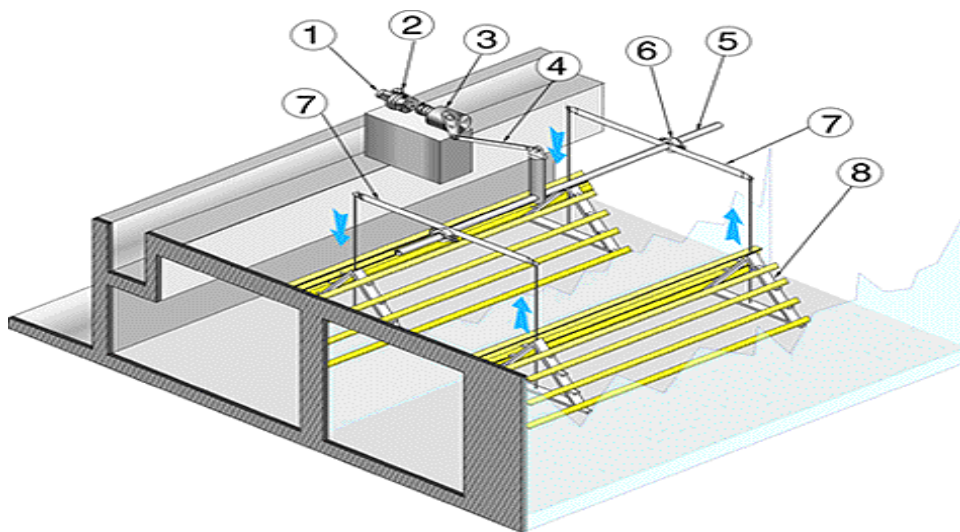

- **Vertical Stirrers:** Paddles, turbines, or propellers provide satisfactory performance with less maintenance required. Their tendency to short circuit can be offset with baffling.

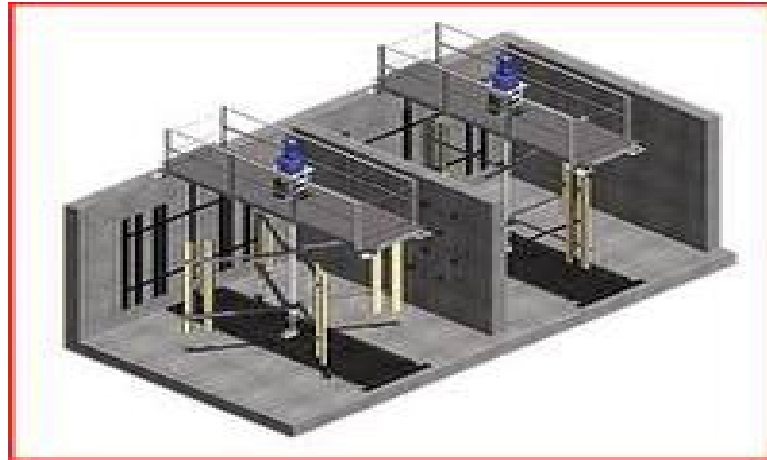

The best flocculation basins are compartmentalized. The compartments (usually three) are separated by baffles to prevent short-circuiting. The turbulence of the water is gradually reduced by slowing the speed of the mixers or the size of the flocculator paddles in each successive compartment. The reason for reducing the speed of the stirrers is to prevent the breaking apart of the large floc particles that have already formed; and also reduce the velocity of the water so that these formed floc particles may begin to settle out. Compartmentalized flocculation is also known as **step flocculation**.



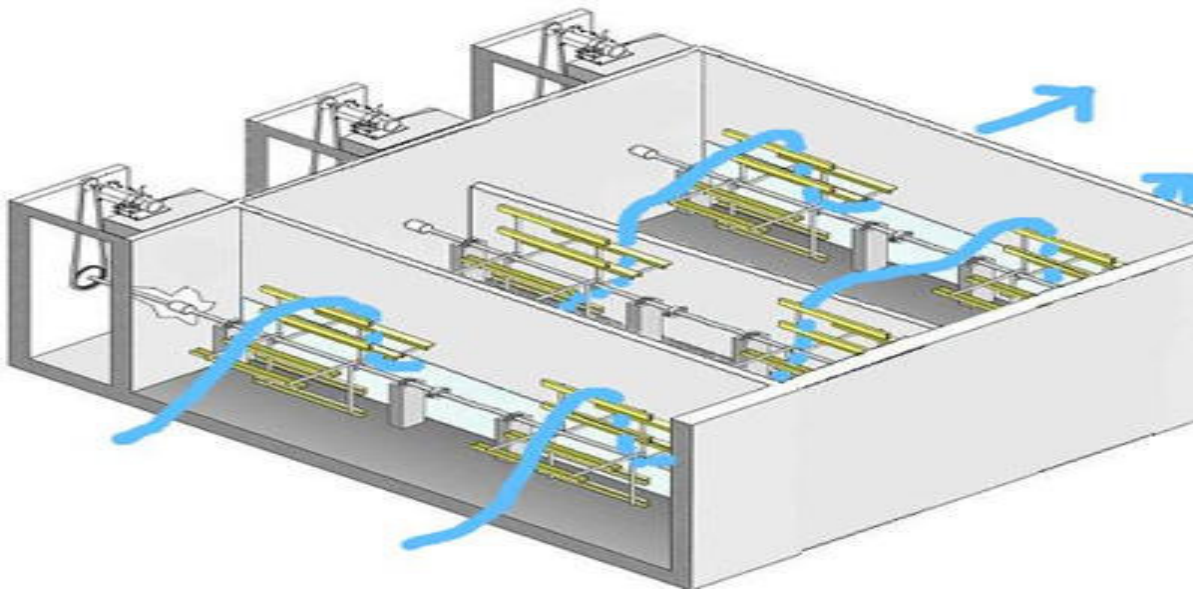

- **Weirs, baffles, and orifices** are flow regulating devices which improve the flocculation process by creating additional turbulence for mixing. The effluent end of the floc basin needs to offer a smooth and gradual transition into the sedimentation basin.



The optimum velocity is from 0.1 to 1.5 ft/min. Flows  $< 0.1$  ft/min causes inferior floc formation. The efficiency of your efforts relative to coagulation and flocculation will

greatly determine the success of your entire treatment process. The lack of diligence or competency can result in:

- Small particles will not settle out and will pass through the filtration process.
- Poor disinfection will result if the coagulation/flocculation process isn't optimized.
- Disinfection Byproducts such as trihalomethanes will most likely increase.

Visual observations as well as lab tests are essential to successful coagulation and flocculation.

Necessary visual checks include:

- floc patterns in the floc mixing chamber
- uneven floc in the floc basin
- floc density and size
- influent channel buildup of debris
- condition of all mechanical equipment (pumps, motors, blades, etc.)

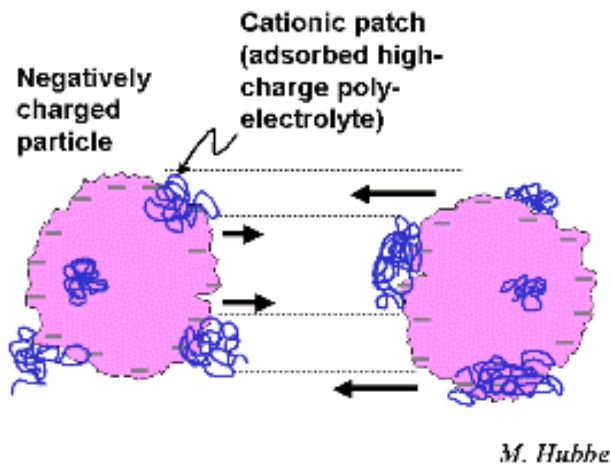

### ***Common Coagulation and Flocculation Problems***

<b>PROBLEMS</b>	<b>POSSIBLE CAUSES</b>	<b>POSSIBLE SOLUTIONS</b>
<b>Poor floc formation</b>	Inadequate coagulant dose	Run jar tests; determine optimum coagulant dose and increase dosage as required.
	Improper detention time	Run jar tests; apply needed detention time , if possible, by adjusting flocculator speed or changing the flow rate
<b>Feathery, flakey floc</b>	Usually excess lime which has a low solubility. Excess lime will precipitate as calcium hydroxide and form light floc.	Run jar tests. Lower lime dose as needed.
	Inadequate coagulant dosage	If excess lime is desirable, increase coagulant dosage until floc quality is improved.
<b>Floc settles in the coagulation process</b>	Velocity in basin is too low	Check velocity and flocculator speed and adjust as needed.
<b>Poor flocculation even when optimum doses of coagulant is used</b>	Improper mixing	Check rapid mix and mixer speed; adjust as needed

<b>Poor floc formation under winter conditions with low turbidity</b>	Not enough turbidity for effective flocculation	Try some weighing coagulant aid such as clay or sodium silicate
	Improper detention time. Low temperature causes slower coagulation which necessitates longer detention time	Determine optimum coagulant dosage through jar tests and employ the changes.
<b>Inadequate flocculation or yellowish water.</b>	Color of water is due to decomposition of NOM like leaves, rotting vegetation, etc.	Provide low pH and high coagulant dosage. Alum lowers pH by forming sulfuric acid in the water.
<b>Inadequate flocculation in the summertime with low turbidity</b>	Drought conditions. A lack of proper dilution factor and high concentration of minerals causing poor floc formation.	Run jar tests to optimize dosages. Run jars without coagulant aid to ensure their necessity.
<b>Floc settles in coagulation basin</b>	Excessive coagulant dose forms heavy floc. Weighting coagulant aid dosage is too high.	Run jar tests to optimize dosages. Run jar tests without aid to ensure their necessity.

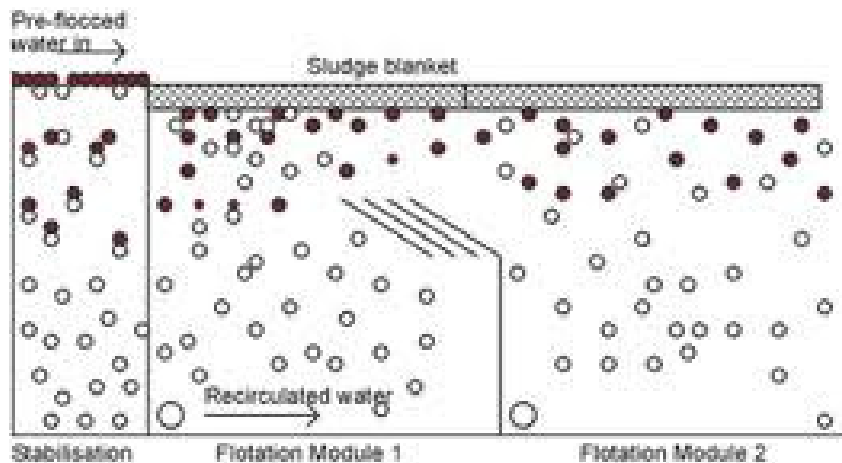

***Review Questions for Chapter 5 - Flocculation***

1. As a competent operator, we want to form floc of the proper \_\_\_\_\_, \_\_\_\_\_, and \_\_\_\_\_.
2. The optimal detention time for coagulation is between \_\_\_\_\_ and \_\_\_\_\_ hours.
3. The optimum velocity for the coagulation process is \_\_\_ feet per minute. Identify the optimum velocity for coagulation.
4. Name two types of flocculators.
5. Necessary visual checks of the flocculation process include? Describe the necessary visual checks of the flocculation process.
6. Explain the optimal colloidal particulate condition.

***Answers to Review Questions for Chapter 5 - Flocculation***

1. Size, density, toughness
2. ½ to 3 hours
3. .1 to 1.5 ft/min
4. horizontal, paddlewheel, rocker-arm, vertical, paddles, turbines, or propellers.
5. Floc patterns, density, size, uneven floc formation, influent channel debris, the condition of the mechanical equipment
6. neutralized

# Chapter 6: SEDIMENTATION

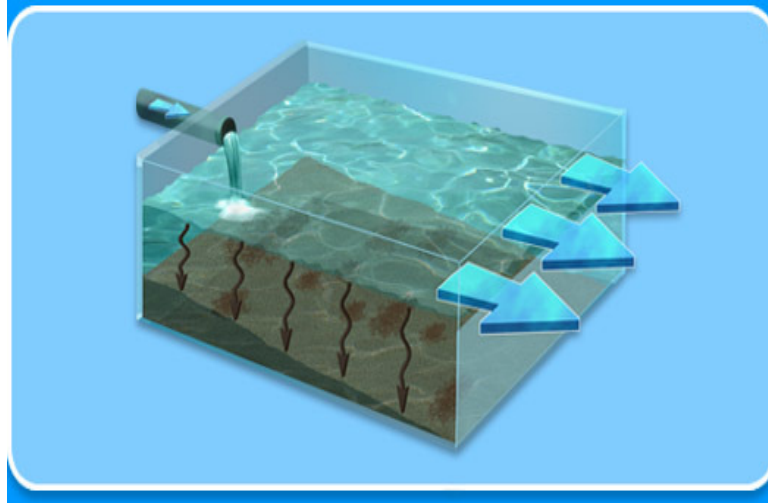

## Chapter 6 Objectives

1. Define sedimentation, what affects sedimentation and how to know if the process is successful.
2. Determine the difference in settling rates of different shaped particulate.
3. Decide whether alkalinity and turbidity will increase or decrease as the water moves through the coagulation, flocculation and sedimentation processes.
4. Explain how tube settlers and lamella plates operate.
5. Determine what time frame conventional sedimentation operates in and the velocity the water is traveling through the process.
6. Define short-circuiting and determine which shape of basin is the most susceptible to it.
7. Define sludge, what happens if it isn't removed on a timely basis, what to do with it and why.
8. Describe where, optimally, turbidity levels should be observed during the sedimentation process.
9. Be able to list the four zones of a sedimentation basin.
10. Calculate the surface area and volumes of certain structures.

## ***Sedimentation***

We use the sedimentation process to reduce suspended solids (natural, modified, and precipitated) that are denser than water. The process is also needed to reduce, or at least to maintain, the load on filters.

Sedimentation is the decreasing of the velocity of the water below the point where it can transport settleable suspended material, thus allowing gravitational forces to remove particles held in suspension. As the water becomes almost still in sedimentation basins, settleable solids will fall toward the bottom of the basin.

## ***Sedimentation Goals***

- Turbidity  $\leq 2$  NTU 95% of the time when source water turbidity is  $>10$  NTU
- Turbidity  $\leq 1$  NTU 95% of the time when source water turbidity  $\leq 10$  NTU

## ***Why Optimization and Performance Goals***

The USEPA did a pilot study to assess *Cryptosporidium* removal through conventional sedimentation. (Dugan 2001)

- Sedimentation removal under sub-optimal coagulation averaged 0.2 log *Crypto* removal.
- Sedimentation removal under optimal coagulation averaged 1.3 log *Crypto* removal.

As the velocity of the water is reduced, gravity takes over and allows the solids to settle to the bottom of the basin.

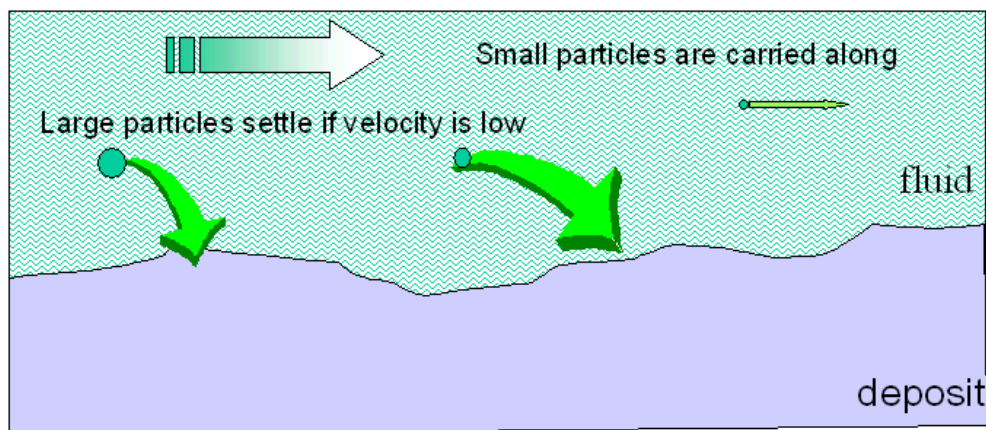



***Factors Affecting Sedimentation***

- Particle size and distribution
- Shape of particles
- Density of particles
- Temperature of the water (viscosity or density)
- Electrical charge of the particles
- Dissolved substances in the water
- Flocculation characteristics of the suspended material
- Environmental conditions (wind, precipitation, etc)

Particle Diameter	Representative Particle	Time Required to Settle in 1 foot (.3 meters) Depth
		<b>Settleable</b>
10	Gravel	0.3 seconds
1	Coarse Sand	3 seconds
0.1	Fine Sand	38 seconds
0.01	Silt	33 minutes
<b>CONSIDERED</b>	<b>NONSETTLEABLE</b>	<b>PARTICLES</b>
0.001	Bacteria	59 hours
0.0001	Color	230 days
0.00001	Colloidal particles	6.3 years

### ***Particulate Impurity Nature***

Because of their size and density, sand and silt particles (> 10 microns) can be removed by simple gravitational settling. The finer particles don't readily settle out and are the ones that require pre-treatment in order to produce larger, denser particles that are settleable. Particle shape will also influence settling. Smooth circular particles will settle out more quickly than jagged irregular shaped particles.

### ***Water Temperature***

The settling rate of a particle becomes slower as the temperature drops. Because of this the colder the water the longer the time period (detention time) required for effective settling to occur. In the water, flow rate will need to be decreased and/or chemical dosages will need to be increased.

### ***Electrical Charge on Particles***

Most particles carry a slight electrical charge. If the majority of the particles have a negative charge, they tend to repel each other and not settle. Most coagulants, such as alum, have a positive charge which causes the negatively charged particles to become attracted to the positively charged aluminum ions. This causes clumping together which gives the particles a greater density and allows them to settle out by gravity.

### ***Environmental Factors***

Surface currents caused by wind can cause havoc with effective sedimentation. Precipitation can also have a profound influence on the viability of the sedimentation process.

### ***Sedimentation Basin Hydraulics and Design Characteristics***

There can be several types of currents found in sedimentation basins. Density currents that are caused by differences in suspended solid concentrations and temperature differences. Eddy currents caused by the flow of the water into and from the basin.

***Sedimentation Basin Zones***

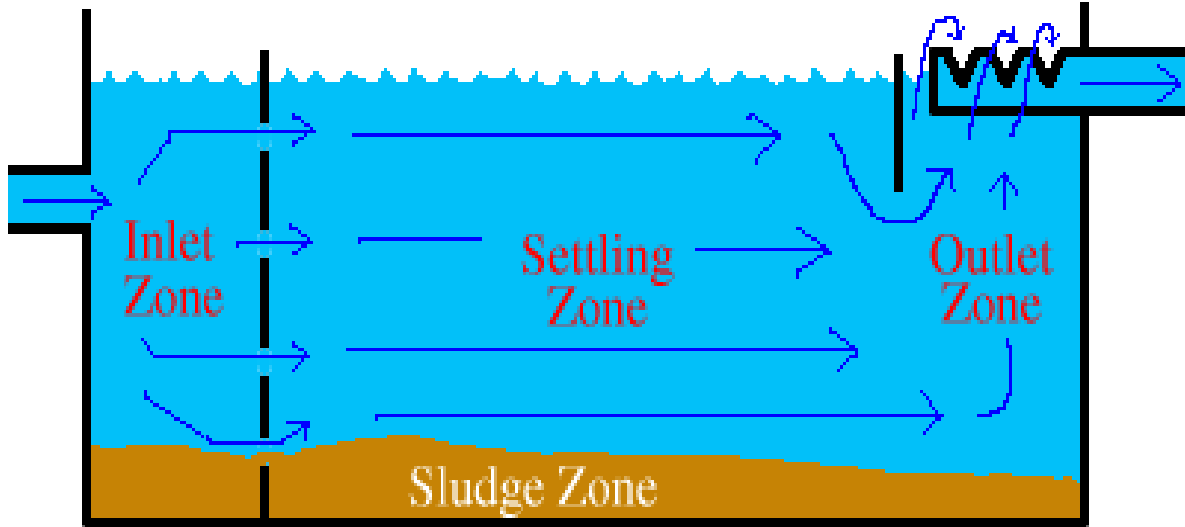

**Inlet** - Obviously where water enters the basin.

A smooth transition is needed from the flocculation basin(s) to the sedimentation so the flow of water can be uniformly dispersed into the basin. Short circuiting can be greatly reduced by baffling which can also help counteract temperature variances.

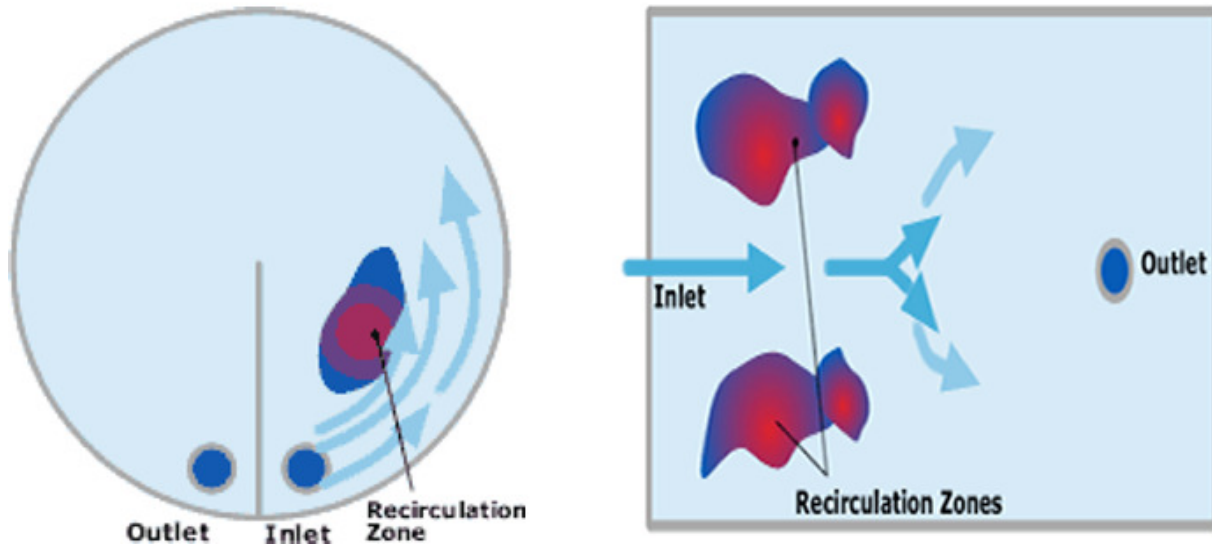

**Circular basins are more prone to short circuiting than rectangular basins.**

### Settling

The largest area of the sedimentation basin.

- The calm water provides sufficient time for suspended particles to settle out.
- The horizontal velocity should be  $< 3 \text{ ft/min.}$ , usually the slower the velocity, the better the settling.

### Sludge

This area provides temporary storage of settled particles. The entire basin should be designed to minimize disturbances to the settled particles. This area needs to be cleaned frequently enough so the hydraulic characteristics of the basin aren't impacted and the settled particulate or sludge doesn't become septic.

### Outlet

This area transitions the flow from the sedimentation basin to the next process. This transition needs to be smooth and devoid of any buildup so the flow rate remains the same and currents are initiated.

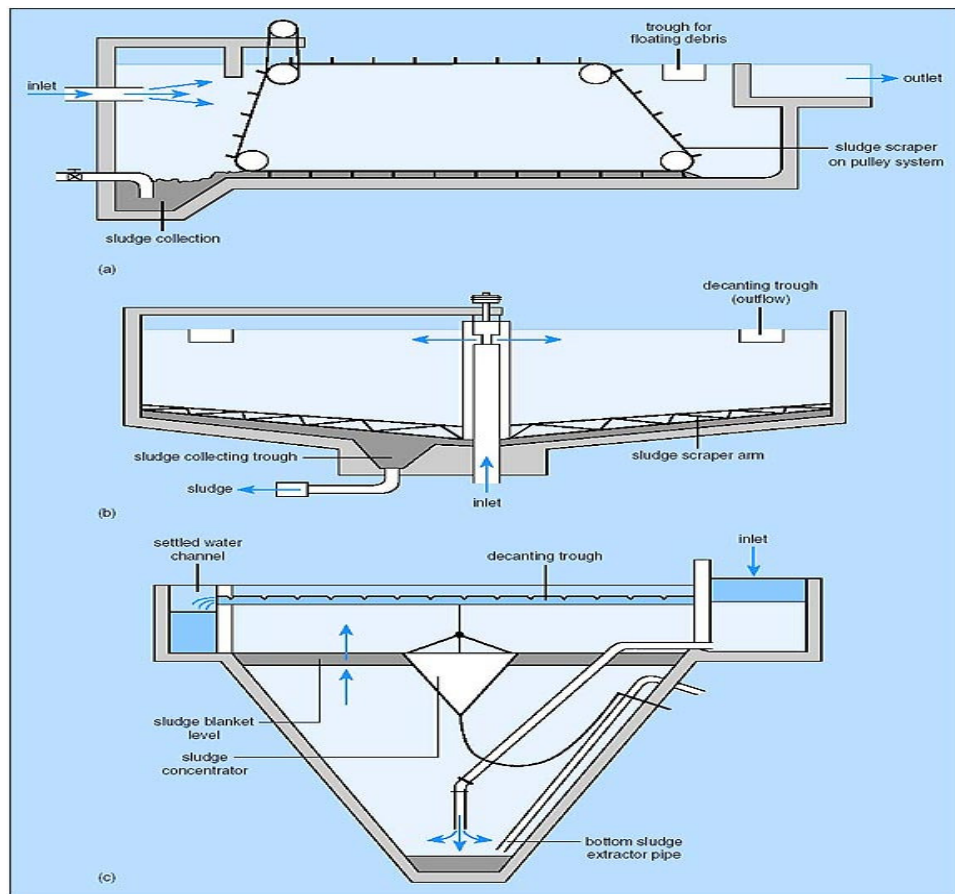

***Launders and V-notch weirs***

- Collects water from the sedimentation basin
- Controls uniformity of flow
- If the outflow is high floc will carry over to the filters



### Tube Settlers

Tube settlers are small inclined tubes situated in the sedimentation basin. These “settlers” increase the surface area in relation to volume so the particulate collect on that surface area and settle out completely later. These provide the polishing step of the sedimentation process. To date tube settlers are the most efficient way to improve the settling process.

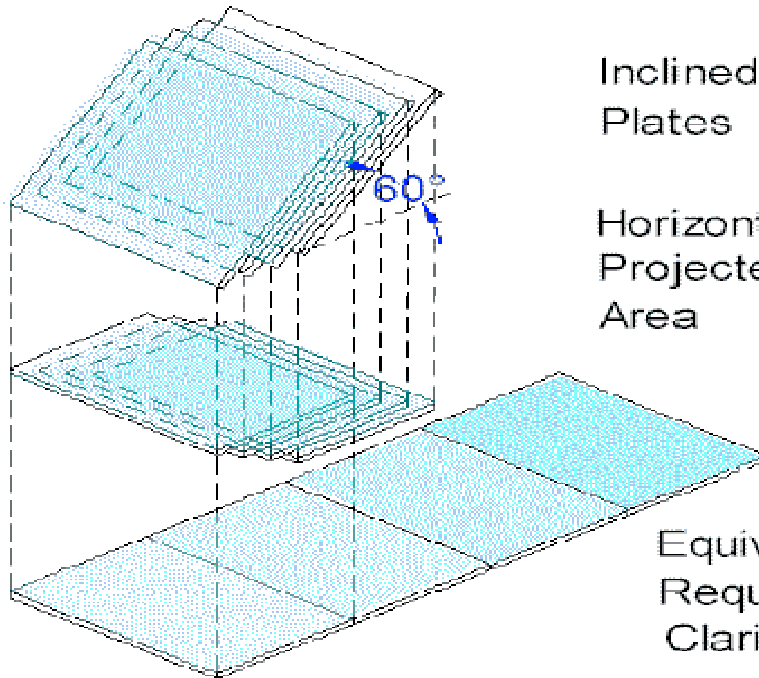

Inclined Plates

Horizontal Projected Area



Equivalent Floor Space Required by a Horizontal Clarifier

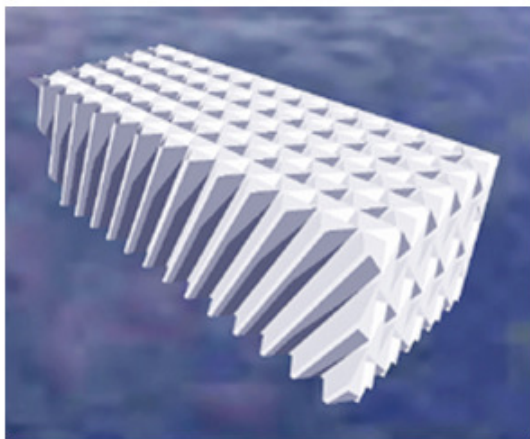

Tube Settlers vs. Conventional Settling

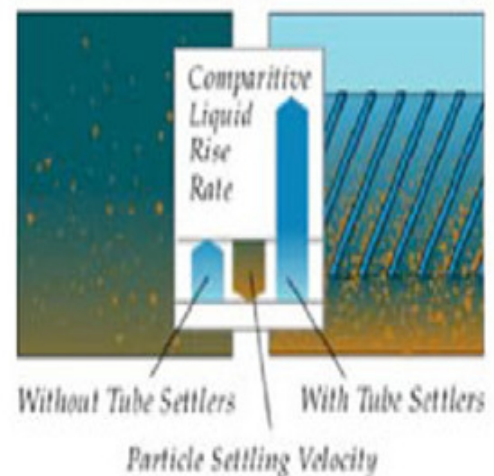

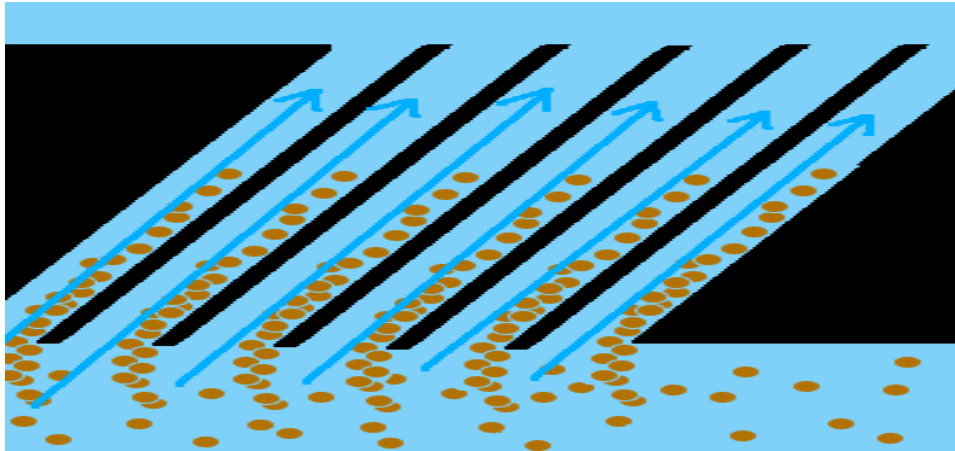

The pretreatment process (coagulation/flocculation) determines the effectiveness of the sedimentation process. The settling characteristics of the suspended particles and the flow rate will dictate efficiency of the process. If your efforts with the sedimentation process fail to meet settled water turbidity goals (such as 1.0 NTU) the oxidation, coagulation, and/or flocculation process needs to be improved.

### ***Sludge Handling***

Sludge, which accumulates at the bottom of sedimentation basins, must be removed periodically for the following reasons:

- To prevent interference with the settling process (i. e. scouring),
- To prevent the sludge from becoming septic or providing an environment for microorganisms that will cause taste and odor problems, and to prevent the reduction of basin size and thus basin detention time, and
- Can change the effective size of the basin.

In conventional rectangular basins 50% of the sludge should settle out in the first third of the basin. Many basins have automatic sludge removal systems (traveling bridge, chain and flight, rotating sludge rakes, etc.) while others still require the manual removal of the sludge. To determine when to remove sludge, sludge levels can be measured in a number of ways:

- Sludge blanket sounders
- Bubbler tubes
- Aspirators
- Ultrasonic level indicator

Regardless of what type of basin your plant has the sludge will have to be removed at one time or another. Since sludge is an accumulation of chemicals and contaminants and pollutants that we removed from the raw water. It is unlawful to put this sludge ANYWHERE without a permit. Most all sludge requires some treatment before its end usage or disposal.

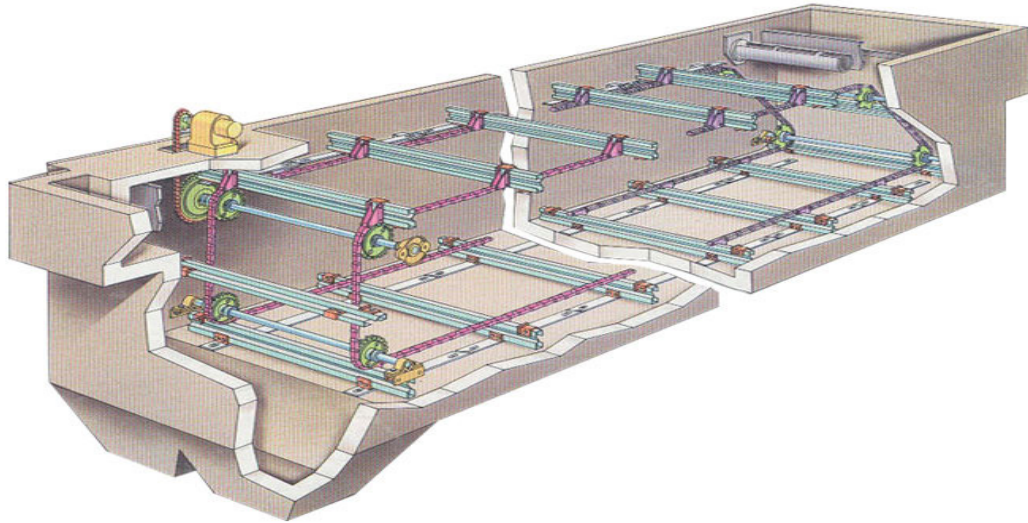

### ***Area and Volume***

- **AREA** ( a flat space or surface)
- **VOLUME** (the size of a 3-dimensional object or region of space, quantity)

**Area** is a two-dimensional measurement that in a rectangle involves the length and width of whatever is being measured. When the calculation is completed the answer will be in square feet (ft<sup>2</sup>). If we need to determine the cross-sectional area of a circle to determine flow rate or velocity we can do so by multiplying the diameter in feet times the diameter in feet by .785. The answer obtained by using this formula will also be in square feet (ft<sup>2</sup>).

**Volume** is a three-dimensional measurement that in a rectangle includes the depth measurement and in a cylinder (a circle with height or depth) includes the height or depth of whatever is being measured. The calculation of volume will result in an answer in cubic feet (ft<sup>3</sup>).



<b>OBJECT</b>	<b>AREA (ft<sup>2</sup>)</b>	<b>VOLUME (ft<sup>3</sup>)</b>
<b>Rectangle</b>	<b>Length' (ft) X Width' (ft)</b>	<b>Length' (ft) X Width' (ft) X Height'</b>
<b>Circle</b>	<b>.785 X D' (ft) X D' (ft)</b>	
<b>Triangle</b>	<b>½ (base' (ft) X altitude' (ft))</b>	
<b>Cylinder</b>		<b>.785 X D' (ft) X D' (ft) X Length' (ft)</b>
<b>Sphere</b>		<b>.5236 X D' (ft) X D' (ft) X D' (ft)</b>

**Diameter (D) = 2 X radius    Circumference = 3.14 (π) X Diameter    Perimeter = sum of all sides**

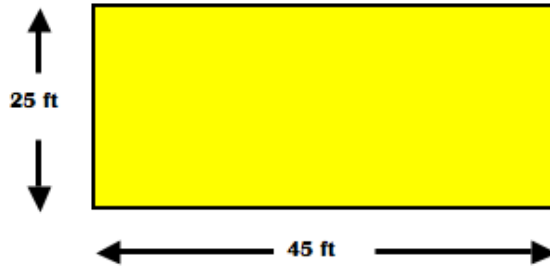

This rectangle measures 25 feet wide and 45 feet long. To calculate the area of this rectangle we multiply the width (25 feet) by the length (45 feet) and the sum will be in square feet. (ft X ft)

$$25' \text{ (ft)} \times 45' \text{ (ft)} = 1125 \text{ ft}^2 \text{ (square feet)}$$

In the calculations of circles or cylinders we use .785 in place of *pi* (3.14) which was and still is used. The number .785 was derived from figuring the area occupied by a circle inside a square which is .785 of the square

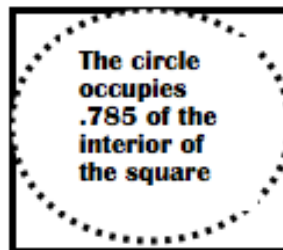

To calculate the area of a circle the sum will be the area inside the perimeter of the circle. To accomplish this we multiply diameter in feet times the diameter in feet times .785 and the sum will be in square feet.

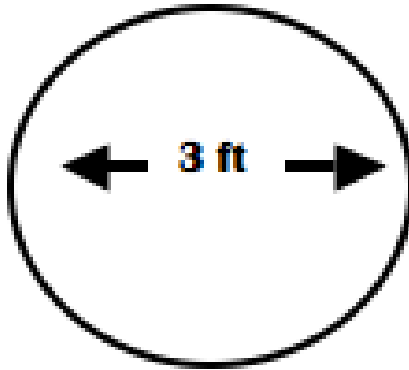

The diameter of this circle is three feet. To obtain the area inside of this circle we multiply the diameter in feet times the diameter in feet times .785.

$$.785 \times 3' (\text{ft}) \times 3' (\text{ft}) = 7.065 \text{ ft}^2 (\text{square feet})$$

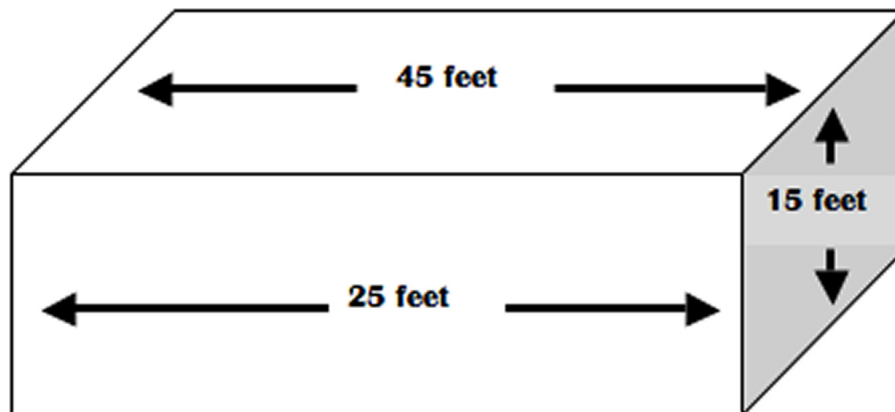

In this rectangle we have added the third dimension or measurement (15 feet). The sum of our calculation now will be in cubic feet (ft<sup>3</sup>) or feet times feet times feet.

$$\text{Volume} = 45' (\text{ft}) \times 25' (\text{ft}) \times 15' (\text{ft}) = 16,875 \text{ ft}^3 (\text{cubic feet})$$

We'll use the same size circle we used previously, but this time we will add the third dimension or measurement to it to determine how much space is in the cylinder.

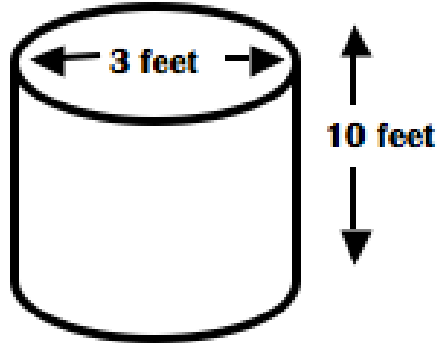

$$\text{Volume} = .785 \times 3' \text{ (ft)} \times 3' \text{ (ft)} \times 10' \text{ (ft)} = 70.65 \text{ ft}^3 \text{ (cubic feet)}$$

Since we don't frequently use cubic feet as an expression of volume relative to water we will frequently convert cubic feet to gallons by multiplying cubic feet by 7.48 to convert to gallons.

Many times the measurements we use aren't in whole feet. In that case we will need to convert inches to feet. To convert inches to feet just divide the inch measurement by twelve (12) which is obviously the amount of inches contained in a foot.

- 2" (inches) ÷ 12" (inches) = 0.166 ft
- 4" (inches) ÷ 12" (inches) = 0.25 ft
- 6" (inches) ÷ 12" (inches) = 0.50 ft
- 8" (inches) ÷ 12" (inches) = 0.66 ft
- 10" (inches) ÷ 12" (inches) = 0.83 ft
- 30" (inches) ÷ 12" (inches) = 2.5 ft

***Practice Problems***

1. What is the cross-sectional area of a 6 inch waterline?
2. You need to replace the carpet in the shop. It measures 14 feet wide by 22 feet long. How many square feet of carpet will you need to buy?
3. The new distribution line from the plant is 36 inches in diameter. What is the cross-sectional area of the new 36 inch line?
4. The sedimentation basin in your plant measures 15 feet wide, 40 feet long and it is 10 feet deep. What is the volume of your sedimentation basin in cubic feet and gallons?
5. Due to pressure issues a skid mounted tank is being installed that measures 20 feet in diameter and 60 feet in height. What is the volume in cubic feet and gallons of water that will be needed to fill this tank?

**Answers to Practice Problems**

1. To determine the cross-sectional area of a 6 inch waterline

**Area = .785 X .5 ft X .5 ft = 0.196 ft<sup>2</sup>**

2. To determine the area of the shop

**Area = 14 ft X 22 ft = 308 ft<sup>2</sup>**



3. To determine the area of a 36 inch pipe

**Area = .785 X 3 ft (36 inches ÷ 12 inches) x 3 ft (36 inches ÷ 12 inches) = 7.06 ft<sup>2</sup>**

4. To determine the volume of your sedimentation basin

**Volume = 15 ft X 40 ft X 10 ft = 6000 ft<sup>3</sup> 6000 ft<sup>3</sup> X 7.48 gallons = 44880 gallons**

5. To determine the volume of the temporary tank

**Volume = .785 X 20 ft X 20 ft X 60 ft = 18,840 ft<sup>3</sup> 18,840 ft<sup>3</sup> X 7.48 gallons = 140,923.2 gal.**

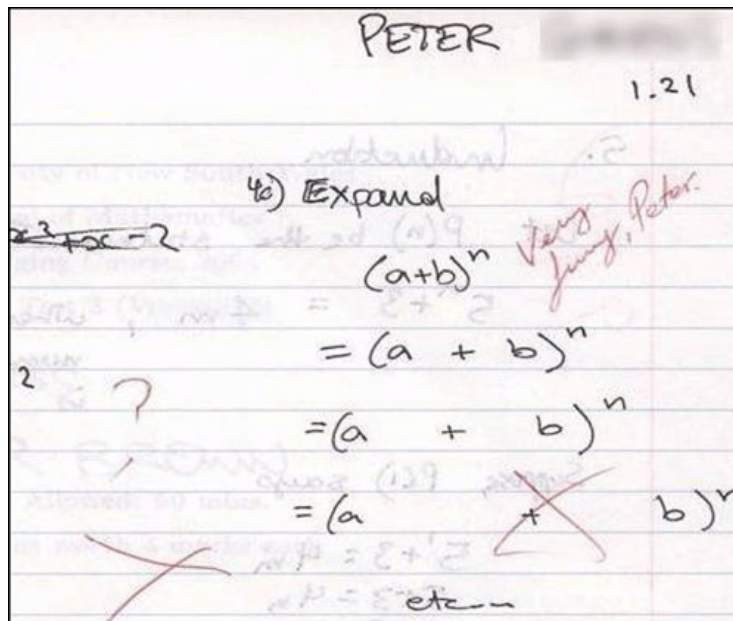

***Review Questions for Chapter 6 – Sedimentation***

1. Most of the sludge should settle out in the \_\_\_\_\_ of the sedimentation process.
2. Name four factors which can influence the success of the sedimentation process.
3. Name the four zones of a sedimentation basin.
4. An uneven velocity of flow through the sedimentation basin is referred to as \_\_\_\_\_.
5. Which type of basin, round or rectangular, are more susceptible to uneven flow velocities?
6. A relatively inexpensive way to add much more surface area for the particulate to settle out upon are called \_\_\_\_\_.

***Answers to Review Questions for Chapter 6 - Sedimentation***

1. First third
2. Any of these four will suffice, Particle size and distribution, shape of particles, density of particles, water temperature, dissolved substances, flocculation characteristics, environmental conditions, sedimentation basin hydraulic characteristics.
3. Inlet, settling, sludge, outlet
4. short circuiting
5. circular
6. tube settlers

This page left blank intentionally.



# Chapter 7: ALTERNATIVE TREATMENT PROCESSES

## Chapter 7 Objectives

1. Define upflow clarification in relation to solids contact units and explain how these type of units work.
2. Determine the degree of operator diligence required to successfully operate a solids contact unit as opposed to conventional treatment.
3. List the visible indicators that could signify the successful operation of an upflow clarifier or solids contact unit.
4. Determine the advantages and/or disadvantages, if any, of upflow clarification in comparison with conventional treatment.
5. Demonstrate the ability to calculate weir overflow rates and detention time, lbs. and concentration of chemical additions.
6. Determine what the significant difference is between conventional treatment and the operation of Actiflo treatment processes.
7. Explain the operation of a DAF unit as opposed to conventional treatment.
8. Explain the operation of Pulsators and Super Pulsators and how they differ from conventional treatment in what way?
9. Explain the operation of a Trident Microfloc unit and how it differs from conventional treatment.
10. Explain the operation of a Roberts Filter Group unit and how it differs from conventional treatment.
11. Determine how membranes accomplish their task, the four types used in water treatment and their differences, advantages and disadvantages between each other and conventional treatment.

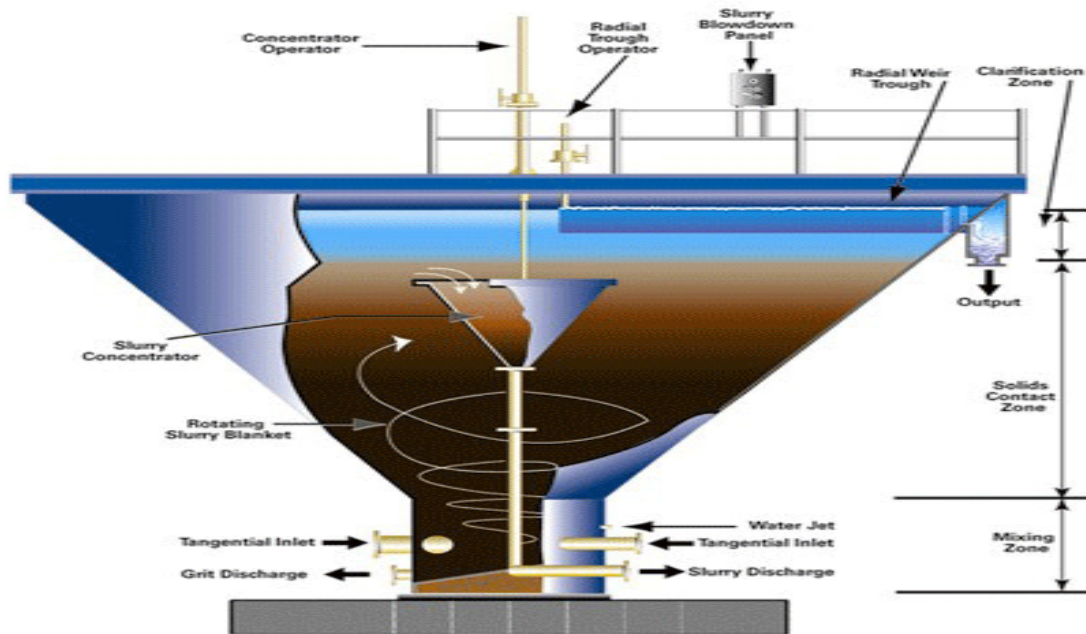

### ***Solids Contact Units***

Solid contact units, or as they are sometimes called, upflow clarifiers or Claricones (Claricone is a brand name) are circular, vertical flow, basins that combine the coagulation, flocculation, and sedimentation processes in the same basin. Some solids contact units are built to involve only clarification.

Flow is in an upward direction and through a sludge blanket or slurry of flocculated suspended solids. This sludge blanket, which must be constantly monitored and maintained at a certain level and density, acts as a coagulant aid increasing the effectiveness of the process of particulate removal.

### ***Process Control***

#### **Flow Rate**

- The design flow rate needs to be converted to an overflow rate. For each overflow rate there is an optimum slurry level and density that needs to be maintained.
- A rising overflow rate will increase the depth of the slurry without increasing its volume or density.
- A decrease in the overflow rate will reduce the amount of slurry, without changing its volume.

- Sample taps will enable the operator to monitor changes in slurry depth and concentration.
- Frequent monitoring of the rise and fall of the slurry level allows the operator to promptly make adjustments in the recirculation device and more stringently control the rate of flow changes. This method of operation will work only with gravity flow systems. Pressure systems are very difficult to control with changing flow rates.

### **Turbidity Level**

- The operator must immediately recognize changes in the raw water turbidity and know exactly what to do when these changes occur in the clarifier so chemical dosages can be adjusted accordingly. Higher turbidity levels mean higher dosages will be necessary.

### **Water Temperature**

- Changes in water temperature causes changes in water density which influences particle settling rates.
- In extremely cold water, the operator might consider using polymers, activated silica, calcium carbonate or some other weighing agent to aid in the sedimentation process.
- Solar heat will cause a certain amount of carryover to occur. This is natural and doesn't warrant serious concern as long as the major portion of the sludge blanket stays in the settling zone and overall turbidity meets your objectives.

### **General**

- Dramatic changes in flow rates and temperature make the process very difficult to control.
- If the slurry rises to the weirs and is carried over to the filters, reduce the flow rate. If possible, use weighing agents before changing flow rates in cold water. However, the use of weighing agents can cause problems with the slurry, requiring changes in recirculation rates but too high of a recirculation rate may also cause the slurry to flow over into the filters.
- Ample care should be taken when changing flow rates during a (cold water) temperature change.

## ***Operational Fundamentals***

The operator of a solids contact unit controls the performance of the unit by adjusting three variables: 1) Chemical dosage, 2) Recirculation of slurry and 3) Sludge control.

### ***Chemical Dosage***

There must always be sufficient alkalinity in the raw water to react with the coagulant. Example: for every mg/L of alum that is added, 0.45 mg/L of bicarbonate alkalinity is required to complete the chemical reaction. In order for precipitation to occur there should be an excess of 20 mg/L of alkalinity present. Alkalinity levels can be increased with the addition of lime, caustic soda, or soda ash.

Proper chemical dosages must be obtained through some means and jar testing is the most viable method. We want to use the dosage that produces the best floc and the lowest turbidity within a five minute settling period after stopping the jar stirrers. The jar test stirrer speed and stirring time should as closely as possible approximate the conditions of the recirculating reaction zone of the clarifier.

### ***Recirculation of Slurry***

The recirculation rate is established by the speed of the impeller, turbine, pumping unit or by the injection of air. There is a direct relationship between the percentage of slurry present and the mixing speed. To control this process, the operator must maintain the correct volume of slurry in the reaction zone by controlling the rate of recirculation. Keeping a log of the speed (RPM) of the recirculating device will be beneficial and allow the operator to perform calculations of the percentage of slurry using the volume over volume test.

$$V/V\% = \frac{(\text{settled slurry ml}) (100)}{\text{total sample volume, ml}}$$

The clarity of the water above the slurry (the supernatant) will indicate how well the chemical reaction is proceeding. The percentage of solids by volume will indicate whether a proper amount of slurry is in the reaction zone. This analysis should be performed at least hourly and even more often when the raw water is changing frequently. Experience in this task as well as good recordkeeping will allow an operator to determine the optimum percentage of solids to maintain.

### ***Sludge Control***

The sludge accumulates on the bottom of the clarifier in the settling zone. The sludge is removed hydraulically through a control valve. The Volume/Volume Test can be used to determine the proper time to waste the sludge. The sludge being discharged should be 90 – 98% solids. If the sludge being discharged is less than 90% solids, a considerable amount of water is being pumped that could result in not leaving enough sludge to be recirculated in the reaction zone. If the percentage of solids is too high then too much sludge could be accumulating and the recirculation device could become overloaded.

### ***Comparison with Conventional Rectangular Basins***

#### **Advantages**

Solid contact units provide better performance in turbidity removal and softening, under ideal operating conditions; chemical requirements are generally higher for turbidity removal and lower for softening processes. Since the entire process is in one basin, capital and maintenance costs are usually lower than in conventional treatment. If taste and odor issues are present, activated carbon can be added to the sludge blanket to provide effective treatment. During algal blooms when coagulants fail to react properly because of changes in pH, alkalinity, carbonate, and dissolved oxygen, treatment is more easily controlled. The operator can increase the amount of slurry available during favorable treatment conditions and remove it during periods when the coagulation process is not functioning well.

#### **Disadvantages**

Extremely unstable during rapid changes in flow rate, turbidity level, and temperature. Solids contact units require a higher level of operator knowledge, skill, and diligence. Solids contact units are more susceptible to short-circuiting than conventional treatment.

## Summary

With increased speed of the recirculating device, a larger amount of slurry can be retained in the unit. At the same time, if this amount of slurry becomes too great, it may cause the sludge blanket to rise and ultimately spill over the effluent weirs with the treated water.

If the recirculation rate is too low, the solids may settle too soon with enough recirculation and will not return to the reaction zone. The absence of solids in the reaction zone will result in improper coagulation. The end effect is a failure of the treatment process.

Experience will allow the operator to determine the optimum amount of slurry needed to be present that will satisfy a given recirculation rate, coupled with proper chemical dosage and a sufficient percentage of solids for recycling.

In order to calculate the viability of the operator's efforts with a solids contact or upflow clarifier the need exists to be able to calculate the weir overflow rate.

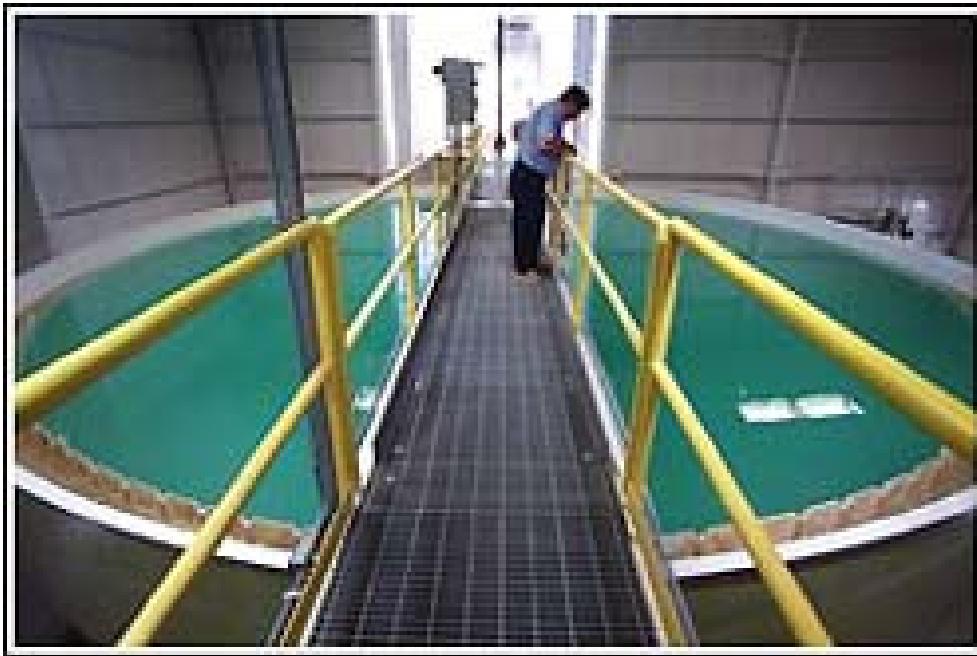

***Weir Overflow Rate***

$$\text{Weir Overflow Rate (WOR)} = \text{GPM} \div \text{Feet of Weir}$$

$$\text{Circumference} = 3.14 \times \text{Diameter (ft)} \quad \text{Perimeter} = \text{sum of all sides}$$

**Franklin treats 3.5 MGD and their upflow clarifier has a diameter of 35 feet. What is the weir overflow rate?**

$$\text{WOR} = (3.5 \text{ MG} \times 694.5 \text{ gpm}) \div (3.14 \times 35 \text{ ft})$$

$$\text{WOR} = 2430.75 \text{ gpm} \div 109.9 \text{ ft}$$

$$\text{WOR} = 22.11 \text{ gpm/ft of weir}$$

***Detention Time***

$$\text{Detention Time (DT)} = \text{Volume (gals)} \div \text{Flow (gpm)}$$

**Murphy's sedimentation basin measures 18 feet by 45 feet and the water depth in the basin is 8 feet and they treat 1.2 MGD. What is Murphy's detention time in hours?**

$$\text{DT} = \text{Volume (gallons)} \div \text{Flow (gpm)}$$

$$\text{DT} = (18' \times 45' \times 8' \times 7.48 \text{ gallons}) \div (1.2 \text{ MG} \times 694.5 \text{ gpm})$$

$$\text{DT} = 48470.4 \text{ gallons} \div 833.4 \text{ gpm}$$

$$\text{DT} = 58.16 \text{ minutes}$$

$$\text{DT} = .97 \text{ hours ( } 58.16 \text{ minutes} \div 60 \text{ minutes)}$$

***Surface Overflow Rate***

$$\text{Surface Overflow Rate (SOR)} = \text{Flow (gpm)} \div \text{Area (square feet)}$$

This is computed exactly the same way that filtration rates and backwash rates are computed. Knotville treats 785,000 GPD and the size of their clarifier is 15 feet by 20 feet. What is their surface overflow rate?

$$\text{SOR} = (785,000 \text{ gallons} \div 1,000,000) \times 694.5 \text{ gpm} \div (15 \text{ ft} \times 20 \text{ ft})$$

OR

$$\text{SOR} = (785,000 \text{ gallons} \div 1440 \text{ minutes}) \div (15 \text{ ft} \times 20 \text{ ft})$$

$$\text{SOR} = 545 \text{ gpm} \div 300 \text{ ft}^2$$

$$\text{SOR} = 1.82 \text{ gpm/ft}^2$$

In order to determine the correct dosage of the chemicals needed to successfully treat our water we need to be able to compute both the pounds necessary to complete our tasks and the dosage in ppm needed to optimize treatment.

***Lbs of Chemical***

$$\text{Lbs. of chemical} = \text{ppm} \times 8.34 \times \text{MG}$$

$$\text{ppm} = \frac{\text{Lbs. of chemicals}}{8.34 \times \text{MG}}$$

**Anderson County treats their water by adding 4 ppm of cationic polymer to a flow of 3.5 MGD. How many pounds of polymer does Anderson County add to their water?**

$$\text{Lbs.} = \text{ppm} \times 8.34 \times \text{MG}$$

$$\text{Lbs.} = 4 \text{ ppm} \times 8.34 \times 3.5 \text{ MGD}$$

$$\text{Lbs.} = 116.8$$



**Flemingwood adds 800 lbs. of lime in order to treat a flow of 4167 gpm. What is Flemingwood's dosage in ppm?**

$$\text{ppm} = \frac{\text{Lbs. of chemical}}{8.34 \times \text{MG}}$$

$$\text{ppm} = \frac{800 \text{ lbs.}}{8.34 \times (4167 \div 695.5 \text{ gpm})}$$

$$\text{ppm} = \frac{800 \text{ lbs.}}{8.34 \times 6 \text{ MG}}$$

$$\text{ppm} = \frac{800 \text{ lbs.}}{50}$$

$$\text{ppm} = 16$$

***Practice Problems***

1. Henderson treats 2.75 MGD and its clarifier has a radius of 35 feet. What is the weir overflow rate?
2. Evansboro has a sedimentation basin that measures 16 feet wide by 40 feet long and the water depth is 10 feet and they treat 6.2 MGD. What is Evansboro's detention time?
3. Pudducat rectangular weir measures 20 feet wide and 40 feet long. The plant treats 9,000,000 gallons per day. What is the surface overflow rate?
4. Prestonsville uses 2.2 ppm of bentonite clay as a weighing agent to treat a flow of 8 MGD. The desired dosage is 3.5 ppm. How many additional lbs. per hour of bentonite clay will be needed?
5. The new operator used 600 lbs. of polymer to treat Flatfoots flow of 1.8 MGD. What is the dosage of polymer at the plant?

***Solutions to Practice Problems***

**1)** WOR = Flow (gpm) ÷ Feet of weir

$$\text{WOR} = (2.75 \text{ MGD} \times 694.5 \text{ gpm}) \div (2 \times 35 \text{ ft } \mathbf{radius}) \times 3.14$$

$$\text{WOR} = 1910 \text{ gpm} \div 220 \text{ ft}$$

$$\text{WOR} = 8.7 \text{ gpm/ft of weir}$$

**2)** DT = Volume (gals) ÷ Flow (gpm)

$$\text{DT} = (16 \text{ ft} \times 40 \text{ ft} \times 10 \text{ ft}) \times 7.48 \text{ gallons} \div (6.2 \times 694.5 \text{ gpm})$$

$$\text{DT} = 47872 \text{ gallons} \div 4306 \text{ gpm}$$

$$\text{DT} = 11.11 \text{ gpm/ft of weir}$$

**3)** SOR = Flow (gpm) ÷ Area (ft<sup>2</sup>)

$$\text{SOR} = (9,000,000 \div 1440 \text{ minutes}) \div (20 \text{ feet} \times 40 \text{ feet})$$

OR

$$\text{SOR} = (9 \text{ MG} \times 694.5 \text{ gpm}) \div (20 \text{ ft} \times 40 \text{ ft})$$

$$\text{SOR} = 6250 \text{ gpm} \div 800 \text{ ft}^2$$

$$\text{SOR} = 7.8 \text{ gpm/ft}^2$$

4) Lbs. = ppm X 8.34 X MG

Lbs. = (3.5 ppm wanted – 2.2 ppm already applied) X 8.34 X 8 MGD

Lbs. = 1.3 ppm X 8.34 X 8 MGD

Lbs. = 86.74 lbs/day

Lbs. = 86.74 lbs ÷ 24 hours

Lbs. = 3.6 lbs./hr

5) ppm =  $\frac{\text{lbs. of chemical}}{8.34 \times \text{MG}}$

8.34 X MG

ppm =  $\frac{600 \text{ lbs.}}{8.34 \times 1.8 \text{ MG}}$

8.34 X 1.8 MG

ppm =  $\frac{600 \text{ lbs.}}{15}$

15

ppm = 40

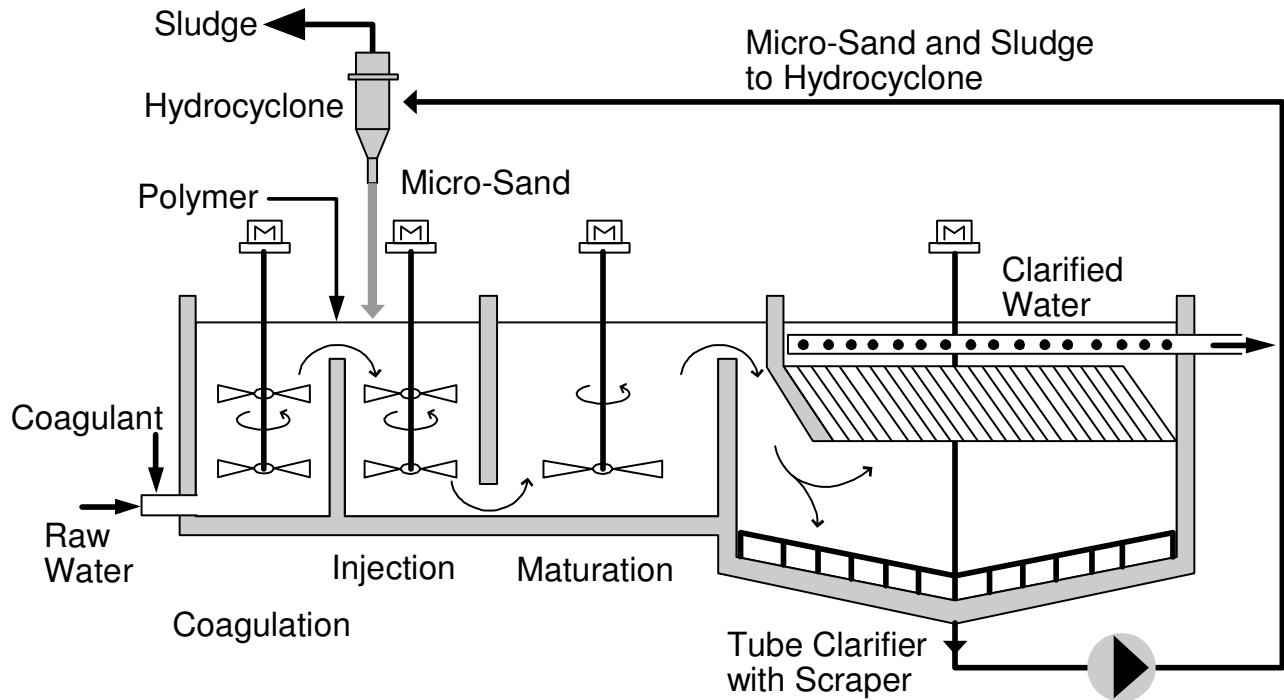
**Actiflo**

Actiflo is a treatment system that combines micro-sand with the floc particles to accomplish treatment much more rapidly than conventional treatment.

1. Raw water enters the flash mix and is combined with coagulants. (1 minute\*)
2. The water then enters the injection tank where micro-sand and polymers are mixed in the water. (1 minute\*)
3. The water then enters the maturation zone where it is more gently mixed with a longer retention time which allows the floc to get larger and settle faster. (4 minutes\*)
4. Next, the water enters the settling tank where the micro-sand ballasted floc settles out almost immediately. (6 minutes\*)

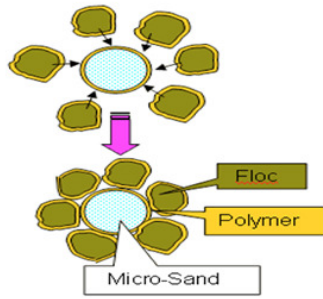

5. The water then flows up through the settling tubes (lamella clarifiers) to the collection troughs. (4 minutes\*)
6. The micro-sand ballasted sludge is pumped from the bottom of the settling tank into a hydrocyclone where the sludge and sand are separated and the sand is reused. (The entire process takes form 10 to 20 minutes) \* all times are approximate



sand pumps



hydrocyclones

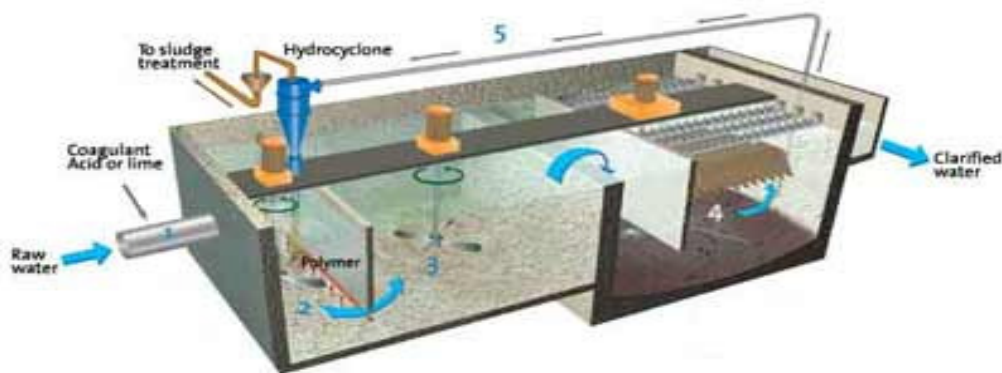



Actiflo as well as Clari-DAF, Trident Micro-Floc, Infilco's Pulsator, and Reynolds Filter Group treatment processes can be brought in on a flat bed truck, plumbed and wired and begin treating water.

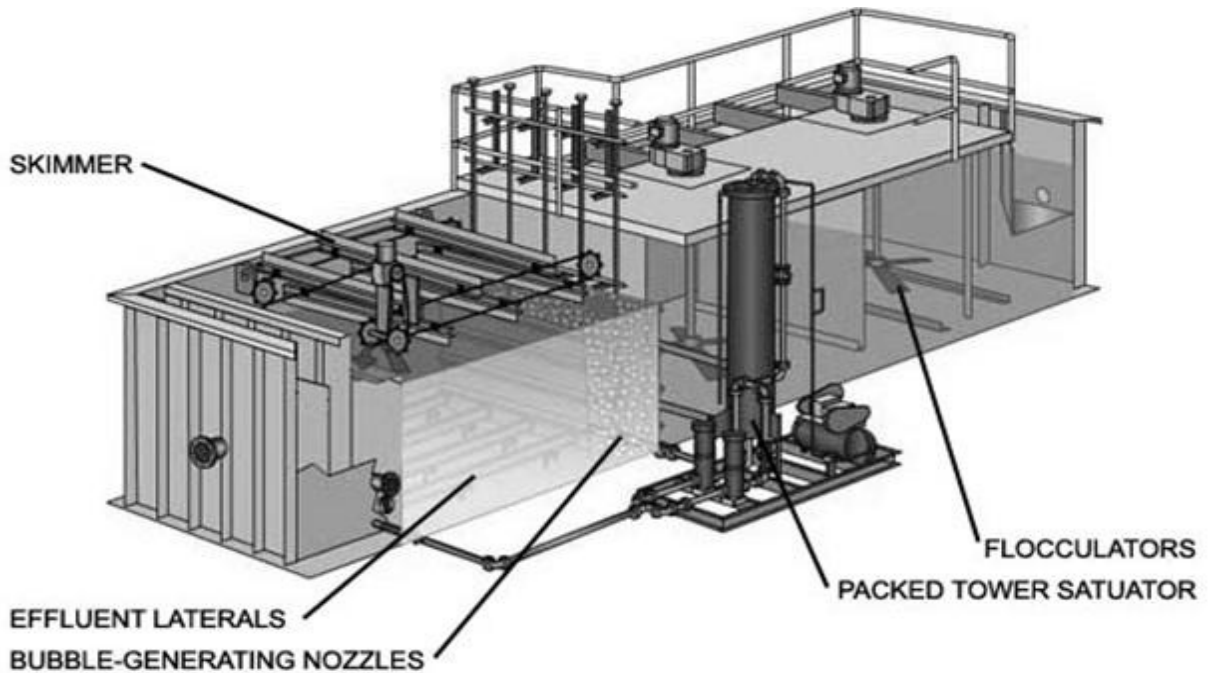

**CLARI-DAF by Leopold**

### **Raw Water Inlet**

Coagulated water from an in-line rapid mixer enters a flow distribution channel prior to the flocculation zone.

### **Flocculation zone**

Coagulated water is equally split to each unit, with traditional 2-stage tapered energy flocculation with variable frequency mixers. The retention time employed in this stage is generally between eight and ten minutes.

### **Air – Water Dispersion Zone**

Flocculated water is then base of the flotation zone, through the injection of a recycle stream. The recycle stream is produced by recycling 8 – 12 % of the clarified or filtered water to a pressurized saturator vessel (70-90 psi). The recycle stream is the depressurized through a series of release submerged and span the entire transition zone that then create micro-bubbles which disperse zone.

### **Flotation Zone**

The principle behind the flotation process is the micro-bubbles which will form a dense air blanket within the flotation zone. This flocculated particulate will agglomerate with the micro- bubbles as they rise to the surface and subsequently, clarify the water.

### **Sludge Accumulation**

The floating solids accumulate on the surface of the Aqua DAF unit that result in a thick sludge layer. Sludge can then be removed by one of two methods:

1. Hydraulically, an automatic effluent weir rises at a prescribed time. Subsequently, the flotation zone water inlet rises and the sludge is removed to a sludge trough .
2. Mechanically, a traveling sludge scraper penetrates and scrapes the sludge layer into the sludge trough.



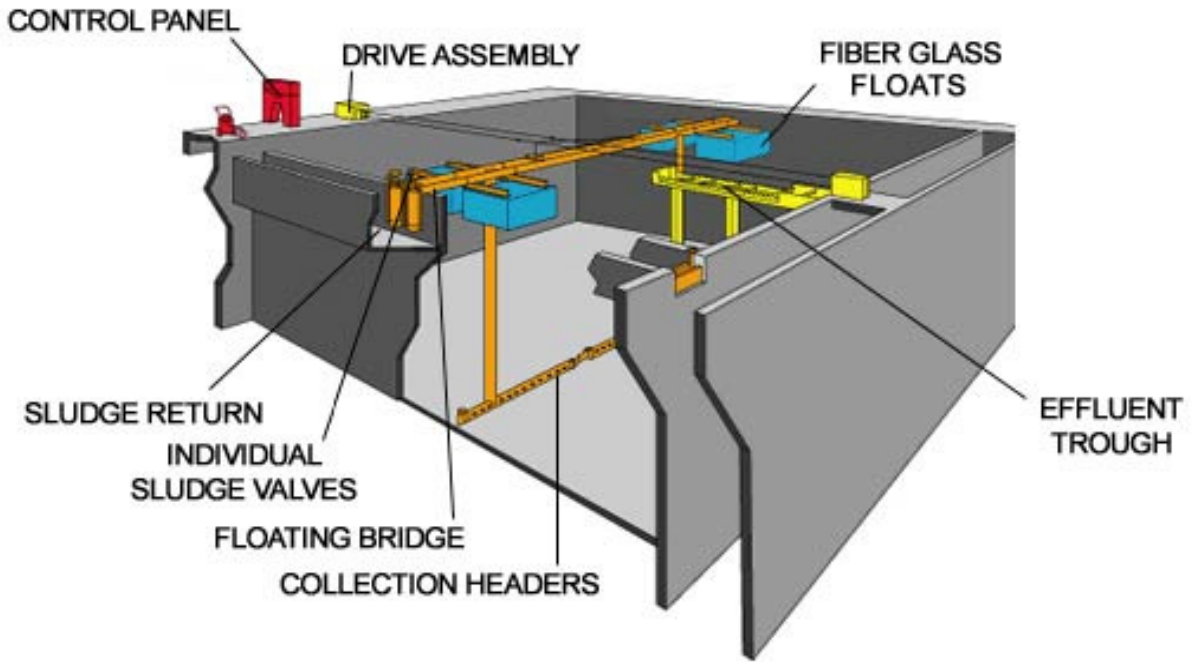

### 3D View

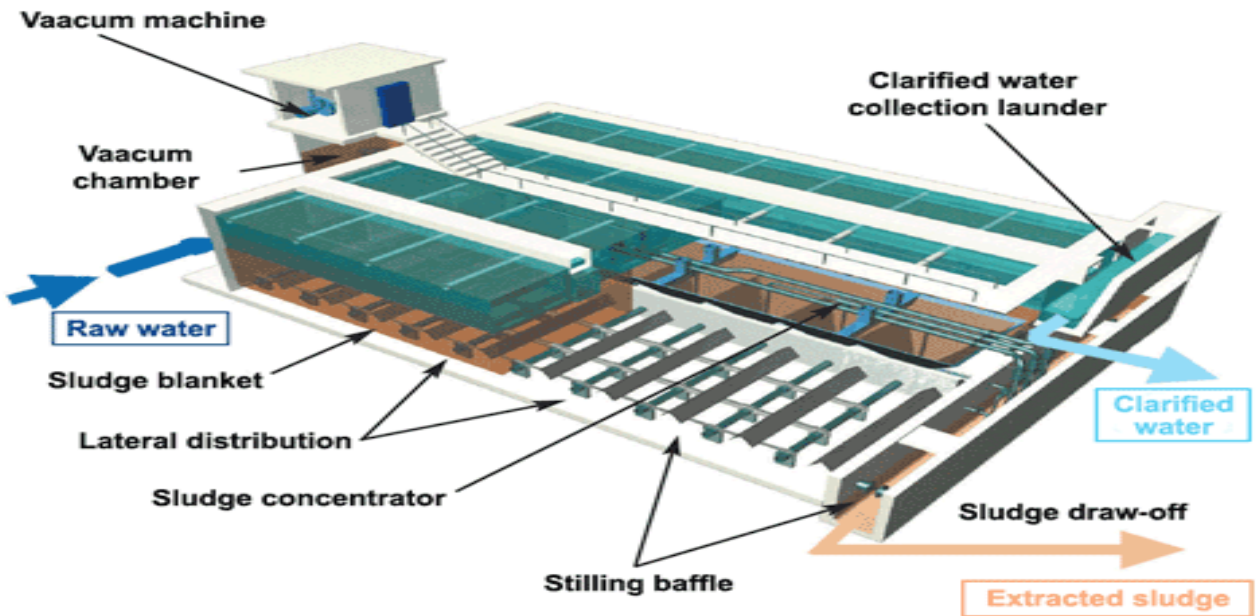

## ***Pulsators and Super Pulsators***

### **Operation**

1. Coagulated water from the rapid mix is sent to the pressure or vacuum chamber.
2. This coagulated water is distributed to a series of laterals that point downward in order to promote scouring of the basin floor and provide energy for flocculation.
3. Internal sludge concentrators have headers that are opened at prescribed intervals and allow the sludge to be removed by gravity.
4. Flocculated water is then directed upward through fiberglass settling plates while a 10 foot sludge blanket is maintained.
5. Clarified water is collected across the length of the settling area to a center collection trough.
6. At a prescribed frequency and duration, the vent valve atop the chamber opens and closes thereby creating subtle pulsations of the sludge blanket.
7. The net result is a pulsing sludge blanket that combines flocculation, clarification (settling), and sludge collection into one compact system.

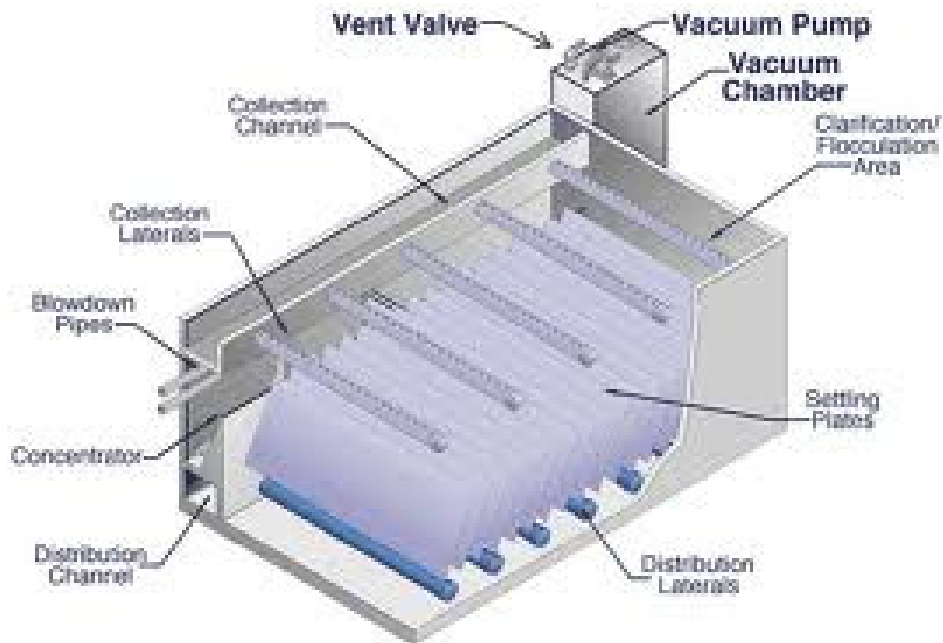

## Trident Microfloc

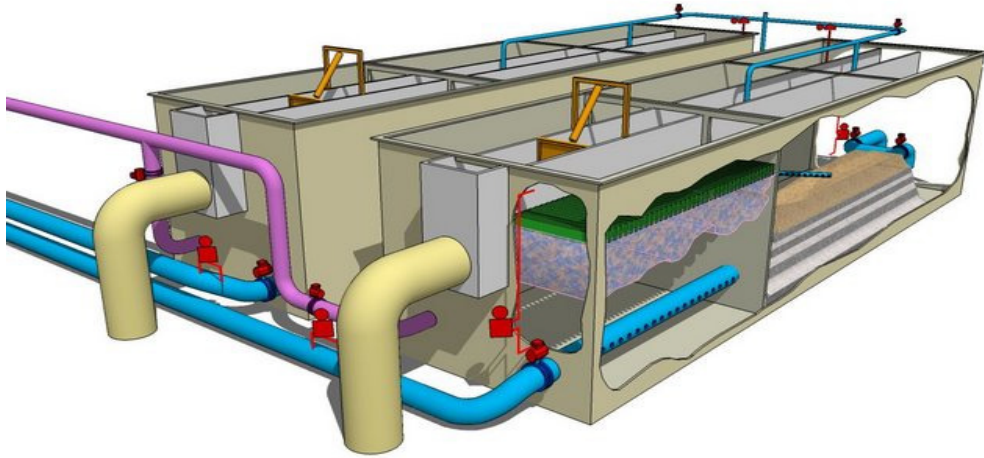

### Operation

1. First, the water enters a minimum of two 60° inclined tube settlers. In this process, sludge recirculation enhances the solids removal process.
2. Next, the water enters an upflow process that combines flocculation and clarification (settling) in a single process. This adsorption clarification media does not form floc that can settle but rather uses a buoyant media.
3. After the clarification process, the water flows through a 30" deep mixed media (typically anthracite, sand and garnet) which becomes progressively finer from top to bottom

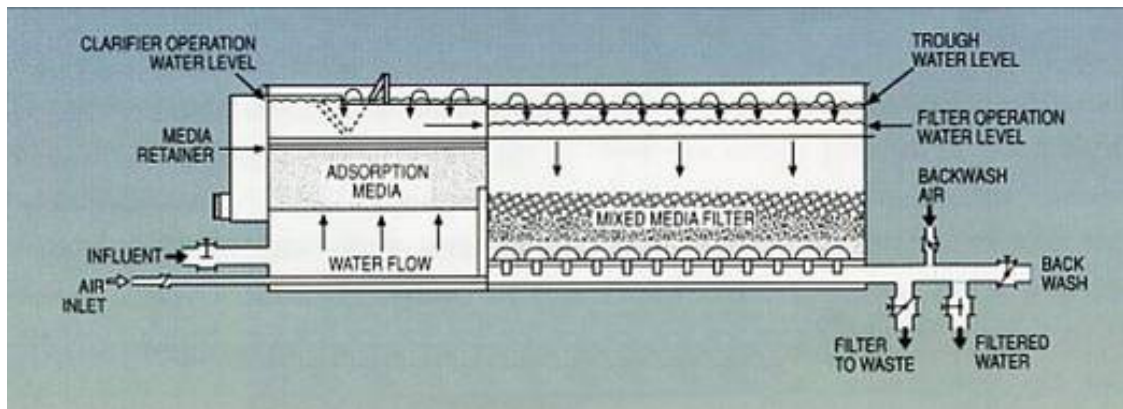

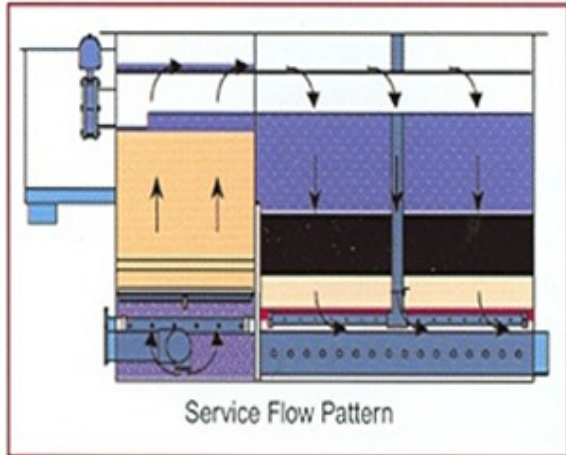
***Roberts Filter Group - Pacer***

The first stage, or pretreatment section, is the ContaClarifier©. It is of granular, non-buoyant media bed that is stable under all service flow conditions. Chemically dosed water is introduced to the bottom of the clarifier section and flows upward through the bed. The flow around the irregularly shaped media particles causes the intimate mixing and interparticle collisions needed for the process of floc formation. The flocculation process is enhanced by contact with the previously retained solids.

ContaClarifier© bed washing can be activated manually or automatically at an elapsed time interval or, when headloss reaches a predetermined setpoint. Air agitation along with normal operational raw water upflow, scrubs the ContaClarifier© media. Raw water flow continues for a short period afterward, flushing the remaining solids to the waste line.

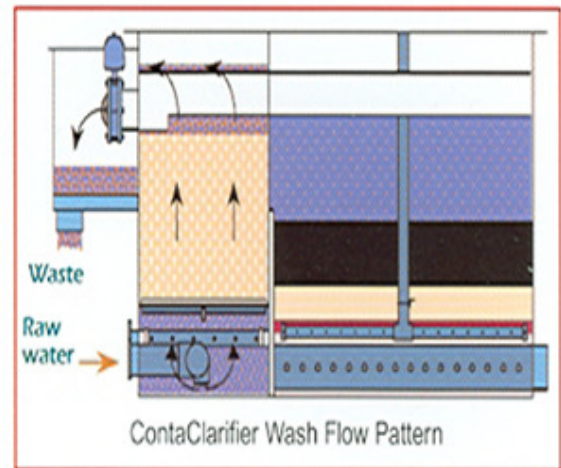

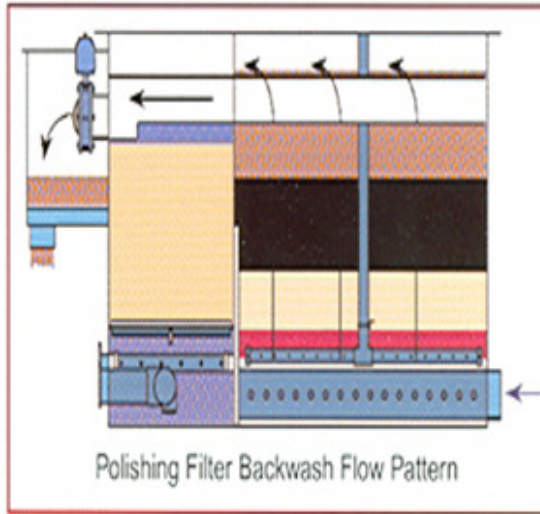

The backwash cycle incorporates a separate air wash step using the Aries™ Managed Air System for the most effective cleaning. The influent valve is closed and the filter is allowed to drain until the water level is about six inches above the filter media and the air system is turned on. The scouring action developed by the air system breaks the accumulated solids free from the filter media particles ensuring effective cleansing at a minimum backwash water use. The filter is air washed at about 2-3 ft<sup>3</sup>/ft<sup>2</sup> for 3-4 minutes.

The backwash flow is then established for refill and maintained for 5-8 minutes at a rate of at least 15-18 gpm/ ft<sup>2</sup>. Flow is then reestablished through the clarifier and the unit begins to filter to waste cycle. This continues for 5 - 10 minutes until the effluent turbidity is below acceptable limits. The total backwash cycle time is 20 - 30 minutes.

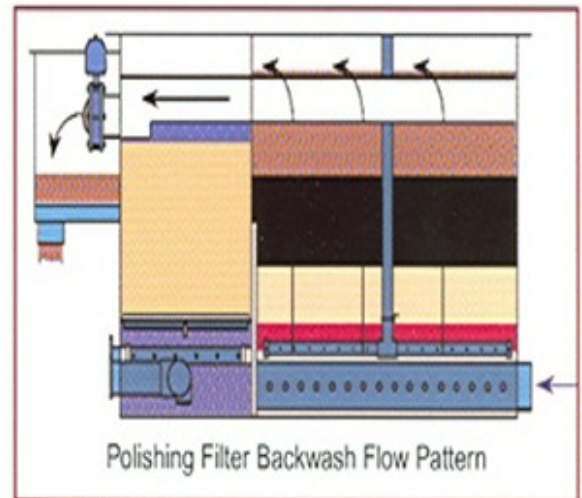

**Potentially Beneficial Characteristics:**

- Small footprint
- Pre-fabricated units
- Automated operation
- Frequently less expensive than conventional treatment facilities
- Some offer as much as 7 log removal of *Cryptosporidium*

***Membrane Filtration***

A membrane, or more succinctly described, a semi-permeable membrane is a thin piece of material capable of separating substances. Membrane processes have become more attractive for potable water treatment in recent years for many reasons. Some users like the fact that membranes size exclusion technology show great promise for meeting current as well as future regulations, including natural organic matter (NOM) which can impart color, tastes, odors, and in combination with chlorine can cause disinfection byproducts. Others enjoy the fully automated controls that can eliminate guesswork by the operator. The first membranes used in potable water were pressure driven, with vacuum driven membranes being used more and more frequently.

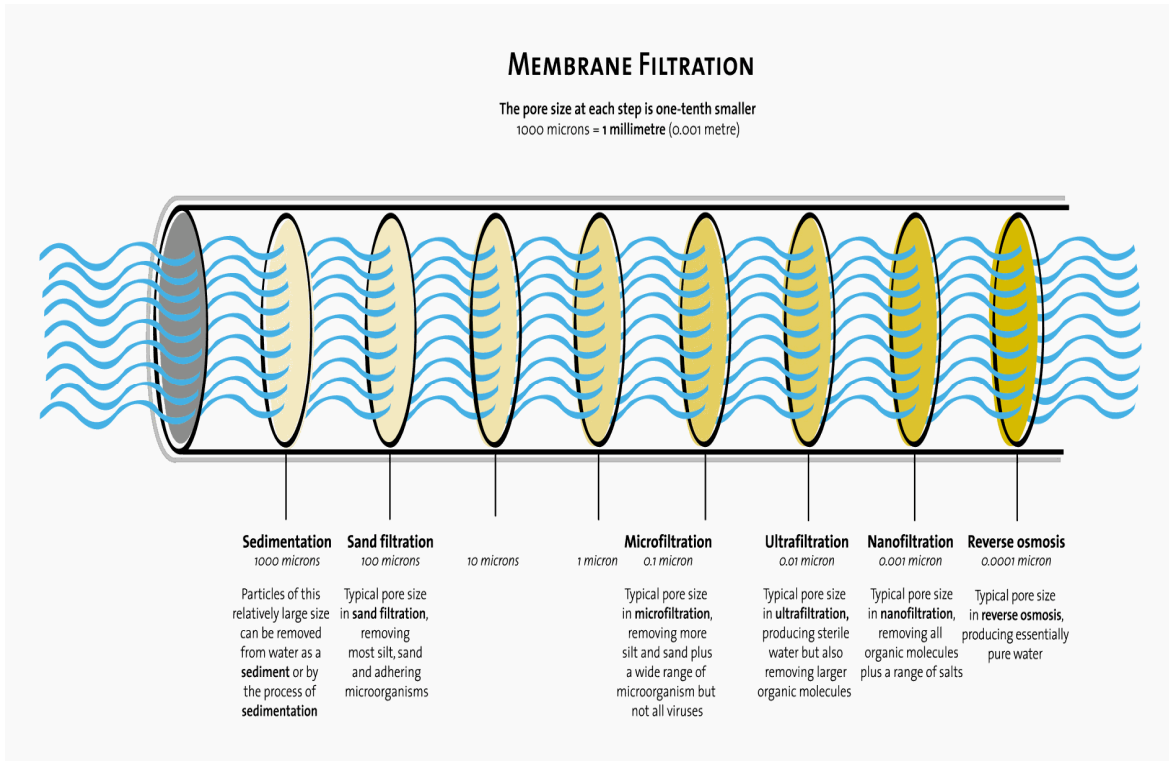

As the above illustration points out, sand filtration will effectively remove particles above the size of 100 microns. Some of the attraction to membrane filtration is garnered by the fact that some membranes remove particulate down to the size of 1/10,000 of a micron. The four types of membrane filtration used in water treatment are, by size of particulate exclusion from largest to smallest, microfiltration, ultrafiltration, nanofiltration, reverse osmosis.

How Big is a .0001 to a Piece of Hair ? (English Standard)  
How Big is a Micron to a Piece of Hair ? (Metric Standard)  
2,000 times size

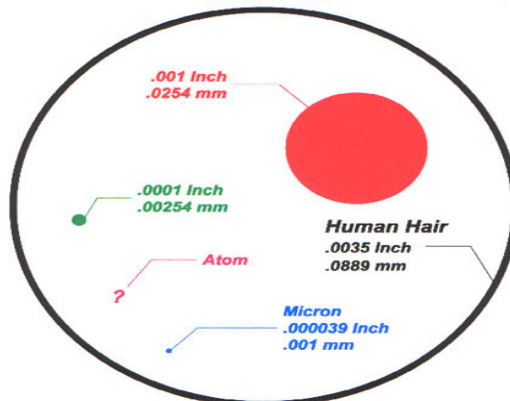

**DERICK**  
DIG GRINDING  
INCORPORATED  
Visual aid only

Another factor in determining the proper membrane for the correct application is the flux rate. In membrane applications, flux rate is pretty much synonymous with flow rate. There is a maximum amount of water that can pass over or through a membrane that will viably allow the water to be “filtered” so that size exclusion processes work the way we want them to.

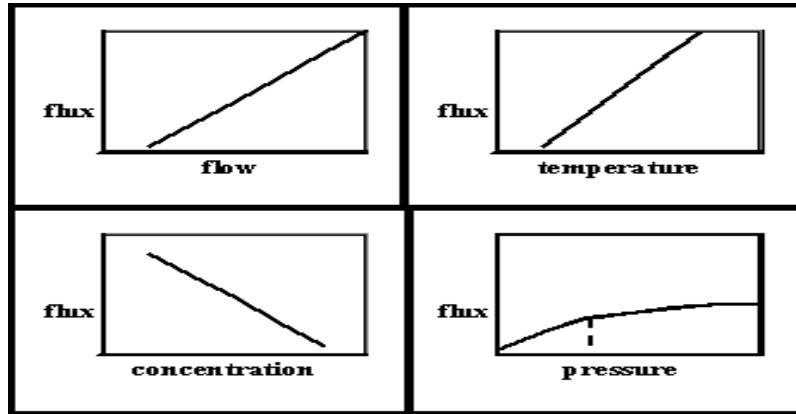

Again, there are four types of membrane filtration mentioned here:

***Surface Water Treatment Compliance Technology***

Unit Technologies	Removal: Log <i>Giardia</i> and Log Virus	Raw Water, Pretreatment & Other Water Quality Issues
<b>Microfiltration (MF)</b>	Very effective <i>Giardia</i> , > 5-6 log; Partial removal of viruses (disinfect for virus credit)	High quality influent or pretreatment required. Same note regarding TOC
<b>Ultrafiltration (UF)</b>	Very effective <i>Giardia</i> , > 5-6 log; Partial removal of viruses (disinfect for virus credit)	High quality influent or pretreatment required (e.g., MF). TOC rejection generally low, DBP precursors could be a concern



<b>Nanofiltration (NF)</b>	Very effective absolute barrier (cysts and viruses)	Very high quality influent or pretreatment required
<b>Reverse Osmosis (RO)</b>	Very effective absolute barrier (cysts and viruses)	May require conventional or other pretreatment for surface water to protect membrane surfaces: may include turbidity or Fe/Mn removal; stabilization to prevent scaling; reduction of dissolved solids or hardness; pH adjustment

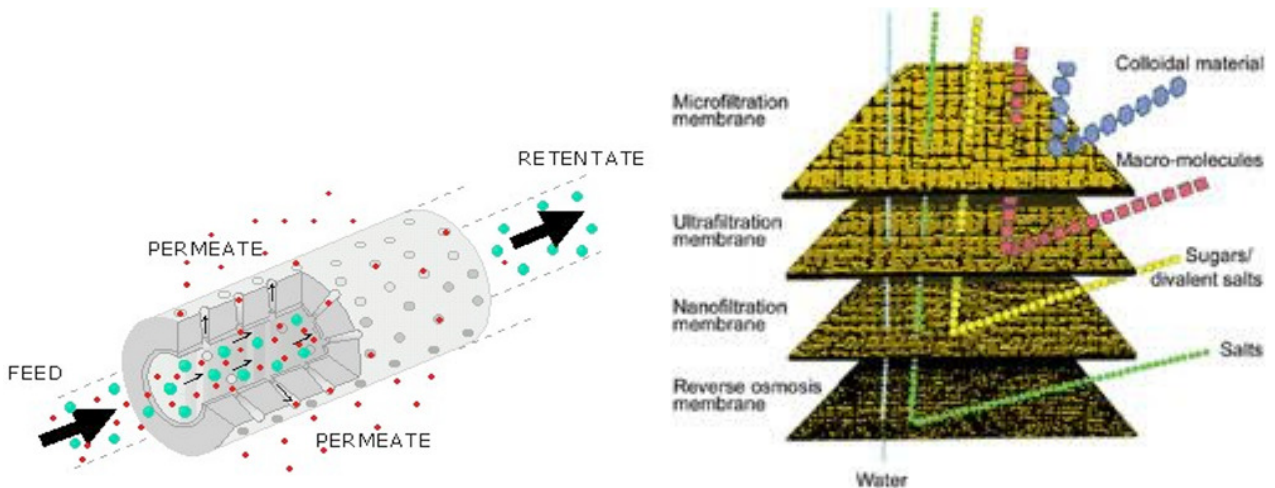

Most municipal membrane applications use micro or ultrafiltration membranes while many bottled water industrial applications seem to be reverse osmosis. Nanofiltration seems to be used more for process water.

### ***Membrane Filtration Comparison***

<b>Unit Technologies</b>	<b>Complexity: Ease of Operation (Operator Skill Level)</b>	<b>Secondary Waste Generation</b>	<b>Other Limitations/ Drawbacks</b>
<b>Microfiltration (MF)</b>	Basic: increases with pre/post treatment and membrane cleaning needs	Low volume waste, may include sand, silt, clay, cysts, and algae	Disinfection required for viral inactivation
<b>Ultrafiltration (UF)</b>	Basic: Increases with pre/post treatment and membrane cleaning needs	Concentrated waste: 5 – 20% by volume. Waste may include sand, silt, clays, cysts, viruses and humic material	Disinfection required for viral inactivation
<b>Nanofiltration (NF)</b>	Intermediate: increases with pre/post treatment and membrane cleaning needs	Concentrated waste: 5 – 20% by volume	Disinfection required under regulation, as recommended as a safety measure and residual protection.
<b>Reverse Osmosis (RO)</b>	Intermediate: increases with pre/post treatment and membrane cleaning needs	Brine waste. High volume, e.g., 25 – 50%. May be toxic to some species	Bypassing of water cannot be practiced at risk of increasing microbial concentrations in finished water. Post – disinfection required under regulation, is recommended as a safety measure and for residual maintenance



Initially, membranes used pumps to forcefully push water through the tiny openings or pores in the filters. The openings, in some cases, is so small that only water can pass through the pores in the membrane (reverse osmosis).

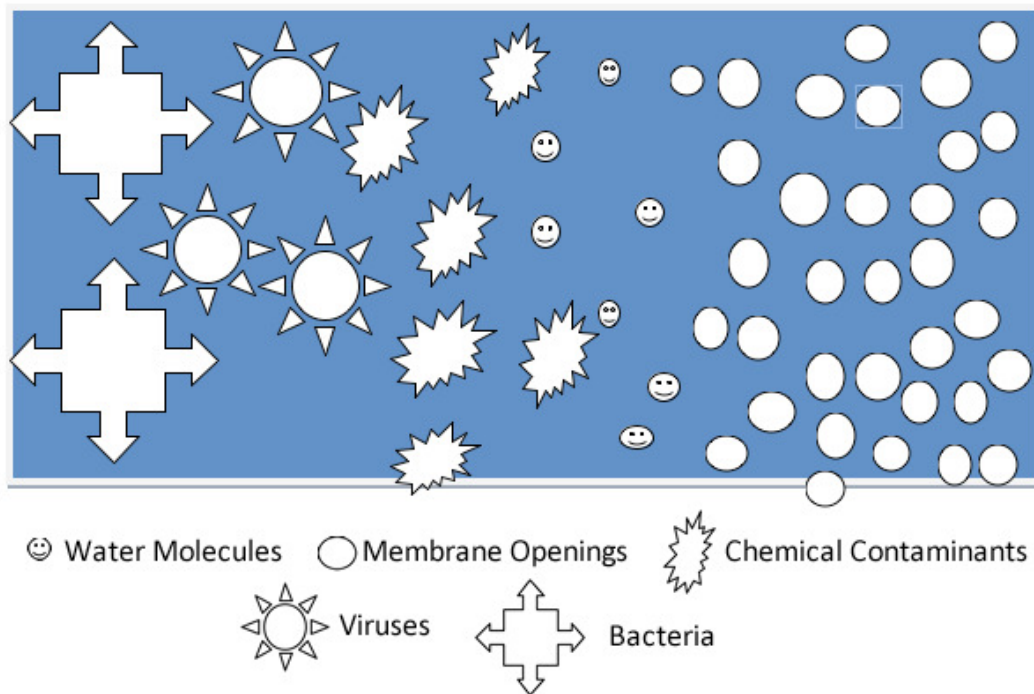

Even though the above illustration leaves something to be desired, The plain circles and ovals represent the openings in the semi-permeable membrane. Water molecules, the smiley faces, represent water molecules and would freely pass through the openings in the membrane. The jagged ovals represent chemical contaminants that could not fit through the openings. The stars represent viruses and they too are too large to fit through the openings. The arrowed rectangles represent bacteria and they are much too large to fit through the openings in the membrane.

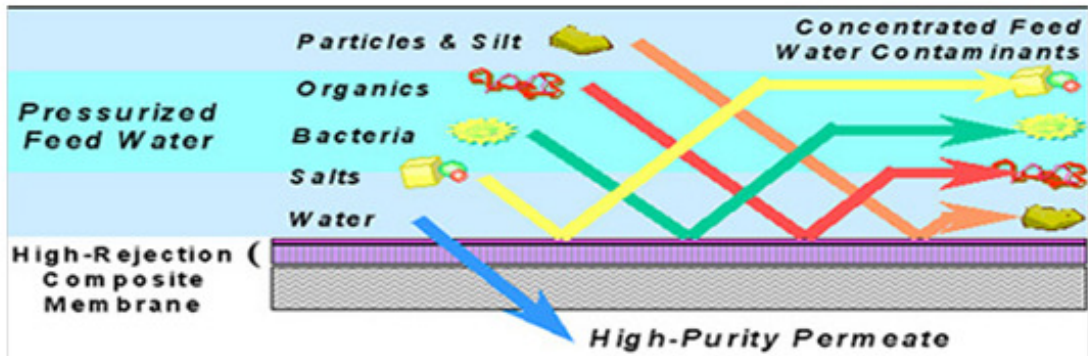

Vacuum driven membranes are becoming more widely used for potable water treatment. Most of these vacuum driven membranes pull the water through 2700 or so thin membrane “strands” per bundle that separate the water from the contaminants. These bundles are arranged in racks and submerged in the raw water. Every 10 seconds or so, the water in the membrane tanks are aerated to scrub the membranes. Every 15 minutes the vacuum pressure is reversed to back pulse clean water through the membranes pores to purge dirt from the membrane surface. These types of membranes come in single header (attached at the bottom only) and double header (attached both top and bottom) and then lowered into the raw water tank. In both single and double header configurations, the air flow is reversed to backwash the filter. The membranes are pictured below.



There are a number of membrane plants in operation here in Kentucky. Logan-Todd, Jamestown, Madisonville among others are already on-line and Ohio County, Campton, and Paintsville’s new membrane plants are currently being constructed or planned.

***Review Questions for Chapter 7 – Alternative Treatment Processes***

1. A circular unit that combines coagulation, flocculation and sedimentation in a single unit are called \_\_\_\_\_ .
2. The process where microsand is added to increase floc size, density, and weight is referred to as the trade name \_\_\_\_\_ .
3. Are upflow clarifiers or solids contact units stable or erratic under changing temperatures and flow rates? Explain how upflow clarifiers and solids contact units remain stable or erratic under changing temperatures and flow rates.
4. The operator of a solids contact unit controls the performance of the treatment process by controlling chemical dosages, the recirculation of the slurry and \_\_\_\_\_. Describe the roles of an operator in relation to a solids contact unit.
5. DAF is an acronym that stands for what? Identify what DAF means.
6. Which type of non-conventional treatment process actually uses two filters?
7. The membrane filter with the smallest pore sizes is called what? Identify the pore sizes of each membrane filter.
8. The process by which membranes accomplish their task is actually \_\_\_\_\_. Describe the process of how membranes accomplish their task.
9. Membrane filtration systems require minimal or a great amount of pretreatment? Identify the level of pretreatment needed by a membrane filtration system.
10. Name the two types of membrane filtration most frequently used in municipal drinking water applications.

***Answers to Review Questions for Chapter 7 – Alternative Treatment Processes***

1. upflow clarifier units
2. Actiflo
3. changing flow rates, turbidity levels, temperatures
4. Sludge control
5. Dissolved Air Flotation
6. Roberts Filter Group
7. Reverse Osmosis
8. size exclusion
9. require substantial pretreatment
10. microfiltration and ultrafiltration

# Chapter 8: FILTRATION

## Chapter 8 Objectives

1. Explain how pressure filters differ from conventional sand filtration.
2. Determine how the filtration process works and explain sieving, adsorption and straining.
3. Are there different types of filters and if so, how are they different?
4. Determine how uniformity coefficients, effective size, specific gravity, and hardness impact filter media
5. Determine which should be at the top of the filter – the smallest media or the largest media and where most of the particulate is hopefully stored.
6. Decide whether the statement; “Filtration’s job is to remove pathogens and particulates.” is a valid one.
7. List the different ways flow control is accomplished in the filtration process and how they differ
8. Determine at what amount of feet of head the filtration process reaches saturation.
9. Describe what factors could interfere with filtration.
10. Explain why slow sand filtration isn’t viable for medium to high volume facilities.
11. Define a schmutzdecke.
12. Decide whether or not the dissolved oxygen content of the treated water could have a profound impact on filtration rates, maximum filtration rates for all types of filters
13. Calculate flow in ft<sup>3</sup>/sec and gpm, velocity, and filtration/backwash rate and backwash expansion rates.
14. Define backwash, turbidity spikes, “ideal” filter runs, and how to determine the efficacy of the operator’s individual filter runs.
15. Explain what regulations determine to be necessary notations for filter operation and how long such notations need to be retained.
16. Determine turbidity goals for the optimization of the filtration process.
17. Decipher what significance backwash expansion rates have on viable filtration.
18. Define a “filter profile” and determine what valuable information can be garnered from such an endeavor.
19. Explain what a floc retention analysis or core samples can illuminate.
20. Determine the alternatives to replacing filter media.

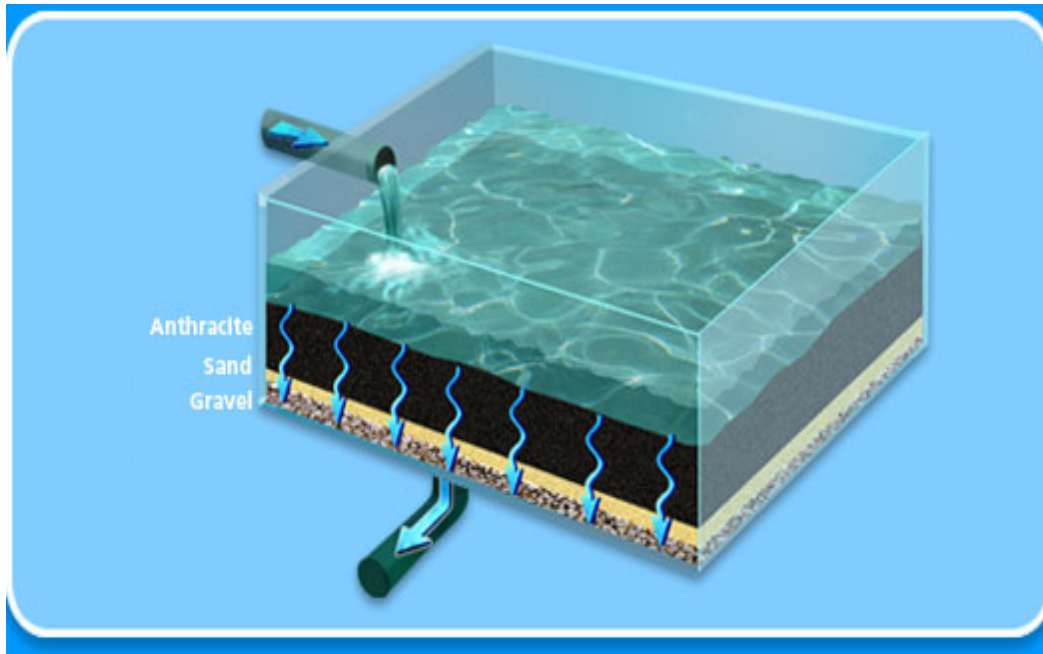

### ***Filtration Process Description***

The purpose of filtration is to complete the removal of particulate impurities from the water being treated. It is the final barrier or treatment process for particle removal and is accomplished by passing water through a bed of granular material such as sand, anthracite, garnet, activated carbon, etc. or by forcing or drawing water through a membrane.

The particulate impurities removed should include:

- **Particulate fraction** – debris and microbes that easily removed
- **Colloidal fraction** – very fine clays and microbes that will pass through a 0.45 micron filter but are NOT in true solution.
- **Dissolved fraction** – natural organic matter (NOM), reduced organics, among other entities that are in true solution and will pass through filters

**EFFECTIVE PRETREATMENT IS IMPERATIVE FOR THE SUCCESSFUL REMOVAL OF COLLOIDAL AND DISSOLVED FRACTIONS**



### ***Filtration Performance Goals***

- Turbidity :  $\leq 0.10$  NTU 95% of the time
- Maximum turbidity  $\leq 0.30$  NTU
- Post backwash turbidity
- With filter – to – waste return to service  $\leq 0.10$  NTU
- Without filter – to – waste  $\leq 0.30$  NTU and return to  $\leq 0.10$  within 15 minutes

### ***Types of Filters***

- Gravity Filters – the primary type of filters used by surface water treatment plants
  - Slow Sand
  - Rapid Sand
  - Mixed Media

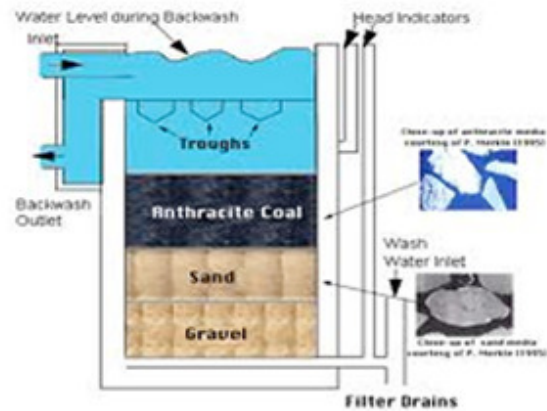
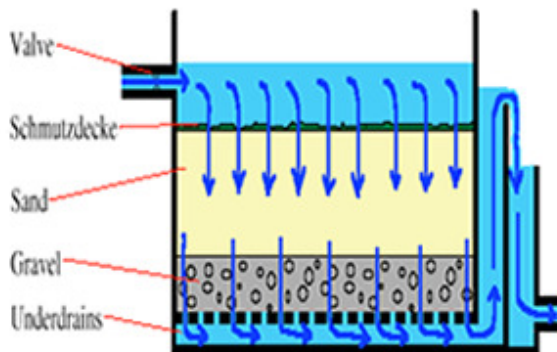

*Water passes through charcoal, sand, and gravel layers in a water system's filtration tank.*

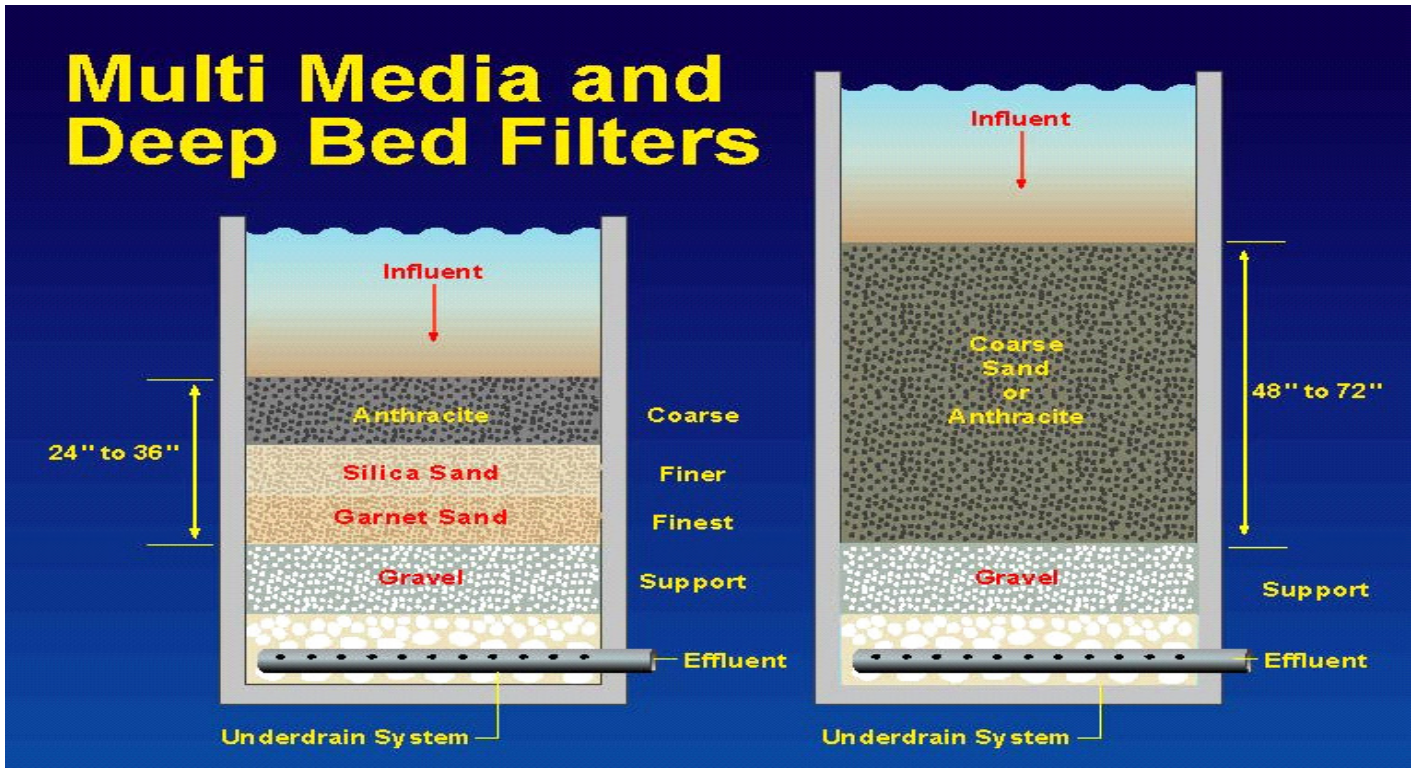

*Comparison of Slow-Sand, Rapid-Sand, and High-Rate or Mixed Media Filters*

CHARACTERISTIC	SLOW – SAND FILTERS	RAPID - SAND FILTERS	HIGH - RATE FILTERS
Filtration Rate	0.05 gpm/ft <sup>2</sup>	2 gpm/ft <sup>2</sup>	3 – 8 gpm/ft <sup>2</sup> *
Media Distribution	Unstratified	Stratified – fine to coarse	Stratified – fine to coarse
Filter Runs	20 – 60 days	12 – 36 hours	12 – 36 hours
Loss of Head	0.2 feet initially to 4 feet final	1 foot initially to 8 or 9 feet final	1 foot initially to 8 or 9 feet final
Amount of Backwash Water Used	Backwash Not Used	2 – 4% of filtered water	6% of filtered water *5 gpm/ft <sup>2</sup> in Ky

**Slow Sand**

- Cannot be backwashed
- The majority of the particulates are removed in the top few inches of sand
- The sand layer has to be physically removed when the filter becomes clogged
- Low filtration rates (as low as 0.1 gpm/ft<sup>2</sup>) dictate large filter area be used for larger quantities of water.

**Dual Media**

- Filtration rate of 2gpm/ft<sup>2</sup> of filter
- Majority of the particulate stored in top layers of filter

**Mixed Media**

- Filtration rate of 3 -5 gpm/ft<sup>2</sup> of filter
- Usually made up of sand, anthracite and garnet
- Majority of the particulate stored in top layer of filter.
- Pressure Filters – used primarily for groundwater or higher quality water sources
- Granular Media – greensand, sand, anthracite, etc.
- Membrane – micro, ultra, nano, and reverse osmosis.

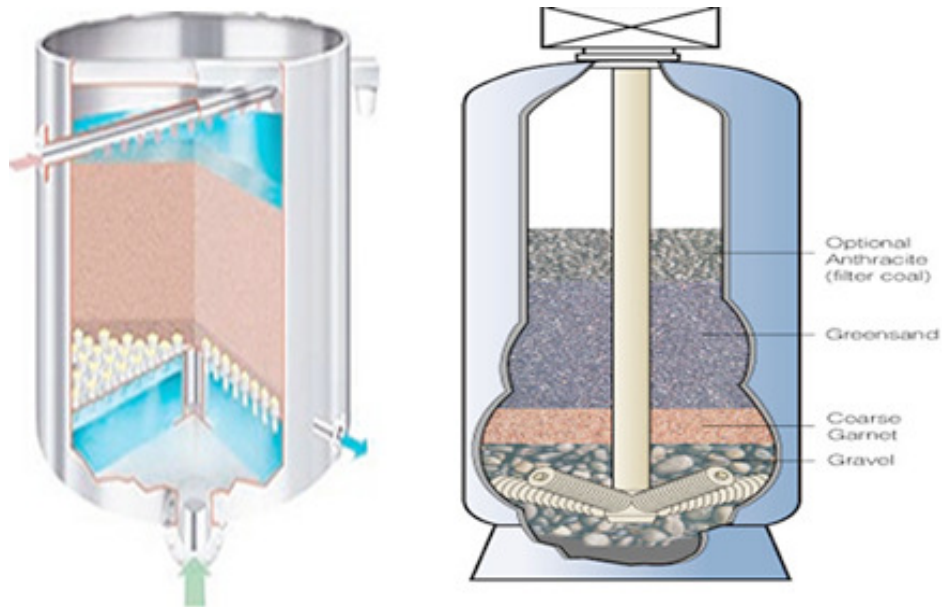

**Particulate removal by filtration is dependent upon:**

- Source water quality
- Physical and chemical characteristics of the suspended particulates
- The effectiveness of your pretreatment (coagulation, flocculation, and sedimentation)
- The type, condition and operational control of the filter being used.

### ***Removal Mechanisms of Filters***

- sedimentation on filter media
- adsorption
- biological action
- absorption
- straining

**Adsorption** is the binding of molecules or particles to a surface and must be distinguished from **absorption** which is the filling of pores in a solid. The binding of these particles to the surface is usually weak and is reversible. Otherwise our efforts in backwashing a filter would be for naught. Just about everything, including our water that dissolves or suspends the material is bound, but compounds of taste and odor and color tend to bind strongly.

### **Adsorption versus Absorption**

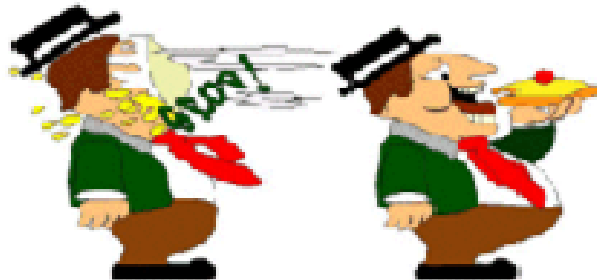

### ***Particle Removal***

We, as operators, must understand that filters do NOT remove particles, they only temporarily store them during the filtration process until backwash occurs. The key to successfully operating a filter is to keep these particles in storage until backwash can properly dislodge and remove them; or, before other forces allow particles to penetrate the filter. Particles are temporarily stored in a filter bed primarily by these two means:

§ **Straining**

- The large particles are too large to fit through the porous volume between the filter media grains.

§ **Adsorption, Sticking, or Attachment**

- The smaller particles come into contact with, and stick to, previously stored particles or the surface of the filter media grains.

It needs to be noted that dissolved particles that are in true solution will pass through a filter and therefore must be brought out of solution (precipitated) by the use of some pretreatment process.

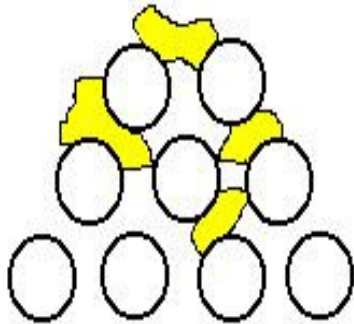

**Mechanical Straining**

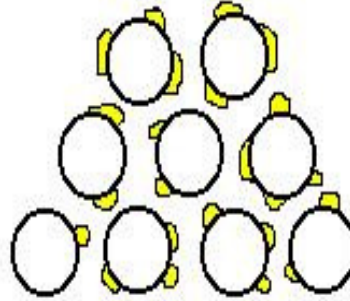

**Physical Adsorption**

This distinction between particle storage and removal is an important one because the smaller particles are stored in the filter bed by sticking to the surface of our filter media and can, under certain conditions, detach from the filter media resulting in turbidity breakthrough in the filter effluent. Also, the smaller particles will not be captured and stored in the filter until the filter has been “seasoned”. “Seasoning” is where the media grains have settled back into place after backwashing and where larger floc has settled on the media to provide a greater surface for small particles to stick or attach to. One issue is that the smallest of these particles will not be detected by a turbidimeter.

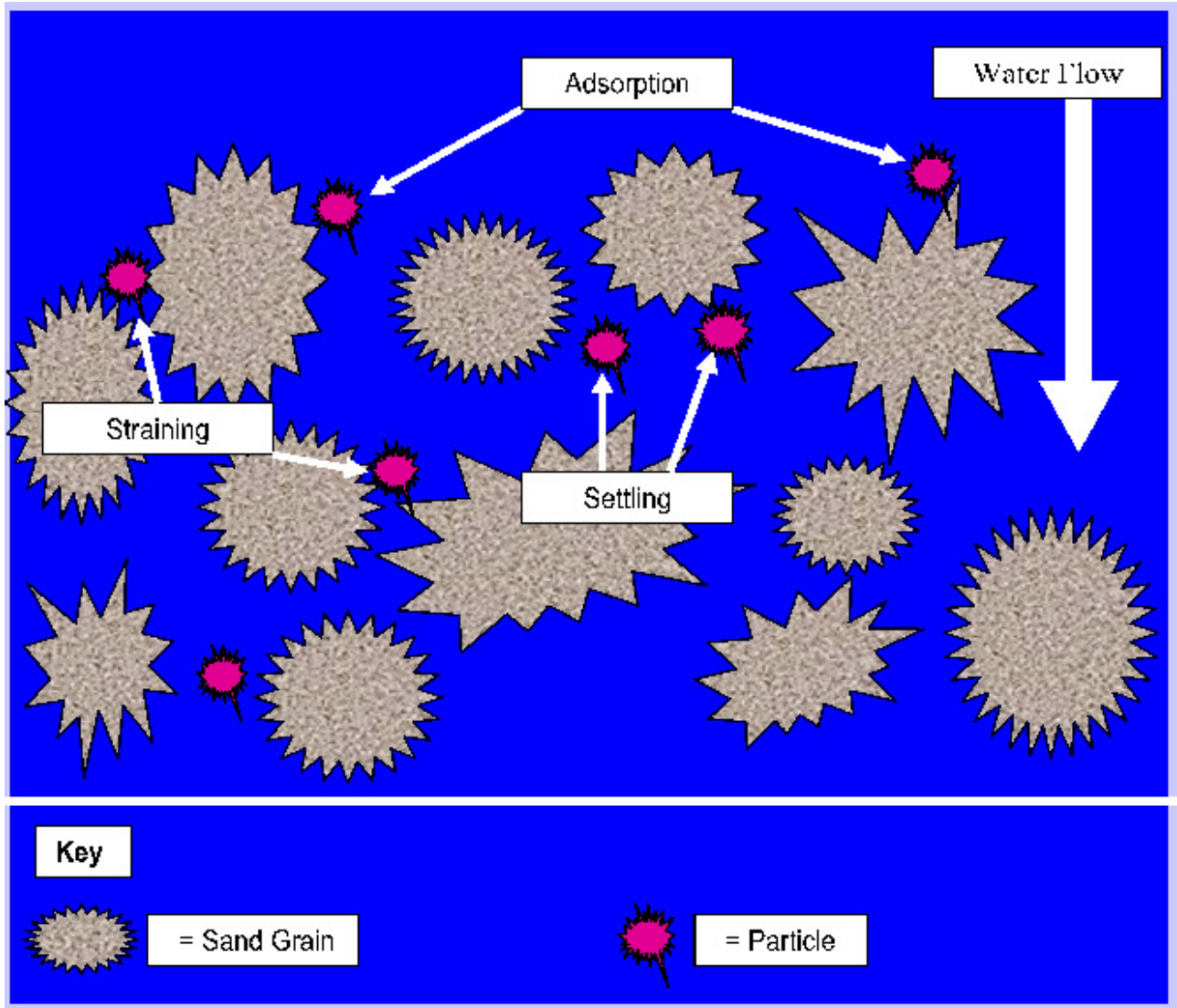

***Desirable Filter Media Characteristics***

- § Good hydraulic characteristics (permeable)
- § Inert, does not react with substances present in the water
- § Hard and durable
- § Free of Impurities
- § Insoluble in water

Filter media are classified according to their effective size, uniformity coefficient, hardness, and specific gravity.

**Effective Size** – Two factors are important when selecting filter media

1. The time required for turbidity to breakthrough the filter bed.
  2. The time required for the filter to reach limiting or terminal headloss
- § If the media is properly selected these two times are about the same.
- § If limiting headloss is a problem and turbidity breakthrough rarely occurs, then a larger filter should be considered.
- § If turbidity breakthrough is frequently an issue and limiting headloss is rarely encountered, then a smaller media size should be considered.
- § If both breakthrough and limiting headloss both frequently occur, a deeper filter bed and larger media size should be considered.

**Uniformity Coefficient**

Obviously a value that describes how uniform or alike in size each media grain is; the *lower the value, the more uniform* then the more uniform the grains are that comprise the filter media.

Generally, the more uniform the media grains the slower the rate of headloss and turbidity breakthrough at a particular flow rate.

**Hardness**

Hardness is determined of various minerals to be scratched by another harder object and categorized by a scale called the Mohs hardness number. A minimum of Mohs hardness of 2.5 – 3 is frequently specified for anthracite coal. The hardness of filter grains is important as it pertains to the durability of the media over extended periods of time.



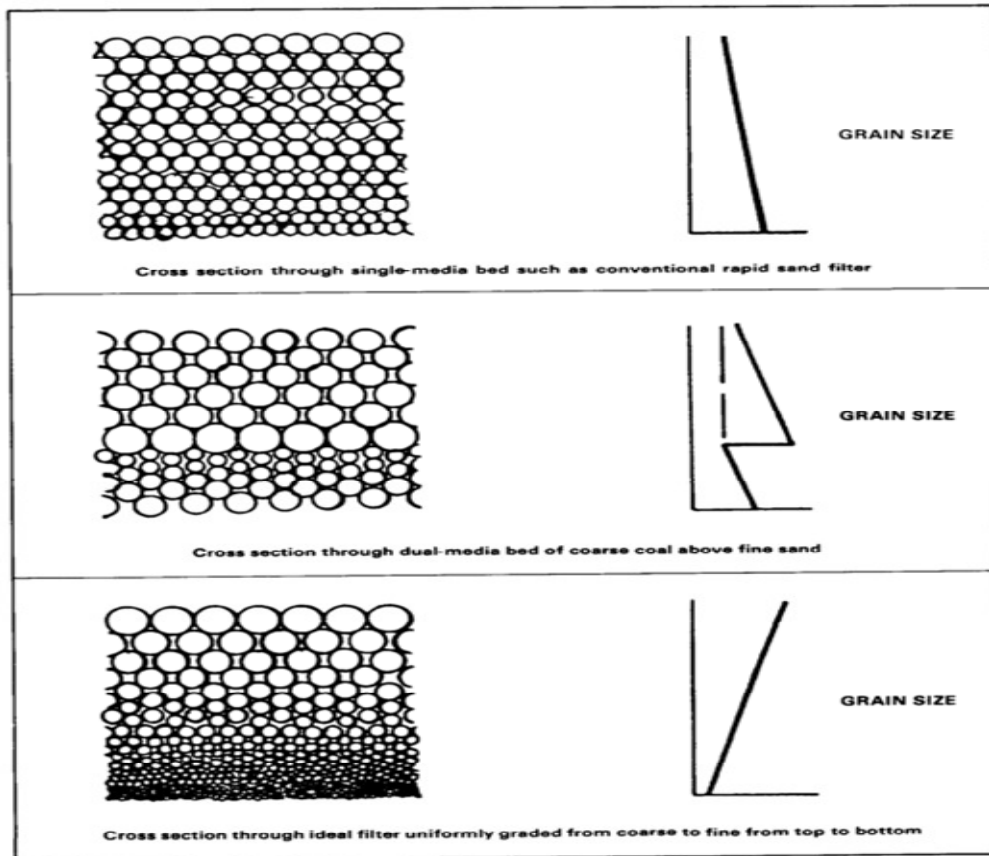

Figure 1-3. Filter bed cross section

### Specific gravity

In this instance, specific gravity describes the weight per unit volume of a particular media type. Media with the greatest specific gravity will occur at the greatest depths of the filter. This occurs because specific gravity is also the weight of a substance in relationship to an equal volume of water. Filter grain size should, however, decrease with increasing filter depth.

### Flow Control in Gravity Filters

During the filtering process, water is applied to the filter in order to maintain a constant depth or 4 – 5 feet over the filter media. At the beginning of the run the filter is clean and headloss is very low. The filtration rate, or velocity, is kept at the desired rate by the use of a control. A control is also important in preventing harmful surges (abrupt velocity changes), which can disturb the media and release stored particulate from the filters.



### Rate of Flow Controller

The rate of flow controller is used to maintain a constant desired filtration rate. In order to control the flow at the beginning of a filter run, the flow controller valve is almost completely closed. This produces the necessary headloss and maintains the desired flow rate. As the filtration run continues and the suspended material builds up in the filter, headloss increases. To compensate for this increase in headloss, the controller valve gradually opens. When the valve fully opens the filter run must end since further headloss can't be compensated for and the filtration rate drops precipitously. The major issue with rate of flow controllers (ROF) is its need for regular maintenance. If the valve is malfunctioning, issues including damage to the filter bed and water quality degradation could take place impacting the filtration rate of the filter.

### Variable Declining Rate Controller

The filtration rate isn't kept constant with this type of controller. The filtration rate starts high and gradually (hopefully) decreases as the filter gets dirty and headloss increases. Each filter is supposed to accept the proportion of total flow that its particular filter bed can handle. If this type of valve is in use, as a filter gets dirty, the flow through it decreases. So, the flow is redistributed to cleaner filters and the plant capacity doesn't decline. To prevent excessive flow rates from occurring in clean filters, a flow restriction device is placed on the effluent line of each filter.

### Split Flow

The influent is split by a weir allowing equal distribution of water to each filter. The filter effluent valve is controlled by the water level in each filter.

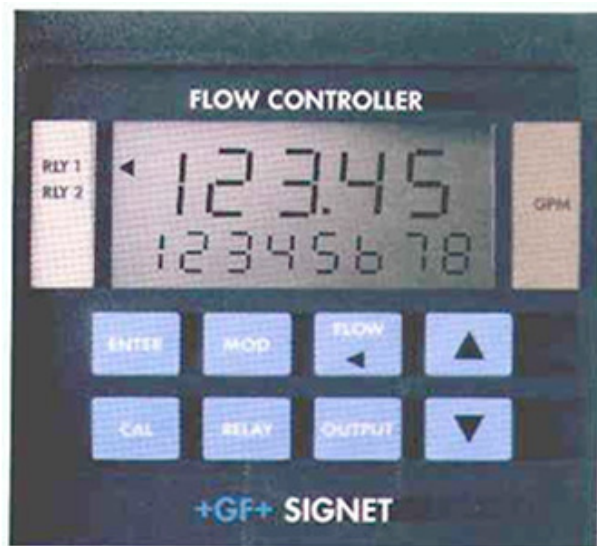
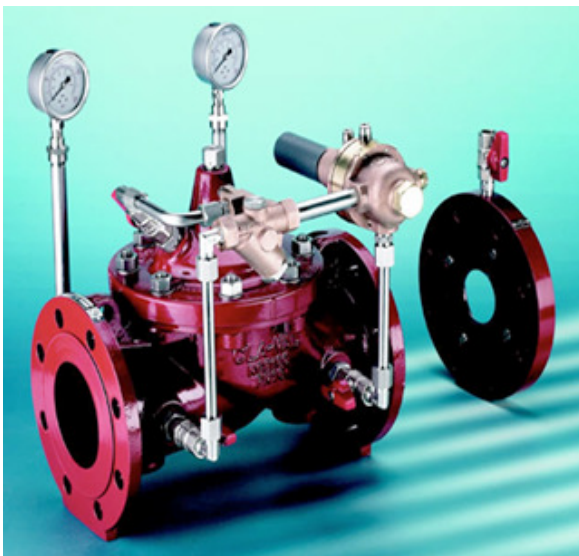

## Self Backwash

The water level in each filter varies according to the headloss, but the flow remains constant for each filter. Filter runs are preset and automatically controlled. These require the least operator skill but a lot of assumptions that each filter's condition is the same at the time of each preset backwash.

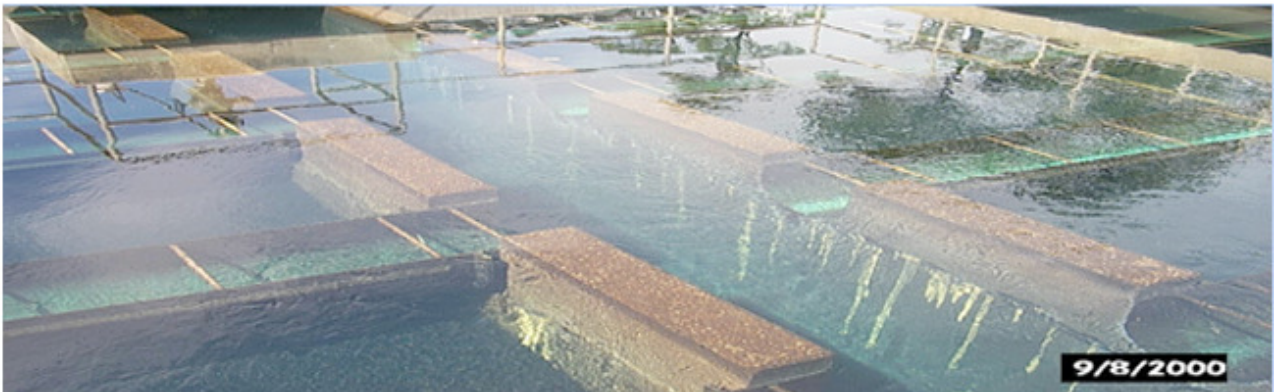

## Underdrains

Underdrain issues are frequently overlooked and sometimes suffer from the “out of sight, out of mind” syndrome because of the difficulty encountered in trying to see them.

Consider all of the duties that these devices are supposed to repeatedly successfully accomplish.

- § Uniform flow distribution through the filters
- § Uniform air flow distribution for air scouring
- § Uniform flow distribution for backwashing
- § Minimize media migration
- § Support filter media

There are a number of different underdrain systems and I am in no way endorsing any of them but rather attempting to display some different types.

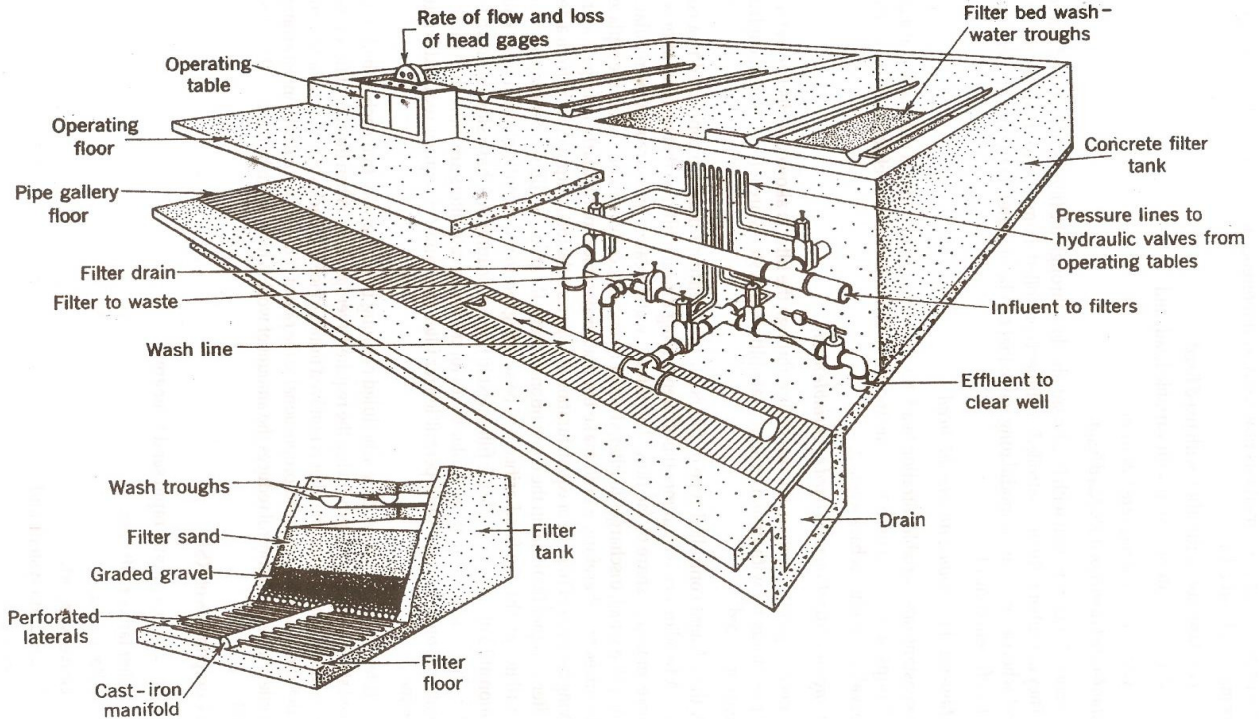

### Wheeler Underdrains



TYPICAL WHEELER UNDERDRAIN INSTALLATION

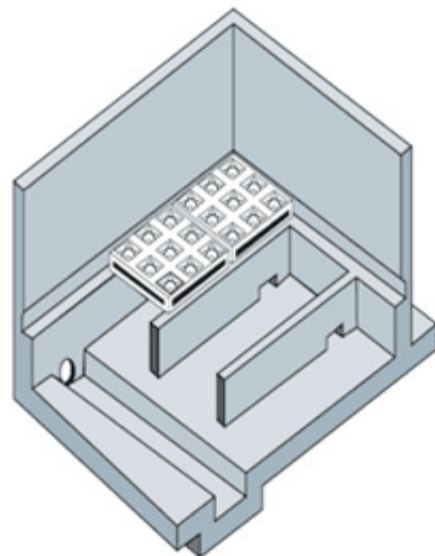

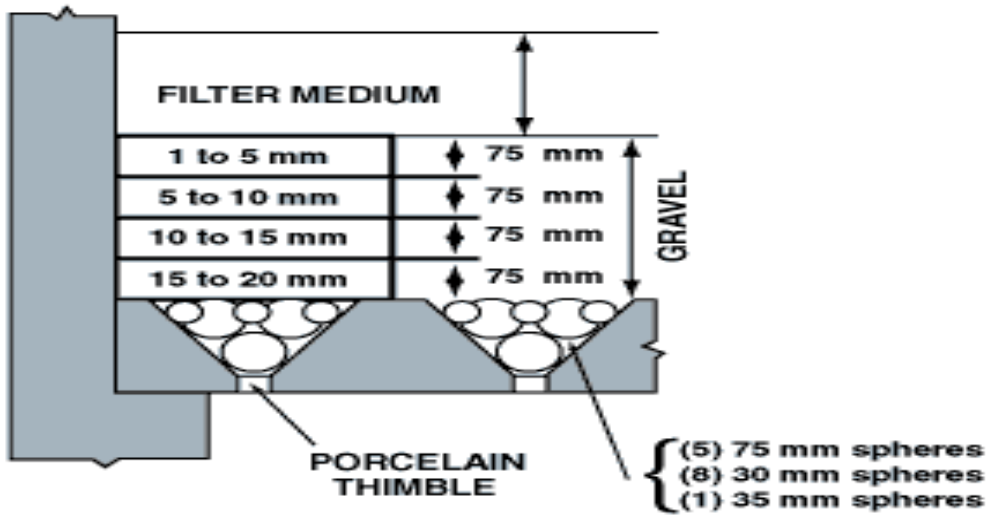

### Teepee Underdrains

TYPICAL TEEPEE UNDERDRAIN INSTALLATION

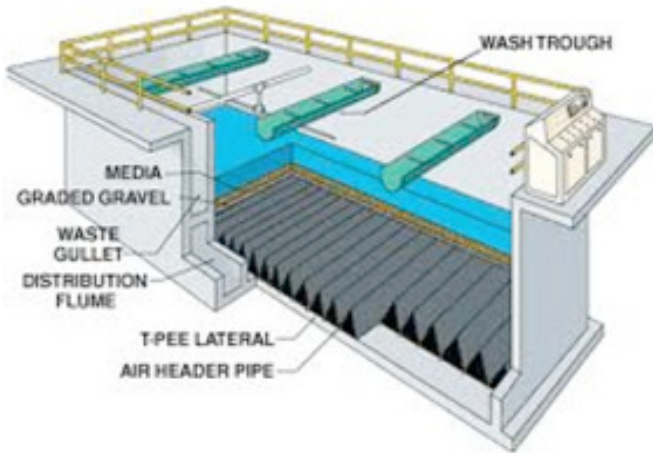

Tetra



### Perforated Tubing



Roberts Filter Group

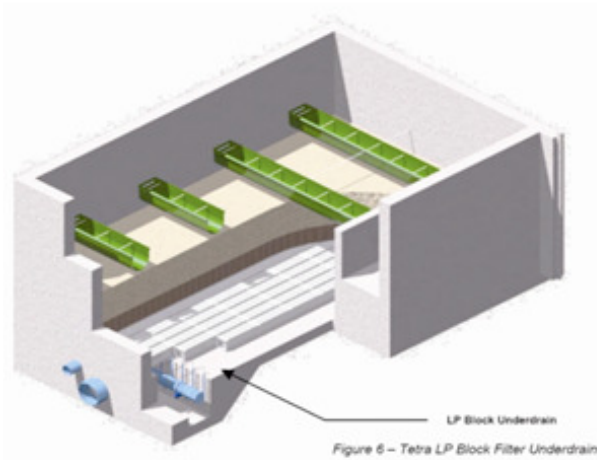
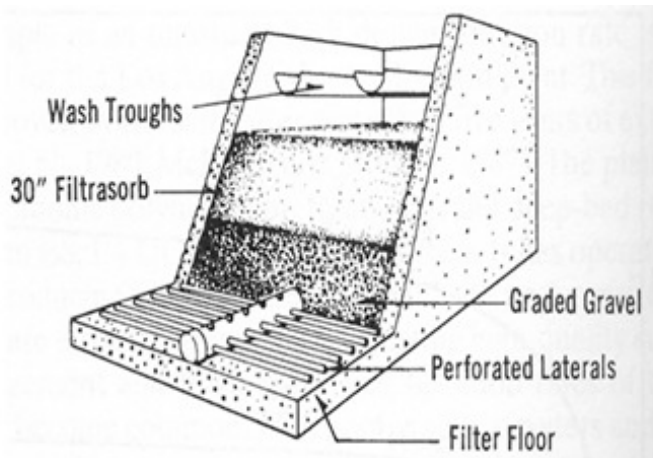

LP Block Underdrain  
Figure 6 - Tetra LP Block Filter Underdrain

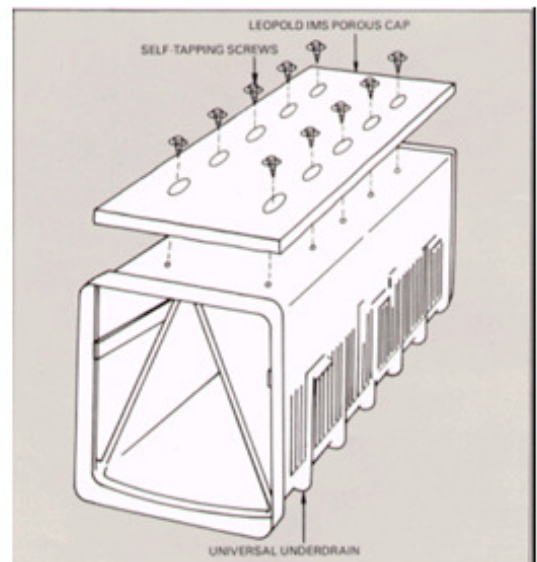
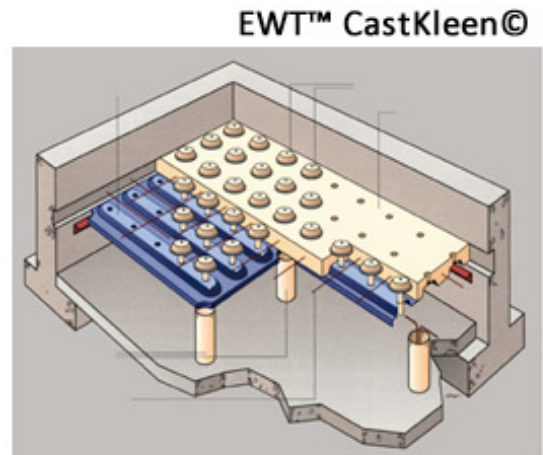

**Filter Media Inspection?**



What is needed is the uniformity of dispersion of water and air (if so equipped) throughout the filter.

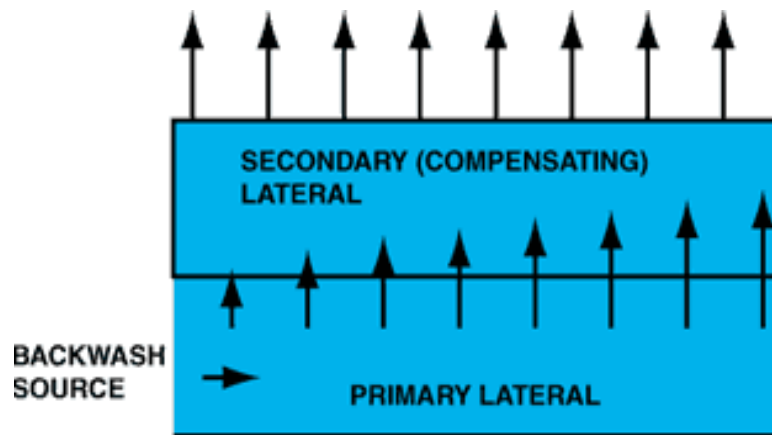

Some problems can arise which can adversely affect the success of your efforts in filtration and backwash.

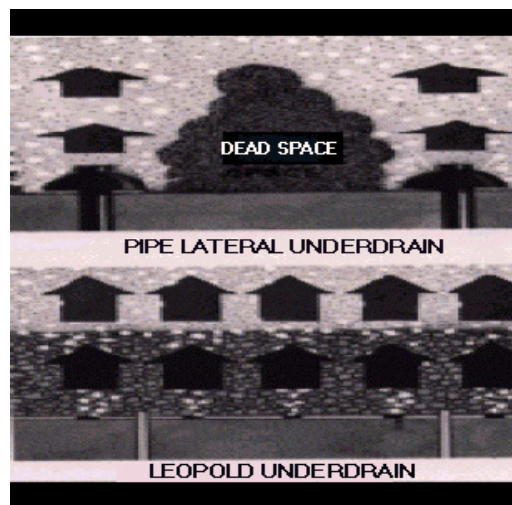

If the underdrain system is never scrutinized, media migration can occur with uneven media depths and flow rates that will affect filtration and backwashing.

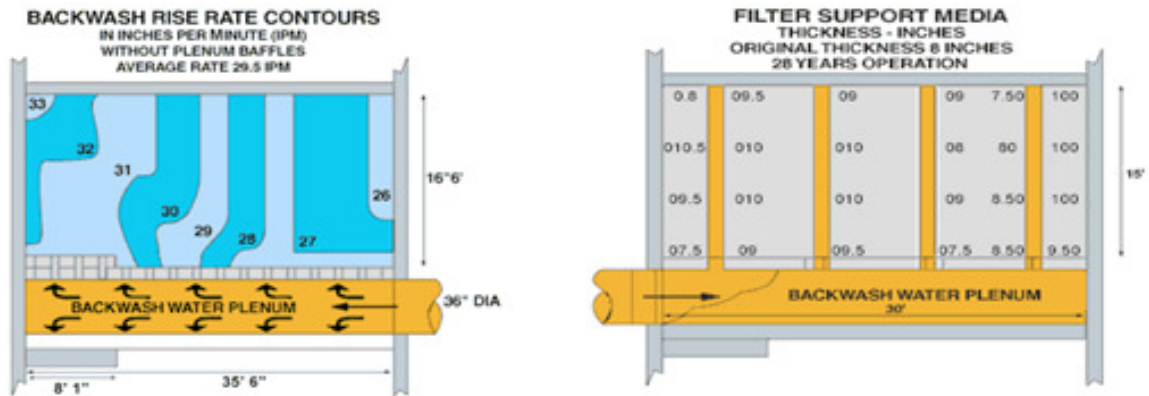

### ***Interfering Substances***

Dependent upon circumstances such as time of year, temperature, and a myriad of others, substances can enter our plants that interfere with the normal process operation. Frequently the process that is most impacted is filtration.

#### **Algae**

- § Many species of algae produce objectionable tastes and odors.
- § A profuse growth of algae interferes with the chemical treatment of raw water by changing the pH and hardness levels.
- § Some algae act as inhibitors to coagulation.
- § Algae can clog filters.

#### **Dissolved oxygen**

- § DO can cause a significant resistance to flow through the filter.
- § Dissolved oxygen can permeate the filters and fill up the available space which can lead to air binding of the filters.

#### **Other Interferences**

- § Surface clogging and cracking caused by an overload of solids at the thin sand interface in rapid sand filters.



Gravel displacement or mounding that can usually be halted by the addition placing a 76 mm layer of coarse garnet between gravel supporting the media and the fine bed media.

Mudballs caused by the agglomeration of particulates in the filter which can be reduced by air scouring, surface wash, or, in some instances, increasing the backwash rate.





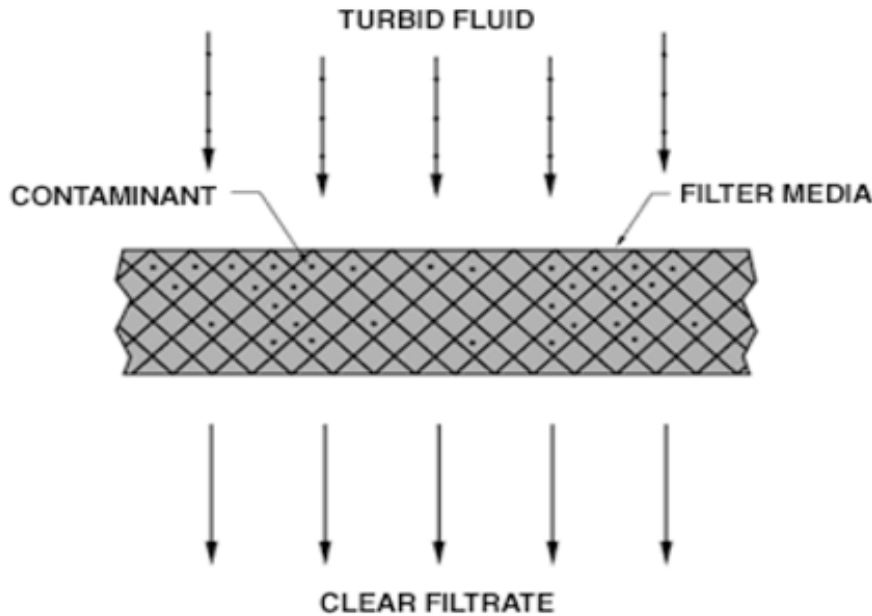

Filtration rates are determined by dividing the total **flow** (gpm) by the total filter area (ft<sup>2</sup>). This calculation can be used to determine the **velocity** or speed of the water moving through the filter bed at any given point in time. Changes in velocity should be slow and gradual.

### FLOW and VELOCITY

**Q = Flow expressed in cubic feet per second  
(ft<sup>3</sup>/sec) (cfs)**

**This denotes a volume over time. Other ways we  
denote volumes over time are:**

**gpm  
MGD**

**V = Velocity is expressed in feet per second (fps).**

**This denotes distance over time.**

**State troopers usually express this to me in tickets  
denoting so many miles per hour!**

As particles are stored in a filter bed, “A” (AREA) becomes smaller in value.

As “A” becomes smaller, “V” (VELOCITY) becomes larger.

And, if “V” becomes too large..... STOP THE FILTER RUN.

**Examples:**

Spriggs Treatment Plant treats water at a rate of 1.8 ft<sup>3</sup>/sec through 80 ft<sup>2</sup> of filters. What is the velocity of the water through the filters?

Greenbo treats water at a rate of 1400 gpm through four filters, each measuring 6 feet square. What is the velocity of the water passing through the filters?

$$V = Q \div A \quad V = 1.8 \text{ ft}^3/\text{sec} \div 80 \text{ ft}^2 \quad V = 0.0225 \text{ fps}$$

$$V = Q \div A \quad V = (1400 \text{ gpm} \div 448.8 \text{ gpm}) \div (6 \text{ ft} \times 6 \text{ ft} \times 4 \text{ filters})$$

$$V = 3.12 \text{ ft}^3/\text{sec} \div 144 \text{ ft}^2$$

$$V = 0.021 \text{ fps}$$

***Filtration and Backwash Rates***

$$\text{FILTRATION RATE} = \text{Flow (gpm)} \div \text{Surface Area (ft}^2\text{)}$$

$$\text{BACKWASH RATE} = \text{Flow (gpm)} \div \text{Surface Area (ft}^2\text{)}$$

You will notice that there is a distinct similarity between filtration and backwash rates. If you can do one, you can do the other.

**Example:**

Your plant treats 1200 gpm and has 800 ft<sup>2</sup> of filter surface area. What is the filtration rate?

$$\text{Filtration Rate} = \text{Flow (gpm)} \div \text{Surface Area (ft}^2\text{)}$$

$$\text{Filtration Rate} = 1200 \text{ gpm} \div 800 \text{ ft}^2$$

$$\text{Filtration Rate} = 1.5 \text{ gpm/ft}^2 \text{ filter}$$

An alternative formula for determining filtration rates is as follows:

FILTRATION RATE = every 1.6 inches/minute of rise or fall is equivalent to 1 gpm/ft<sup>2</sup>

**Example:**

After observing the filters you have measured a 6.4 inch fall in the last minute. What is the filtration rate?

$$\text{Filtration Rate} = \text{every 1.6 inches/min} = 1 \text{ gpm/ft}^2$$

$$\text{Filtration Rate} = 6.4 \text{ inches} \div 1.6 \text{ inches}$$

$$\text{Filtration Rate} = 4 \text{ gpm/ft}^2$$

**Practice:**

Pineburg treats 6.2 MGD through eight filters measuring 10 feet wide by 15 feet long by 10 feet deep. What is the filtration rate?

$$\text{Filtration Rate} = \text{Flow (gpm)} \div \text{Surface Area (ft}^2\text{)}$$

$$\text{Filtration Rate} = (6.2 \text{ MGD} \times 694.5 \text{ gpm}) \div (10 \text{ ft} \times 15 \text{ ft} \times 8 \text{ filters})$$

$$\text{Filtration Rate} = 4306 (4305.9) \text{ gpm} \div 1200 \text{ ft}^2$$

$$\text{Filtration Rate} = 3.6 \text{ gpm/ft}^2 \text{ (actually } 3.5883333 \text{ rounded up)}$$

### ***Headloss Development***

Media grains are not compressible but the solids that are temporarily stored by the filter are compressible.

As velocity increases, solids become more compressed leading to greater headloss development.

As filter runs increase, solids become more compacted which leads to greater backwash (flow rate/duration) requirements.

**Filter Aids** (polymers) can be added to the filter bed to improve particulate storage mechanisms but may also increase headloss characteristics.

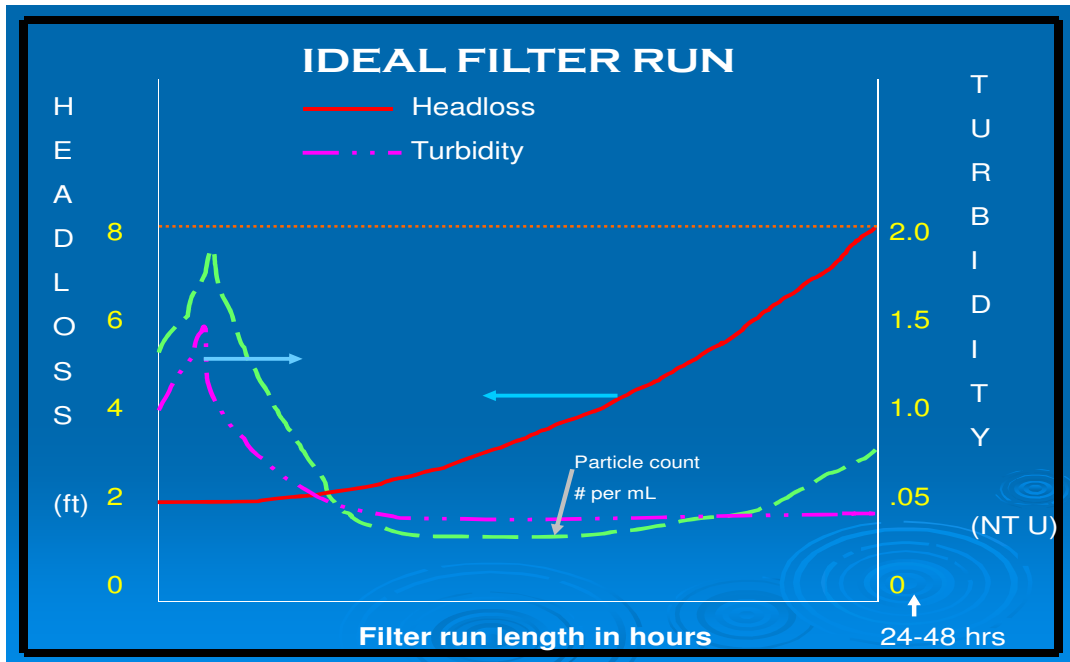
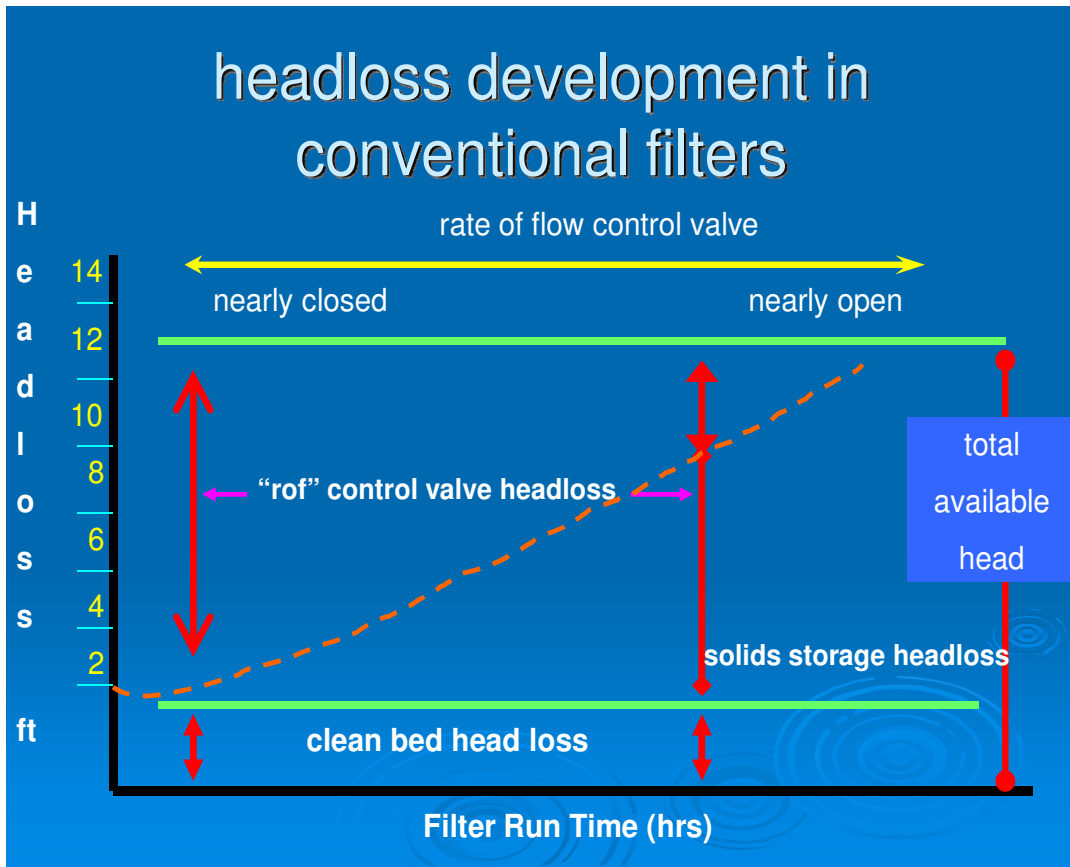

Filter runs **should be terminated** whenever:

- Effluent turbidity (or particle count) exceeds pre-determined standards
- Headloss exceeds a pre-determined level (usually 6 – 10 feet of head)
- A pre-determined filtrate volume is reached

Keep track of unit filter run volumes (UFRVs) and production efficiencies

**Terminate filter runs @**

- 10,000 gal/ft<sup>2</sup> for conventional filtration
- 5,000 gal/ft<sup>2</sup> for direct filtration

$$\% \text{ Production Efficiency} = \frac{\text{UFRV} - \text{UBWV}}{\text{UFRV}}$$

\*Where UBWV = unit backwash volume, gal/ft<sup>2</sup>

**THE GOAL SHOULD BE TO MAXIMIZE PRODUCTION EFFICIENCY  
WHILE CONTINUALLY MEETING SELF – IMPOSED WATER QUALITY STANDARDS THAT  
EXCEED REGULATORY IMPOSED LEVELS.**

## ***Backwash***

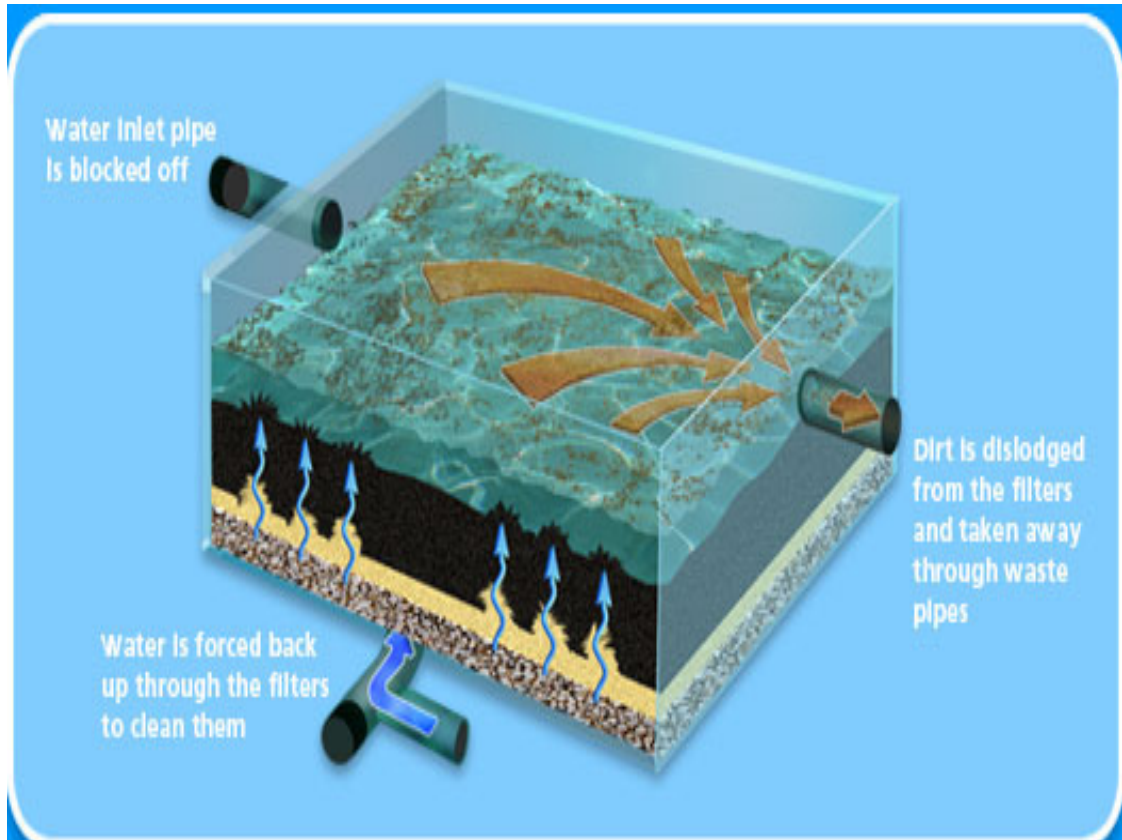

**BACKWASING IS AN IMPORTANT STEP IN THE ENTIRE TREATMENT PROCESS AND IS THE CRITICAL STEP IN THE FILTERING PROCESS. INADEQUATE BACKWASHING CAUSES MOST OPERATING PROBLEMS ASSOCIATED WITH FILTRATION.**

Once a filter run has been terminated (due to pre-determined standards), it is taken out of service for cleaning. Backwashing is the process of reversing the flow of water through the filter media in order to remove the stored particles that have been deposited in the filter.

In addition to outlining the basis for initiating a backwash, a protocol involving this procedure should provide step – by – step instructions on how to properly backwash the filters and all operators should follow them exactly. These instructions should delineate the backwash sequence including when to use the surface sweep or air scour system and the length of time they should be run.

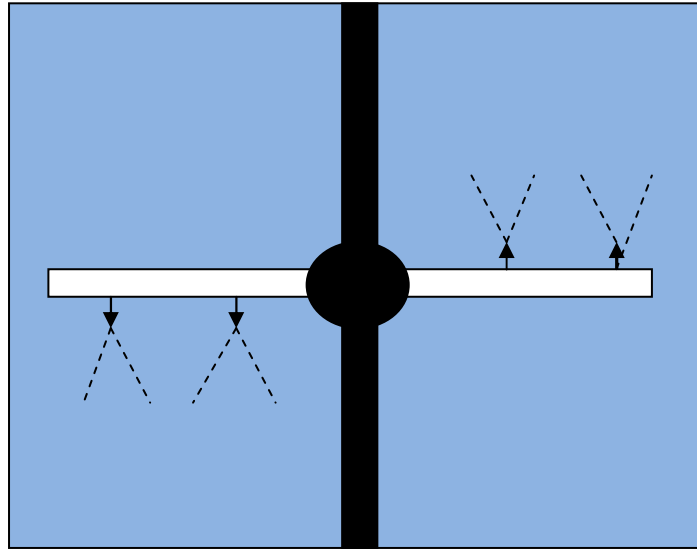

The instructions should indicate the backwash sequence including when to use the surface wash or air scour system and for how long they should be run. The operator may need to turn off the surface wash during maximum backwash rates to prevent the loss of filter media. Backwash length, backwash rate, and the length of rewash should also be included in the protocol. As in most instances, experience is the best teacher so optimum backwash parameters are developed over time through experience and analysis.

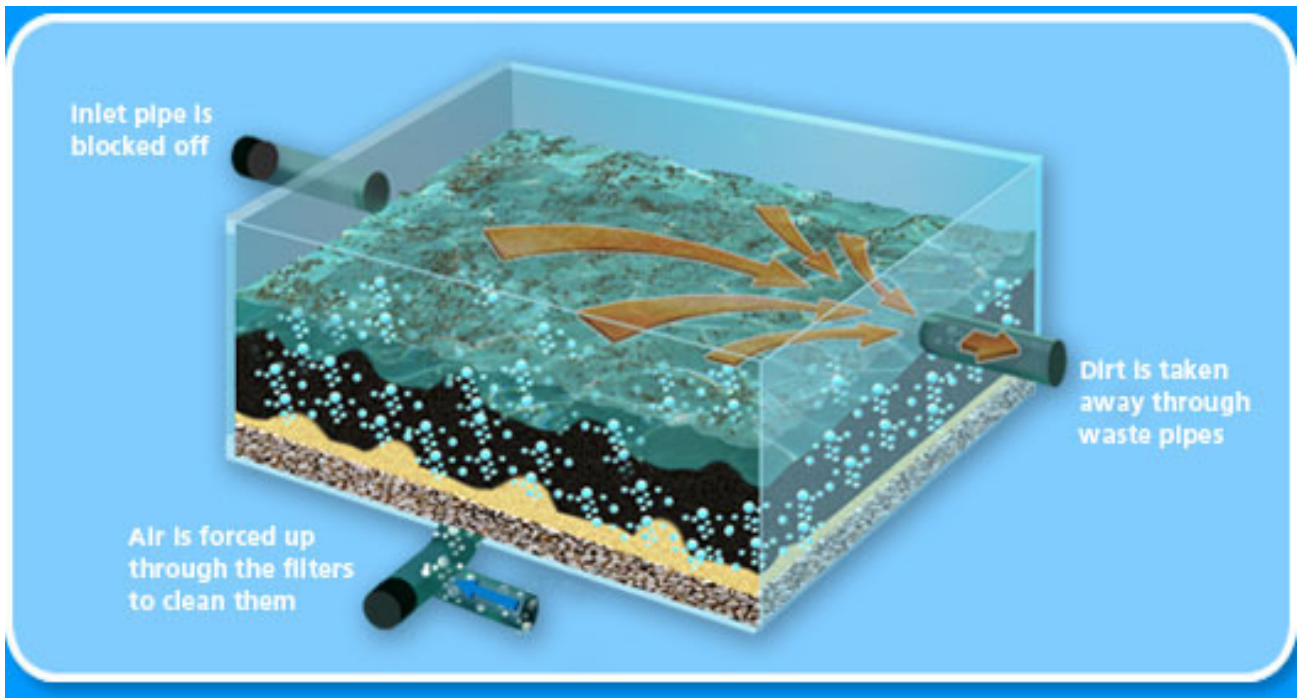

In surface washing, strong jets of high pressure water from fixed or revolving nozzles assist in breaking the filter surface crust. Design parameters for surface wash could include:

- Provisions for water pressure of at least 45 psi,
- A properly installed reduced pressure zone assembly backflow prevention assembly to prevent backsiphonage if connected to the treated water system,
- A rate of 2.0 gpm/ft<sup>2</sup> of filter with fixed nozzles or 0.5 gpm/ft<sup>2</sup> with revolving arms.

As with filtration, backwash rates (velocity) should be allowed to change in a slow and gradual manner only. Rapid or abrupt changes in velocity will disturb the filter bed and ultimately result infiltration problems.

Bed expansion should be in the 20 – 35% range dependent upon particular filter design and viable operating parameters although new KyDOW new facility design specifications stipulate a 50% expansion rate. Every filter should achieve the same bed expansion whenever it is backwashed. Backwash rates should be changed dependent upon changing conditions, such as temperature, in a manner that will achieve the same bed expansion with each wash cycle.

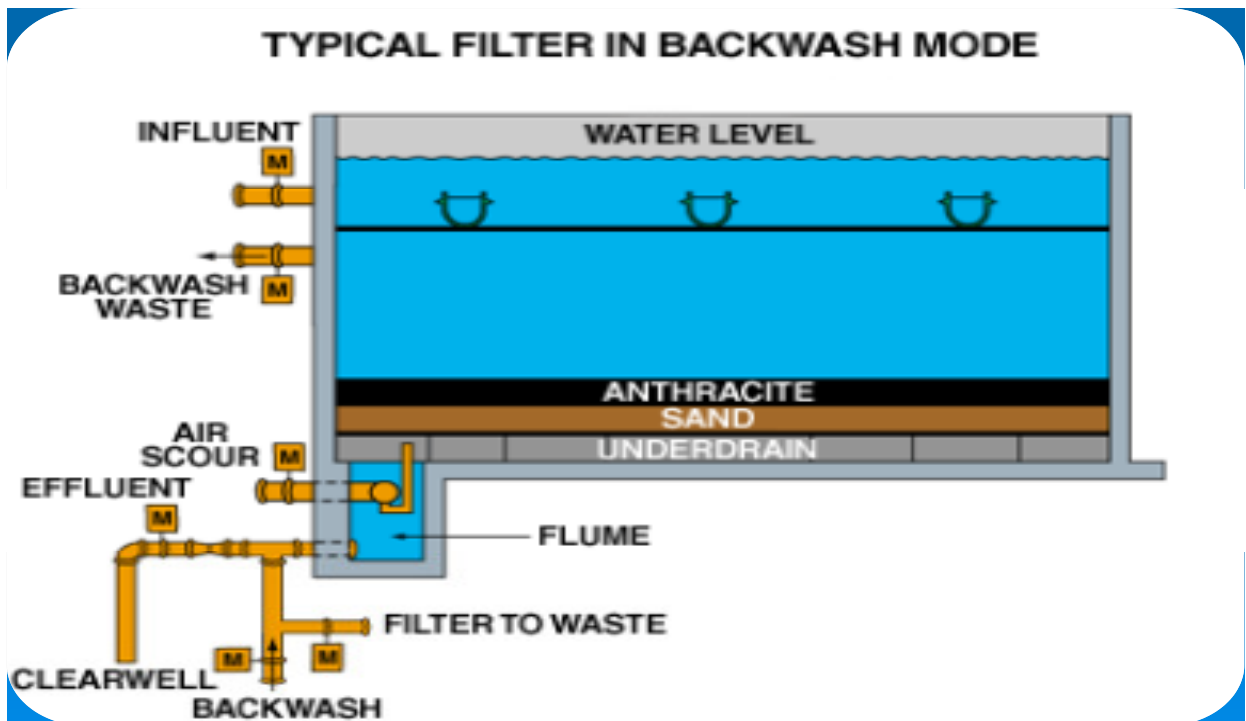



### Backwash Scouring Action

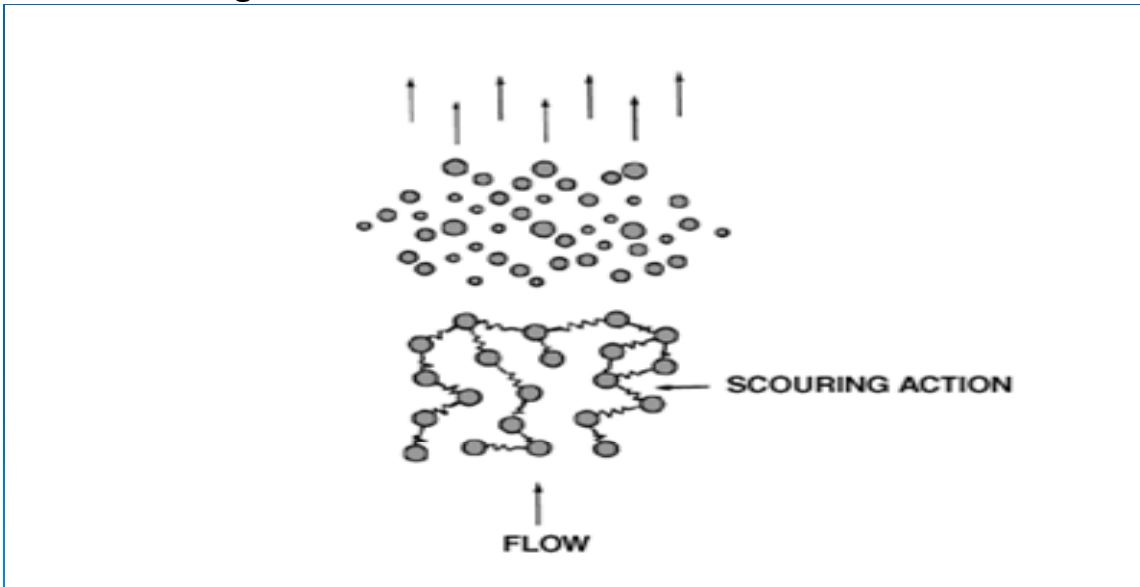

### Determining Backwash Filter Bed Expansion

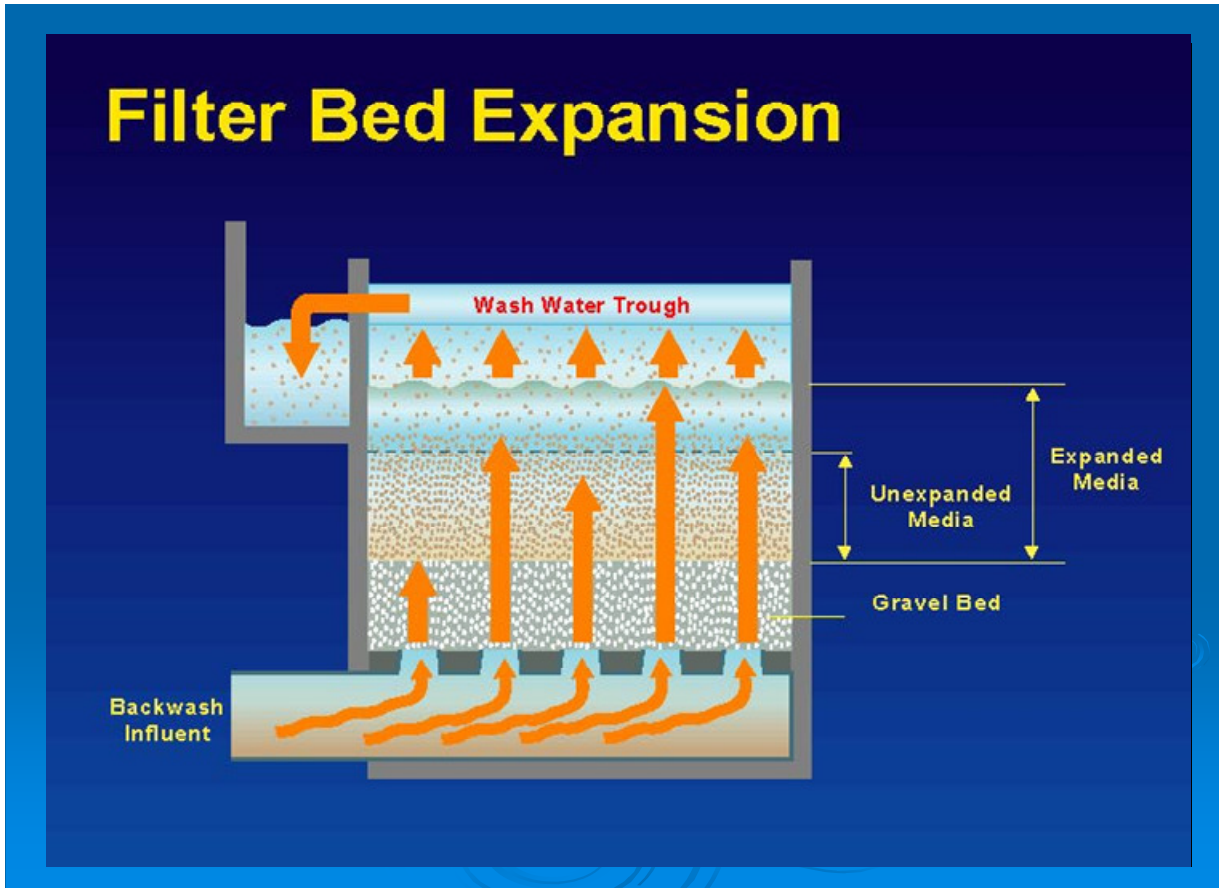

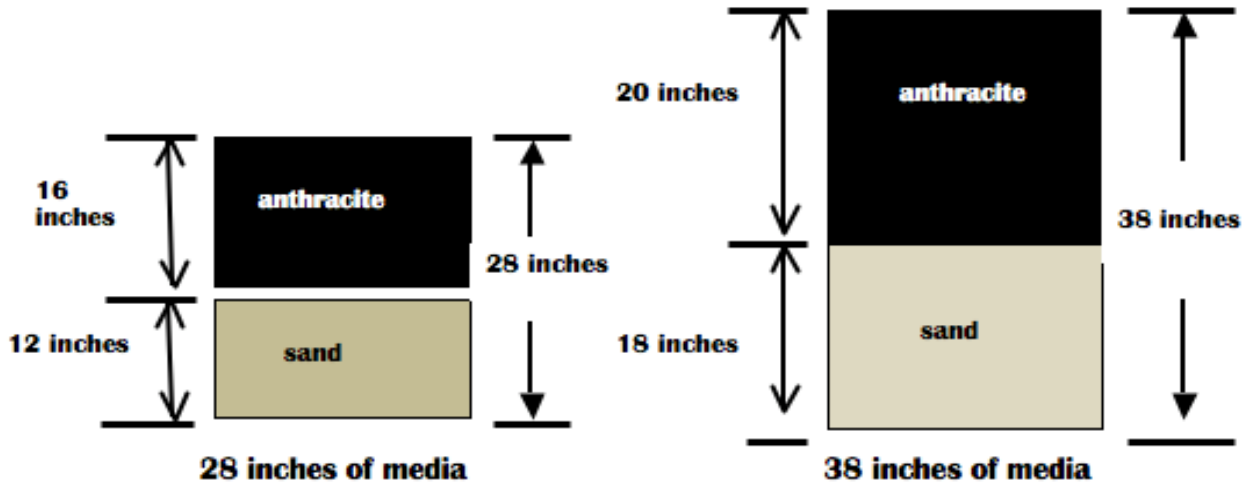
*Determining filter bed expansion*

$$\{ (38 \text{ inches} - 28 \text{ inches}) \div 28 \text{ inches} \} \times 100 = 35\% \text{ Expansion}$$

**What is an ideal expansion rate?**

**Too little:** inadequate fluidization of the media will not dislodge and remove enough of the stored particulate that will aid in the development of mudballs. Mudballs impede flow which will cause uneven velocities through the filter which can eventually result in boils, vortexing, cracks, media de-stratification and clogging of the underdrain.

**Too much:** over fluidization will limit the collisions that will help clean the filter media. This will lead to longer backwash cycles and consequently, more of your production water used to sufficiently wash the filter. Additionally, filter media will be lost, resulting in shallower filter bed depths and less particle storage capacity in the affected filter during future filter runs. As a result, filter runs will be shortened and production efficiencies will suffer.

**How long should the backwash run be?**

**Too short:** if the filters are still dirty after backwash, they will need to be washed again before normal UFRVs are achieved. This will also detrimentally affect production efficiency.

**Too long:** the filter media could become too clean resulting in excessive ripening periods (turbidity spikes) associated with the rewash cycle. Again, production efficiency is lost due to the longer filter – to – waste periods required.

For treatment facilities with filter – to- waste (rewash) capabilities, the rewash should be long enough to allow the initial turbidity spike to pass. Ideally, backwash should continue until the effluent turbidity is  $\leq 0.1$  NTU. If the filter is in good condition and the settled water quality is good, this should occur within a few minutes. If it doesn't, re-evaluate the pretreatment processes as well.

## Impact of Backwash Recovery Spikes on Filter Performance (cont.)

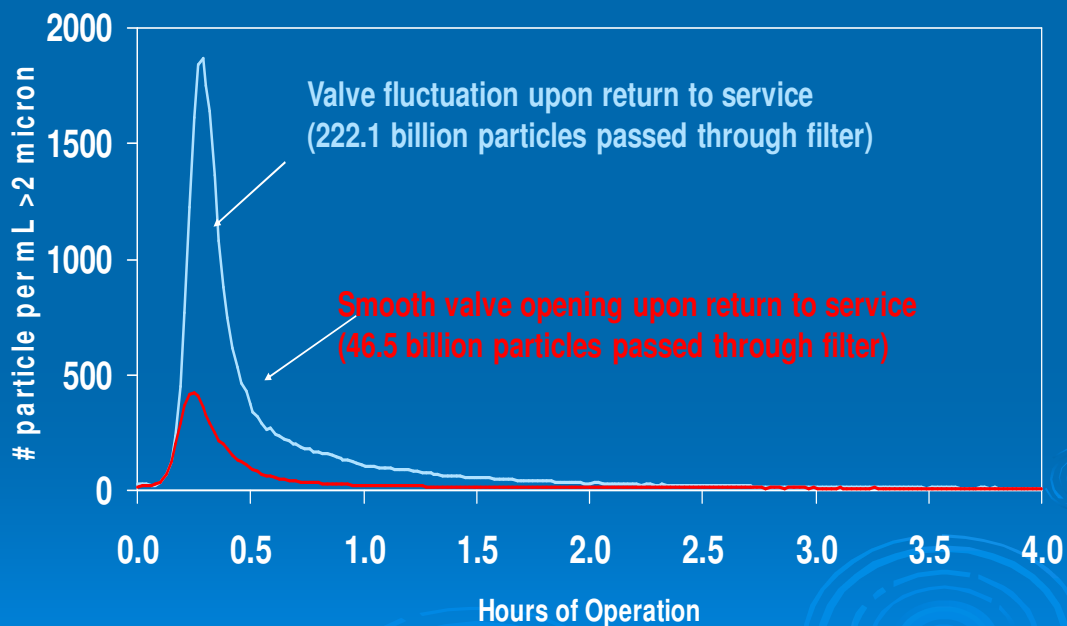

Source: Region of Ottawa-Carleton Water Division

<b>“TYPICAL” BACKWASH SEQUENCE</b>			
<b>Air &amp; Water</b>		<b><u>Water Only</u></b>	
<b>Air Only</b> <b>4 scfm/ft<sup>2</sup></b>	<b>2 minutes</b>	.....	.....
<b>Air/Water</b> <b>4 scfm/5 gpm</b>	<b>3 minutes</b>	<b>Low Wash</b> <b>7 gpm/ft<sup>2</sup></b>	<b>2 minutes</b>
<b>Water Ramp to High Wash</b> <b>5 gpm/ft<sup>2</sup></b>	<b>1 minute</b>	<b>High Wash</b> <b>17 gpm/ft<sup>2</sup></b>	<b>15 minutes</b>
<b>High Wash</b> <b>17 gpm/ft<sup>2</sup></b>	<b>5 minutes</b>	<b>Low Wash</b> <b>7gpm/ft<sup>2</sup></b>	<b>3 minutes</b>
<b>105 gallon/ft</b>	<b>&lt; WATER USAGE &gt;</b>		<b>290 gallon/ft<sup>2</sup></b>

*Determining Filter Bed Expansion with a SECCHI DISC*



## A “TYPICAL” BACKWASH CYCLE

- Lower the level of settled water below troughs
- Observe the filter bed for cracks, mounds or holes
- Begin the surface wash (and/or air scour) to break up the surface crust
- Start the backwash SLOWLY to begin loosening collected material and to gently remove any air that may be bound in the filter. Observe the filter media for any localized violent bubbling action.
- GRADUALLY move into high-rate backwash to expand media and expel trapped sediments. End the surface wash (and/or air scour) at this time to minimize media migration or loss. Measure the filter bed expansion.
- When the turbidity of the wash water reaches the pre-determined level, GRADUALLY reduce the backwash rate to allow the different media grades to properly re-stratify.
- Observe the filter bed for vortexing, mounding, or media migration.
- Rewash (filter – to – waste) until the turbidity spike has been observed and filtrate meets pre – determined standards (0.1 NTU).
- The rewash cycle (turbidity spike) will be significantly minimized and filter performance maximized if the filter can be kept “off – line” or, out of use or service, until the next filter wash when it will be recycled back into operation.
- SLOWLY and GRADUALLY move back into the filtration mode until the maximum filtration rate is reached.



***Techniques Used to Control Turbidity Spikes AFTER BACKWASH***

Filter – to – waste until preset standards for turbidity and/or particle counts are met: The goal is to obtain satisfactory filtered water quality rather than terminating the filter – to – waste process according to a set time period. The length of time for filter – to – waste is site specific and varies with source water quality and the success of pretreatment efforts. Generally, filter – to – waste until the initial turbidity spike falls to 0.1 NTU.

**Requirements:** Filter – to –waste piping must be adequate enough to handle the design flow thus assuring a smooth transition (minimizing changes in water velocities through the filter bed) between the effluent and filter – to – waste valves when switching from one to the other. Turbidimeters or particle counters must be capable of measuring rewash so that water quality can be continuously monitored during the filter – to – waste cycle.

**Delayed start:** Take the backwashed filter out of service until another needs washing. This allows additional time for filter media to settle tightly into place and for the floc to settle onto the media, increasing attachment mechanisms. Generally a longer delay means a shorter spike. This method may also prevent velocity changes (spikes) in all other filters during a given filter wash.

**Requirements:** The total plant capacity must be able to be met with one filter out of service. Too long of a rest for the filter may require another backwash or chlorination of the filter. Check Cl<sub>2</sub> residuals.

**A slow, gradual start:** Start the filter at a slow rate and gradually increase flow over a period of time (20 – 30 minutes) using multiple rate increases while limiting the magnitude of each change.

**Requirements:** You must have rate of flow control valves that are capable of supporting gradual increases in multiple steps.

**Chemical conditioning of the media:** Coagulant or polymer is added to either the backwash water or the initial influent water to improve attachment actions. This helps condition the filter media and destabilize the charges on particles left in the filter following backwash.

**Requirements:** Trial and error is the only real way to determine the type of chemical to be used, the proper dosage, and the duration of the dosage. Alternate

filter runs with chemical addition or dosing and with no chemical addition to verify the effect of each change. Start with a low dosage and gradually increase it until positive monitoring results are obtained. Consult references before implementing this type of treatment.

When added to backwash: Dosage is critical and must be monitored. Timing is important because coagulated water will remain in the underdrain and effluent piping and will subsequently be added to the clearwell. Because of this, dosages must end prior to ending the backwash cycle.

When added to the influent: A choice must be made between an initial slug dose at startup or a low continuous dose. Monitoring of the effluent is necessary for residual  $Al^+$  or  $Fe^+$  when metallic salts are used. Effluent pH monitoring is necessary if the settled water alkalinity is low. This procedure may not be effective at temperatures below 41° F because it slows the reaction time to a point beyond viability.

Ideal bed expansion can be determined by performing a floc retention analysis, filter coring, and backwash turbidity profiles on individual filters before and after a backwash. A comparison of different backwash rates for different durations of time will indicate the ideal expansion rate for effectively cleaning a filter. Subsequent filter washes would then hold constant the same bed expansion rate and wash duration with every wash while adjusting backwash flow rates relative to changing water temperatures throughout the year.

### ***Floc Retention Analysis or Filter Coring***

A floc retention analysis accomplished by coring the filter, can tell the operator exactly what is going on in the filter(s). If problems are discovered, a observation box inserted into the filter media to obtain a layer by layer view of the media can be very beneficial. The floc retention analysis can tell how much of the particulate your filter is storing, where in the filter is the particulate being stored and how uniform and effective your filter media is operating.

To perform the coring, pipes or conduit is pushed into the media at predetermined spacing and depths to see what the media interface looks like. This will also help to discover if mudballs are present in your filters. Before the actual coring the uniformity of trough height is measured as well as whether or not the troughs are level.

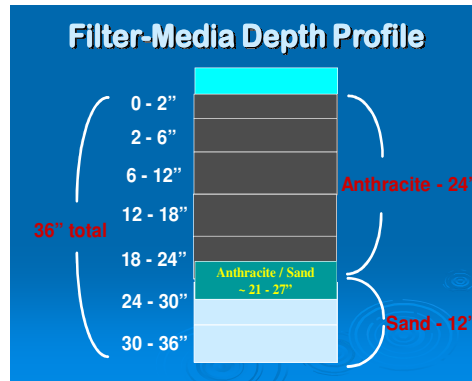

Some procedures require specialized instruments such as microscopes, or particle count analyzers but with simple tools, most of which are available at any hardware store, a wealth of information can be obtained about your filters.

**General equipment needed include:**

- S two 2 ft X 3 ft section of ¾ inch plywood
- S a 6 foot level
- S 25 foot tape measure
- S flashlight
- S 30 feet of heavy string or light cord
- S duct tape
- S stopwatch
- S permanent marker(s)
- S wire cutters

**Laboratory equipment necessary for sampling and monitors:**

- S one wide-mouth plastic liter bottle
- S large metal washers or 1 ½ inch cap (for weighted one-liter sample bottle)
- S 25 – 35 125 mL bottles for backwash turbidity samples
- S benchtop turbidimeter
- S 10-16 1,000 mL bottles for floc retention analyses
- S two 500 mL Erlenmeyer flasks with rubber stoppers
- S one 500 mL graduated cylinder
- S 1-gallon ziplock bags to collect filter media samples for effective size and uniformity coefficient
- S spoon
- S four 100 mL glass or plastic beakers
- S labels



**Additional tools**

Use a 6 foot  $\frac{1}{4}$  or  $\frac{1}{2}$  inch diameter metal or stainless rod with a flat bottom for a gravel probe. For the filter-coring device, use a 4-5 foot of 1  $\frac{1}{2}$  inch galvanized pipe or electrical conduit.

The bed-expansion tool can be constructed by gluing ten  $\frac{3}{4}$  inch PVC (schedule 80) pipes to a flat stock. These pipes should vary in length from 2 inches to 10 inches. The last pipe should be 24 inches long with a threaded coupling on the end so it can be attached to a 10 foot section of threaded galvanized pipe for stability during backwash. If more than 10 inches of rise is expected during backwash, additional pipes in 1 inch increments should be added to the flat stock to determine backwash filter bed expansion.

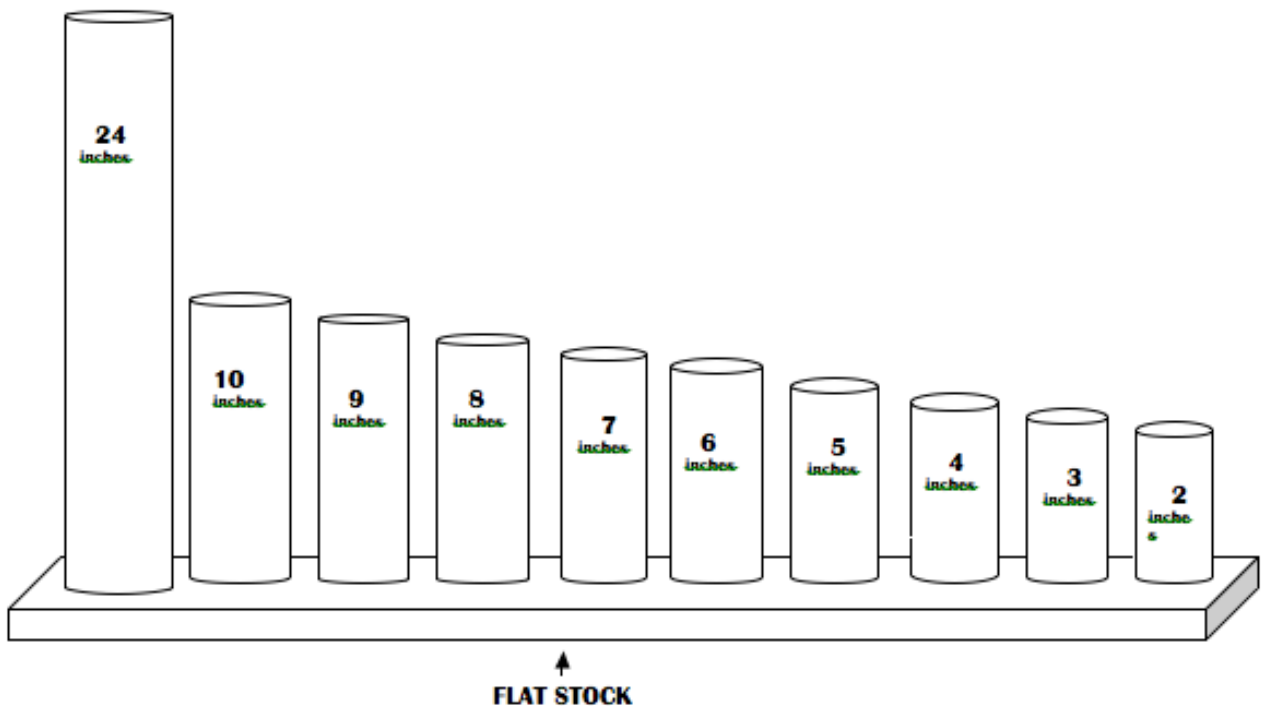

Also needed is a ten foot section of  $\frac{3}{4}$  inch galvanized pipe that will be used to stabilize the bed expansion tool, 24- 12 inch cable ties used to secure the bed expansion tool to the galvanized pipe, a rate-of-rise measuring tool (or yardstick attached to a 2 X 4) and a pan balance (optional). Sieves are needed to determine the effective size and the uniformity coefficient of the media although many plants farm out these tests. If you perform these tests at the plant, exercise care in separating different media sieve analysis to avoid devaluing the results.

Before starting the hands-on portion of the assessment an historical review of filter performance should be done. Review at least the past twelve months of plant operation

records and be sure to include filter run times, unit filter run volumes, loading rates, water quality data, pH, alkalinity, particle count data (if available), temperature, coagulant dosages, and include the filter's design and renovation records. When performing this assessment, plan on using 1.5 to 2 times the normal amount of backwash water because this inspection is not a regular backwash cycle. The entire process can take up to four hours and the filter will be out of service for as much as four hours with the laboratory analysis spanning four hours in duration.

Use the filter inspection sheets and a filter log to document the observations that are made during the inspection with special care being taken to accurately record all measurements and data being taken.



**Bagging the filter media for effective size, uniformity, coefficient, specific gravity and floc retention analysis.**

1. Document the filter's run time , UFRV, effluent turbidity, headloss, wash-water meter, surface wash meter(if applicable), the level of wash-water supply tank, and the level of the wash-water drain tank.
2. Completely drain the filter.
3. Look for cracks, holes, depressions, or mounds in the filter media.
4. Determine if the wash-water troughs are level and notate the result.
5. Determine if the media is level by measuring the freeboard and record the results.
6. Determine if the gravel is level and notate.
7. Notate the condition and the height above the media of the surface wash laterals (if equipped).
8. Inspect for debris and/or mudballs in the media.
9. Inspect the depth and condition of the media interface (where each differing layer of the media joins another).
10. Collect media samples for effective size, uniformity coefficient, specific gravity and floc retention analysis.
11. Install the bed-expansion tool.
12. Install the rate-of-rise tool.
13. Begin backwash.
14. Measure the rate of rise before the water reaches the bottom of the wash-water troughs and compare that reading with the backwash and surface wash flowmeters.
15. Observe flow patterns
16. Collect a backwash water sample every 30 seconds for turbidity analysis.
17. Time each process; surface wash, low wash, high wash, entire wash
18. At the end of the wash, notate wash water meters, wash-water supply tank levels, wash-water drain levels and use the data to determine the accuracy of the flowmeters.
19. Completely drain the filter
20. Repeat step 3
21. Remove the bed expansion tool and record the results.
22. Collect media samples for post floc retention analysis. Backwash the filter (a short wash to stratify the media and remove the foam).
23. Filter-to-waste, ramp, or let the filter stand for 2 – 4 hours (dependent upon conditions) and put the filter into service. Notate the procedure and the time elapsed for the filter effluent to reach your turbidity goal.
24. Perform turbidity analyses on samples collected in step 16.
25. Perform floc retention analyses on media samples collected in steps 10 and 22.

**Media and Wash-Water Trough Levels (Steps 4 and 5)**

Use a 4 or 6 foot level to determine if the wash-water troughs are level. Check both sides of each trough in three locations and across the trough. You want to determine if the troughs are level with each other by laying the level across two adjacent troughs. Next, lay the level across the trough and measure from the top of the media to the bottom of the level to determine the freeboard and ascertain if the media is level. Collect six freeboard measurements (three on each side).

**Gravel Layer (Step 6)**

Determine and document the freeboard of the benchmark location for the depth of the gravel. Insert the metal rod probe at this location to find the top of the gravel layer by listening for a change in the sound of the probe as it goes through the media. Mark the probe with a permanent marker at the top of the media. Measure the probe from this mark to the point at which the probe strikes the gravel to determine the depth of the media. Document this benchmark depth on the filter inspection report. Dig a hole to the gravel at the benchmark location to determine the accuracy of the probing technique. If the technique is off by more than an inch, repeat the process until the top of the gravel layer can be accurately detected with the probe. Measure the media depth at each location a freeboard measurement was taken – six per wash-water trough. After probing half the filter, measure and dig again to confirm the accuracy of the probe. Do not create a new benchmark. Adjust for variations in the freeboard to determine the total media depth and the variation in the top of the gravel layer. Graphing these variations is extremely helpful and will produce a visual picture of the gravel layer.

**Mudball, Media Interface, and Media Depth Inspections (Steps 7-9)**

Use the same holes dug for the gravel depth probe to determine the total media depth, whether mudballs are present, and the general condition of the media interface. It takes less time and creates a much smaller hole if the holes are dug by hand, instead of a shovel. Shake a handful of media gently through your fingers to identify any mudballs. Please realize that a wet clump of media is not necessarily a mudball. Typically, mudballs are a combination of media and floc forming a clump that doesn't break up during the backwash cycle. Record the size and depth that the mudballs are found in the media. Continue digging the hole until the beginning of the next layer of media is located and document the depth. Usually, a mixture of the two media will occur before a pure layer of the lower media (usually sand) is uncovered. Remove the media mixture until only the pure lower layer is in the hole, and measure the depth again to determine the depth of the interface. An interface of larger than 6 inches indicates the media may not be

properly matched OR that the final stage of the backwash cycle does not allow for adequate stratification. A large interface zone will have a smaller void ratio and can increase floc accumulation. Continue digging until all the media is removed from the hole and the gravel is exposed. Now, measure the total media depth.

### **Filter Coring (Step 10)**

Collect media for effective size (ES), uniformity coefficient (UC), specific gravity (SG) and floc retention analyses. To sample and evaluate various depths of the media, mark the coring device at 2, 6, 12, 18, 24, 30, and 36 inches (obviously dependent on the depth of your filter) with a permanent ink marker. Core samples are taken by inserting the coring device into the media down to the level of each mark. Carefully rotate the coring device in a small circle as it penetrates the media to enlarge the hole as the coring device is pushed down. Using a careful rotation will reduce the amount of upper layer media falling and contaminating the lower layer. Remove the coring device and place the end that contains the media into a ziplock bag and gently expel the media into the bag. On the ziplock bag that now contains the media, record the plant name, filter number, where in the filter (south side, etc.), date, depth of bore, and if the sample was collected before or after the backwash. Collect media in six locations in a 6 feet by 3 feet area to create a composite sample. Each sample is a composite of the same depth at six locations. In a filter with 36 inches of media, collect samples before and after a backwash from 0-2, 2-6, 6-12, 12-18, 18-24, 24-30, and 30-36 inches.

### **Bed Expansion (Steps 11-13)**

To determine the percent bed expansion, install the bed expansion tool into the filter box while the filter is draining. Completely drain the filter. Attach the  $\frac{3}{4}$  inch galvanized pipe to the end of the tool and place it on top of the media in a location where it can be firmly secured with a brace or cable ties to the safety railing along the side of the filter. Now, backwash the filter. Observe the tool and document the media expansion and backwash rate. Notice that the tool is usually not visible during the first low-wash and high-wash periods, but it may be visible during the second low-wash period. Document the rate and length of the entire backwash cycle. After the backwash cycle is completed, drain the filter and remove the tool. Determine the level to which the media rose (the media expansion) by observing the tallest tube filled with media. Calculate the percent expansion by dividing inches of rise by the total media depth. A bed expansion of between 25 and 30% is usually adequate to clean the media.

**Observe the Surface Wash (Steps 14-15)**

In a filter that has not been disrupted by either draining or coring procedures, observe the surface wash at the beginning of a normal backwash cycle. Document the type of surface wash system, the operating flow rate in gpm/ft<sup>2</sup>, water pressure, and the duration of the surface wash. Observe carefully how effectively the surface wash breaks up the floc on top of the media. As the water first rises above the media, note the effectiveness of the surface wash, the color of the water, when water reaches wash-water troughs, the distribution of the water as it flows over a trough, and the movement of floc particles. Vigilantly determine the distance from the top of the media to the surface wash when the filter is drained. The surface wash arms should be within 6 inches of the media.

**Backwash Turbidity Analysis (Steps 16-18)**

Collect backwash water samples every 30 seconds during the wash cycle for turbidity analyses. If the filter has two halves, collect samples from the uncored side so the data represents a typical filter wash. To collect samples for this analysis, lower a weighted, one-liter bottle on a string into the central wash-water trough. Have one person toss the bottle into the trough to collect the sample, while another person times the intervals and manages the sample bottles. The bottles can be weighted by duct taping a large washer or cap near the top of a plastic wide-mouthed bottle. As samples are retrieved from the wash-water trough, distribute them into pre-labeled 125 mL bacteria sample bottles. Analyze the samples for turbidity as soon as possible. Graph both the time and turbidity data. This data from the backwash turbidity analysis can be combined with the data from the floc retention analysis, bed expansion, and the individual filter run turbidity data to optimize both the backwash cycle's flow and duration.

Repeat this test on several filters before a new backwash cycle is determined to ensure a typical wash cycle has been documented. Seasonal variations in water quality and temperature may require periodic adjustment of the backwash procedures.

**Floc Retention Analysis (Step 26)**

Floc retention analysis is performed on the media collected with the core sampling device and is used, through the measurement of the amount of floc that is adhering to the filter media before and after the filter is backwashed, to determine if the wash cycle efficiently cleans the filters. To conduct this analysis, completely drain the filter and collect the core samples immediately while the media is wet and will adhere to the coring

tool walls. Place two pieces of  $\frac{3}{4}$  inch plywood each measuring 2 feet by 3 feet at the coring locations to stand on while collecting the core samples. Collect six core samples all around the plywood at depths of 0-2, 2-6, 6-12, 12-18, 18-24, 24-30, and 30-36 inches. If your media is greater than 36 inches, collect core additional samples in 6 inch increments. Place the media from each depth into an individual plastic bag to create a composite sample. Now, wash the filter. After the wash is concluded, completely drain the filter. Repeat sampling in the same location. Give the filter a short wash to re-stratify the media, and then place the filter back into service. Completely mix a composite silica sand media sample. Pour 50 grams of silica into a 50 mL beaker. Mark the side of the beaker to record the total volume of the sand. Use this mark to measure the volume of each media sample (anthracite and sand). If a balance is not available, use a volume of 40 mL. Place the media in a 500 mL Erlenmeyer flask. Add 100 mL of tap water close the top with a rubber stopper and shake vigorously for 30 seconds. Next pour the water into a 500 or 1000 mL bottle. Repeat the media and water mixing five times until the media has been washed by a total of 500 mL of water. Repeat this washing procedure for each core sample. Perform a turbidity analysis on each of the 500 mL water samples poured from the washed media samples. Multiply turbidity results by 2. The resulting NTU readings are the turbidity per 100 grams of sand. **Graph these results.**

- A turbidity of **30-60 NTU** indicates a clean filter as well as a ripened filter bed.
- Turbidity between **60-120 NTU** means the filter bed is slightly dirty but no cause for real immediate concern.
- Turbidity **above 120 NTU** means the filter bed is dirty and that both the filter washing system and filter washing conditions must be reevaluated.
- Turbidity **above 300 NTU** indicates a mudball problem.

Use the results from the washed media turbidity test and the backwash turbidity as guidelines to optimize the amount of water to be used during a wash cycle and to reduce turbidity spikes during the ripening period.

### **Filter Run Profile**

If individual filter effluent turbidity is not measured by on-line turbidimeters, samples must be collected manually. Using 125 mL bottles, collect samples at 1 minute intervals for the first hour of the filter cycle after it is brought back on-line and in 5 minute intervals for the next two hours or until the turbidity reaches its baseline value. Modify the sampling time intervals as needed, depending on the duration of each filter's ripening

period. An on-line turbidimeter is the most practical method to monitor the ripening period because of the frequency of grab samples required to document the startup spike. The disadvantage of an on-line turbidimeter is that the sample water entering the meter is diluted inside the sample cell so the size of a turbidity spike may not be accurately defined.

### **Conclusion**

By using these techniques to modify wash cycles, one treatment facility reduced the amount of wash-water used by 38%. These savings equate to millions of gallons of water per month. The improved backwashing protocol also decreased the necessary ripening period. A filter inspection program that includes the above described tests, done on a regular basis, can help a facility optimize the performance of its filters and identify problems.

This article appeared in the April 2002 edition of the AWWA publication, *Opflow* and was written by James F. Smith and Mark Swigert.

### **The expensive tools needed to perform a filter coring project.**

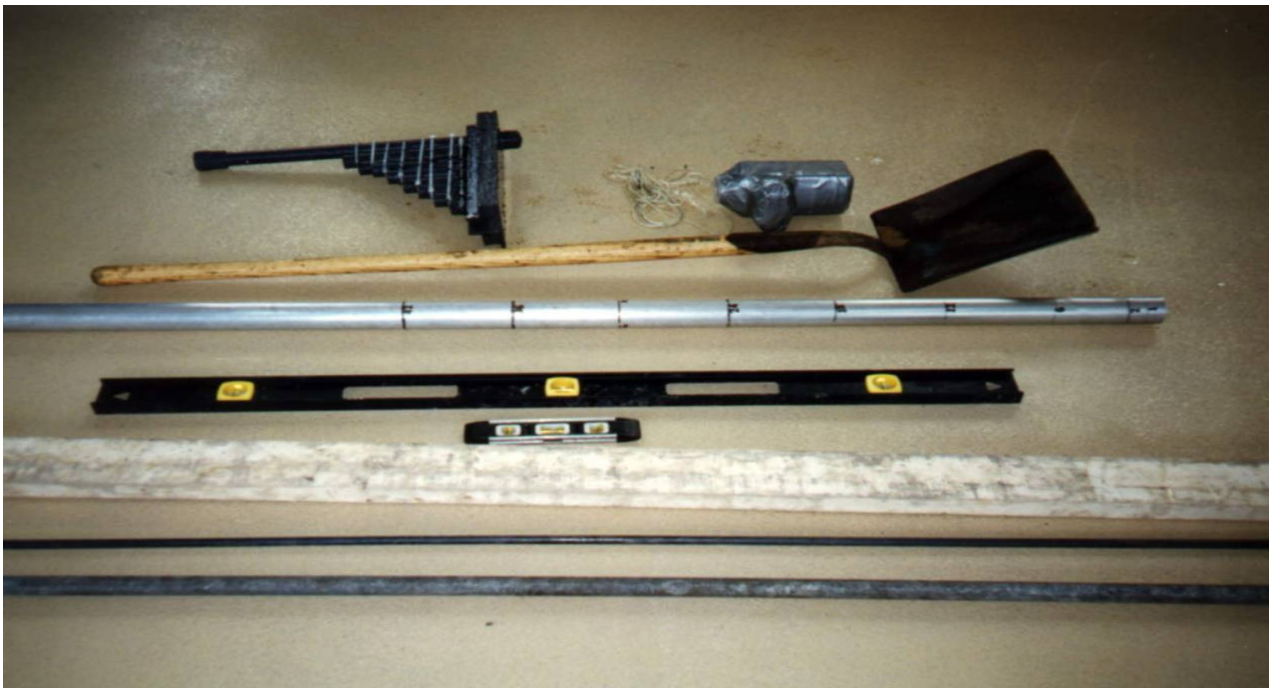





**A look at the media interface.**



### ***Filter Profiles***

Filter profiles are another way to determine just what is going on with the filter. These profiles can be accomplished by keeping an eye on gauges and notating the readings on a sheet of graph paper.

**C.) Filter-to-Waste time too short: Extend until Turbidity is < .1NTU. The filter-to-waste time for this plant was about 6 minutes; extending the filter-to-waste for another 6 minutes would have reduced the on-line turbidity to below .1NTU. It is important to note that many variables affect the amount of time needed for a filter to recover after backwashing. Consequently, it is likely that filter-to-waste times will often need to be adjusted. Therefore, it is important for operators to monitor turbidities and adjust/extend filter-to-waste until turbidities fall below the .1NTU goal.**

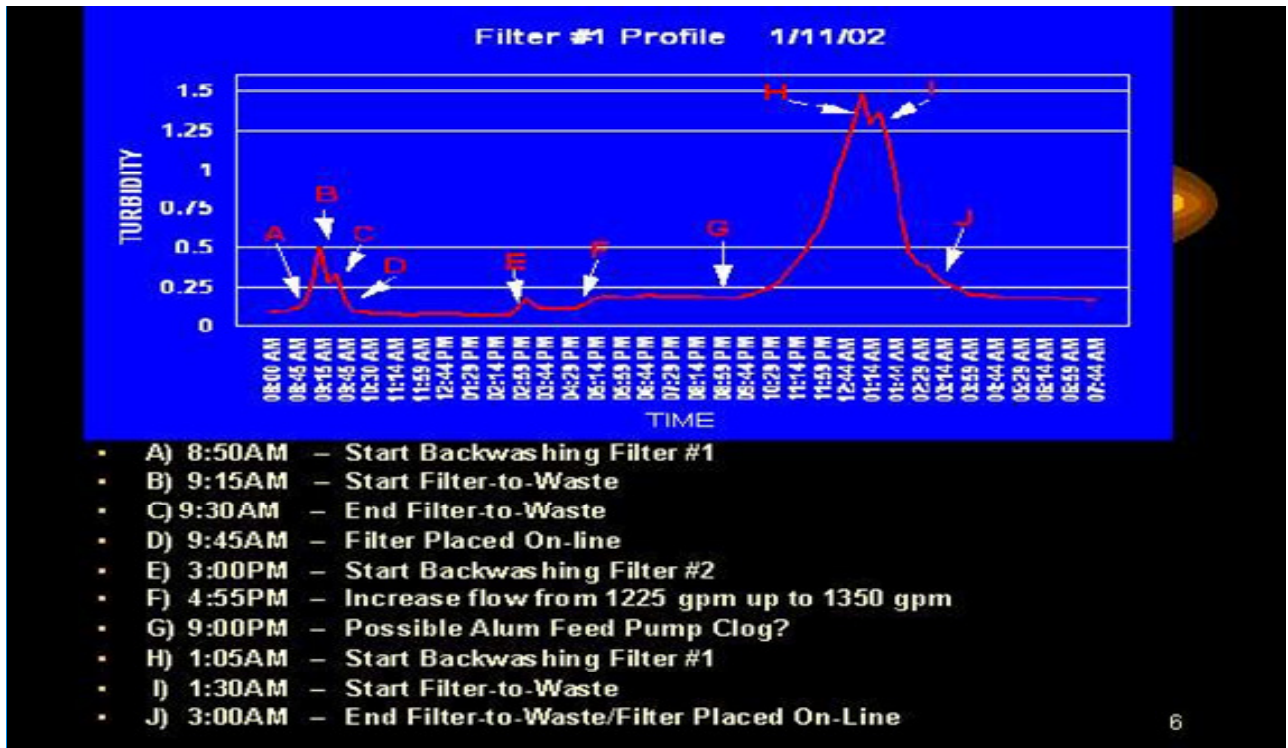
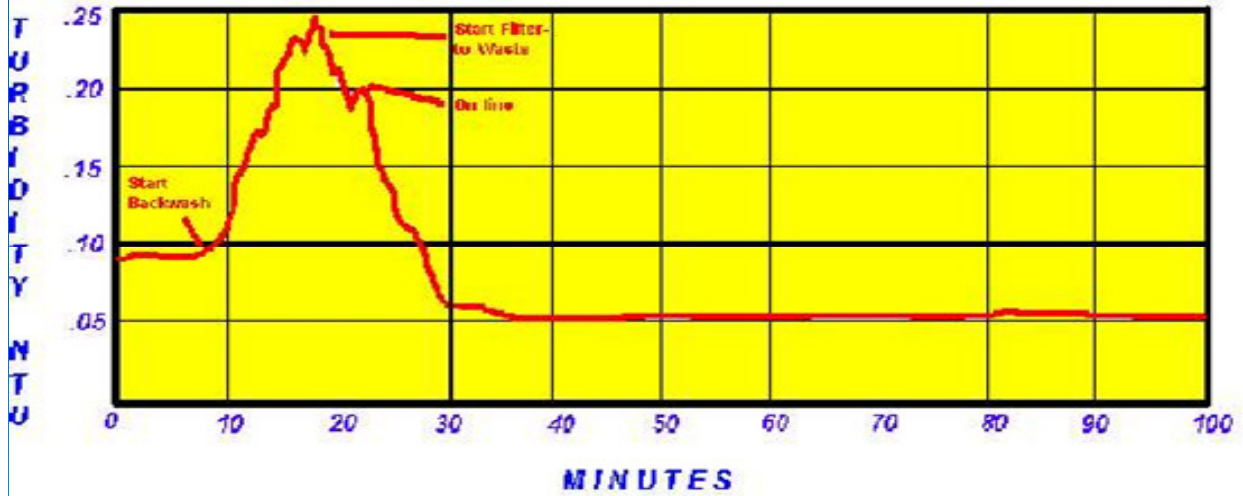

**D.) Secondary Spike:** Increasing filter-to-waste probably won't eliminate this spike. Possible solutions may include increasing backwash rates and/or duration of backwash, or allowing filter to "rest" off-line for at least 15 minutes before returning to service. Also, a plant may consider adding Alum to their backwash water during the last few minutes of the backwash sequence or adding a filter aid/polymer.

It is important to note that it is often not necessary for a plant to implement all of the above mentioned solutions. Evaluate the duration and severity of the backwash spike, then use some judgment when making recommendations.

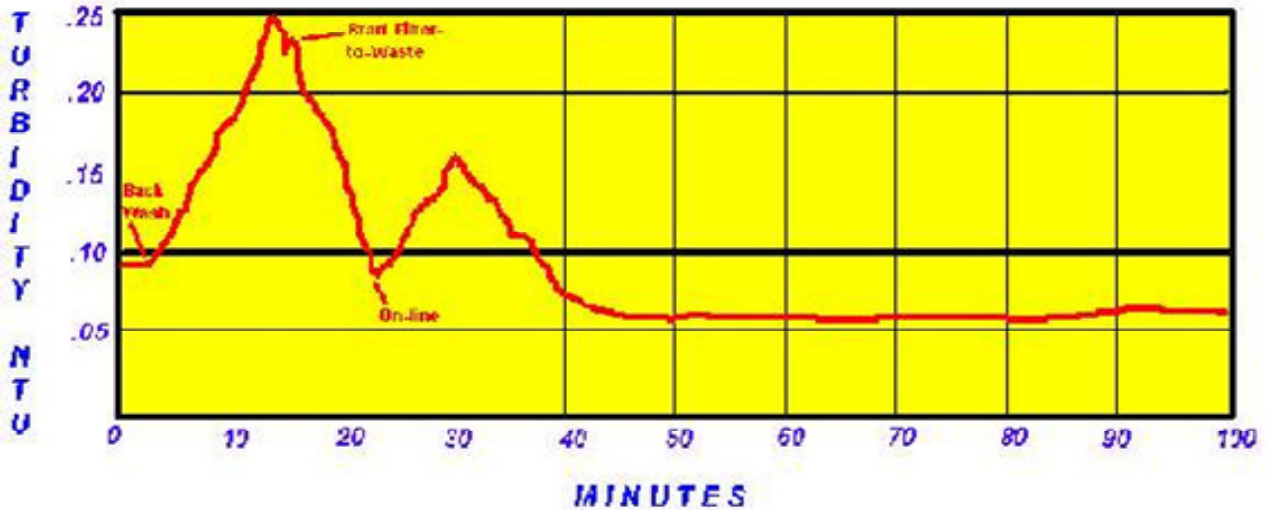

Some attention to detail and keeping an eye on the turbidimeter can yield surprising results by profiling the filter runs.

**E.) Excessive Recovery Time:** Something is significantly wrong with this profile. Begin by thoroughly evaluating the backwashing procedures and pretreatment chemical feeds. Look at the performance of upstream unit processes – rapid mix, flocculators, settling. Perform a thorough filter and media inspection. Try to determine where in the treatment process things are going wrong. Often, there are several causes combined; such as lack of rapid mixing + improper chemical dosages + excessive filter run-times + inadequate backwash rates. This type of profile is not always caused solely by poor filter performance.

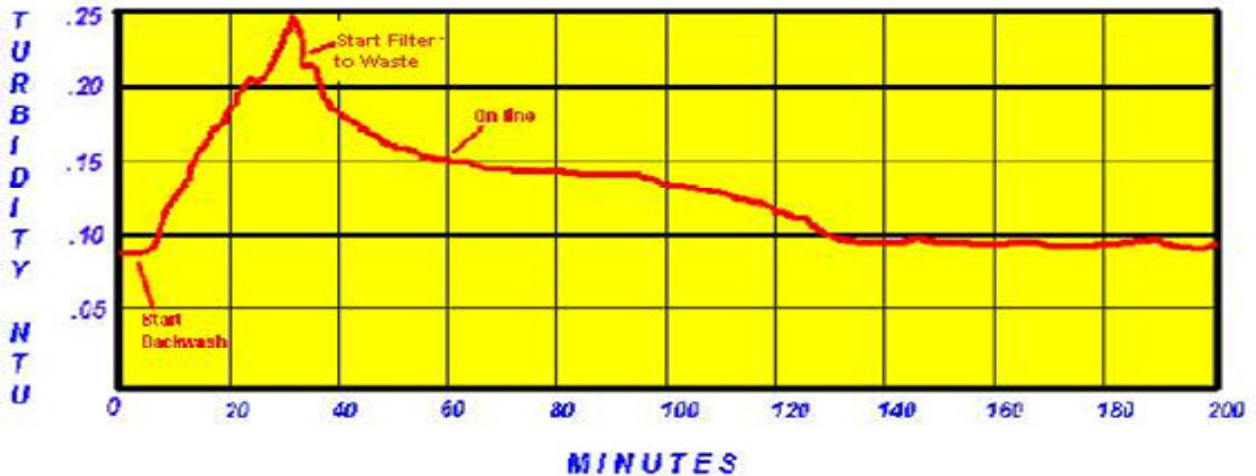

### ***Filter Media Cleaning***

If there is an issue with your filter media, replacing the media may not be necessary, it could just use a good cleaning. There are various methods to accomplish this and your fellow operators who have had this done are the best sources of information. In the years I have been doing this I have heard both sides of the argument.

There are two categories of filter remediation procedures:

#### **Physical**

- Labor Intensive
- Involves mechanical work in the filter bed.

#### **Chemical**

- Less labor intensive
- Sometimes involves the use of hazardous chemicals

The charts and graphs featured on the bottom of this page and on the next few pages display some results obtained by chemically cleaning filter media.

<b>Characterization of the Composition of Deposits for Dirty Media and Clean Media Soaked in Chlorine</b>							
	TSS mg/g	NSNV <sup>1</sup>		SNV <sup>2</sup>		V <sup>3</sup>	
		mg/g	%	mg/g	%	mg/g	%
Before backwash	8.86	4.02	45	3.39	38	1.44	17
After backwash	4.76	2.44	51	1.42	30	0.91	19
After backwash, after soaking in a chlorine solution	2.51	1.16	46	0.71	28	0.65	26

<sup>1</sup>NSNV – non-soluble, non-volatile

<sup>2</sup>SNV – soluble non-volatile solids

<sup>3</sup>V – volatile solids

|

<b>Characterization of the Composition of Deposits on Filter Media from Various Filters Before and After Being Soaked with Hydrogen Peroxide</b>							
FILTER MEDIA SAMPLES	TSS	NSNV		SNV		V	
	mg/g	mg/g	%	mg/g	%	mg/g	%
F 12 dirty	2.89	1.24	43	0.9	31	0.75	26
F 12 soaked in peroxide	1.28	0.17	14	0.74	58	0.37	29
F 13 dirty	7.09	4.09	58	1.54	22	1.46	21
F 13 soaked in peroxide	1.06	0.35	33	0.42	39	0.3	28
F 14 dirty	4.84	1.12	23	3.09	64	0.63	14
F 14 soaked in peroxide	0.99	0.03	3	0.53	54	0.43	44
F 26 dirty	0.86	0.17	20	0.38	44	0.31	36
F 26 soaked in peroxide	0.58	0.02	4	0.41	70	0.15	26
F 84 dirty	4.84	0.42	9	3.45	71	0.97	20
F 84 soaked in peroxide	1.46	0.39	27	0.55	38	0.52	36

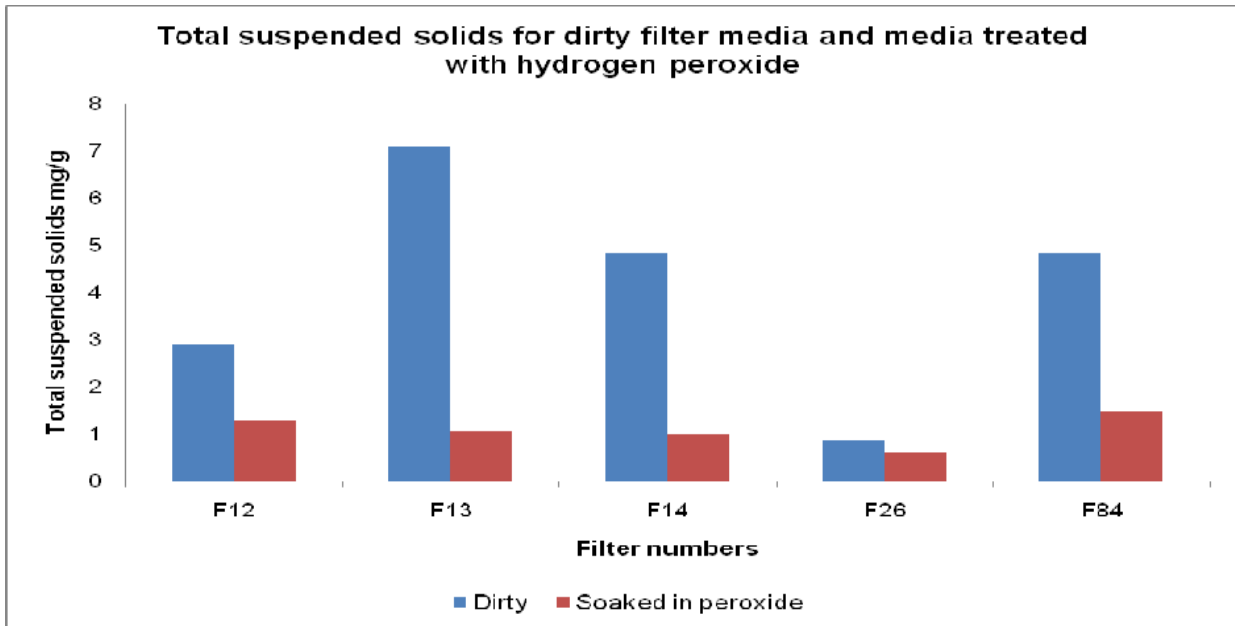

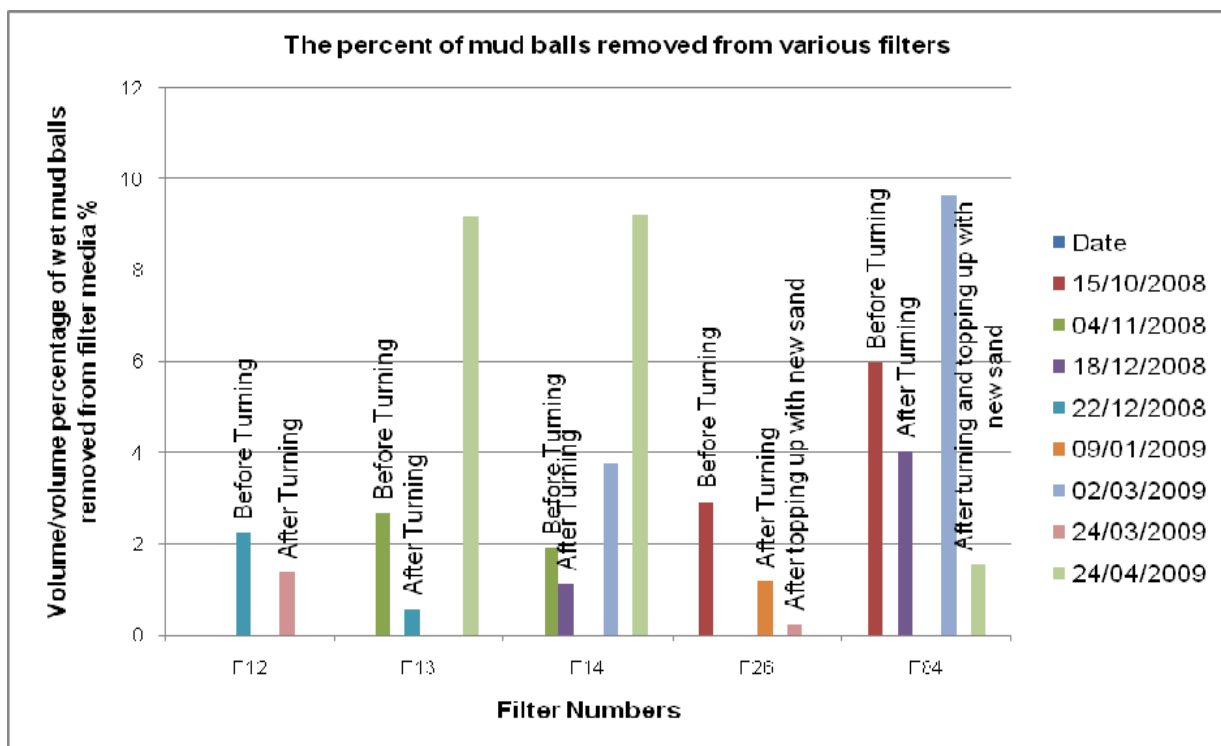

A **typical sodium hydroxide filter wash procedure** is outlined below. Site-specific applications may require modification of these guidelines.

1. Take filter out of service and drain down leaving some water on top of the anthracite.
2. Add sufficient sodium hydroxide to obtain a 2% solution in the water remaining in the filter, considering a void volume of 40% (40% of the filter media volume is water).
3. Allow the filter to soak preferably, air scour for at least for at least two hours. A longer cleaning cycle will generally produce cleaner media.
4. Initiate a normal filter backwash. Re-examine the media and, if necessary, repeat the cleaning procedure with a 1% sodium hydroxide solution.
5. The final backwash should be monitored (pH, turbidity) to ensure that all residue from the cleaning process has been removed. It may be necessary to extend the duration of the backwash cycle before putting the filter back into service.

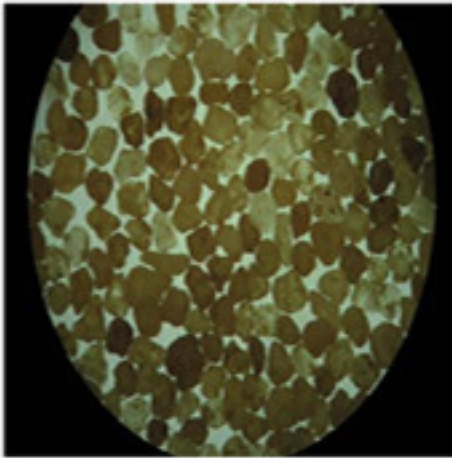

Dirty filter media with mudballs after the application of hydrogen peroxide to a final concentration of 10%

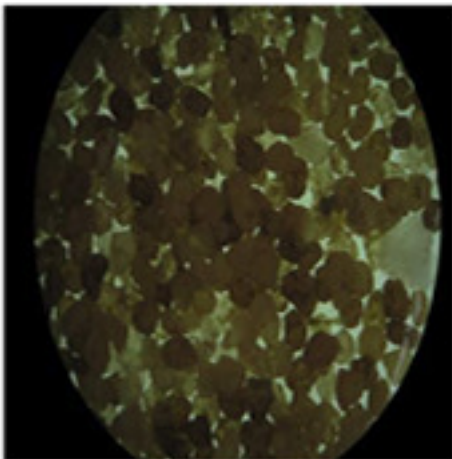

Dirty filter media with mudballs

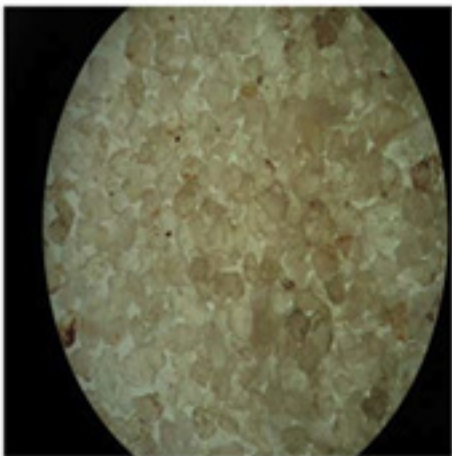

Clean filter media

***Review Questions for Chapter 8 - Filtration***

1. Pressure filters are a viable filter in surface water applications. T or F
2. Name three of the removal mechanisms of filters.
3. What are the two ways that contaminants end up being stored in our filters?
4. What are the three things to look for in filter media?
5. A ROF controller is used to maintain a \_\_\_\_\_ flow rate through the filters.
6. What can cause filters to air bind or lock?
7. Surface cracking or boils in the filter is usually a sign of what?
8. How can the number of mudballs in the filters be reduced?
9. If a filter has 36 inches of media and the media expands by to 44 inches after backwash, what is the percent expansion rate?
10. What is the recommended expansion rate of filters?
11. What is a filter profile?
12. What is filter coring?



***Answers to Review Questions for Chapter 8 - Filtration***

1. False
2. adsorption, straining, absorption, biological action
3. straining adsorption
4. effective size, uniformity, hardness, specific gravity
5. constant
6. high dissolved oxygen content, algae
7. uneven flow which could be caused by mudballs
8. surface wash
9. 22%
10. 20-50%
11. A filter profile charts a complete filter run to discover any signs of less than optimal filter performance
12. Filter coring exposes the different layers of the filter and the retention of floc to determine how well the filter is working.

This page left blank intentionally.

# Chapter 9: DISINFECTION

## Chapter 9 Objectives

1. Answer the question “Why do treatment operators disinfect the water”?
2. Define log removal, CT calculations, and breakpoint.
3. Determine at what range of proximity the disinfectant chlorine needs to be relative to a pathogen to impact it.
4. Decide how it is possible to determine whether or not breakpoint has been reached.
5. List the four forms of chlorine commonly used for the disinfection of water and their strengths and weaknesses.
6. Describe how UV accomplishes the task of disinfection.
7. Determine at what pH measurement the amount of hypochlorous acid is at its highest level.
8. Determine what factors affect disinfection.
9. Calculate dosage relative to demand and residual, lbs., dosage and ml relative to percent available disinfectant.
10. Define specific gravity.
11. Calculate gallons of chemical needed with a specific gravity both above and below 1.
12. Define and calculate percent solution strength.
13. Explain the significance of disinfection byproducts and determine the potential health effects of disinfection byproducts and how they are formed.
14. Determine what steps or practices could be undertaken to control or remove disinfection byproducts.
15. Determine what significance 2012 has relative to disinfection byproducts.

### ***Purpose of Disinfection***

- TO KILL or INACTIVATE PATHOGENS
- TO PROVIDE A RESIDUAL SAFEGUARD

The primary reason we disinfect our water is to kill or inactivate pathogens. Pathogens are disease causing organisms. Examples of diseases caused by waterborne pathogens are:

- Cholera
- Typhoid
- Salmonella
- Hepatitis
- Dysentery
- Polio
- Giardiasis
- Cryptosporidiosis

Waterborne illnesses in the past have eradicated entire populations and, even today, kill thousands of people every year. The treatment processes of coagulation, flocculation, and sedimentation that we use today were developed originally to remove or control pathogenic organisms in drinking water. Pathogens, which can take the form of bacteria, viruses, or protozoa, are not totally destroyed by disinfectants. Some of them are killed, some are temporarily inactivated, some are genetically mutated so reproduction is impossible, and some are not affected at all by the disinfectant in the time they are in contact with it. With possible life or death consequences a possibility, all our treatment processes, including disinfection, need to be fully optimized.



Pathogen Reduction from Various Treatment Processes	
UNIT PROCESS	PERCENT REDUCTION
Storage *	Significant Amounts
Sedimentation*	0 – 99
Coagulation *	Significant Amounts
Filtration *	0 – 99
Chlorination	99

\* These methods do not, by themselves, provide adequate pathogen reduction. However, their use prior to disinfection may significantly lower the costs associated with disinfection.

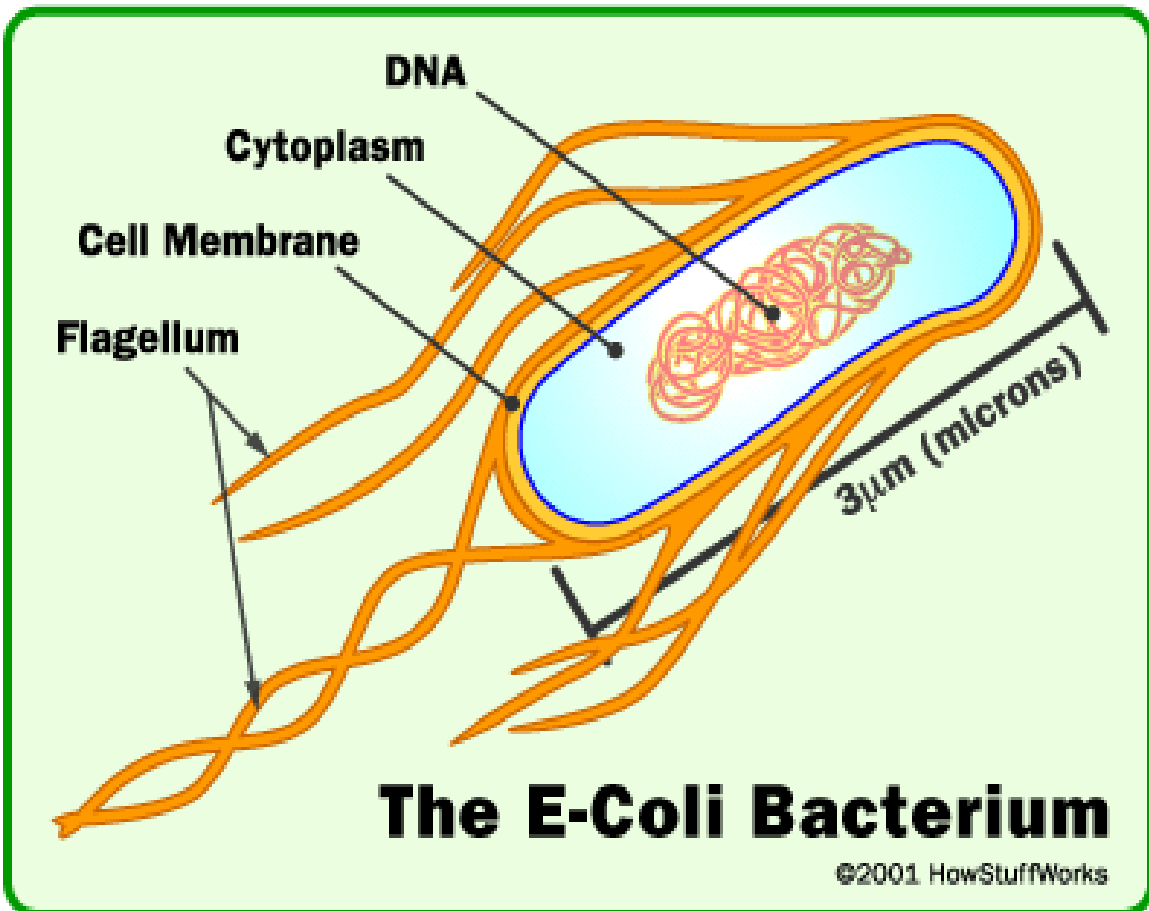

The secondary purpose of disinfection is to provide a residual safeguard. Water quality degrades after it leaves the treatment plant and travels through the distribution system on its way to the customer's tap. The amount of degradation is relative to the physical, chemical and biological composition of the treated water and, the physical, chemical and biological condition of the distribution system through which it travels, and how the treated water and the distribution system interact with each other. The disinfectant residual we impart to our distribution system hopefully provide a safeguard against pathogenic contamination that may originate or regrow within our systems.

We also sometimes use disinfectants as chemical oxidants. If fed early in the treatment process, the disinfectant pre-oxidizes certain compounds that are dissolved in the water allowing subsequent treatment processes to effectively remove these precipitated compounds. Pre-oxidation can aid in the treatment and removal of taste, color, odor, dissolved gasses and some disinfection byproduct organic precursors.

**401 KAR 8:150. Disinfection, filtration, and recycling. (The complete regulation can be located at [www.lrc.ky.gov](http://www.lrc.ky.gov).)**

Section 1. Disinfection. A public and semipublic water system shall provide disinfection, except as provided in this section. A semipublic water system shall comply with the requirements of this section for public water systems or meet the requirements of Section 2(2) of this administrative regulation.

(1) A public water system using groundwater or surface water as a source.

(a) A public water system that uses chlorine shall:

1. Use continuous automatic disinfection by chlorination;

2. Provide a minimum free chlorine residual of two-tenths (0.2) milligrams per liter, or ppm, throughout the distribution system measured as described in subsection (2) of this section;

3. Check free chlorine residuals daily at representative points throughout the system; and

4. Report the free chlorine residuals monthly pursuant to 401 KAR 8:020, Section 2(7)(a)2.

(b)1. Disinfecting agents other than chlorine may be used pursuant to 40 C.F.R. 141.172(c).

2. If chloramination is used, a minimum combined residual of five-tenths (0.5) milligrams per liter, or ppm, shall be provided throughout the distribution system.

(2) A public water system using surface water as a source or groundwater under the direct influence of surface water shall provide disinfection treatment as established in 40 C.F.R. 141.72(b).

(3) If a disinfection residual fails to comply with Section 1(1) of this administrative regulation, the public shall be notified in accordance with 401 KAR 8:020, Section 2(9).

(4) Variances or exemptions shall not be granted for subsection (2) of this section.

Section 4. Disinfection of Treatment and Distribution System Facilities, New and Repaired Water Lines. (1) New construction projects and line extensions.

(a) Disinfection. A water treatment plant or distribution system, including storage distribution tanks, or extensions to existing systems, shall be thoroughly disinfected before being placed in service.

(b) A water distribution system shall disinfect with chlorine or chlorine compounds in amounts that shall produce a concentration of at least fifty (50) ppm and a residual of at least twenty-five (25) ppm at the end of twenty-four (24) hours, and the disinfection shall be followed by a thorough flushing.

**Log Removal**



In addition to selecting the proper dosage to feed, the operator must determine if the amount of contact time is sufficient for the disinfection of pathogens. The ESWTR requires that the disinfection process be effective for a 3–log removal of Giardia cysts and a 4–log removal of viruses. In our business term “log” basically means 9. Hence a 2-log removal is 99%, a 3-log removal is 99.9%, and a 4-log removal is 99.99% and so on.



	<b>microorganisms removed</b>	<b>microorganisms remaining</b>
<b>2 log removal 99%</b>	<b>9900</b>	<b>100</b>
<b>3 log removal 99.9%</b>	<b>9990</b>	<b>10</b>
<b>4 log removal 99.99%</b>	<b>9999</b>	<b>1</b>
<b>Ruth Lancaster Illustration</b>		

Above is a delicious pitcher of Ohio River water during flood season. If there are approximately 10,000 microorganisms in the water and we started our disinfection process, a 2-log removal would leave 100 microorganisms remaining, a 3-log removal would leave 10 microorganisms, and 4-log removal would leave 1 microorganism. What percent of removal would you care to drink?

### ***Concentration Over Time (CT)***

Mathematical models were developed to assist the operator in determining how well their disinfection process meets removal or eradication standards. These models are the CT calculations. The CT takes into account all the factors that affect the viability of the disinfection process and determines the probability that the entire treatment process achieves the necessary removal or inactivation of pathogens in your water that would make it safe for human consumption. The “C” stands for residual disinfectant concentration and the “T” stands for contact time which are the two most important factors in the disinfection process. Among the criteria considered relative to CT could be:

- the performance of the coagulation/flocculation/sedimentation process,
- filter performance,
- what type of disinfectant is used,
- baffling,
- the pH and the water temperature,
- and the qualification of the operator.

After calculating CT, the necessary adjustments to the disinfection process can be performed that would reduce disinfection byproducts while still not compromising pathogen control so the water sent to our consumers is safe to drink. If the CT calculated is too high, disinfectant dosages could be lowered to achieve enough pathogen inactivation as well as keep disinfection byproducts to a minimum. Too low of a CT would mean the quality of the water has been compromised and a change would be necessary quickly in order not to jeopardize consumer’s safety. Possible CT enhancing changes that could be made to the treatment facility could be slowing down the flow of the water through the plant and allowing the plant to operate as it was designed, installing baffles in the basins to increase contact time, altering the treatment process so a lower pH could develop during disinfection contact and, lastly, increase the chlorine dose to meet CT.

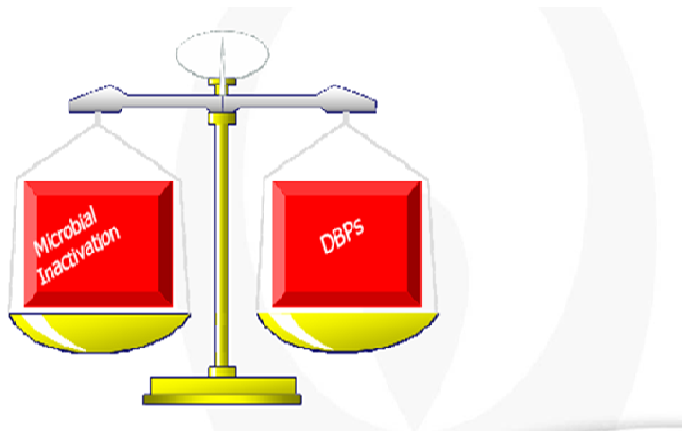



## ***Disinfectants Commonly Used in Potable Water Applications***

### Chlorine

The most commonly used disinfectant used for potable water. It is available in three forms and diluted forms are being used more frequently because of security concerns. Chlorine ( $\text{Cl}_2$ ) has shown its effectiveness in pathogen inactivation and also satisfies the need for a residual disinfectant safeguard against contamination in our distribution systems. As an oxidant, chlorine precipitates such substances as iron, manganese, prior to settling or filtration. It volatilizes gasses as hydrogen sulfide, methane and benzene and reduces many organic related taste, odor and color causing compounds. Because of its many forms, chlorine is available to be used in many applications, such as raw water, wells, pipelines, storage tanks as well as the many fittings used in the distribution system and in disinfecting water leak sites. With the advent of the information of the potentially carcinogenic properties of halogenated disinfection byproducts, due diligence is appropriate in the use of chlorine as a primary disinfectant. When chlorine is combined with organic compounds present due to a lack of treatment optimization or distribution system maintenance, Trihalomethanes (THM) and haloacetic acids (HAA5s) may be formed. THMs and HAAs are byproducts of the disinfection process. Because of the suspected carcinogenic properties, chlorine use as a pre-oxidant has declined and many facilities are using other means to oxidize their water.

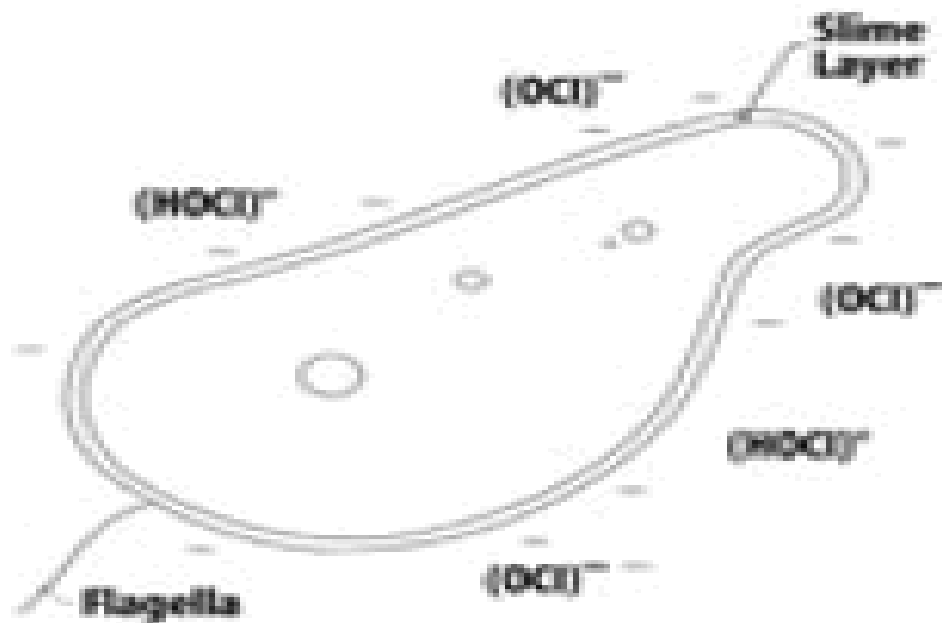

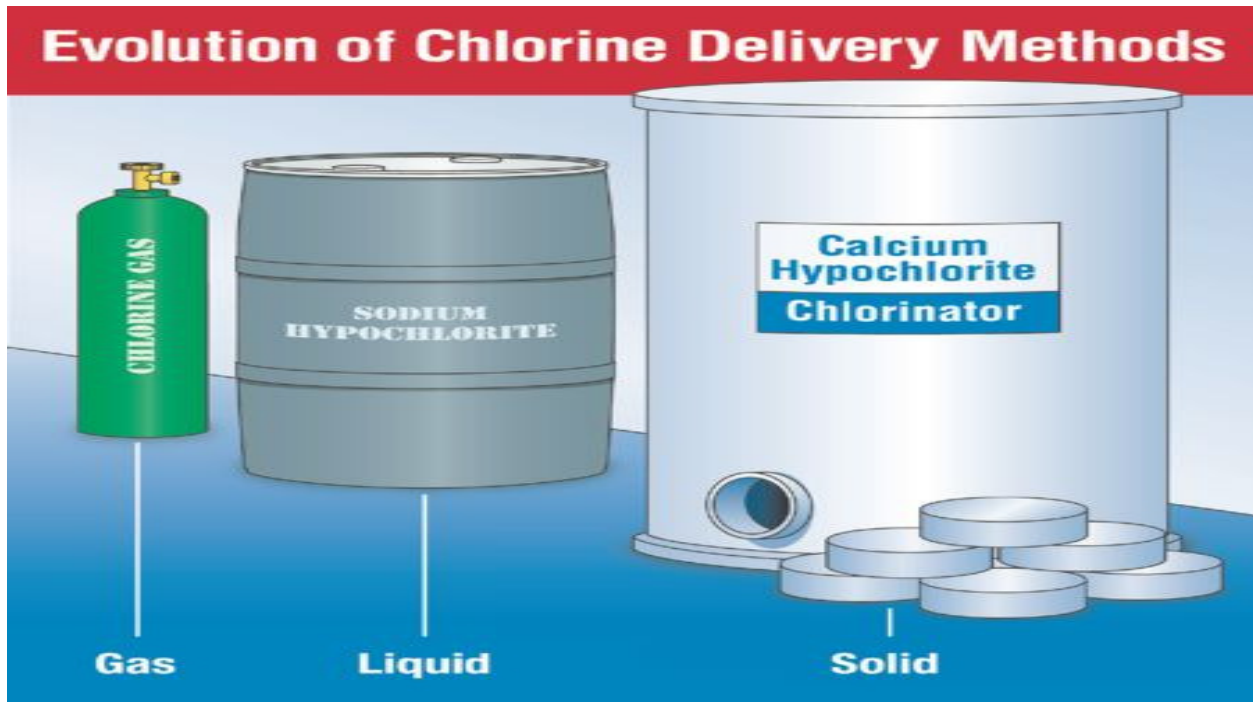

### ***Forms of Chlorine***

#### **Gas (100% available)**

Chlorine ( $\text{Cl}_2$ ) gas is fed out of pressurized tanks or cylinders that contain both a gas and a liquid. The amount of liquid to gas is temperature dependent with higher temperatures yielding a higher concentration of liquid. The atmospheric expansion ratio from liquid to gas is 460:1. Since liquid leaks are so dangerous, a fusible plug is designed to melt between 154° F - 165° F in order to exhaust the chlorine as a gas. Chlorine gas is a greenish – yellow color and is 2.5 times heavier than air. While chlorine gas is not flammable, as with oxygen it will support combustion. Chlorine gas is corrosive when in combination with moisture and has a tendency to lower the pH of the water. There are regulations in place regarding the chlorine room in a treatment facility to ensure the safety of the operators. Small leaks can be located with the use of a 10% ammonium hydroxide vapor solution that when in contact with chlorine gas produces a white cloud. When chlorine is fed at a rate of greater than 40 lbs. a day, freezing in the cylinder can occur. Every time a cylinder is replaced it is necessary to replace the lead washer to ensure the seal is air tight. Because of the potentially dangerous nature of chlorine, an up-to-date emergency response plan is necessary.

### **Calcium Hypochlorite (65 – 70%)**

This product is manufactured in a powder, granular, and tablet form. Many of us know this product as HTH which is a trade name. Calcium hypochlorite  $\text{Ca}(\text{ClO})_2$  tends to raise the pH of the water and is a weaker disinfectant than gaseous chlorine. Flammable hazards exist when in contact with oxidizers. This product should be stored in a cool, dark area because it degrades when exposed to light or heat and carries a shelf life of 2 years. It is frequently used in distribution system disinfection applications but more treatment facilities are using it as a primary disinfectant because of safety concerns concerning chlorine.

### **Sodium hypochlorite (5.25 – 15%)**

A liquid ( $\text{NaOCl}$ ) that is frequently referred to as bleach. Formerly used extensively in well systems and for the disinfection of distribution system pipes and fittings but more and more surface water treatment facilities are using sodium hypochlorite as their primary disinfectant. As with HTH, sodium hypochlorite should be stored in a cool, dark place because of the degradation effects of heat and light. This product has a shelf life from 60 – 90 days.

### **Chloramine ( $\text{NH}_2\text{Cl}$ )**

Formed by the addition of ammonia with chlorine. Chloramines are approximately 80 times weaker than chlorine gas as a primary disinfectant and it requires very long contact time to achieve pathogen inactivation. Chloramine lasts much longer in solution than chlorine with documented cases where it has shown to last for up to 27 days in the distribution system. Since the chlorine is in the combined form, the formation of THMs and HAAs is limited. Also, because chloramines never reach breakpoint, the minimum disinfectant residual for chloraminated systems is 0.5 mg/L. The chlorine to ammonia ratio, pH, and the rate of decay must be carefully monitored and controlled to prevent nitrification, taste and odor, increased lead and copper levels, and biological regrowth in the distribution system. Currently, Kentucky American and Louisville Water Company are using chloramines for disinfection.

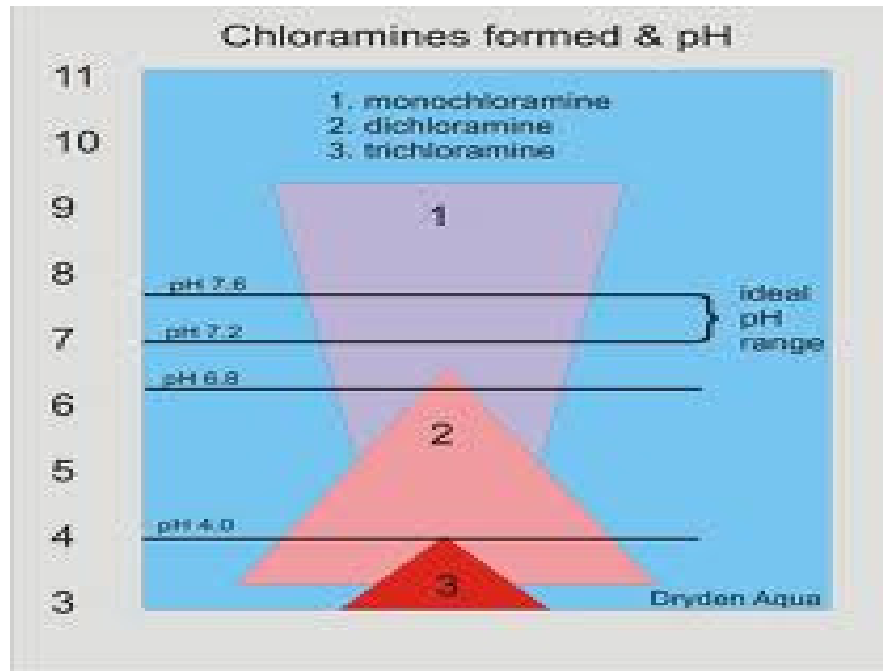

### Ozone (O<sub>3</sub>)

Ozone must be produced on site by subjecting oxygen molecules to a high voltage, low amperage charge. This action imparts a third oxygen molecule to the oxygen atom. It is an extremely strong oxidizer and the strongest disinfectant available for potable water treatment so CT can be easily met.

Ozone is sometimes used in conjunction with biologically active filters with granular activated carbon (GAC) media but this application requires a high level of operator attention. Ozone, like every disinfectant, produces its own disinfection byproducts, mainly bromate. The MCL for bromate is 0.1 mg/L which limits its use for some systems. Ozone used for disinfection can also form assimilable organic compounds which are low molecular weight dissolved organic carbons. Ozone, like chlorine, is corrosive when in contact with moisture. Ozone has been used for municipal water disinfection for over 100 years in Europe and one of the largest treatment facilities in the world, the 600 MGD Los Angeles Aqueduct Treatment Plant has used ozone for over a decade. Reduced coagulant dosages are a byproduct of ozone use in water treatment. Since ozone quickly dissipates, it cannot be used as a residual safeguard so its use must be supplemented with the use of chlorine or chloramine.

### Chlorine Dioxide (ClO)<sub>2</sub>

Chlorine dioxide, which results from the addition of sodium chlorite with chlorine, is a strong oxidant that may be used as a primary disinfectant. Because it does not form THMs or HAAs, chlorine dioxide may be fed early in the treatment process and used as a pre-oxidant. This makes it very useful in the control of iron and manganese, color, and many tastes and odors in the raw water. The ability to add the chemical early in the treatment process greatly reduces the CT required for pathogen inactivation. Chlorine dioxide produces its own disinfection byproducts, chlorite and chlorate, which must not be present as a residual greater than 1.0 mg/L before exiting the treatment facility. Because of this, chlorine dioxide has no use as a residual disinfectant and therefore must be supplemented with some other form of residual disinfectant. It must be generated on-site. Currently Dawson Springs and Henderson use chlorine dioxide as a disinfectant.

### Miox

Miox is an acronym for mixed oxidants. It is generated on-site with brine or salt subjected to an electrical charge. It is a strong oxidant and produces fewer halogenated disinfection byproducts (THMs and HAAs) than does chlorine. Reportedly, and from personal experience, Miox reduces biofilm formation in distribution system piping. The use of Miox as an oxidant also reduces coagulant dosages. Because all that is needed to produce this disinfectant is salt and electricity, safety concerns are minimal. Currently, Prestonsburg and Lawrenceburg use Miox as a disinfectant.

<b>TIME NEEDED (in minutes) TO ACHIEVE PATHOGEN INACTIVATION FOR FREQUENTLY USED DISINFECTANTS</b>				
<b>ORGANISM</b>	<b>FREE Cl<sub>2</sub> pH 6 - 7</b>	<b>Chloramines pH 8 - 9</b>	<b>Chlorine Dioxide pH 6-7</b>	<b>OZONE</b>
E Coli	.034 - .05	95 - 180	0.4 - 0.75	0.02
Polio	0.1 - 2.5	768 - 3740	0.2 - 6.7	0.1 - 0.2
Rotavirus	0.01 - 0.05	3806 - 6476	0.2 - 2.1	0.006 - .06
Giardia Lamblia	47 - 150		-----	0.5 - 0.6
Giardia muris	36 - 630	1400	-----	1.8 - 2.0
Cryptosporidium	7200	7200	79	5 - 10

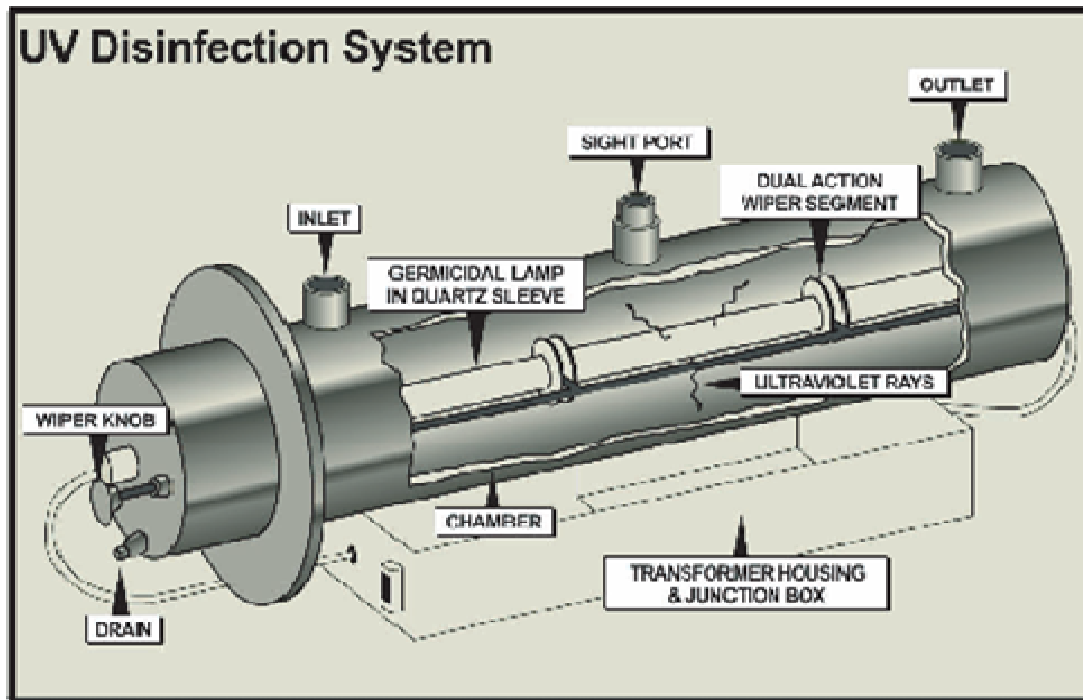

6.3 Figure 1: UV disinfection system

## UV

Ultraviolet radiation is being used more frequently for potable water disinfection. UV accomplishes the task of disinfection a little differently than most other methods. UV disrupts the DNA of the pathogen.

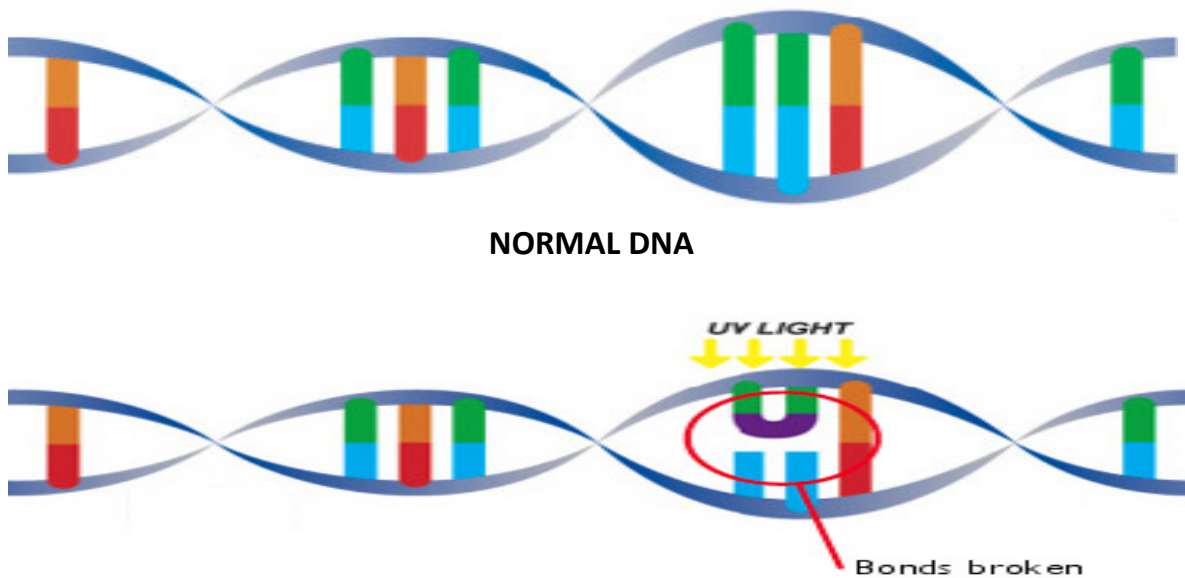

### **DNA AFTER UV EXPOSURE**

Ultraviolet is readily available as the bulbs used are glass enclosed mercury vapor lamps, similar to the lamps we use every day, but without an opaque coating. UV needs short CT's to accomplish disinfection and it produces no known toxic disinfection byproducts. The bulbs are encased in quartz tubes which are submerged in the flow. The success of the disinfection is dependent upon the ability of the light to permeate across the entire flow of water. To aid in this endeavor, wipers are outfitted on each quartz tube to ensure that it is always kept clean and allowing the light to reach as far as needed. There is no residual disinfectant generated with this process so it must be supplemented with some chemical disinfectant to impart a residual safeguard.

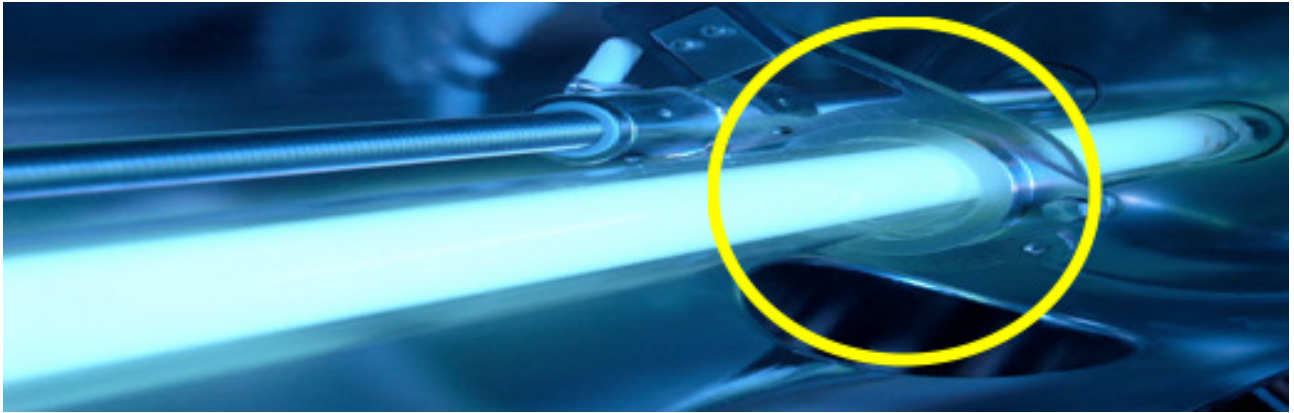

Currently Northern Kentucky Water and Shelbyville use UV.

There are other disinfectants available to be used in water treatment but as of this writing few others are used.

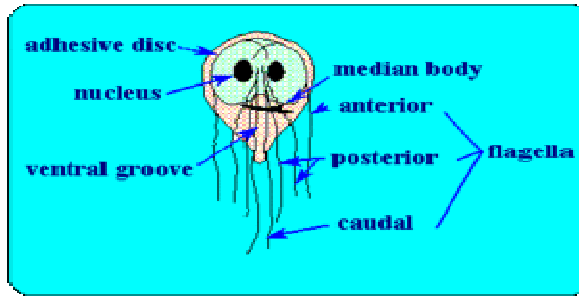

### *Disinfection Chemistry*

When chemical disinfectants, like chlorine, ozone, etc., are added to water they react with all the substances that are in the water. Since water is the universal solvent it chemically attracts all types of substances found in nature. Once these chemical reactions have completed, any remaining disinfectant in the water will exist as residual. If the water to be treated were free of all impurities, (i.e. distilled water), there would be nothing for the chlorine to react with. The chlorine added versus the chlorine residual relationship curve would be linear as shown below.

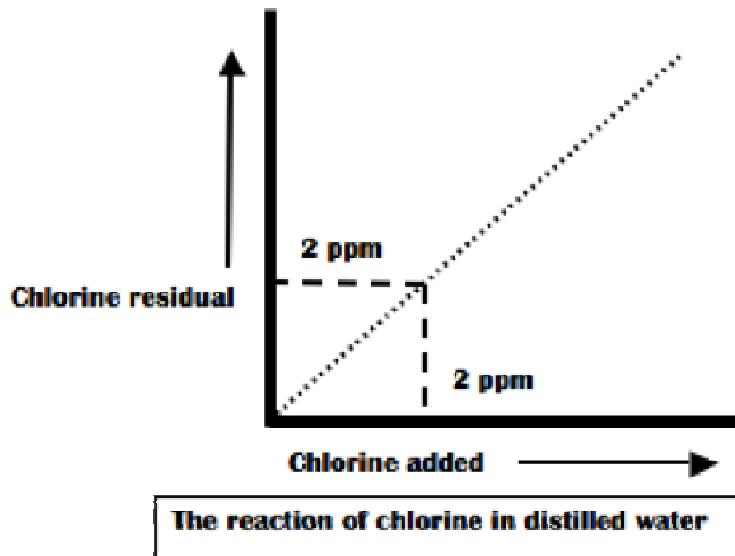



## Breakpoint

As an operator, we are faced with the task of treating natural water that is carrying substances that do react with the addition of chlorine. If we plotted the relationship of natural water and chlorine it would look like this.

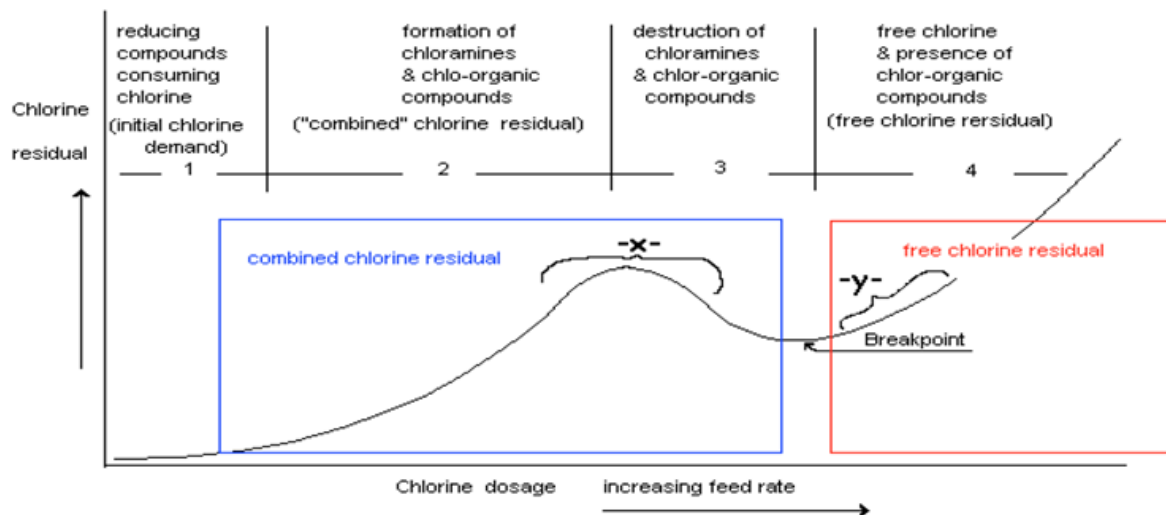

The curve at the bottom of the graphic above is commonly referred to as the **breakpoint curve**. The shape of the curve develops when we plot the chlorine added (dosage) versus the chlorine remaining (residual). From point 1 to point 2, the addition of chlorine results in no residual. At this point, the chlorine acts as an oxidizer where it precipitates dissolved substances (reducing agents) out of the water and is consumed via oxidation.

As more chlorine is added, from point 2 to point 3, chlorine reacts with the ammonia and organic matter in the water to form chloramines and chlororganic compounds. These are *combined* chlorine residuals. Since the chlorine is **combined** with other compounds, this residual is not free to react and therefore not available as free chlorine residual.

As more chlorine is added it results in a decrease of residual as the additional chlorine in the water oxidizes some of the chlororganic compounds and ammonia. This additional chlorine also changes some of the monochloramine to dichloromine and trichloromine.

As additional chlorine is added the amount of chloramine reaches a minimal value.

Beyond this point, the point is reached where the further addition of chlorine results in **free residual chlorine**. The point at which this occurs is known as the **breakpoint**. To the right of the breakpoint, an increase in the chlorine dosage will produce a proportionate increase in the residual. It is here where the curve begins to parallel the curve for distilled water, where the water has no demand for chlorine.

Another way to quickly determine whether you have reached breakpoint is to divide the residual chlorine reading by the total chlorine reading on your chlorine meter (DPD). If the chlorine meter shows a total chlorine of 1.2 ppm and a residual chlorine of 1.1 ppm, we would divide 1.1 by 1.2 and multiply the result by 100 to turn it into a percentage.  $(1.1 \text{ ppm} \div 1.2 \text{ ppm}) \times 100 = 91.66 \%$ . If this calculation results in a number near or above 85%, you are most likely at breakpoint.

The chlorine dosage fed into the water must not only meet the chlorine demand the water has, but also produce the desired residual safeguard. To accurately determine demand we can increasingly dose jars with chlorine and analyze the corresponding total residuals after an adequate contact time. The residuals are then plotted against their respective chlorine dosages to produce a breakpoint curve which will indicate to the operator the chlorine demand for that particular water. The desired residual is added to that demand to determine the proper dosage. The chlorinators should be set accordingly.

$$\text{DOSAGE} = \text{DEMAND} + \text{RESIDUAL}$$

One way to keep these three numbers into some perspective is to do what Ruth Lancaster related to me. Turn these three entities into a checkbook scenario.



**Dosage** will be the deposit put into your checking account.

**Demand** will be the amount of money spent by writing the checks to cover the expenses.

**Residual** is what is left over or the balance after all the checks are written.

<b>Dosage</b> (Deposit) = <b>Demand</b> (Expenses) + <b>Residual</b> (Balance)
--

<b>Dosage</b> is 3.5 ppm = <b>Demand</b> is 2.2 ppm + <b>Residual</b> is 1.3 ppm
--

As with any equation, if you know two of the variables you can determine the third.

If demand is 1.8 ppm and the dosage is 2.2 ppm then the residual is 0.4 ppm.

$$\text{Dosage } 2.2 \text{ ppm} - \text{Demand } 1.8 \text{ ppm} = 0.4 \text{ ppm Residual}$$

If dosage is 3.5 ppm and the residual is 0.8 ppm then the demand is 2.7 ppm

$$\text{Dosage } 3.5 \text{ ppm} - \text{Residual } 0.8 \text{ ppm} = 2.7 \text{ ppm Demand}$$

If demand is 2.9 ppm and the residual is 1.1 ppm then the dosage is 4.0 ppm

$$\text{Demand } 2.9 \text{ ppm} + \text{Residual } 1.1 \text{ ppm} = 4.0 \text{ ppm Dosage}$$

The regulated disinfectant residual required to be maintained throughout the entire distribution system is:

FOR CHLORINE                      0.2 mg/L (free chlorine)

FOR CHLORAMINE                0.5 mg/L (combined chlorine)

The purpose of maintaining residuals is to handle any disinfectant demand that comes about by way of the distribution system.

The quality of our consumable product (drinking water) is only as good as the container (our distribution system) it is delivered in. The quality of the treated drinking water is generally good to excellent when it leaves the water treatment facility. But as it travels from the treatment plant to the consumer, the quality of the water deteriorates relative to the condition of the distribution system. When distribution systems are exposed to the atmosphere, as in line installation or repair, contaminants can enter into our container (the piping). If the distribution system maintenance has been neglected, biofilms and other contamination can reproduce and flourish causing water quality issues. Our container, the distribution system, is basically a reusable container and effort needs to be given in the area of maintenance by performing such tasks as unidirectional flushing, storage tank and line disinfection, corrosion control, and backflow protection. Unfortunately, this is frequently an overlooked aspect of public drinking water systems.

When residual is lost in a distribution system, it signals an increase in disinfectant demand. This increased demand should be viewed as contamination developing in your system and the source or reason for this increase in demand should be located and eliminated immediately. Diagnostic residual analysis can be used to locate and identify this additional demand.

In the past, operators simply increased the disinfectant dosage at the plant to obtain a residual in the distribution system. This doesn't resolve any problems; the demand on the disinfectant is still there. Since biofilms are resistant to biocides, their numbers will continue to increase and also increase the disinfectant demand. Increasing disinfectant dosages will usually bring about a commensurate increase in disinfection byproducts, which will bring about compliance issues, and no additional protection against pathogenic contamination. A much better approach would be to eliminate whatever is causing the increase in disinfectant demand so that desired residual levels can be obtained at lower dosage levels and minimize potential disinfection byproduct increases.

The regulated maximum disinfectant residual level (MRDL) allowable by regulation is 4.0 mg/L for both chlorine and chloramine. This regulation was instigated to prevent the "old way" of achieving a disinfectant residual by throwing more disinfectant in the water at the plant and to encourage a "demand elimination" approach. Water quality degradation can be indirectly determined by calculating the disinfectant demand as shown previously. Loss of disinfectant residual in the distribution system is a result of greater demand. In order to control the disinfection process, the operator must control the factors that impact that process itself. It is important to understand not only what these factors are, but to also know how they impact the control of pathogenic organisms in our drinking water and distribution systems.

### ***Factors Affecting the Disinfection Process***

#### **Dosage**

The more disinfectant applied to the water within regulatory limits, the more effective the disinfection process will be. However, with chlorine, more disinfectant can lead to greater disinfection byproduct production. Excessively high concentrations of disinfectants can also affect corrosion rates, tastes and odors, and color issues. Because of the aforementioned reasons, it is important to determine what disinfectant level will achieve effective pathogen removal and continue to monitor to control this optimal level with correct dosage levels.

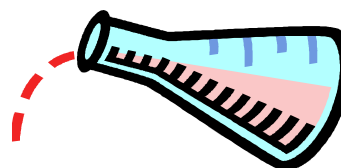

## Contact Time

The longer the contact time, the more effective the disinfection process will be. The disinfectant must physically come in contact with the pathogen or contaminant of concern so the longer the disinfectant has to react with the water, the more effective it will be whether it is used as an oxidizer or a disinfectant. Since organics in combination with chlorine will produce halogenated disinfection byproducts, THMs and HAAs, longer contact times could lead to greater disinfection byproducts production at a given dosage. Conversely, inadequate contact time between chlorine and water may not allow breakpoint chlorination to transpire which will reduce pathogen removal. Contact time and dosage are co-dependent upon one another. In order to achieve pathogen inactivation, CT calculations insure the proper combination of dosage to contact time.

**The effectiveness of depends primarily on two factors:**

- **Concentration (C)**
- **Contact Time (T)**

**THE DESTRUCTION OF ORGANISMS, OR “KILL”, IS DIRECTLY RELATED TO THESE TWO FACTORS AS FOLLOWS:**

**“Kill” is proportional to C X T**

Or

**“Kill” = C X T**

## Temperature

The warmer the water, the faster the chemical reactions will occur. Therefore, in the warmer summer months when the water is warmer, breakpoint chlorination and CT can be more rapidly achieved. Yet, because the dissipation of chlorine in the distribution system is driven by a chemical reaction, free residuals will be harder to maintain in the summer than in the winter when the water is cooler. A change in water temperature will change the disinfection characteristics of the treated water.



**pH**

When chlorine is added to water, the following chemical reactions take place:

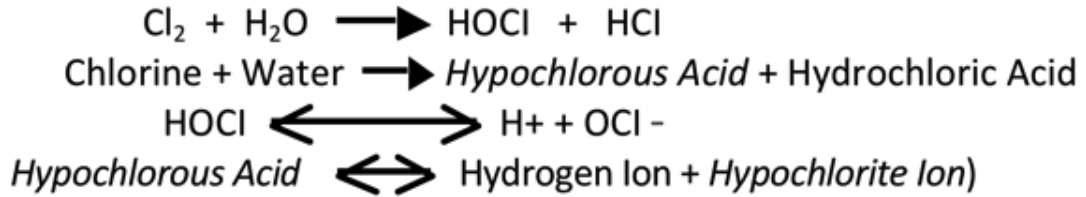

The Hypochlorous Acid and the Hypochlorite Ion are the compounds that kill or inactivate pathogens. Hypochlorous Acid is 100 X more effective at pathogen inactivation than is the Hypochlorite Ion. Both occur simultaneously in water with the relative concentrations of each being pH dependent. Generally, the lower the pH the greater the concentration of Hypochlorous Acid and because of the higher Hypochlorous concentration, the greater the disinfection potential. Waters with a higher pH will require greater chlorine dosages and/or longer contact times to achieve a given CT.

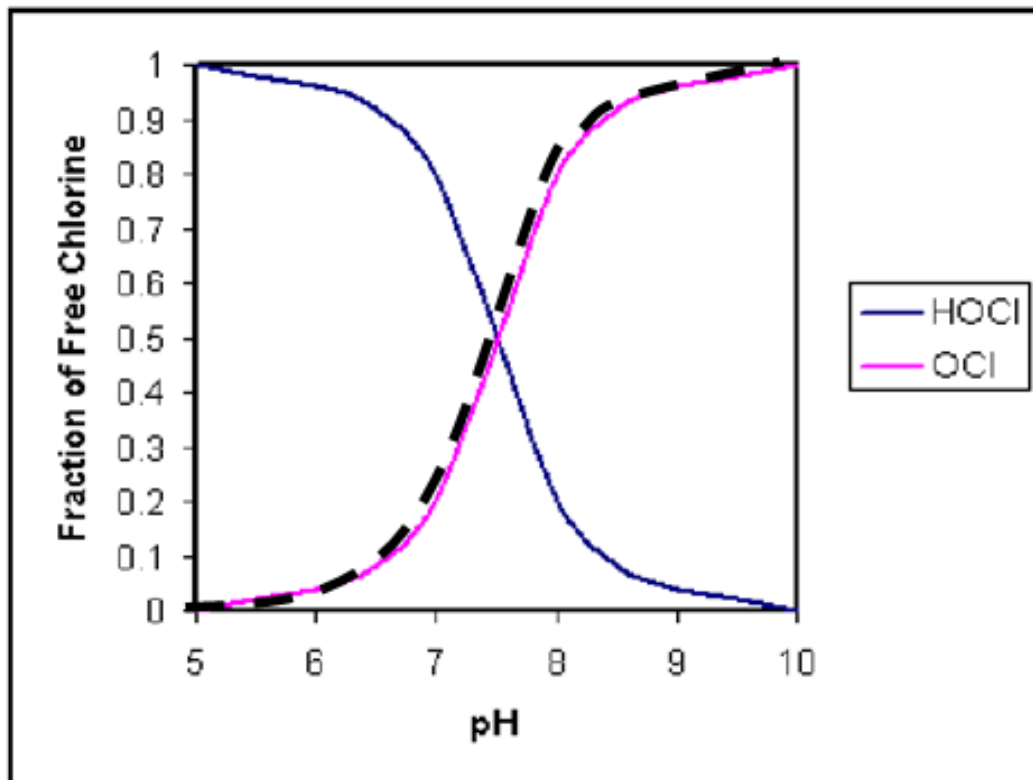

### The Effect on Free and Combined Chlorine Residual

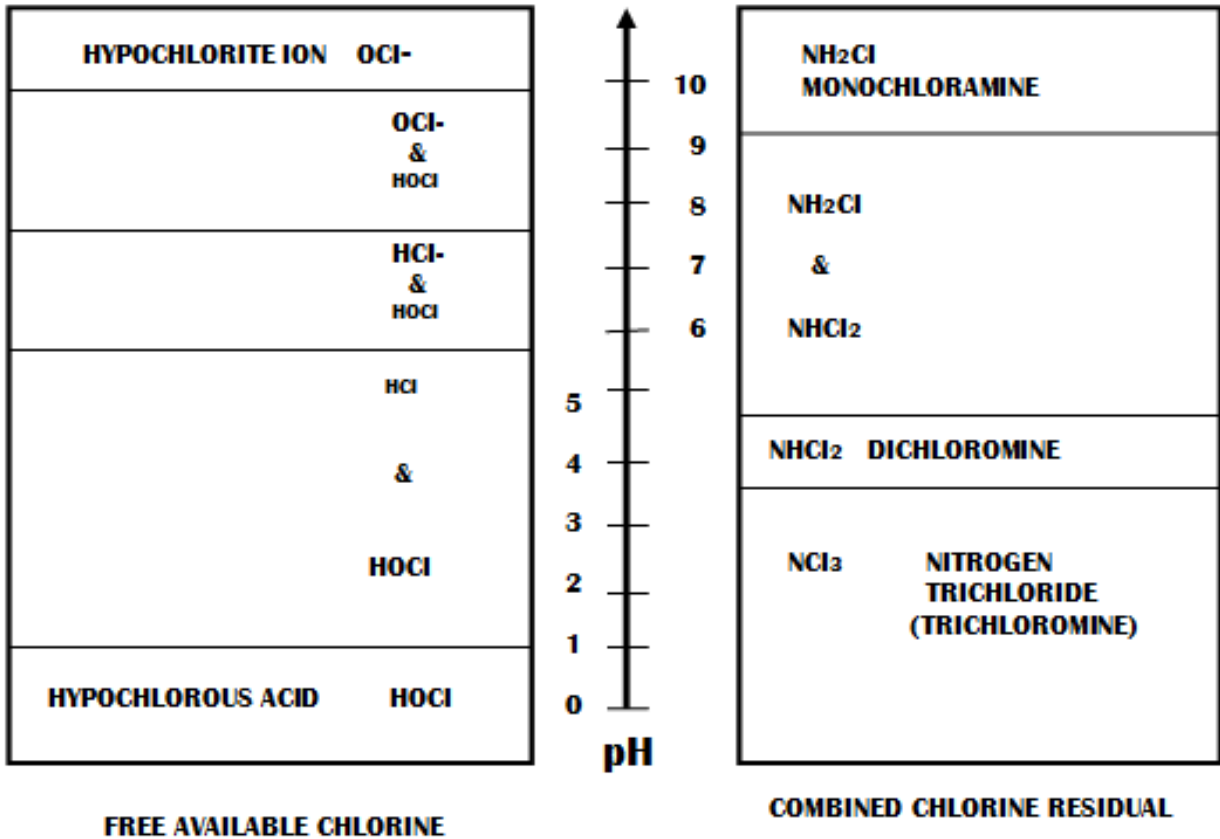

### Interfering Substances

Since disinfectants must physically come in contact with the pathogens we're concerned with, turbidity and other interfering substances can and do provide a barrier or shield that makes the survival of the pathogen much more likely. Some of these interfering substances can actually serve as a food source for pathogens. These interfering substances must be kept at a minimum. Turbidity reduction, unidirectional flushing, storage tank cleaning, etc. all assist in the optimization of our disinfection process.

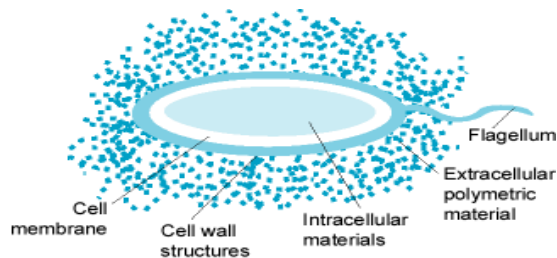

### ***Point of Application***

The point at which we apply our disinfectant is extremely important. If applied early in the treatment process, many of our disinfectants will provide oxidation characteristics which will greatly improve coagulation, settling or sedimentation, and filtration. Conversely, along with oxidation characteristics, early application of disinfectants may also increase disinfection byproduct formation. To minimize DBP formation, some operators will initially feed disinfectants post-filtration which is hopefully after TOC reduction which has been optimized through our coagulation, flocculation and sedimentation processes. If a free residual isn't carried through the filters, there is a high probability that pathogens stored in the filter can grow, multiply, and be released by the filter, making real pathogen control suspect. In order to maximize CT, chlorination should occur early in the treatment process while, simultaneously minimizing DBP production. With chloramination, chlorine is fed early in the treatment process to establish adequate contact time while taking advantage of the stronger disinfectant. Ammonia is then fed to produce the more persistent disinfectant residual. Chlorine dioxide and ozone are both fed early in the treatment process and supplemented later with chlorine or chloramine to provide the residual safeguard.

### ***Disinfection Monitoring and Control***

The amount of disinfectant applied to the water is water is dependent upon the **DEMAND**, which is a combination of the amount required to react with any reducing agents that are in the raw water, the amount that will combine with NOM present in the water, the amount of disinfectant needed to debilitate or destroy the pathogens present in the water and the desired amount of free residual required to control pathogenic contamination in the distribution system. The sum of **DEMAND** plus **RESIDUAL** equals the **DOSAGE** required. Initial demand can be determined with jar tests and DPD analysis. Subsequent adjustments of the disinfectant dosage are made because of fluctuations or changes in the raw water and your analysis of them. Breakpoint chlorination should be a mandatory practice to insure that all the demand is met and a free residual is established. Dosage can be calculated by using the following formulas.

$$\text{lbs./day} = \text{dosage (mg/l, ppm)} \times 8.34 \times \text{MGD}$$

if using a hypochlorite as your disinfectant, the percent purity must be accounted for

$$\text{lbs. of hypochlorite/day} = \text{dosage (mg/L, ppm)} \times 8.34 \times \text{MGD}$$

% purity



If we need to disinfect a volume of water, such as a basin, a storage tank, a pipe, etc., at a described or prescribed by regulation dosage, the formula would be:

$$\text{lbs. of disinfectant} = \text{dosage (mg/L, ppm)} \times 8.34 \times \text{MG}$$

If a measured amount, by weight, of a disinfectant is added to a known volume of water, the dosage can be calculated using the following formula:

$$\text{dosage (mg/L, ppm)} = \frac{\text{lbs. of chemical}}{8.34 \times \text{MG}}$$

Again, if a hypochlorite is used in this type of application, we must differentiate the percent purity from 100% available chlorine. That amount could be calculated as follows:

$$\text{dosage (mg/L, ppm)} = \frac{\text{lbs. of chemical} \times \% \text{ purity}}{8.34 \times \text{MG}}$$

***Examples:***

Roland disinfects their 8 MGD flow with a chlorine disinfectant concentration (dosage) of 2.5 ppm. **How many lbs. of disinfectant will this facility use in a day? How many lbs. an hour?**

$$\text{lbs. of chemical} = \text{ppm} \times 8.34 \times \text{MGD}$$

$$\text{lbs. of chemical} = 2.5 \text{ ppm} \times 8.34 \times 8 \text{ MGD}$$

$$\text{lbs. of chemical} = 166.8 \text{ lbs./day}$$

To determine how many lbs. an hour is used we just need to divide the total by how many hours are in a day.

$$\text{lbs. of chemical/hour} = \frac{166.8 \text{ lbs.}}{24 \text{ hours}}$$

$$\text{lbs. of chemical/hour} = 6.95 \text{ lbs./hr}$$

To determine the same type of equation using a hypochlorite solution, the calculation just needs to account for the percent purity. The Kays Treatment Facility disinfects their 900,000 gallon per day flow with a dosage of 3.5 mg/L of 12% sodium hypochlorite. **How many lbs. of sodium hypochlorite will this facility use in a day?**

$$\text{lbs. of chemical} = \frac{\text{ppm} \times 8.34 \times \text{MGD}}{\% \text{ purity}}$$

$$\text{lbs. of chemical} = \frac{3.5 \text{ ppm} \times 8.34 \times 0.9 \text{ MGD}}{.12} \quad (900,000 \text{ gallons} \div 1,000,000)$$

.12 (the decimal equivalent of 12%)

$$\text{lbs. of chemical} = \underline{26.27}$$

.12

lbs. of chemical = 218.9 or 219 lbs.

The Kays Treatment Plant needs to disinfect their sedimentation basin after removing all of the sludge by hand. As per regulation, the dosage needs to be an initial 50 ppm, held for a 24 hour interval and achieve a 25 ppm residual at the end of the 24 hours. The basin measures 30 feet by 75 feet and it is 12 feet deep. **How many lbs. of 70% available HTH would need to added to the water to disinfect their basin?**

$$\text{lbs. of chemical} = \frac{\text{ppm} \times 8.34 \times \text{MG}}{\% \text{ purity (decimal equivalent)}}$$

$$\text{lbs} = 50 \text{ ppm} \times 8.34 \times [(\text{width (ft)} \times \text{Length (ft)} \times \text{Depth (ft)}) \times 7.48 \text{ gal converted to MG}]$$

% purity (decimal equivalent)

$$\text{lbs.} = 50 \text{ ppm} \times 8.34 \times [(30 \text{ ft} \times 75 \text{ ft} \times 12 \text{ ft}) \times 7.48 \text{ then converted to MG}]$$

% purity

$$\text{lbs.} = \frac{50 \text{ ppm} \times 8.34 \times .20 \text{ MG}}{.70}$$

lbs. = 119.14 lbs.

Mr. Jones knows he has to disinfect the new line he and his crew have installed. His disinfectant tool is a grain scoop. If the scoop is full it will hold 2 pounds of 65% available calcium hypochlorite. The new pipe is 1500 feet long and is 8 inches in diameter. Mr. Jones used 1 1/2 scoops of HTH. **Did he reach his 50 ppm regulatory requirement?**

$$\text{ppm} = \frac{\text{lbs. of chemicals} \times \% \text{ Purity (decimal equivalent)}}{8.34 \times \text{MG}}$$

$$\text{ppm (mg/L)} = \frac{3 \text{ lbs.} \times .65}{8.34 \times [(.785 \times .666 \text{ ft.} \times .666 \text{ ft.} \times 1500 \text{ ft}) \times 7.48 \text{ gallons then converted to MG}]}$$

$$\text{ppm} = \frac{1.95}{8.34 \times 0.0039 \text{ MG}}$$

$$\text{ppm} = \frac{1.95}{.033 \text{ (actually 0.032526)}}$$

$$\text{ppm} = 59 \text{ (actually 59.090909)}$$

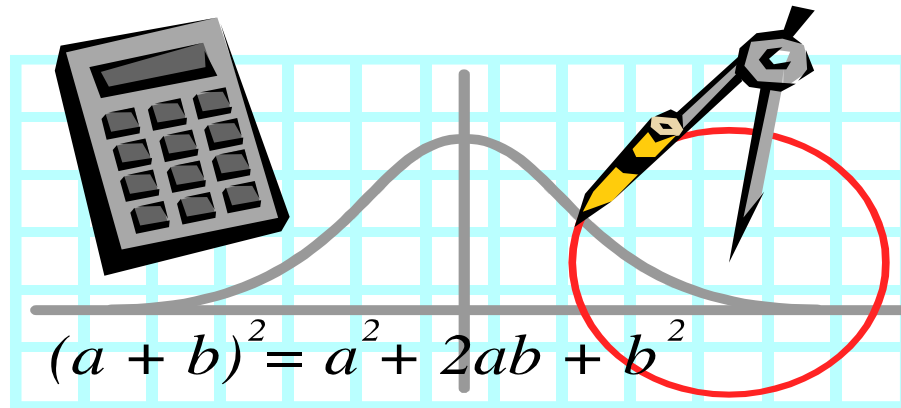

IF NO MENTION IS MADE OF PERCENT PURITY OR PERCENT AVAILABLE , DON'T WORRY ABOUT CALCULATING IT UNLESS IT IS MENTIONED IN THE BODY OF THE PROBLEM.

***Practice***

The Wilhoite Treatment Facility has a flow of 750 gpm during their 18 hours of daily operation. **How many pounds of chlorine will be needed to achieve their desired 3.75 ppm dosage rate?**

The Keatley Water Treatment Facility has switched from gaseous chlorine to sodium hypochlorite. This will be the first day they will use the 11% sodium hypochlorite in treating the 5.3 MGD flow at the plant to reach their desired dosage of 2.7 mg/L. **How many lbs. of sodium hypochlorite will they need to add to the water?**

The city of Ricketts treats 11.7 MGD and currently uses a dosage of 2.2 mg/L of chlorine. They have added on to their distribution system and now need a dosage of 3 mg/L to satisfy their residual requirements. **How many additional pounds of chlorine per hour will they need to accomplish this?**

The Haynes Treatment Plant is thinking of converting their disinfection from chlorine to 70% calcium hypochlorite. Their daily flow is 6 MGD and their dosage currently is 3.4 ppm. **How many additional pounds a month will they need to maintain their current dosage level and how much more expensive will the calcium hypochlorite be if they pay \$.80 a pound for chlorine and they will pay \$.48 a pound for the calcium hypochlorite?**

Where in the world do we start? I think we need to figure pounds for both and then do the costs.

1.                                    lbs. of chemical = ppm X 8.34 X MGD  
 lbs = 3.75 ppm X 8.34 X [(60 minutes X 18 hours X 750 gpm) converted to MGD]  
 lbs. of chemical = 3.75 X 8.34 X 0.81 MG  
**lbs. of chemical = 25.3**

2.                                    lbs. of chemical =  $\frac{\text{ppm X 8.34 X MGD}}{\% \text{ purity}}$   
  
 lbs. of chemical =  $\frac{2.7 \text{ ppm X 8.34 X 5.3 MGD}}{.11}$   
  
 lbs. of chemical =  $\frac{119.34}{.11}$   
  
 lbs. of chemical = 1084.9 or 1085

- 3.
- $$\text{lbs. of chemical} = \text{ppm} \times 8.34 \times \text{MGD}$$
- $$\text{lbs. of chemical} = (3 \text{ mg/L} - 2.2 \text{ mg/L}) \times 8.34 \times \text{MGD}$$
- $$\text{lbs. of chemical} = 0.8 \text{ mg/L} \times 8.34 \times 11.7 \text{ MGD}$$
- $$\text{lbs. of chemical} = 78.06 \text{ (for 24 hours of operation)}$$
- $$\text{lbs. of chemical/hr} = 78.06 \div 24 \text{ hours}$$
- $$\text{lbs. of chemical/hr} = 3.25$$
- 4.
- $$\text{lbs. of chemical} = \text{ppm} \times 8.34 \times \text{MGD}$$
- $$\text{lbs. of chemical} = 3.4 \text{ ppm} \times 8.34 \times 6 \text{ MGD}$$
- $$\text{lbs. of chemical} = 100 \text{ lbs. of chlorine @ } \$ .80/\text{lb.}$$
- $$\text{lbs. of chemical} = 3.4 \text{ ppm} \times 8.34 \times 6 \text{ MGD}$$
- $$\phantom{\text{lbs. of chemical} = 3.4 \text{ ppm} \times 8.34 \times 6 \text{ MGD}} \quad .70$$
- $$\text{lbs. of chemical} = 3.4 \text{ ppm} \times 8.34 \times 6 \text{ MGD}$$
- $$\phantom{\text{lbs. of chemical} = 3.4 \text{ ppm} \times 8.34 \times 6 \text{ MGD}} \quad .70$$
- $$\text{lbs. of chemical} = 170.1$$
- $$\phantom{\text{lbs. of chemical} = 170.1} \quad .70$$
- $$\text{lbs. of chemical} = 243 \text{ lbs. of 70\% calcium hypochlorite @ } \$ .48/\text{lb}$$
- |                               |                               |
|-------------------------------|-------------------------------|
| 243 lbs. calcium hypochlorite | \$116.64 calcium hypochlorite |
| <u>100 lbs. chlorine</u>      | <u>\$ 80.00 chlorine</u>      |
| 143 lbs. more                 | \$ 36.64 more                 |

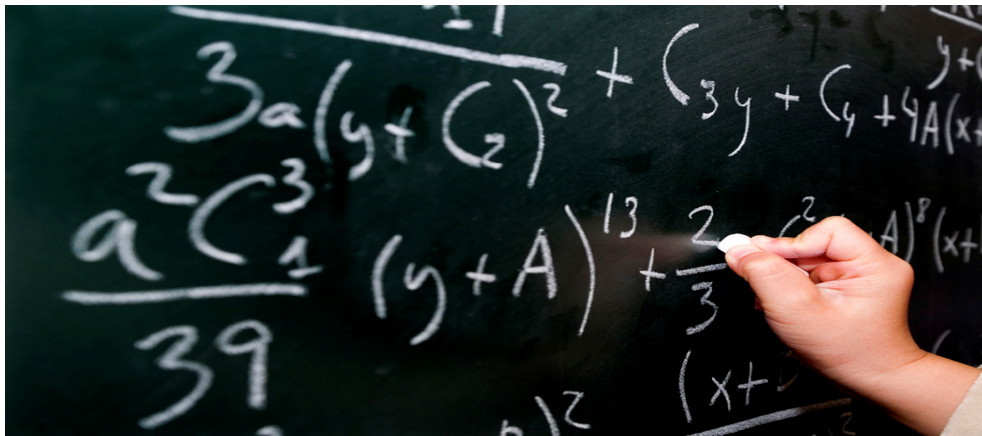

### ***Specific Gravity***

Specific gravity is nothing more than the weight of any liquid in comparison to an equal volume of water. Since some of the chemicals we need to treat our water do not weigh the same as water per an equal volume, we need to account for that difference since our formulas are based on the weight of water.

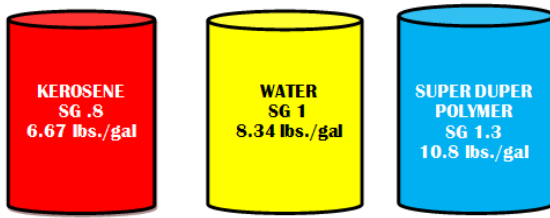

In the above illustration, kerosene has a specific gravity of 0.8 which means that it weighs .8 the weight of water or 6.67 lbs./gal (.8 X 8.34 lbs.). Our super duper polymer weighs 1.3 times more than water so it weighs 10.8 lbs./gal.

If we used a product that had a specific gravity of 1.6, what would it weigh a gallon?

$$8.34 \text{ lbs./gal water} \times 1.6 \text{ specific gravity} = 13.34 \text{ lbs./gal}$$

Example:

The Stump Treatment Plant disinfects their flow of 16.8 MGD with 8.25% available sodium hypochlorite with a specific gravity of 1.8 to obtain a dosage of 3.3 mg/L. **How many gallons of sodium hypochlorite will the plant use a day?**

All of our dosages are based on weight so to determine gallons we have to determine pounds first.

$$\text{lbs. of chemical} = \frac{\text{ppm} \times 8.34 \times \text{MGD}}{\% \text{ purity}}$$

$$\text{lbs. of chemical} = \frac{3.3 \text{ ppm} \times 8.34 \times 16.8 \text{ MGD}}{.0825}$$

$$\text{lbs. of chemical} = 462.37 \text{ lbs.}$$

$$\text{gallons of chemical} = \frac{462.37 \text{ lbs.}}{(8.34 \times 1.8 \text{ SG})}$$

$$\text{gallons of chemical} = \frac{462.37}{15 \text{ lbs./gal}}$$

$$\text{gallons of chemical} = 30.82 \text{ or } 31 \text{ gallons of sodium hypochlorite}$$

***Strength of Solution***

Strength of solution is the weight of a chemical divided by the weight of the water it was put into PLUS the weight of the water called the solution. When the calculation is performed you will have a decimally notated number that when multiplied by 100, will give you an answer in a percentage notation.

$$\text{Strength of Solution} = \frac{\text{weight of chemical}}{\text{weight of solution}}$$

Example:

If we were to put 25 pounds of alum in 300 pounds of water, we could calculate it in this way.

$$\begin{aligned}\text{Strength of Solution} &= \frac{25}{300 \text{ lbs./water} + 30 \text{ lbs. alum}} \\ \text{Strength of Solution} &= \frac{25}{330 \text{ lbs.}}\end{aligned}$$

Strength of Solution = 0.075  
turned into a percentage multiply the sum by 100

$$\text{Strength of Solution} = 7.5 \%$$

Harrod Treatment Plant has added 77 lbs. of caustic soda to 1000 gallons of water. What is the percent strength of solution?

$$\text{Strength of Solution} = \frac{77 \text{ lbs. of caustic}}{1000 \text{ gallons of water} + 77 \text{ lbs. of caustic}}$$

$$\text{Strength of Solution} = \frac{77 \text{ lbs. of caustic}}{(1000 \text{ gal} \times 8.34 \text{ lbs./gal}) + 77 \text{ lbs. caustic}}$$

$$\text{Strength of Solution} = \frac{77 \text{ lbs. of caustic}}{8417 \text{ lbs. of solution}}$$

Strength of Solution = 0.009 decimally or 0.9%

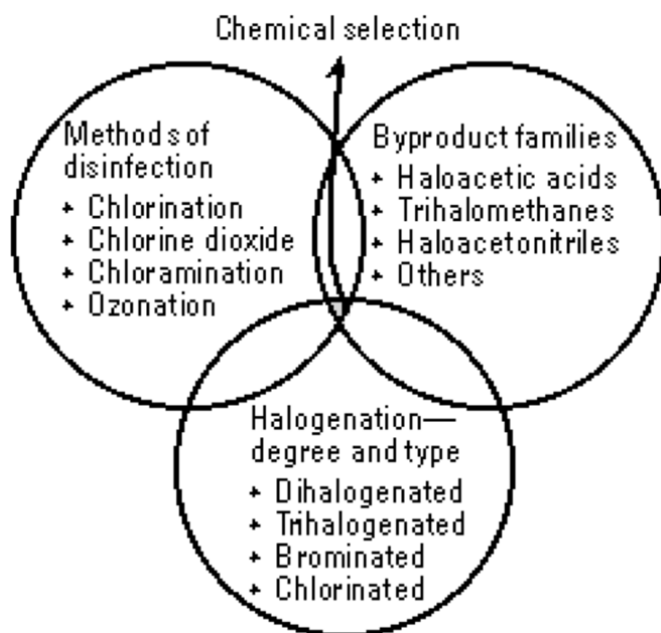

### ***Disinfection Byproducts***

Disinfection byproducts (DBP) are formed when disinfectants used in water treatment and distribution react with natural organic matter (NOM). The main DBP that regulations have been established for include:

- S trihalomethanes
- S haloacetic acids
- S bromate
- S chlorite

#### **Trihalomethanes (THM)**

Trihalomethanes are a group of four chemicals that are formed when chlorine reacts with organic matter present in the water.

chloroform

bromodichloromethane

dibromochloromethane

bromoform

The Disinfection Byproduct Rule 2 sets the maximum allowable annual average **at 80 ppb**.



### **Haloacetic Acids (HAA)**

These are also referred to as HAA5 because five different acids are formed when chlorine comes in contact with water.

monochloroacetic acid

dichloroacetic acid

trichloroacetic acid

monobromoacetic acid

dibromoacetic acid

HAA5 are regulated at an annual average of **60 ppb**.

### **Chlorite**

This is formed when chlorine dioxide is used as a disinfectant.

Chlorite is regulated at a monthly average of **1 ppm**.

### **Bromate**

Bromate is formed when ozone reacts with naturally occurring bromide found in source water. It is regulated at an annual average of **10 ppb**.

I am aware that this is redundant but it warrants repetition. pH can dramatically impact the reactions between chlorine and NOM. resulting in very favorable conditions for the formation of total trihalomethanes (TTHM) and haloacetic acid (HAA). At a higher pH, more THM tend to form. Lower pH tends to favor HAA formation. Systems that have high TTHM levels but relatively low HAA formation might be able to reduce TTHM formation by lowering the pH. If your facility chooses this course of action pay close attention to potential corrosion issues.

Besides the regulatory issues, DBP have been shown to be potentially carcinogenic, or cancer causing, so their control is in everyone's best interest. There are means available to control these substances, some of which do not require substantial investments of time or money. Optimizing the entire treatment process from beginning to end most probably reduce the precursors of disinfection byproducts, the organics, and allow your facility to meet regulatory guidelines, meet CT standards so viable disinfection is achieved, and protect your consuming public. Being successful in this regard requires attention to detail, operator diligence, and in some systems, more management support.

*Microbial Inactivation & Disinfection by-product (DBP) Formation*

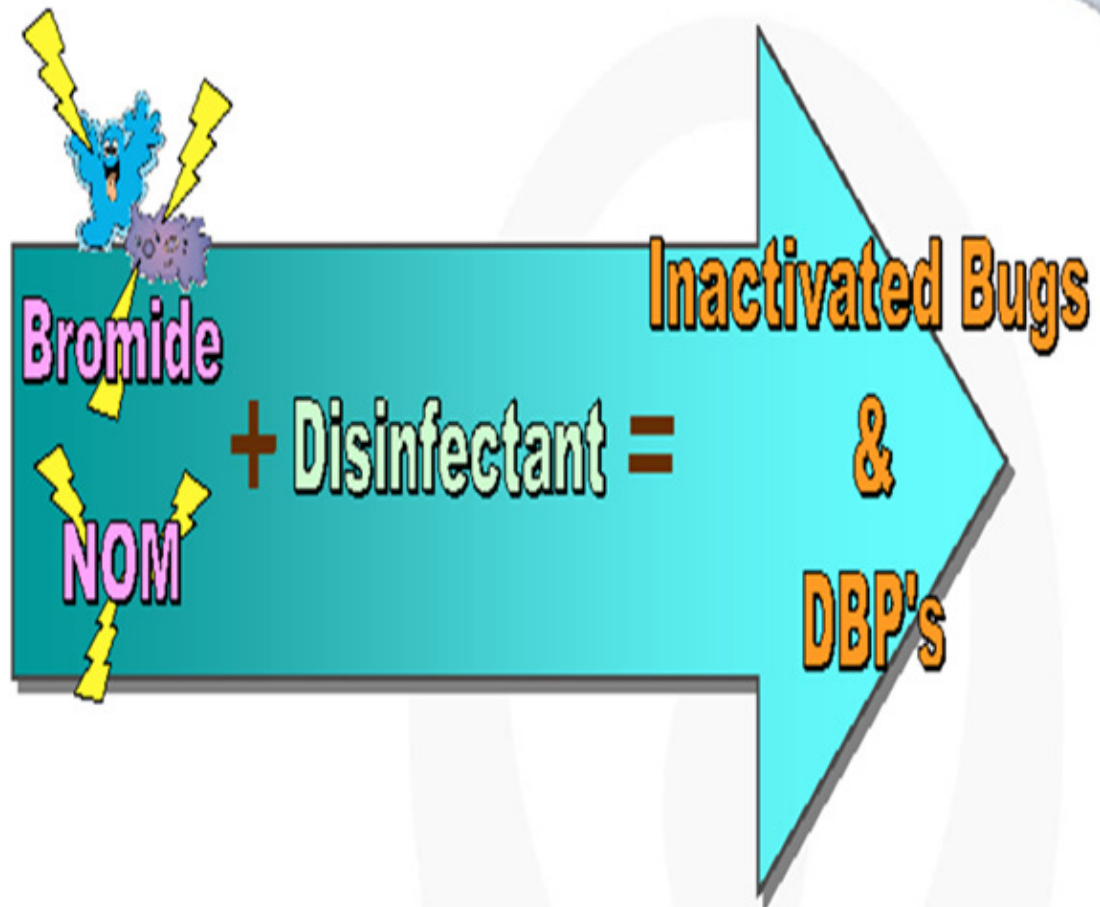

DBPs form due to disinfectant chemistry or from combining with natural organic matter (TOC)

***Review Questions for Chapter 9 - Disinfection***

1. Describe the reasons that disinfection of water is necessary.
2. Identify why a residual disinfectant in the distribution system is mandated by regulation.
3. Identify the three types of chlorine commonly used in municipal drinking water treatment
4. Chloramines are formed when what two substances are combined?
5. What is the strongest disinfectant used in drinking water treatment?
6. Describe the process by which UV accomplishes disinfection.
7. Rate these chemical disinfectants from strongest to weakest: sodium hypochlorite, chlorine dioxide, gaseous chlorine, ozone, calcium hypochlorite, ozone, and chloramines.
8. Explain how an operator determines that chlorine in the water has reached breakpoint.
9. Identify the things that interfere with disinfection.
10. Which is the more effective disinfectant, hypochlorous acid or the hypochlorite ion?
11. Explain the relationship between chlorine disinfection and pH level.
12. If you get customer complaint calls about the water smelling like Clorox, does this usually mean that there is too little or too much chlorine in the water?
13. If a liquid has a specific gravity of 1.4, is it lighter or heavier than the same volume of water?
14. TTHMs are formed when what two substances come in contact?
15. Could the point of application of chlorine make a difference in the production of DBPs?

***Answers to Review Questions for Chapter 9 - Disinfection***

1. kill pathogens, provide residual safeguards
2. to kill any pathogens or to prevent pathogenic growths to flourish and reproduce
3. gaseous chlorine, calcium hypochlorite, sodium hypochlorite
4. chlorine and ammonia
5. ozone
6. changing or damaging the DNA of the pathogen which prevents the pathogen from replicating or reproducing
7. ozone, chlorine dioxide, gaseous chlorine, calcium hypochlorite, sodium hypochlorite
8. If the free chlorine is  $\geq 75\%$  of total and when all the chlorine added to the water shows as free chlorine.
9. turbidity, dosage, time, temperature, pH
10. Hypochlorous acid is 100 times a stronger disinfectant than the hypochlorite ion.
11. Low pH
12. If the water smells like Clorox, USUALLY this means that you haven't reached breakpoint and more chlorine is needed.
13. A specific gravity of 1.4 means that the liquid is 1.4 times heavier than water.
14. TTHMs are formed when free chlorine reacts with organics.
15. yes

# **Chapter 10: BACTERIOLOGICAL MONITORING**

## **Chapter 10 Objectives**

1. Circumscribe the reason that sampling is mandated by regulation.
2. Notate the minimum number of samples required by regulation.
3. Determine the method that can be used as a substitute for chlorine residual sampling.
4. Explain why samples should be representative of your system.
5. Determine when check samples are necessary and where should they be taken.
6. Determine what volume of water is need for a bacteriological sample, the hold times for Bac-T samples and how long these records need to be kept.
7. Notate the hold times for bacteriological samples.
8. List what tests are performed to determine the presence of coliforms in the finished water.
9. Define coliforms, why they are used in our industry, and how sampling is changing relative to coliforms.
10. Define heterotrophic plate counts, standard plate counts, what they enumerate and why can be a valuable tool.

### ***Purpose***

Bacteriological sampling is used to determine potential contamination problems, allowing the system to notify the public to boil their water while operators can locate and rectify the cause of the problem. Pathogens are disease causing organisms that have decimated entire populations and cultures. The pathogens of interest are bacteria, viruses, and protozoa. To determine if the propensity or likelihood that pathogens are present in our water we use an easy, inexpensive method to determine how likely the presence of pathogens might be. We use an indicator organism called a coliform. Coliforms are found in the intestinal tract of warm blooded animals but effective disinfection inactivates these organisms. Coliforms are easy to grow and relatively cheap and easy to identify. The total coliform rule (TCR) is being revised as of this writing so changes in sampling could be shortcoming. If coliforms are present, there is a strong likelihood that pathogens are also present.

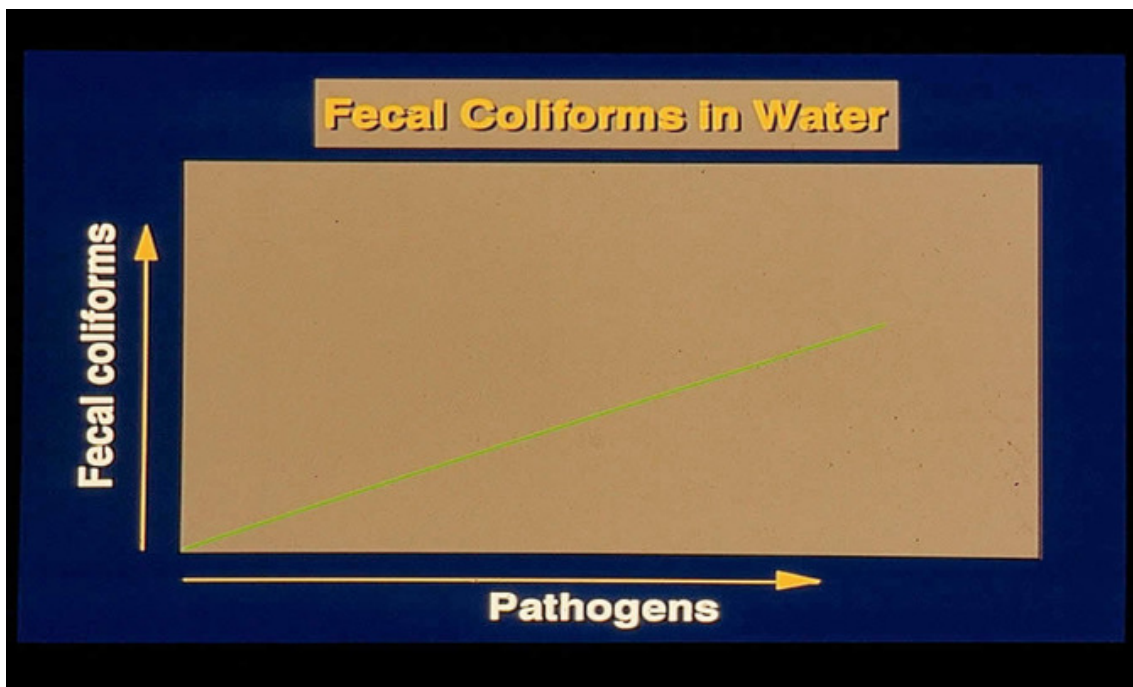

If fecal coliforms or E. coli are present in your water, an immediate boil water and public notice must be issued.

COLOR WHEELS MAY NO LONGER BE USED FOR COMPLIANCE SAMPLING.

## ***Requirements***

ALL public water must take samples of their water. **The minimum number of samples that any system, no matter how small, can take is two (2).** The population of your system will dictate the number of samples that need to be taken. If your system collects forty (40) or less samples a month, ALL must be negative to stay in compliance. If your system collects more than forty samples, the system can have 5 % of the samples test positive without the system being out of compliance. A heterotrophic plate count (HPC), or as it is sometimes referred to, a standard plate count can be used in lieu of chlorine residual for up to 5 % of the distribution system samples.

## ***Collection***

**At least 100 milliliters (ml) of water** must be collected in, hopefully, a sterile container. Compliance samples should not be collected from fire hydrants, water fountains, hoses, or swivel or leaky faucets. When using faucets for sampling, the faucet should not contain strainers or screens. The sample water should be run in at least pencil-sized streams for two – three minutes or until the temperature of the sample is constant. The reason for the two – three minute criteria is to insure that the sample being taken is not from premise plumbing but rather from the distribution system mains. The most numerous reasons for positive samples are operator error that could result from a lack of knowledge or a lack of concern by the operator. In the bottom of the collection bottle is usually found a small white tablet or a small amount of white powder. These substances are sodium Thiosulfate that is used as a dechlorination agent to determine what is left in the sample water after it has been exposed to the systems disinfection efforts.

## ***Representative samples***

Samples should truly represent the quality of the water throughout the system. Water taken from “safe” sample points do nothing except satisfy compliance numbers. The sites that should be sampled are the dead ends, low use areas, and the older lines that have been in service for a long time. Failure to sample the potentially problematic areas is to not diligently perform the duties of a certified operator which is to protect the consuming public, all the consuming public. As the system expands, update the sampling plans to reflect these changes. Sampling plans should include residential, commercial, industrial, and educational sample points. An addition or revision of your sampling sites must be done in writing to the DOW and approved before use. If a sampling site is abandoned or the site itself is no longer physically available, the number for that former sampling site may not be reused. When a water sample is taken and comes back negative, all it means is that at that sample location and at that time, the water was safe. Immediately before or after the sample was taken the water could have been contaminated.

### ***Check Sampling***

After the notification from the lab of a positive sample, a system **must collect three (3) check samples**. One from within five upstream service connections, one from within five downstream service connections and one from the original sampling site.



Check samples are till considered compliance samples. If a system collects fewer than **five (5) samples a month** for compliance, the month after a check sample incident, the system **MUST submit five (5) compliance samples**. Special samples like new line installation, line extensions, etc., do not count toward compliance but must be specified as a special sample. Even though they are not compliance samples, they too must be submitted on bacteriological analysis report forms (BARF's). Be sure to protect yourself and the system and include an accurate chain of custody document with each set of samples.

### ***Hold times***

Total coliform samples have a **30 hour hold time**.

Heterotrophic (standard) plate counts have a **six hour hold time**.

### ***Methods***

Multiple Tube Fermentation

Membrane Filtration

MMO-MUG

Heterotrophic Plate Count (Standard Plate Counts)

These are required for compliance samples that are **below the minimum chlorine residual of 0.2 mg/L**. This test counts the number of bacteria, not coliforms, not pathogens, only bacteria. Counts must be **less than 500 colony forming units per 1 ml of the sample**.



### ***Record keeping***

Again, always fill out the **BARF** and chain of custody paperwork. These bacteriological records must be kept for a period of at least five (5) years. On all chain of custody and BARFs **always include**:

- Collection date and time
- Location code chlorine residual
- Type of disinfection
- Name, address, and PWSID
- The signature of the sampler

***Review Questions for Chapter 10 – Bacteriological Monitoring***

1. The minimum number of samples any size system is regulated to obtain is \_\_\_\_.
2. A HPC can be used in lieu of a chlorine BAC-T sample in some circumstances. T or F
3. Standard Plate Counts or Heterotrophic Plate Count enumerate what?
4. If a positive BAC-T sample is received from the lab, what needs to happen next?
5. What causes the majority of positive BAC-T samples?
6. If a positive BAC-T is received, how many check samples must be taken and where must they be taken?
7. Chlorine should or should not be removed from disinfected water after flushing. T or F

***Answers to Review Questions for Chapter 10 – Bacteriological Monitoring***

1. 2
2. True
3. bacteria
4. notify DOW, notify customers, run check samples
5. sampler error or poor technique
6. 3
7. yes

This page left blank intentionally.

# Chapter 11: IRON AND MANGANESE

## Chapter 11 Objectives

1. Determine whether the detrimental effects of iron and manganese are health or aesthetically related.
2. Determine what methods are most frequently used to remove iron and manganese from the finished water.
3. Decide which method of iron and/or manganese removal is the most effective and the most cost effective.
4. Decide if precipitation is practical to remove iron and/or manganese from the water.

## ***Significance***

Iron (Fe) and manganese (Mn) are secondary contaminants that are not, at this time, considered health risks. These substances can be aesthetically objectionable primarily because the presence of these inorganic materials can change the appearance of water by turning it into a disgusting yellow –brown to black and even sometimes red substance. The precipitation of these materials onto plumbing and laundry fixtures can cause staining.

Another issue associated with iron and manganese is the growth of organisms such as crenothrix in distribution system piping. These microbial growths can reduce the carrying capacity of pipes, clog meters and valves, and produce taste and odor issues. Just as in any organism, these microbes expel waste and tend to smell when they die.



Iron and manganese occur naturally in clays ( there seems to be some of this in Kentucky), soils, and sediments from rocks and minerals of the earth's crust. They may also be linked to certain organic materials. In significant concentrations, iron and manganese in and off itself, can cause taste and odor issues. In their soluble or reduced state, iron and manganese appear colorless. When dissolved Fe and Mn are exposed to air or chemical oxidants they either precipitate or convert to their insoluble form. The chemical reaction that causes iron and manganese to precipitate when oxidized takes a particular amount of time reach completion which is pH dependent. The higher the pH, the faster the reaction. Higher temperatures can also increase the speed of the reaction. Under normal water treatment applications, we add chlorine, which is an oxidant, for disinfection which begins this chemical reaction.

At the end of the treatment process we sometimes raise the pH level for stabilization purposes, which serves to increase the speed of the reaction. Precipitation therefore will occur in the distribution system and the iron and manganese issues that were not resolved at the treatment facility will show up at the customers tap where it is the first place it is exposed to air.

Our goal as operators is to complete the chemical reaction as early as possible in the plant so that the precipitates will be formed and settle out later in the sedimentation basin or be filtered out.

## ***Treatment Techniques***

### **Oxidation**

The majority of iron and manganese removal plants use oxidation which, is accomplished by adding air or chemical oxidants, followed by detention, settling and filtration. The oxidation process chemically converts ferrous iron and soluble manganese to ferric iron and insoluble manganese. Air can be added through aeration, while chemical oxidation is usually accomplished using chlorine and/or potassium permanganate.



### **Aeration**

Aeration is accomplished by the introduction of air into the water. The oxidation reaction of aeration is accelerated by an increase in Ph, and decreased when lower temperatures prevail or with the presence of organic substances in the water. Lime, which removes carbon dioxide (CO<sub>2</sub>) from the water is sometimes used to raise the pH.

The aeration process requires careful control of the flow throughout the process. If the flow is too great, not enough time will be available for the reactions to occur.

Small changes in the raw water quality can alter the pH and the level of soluble organics and slow the reaction to the point that flows need to be reduced. Detention must follow the aeration process in order to allow time for the reaction to take place . The necessary minimum time is usually from 30 – 60 minutes dependent upon the pH and the temperature of the water. The oxidation of manganese by the use of aeration is so slow and requires such a high pH that is not practical for waters with a high manganese concentration.

### **Chlorine**

Chlorine , which is a strong oxidant, is added at a dosage of .64 mg/L per 1 ppm iron and 1.3 mg/L per 1 ppm manganese beyond the normal dosage used for disinfection. The higher the chlorine residual applied, the faster the reaction occurs. But again, if the raw water contains a high levels of organic color, more chlorine can mean more THM formation

### **Potassium Permanganate**

This is frequently fed early in the treatment process for oxidation needs that allows smaller doses of chlorine to be used for disinfection only thereby reducing THM formation. Potassium permanganate is an effective oxidant that will precipitate iron and manganese without THM formation. Accurate feed rates are required and enough must be fed to ensure that oxidation ensues but not enough to cause the bright pink carryover through the filters. Permanganate dosages are 0.9mg/L per part of iron and 1.92 mg/L per part of manganese. Potassium can also be used in conjunction with greensand filtration to effectively remove manganese although it is usually only viable for small flow systems.





***Review Questions for Chapter 11 – Iron and Manganese***

1. Fe and Mn are primary or secondary contaminants? Identify the difference between primary and secondary contaminants.
2. List the four most frequently used ways to remove Fe and Mn.
3. From a treatment perspective, what is the greatest impact algae has?
4. What is the most effective way to deal with taste and odor issues?

***Answers to Review Questions for Chapter 11 – Iron and Manganese***

1. secondary contaminants; primary equals health and secondary equals aesthetics
2. oxidation, aeration, chlorine oxidation, potassium permanganate oxidation
3. algae changes both the pH and the dissolved oxygen content
4. prevent them from occurring

# Chapter 12: TASTE and ODOR CONTROL

## Chapter 12 Objectives

1. Define oxidation.
2. Define aeration.
3. Determine which treatment technique effectively removes gases, especially benzene, from water.
4. Determine what substance is extremely effective in removing organics and particulates from the water because of its extremely large surface area.
5. Determine the best approach to taste and odor issues not presenting a problem.
6. List some origins of taste and odor issues in municipal water treatment.
7. Determine what two elements combine to impart hardness to the water.
8. Determine the chemistry that occurs that causes hardness to permeate the water.
9. List the issues that hardness causes.
10. List the methods used to remove hardness from water, which one is best, which one is cheapest, which one isn't practical for large daily volumes of water.
11. Define ion exchange and what does it exchange

### ***Taste and Odor***

The average customer judges his or her water quality by their senses of sight, smell or taste. But issues pertinent to taste and odor are usually one of the largest number of complaints a system receives. This in turn causes customer frustration, operator frustration with the time expended and with having to correct the problem rather than dealing with the causes(s) of the problem. The answer to successful taste and odor control is to prevent them from ever occurring in the first place. This could mean controlling algae in the raw water, anticipation of seasonal water turnover, and the inclusion of preventative maintenance to address other taste and odor issues that are not predictable but still frequently occur. Taste and odor problems can be the result of natural or man-made conditions that can exist anywhere within the water supply system:

raw water sources

intakes

treatment plants themselves

storage facilities

distribution system shortcomings

municipal wastewaters

industrial spills

chemical spills

urban runoff

agricultural wastes

consumer plumbing

biological growths

Biological growths means metabolic byproduct formation. As microbial entities grow and reproduce, they produce metabolic byproducts that are released into the water which can cause unpleasant tastes and smells. As these microorganisms grow, organic material accumulates in the cell.

When they die the cells rupture and release this cellular material into the water. Natural die-off of the predominating organism that follows an algal bloom results in the release of cellular materials that can cause a problem and the microorganisms feeding on the dying algae will produce even more obnoxious smelling metabolic byproducts.

Algae blooms are caused by:

Increased nutrient levels

Readily available sunlight

Favorable water temperatures

The inflow of many pollutants, particularly decomposing organic material and compounds containing nitrogen and phosphorus, increase the nutrient levels in raw waters. Microbial populations are generally low in unpolluted waters and the oxygen transfer from the atmosphere is sufficient to prevent oxygen conditions from developing. However, when available nutrient concentrations increase, rapid microbial growth occurs that consumes dissolved oxygen (DO) at a rate faster than it can be replenished. Oxygen depleted conditions lead to the death of aquatic plants and animals which creates taste and odor problems.

Algae undergoes photosynthesis during the daylight hours which promotes oxygen to be produced and released into the water faster than it can escape into the atmosphere which creates a condition know as supersaturation. At night photosynthesis stops and respiration begins. Respiration is the process that consumes oxygen and releases carbon dioxide just as humans do. Oxygen depletion during the night could result in fish kills and the demise of other aquatic plants and animals. Oxygen depleted conditions could also allow anaerobic organisms to take hold and contribute to water quality degradation. The most pressing issue to operators is the fact that water quality conditions can differ substantially from night to day. When algae give off oxygen, carbon dioxide is removed from the water resulting in an increase of the pH during daylight hours. At night during the respiration stage, carbon dioxide (CO<sub>2</sub>) levels will increase and the pH level will decrease. These changes in pH can influence dosage levels required to viably treat the water.

Recirculated wastewater from filter backwash discharges and decanted sludge disposal can increase nutrient levels in the plant that can cause similar problems.



Nutrients, organic material etc. settle on the bottom of rivers and reservoirs. These deposits build up over time and when flow increases due to heavy precipitation events or seasonal turnover due to temperature changes, the sediments will resuspend and they will most likely carry over into the plant. These sediments can carry septic, musty, or earthy odors in with the raw water.

### ***Treatment of Tastes and Odors***

Viable methods for eliminating tastes and odors include:

**Oxidation** – chlorine, potassium permanganate, chlorine dioxide, ozone, etc.

Aeration

**Adsorption** – activated carbon

**Optimization of the Treatment Processes** – coagulation, flocculation, sedimentation, filtration, stabilization

### ***Water Softening***

Water contains various amounts of dissolved entities, some of which are dissolved minerals. Some of these minerals, calcium and magnesium in particular, cause hardness. The extent of water hardness varies from state to state due to the different geological makeup of the area and the amount of time that the water has been in contact with these minerals. Two of these minerals are of interest in relation to hardness:

**Calcium** is dissolved into the water as it passes over or through limestone, of which there is a good bit in our state.

**Magnesium** is dissolved into the water as it passes over dolomite or other magnesium bearing materials.

Because groundwater is in contact with these minerals for much longer than is surface water, **groundwater usually contains a higher degree of hardness than surface water.**

### ***Problems Associated with Hard Water***

Hard water forms scale ( $\text{CaCO}_3$ ) which causes a variety of problems. White scale deposition on plumbing fixtures, tubs, sinks, cooking utensils, water heater heating elements etc.

Scale formation on the interior of pipes that can substantially reduce carrying capacity.

Excessively hard water can cause premature wear of appliances, water meters, pressure reducing valves, etc.

Scale reduces the efficiency of water heaters and boilers

Hard water reduces the lathering of soaps

### ***Problems Associated with Soft Water***

Consumers prefer soft water over hard but extremely soft water can also cause problems.

Soft water accelerates the rate of corrosion which shortens the useful life span of any metallic structure, such as appliances and distribution systems.

Corrosive water can result in the leaching of toxic substances such as lead and cadmium being deposited into the drinking water.

Ion exchange effectively softens water but imparts sodium to the water which could be an issue to some consumers.

### ***Water Hardness Chemistry***

Hard water is caused by soluble, divalent, metallic positively charged ions that are attracted to the cathode. The two main cations that cause water hardness are calcium, (Ca) and magnesium (Mg). Although strontium, aluminum, barium, ion, manganese, and zinc also cause hardness in water, they are not usually present in large enough concentrations to contribute significantly to total hardness. Water hardness is expressed as a concentration of calcium carbonate (mg/L CaCO<sub>3</sub>).

Hardness is categorized by either of **two methods**:

Calcium and magnesium hardness

Carbonate and noncarbonated

Calcium and magnesium hardness is identified by the minerals involved.

Calcium derived hardness is obviously called calcium hardness.

Hardness that is caused by magnesium, who would have thought, magnesium hardness!

TOTAL HARDNESS = Calcium Hardness + Magnesium Hardness

Carbonate and noncarbonated hardness are identified both by the bicarbonate salts of calcium and by the normal salts of calcium and magnesium involved in causing the hardness of the water.

Carbonate hardness is primarily caused by the bicarbonate salts of calcium and magnesium.

Noncarbonate hardness is a measure of calcium and magnesium salts other than carbonate and bicarbonate salts, such as calcium sulfate, calcium chloride, magnesium sulfate, and magnesium chloride.

So, in this instance Total Hardness = Carbonate Hardness + Noncarbonate Hardness.

When water is boiled, carbon dioxide is driven off, the bicarbonate salts of calcium and magnesium will then precipitate or settle out to form calcium and magnesium carbonate precipitates. These hardness causing precipitates form the familiar white chalky deposits known as scale.



## ***Softening Methods***

The two most commonly used methods to remove hardness in the water business are:

lime – soda ash

ion exchange

### **Lime - Soda Ash Method**

This method is used most frequently in larger treatment facilities.

Lime and soda ash are added to the water.

This action removes carbonate and noncarbonate hardness

This forms insoluble precipitates such as calcium carbonate and magnesium hydroxide.

We then can remove the hardness by conventional sedimentation and filtration. Caustic soda (sodium hydroxide) can be substituted for soda ash. If caustic is used it removes carbonate and noncarbonate hardness

### **Advantages**

Produces less sludge

The chemical is easier to handle

There are some **disadvantages**:

This method is more expensive

This increases the amount of total dissolved solids. Because of these disadvantages, caustic is not used as much as lime and soda ash.

### **Ion Exchange**

This process removes hardness by exchanging them with sodium ions.

Ion exchange media such as polystyrene resins are placed in a unit

Unsoftened water is passed through these resins

The calcium and magnesium ions attach themselves to these resins

Sodium ions are exchanged for the calcium and magnesium ions and the sodium is imparted to the water.

When the resins are saturated with the calcium and magnesium, a brine solution is passed through the unit to regenerate the resins.

This is basically the same process used in home softening units. These systems can be practical in small flow systems with groundwater as their source water. When the majority of the hardness is in noncarbonate form, this method can actually be less expensive than the lime and soda ash process. This process to date is not easily adapted to surface water sources.

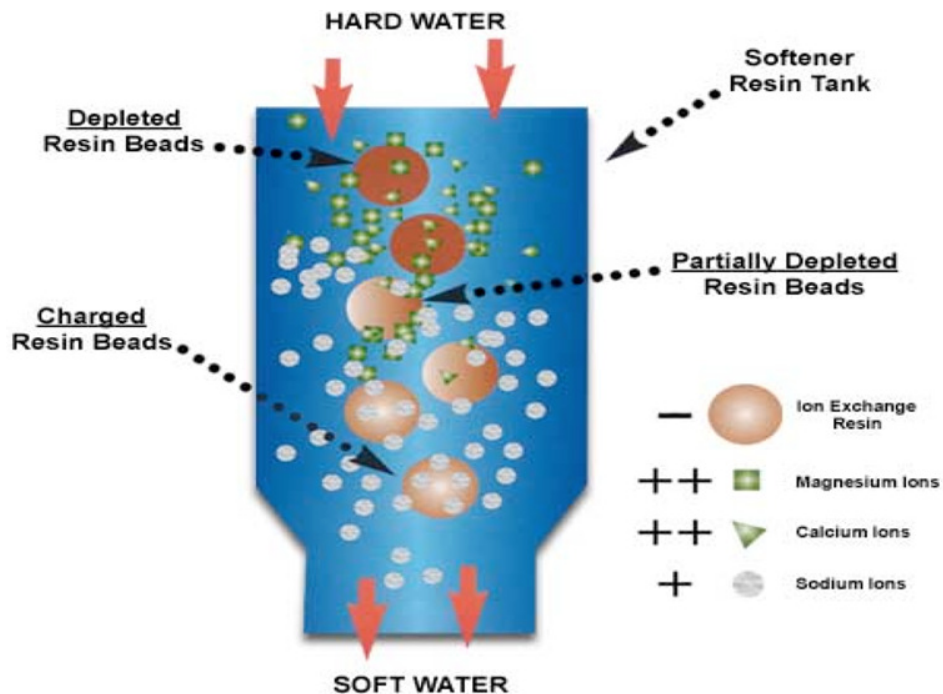

### ***Alternative Processes***

There are other methods that can be used to soften water but none of them is used frequently in municipal water treatment because of their complexity and costs.

Electrodialysis

Distillation

Freezing

Reverse Osmosis

***Review Questions for Chapter 12 – Taste and Odor Control***

1. What substance causes scale to form on plumbing fixtures and water heater heating elements?
2. What are the two most frequently used treatment approaches to remove hardness?
3. Explain the process of an ion exchange softening unit.

***Answers to Review Questions for Chapter 12 - Taste and Odor Control***

1. calcium carbonate
2. lime-soda ash, and ion exchange
3. sodium ions are exchanged for hardness ions

# Chapter 13: FLUORIDATION

## *Chapter 13 Objectives*

1. List the chemicals commonly used for fluoridation of drinking water.
2. Determine the reason given for the need to fluoridate water.
3. List the potential health effects of overdosing fluoridation chemicals in the drinking water.

## Flouridation

Fluoride is added to the drinking water to improve the development of teeth and bones in young children. At low levels fluoride can be a beneficial additive to drinking water. But, just as in many of life's circumstances, excessive fluoride has negative effects. Fluoride levels in excess of the secondary MCL of 2 mg/L can cause discoloration of the teeth. Fluoride in excess of the primary MCL or 4 mg/L can cause bones to become brittle.

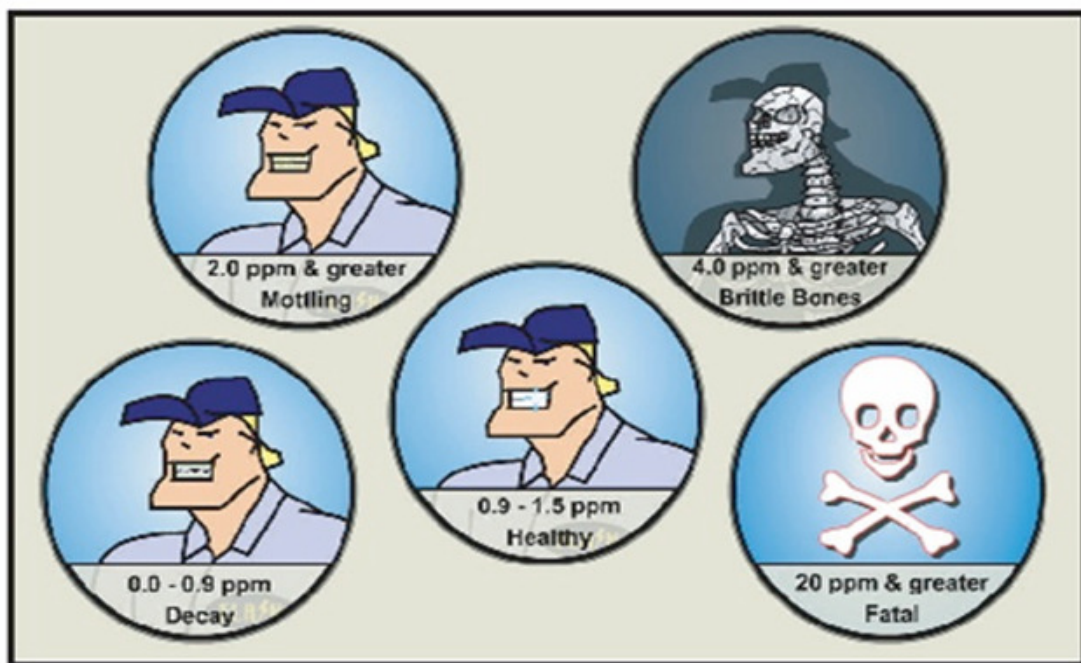

2.4 Figure 1: Fluoridation results

Systems that add fluoride to their drinking water generally use one of the three chemicals:

Sodium Fluoride

Hydrofluosilicic Acid

Sodium Silicofluoride

Frequent monitoring of these substances is necessary to ensure that the proper levels of fluoride are being delivered to the consumer. In rare instances, it could be necessary to lower the fluoride level of source waters by blending it with low fluoride level waters or use

some means, like ion exchange, to remove the fluoride. Regular monitoring of fluoride will also help to prevent accidental overdosing of fluoride. Feeders and scales should be calibrated frequently, again just to ensure the correct dose is being fed.

The presence of some substances in water can interfere with the analytical tests for fluoride. These substances include:

Aluminum, commonly used as coagulants will give erroneously low readings

Phosphate which is commonly, at least for now, used as a corrosion inhibitor will give erroneously high readings.

Water systems using these chemicals should review testing procedures with your laboratory staff. Additional sample preparation might be necessary to neutralize the effect of these substances. Additional information relative to these issues can be found in Standard Methods.

In Kentucky, the fluoridation of public drinking is administered by the Health Services Cabinet. The program coordinator is:

Don Miniard  
Cumberland District Health Department  
606-558-3150

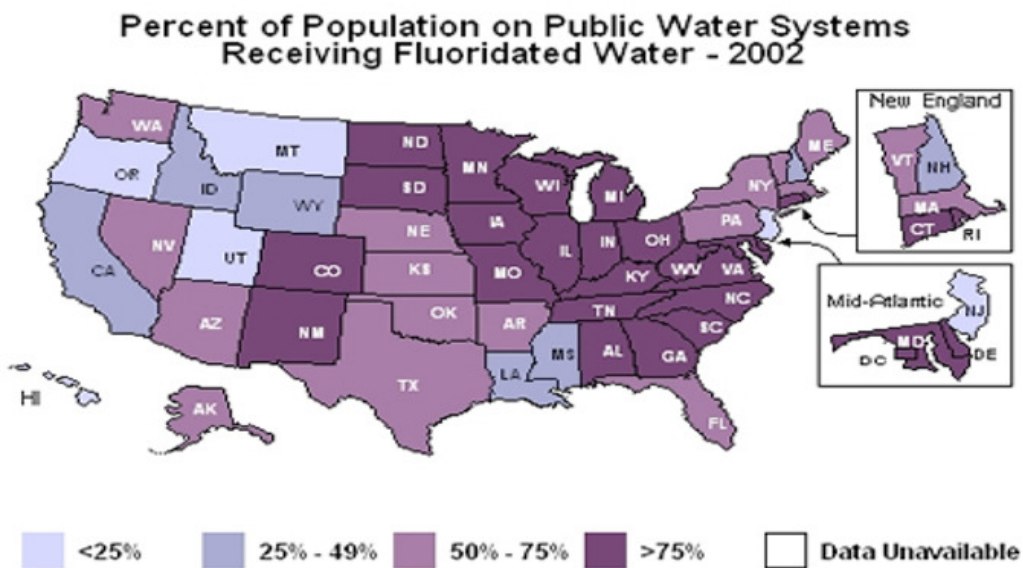

Source: Water Fluoridation Reporting System 2002

***Review Questions for Chapter 13 - Fluoridation***

1. Identify the department which regulates the fluoridation of water in Kentucky.
2. What commonly used coagulant can precipitate false fluoride readings?



***Answers to Review Questions for Chapter 13 – Fluoridation***

1. The Department of Health
2. Aluminum

This page left blank intentionally.

# Chapter 14: STABILIZATION

## *Chapter 14 Objectives*

1. Determine what methods are viable to stabilize the water.
2. Define corrosion, galvanic corrosion and how it relates to the galvanic series.
3. List the detrimental effects of corrosion as it relates to health, economics, and aesthetics.
4. Determine the tangible effects of scale formation.
5. Determine whether or not temperature and/or dissolved oxygen have an impact on the rate of corrosion.
6. Determine what water quality changes and chemical additives can be used to retard corrosion
7. Determine what the Langeliers Saturation Index is, how it is relevant and how it is used.
8. Determine how coupons can be used to determine the propensity of the water to be corrosive or scale forming.

## ***Stabilization***

Stabilization of our drinking water is necessary to prevent the effects of corrosion or excessive scaling in the distribution system.

### **Potential Problems Associated with Scale and Corrosion**

- **Public Health**

The leaching of metals such as lead, copper, cadmium, arsenic, and zinc, among others, can cause serious health concerns and potentially death. A water system in the United States was found to have lead levels 40,000 times higher than the regulatory levels.

Corrosion and scaling can shield pathogens from disinfection since they can encapsulate or come between the disinfectant and the pathogen.

Backflow from pressure loss caused by leaks that was brought about by allowing corrosion to destroy pipes and other devices.

- **Economic Issues**

Corrosion and scaling can cause reduced pressure and carrying capacity in the distribution system due to increased friction on pipe walls and reducing the inside diameter of pipes.

It takes longer to pump a particular volume through a smaller pipe as opposed to a larger one so energy costs are accelerated.

More frequent leaks and the capital costs associated with them such as overtime pay, replacement costs.

The increased energy requirements for boilers and hot water heating devices frequently occur.

The costs associated with regulatory compliance.

### ***Aesthetics, Water Quality, Consumer Confidence***

Corrosion frequently causes an increase in color, taste, odor, turbidity, microbial growth, and the staining of plumbing fixtures.

When consumers open their tap and the substance that flows from it looks disgusting, smells putrid, and tastes horrible, the loss of confidence in that water system is not something that is easily reversed

## ***Factors Affecting Corrosion***

### pH

Lower pH levels increases corrosion rates; higher pH levels promotes the precipitation of calcium carbonate or scale, which can offer protection against corrosion.

### Alkalinity

Scale in the carbonate and bicarbonate forms will deposit a protective coating to the interior of pipes that reduces corrosion rates. Hydroxide will form that will not precipitate scale and also buffer pH changes.

### Hardness

Calcium hardness could precipitate as calcium carbonate, or scale, to reduce the corrosion rate.

Excessively soft water is very corrosive.

### Dissolved Oxygen (DO)

High levels of dissolved oxygen can accelerate the corrosion process.

### Total Dissolved Solids (TDS)

A high level of total dissolved solids increases the conductivity of the water and therefore, the rate of corrosion.

### Temperature

Just as with any chemical reaction, warmer means quicker. Since corrosion is an electrochemical process, warmer temperatures means increased corrosion rates.

### Chlorine residual

When chlorine comes into contact with moisture, corrosion ensues.

### Biological activity

Depending on the type of organism, corrosion can either speed up or slow down their activity rate.

Chemical substances

Hydrogen sulfide, chloride and sulfates present in the water can increase corrosion.

Electrical current

If a cold water line is being used as an electrical ground, the rate of corrosion is being greatly accelerated.

Galvanic Corrosion

The further apart any two metals are on the galvanic series affects the cathodic and anodic rate which impacts the rate of corrosion

Galvanic Series is shown below:

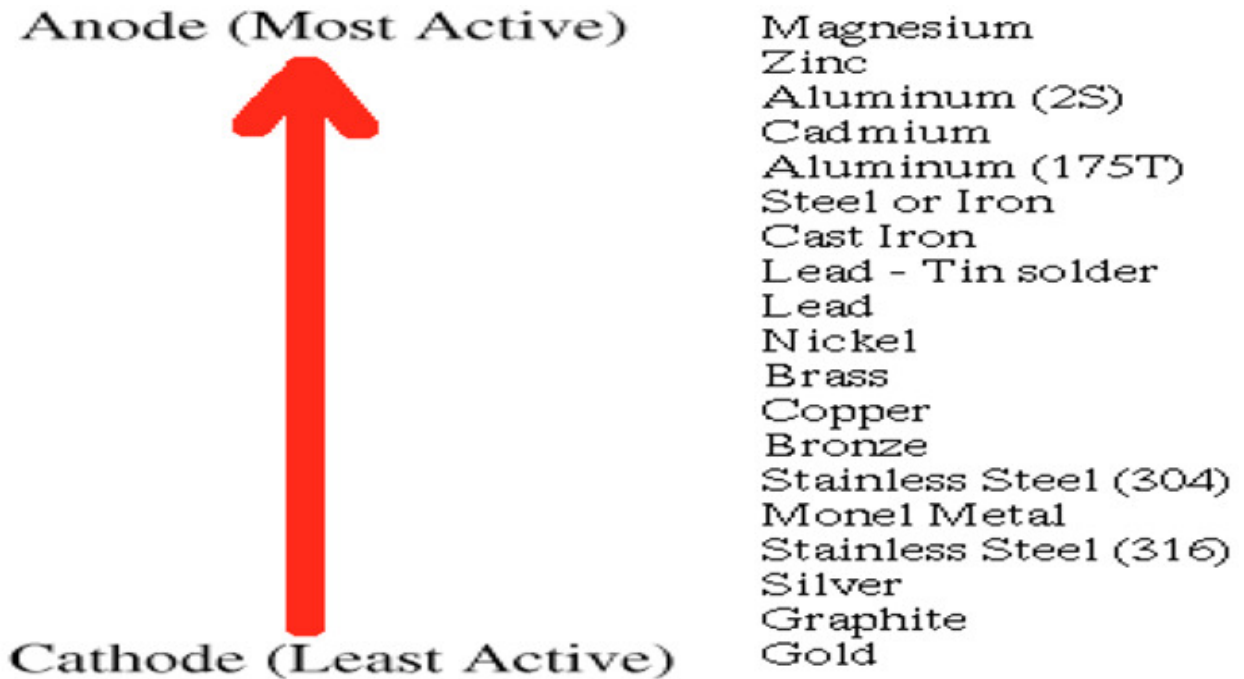

### ***Basic Approaches to Corrosion Control***

Modify the water quality by adjusting the pH so that it is less corrosive to the pipe and tank materials.

Impart a protective barrier between the water and the metallic material by injecting phosphates into the finished water.

Use system materials and design the system to minimize the chances of corrosion from impacting the system.

Use corrosion resistant linings, coatings and paints.

Provide cathodic protection to corrosion prone structures.

### ***Monitoring***

There are a number of ways to monitor the rate of corrosion. The key is to not take the “out of sight, out of mind” approach and get caught by large areas of your distribution system failing, or even worse, failing at the same time.

Consumer complaint records evaluation

Ryznars Index

Coupon testing

Distribution material inspection

Residual testing

Aggressive Index

Langeliers Saturation Index

### ***Langeliers Saturation Index (LSI)***

The LSI is a chart which takes into account the calcium hardness level, the alkalinity, the temperature of your water along with the measured pH or, the pHA of your water. When you chart these variables out you will obtain another pH, the pHS or saturation pH. When both pH numbers have been obtained, the pHS is subtracted from the pHA. If the sum is a positive number, your water has the likelihood or propensity to be scale forming.

If the sum is a negative number, your water has the likelihood to be corrosive.

pHA 6.8

pHS 7.3

-0.5 This water has the likelihood of being corrosive.

An example of the Langeliers Satuartion Index

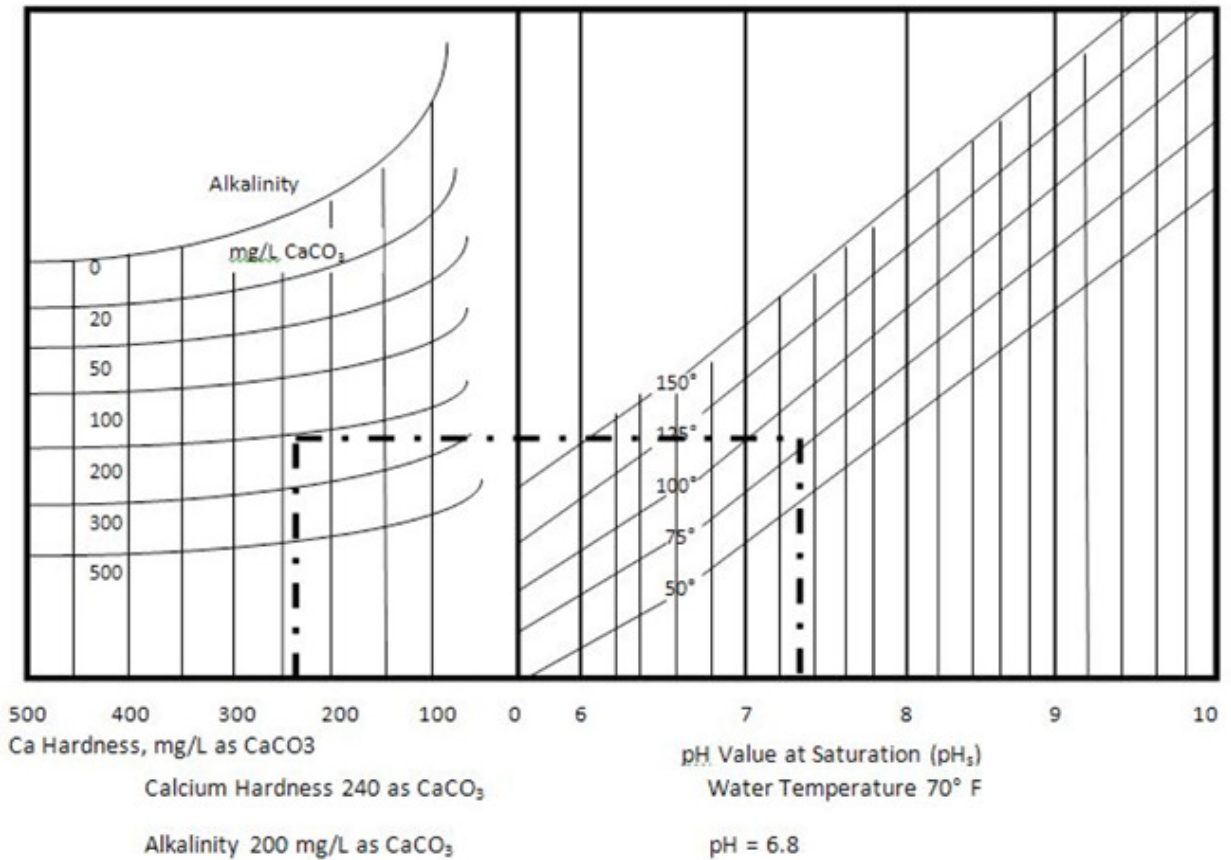



***Review Questions for Chapter 14 - Stabilization***

1. Describe the human health impacts associated with corrosion.
2. Describe the system impact of corrosion (i.e. pumping rates, leak rates, overtime costs).
3. If pHA is 7.4 and pHS is 7.2, is the water corrosive or scale forming?
4. What are the pieces of pipe removed to make a tap into an existing water line called?
5. The \_\_\_\_\_ \_\_\_\_\_ Index is used to determine the corrosive or scale forming properties of water.
6. Explain the relationship between velocity and pressure.
7. Identify ways to minimize corrosion.
8. Explain what causes corrosion to increase.
9. Describe the galvanic series.

***Answers to Review Questions for Chapter 14 – Stabilization***

1. permeation, leaching
2. yes . Corrosion restricts the interior diameter of the pipe, reducing the volume or carrying capacity and increasing pumping costs.
3. scale forming
4. coupon
5. Langeliers Saturation Index
6. inverse
7. water quality modification (pH adjustment), protective barrier (phosphates), use non-corrosive materials, use lined pipe (cement lined DI), cathodic protection, monitor with the LSI, Ryzners etc.
8. chlorine residual, biological activity, chemical substances, electrical current, dissimilar metals
9. dissimilar metals

# Chapter 15: CROSS CONNECTIONS

## *Chapter 15 Objectives*

1. Define a cross connection, backflow, backsiphonage, and backpressure.
2. Determine what is responsible for more waterborne illnesses than any other factor and whose responsibility it is if it occurs.
3. Determine how a cross connection program should be implemented and what should a program contain.
4. Determine the three levels of hazards of backflow.
5. Decide which form of backflow protection is the most foolproof, the most effective.
6. Decide which backflow prevention devices work only against backsiphonage.
7. Decide which backflow devices work against backpressure and backsiphonage.
8. Decide which backflow device(s) are approved for toxic substances.
9. Determine how frequently backflow prevention devices should be tested.
10. List some instances when backflow could occur.
11. Determine what device is frequently needed when a backflow prevention device is installed to counteract the effects of expansion due to the heating of water.
12. Delineate the two types of cross connection prevention programs.

***Cross-Connection Control***

Backflow, which is accomplished through a cross connection has been shown to be responsible for more waterborne illnesses than any other factor.

**WHY PAY SO MUCH ATTENTION TO CROSS CONNECTIONS?**

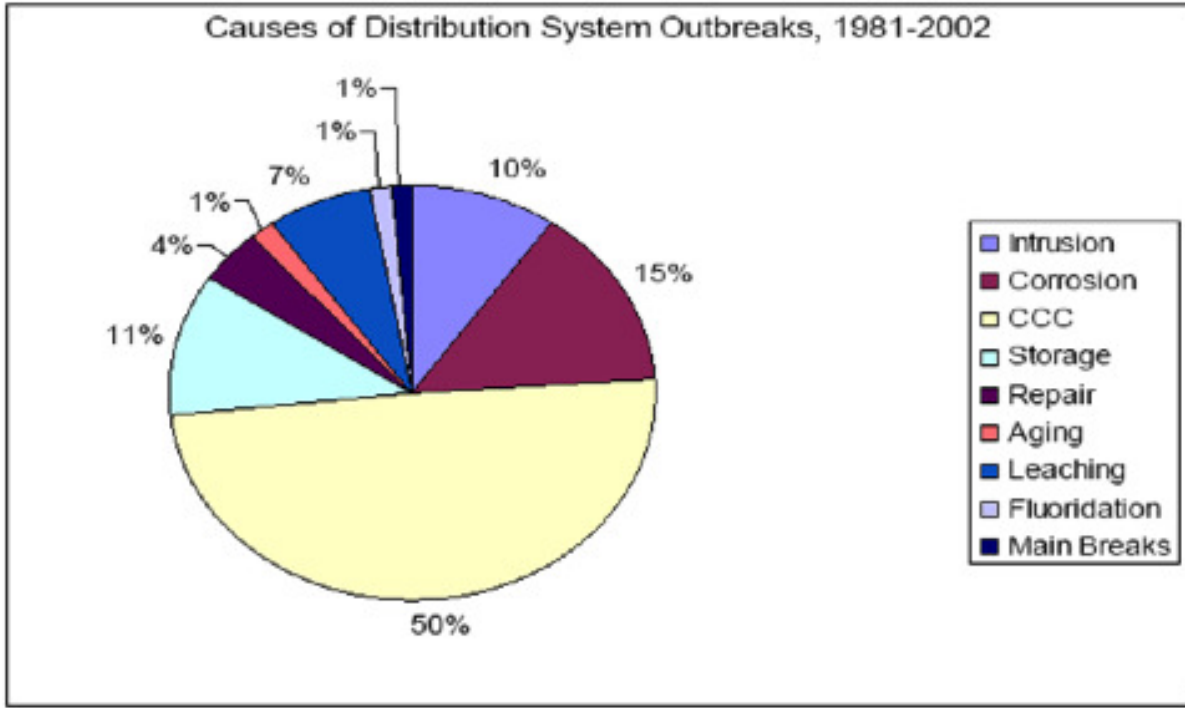

As the above chart illustrates, more people have gotten sick because of backflow than all of the other factors combined. But still no federal regulations mandating backflow prevention at the municipal level. Plumbing codes now demand them but municipal water systems are not regulated to have a backflow prevention program in place. Why? In my opinion it starts with the issue of funding. These devices are not cheap and someone will have to pay for them.

Backflow, by definition, is a reverse flow condition whereby a nonpotable substance enters into the potable drinking water system, potentially exposing the water supply, and

everyone who consumes their water, to chemical or biological contaminants or pollutants.

The health hazards and the associated potential liability should make backflow prevention important to every water supplier, if not for financial reasons, then moral ones.

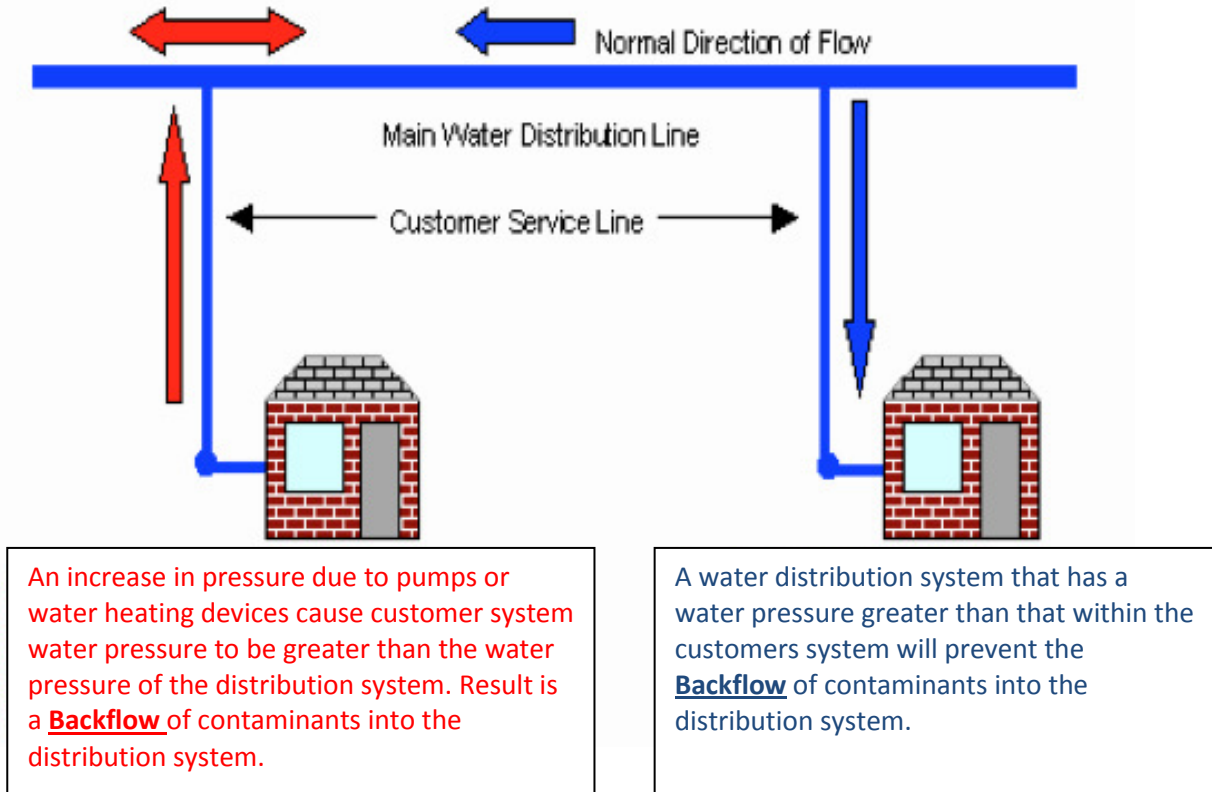

“ENTIRE FOOTBALL TEAM CONTRACTS HEPATITUS FROM BACKFLOW INCIDENT”

“CHILDREN AND STAFF AT VBS SICKENED BY CHLORDANE FROM BACKFLOW INCIDENT”

“UPON INVESTIGATING COMPLAINTS FROM WATER CUSTOMERS, PESTICIDES FOUND FLOWING IN DRINKING WATER MAINS”

“NINE PEOPLE UNDERGOING KIDNEY DIALYSIS KILLED WHEN BACKFLOW INCIDENT OCCURS SIPHONING ETHELYNE GLYCOL INTO BUILDING’S WATER SUPPLY”

“MAN DRINKS BLOOD FROM FUNERAL HOME DRINKING FOUNTAIN”

At a funeral home in Georgia, people were paying their respects to the dearly departed. Simultaneously, the funeral director was embalming another body in preparation for viewing. A drop in system pressure resulted in bodily fluids being sucked back into the drinking water supply. This was discovered when a visitor to the funeral home found himself swallowing a large dose of blood and bodily fluids.

This incident and the headlines are not fabricated. They are taken directly from the EPA cross connection book. Before this issues are dismissed think about where the funeral homes in you area are located. I would guess at least some of them are in the larger, older, homes that were built long before plumbing codes mandated backflow prevention devices be installed where needed. What would the reaction in your area be if an incident like this occurred there?

The City of Georgetown had a backflow incident at a greenhouse where someone was affected by the substance that backflowed from the greenhouse. When the Division of Water appeared in Georgetown their first question to Billy Jenkins, who at the time was in charge of the distribution system, was “Mr. Jenkins, do you have a written implemented cross connection program in place?” His reply was “no”. The Division of Water representative then told Mr. Jenkins that the fine would be \$25,000 a day until one was implemented. Could YOUR system afford that?

A backflow occurs because of a cross connection. A cross connection is any physical link between a potable water supply and one of unknown or questionable quality.

There are two conditions necessary for backflow to occur:

- Backpressure is where the nonpotable system pressure increases to where it is greater than the potable side that reverses the flow, OR
- Backsiphonage is where the potable system drops to a pressure lower than the nonpotable water system.

### ***Cross Connection Control Programs***

There are two types of programs.

**Isolation** – protecting the consumer at the supply end.

**Containment** – protecting the water system at the service connection.

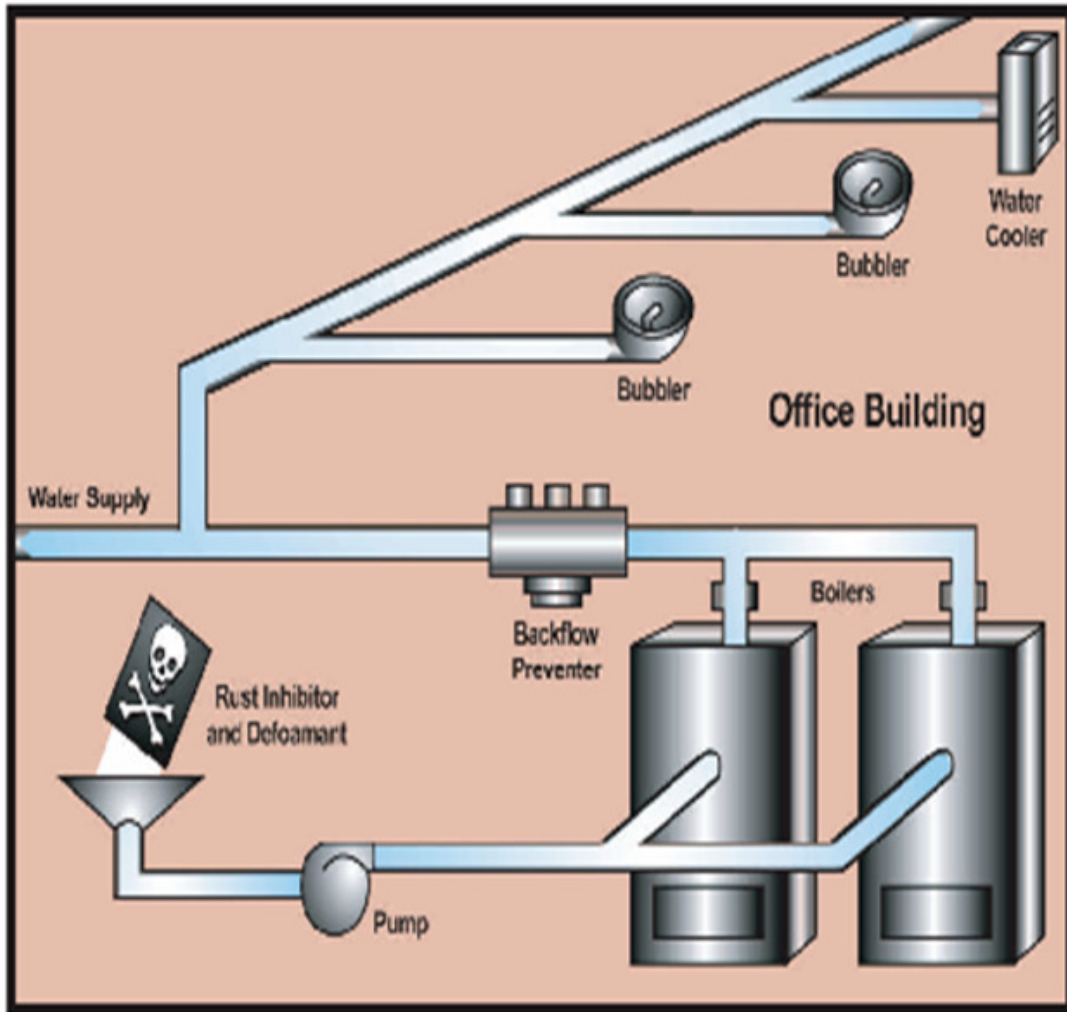

8.3 Figure 2: Isolation protects individual sites

**Containment:** Protecting the water system at the SERVICE CONNECTION.

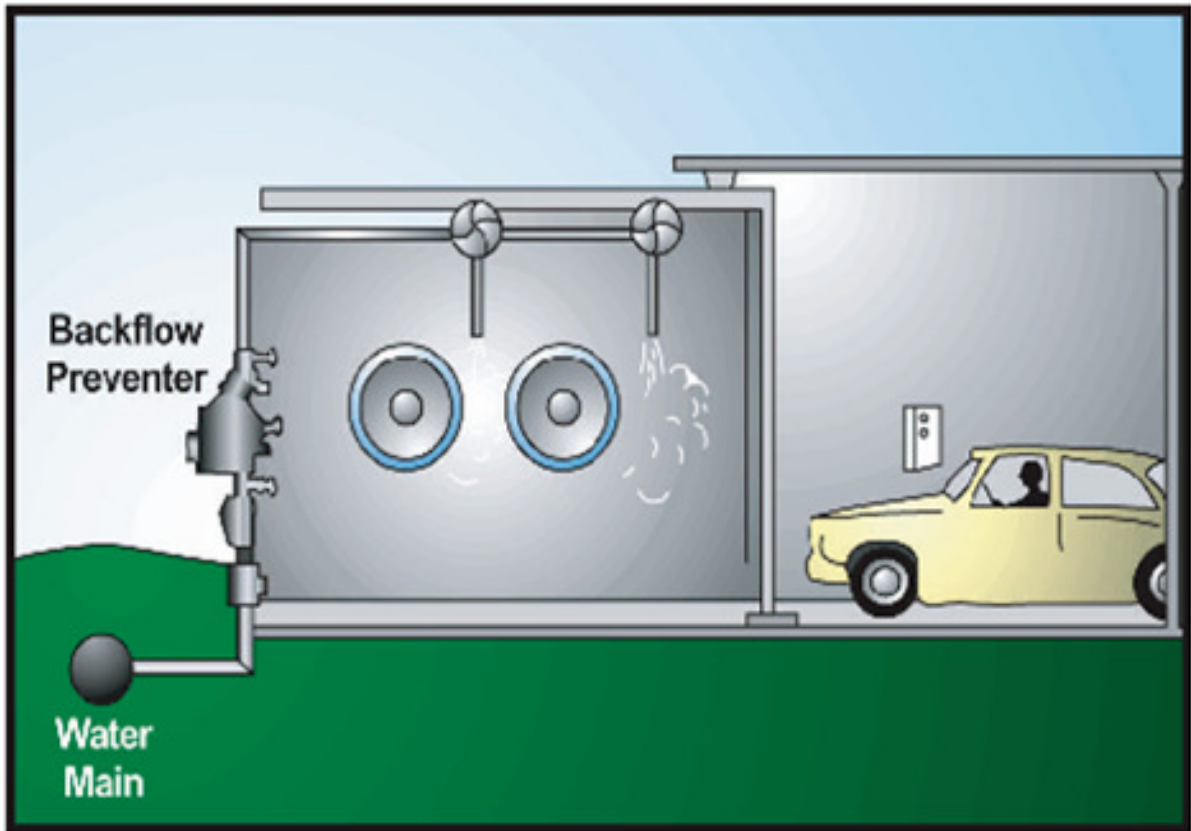

8.3 Figure 1: Containment protects the public water system

Before embarking on a cross connection control crusade there are some considerations to be made. Voluntary compliance seldom works so some means to compel customers to install backflow prevention devices is needed.

Your success could be dependent upon:

Local ordinances – defines the roles, responsibilities, penalties legalities, etc. Without this you have no program.

Surveys – locate cross connections, asses the potential hazards, assign the appropriate devices

Certification – Train and certify the installers, testers, repairers, and certify the viability of the device at least annually.



Education – Educate everyone; the local officials for funding and support, the staff and installation contractors for implementation and your consumers for understanding, acceptance and support.

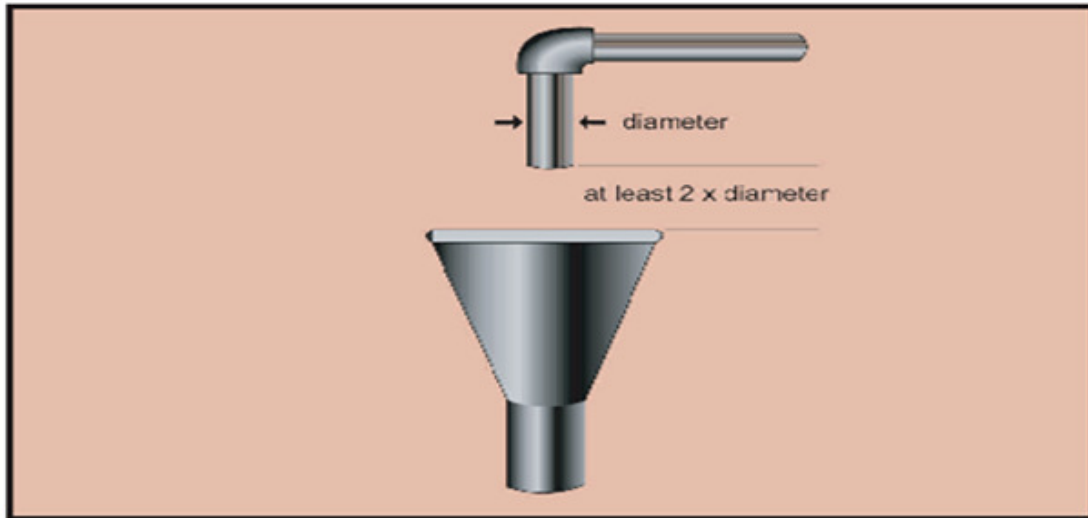

8.4.1 Figure 1: Air gap

### ***Backflow Prevention Devices***

The most foolproof backflow prevention device is the air gap.

#### **Air Gap**

An air gap is a physical separation from where the water leaves the pipe to where it is to end up.

An air gap must

be 2 times the inside diameter of the pipe or 1 inch, whichever is greater.

The only viable device for high toxic applications.

It is the easiest to maintain but also the easiest to defeat.

#### **Reduced Pressure Zone Backflow Preventer (RP, RPZ)**

It is recommended that these devices should be installed above ground at a height of 12 inches minimum and 30 maximum.

Can also be used for toxic substances but this device is not as reliable as an air gap.

If the potentially contaminated water backflows and the water makes its way past the first valve, this device will send the contaminated water to the atmosphere by the use of a differential relief valve before the water gets to the first check valve.

The relief valve should not be plugged, buried, or submerged.

Prevents backpressure and backsiphonage

## RP WITH A FOULED CHECK VALVE

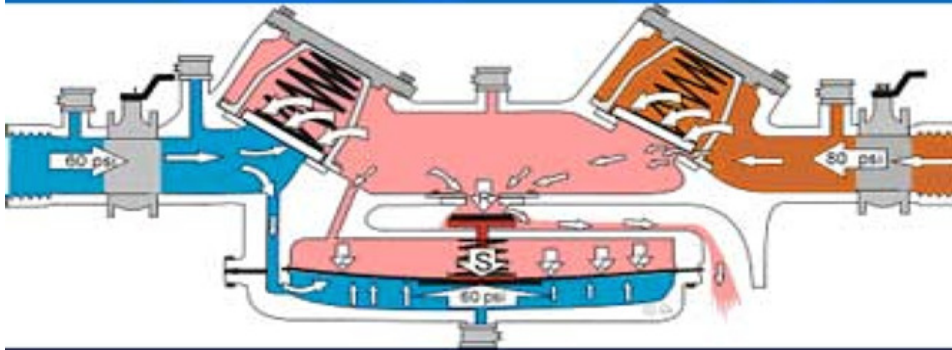

## RP IN NORMAL CONDITIONS

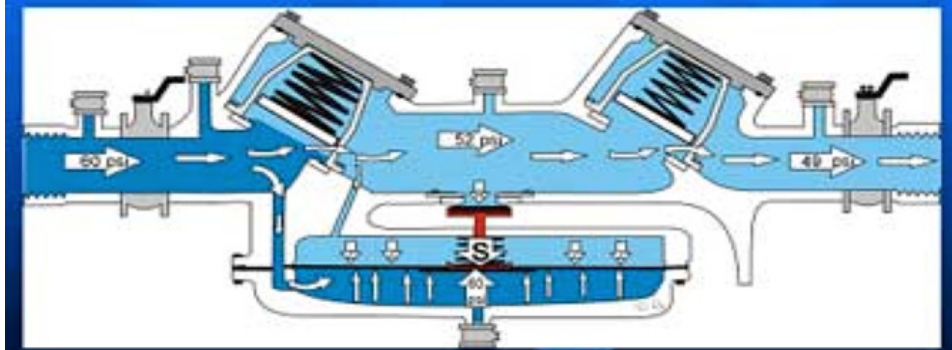

One issue that develops with the installation of a backflow prevention device is that a closed system now exists. When water is heated it expands. Before the installation of the backflow prevention device, heated water could backflow through the premise plumbing, through the meter and out the service line to the main. We have now blocked the waters exit from the building. Because of this it is necessary to install a thermal expansion device.

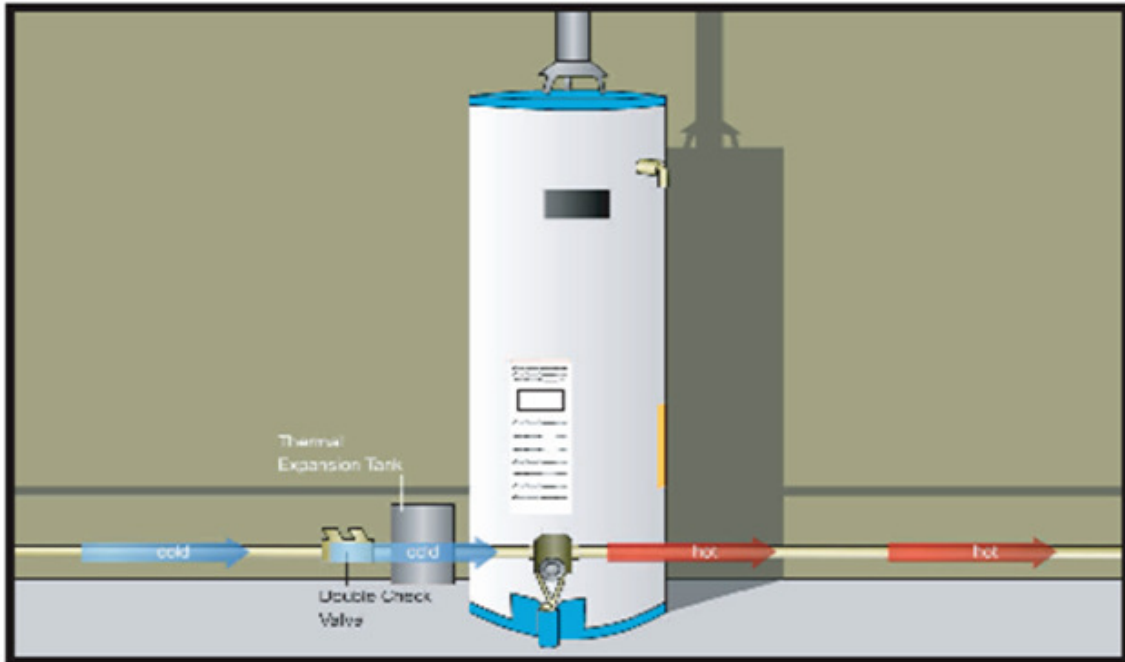

8.5 Figure 1: Allow for thermal expansion



### ***Double Check Valve***

Installed above ground

Used for low hazard applications

Prevents backpressure and backsiphonage

Most commonly used as a residential backflow prevention device

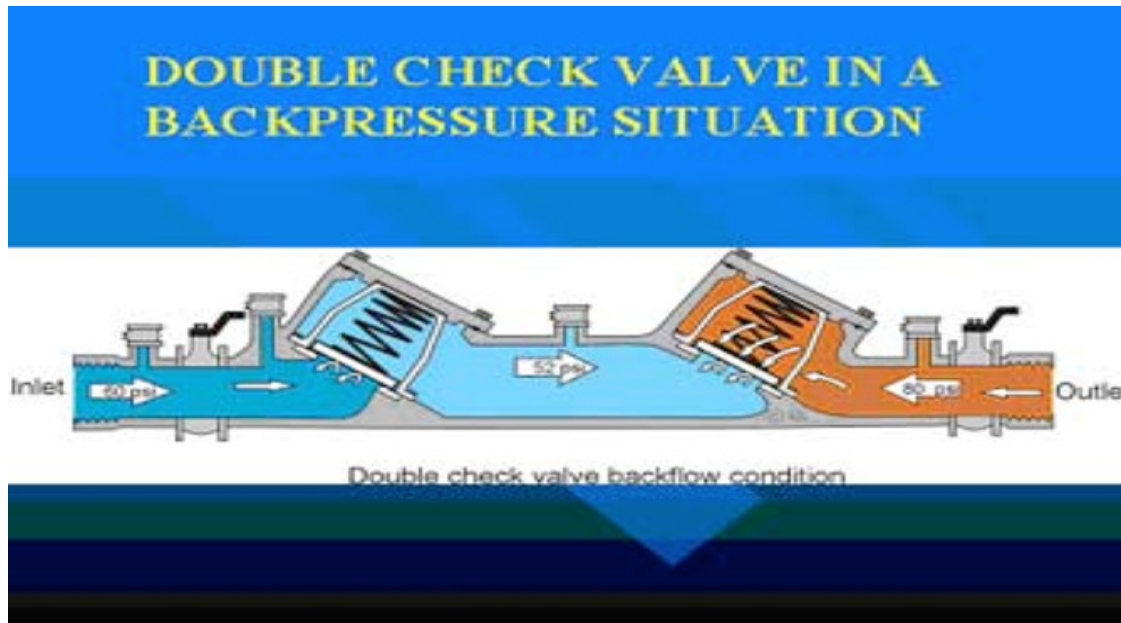
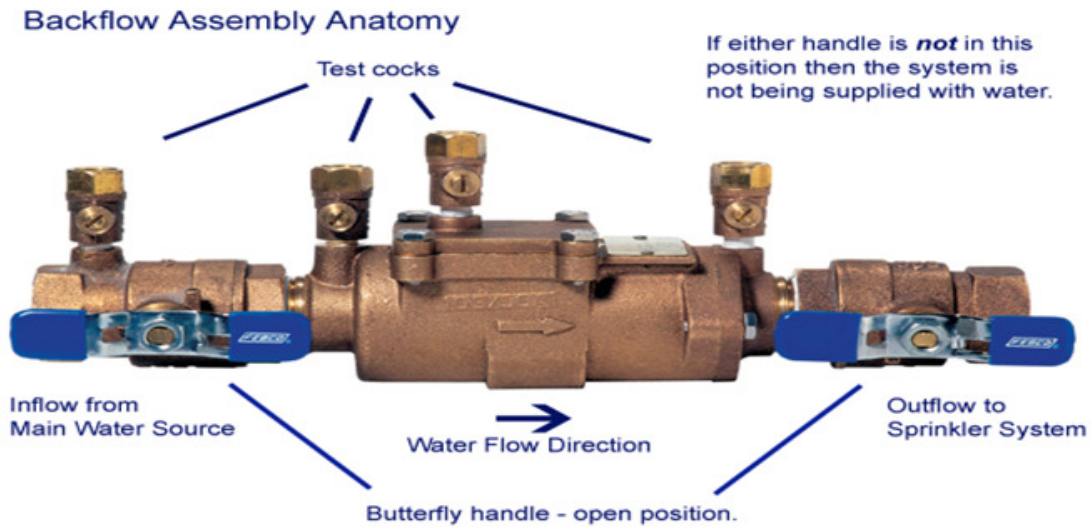

***PRESSURE VACUUM BREAKER (PVB)***

Should be installed 12 inches above the highest downstream outlet

May have a control valve downstream and can operate under continuous pressure

Can be used for high hazard contaminant or low pressure pollutant

Protects against backsiphonage only

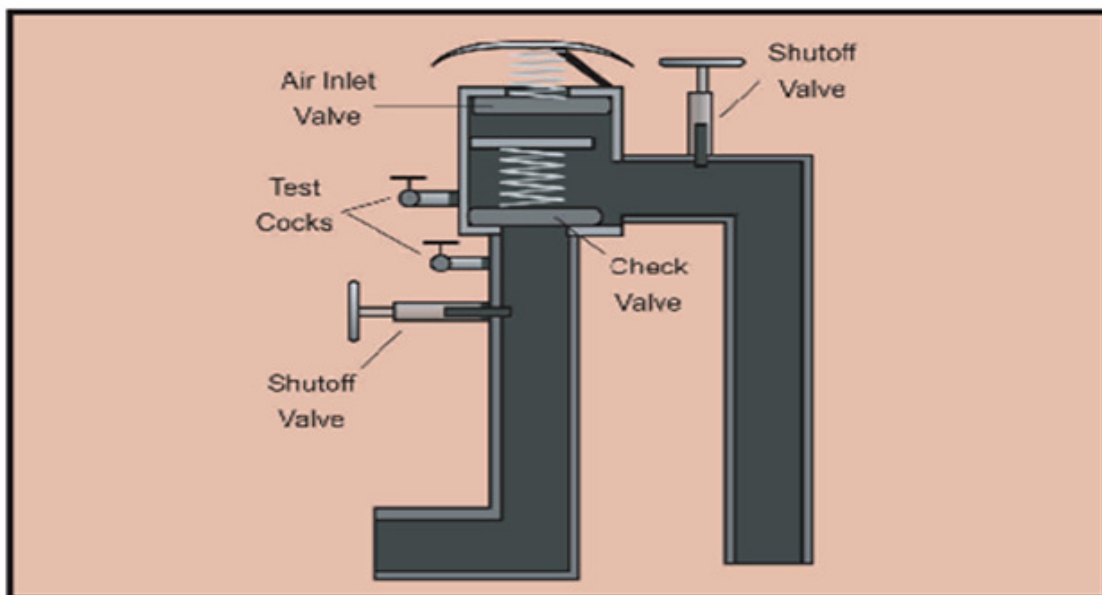

8.4.3 Figure 1: Pressure vacuum breaker assembly (PVB)

### ***ATMOSPHERIC VACUUM BREAKER (AVB)***

- Similar in design to a PVB
- Cannot be used in a continuous pressure application, 12 hours maximum
- Should not be installed in a pit or vault and needs to be exposed to the atmosphere
- Must be installed at least 6 inches above use

Protects against backsiphonage only

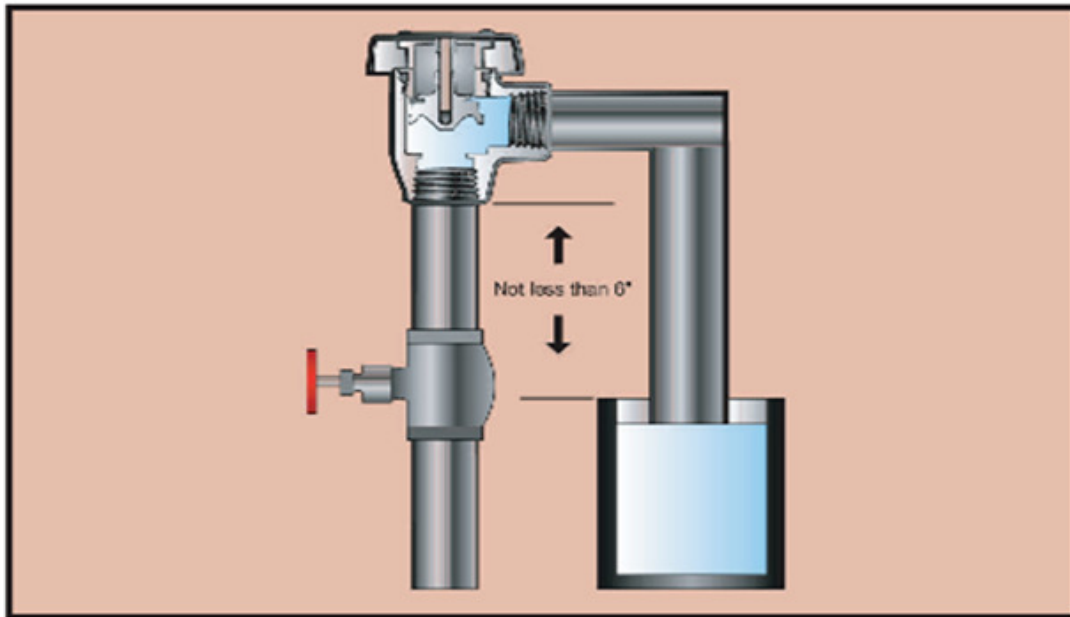

8.4.2 Figure 1: Atmospheric vacuum breaker (AVB)

**HOSE BIB VACUUM BREAKER**

- Protects against backsiphonage only
- Inexpensive device to protect premise plumbing from backsiphonage emanating from a hose attached to your premise plumbing.

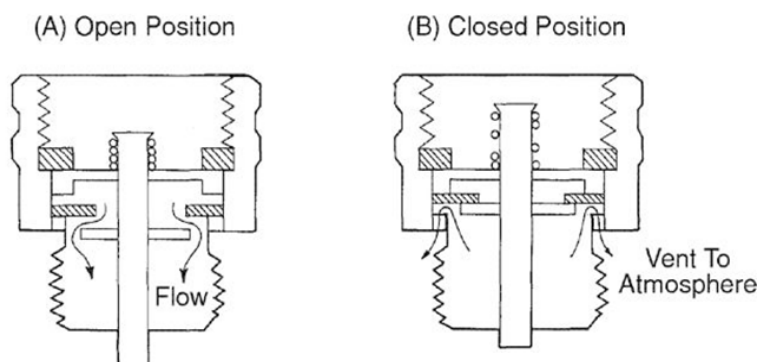

The AWWARF (2561) sent out a questionnaire to water companies to determine the extent of backflow incidents. There were between 2800 and 4100 backflow incidents reported from those who responded to the questionnaire. Of those incidents, 1100 – 1750 are documented backflow incidents. But, only half of the water systems replied to the questionnaire. If we were to extrapolate or carry out that data to its logical numerical conclusion, it would mean that anywhere from 800,000 – 1,000,000 backflow incidents could have occurred since 1970.

It is difficult to find something you aren't looking for. Many experts contend that most backflow incidents go unnoticed by the consumer. Most backflow events are transient in nature so they can easily go unnoticed. Backflow is very hard to trace to its origin. Backflow is real and happens much more frequently than we are aware of. The reasons behind backflow occurrence are many:

- Power outages
- Broken mains
- "Displaced" fire hydrants, pumps, etc
- Pump testing
- System flushing

If a backflow incident occurs in your system and some consumers of your water got sick or died, who would be legally responsible? Public water purveyors (suppliers) fall under the **Safe Drinking Water Act** which states that you, as a water supplier to the public, are to provide potable water to your customers. No doubt everyone would be sued, but the final responsibility is ours as public water systems. Our state regulations prohibit all cross connections. If one occurs in your system, you would hope you have a program in place.

Backflow is real and happens all the time. It would seem it would be beneficial to be proactive as opposed to reactive regarding backflow.

The hazards of backflow fall into three categories.

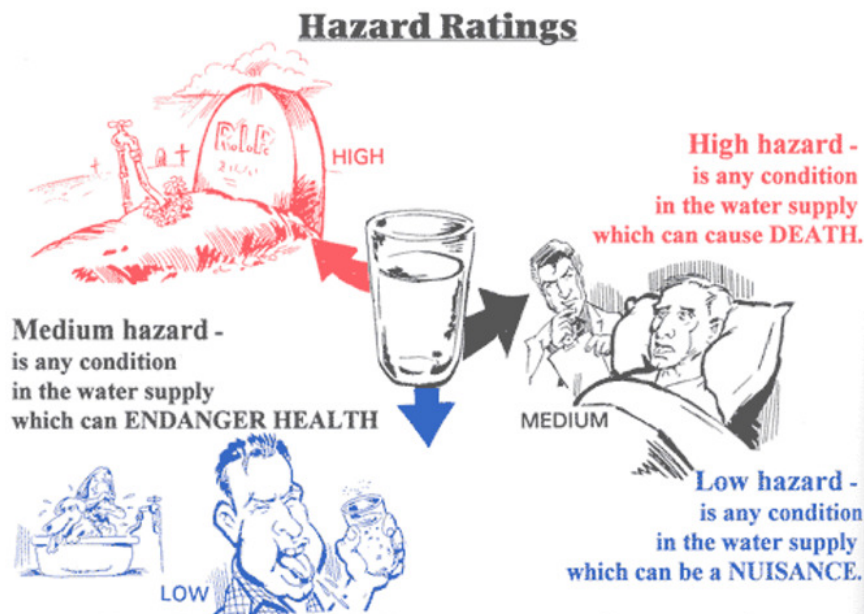

### Selection of Backflow Prevention Devices

First it is necessary to identify the hazards within the property.

Upstream from these hazards, the water is considered as non-potable until a suitable backflow prevention device is installed.

It may be necessary to install a backflow prevention device for a fixture, a zone within a building, or at the boundary of the property.

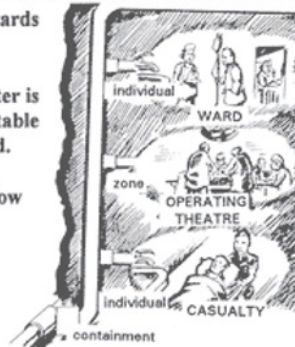



	<b>AIR GAP</b>	<b>REDUCED PRESSURE ZONE</b>	<b>DOUBLE CHECK VALVE</b>	<b>PRESSURE VACUUM BREAKER</b>	<b>ATMOSPHERIC VACUUM BREAKER</b>	
<b>Back Pressure</b>	YES	YES	NO	NO	NO	<b>Health Hazard</b>
	YES	YES	YES	NO	NO	<b>Non Health Hazard</b>
<b>Back - Siphonage</b>	YES	YES	NO	YES	YES	<b>Health Hazard</b>
	YES	YES	YES	YES	YES	<b>Non Health Hazard</b>

All cross connections are prohibited. The use of automatic devices, such as reduced pressure zone backflow preventers and vacuum breakers, may be approved by the cabinet in lieu of proper air gap separation. A combination of air gap separation and automatic devices shall be required if determined by the cabinet to be necessary due to the degree of hazard to public health. Every public water system shall determine if or where cross-connections exist and shall immediately eliminate them. (401 KAR 8:020 Sec 2 (2))

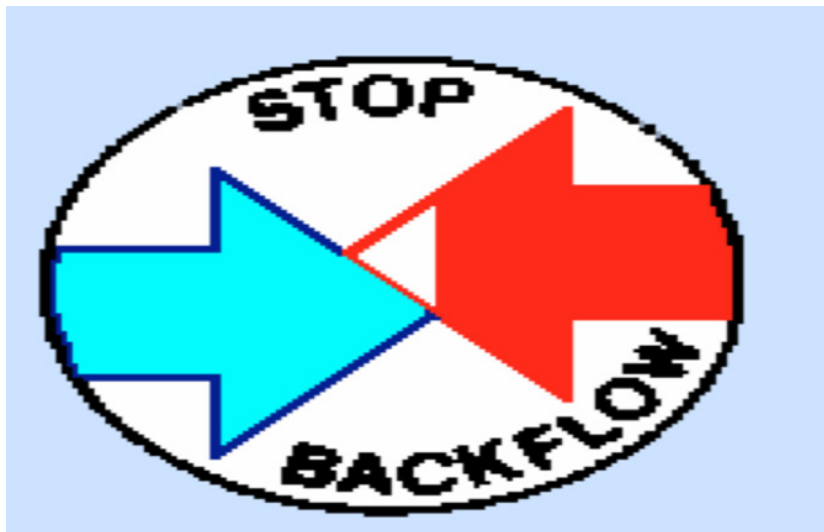

## *Examples of Cross Connection Hazard Surveys*



### Prevalence of Cross-Connections in Household Plumbing

**Survey Form**

USC ID # \_\_\_\_\_

**Survey Location**

Name Mr. Mrs. Miss \_\_\_\_\_

Street Address \_\_\_\_\_

City \_\_\_\_\_ State \_\_\_\_\_ Zip \_\_\_\_\_

Phone (\_\_\_\_) \_\_\_\_\_ FAX (\_\_\_\_) \_\_\_\_\_

Contact person upon arrival Mr. Mrs. Miss \_\_\_\_\_

Arrival Time \_\_\_\_\_ am/pm      Departure Time \_\_\_\_\_ am/pm

**Service Connection(s) & Number**

**Water Meter Size**

- |   |   |
|---|---|
| <input type="checkbox"/> Domestic _____<br><input type="checkbox"/> Irrigation _____<br><input type="checkbox"/> Fire _____ | <input type="checkbox"/> 5/8" <input type="checkbox"/> " <input type="checkbox"/> 1" <input type="checkbox"/> other _____<br><input type="checkbox"/> 5/8" <input type="checkbox"/> " <input type="checkbox"/> 1" <input type="checkbox"/> other _____<br><input type="checkbox"/> 5/8" <input type="checkbox"/> " <input type="checkbox"/> 1" <input type="checkbox"/> other _____ |
|---|---|

Building Height - Number of Stories:    One    Two    Three  
 Basement:    Yes    No

Water Usage	Cross-Connection? <i>No</i> <i>Yes - Direct or Indirect</i>			Protection <i>AG, AVB, PVB, SVB, RP, DC, DuCh, DCAP</i> <i>(1)</i>	Installation Acceptable <i>(2)</i>		Permanent or Temporary <i>(3)</i>	
	No	Dir	Ind		Yes	No	Perm	Temp
<input type="checkbox"/> <b>Auxiliary water supply</b>								
<input type="checkbox"/> Water well- pressure tank	<input type="checkbox"/>	<input type="checkbox"/>	<input type="checkbox"/>		<input type="checkbox"/>	<input type="checkbox"/>	<input type="checkbox"/>	<input type="checkbox"/>
<input type="checkbox"/> Storage tank	<input type="checkbox"/>	<input type="checkbox"/>	<input type="checkbox"/>		<input type="checkbox"/>	<input type="checkbox"/>	<input type="checkbox"/>	<input type="checkbox"/>
<input type="checkbox"/> Other _____	<input type="checkbox"/>	<input type="checkbox"/>	<input type="checkbox"/>		<input type="checkbox"/>	<input type="checkbox"/>	<input type="checkbox"/>	<input type="checkbox"/>
Comments:								
<input type="checkbox"/> <b>Fire Sprinkler System</b>								
<input type="checkbox"/> Anti-freeze	<input type="checkbox"/>	<input type="checkbox"/>	<input type="checkbox"/>		<input type="checkbox"/>	<input type="checkbox"/>	<input type="checkbox"/>	<input type="checkbox"/>
<input type="checkbox"/> Storage tank	<input type="checkbox"/>	<input type="checkbox"/>	<input type="checkbox"/>		<input type="checkbox"/>	<input type="checkbox"/>	<input type="checkbox"/>	<input type="checkbox"/>
<input type="checkbox"/> Other _____	<input type="checkbox"/>	<input type="checkbox"/>	<input type="checkbox"/>		<input type="checkbox"/>	<input type="checkbox"/>	<input type="checkbox"/>	<input type="checkbox"/>
Comments:								
<input type="checkbox"/> <b>Irrigation System</b>								
<input type="checkbox"/> Chemical Injection	<input type="checkbox"/>	<input type="checkbox"/>	<input type="checkbox"/>		<input type="checkbox"/>	<input type="checkbox"/>	<input type="checkbox"/>	<input type="checkbox"/>
<input type="checkbox"/> Booster Pumps	<input type="checkbox"/>	<input type="checkbox"/>	<input type="checkbox"/>		<input type="checkbox"/>	<input type="checkbox"/>	<input type="checkbox"/>	<input type="checkbox"/>
<input type="checkbox"/> Other _____	<input type="checkbox"/>	<input type="checkbox"/>	<input type="checkbox"/>		<input type="checkbox"/>	<input type="checkbox"/>	<input type="checkbox"/>	<input type="checkbox"/>
Comments:								

SURFACE WATER TREATMENT OPERATOR CERTIFICATION

Water Usage	Cross-Conn			Type of Protection	Proper		Perm	Temp
	No	Dir	Ind		Yes	No		
<input type="checkbox"/> Heating/Cooling Equipment								
<input type="checkbox"/> Water Heater T & P Valve <input type="checkbox"/> Yes <input type="checkbox"/> No	<input type="checkbox"/>	<input type="checkbox"/>	<input type="checkbox"/>		<input type="checkbox"/>	<input type="checkbox"/>	<input type="checkbox"/>	<input type="checkbox"/>
<input type="checkbox"/> Boiler	<input type="checkbox"/>	<input type="checkbox"/>	<input type="checkbox"/>		<input type="checkbox"/>	<input type="checkbox"/>	<input type="checkbox"/>	<input type="checkbox"/>
<input type="checkbox"/> Geo-thermal heating	<input type="checkbox"/>	<input type="checkbox"/>	<input type="checkbox"/>		<input type="checkbox"/>	<input type="checkbox"/>	<input type="checkbox"/>	<input type="checkbox"/>
<input type="checkbox"/> Heat Exchanger	<input type="checkbox"/>	<input type="checkbox"/>	<input type="checkbox"/>		<input type="checkbox"/>	<input type="checkbox"/>	<input type="checkbox"/>	<input type="checkbox"/>
<input type="checkbox"/> Humidifier	<input type="checkbox"/>	<input type="checkbox"/>	<input type="checkbox"/>		<input type="checkbox"/>	<input type="checkbox"/>	<input type="checkbox"/>	<input type="checkbox"/>
<input type="checkbox"/> Hydronic Heat	<input type="checkbox"/>	<input type="checkbox"/>	<input type="checkbox"/>		<input type="checkbox"/>	<input type="checkbox"/>	<input type="checkbox"/>	<input type="checkbox"/>
<input type="checkbox"/> Snow Melt System	<input type="checkbox"/>	<input type="checkbox"/>	<input type="checkbox"/>		<input type="checkbox"/>	<input type="checkbox"/>	<input type="checkbox"/>	<input type="checkbox"/>
<input type="checkbox"/> Solar Heating	<input type="checkbox"/>	<input type="checkbox"/>	<input type="checkbox"/>		<input type="checkbox"/>	<input type="checkbox"/>	<input type="checkbox"/>	<input type="checkbox"/>
<input type="checkbox"/> Water cooled equip	<input type="checkbox"/>	<input type="checkbox"/>	<input type="checkbox"/>		<input type="checkbox"/>	<input type="checkbox"/>	<input type="checkbox"/>	<input type="checkbox"/>
<input type="checkbox"/> Other _____	<input type="checkbox"/>	<input type="checkbox"/>	<input type="checkbox"/>		<input type="checkbox"/>	<input type="checkbox"/>	<input type="checkbox"/>	<input type="checkbox"/>
Comments:								
<input type="checkbox"/> Kitchen Facilities								
<input type="checkbox"/> Faucet	<input type="checkbox"/>	<input type="checkbox"/>	<input type="checkbox"/>		<input type="checkbox"/>	<input type="checkbox"/>	<input type="checkbox"/>	<input type="checkbox"/>
<input type="checkbox"/> Pull out spray head	<input type="checkbox"/>	<input type="checkbox"/>	<input type="checkbox"/>		<input type="checkbox"/>	<input type="checkbox"/>	<input type="checkbox"/>	<input type="checkbox"/>
<input type="checkbox"/> Dishwasher - Inlet	<input type="checkbox"/>	<input type="checkbox"/>	<input type="checkbox"/>		<input type="checkbox"/>	<input type="checkbox"/>	<input type="checkbox"/>	<input type="checkbox"/>
<input type="checkbox"/> Outlet	<input type="checkbox"/>	<input type="checkbox"/>	<input type="checkbox"/>		<input type="checkbox"/>	<input type="checkbox"/>	<input type="checkbox"/>	<input type="checkbox"/>
<input type="checkbox"/> Icemaker	<input type="checkbox"/>	<input type="checkbox"/>	<input type="checkbox"/>		<input type="checkbox"/>	<input type="checkbox"/>	<input type="checkbox"/>	<input type="checkbox"/>
<input type="checkbox"/> Other _____	<input type="checkbox"/>	<input type="checkbox"/>	<input type="checkbox"/>		<input type="checkbox"/>	<input type="checkbox"/>	<input type="checkbox"/>	<input type="checkbox"/>
Comments:								
<input type="checkbox"/> Laundry								
<input type="checkbox"/> Washing machine	<input type="checkbox"/>	<input type="checkbox"/>	<input type="checkbox"/>		<input type="checkbox"/>	<input type="checkbox"/>	<input type="checkbox"/>	<input type="checkbox"/>
<input type="checkbox"/> Wash Sink	<input type="checkbox"/>	<input type="checkbox"/>	<input type="checkbox"/>		<input type="checkbox"/>	<input type="checkbox"/>	<input type="checkbox"/>	<input type="checkbox"/>
<input type="checkbox"/> Portable Equipment	<input type="checkbox"/>	<input type="checkbox"/>	<input type="checkbox"/>		<input type="checkbox"/>	<input type="checkbox"/>	<input type="checkbox"/>	<input type="checkbox"/>
<input type="checkbox"/> Other _____	<input type="checkbox"/>	<input type="checkbox"/>	<input type="checkbox"/>		<input type="checkbox"/>	<input type="checkbox"/>	<input type="checkbox"/>	<input type="checkbox"/>
Comments:								
<input type="checkbox"/> Sewage System								
<input type="checkbox"/> Sewage Ejectors	<input type="checkbox"/>	<input type="checkbox"/>	<input type="checkbox"/>		<input type="checkbox"/>	<input type="checkbox"/>	<input type="checkbox"/>	<input type="checkbox"/>
<input type="checkbox"/> RV Flushing Facilities	<input type="checkbox"/>	<input type="checkbox"/>	<input type="checkbox"/>		<input type="checkbox"/>	<input type="checkbox"/>	<input type="checkbox"/>	<input type="checkbox"/>
<input type="checkbox"/> Bathroom #1 - Sink	<input type="checkbox"/>	<input type="checkbox"/>	<input type="checkbox"/>		<input type="checkbox"/>	<input type="checkbox"/>	<input type="checkbox"/>	<input type="checkbox"/>
<input type="checkbox"/> Bathtub/Shower	<input type="checkbox"/>	<input type="checkbox"/>	<input type="checkbox"/>		<input type="checkbox"/>	<input type="checkbox"/>	<input type="checkbox"/>	<input type="checkbox"/>
<input type="checkbox"/> Toilet/Bidet	<input type="checkbox"/>	<input type="checkbox"/>	<input type="checkbox"/>		<input type="checkbox"/>	<input type="checkbox"/>	<input type="checkbox"/>	<input type="checkbox"/>
<input type="checkbox"/> Bathroom #2 - Sink	<input type="checkbox"/>	<input type="checkbox"/>	<input type="checkbox"/>		<input type="checkbox"/>	<input type="checkbox"/>	<input type="checkbox"/>	<input type="checkbox"/>
<input type="checkbox"/> Bathtub/Shower	<input type="checkbox"/>	<input type="checkbox"/>	<input type="checkbox"/>		<input type="checkbox"/>	<input type="checkbox"/>	<input type="checkbox"/>	<input type="checkbox"/>
<input type="checkbox"/> Toilet/Bidet	<input type="checkbox"/>	<input type="checkbox"/>	<input type="checkbox"/>		<input type="checkbox"/>	<input type="checkbox"/>	<input type="checkbox"/>	<input type="checkbox"/>
<input type="checkbox"/> Bathroom #3 - Sink	<input type="checkbox"/>	<input type="checkbox"/>	<input type="checkbox"/>		<input type="checkbox"/>	<input type="checkbox"/>	<input type="checkbox"/>	<input type="checkbox"/>
<input type="checkbox"/> Bathtub/Shower	<input type="checkbox"/>	<input type="checkbox"/>	<input type="checkbox"/>		<input type="checkbox"/>	<input type="checkbox"/>	<input type="checkbox"/>	<input type="checkbox"/>
<input type="checkbox"/> Toilet/Bidet	<input type="checkbox"/>	<input type="checkbox"/>	<input type="checkbox"/>		<input type="checkbox"/>	<input type="checkbox"/>	<input type="checkbox"/>	<input type="checkbox"/>
<input type="checkbox"/> Other _____	<input type="checkbox"/>	<input type="checkbox"/>	<input type="checkbox"/>		<input type="checkbox"/>	<input type="checkbox"/>	<input type="checkbox"/>	<input type="checkbox"/>
Comments:								

SURFACE WATER TREATMENT OPERATOR CERTIFICATION

---

Water Usage	Cross-Conn			Type of Protection	Proper		Perm	Temp
	No	Dir	Ind		Yes	No		
<input type="checkbox"/> Swimming Pool/Spa								
<input type="checkbox"/> Fill Line	<input type="checkbox"/>	<input type="checkbox"/>	<input type="checkbox"/>		<input type="checkbox"/>	<input type="checkbox"/>	<input type="checkbox"/>	<input type="checkbox"/>
<input type="checkbox"/> Other _____	<input type="checkbox"/>	<input type="checkbox"/>	<input type="checkbox"/>		<input type="checkbox"/>	<input type="checkbox"/>	<input type="checkbox"/>	<input type="checkbox"/>
Comments:								
<input type="checkbox"/> Tanks, Vats, other Vessels								
<input type="checkbox"/> Water Softener - Inlet	<input type="checkbox"/>	<input type="checkbox"/>	<input type="checkbox"/>		<input type="checkbox"/>	<input type="checkbox"/>	<input type="checkbox"/>	<input type="checkbox"/>
Outlet	<input type="checkbox"/>	<input type="checkbox"/>	<input type="checkbox"/>		<input type="checkbox"/>	<input type="checkbox"/>	<input type="checkbox"/>	<input type="checkbox"/>
<input type="checkbox"/> Other _____	<input type="checkbox"/>	<input type="checkbox"/>	<input type="checkbox"/>		<input type="checkbox"/>	<input type="checkbox"/>	<input type="checkbox"/>	<input type="checkbox"/>
Comments:								
<input type="checkbox"/> Outdoor Hose bibbs								
<input type="checkbox"/> #1 -	<input type="checkbox"/>	<input type="checkbox"/>	<input type="checkbox"/>		<input type="checkbox"/>	<input type="checkbox"/>	<input type="checkbox"/>	<input type="checkbox"/>
<input type="checkbox"/> #2 -	<input type="checkbox"/>	<input type="checkbox"/>	<input type="checkbox"/>		<input type="checkbox"/>	<input type="checkbox"/>	<input type="checkbox"/>	<input type="checkbox"/>
<input type="checkbox"/> #3 -	<input type="checkbox"/>	<input type="checkbox"/>	<input type="checkbox"/>		<input type="checkbox"/>	<input type="checkbox"/>	<input type="checkbox"/>	<input type="checkbox"/>
<input type="checkbox"/> #4 -	<input type="checkbox"/>	<input type="checkbox"/>	<input type="checkbox"/>		<input type="checkbox"/>	<input type="checkbox"/>	<input type="checkbox"/>	<input type="checkbox"/>
<input type="checkbox"/> Other _____	<input type="checkbox"/>	<input type="checkbox"/>	<input type="checkbox"/>		<input type="checkbox"/>	<input type="checkbox"/>	<input type="checkbox"/>	<input type="checkbox"/>
Comments:								

**Other Actual or Potential Cross-Connections :**

\_\_\_\_\_

\_\_\_\_\_

Type of Chemicals observed on-site:

\_\_\_\_\_

\_\_\_\_\_

<p><b>All internal cross-connections protected?</b></p> <p><input type="checkbox"/> Yes</p> <p><input type="checkbox"/> No</p>	<p>Surveyor _____</p> <p>Signature _____</p> <p>Date of Survey _____</p>
--	--

<p><u><b>USC Research Team</b></u> <u>Data Base</u></p> <p><u>Type of Cross-Conn</u> _____</p>	<p><u>Transferred to</u></p> <p><u>Hazard</u></p> <p><u>Date:</u></p>
--	---

# Cross-Connection Survey Form

Date: \_\_\_\_\_

Name of Company, Corporation, or Business: \_\_\_\_\_

Address: \_\_\_\_\_

Name of Contact: \_\_\_\_\_

Type of Use:    Industrial \_\_\_\_\_    Commercial \_\_\_\_\_    Governmental \_\_\_\_\_    Other \_\_\_\_\_

Location of Service: \_\_\_\_\_

Size of Service: \_\_\_\_\_ Inch                                      Metered?                      Yes                       No

Require non-interrupted water service?                                      Yes                       No

Does Boiler Feed utilize chemical additives?                                      Yes                       No

    Is Backflow protection incorporated?                                      Yes                       No

Are air conditioning cooling towers utilized?                                      Yes                       No

    Is Backflow protection incorporated?                                      Yes                       No

Is a Water Saver utilized on condensing lines or cooling towers?                      N/A                       Yes                       No

    Is the make-up supply line backflow protected?                                      Yes                       No

Is process water in use, and if so, is it potable supply water or "Raw" water                                      N/A                       Potable

    Raw                       Protected                       Unprotected

Is fire protection water separate from the potable supply?                                      Yes                       No

Are Containment Devices in place?                                      Yes                       No

## Summary

Degree of Hazard:    High                                       Low

Type of Device recommended for containment:                                      RPZ                                       DCV                                       None

Fixture Outlet protection required?                                      Yes                                       No

If so, where? \_\_\_\_\_

***Review Questions for Chapter 15 – Cross Connections***

1. What has caused more waterborne illnesses than any other factor in the US during the last twenty years?
2. Identify the two forms of backflow.
3. What are the two types of backflow protection programs or approaches?
4. Name three situations in which backflow could occur in almost any system.
5. What is the most reliable **mechanical** device for backflow protection?
6. Single check valves can be used for backflow prevention. T or F
7. An air gap must be how many times the inside diameter of whatever pipe it serves.

***Answers to Review Questions for Chapter 15 - Cross Connections***

1. backflow (cross connections)
2. backsiphonage & backpressure
3. Isolation and Containment
4. power outages, broken water mains, malfunctioning or broken hydrants, pumps, etc., pump testing, system flushing
5. RPZ (reduced pressure zone)
6. False
7. 2 times the ID

This page left blank intentionally.



# GLOSSARY

- absorption – The uptake of water or dissolved chemicals by a cell or an organism.
- acidic – The condition of water or soil which contains a sufficient amount of acid substances to lower the pH below 7.0.
- acre-foot – A volume of water that covers one acre to a depth of one foot, or 43, 560 ft<sup>3</sup>.
- action level – The level of lead or copper which, if exceeded, triggers treatment or other requirements that a water system must follow.
- acute health effect – An immediate (i.e. within hours or days) effect that may result from exposure to certain drinking water contaminants (e.g., pathogens).
- adsorption – The process by which chemicals are held on the surface of a mineral or soil particle.
- aeration – The process of adding air to water. Air can be added to water by either passing air through water or passing water through air.
- aerobic – A condition in which “free” (atmospheric) or dissolved oxygen is present in the water.
- air binding – A situation where air enters the filter media. Air can prevent the passage of water during the filtration process and cause a loss of filter media during the backwash cycle.
- air bladder – A flexible container located on the inside of a hydropneumatic tank to hold air.
- air gap – An open vertical drop, or vertical empty space, that separates a drinking (potable) water supply from another water system.
- air stripping – A treatment process used to remove dissolved gases and volatile substances from water. Large volumes of air are bubbled through the water being treated to remove (strip out) the dissolved gasses and volatile substances. (See packed tower aeration)

- algae – Microscopic plants which contain chlorophyll and live floating or suspended in water. Their biological activities appreciably affect the pH and dissolved oxygen content of the water because they produce oxygen during sunlight hours and use oxygen during the night.
- alkalinity – The capacity of water to neutralize acids.
- ambient – Environmental or surrounding conditions.
- anaerobic – A condition in which “free” (atmospheric) or dissolved oxygen is NOT present in water.
- anionic polymer – A polymer having negatively charged groups of ions; often used as a filter aid or for dewatering sludge.
- anode – The positive pole or electrode of an electrolytic system, such as a battery. The anode attracts negatively charged particles or ions. (anions)
- AOC – assimilable organic carbon – low molecular weight dissolved organic carbon (DOC)
- appurtenance – Structures and other parts of the main structure necessary to allow it to operate as intended, but not considered part of the main structure.
- available chlorine – A measure of the amount of chlorine available in materials that are used as a source of chlorine when compared with that of elemental (gaseous or liquid) chlorine.
- aquifer – A natural underground layer of porous, water-bearing materials.
- artesian – Water held under pressure in porous rock or soil confined by impermeable geologic formations. An artesian well is free flowing.
- backpressure – A pressure that can cause water to backflow into the potable water supply when a customer’s system is at a higher pressure than the public potable system.
- backflow – Flow in the opposite direction to the normal flow direction or the flowing back of a substance toward its source.

- backsiphonage – A type of backflow caused by negative pressure within a water system.
- backwashing – The process of reversing the flow of water back through the filter media to remove entrapped solids.
- baffles – A flat board or plate, deflector, or similar device constructed or placed in flowing water to cause more uniform flow velocities, to absorb energy, or to divert, guide, or agitate liquids.
- Best Available Technology – The water treatment(s) that the EPA certifies to be the most effective for removing a contaminant.
- Best Management Practices – Structural, nonstructural, and managerial techniques that are recognized to be the most effective and practical means to control the productive use of the resource to which they are applied.
- biofilm – An organic slime that grows on the inside of pipes, on filter media, or anywhere aqueous solutions are pervasive.
- biodegradation – decomposition of a substance into more elementary compounds by the actions of microorganisms such as bacteria
- brake horsepower – 1) the horsepower required at the top or end of a pump shaft (input to a pump). 2) The energy provided by a motor or other power source.
- breakpoint chlorination – Addition of chlorine to water until the chlorine demand has been satisfied. At this point, further additions of chlorine will result in free residual chlorine that is directly proportional to the amount of chlorine added beyond breakpoint.
- breakthrough – A crack or break in a filter bed allowing the passage of floc or particulate matter through a filter.
- $\text{CaCO}_3$  – calcium carbonate
- $\text{CO}_2$  – carbon dioxide

- C Factor – A factor of value used to indicate the smoothness of the interior of a pipe. The higher the C Factor, the smoother the pipe, the greater the carrying capacity, and the smaller the friction or energy losses occur from water flowing in the pipe.
- Capacity Development – A program developed by the USEPA and administered by the Kentucky DOW that determines the financial, technical, and managerial viability of water systems.
- capillary fringe – The porous material just above the water table which may hold water by capillarity (a property of surface tension that draws water upwards) in the smaller void.
- capital costs – Costs (usually long term) of financing construction and equipment.
- cathode – The negative pole or electrode of an electrolytic cell or system. The cathode attracts positively charged particles or ions (cations).
- cathodic protection – An electrical system for prevention of rust, corrosion, and pitting of metal surfaces which are in contact with water or soil. This practice can concentrate corrosion on auxiliary anodic parts which are deliberately sacrificed and allowed to corrode instead of letting the structure corrode.
- cationic polymer – A polymer having positively charged groups of ions; often used as a coagulant aid.
- cations – an ion that has a positive electric charge and is attracted toward the cathode in electrolysis
- cavitation – The formation and collapse of a gas pocket or bubble on the blade of an impeller. The collapse of this pocket or bubble drives water into the impeller with a terrific force that can cause pitting on the impeller. Cavitation is accompanied by loud noises that sound like someone is pounding on the impeller with a hammer.
- centrifugal pump – A pump consisting of an impeller fixed on a rotating shaft that is enclosed in a casing, and having an inlet and discharge connection.
- check valve – A valve with a hinged disc or flap that opens in the direction of flow and closing when the flow is reversed.

- chlorinate – The process of adding chlorine to water.
- chloramines – Compounds formed by the reaction of aqueous chlorine with ammonia.
- chlorine demand – The difference between the amount of chlorine added to water and the amount of residual chlorine remaining after a given contact time.
- chlororganic – Organic compounds combined with chlorine. These compounds generally originate from, or are associated with, life processes such as those of algae in water.
- chronic – Occurring over a long period of time.
- chronic health effect – The possible result of exposure over many years to a drinking water contaminant at levels above its MCL.
- circle of influence – The circular outer edge of a depression produced in the water table by the pumping of water from a well. (aka: zone of influence)
- clarification - to make a liquid clear either by settling or filtration.
- clarifier – A large circular or rectangular tank or basin in which water is held for a period of time, during which the heavier suspended solids settle to the bottom. (aka settling basins and sedimentation basins)
- class – The working pressure rating of a specific pipe for use in water distribution systems. This term is used for cast iron, ductile iron, asbestos cement and most plastic pipes.
- clear well – A reservoir for the storage of filtered water of sufficient capacity to prevent the need to vary the filtration rate with variations in demand. Also used to provide chlorine contact time for disinfection.
- coagulants – Chemicals that cause very fine particles to clump together into larger particles.

- coagulation – The clumping together of very fine particles caused by the use of chemicals (coagulants). The chemicals neutralize the electrical charges of the fine particles and cause destabilization of the particles.
- coliform – A group of related bacteria whose presence in drinking water may indicate contamination by disease-causing microorganisms.
- colloids – Very small particles that do not quickly dissolve that remain dispersed in a liquid for a long time due to their small size and electrical charge.
- combined available residual chlorine – The concentration of residual chlorine which is combined with ammonia (NH<sub>3</sub>) and/or organic nitrogen in water as a chloramine (or other chloro derivative) yet is still available to oxidize organic matter and utilize its bactericidal properties.
- community water system (CWS) – A water system which supplies drinking water to 25 or more of the same people year-round in their residences.
- composite sample – A composite sample is a collection of individual samples obtained at regular intervals during a 24 – hour time span.
- compliance – The act of meeting all state and federal drinking water regulations.
- compound – A substance composed of two or more elements whose composition is constant. i.e. table salt, sodium chloride, is a compound.
- cone of depression – The depression, roughly conical in shape, produced in the water table by pumping of water from a well.
- confined aquifer – an aquifer that is covered by an impermeable or semi-permeable layer of rock.
- contaminant – Anything found in water (including microorganisms, minerals, chemicals, radionuclides, etc.) which may be harmful to human health.
- corrosion – The gradual decomposition of a material by chemical action.
- corrosion inhibitor – Substances that slow the rate of corrosion by forming a protective film on the interior surface of the materials.

- cross connection – a physical link between potable water and one of unknown or questionable quality.
- Cryptosporidium – A microorganism commonly found in lakes and rivers which is highly resistant to disinfection.
- CT – The product of “residual disinfectant concentration” (C) in mg/L (ppm) determined before or at the first customer, and the corresponding “disinfectant contact time (T) in minutes.
- day tank – A tank used to store a chemical solution of known concentration for feed to a chemical feeder.
- dead end – The end of a water main which is not connected to other parts of the distribution system by means of a connecting pipe or loop.
- dechlorination – The deliberate removal of chlorine from water. The partial or complete reduction of residual chlorine by any chemical or physical process.
- denitrification – The biochemical conversion of nitrate and nitrite nitrogen dissolved in water to gaseous nitrogen.
- desalinization – The removal of dissolved salts from water by specific water treatment processes.
- Detention Time (DT) – 1) The theoretical (calculated) time required for a small amount of water to pass through a tank at a given rate of flow.  
Volume (gallons) ÷ Flow (gpm)
- discharge head – The pressure (in pounds per square inch or psi) measured at the centerline of a pump discharge converted into feet. (1 psi = 2.31 feet of head)
- disinfectant – Any oxidant – including but not limited to chlorine that is added to water in any part of the treatment or distribution process and is intended to kill or inactivate pathogenic microorganisms

- disinfectant contact time (The “T” in CT calculation) - The time in minutes that it takes for water to move from the point of disinfection application or the previous point of disinfectant residual measurement to a point before or at the point where residual disinfectant concentration (C) is measured. Disinfectant contact time in pipelines must be calculated based on plug flow by dividing the internal volume of the pipe by the maximum hourly flow rate through that pipe.
- disinfection – A chemical or physical process that kills or interrupts the life cycle of microorganisms such as bacteria, viruses, and protozoa.
- dissolved oxygen (DO) – A measure of water quality indicating free oxygen dissolved in water.
- distribution system – A network of pipes leading from a treatment plant to customers’ plumbing systems.
- divalent – a divalent ion or molecule has a valence of two and thus can form two covalent bonds with other ions or molecules
- dosage – The quantity of a chemical administered to an organism.
- dose – The actual quantity of a chemical added to the water to which an organism is exposed.
- DPD – DPD stands for N, N-diethyl-p-phenylene-diamine A method of measuring the chlorine residual in water.
- eductor – A hydraulic device used to create a negative pressure (suction) by forcing or drawing liquid through a restrictor, such as a Venturi meter.
- effluent – A fluid flowing from a process or storage facility.
- electrolysis – the conduction of electricity through something dissolved in order to induce decomposition of the dissolved chemical into its components
- electron – An extremely small, negatively charged particle, the part of an atom that determines its chemical properties.
- enteric – Of intestinal origin, especially applied to wastes or bacteria.



- Environmental Protection Agency (EPA) – The Federal agency that determines and enforces, among other things, drinking water standards for the United States and its territories.
- epilimnion – The upper layer of water in a thermally stratified lake or reservoir.
- eutrophic – Reservoirs and lakes which are rich in nutrients and very productive in terms of aquatic animal and/or plant life.
- extrapolation – The estimation of unknown values by extending or projecting from known values.
- fecal coliform bacteria – Bacteria found in the intestinal tracts of animals. Their presence in water is an indicator of possible contamination by pathogens.
- ferric – containing iron, with a valence of three
- ferrous – relating to or containing iron
- filtration – A process for removing particulate matter from water by passage through porous media.
- finished water – Water that has been treated and is ready to be delivered to customers.
- first draw – The water that immediately comes out when a tap is first opened.
- floc – Clumps of bacteria and particulate impurities that have grouped together and formed a cluster.
- flocculation – The gathering together of fine particles in water by gentle mixing after the addition of coagulant chemicals to form larger particles.
- flushing – A method used to clean water distribution lines.
- flux – A flowing or flow.
- foot valve – A type of check valve located at the bottom end of the suction pipe on a pump.

- free available residual chlorine – That portion of total available residual chlorine remaining in water after chlorination.
- free residual chlorination – The application of chlorine to water to produce a free available chlorine residual equal to at least 80 percent of the total residual chlorine (sum of free and combined available chlorine residual).
- freeboard – 1) The vertical distance from the normal water surface to the top of the confining wall. 2) The vertical distance from the sand surface to the underside of a trough in a sand filter.
- friction losses – The head, pressure or energy lost by water flowing in a pipe or channel as a result of turbulence caused by the velocity of the flowing water and the roughness of the pipe, channel walls, or any other restriction to flow such as fittings. Water flowing in a pipe loses energy as a result of friction losses.
- gage pressure – The pressure within a closed container measured without the addition of the 14.7 pounds of atmospheric pressure added in. Most pressure gages read in gage pressure or psig (pounds per square inch gage pressure).
- galvanic series – A list of metals and alloys presented in the order of their tendency to corrode.
- garnet – Hard, reddish, glassy mineral sands made up of silicates of base metals (calcium, magnesium, iron and manganese).
- Giardia lamblia – A microorganism frequently found in rivers and lakes, which, if not treated properly, may cause diarrhea, fatigue, and cramps after ingestion.
- grab sample – A single sample collected at a particular time and place which represents the composition of the water at only that time and place.
- GW – Ground Water – The supply of fresh water found beneath the earth's surface, usually in aquifers.

- GWUDI – ground water under the direct influence (of surface water) – Any water found beneath the earth’s surface with: 1) significant occurrence of insects or other macroorganisms from algae or large diameter pathogens such as Giardia lamblia or, 2) significant and relatively rapid shifts in water characteristics such as turbidity, temperature, or pH.
- HAA 5 - Haloacetic Acids (chloroacetic acid, dichloroacetic acid, trichloroacetic acid, bromoacetic acid, dibromoacetic acid)
- hard water – Alkaline water containing dissolved salts that interfere with some industrial processes and that prevent soap from lathering.
- head – The distance (in feet) equal to the pressure (in psi) at a specific point. 1 foot of head is equivalent to .433 psi.
- head loss – The head, pressure or energy (they are synonymous) lost by water flowing in a pipe or channel as a result of turbulence caused by the velocity (speed) of the flowing water and the roughness of the pipe, channel walls or restrictions caused by fittings.
- HPC – Heterotrophic Plate Count (also known as standard plate count) – The number of colonies of heterotrophic bacteria grown on selected solid media at a given temperature and incubation period, usually expressed in number of bacteria per milliliter of sample.
- hydraulic grade line (HGL) – The level water would rise to in a freely vented standpipe under pressure.
- hydropneumatic – powered by air and water
- hydropneumatic tank – A small, less than 1,000 gallon tank used by a hydropneumatic system. The tank contains air and water, typically in a 1:2 ratio air to water, i.e. 1/3 to 2/3 water.
- hydrostatic pressure – 1) The pressure at a specific elevation exerted by a body of water at rest or, 2) In the case of ground water, the pressure at a specific elevation due to the weight of water at higher levels in the same zone of saturation.

- hypochlorinators – Chlorine pumps, chemical feed pumps or devices used to dispense chlorine solutions made from hypochlorites such as sodium hypochlorite or calcium hypochlorite.
- hypolimnion – The lowest layer in a thermally stratified lake or reservoir. This layer consists of colder, denser water that has a constant temperature where no mixing occurs.
- impeller – A rotating set of vanes in a pump designed to pump water.
- impermeable – Not easily penetrated. The property of a material or soil that does not allow, or allows with great difficulty, the passage of water.
- in-line filtration – The addition of chemical coagulants directly to the filter inlet pipe commonly used in pressure filter installations.
- inorganic contaminants – Mineral-based compounds such as metals, nitrates, and asbestos that are naturally-occurring in some water. These contaminants can also get into water through farming, chemical manufacturing, and other human activities.
- insoluble – incapable of being dissolved in a liquid
- ions – an atom or group of atoms or molecules that has acquired an electric charge by losing or gaining one or more electrons
- jar test – A laboratory procedure that simulates a water treatment plant's coagulation/flocculation units with differing chemical doses and also energy of rapid mix, energy of slow mix, and settling time.
- kinetic energy – Energy possessed by a moving body of water as a result of its motion.
- Langelier index, Langelier Saturation Index (LSI) – An index reflecting the equilibrium pH of particular water with respect to calcium, alkalinity, and temperature.
- $LSI\ pH = pH_A\ (actual) - pH_S\ (saturation)$  A negative sum indicates the likelihood the water is corrosive and a positive number indicates the water has the propensity to be scale forming.

- laundering weir – Sedimentation basin overflow weir. Usually a plate with V-notches along the top to assure a uniform flow rate and avoid short-circuiting.
- leachate – a derivative from the decomposition of inorganic and organic substances.
- leaching – To remove soluble or other constituents from by action of a percolating liquid.
- $\mu$  - micro, one millionth
- $\mu\text{g/L}$  – microgram per liter, one millionth of a gram per liter.
- manganous – containing or derived from manganese
- Maximum Contaminant Level (MCL) – The highest level of a contaminant that the EPA allows in drinking water at which there are no known or anticipated adverse effect on human health.
- Maximum Contaminant Level Goal (MCLG) – See MCL. These are goals that the EPA would like to see reached for each contaminant. Maximum contaminant level goals are non-enforceable health goals.
- media migration – the movement of filter media from either where it was originally or intended in a filter bed to somewhere in the bed that is not intended
- $\text{mg/g}$  - milligrams/gram
- microgram per liter – A unit equal to parts per billion (ppb) since one liter of water is equal in weight to one billion micrograms. A microgram dissolved in one liter of water.
- micron – A unit of length that equals 0.00004 of an inch. One millionth of a meter (39.37 inches).
- microorganisms – Tiny living organisms that can be seen only with the aid of a microscope. Also known as microbes.

- milligrams per liter (mg/L) – A measure of concentration of a dissolved substance. One milligram (one-thousandth of a grain,  $3.5 \times 10^{-1}$  oz or 0.000035 oz) means that one milligram of a substance is dissolved in each liter of water. For practical purposes, this unit is equal to parts per million (ppm) since one liter of water is equal in weight to one million milligrams.
- Million Gallons per Day (MGD) – A measure of water flow.
- disinfection generated on-site from salt brine and an electrical charge.
- monitoring – Testing that water systems must perform to detect and measure contaminants. A water system that does not follow EPA's monitoring methodology or schedule is in violation, and may be subject to legal action.
- motor efficiency – The ratio of energy delivered by a motor to the energy supplied to it during a fixed period or cycle.
- mounding – filter media bunching up atop other media in a filter bed
- mudballs – Material that forms in filters and gradually increases in size when not removed by the backwashing process. This material is frequently semi-round in shape and varies from pea-sized to several inches or more in diameter.
- multi-stage pump – A pump that has more than one impeller.
- Natural Organic Matter (NOM) – Organic compounds that are formed from decomposing plant, animal, and microbial material. They can react with disinfectants to form disinfection by products. Total organic carbon (TOC) is often measured as an indicator of natural organic matter.
- nephelometric – A means of measuring turbidity in a sample using a device called a nephelometer. A nephelometer passes light through a sample and the amount of light deflected (usually at a 90-degree angle) is then measured.
- nephelometric turbidity units (NTU) – the measurement of light passing through a sample of water when using a nephelometer.
- nitrification – The biochemical transformation of ammonium nitrogen to nitrate nitrogen.

- non-community water system (NCWS) – A public water system that is not a community water system. There are two types of NCWS's: transient and non-transient
- non-transient, non-community water system (NTNCWS) – A water system which supplies water to 25 or more of the same people at least six months per year in places other than residences. Some examples are schools, factories, office buildings, and hospitals which have their own water systems.
- organics – 1) Any form of animal or plant life. 2) A term used to refer to chemical compounds made from carbon molecules.
- organic contaminants – Carbon-based chemicals, such as solvents and pesticides, which can get into water through runoff from croplands or discharges from factories.
- overall pump efficiency – Also called wire to water efficiency. The combined efficiency of a pump and a motor together.
- overflow rate – One of the guidelines for the design of settling tanks and clarifiers in treatment plants. Used by operators to determine if tanks and clarifiers are hydraulically over or under loaded. Also called surface loading.
- Surface Overflow Rate =  $\text{Flow (gpm)} \div \text{Area (sq ft)}$
- Oxidation-Reduction Potential (ORP) – The electrical potential required to transfer electrons from one compound or element (the oxidant) to another compound or element (the reductant); used as a qualitative measure of the state of oxidation in water treatment.
- pathogen – A disease-causing organism.
- ppb – parts per billion
- percolation – 1) The slow seepage of water into and through the ground. 2) The slow passage of water through a filter medium.
- permeability – The ability of rock or soil to transmit water.

- pH – A logarithmic expression of the intensity of the basic or acid condition of a liquid. Mathematically, pH is the logarithm (base 10) of the reciprocal of the hydrogen ion concentration, (H<sup>+</sup>). The pH range is from 0 to 14 where 0 is the most acidic, 14 most basic and 7 being neutral.
- phenolic compounds – Organic compounds that are derivatives of benzene.
- photosynthesis - The process in which organisms, with the aid of chlorophyll, convert carbon dioxide into oxygen, using sunlight for energy.
- pitless adaptor – A device installed in the upper portion of the well casing that allows the pump discharge line to exit the casing below the frost line.
- plug flow – A type of flow that occurs when a slug of water moves through a structure (i.e. pipe) without ever dispersing or mixing with the rest of the water.
- point-of-entry (POE) treatment device – A treatment device applied to the drinking water entering a house or building.
- point-of-use (POU) treatment device – A treatment device applied to a single tap.
- point source – A stationary location or fixed facility from which pollutants are discharged.
- pollutant – Any substance introduced into the environment that adversely affects the usefulness of that resource.
- polyelectrolyte – A high molecular weight substance having points of positive or negative electrical charges. Used with other coagulants to aid in binding small suspended particles to larger chemical flocs for their removal from water.
- polymer – A chemical formed by the union of many monomers (a molecule of low molecular weight). Used with other coagulants to aid in binding small suspended particles to larger chemical flocs for their removal from water. All polyelectrolytes are polymers but not all polymers are polyelectrolytes.
- potable water – Water that is safe for human consumption and aesthetically pleasing.
- precipitate – to cause a solid to separate out from a solution as a result of a chemical reaction



- precursor – Natural organic compounds found in all surface and ground waters. The compounds MAY react with halogens (such as chlorine) to form trihalomethanes.
- pressure head – The distance (in feet) equal to the pressure (in psi) at a specific point.
- pressure relief valve – A valve that opens automatically to release water in a pipeline when the pressure reaches an assigned limit.
- pressure zones – An area within a distribution system in which the pressure in the mains is maintained within certain limits.
- Primacy State – A State that has the responsibility and authority to administer the EPA's drinking water regulations within its borders. The rules must be at least as stringent as the EPA's.
- prime – The action of filling a pump casing with water to remove the air. Most pumps must be primed before startup or they will not pump water.
- public notification – An advisory that the EPA requires a water system to distribute to affected consumers when the system has violated MCL's or other regulations. The notice advises consumers what precautions, if any, they should take to protect their health.
- Public Water Systems (PWS) – Any water system which provides water to at least 25 people for at least 60 days a year.
- purveyor – seller, supplier, vendor
- radionuclides – Any man-made or natural element that emits radiation and that may cause cancer after many years of exposure through drinking water.
- raw water – Water in its natural state, prior to any treatment for drinking.
- recharge area – An area that is connected with an aquifer by a highly porous soil or rock layer.
- recharge rate – The quantity of water per unit of time that replenishes or refills an aquifer(s).

- representative sample – A sample of water that is as nearly identical in content and consistency as possible to that in the larger body of water being sampled.
- residual chlorine – The amount of free and/or available chlorine after a given contact time and allowed to react with all substances present in the water.
- reverse osmosis – The application of pressure or a vacuum which causes the passage of the water across a semi-permeable membrane. The membrane allows the passage of the water but not the dissolved solids (solutes).
- runoff – The part of precipitation that runs off the land into streams or other surface water.
- Safe Drinking Water Act (SDWA) – The federal law that authorizes and requires the EPA and state agencies to monitor drinking water quality.
- sample – The water that is analyzed for the presence of EPA-regulated drinking water contaminants.
- sanitary seal – A watertight seal on top of the well casing that prevents water or other liquids from entering the well.
- sanitary survey – An on-site review of the water sources, facilities, equipment, operation, and maintenance of a public water systems for the purpose of evaluating the adequacy of the facilities for producing and distributing safe drinking water.
- saturated zone – The area below the water table where all open spaces are filled with water.
- secchi disc – A flat white disc (sometimes black and white) lowered into the water until it is just visible to determine the depth of the water.
- secondary drinking water standards – Non-enforceable federal guidelines regarding cosmetic effects (such as tooth or skin discoloration) or aesthetic effects (such as taste, odor, or color) of drinking water.
- septic – A condition produced by bacteria when all oxygen supplies are depleted. Usually
- accompanied by a foul odor and a black color in the water.

- Service line sample – A one liter sample of water collected in accordance with CFR Section 141.86(b)(6) of the code of Federal Regulations, that has been standing for at least six hours in the service line.
- short-circuiting – A condition that occurs in tanks or basins when some of the water travels faster than the rest of the flowing water. This is usually undesirable since it can result in shorter contact times or settling times in comparison with the theoretical (calculated) detention times.
- single or three phase power – single phase – two sources of power 120° out of phase with each other. Three phase is three sources of power that are 120° out of phase with each other.
- slurry – a liquid mixture of water and an insoluble material
- sole source aquifer – An aquifer that supplies 50 percent or more of the drinking water of a particular area.
- specific gravity – The weight of a particle, substance, or chemical solution in relation to the weight of water (8.34 lbs/gallon).
- specific yield – The quantity of water that a unit volume of saturated permeable rock or soil will yield when drained by gravity. Specific yield may be expressed as a ratio or as a percentage by volume.
- spoil pile – Excavated material such as soil from a trench or excavation. OSHA regulations dictate that spoil piles must be kept at least two feet away from the edge of the trench.
- sounding tube – A pipe or tube used for measuring the depths of water.
- source water – Water in its natural state, prior to any treatment for drinking.
- static head – The distance, when water is not moving, from a specific point to the water surface.
- static pressure – The static pressure is the static head expressed as pressure. See above. One foot of head is equivalent to 0.433 psi.

- static water level – 1) The elevation or level of the water table in a well when the pump is not operating. 2) The level or elevation to which water would rise in a tube connected to an artesian aquifer or pipeline (conduit) under pressure.
- submergence – The distance between the water surface and the media surface in a filter.
- surface loading – see overflow rate
- surface water – The water that systems pump and treat from sources open to the atmosphere, such as rivers, lakes, and streams.
- THM – trihalomethane
- threshold odor – The minimum odor of a water sample that can just be detected after successive dilutions with odorless water. Also called odor threshold.
- thrust block – A mass of concrete or other similar material appropriately placed at a pipe to prevent the pipe from moving whenever the flow of the water changes direction or the momentum of the water is interrupted.
- titration – The process of adding the chemical reagent in increments until the completion of
- the reaction, as signaled by the end point.
- Total Coliform Rule (TCR) – A rule of the SDWA requiring systems to monitor for coliform bacteria on a monthly basis.
- total residual chlorine – The amount of available chlorine remaining after a given contact time. The sum of the combined available residual chlorine and the free available residual chlorine.
- total trihalomethanes (TTHM) – The sum of the concentration in milligrams per liter of the trihalomethane compounds (trichloromethane (chloroform), dibromochloromethane, bromodichloromethane and tribromomethane (bromoform)), rounded to two significant digits.

- transient, non-community water systems (TNCWS) – A water system which provides water in a place such as a gas station or campground where people do not remain for long periods of time. These systems do not have to test or treat their water for contaminants which pose long-term health risks because fewer than 25 people drink the water over a long period. They still must test their water for microbes and several chemicals.
- transmissivity – The ability of an aquifer to transmit water.
- transpiration – The process by which water vapor is released to the atmosphere by living plants.
- treatment technique – A required process intended to reduce the level of a contaminant in drinking water.
- trihalomethane – One of a family of organic compounds named as derivatives of methane. THMs are generally the by-product from chlorination of water that contains organic matter. The resulting compounds are suspected of causing cancer.
- TTHM – total trihalomethanes
- tube settlers – A device that uses configurations of small (2 – 3 inches) tubes installed on an incline as an aid to sedimentation. As water rises within the tubes, settling solids fall to the tube surface. As the sludge from the settled solids in these tubes gain weight, it moves down the tubes and settles to the bottom of the basin for removal by conventional sludge collection processes.
- tubercle – A crust of corrosion products (rust) that build up over a pit caused by the loss of metal due to corrosion.
- tuberculation – The formation of small mounds of corrosion products (rust) on the inside of iron pipe. These mounds increase the roughness of the inside of the pipe and reduce the capacity of the pipe to carry the same volume of water (carrying capacity) as when the pipe was free of the tuberculation.
- turbidity – The cloudy appearance of water caused by the presence of tiny particles. Turbidity particles can also shield pathogens from disinfection.
- unconfined aquifer – An aquifer containing water that is not under pressure; the water level in a well is the same as the water table outside the well.

- unsaturated zone – The area between the land surface and water table in which the pore spaces are only partially filled with water.
- UV – ultraviolet light – mercury filled lamps used to disinfect water by altering the DNA of pathogens.
- valence – the combining power of atoms or groups measured by the number of electrons the atom or group will receive, give up or share in forming a compound.
- variance – State or EPA permission not to meet a certain drinking water standard.
- Venturi – The effect when velocity increases, pressure decreases in a pipeline or educator.
- violation – A failure to meet any state or federal drinking water regulation.
- virus – The smallest form of microorganisms capable of causing disease.
- Volatile Organic Contaminant (VOC) – an organic compound that contributes to water pollution e.g. ethylene, benzene, styrene, etc.
- Vortexing – a whirling mass of water that draws everything in close proximity towards its center
- watershed – The land area from which water drains into a stream, river, or reservoir.

# APPENDIX

## Certified Drinking Water Distribution Operator Regulations

401 KAR 11:001. Definitions for 401 KAR Chapter 11.

RELATES TO: KRS 223.160-220, 224.01-010(9), 224.73-110, EO 2009-538

STATUTORY AUTHORITY: KRS 223.200, 224.10-100, 224.10-110, 224.73-110, EO 2009-538

NECESSITY, FUNCTION, AND CONFORMITY: KRS 224.10-110 authorizes the cabinet to promulgate administrative regulations concerning the certification of wastewater operators. KRS 223.200 requires the cabinet to promulgate administrative regulations concerning the certification of water treatment and distribution system operators. EO 2009-538, effective June 12, 2009, establishes the new Energy and Environment Cabinet. This administrative regulation establishes definitions applicable to the certification of wastewater and water operators.

Section 1. Definitions. (1) "Applicant" means a person who has submitted an application to take an examination for certification.

(2) "Board" means:

(a) The Kentucky Board of Certification of Wastewater System Operators; or

(b) The Kentucky Board of Certification of Water Treatment and Distribution System Operators.

(3) "Cabinet" is defined by KRS 224.01-010(9).

(4) "Certificate" means a certificate of competency issued by the cabinet stating that the operator has met the requirements for the specified operator classification as established by 401 KAR Chapter 11.

(5) "Certified operator" means an individual that holds an active certified operator's certificate issued in accordance with 401 KAR 11:050.

(6) "Core content" means the information identified as essential by the board for purposes of certification examination and continuing education training.

(7) "Direct responsible charge" means personal, first-hand responsibility to conduct or actively oversee and direct procedures and practices necessary to ensure that the drinking water treatment plant or distribution system is operated in accordance with accepted practices and with KRS Chapters 223 and 224 and 401 KAR Chapters 8 and 11.

(8) "Operator" means a person involved in the operation of a wastewater treatment plant, wastewater collection system, drinking water treatment plant, or drinking water distribution system.

(9) "Primary responsibility" means personal, first-hand responsibility to conduct or actively oversee and direct procedures and practices necessary to ensure that the wastewater treatment plant or wastewater collection system is operated in accordance with accepted practices and with KRS Chapter 224 and 401 KAR Chapters 5 and 11. (35 Ky.R. 473; Am. 1210; eff. 3-6-2009; 36 Ky.R. 449; 1047; eff. 2-5-2010.)

401 KAR 11:010. Boards of certification.

RELATES TO: KRS 223.160-220, 224.73-110, EO 2009-538

STATUTORY AUTHORITY: KRS 223.160-200, 224.10-100, 224.10-110, 224.73-110, EO 2009-538

NECESSITY, FUNCTION, AND CONFORMITY: KRS 224.10-110 authorizes the cabinet to promulgate administrative regulations concerning the board of certification of wastewater system operators and the certification of wastewater operators. KRS 223.160-220 authorizes the cabinet to promulgate administrative regulations concerning the board of certification for water treatment and distribution operators and the certification of water treatment and distribution system operators. EO 2009-538, effective June 12, 2009, establishes the new Energy and Environment Cabinet. This administrative regulation establishes the duties of the Kentucky Board of Certification of Wastewater System Operators and the Kentucky Board of Certification of Water Treatment and Distribution System Operators.

Section 1. Duties of the Board. The board shall:

(1) Evaluate the qualifications of applicants and recommend qualified applicants to the cabinet for certification examination;

(2) Review and provide comments to the cabinet on proposed administrative regulations regarding operator certification;

(3) Review and make recommendations to the cabinet on core content for certification examinations and continuing education training for certification renewal;

(4) Review and make recommendations to the cabinet on training proposed to provide continuing education to certified operators. During the evaluation of training courses and seminars, the board shall consider:

(a) The consistency of training material with the core content;

(b) The ability of the training to provide information that supports effective water conveyance, treatment, and quality; and

(c) The ability of the instructor to properly present the training;



- (5) Assist the cabinet in drafting examinations for the certification of operators;
- (6) Review and provide comments to the cabinet on proposed fees for the training and certification of operators;
- (7) Review applications for reciprocity and recommend to the cabinet the acceptance or denial of the application based on the criteria established in 401 KAR 11:050, Section 1(8); and
- (8) Review evidence and advise the cabinet regarding disciplinary actions for certified operators who fail to comply with KRS Chapters 223 and 224 or 401 KAR Chapter 5, 8, or 11. (35 Ky.R. 474; Am. 1211; 1746; eff. 3-6-2009; 36 Ky.R. 450; 1049; eff. 2-5-2010.)

401 KAR 11:020. Standards of professional conduct for certified operators.

RELATES TO: KRS 223.160-220, 224.73-110, EO 2009-538

STATUTORY AUTHORITY: KRS 224.10-100, 224.10-110, 224.73-110, EO 2009-538

NECESSITY, FUNCTION, AND CONFORMITY: KRS 224.10-110 authorizes the cabinet to promulgate administrative regulations concerning the certification of water and wastewater operators. EO 2009-538, effective June 12, 2009, establishes the new Energy and Environment Cabinet. This administrative regulation establishes standards for the performance of certified water and wastewater operator duties.

Section 1. Standards of Professional Conduct. (1) In order to safeguard the life, health, and welfare of the public and the environment and to establish and maintain a high standard of integrity in the certified operator profession, the following standards of professional conduct apply to persons certified in accordance with 401 KAR Chapter 11:

- (a) A certified operator shall, during the performance of operational duties, protect the safety, health, and welfare of the public and the environment;
- (b) A certified operator shall use reasonable care and judgment in the performance of operational duties;
- (c) If a certified operator's judgment is overruled by an employer under circumstances in which the safety, health, and welfare of the public or the environment are endangered, the certified operator shall inform the employer of the possible consequences;
- (d) A certified operator shall be objective, truthful, and complete in applications, reports, statements, and testimony provided to the cabinet; and
- (e) A certified operator shall ensure the integrity of the samples that the operator collects, prepares, or analyzes so that results shall be a true representation of water quality.

(2) Proof of certification. While on duty, a certified operator shall carry the cabinet-issued wallet card showing the operator's current certification status.

(3) Maintenance of records. If information related to the operator's employment or mailing address changes from that provided in the application for certification, the certified operator shall provide written notification to the cabinet within thirty (30) days. (35 Ky.R. 475; Am. 1212; 1747; eff. 3-6-2009; 36 Ky.R. 452; 1051; eff. 2-5-2010.)

401 KAR 11:040. Water treatment and distribution system operators; classification and qualifications.

RELATES TO: KRS 223.160-220, 224.10-100, 224.10-110, EO 2009-538

STATUTORY AUTHORITY: KRS 223.160-220, 224.10-100, 224.10-110, EO 2009-538

NECESSITY, FUNCTION, AND CONFORMITY: KRS 224.10-100 and 224.10-110 authorize the cabinet to promulgate administrative regulations concerning the certification of water operators. EO 2009-538, effective June 12, 2009, establishes the new Energy and Environment Cabinet. This administrative regulation establishes classification of water treatment and distribution operator certifications and establishes the qualifications for certification.

Section 1. Classification of Water Operator Certifications. (1) Water treatment certifications.

(a) Limited certification. As provided in KRS 223.160(2), an operator issued a limited certificate may have primary responsibility for a water treatment facility for a school and for a semipublic water supply.

(b) Class IA-D treatment certification.

1. A Class IA-D treatment operator may be in direct responsible charge for a Class IA-D or Class IB-D water treatment plant as established in 401 KAR 8:030, Section 2.

2. A Class IA-D treatment operator shall not be in direct responsible charge for a water treatment plant with a larger design capacity.

(c) Class IB-D treatment certification.

1. A Class IB-D treatment operator may be in direct responsible charge for a Class IB-D water treatment plant, as established in 401 KAR 8:030, Section 2.

2. A Class IB-D treatment operator shall not be in direct responsible charge for a water treatment plant with a larger design capacity.

(d) Class IIA treatment certification.

1. A Class IIA treatment operator may be in direct responsible charge for a Class IIA water treatment plant or a Subclass A or B water treatment plant of an equal to or smaller design capacity, as established in 401 KAR 8:030, Section 2.

2. A Class IIA treatment operator shall not be in direct responsible charge for a water treatment plant with a larger design capacity.

(e) Class IIB-D treatment certification.

1. A Class IIB-D treatment operator may be in direct responsible charge for a Class IIB-D water treatment plant or a Subclass B water treatment plant of a smaller design capacity, as established in 401 KAR 8:030, Section 2.

2. A Class IIB-D treatment operator shall not be in direct responsible charge for a water treatment plant with a larger design capacity.

(f) Class IIIA treatment certification.

1. A Class IIIA treatment operator may be in direct responsible charge for a Class IIIA water treatment plant or a Subclass A or B water treatment plant of an equal to or smaller design capacity, as established in 401 KAR 8:030, Section 2.

2. A Class IIIA treatment operator shall not be in direct responsible charge for a water treatment plant with a larger design capacity.

(g) Class IIIB treatment certification.

1. A Class IIIB treatment operator may be in direct responsible charge for a Class IIIB water treatment plant or a Subclass B water treatment plant of a smaller design capacity, as established in 401 KAR 8:030, Section 2.

2. A Class IIIB treatment operator shall not be in direct responsible charge for a water treatment plant with a larger design capacity.

(h) Class IVA treatment certification.

1. A Class IVA treatment operator may be in direct responsible charge of any Subclass A or B water treatment plant, as established in 401 KAR 8:030, Section 2.

(i) Class IVB treatment certification.

A Class IVB treatment operator may be in direct responsible charge of any Subclass B water treatment plant, as established in 401 KAR 8:030, Section 2.

(2) Water distribution certifications.

(a) Class ID distribution certification.

1. A Class ID distribution operator may be in direct responsible charge for a Class ID water distribution system, as established in 401 KAR 8:030, Section 2.

2. A Class ID distribution operator shall not be in direct responsible charge for a water distribution system serving a larger population.

(b) Class IID distribution certification.

1. A Class IID distribution operator may be in direct responsible charge for a Class IID water distribution system, as established in 401 KAR 8:030, Section 2.

2. A Class IID distribution operator shall not be in direct responsible charge for a water distribution system serving a larger population.

(c) Class IIID distribution certification.

1. A Class IIID distribution operator may be in direct responsible charge for a Class IIID water distribution system, as established in 401 KAR 8:030, Section 2.

2. A Class IIID distribution operator shall not be in direct responsible charge for a water distribution system serving a larger population.

(d) Class IVD distribution certification.

1. A Class IVD distribution operator may be in direct responsible charge of any water distribution system.

(3) Bottled water certification. A bottled water operator may be in direct responsible charge for a bottled water system that bottles water for sale.

(4) Operator in Training designations.

(a) Except as provided in paragraph (c) of this subsection, a certified operator with an Operator in Training designation shall not serve in direct responsible charge of a water treatment plant or distribution system.

(b) A certified operator with an Operator in Training designation shall work under the direct supervision of a certified operator who works at the same facility and has obtained a certification level that is equal to or greater than the certification level required to serve in direct responsible charge of the facility.

(c) If a certified operator also has been issued a water treatment, distribution, or bottled water certification without an Operator in Training designation, the operator may serve in direct responsible charge a water treatment plant, distribution system or bottled water system as provided by this Section for the certifications that do not have an Operator in Training designation.

Section 2. Water Operator Qualifications: Experience, Education, and Equivalencies. An individual desiring to become a certified operator shall meet the following minimum qualifications prior to the cabinet approving the individual to take a certification examination as established in 401 KAR 11:050.

(1) The education and experience requirement for each class of water treatment certifications shall be as follows:

(a) Limited certification:

1. Education. A minimum level of education shall not be required.

2. Experience. A minimum level of experience shall not be required.

(b) Class IA-D treatment certification:

1. Education. A high school diploma or general education development (GED) certificate shall be required; and

2. Experience. One (1) year of acceptable operation of a Subclass A public water system, as established in 401 KAR 8:030, Section 2, with any design capacity

(c) Class IB-D treatment certification:

1. Education. A high school diploma or general education development (GED) certificate shall be required; and

2. Experience. One (1) year of acceptable operation of a Subclass A or B public water system, as established in 401 KAR 8:030, Section 2, with any design capacity shall be required.

(d) Class IIA treatment certification:

1. Education. A high school diploma or general education development (GED) certificate shall be required; and

2. Experience. Two (2) years of acceptable operation of a water treatment plant, with six (6) months in a Class IIA, IIIA, or IVA water treatment plant, as established in 401 KAR 8:030, Section 2, shall be required.

(e) Class IIB-D treatment certification:

1. Education. A high school diploma or general education development (GED) certificate shall be required; and

2. Experience. Two (2) years of acceptable operation of a public water system with six (6) months in a Class IA-D, II B-D, or higher water treatment plan, as established in 401 KAR 8:030, Section 2, shall be required.

(f) Class IIIA treatment certification:

1. Education. A high school diploma or general education development (GED) certificate shall be required; and

2. Experience. Three (3) years of acceptable operation of a public water treatment plant with one (1) year in a Class IIA, IIIA, or IVA water treatment plant, as established in 401 KAR 8:030, Section 2, shall be required.

(g) Class IIIB treatment certification:

1. Education. A high school diploma or general education development (GED) certificate shall be required; and

2. Experience. Three (3) years of acceptable operation of a public water treatment plant with one (1) year in a Class IIA, IIB-D, IIIA, IIIB, IVA, or IVB water treatment plant, as established in 401 KAR 8:030, Section 2, shall be required.

(h) Class IVA treatment certification:

1. Education. A baccalaureate degree in engineering, science, or equivalent shall be required; and

2. Experience. One (1) year of acceptable operation of a Class IIIA or IVA public water treatment plant, as established in 401 KAR 8:030, Section 2, shall be required.

(i) Class IVB treatment certification:

1. Education. A baccalaureate degree in engineering, science, or equivalent shall be required; and

2. Experience. One (1) year of acceptable operation of a Class IIIA, IIIB, IVA, or IV public water treatment plant shall be required.

(2) The educational and experience qualifications for water distribution certifications shall be as follows:

(a) Class ID distribution certification:

1. Education. A high school diploma or general education development (GED) certificate shall be required; and

2. Experience. One (1) year of acceptable operation of a water distribution system shall be required.

(b) Class IID distribution certification:

1. Education. A high school diploma or general education development (GED) certificate shall be required; and

2. Experience. Two (2) years of acceptable operation of a water distribution system shall be required.

Six (6) months of the required experience shall be in a water distribution system serving a population greater than or equal to 1,500.

(c) Class IIID distribution certification:

1. Education. A high school diploma or general education development (GED) certificate shall be required; and

2. Experience. Three (3) years of acceptable operation of a water distribution system shall be required.

One (1) year of the required experience shall be in a water distribution system serving a population greater than or equal to 1,500.

(d) Class IVD distribution certification:

1. Education. A baccalaureate degree in engineering, science, or equivalent shall be required; and

2. Experience. One (1) year of acceptable operation of a water distribution system serving a population greater than or equal to 15,000 shall be required.

(3) Bottled water certification. The educational and experience qualifications for bottled water certifications shall be as follows:

(a) Education. A High school diploma or general education development (GED) certificate shall be required; and

(b) Experience. One (1) year of acceptable operation of a bottled water system shall be required.

(4) The educational and experience qualifications for Operator in Training designations shall be as follows:

(a) Class IA-D Treatment, Class IB-D Treatment, Class ID Distribution, and Bottled Water certifications.

1. Education. A high school diploma or general education development (GED) certificate shall be required; and

2. Experience. Experience shall not be required.

(b) All other applicants for the classifications identified in subsections 1(1) and 1(2) of this administrative regulation;

1. Shall have successfully qualified for and passed the certification exam of the same type classification at one (1) level lower than the Operator in Training designation being pursued; and

2. Shall not have been subject to disciplinary action as provided by 401 KAR 11:050, Section 4.

(5) Substitutions. The cabinet shall allow the following substitutions for the qualifications established in subsections (1), (2), and (3) of this section:

(a) Education in environmental engineering; environmental technology; and biological, physical, or chemical sciences shall be substituted if the substitution does not exceed fifty (50) percent of the required experience.

1. An associate degree shall be considered equivalent to two (2) years of experience.

2. A baccalaureate degree shall be considered equivalent to four (4) years of experience.

3. Education that did not result in a degree in a related field may be substituted for the required experience as follows:

a. Ten (10) contact hours, one (1) Continuing Education Unit, or one (1) post-secondary education quarter hour with a passing grade shall be considered equivalent to 0.022 years of experience.

b. One (1) postsecondary education semester hour with a passing grade shall be considered equivalent to 0.033 years of experience.

4. Education applied to the experience requirements specified in subsections (1) and (2) of this section shall not be applied to the education requirement.

(b) Experience may be substituted for the educational requirement as follows:

1. One (1) year of operational experience at a water system may substitute for one (1) year of education.

2. The cabinet may allow partial substitution of the education requirement by experience in maintenance, laboratory analysis, or other work related to the collection, treatment, or distribution of drinking water or wastewater. To establish how much experience shall be accepted, the cabinet shall determine the degree of technical knowledge needed to perform the work and the degree of responsibility the applicant had in the operation of the system.

3. Experience applied to the education requirement specified in subsections (1) and (2) of this section shall not be applied to the experience requirement.

(c) Water treatment and distribution experience may be substituted as follows:

1. Two (2) years of distribution system experience shall be considered equivalent to one (1) year of treatment experience.

2. One (1) year of treatment experience shall be considered equivalent to one (1) year of distribution system experience. (36 Ky.R. 1055; 1457; eff. 2-5-2010.)

401 KAR 11:050. Operator certification.

RELATES TO: KRS 223.160-220, 224.10-420(2), 224.73-110, EO 2009-538

STATUTORY AUTHORITY: KRS 223.160-220, 224.10-100, 224.10-110, 224.73-110, EO 2009-538

NECESSITY, FUNCTION, AND CONFORMITY: KRS 224.10-110 authorizes the cabinet to promulgate administrative regulations concerning the certification of water and wastewater operators. EO 2009-538, effective June 12, 2009, establishes the new Energy and Environment Cabinet. This administrative regulation establishes application and examination procedures; provisions relating to certificate issuance, renewal, and termination; reciprocity; training; and disciplinary actions.

Section 1. Application and Examination for Certification. (1) An individual desiring to become a certified operator shall first meet the qualifications established in 401 KAR 11:030 or 11:040 and then pass an examination administered by the cabinet.

(2)(a) An applicant for certification shall complete the Registration Form for Exams and Training and Education and Experience Documentation Form and shall submit them and the certification application fee to the cabinet.

(b) In addition to the requirements of paragraph (a) of this subsection, an applicant desiring to obtain an Operator in Training designation shall submit a signed letter for a certified operator located at the facility where the applicant will work. The letter shall include:

1. A statement from the certified operator indicating that the certified operator shall oversee the work of the applicant seeking an Operator in Training designation;
2. A commitment that the certified operator shall serve as a mentor to the applicant seeking an Operator in Training designation as long as the applicant is under the certified operator's direct responsible charge;
3. Verification that the certified operator is not currently the mentor for any other individuals with an Operator in Training designation; and
4. Confirmation that the certified operator has obtained a certification level that is equal to or greater than the certification level required to serve in primary responsibility of the facility.

(c) An application shall not be submitted to the cabinet unless the applicant has met the qualifications for examination.

(3)(a) After receipt of the application items established in subsection (2) of this section, the cabinet, considering the recommendation of the board, shall determine if the applicant meets the qualifications established in 401 KAR 11:030 or 11:040.

(b) If the applicant meets the qualifications, the cabinet shall approve the application and notify the applicant of the scheduled exam date.

(4)(a) Upon the applicant's completion of the examination, the cabinet shall notify the applicant of the applicant's examination score.

(b) A score of at least seventy (70) percent shall be required to pass the examination.



(5)(a) The cabinet shall issue a certificate and a wallet card to an applicant who successfully passes the certification examination.

(b) The certificate and wallet card shall designate the certification classification for which the operator has demonstrated competency.

(6) An applicant who fails to pass an examination may apply to take the examination again by resubmitting the Registration Form for Exams and Training and the application fee to the cabinet.

(7)(a) An examination shall not be returned to the applicant, but results may be reviewed by the applicant with a member of the cabinet.

(b) A request for a review shall be submitted to the cabinet in writing.

(8) A certificate shall be issued in a comparable classification, without examination, to a person who holds a valid certificate in a state, territory, or possession of the U.S. if:

(a) The requirements for certification under which the certificate was issued are not less stringent than the requirements for certification established in KRS 223.160-220, 224.73-110, and 401 KAR Chapter 11; and

(b) The applicant submits an Application for Reciprocity form and the reciprocity fee to the cabinet.

(9)(a) A certified operator who holds an Operator in Training designation may upgrade the certification by removing the Operator in Training Designation without examination if the operator:

1. Has satisfied the requirements of Section 3(1)(a) and (b) of this administrative regulation;

2. Has acquired the minimum experience required for the certification being pursued as required by 401 KAR 11:030 or 11:040; and

3. Submits a letter from the certified operator who has served as the applicant's mentor during the Operator in Training period that recommends the removal of the Operator in Training designation.

(b) A certified operator with an Operator in Training designation who is unable to comply with the requirements established in paragraph (a) of this subsection shall apply for and retake the certification exam to upgrade the operator's certification.

Section 2. Duration of Certification. (1)(a) Wastewater certifications shall expire on June 30 of an odd-numbered year unless suspended, revoked, or replaced by a higher classification certificate before that date.

(b) Wastewater certifications issued on or after January 1 and on or before June 30 of an odd-numbered year shall expire on June 30 of the next odd-numbered year.

(2)(a) Water certifications shall expire on June 30 of an even-numbered year unless suspended, revoked, or replaced by a higher classification certificate before that date.

(b) Water certifications issued on or after January 1 and on or before June 30 of an

even-numbered year shall expire on June 30 of the next even-numbered year.

(3)(a) An expired certification shall continue in force pending the administrative processing of a renewal if the certified operator has complied with the renewal requirements of Section 3 of this administrative regulation.

(b) A certification continued in accordance with this subsection shall remain fully effective and enforceable.

(4) A certification shall terminate if not renewed on or before December 31 of the year the certification expired.

Section 3. Continuing Education and Certification Renewal. (1) A certified operator who is not designated an Operator in Training may renew a certification without examination if the operator has:

(a) Accumulated the training hours required in subsection (5) of this section; and

(b) Submitted a completed Application for Certification Renewal form and the renewal fee to the cabinet or has renewed the certification electronically on the cabinet's Web site.

(2)(a) A certified operator seeking to renew a certification with an Operator in Training designation shall apply for and retake the certification exam as provided in Section 1 of this administrative regulation.

(b) The cabinet shall not approve an operator to take an exam to renew a certification with Operator in Training designation unless the applicant has accumulated the training hours required in subsection (5) of this section.

(3) If the Application for Certification Renewal form and the renewal fee are not received by the cabinet or submitted electronically by June 30 of the year the certification expires, a late renewal fee as established in 401 KAR 8:050, Section 3 or 11:060, Section 1 shall be paid.

(4)(a) A terminated certification shall not be renewed.

(b) An operator whose certification is terminated and who wishes to become recertified shall reapply for and pass an examination in accordance with Section 1 of this administrative regulation.

(5)(a) Prior to applying for certification renewal, a certified operator shall complete the required number of cabinet-approved training hours.

(b) A certified operator holding multiple wastewater certifications issued in accordance with this administrative regulation shall complete the required number of cabinet-approved training hours for the highest certificate held in lieu of completing the required number of continuing education hours required for each certificate.

(c) A certified operator holding multiple water certifications issued in accordance with this administrative regulation shall complete the required number of cabinet-approved training hours for the highest certificate held in lieu of completing the required number of

continuing education hours required for each certificate.

(d) Hours earned prior to initial certification shall not count toward certification renewal.

(e) Wastewater training hours shall expire two (2) years from the date earned.

(f) Water training hours shall be completed for each renewal during the two (2) year period immediately prior to the certificate expiration date.

1. Certified operators with a Bottled Water, Limited, Class I or II Treatment, Collection, or Distribution certification shall complete twelve (12) hours of approved training; or

2. Certified operators with a Class III or IV Treatment, Collection, or Distribution certification shall complete twenty-four (24) hours of approved training.

(6)(a) A training provider seeking approval of certified operator training shall submit to the cabinet a completed Application for Approval of Courses for Continuing Education Credit form.

(b) Upon completion of the approved training, the provider shall submit to the cabinet a completed Continuing Education Activity Report form.

(c) A certified operator who has attended training that has not been submitted to the cabinet for approval may apply for training approval as established in paragraph (a) of this subsection.

(d) A certified operator who provides approved training shall receive hour-for-hour credit for actual instruction time.

(7)(a) Cabinet approval of training shall expire two (2) years following the date of approval.

(b) The cabinet, in consultation with the board, shall extend the approval expiration date if:

1. The provider requests the extension in writing; and
2. The training has not changed from the previous approval.

Section 4. Disciplinary Action. (1) A certified operator shall be subject to disciplinary action if the cabinet, in consultation with the board, determines that the certified operator has not satisfactorily performed the operator's duties in accordance with 401 KAR 11:020.

(2)(a) A written complaint received by the board or cabinet regarding a certified operator, unless duplicitous or frivolous, and violations of 401 KAR 11:020 that are identified by the cabinet shall be evaluated by the board.

(b) The certified operator shall appear before the board if requested by the board

(3) The board shall make a recommendation to the cabinet regarding disciplinary action. The board may recommend that disciplinary action not taken or recommend that a disciplinary action be taken if the board determines that the certified operator has not satisfactorily performed operator duties in compliance with 401 KAR 11:020.

(4)(a) Upon receiving a recommendation from the board, the cabinet shall review the available evidence.

(b) After completing the review, the cabinet shall initiate the recommended disciplinary action or notify the board as to why an alternative disciplinary action was taken.

(5) A disciplinary action shall be commensurate with the severity, duration, and number of the violations. Disciplinary actions may include:

(a) Probation of the operator's certification for a specified period of time, not to exceed one (1) year;

(b) Suspension of the operator's certification for a specified period of time, not to exceed four (4) years, during which the certification shall be considered void;

(c) Revocation of the operator's certification;

(d) Civil or criminal penalties; or

(e) A combination of the disciplinary actions established in paragraphs (a) through (d) of this subsection.

(6) If disciplinary action is taken, the cabinet shall notify the certified operator and the operator's employer by certified mail of the action, the reasons outlined for the action, and the length of time for which the disciplinary action shall apply.

(7)(a) A certified operator whose certification has been suspended shall not have primary responsibility during the period that the suspension remains in effect.

(b) Experience gained during a suspension shall not be included toward meeting the requirements of 401 KAR 11:030 or 11:040.

(8) If a certification is revoked, the operator shall be ineligible for future certification.

(9) A certified operator who is aggrieved by a disciplinary action may file a petition for hearing with the cabinet pursuant to KRS 224.10-420(2).

Section 5. Incorporation by Reference. (1) The following material is incorporated by reference:

(a) "Registration Form for Exams and Training", August 2009;

(b) "Education and Experience Documentation Form", July 2009;

(c) "Application for Certification Renewal", August 2009;

(d) "Application for Approval of Courses for Continuing Education Credit", August 2009;

(e) "Continuing Education Activity Report", August 2009; and

(f) "Application for Reciprocity", July 2009.

(2) This material may be inspected, copied, or obtained, subject to applicable copyright law, at the Division of Compliance Assistance, 300 Fair Oaks Lane, Frankfort, Kentucky 40601, Monday through Friday, 8 a.m. to 4:30 p.m. (35 Ky.R. 479; Am. 1216; eff. 3-6-2009; eff. 2-5-2010.)

401 KAR 8:050. Drinking water program fees.

RELATES TO: KRS 223.220, 224.10-100, 224.10-110, 40 C.F.R. 142.10, Pub. L. 104-182, EO 2008-507, 2008-531

STATUTORY AUTHORITY: KRS 223.220, 224.10-100(20), 224.10-110

NECESSITY, FUNCTION, AND CONFORMITY: KRS Chapter 224.10-100(20) authorizes the cabinet to establish, by administrative regulation, a fee or schedule of fees for the cost of processing applications for permits authorized by KRS Chapter 224. EO 2008-507 and 2008-531, effective June 16, 2008, abolish the Environmental and Public Protection Cabinet and establish the new Energy and Environment Cabinet. This administrative regulation establishes fees for reviewing plans and specifications of public water systems, for operator certification, and for laboratory certification.

Section 3. (1) Fees for certification of water treatment plant and water distribution system operators.

(a) Certification application fee shall be \$100.

(b) A renewal application fee shall be:

1. Fifty (50) dollars if renewed through the cabinet Web site; or
2. \$100 if not renewed through the cabinet Web site.

(c) A renewal late fee shall be \$250.

(d) A reciprocity fee shall be \$500.

(2) Each year the cabinet, in consultation with the board, shall establish fees for operator training conducted by the cabinet.

(3)(a) The fees established in subsection (1) of this section shall be nonrefundable.

(b) Fifty (50) percent of the fees established in subsection (2) of this section shall be refundable if registration is canceled at least two (2) business days prior to the beginning of the training event.

(c) The fees in subsection (2) of this section shall be fully refunded if the training event is cancelled by the cabinet. (17 Ky.R. 599; eff. 11-15-1990; 35 Ky.R. 1847; eff. 7-6-2009.)

This page left blank intentionally.

# REFERENCES

Drinking Water Glossary – USEPA Ground Water and Drinking Water

Water Treatment Plant Operation. California State University, Sacramento, School of Engineering, Applied Research and Design Center. 1988

Surface Water Treatment: The New Rules. Harry von Huben. American Water Works Association 1991

Safe Drinking Water Act Amendments, Regulations and Standards. EJ Calabrese: CE Gilbert: and H. Pastides 1988

Water Resources Planning. A. A. Dzurik 1990