



44TH TURBOMACHINERY & 31ST PUMP SYMPOSIA
HOUSTON, TEXAS | SEPTEMBER 14 – 17 2015
GEORGE R. BROWN CONVENTION CENTER

500 centrifugal pump failures prevented using new prevention strategy

Bladimir Gomez
Supervisor,
Rotating Equipment Engineering
PDVSA CRP Refinery



PDVSA



Bladimir Gómez, MBA, ME - Bladimir is the Superintendent of Rotating Equipment Engineering at the PDVSA CRP Refinery Complex with 12 years of experience providing expertise for all rotating equipment from new specifications, to troubleshooting, and repair strategies.

Bladimir has a Mechanical Engineer degree and an MBA with focus on management of quality and productivity from Francisco de Miranda University, Venezuela.

The Problem

In a major refinery there was excessive failures of centrifugal pumps, that cost the company millions of dollars every year.

A new failure prevention strategy was developed to reduce the high cost of failures.

Centrifugal Pumps Failures and Repair Costs for 2011-2012

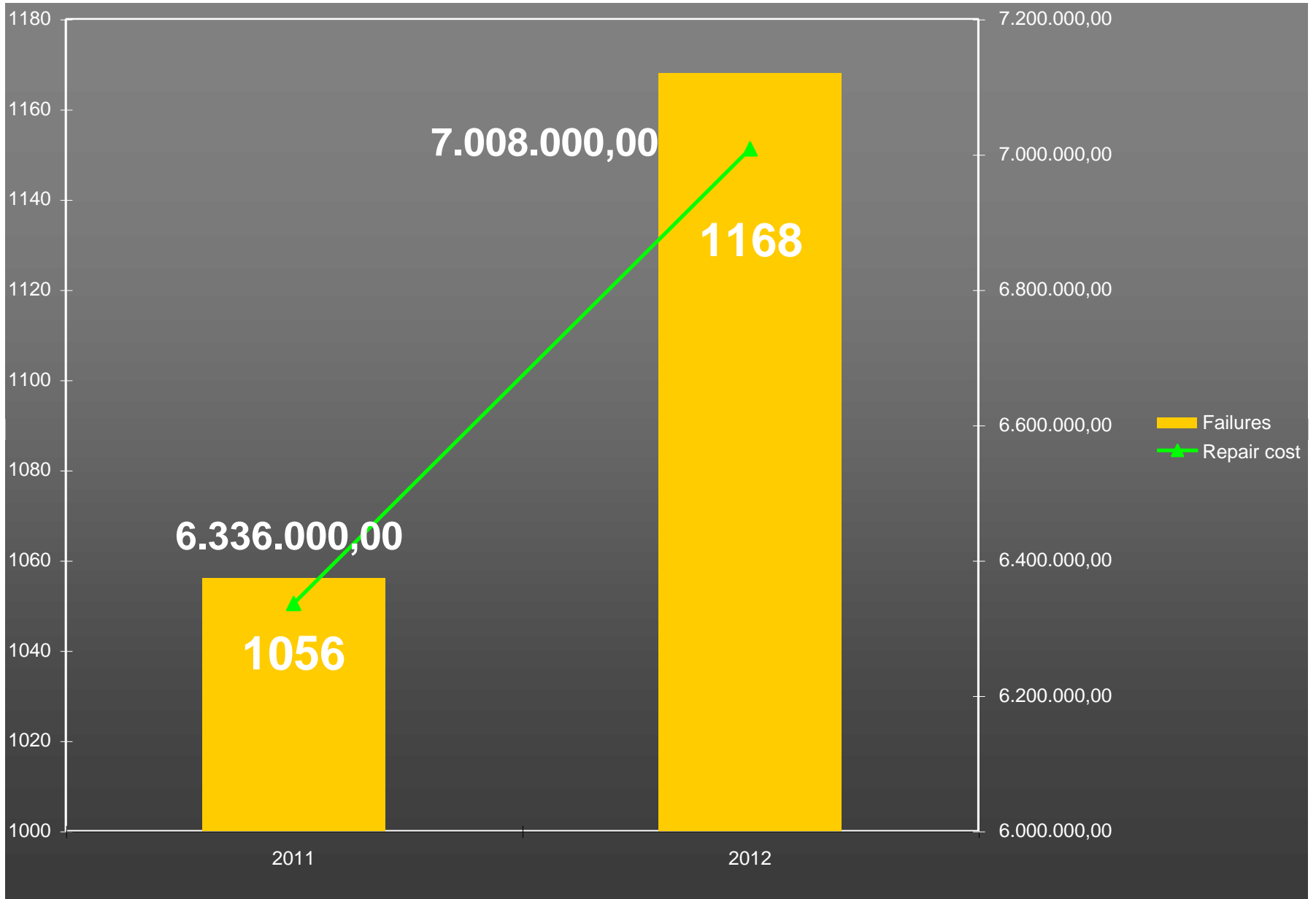

Centrifugal Pumps Failure by Component

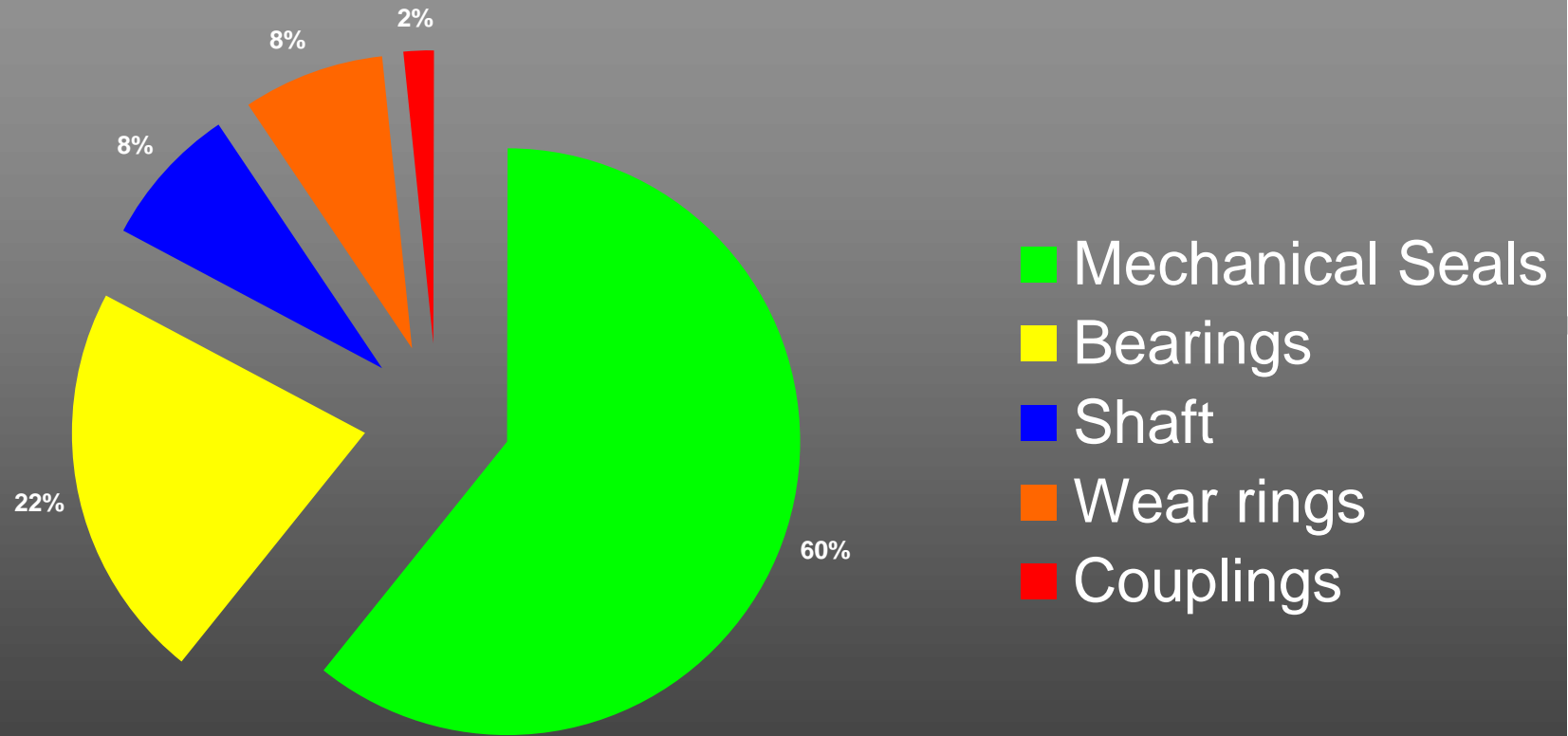

Centrifugal Pump Failure Causes

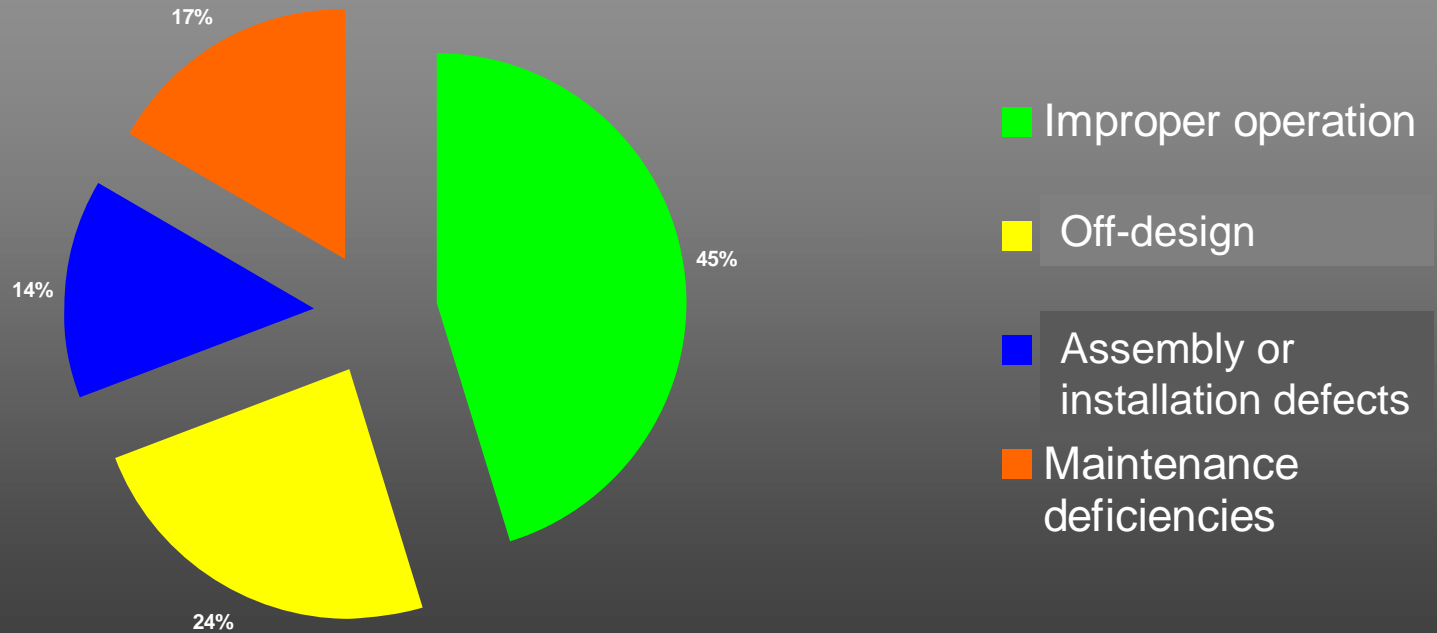

ELEMENTS OF THE NEW STRATEGY (The Solution)

- **A New Definition of Failure**
- **Use of Failure Progression Model**
- **Development of Three Levels of Inspections**

Traditional Definition of Failure

The traditional definition of failure is the point of Functional Failure.

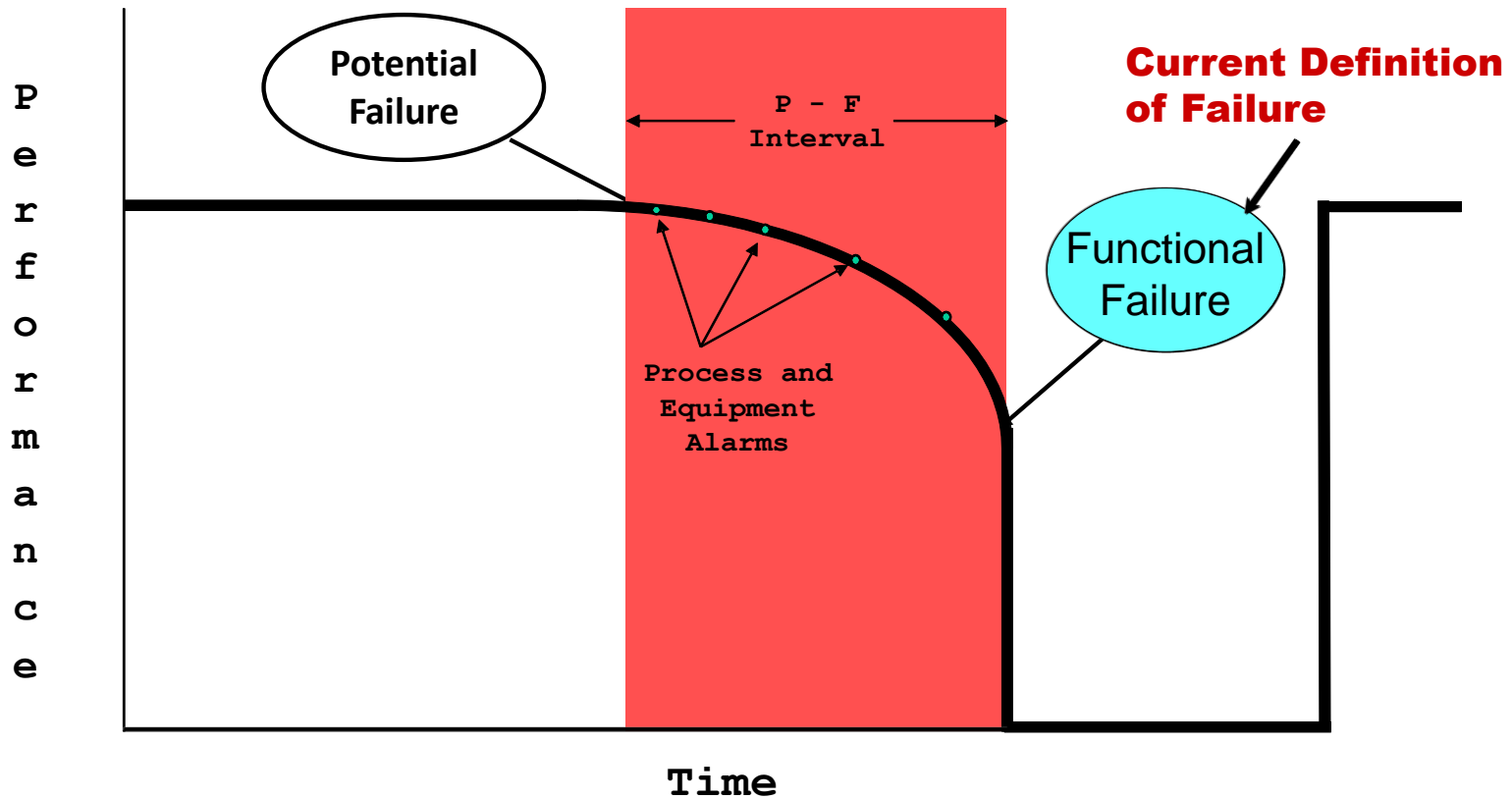

The oil and gas industry defines failure using the Potential-Functional (P-F) Failure Curve. The notion is that a piece of equipment, at some point in time, will begin to exhibit decreased performance. This is labeled the Potential Failure. If allowed to progress, the performance will continue to decrease until the point of Functional Failure.

New Definition of Failure

The new definition of failure is the point of Potential Failure.

**New Definition
of Failure**

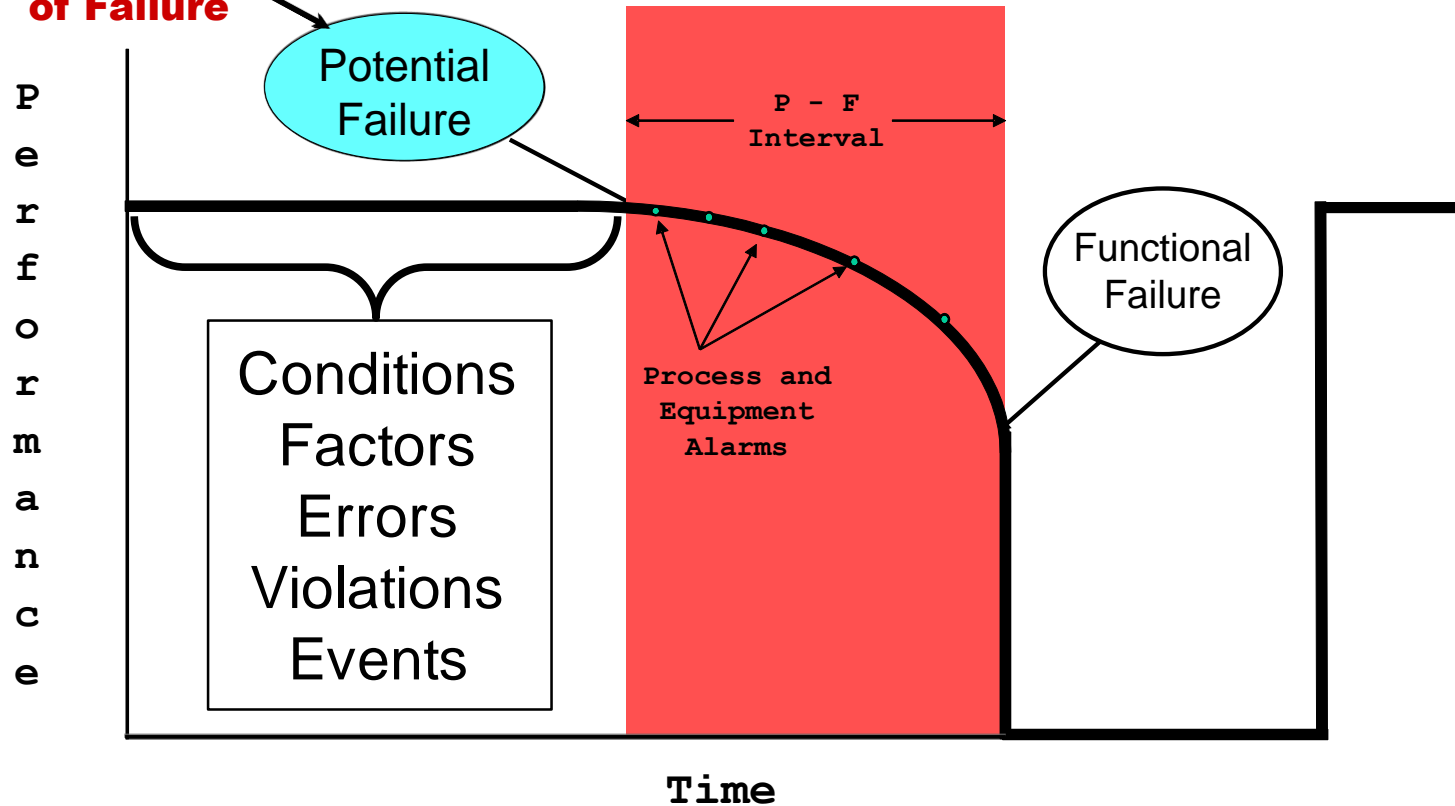

This is a paradigm shift in thinking and creates an entirely new approach to preventing failures. We designed inspection programs to identify the Conditions, Factors, Errors, and Violations which cause the Events that lead to the Potential Failures.

The Failure Progression Model

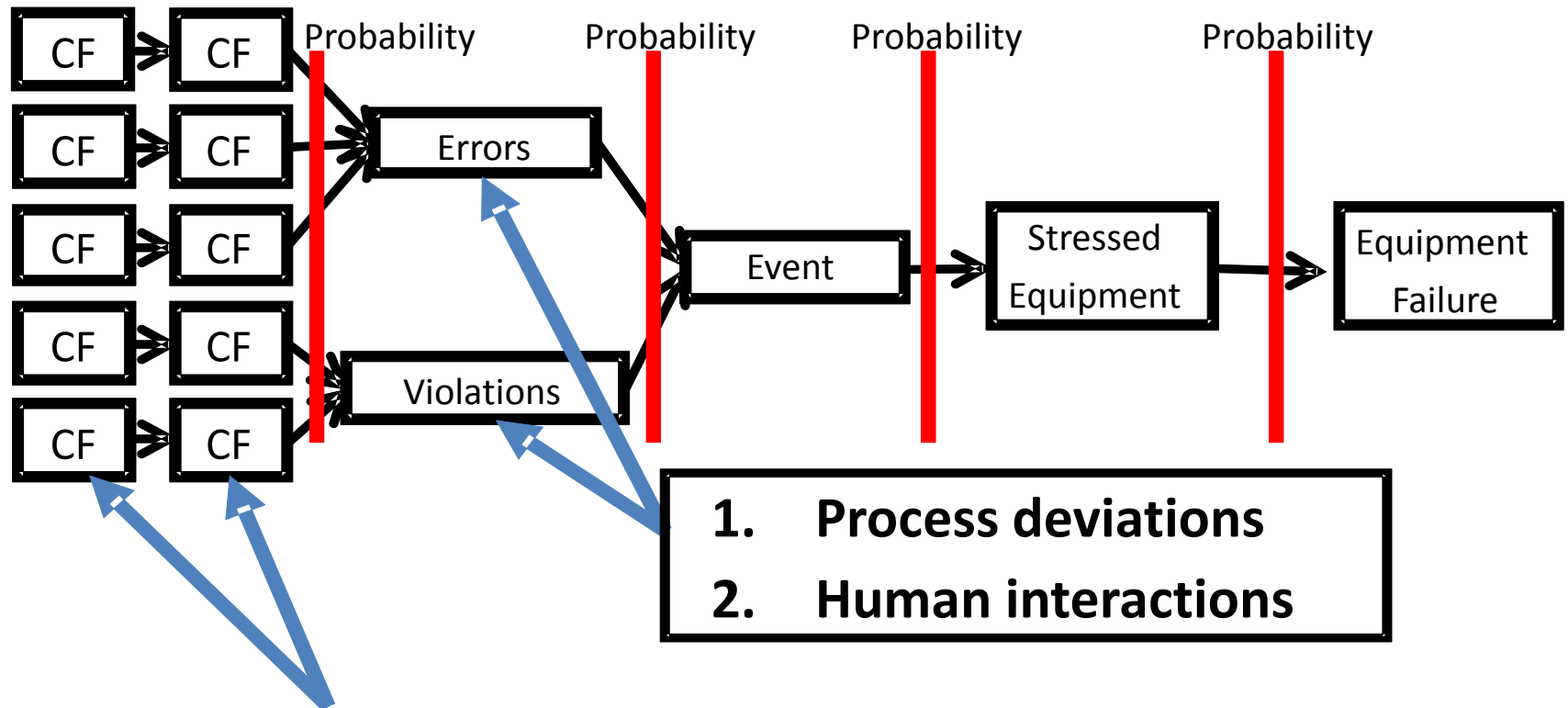

Contributing Factors that Influence Human Performance

The Top Twelve Contributing Factors

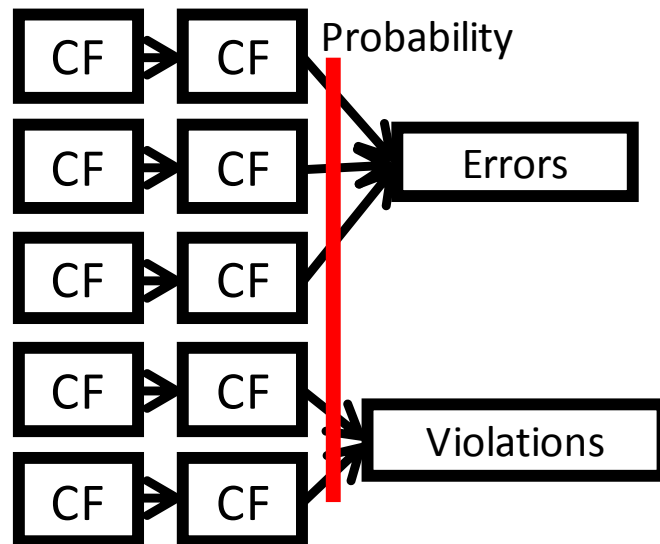

The Dirty Dozen

1. Miscommunication
2. Complacency
3. Distraction
4. Pressure
5. Resource Allocation
6. Lack of knowledge
7. Lack of awareness
8. Stress
9. Fatigue
10. Lack of assertiveness
11. Lack of teamwork
12. Norms [normalization of deviance]

PREVENT FAILURES

```
graph TD; A[PREVENT FAILURES] --- B[Behavior Management]; A --- C[Process Management]; A --- D[Asset Management]; B --> E[Level III Behavior Inspections]; C --> F[Level II Process Inspections]; D --> G[Level I Equipment Inspections];
```

Behavior
Management



Level III
Behavior
Inspections

Process
Management



Level II
Process
Inspections

Asset
Management



Level I
Equipment
Inspections

Three Levels of Inspections

Level III
Behavior
Inspections

Level II
Process
Inspections

Level I
Equipment
Inspections

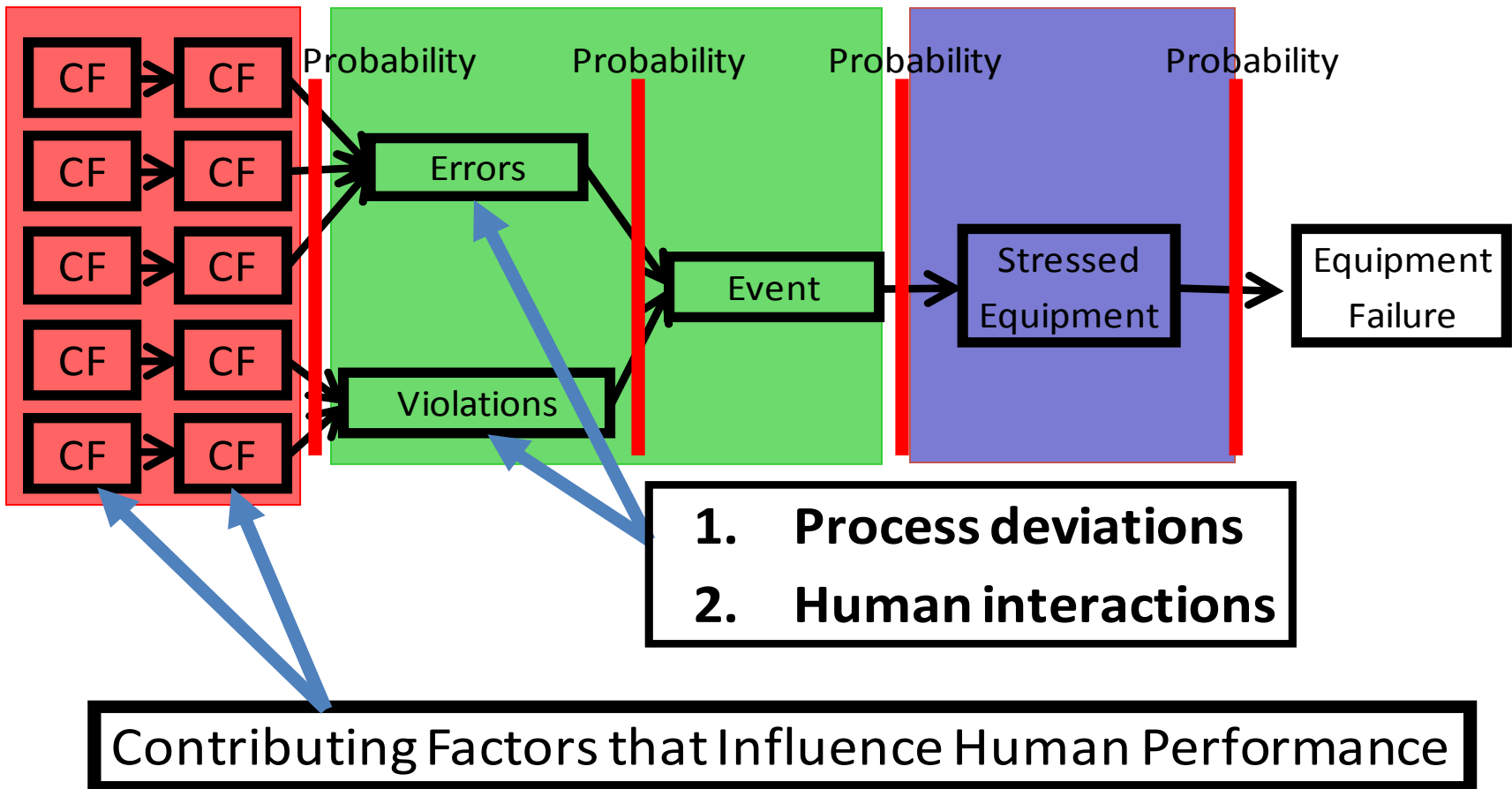

Strategies Comparison (Before and After)

Traditional Predictive Inspection	New failure Prevention Method
Defined routes focus on detection of failures (stressed equipment)	Defined routes focus on stressed equipments, process events(*) and human error and/or violations
Report Anomalies	Report preventions
Activity done by the Predictive Inspector	Activity done by the unit team (Inspector, Engineers, Operators and PM personnel)
Use of conventional hardware, such as vibration portable data collectors, infrared thermometers, process monitoring and instrumentation systems.	Use of conventional hardware, such as vibration portable data collectors, infrared thermometers, process monitoring and instrumentation systems.

Example: Mechanical seal failure prevention on a BB2 type centrifugal pump of a Cat Cracker Unit

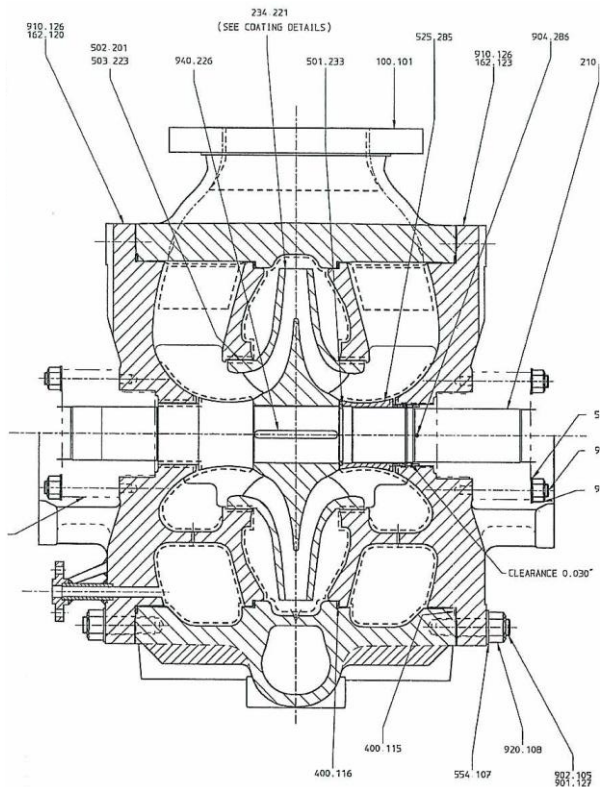

API Pump type BB2

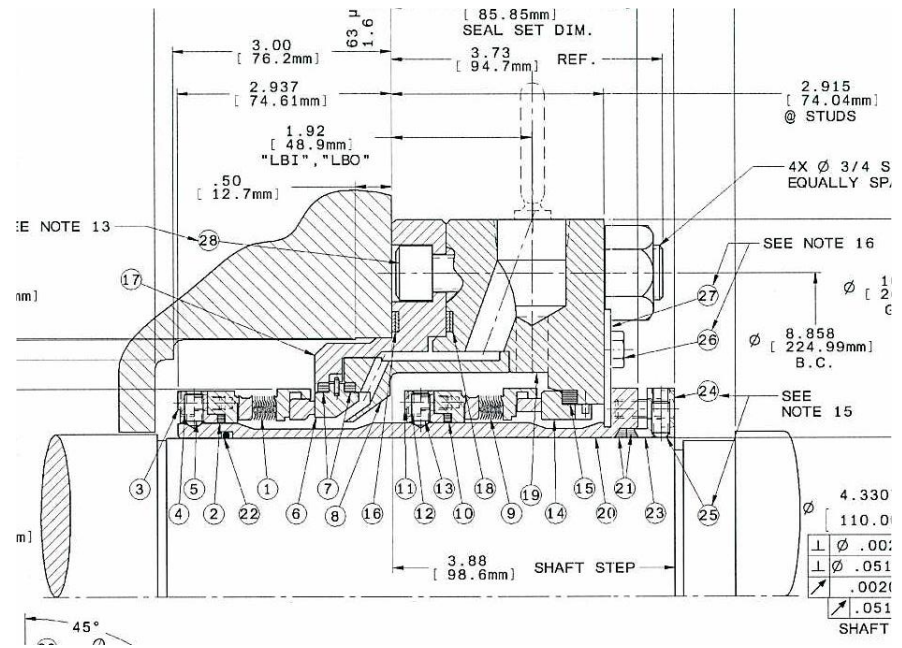

API Seal Code C2A3C54

API Plan 54 Diagram

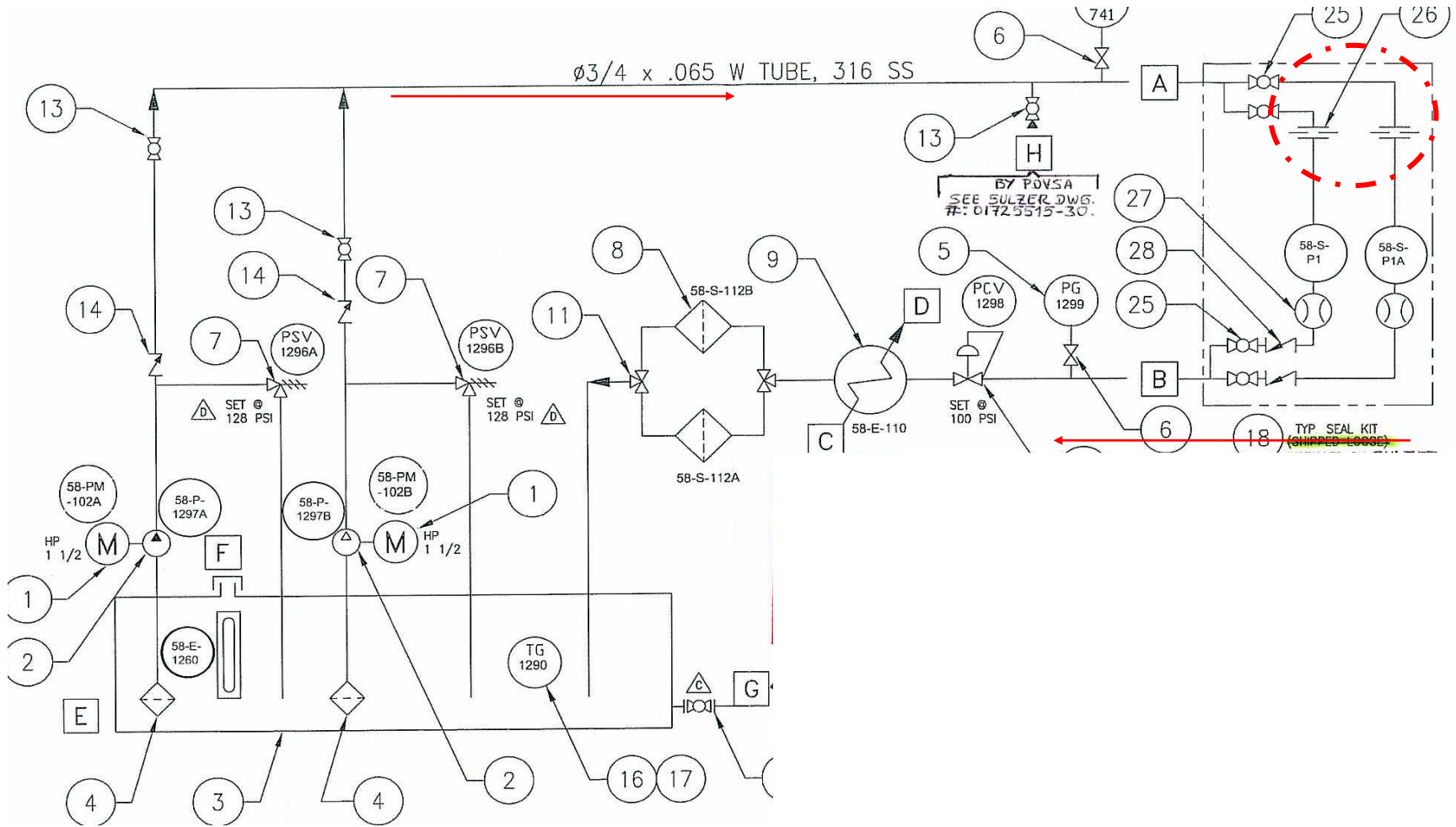

Inspection strategy:

Level 1 Inspections (Asset Management)

Vibration monitoring – Rotating equipment inspector

Inspection strategy:

Level 2 Inspection (Process Management)

Seal gland temperature – Plant Operator

Oil temperature / outlet API Plan – Plant Operator

Reservoir pressure – Plant Operator

Inspection strategy:

Level 3 Inspections (Behavior Management)

Contributing factors – Rotating equipment engineer

Mechanical Seal Conditions- API Plan 54- Level 2 Inspection

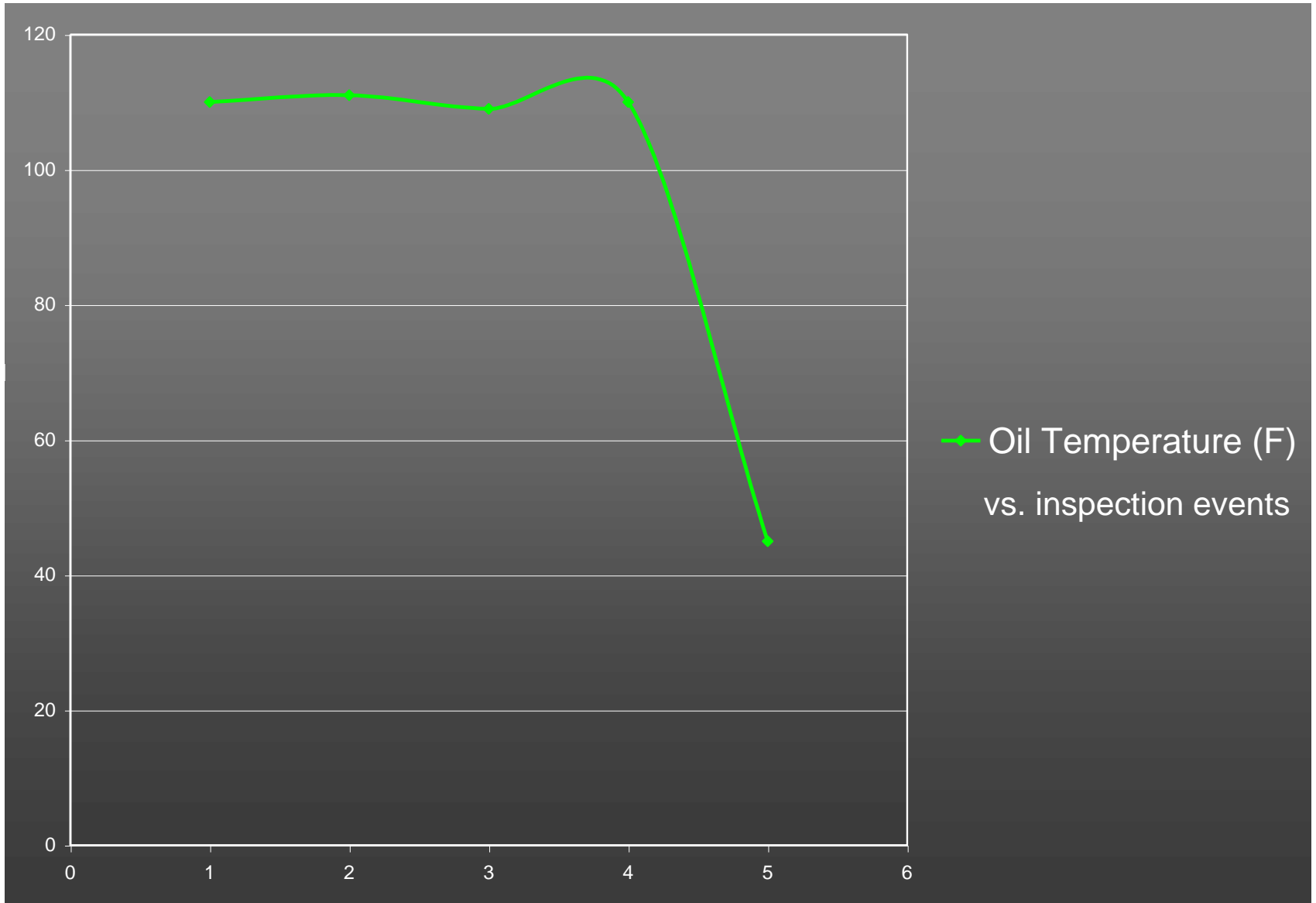

Mechanical Seal Conditions- API Plan 54- Level 2 Inspection

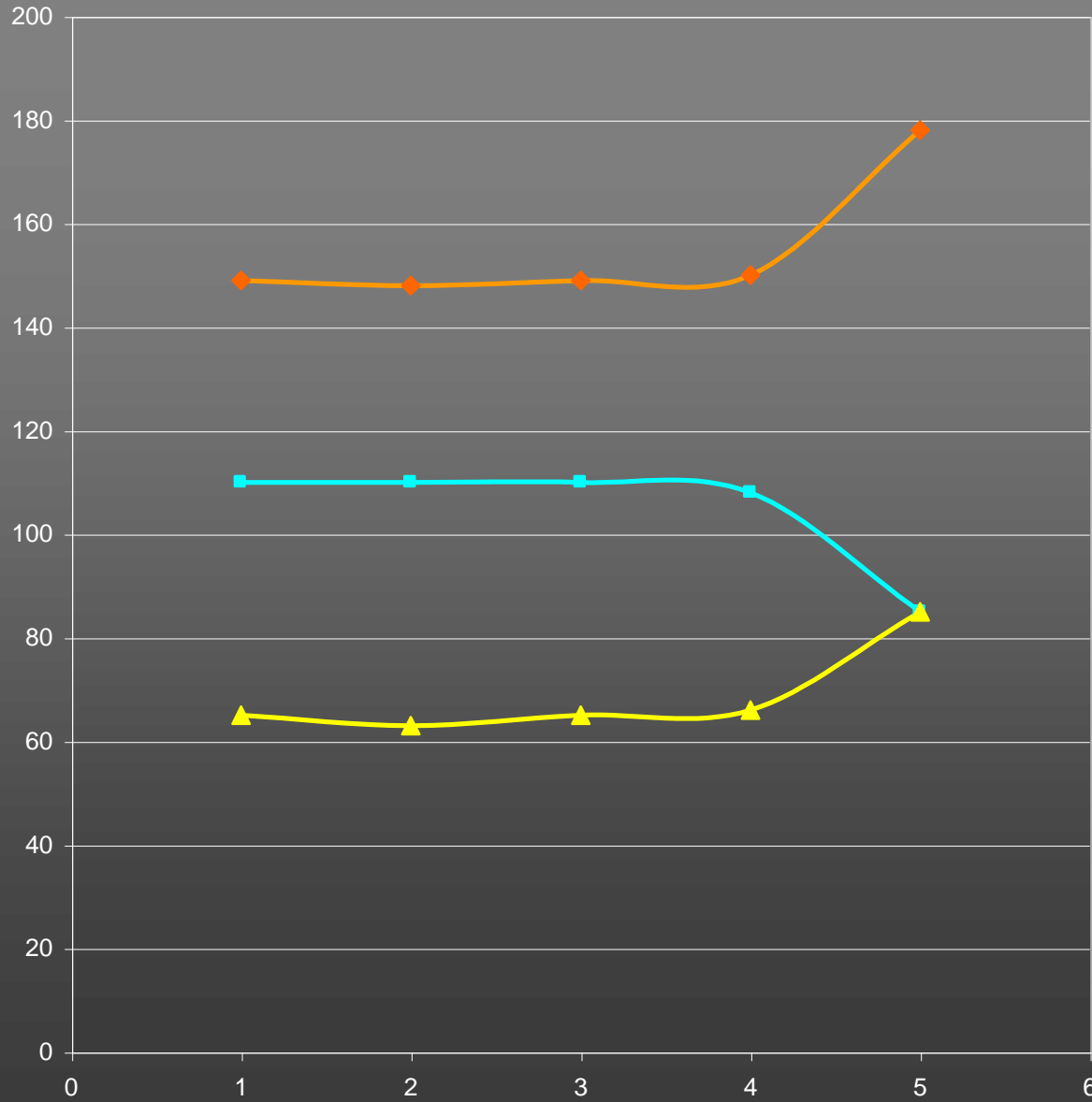

- ◆— Gland temperature
- Oil Outlet temperature
- ▲— Oil Inlet temperature

Each vs. inspection events

Inspection Results:

Level 1 inspections analysis: Vibration levels normal, no leaks at seal.

Level 2 Inspections analysis :Oil flow reduction across the system caused by problems with the flow regulation valve, determined by the level 2 inspections (IOW)

Level 3 inspection analysis : Miscommunication

Actions Following Inspections

Risk assesment: High

The monitoring of the flow regulation valve was not included in the existing Preventive Maintenance Program.

Actions:

- Replace flow regulation valve, include valve monitoring in the PM program and communicate to the personnel (training).
- Review of the rest of the API Plan 54 applications at the plant and check for the flow regulation valve monitoring.

Mechanical Seal Conditions- API Plan 54- Level 2 Inspection

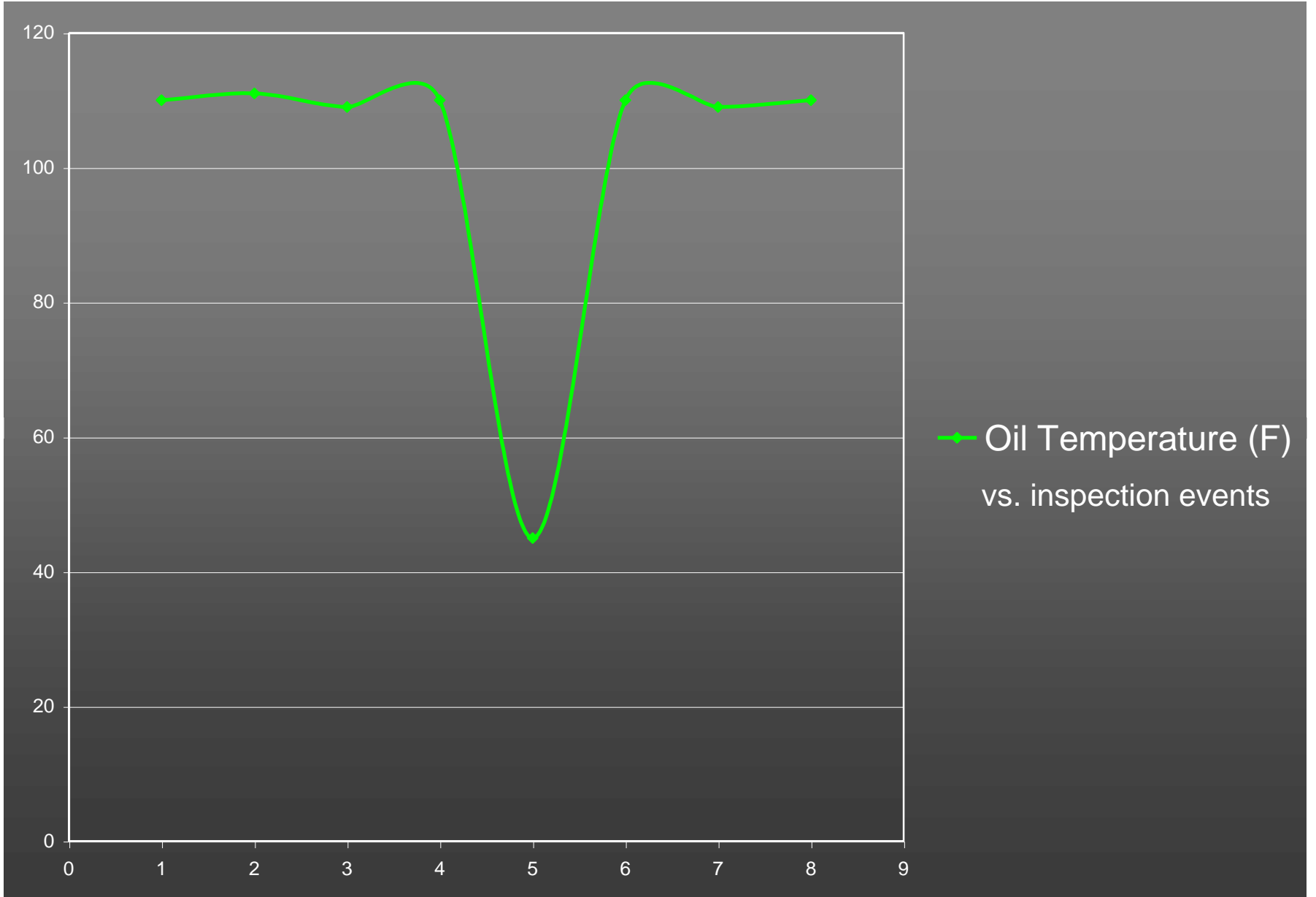

Mechanical Seal Conditions- API Plan 54- Level 2 Inspection

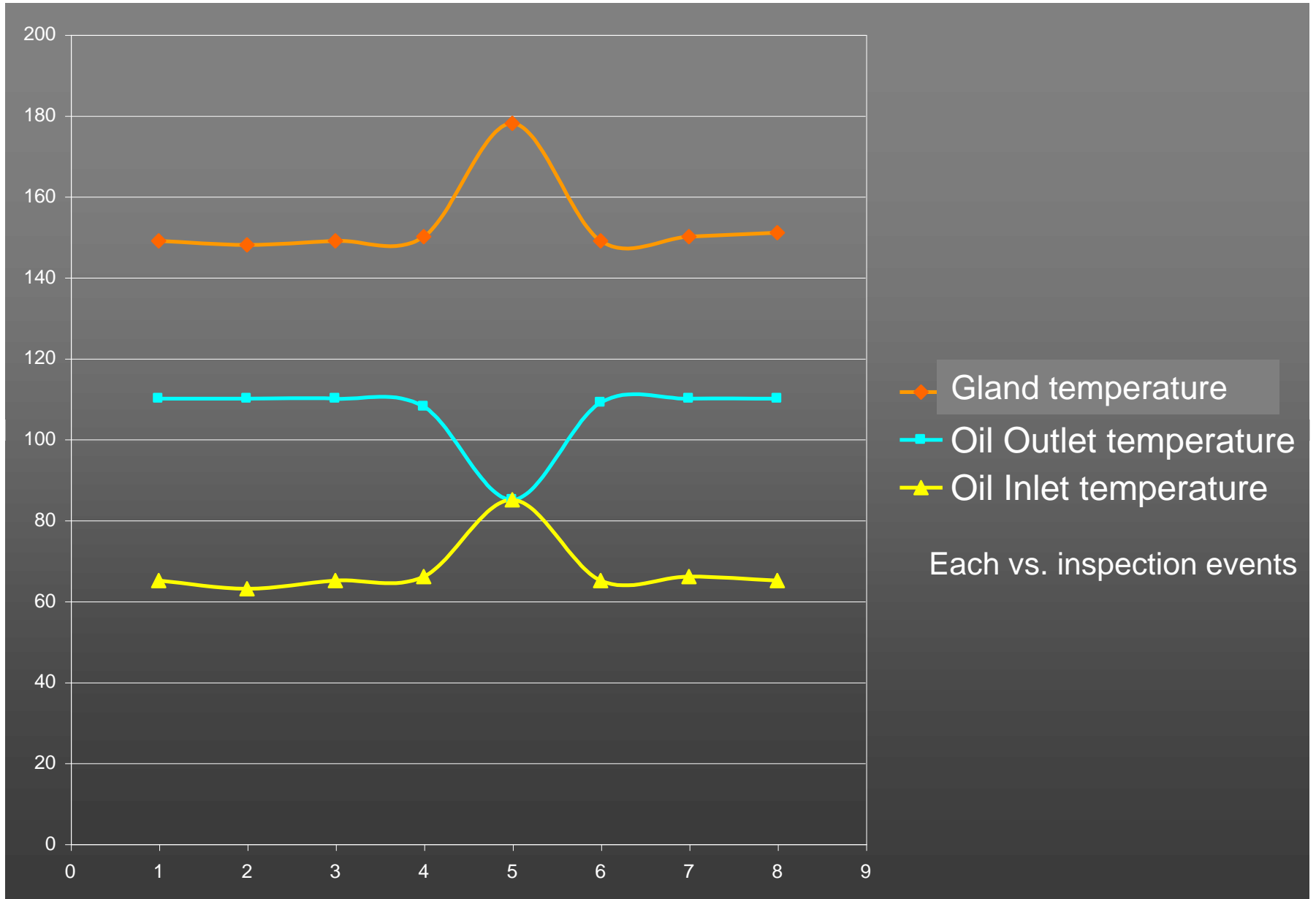

Conclusion:

By expanding the inspections to the process conditions and contributing factors that occur prior to the potential failure, the equipment failure is prevented.

The three levels of inspection were applied to 4000+ centrifugal pumps in the refinery.

This resulted in a reduction of over 500 pump failures over two years of implementation, with savings of 4MM\$.

No additional cost or resources were required.

To prevent failures, must reduce the contributing factors

Centrifugal Pumps Failures and Repair Costs for 2011-2014

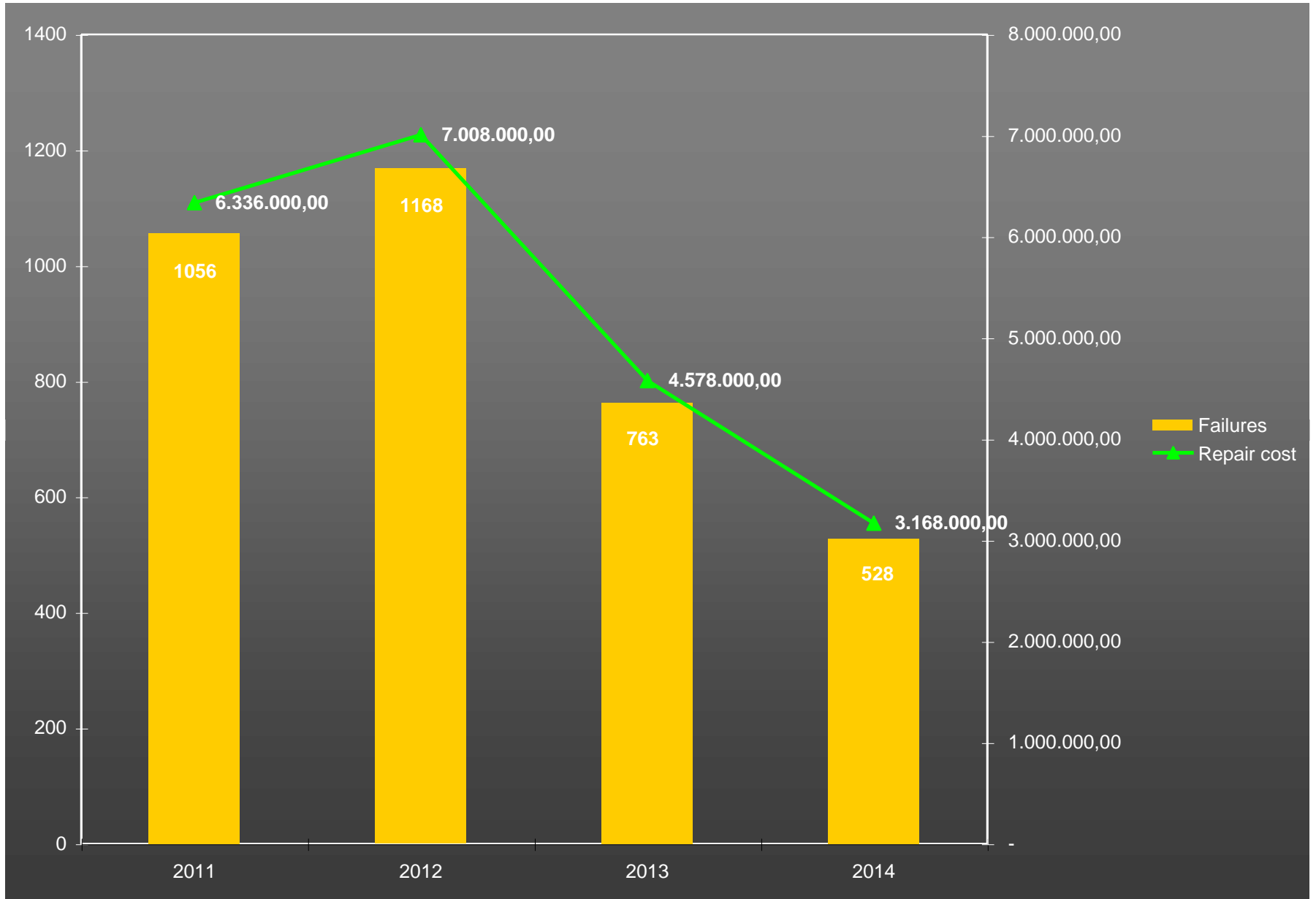

MTBF Centrifugal Pumps 2011-2015

MTBF Centrifugal Pumps

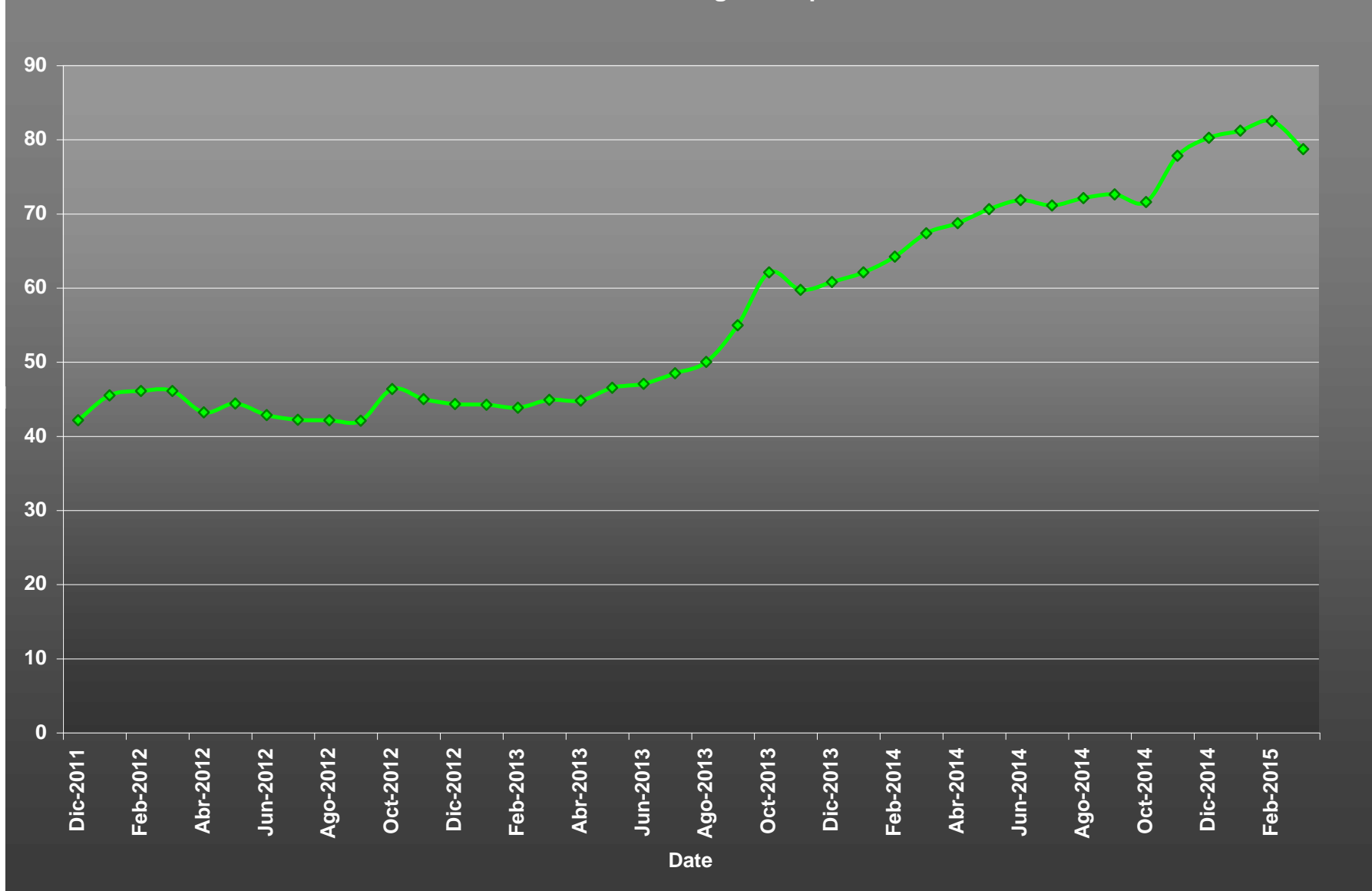

To prevent failures, one must reduce the contributing factors.