

Design aspects of drinking water treatment plants

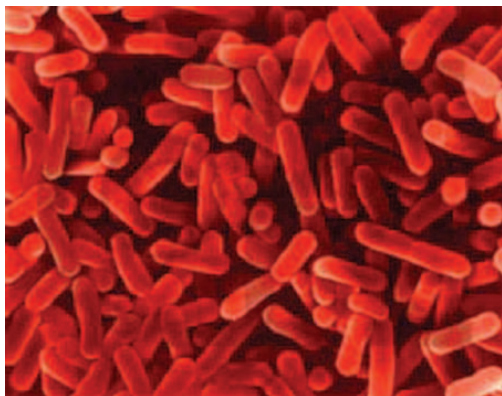
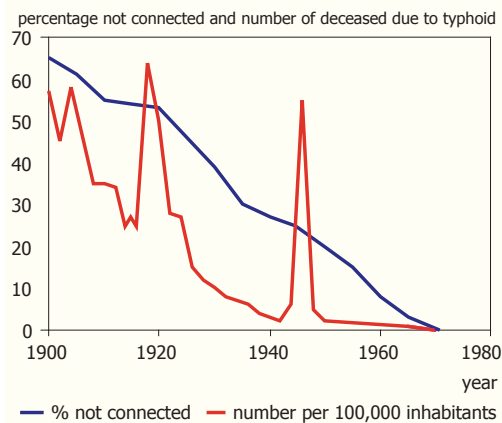

Contents

1. The technical setup of drinking water supply
2. Drinking water resources
3. Production
 - 3.1 Groundwater
 - 3.2 Surface water
 - 3.2.1 Surface water using direct treatment
 - 3.2.2 Surface water using soil aquifer recharge
4. Transport and Distribution
 - 4.1 Transport
 - 4.2 Storage
 - 4.3 Distribution network
 - 4.4 Drinking water installations
5. Planning process for public water supply
 - 5.1 Identification
 - 5.2 Definition
 - 5.3 Design
 - 5.4 Contract
 - 5.5 Construction, start-up and operation
 - 5.6 Laws, permits and standards
6. Costs
 - 6.1 Investment costs
 - Definition
 - Investment costs and capacity
 - 6.2 Operational (exploitation) costs
 - Definition
 - Structure
7. The practice of designing (Heel example)
 - 7.1 Preliminary studies
 - 7.2 Block diagram, site layout plan and sketch design
 - 7.3 Preliminary design
 - 7.4 Final design and detailed design
 - 7.5 Construction and start-up

This handout is based on *Drinking Water, Principles and Practices* by de Moel et al.

1. The technical setup of drinking water supply

The public water supply played an important role in the development of our modern society. The supply of good and reliable (i.e., safe) drinking water, since about 1850, has caused public health in Western Europe and North America to drastically improve. The public drinking water supply is important for economic development as well. Because of the supply of good and inexpensive water, any economic development is less tied to the direct surroundings. Therefore industries and companies can flourish more easily.

The public drinking water supply typically has a technical setup, as shown in Figure 1.

Production consists of the abstraction of raw water (either groundwater from the soil or surface water from rivers, canals and lakes) followed by treatment, in order to obtain drinking water quality. When production is located remote from the supply area, the water is first transported via pumps and pipes.

To reduce the daily variation in the water demand, distribution reservoirs are used. From these reservoirs, the drinking water is pressurized for distribution to the supply area using distribution pumps.

In the supply area, there is a distribution network available (a system of larger and smaller pipes), transporting water to customers. In some cases, water towers are used in the distribution networks in order to lessen pressure fluctuations.

A customer typically has a home connection to the distribution network (including a water meter), that distributes drinking water to the different taps in and around the house (bath, toilet, kitchen, washing machine, garden, etc.).

The quality of drinking water should comply with legal standards. In the Netherlands, the drinking water supply is regulated by the Water Supply Act and the specific quality standards are elaborated in the Decree on the Water Supply.

The Dutch legislation is stricter than the general European one. Internationally, there is much reference to the directives from the World Health Organization (WHO).

The technical installations and the operation of a drinking water production plant are primarily determined by the microbiological parameters. This is because the concentration of bacteria in source waters might be between 10,000 to 1,000,000,000 times higher than the maximum acceptable value in drinking water. Therefore, even a small con-

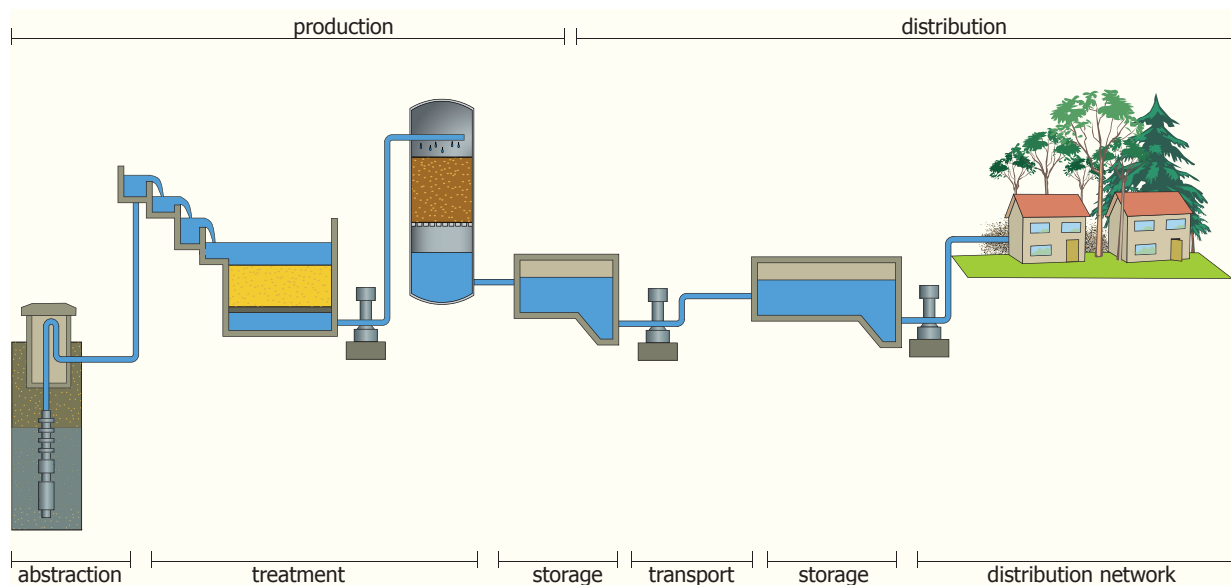

Figure 1 - Setup of the drinking water supply system

tamination or a small disturbance in the production process may cause the standards to be exceeded. Also, bacteria populations may develop during long retention times in installations or pipes.

2. Drinking water resources

Most of the water on earth (97%) is salty whereas only 3% is fresh water, from which more than two thirds is frozen. The unfrozen fraction is predominantly underground water leaving a small fraction to surface water (see Figure 2).

For the production of drinking water, almost exclusive use is made of water containing only a limited amount of dissolved compounds (fresh water). This choice is made in view of the high costs of removing salts from water.

Desalination of brackish water or sea water is only used in drinking water production when fresh water is scarce, like in arid areas (Saudi Arabia, Libya) and on tourist islands (like Malta, Aruba or Bermuda).

Thus, the main sources for production of drinking water are fresh groundwater and surface water.

3. Production

3.1 Groundwater

Groundwater can be abstracted in substantial amounts if an extensive, porous aquifer is available and if recharge from the surface or the surroundings is possible.

For drinking water production it is important that the aquifer is more or less isolated from the upper soil (confined aquifer) to avoid contamination. In order to further prevent contamination, the abstraction area is marked as such, according to strict regulations regarding land use and the use of dangerous compounds (oil, pesticides, etc.).

In areas where the aquifer has an open connection to the upper soil, the water abstraction area is

chosen considerably more carefully. In general a minimum retention time of 50 years in the underground is used to determine the size of the water abstraction area..

Groundwater abstraction influences the water level in the soil. This may cause desiccation of the surrounding area, resulting in agricultural and environmental damage. Therefore, permits are required for groundwater abstraction, in which the maximum amounts to be abstracted are regulated (yearly, monthly and daily maxima).

Due to the long underground retention time, groundwater is usually microbiologically stable and of an almost consistent good quality.

All water

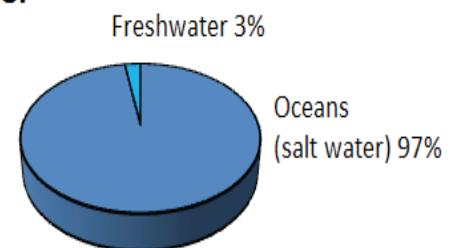

Freshwater

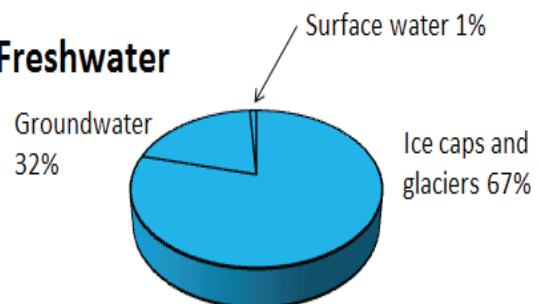

Figure 2- Fractions of water on earth

These properties mean that often, only limited and relatively simple treatment is necessary.

The chemical composition of the water, however, strongly depends on the local circumstances, which may cause wide differences.

The most important factor determining the quality of groundwater is related to the oxygen content of the water or to the degree of oxygen shortage (aerobic/ anoxic/ anaerobic)

The oxygen content actually determines the amount to which a few undesirable compounds can dissolve from the soil (iron, manganese, ammonium, methane, hydrogen sulfide).

Generally, the oxygen content can be easily predicted based on the origin of the groundwater (Figure 3). Though rainwater contains oxygen in all cases, this oxygen can be consumed by the decay of organic compounds in the soil. Besides, a longer retention time in the ground yields a lower oxygen concentration (water under a clay layer).

Aerobic groundwater is mostly abstracted from the phreatic sand layer. It contains oxygen and typically needs only very little treatment.

Anoxic groundwater is typically located under a continuous clay layer in the underground. Due to this layer, no oxygen is present in the water, but ammonium, iron and manganese are. These compounds are undesirable in the water and they need to be removed. However, the concentrations of these compounds are rather low.

Anaerobic groundwater is typically located below a peat layer. This water is characterized by the absence of oxygen and nitrate and by the presence of ammonium, iron, manganese, methane and hydrogen sulfide.

A second important factor in determining the quality of groundwater is its pH value.

Rainwater always contains a small amount of carbon dioxide (CO_2), though at larger concentrations, in industrial countries.

Because of the oxidation of organic matter (formation of CO_2), the CO_2 concentration in the groundwater may dramatically rise. In acid environments undesirable metals like nickel and aluminium may also dissolve from the soil matrix.

Carbon dioxide may react with limestone in the ground, causing the pH value to increase, but also causing a considerable increase in the hardness and bicarbonate concentration of the water.

A third factor determining the quality of the groundwater is related to land use. Due to fertilizing in agriculture, the amount of nitrates in groundwater

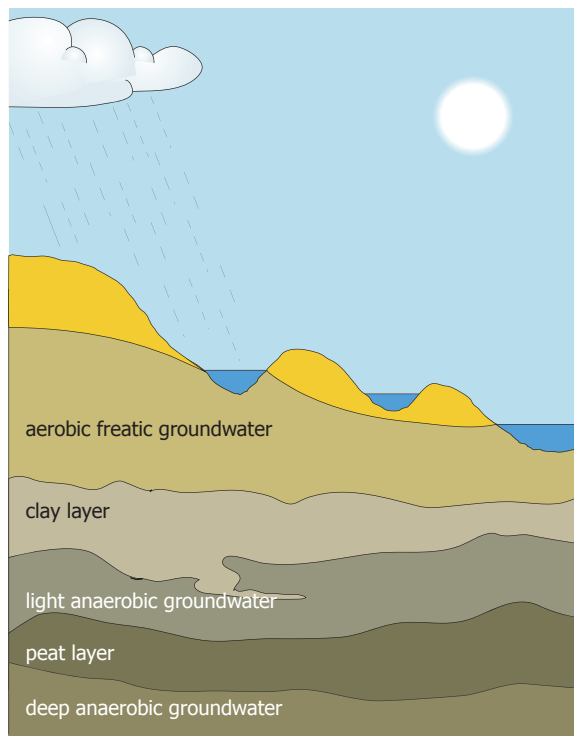

Figure 3- Consumption of oxygen in the soil has an influence on the composition of groundwater

can significantly increase (Figure 4) and, in addition, pesticides may enter the groundwater.

Finally, industrial contamination of the soil influences the quality of the groundwater.

Because of the variety of differences in water quality prior to treatment, there is no uniform treatment setup for groundwater. In the Netherlands, almost exclusively well-protected anoxic groundwater is abstracted, requiring aeration and rapid filtration in any treatment process (Figures 5 and 6). Aeration brings oxygen in the water and removes the dissolved gases, like carbon dioxide. After this, iron, manganese and ammonium oxidize, causing these compounds to be removed in the subsequent filter. To reduce the amount of abstracted water, the water companies also treat and reuse the backwash water from their rapid filters.

Being abstracted directly adjacent to surface water, riverbank groundwater is a mixture of aerobic "surface water" infiltrated into the soil, via the riverbank, with natural anoxic or anaerobic groundwater.

Since its main fraction is natural groundwater, riverbank groundwater is anoxic or anaerobic.



Figure 4 - Contamination of the soil is a threat to the quality of groundwater

Therefore, aeration and filtration are also in the basis of riverbank groundwater treatment. However, eventual iron flocculation, due to the mixing of anaerobic groundwater with aerobic surface water, makes that groundwater wells may clog.

The retention time of the river water in the soil is from one month to longer than one year and the flow velocity in the ground is about 0.1 m/d. The variations in quality (salinity, and temperature) are levelled off by the retention time and dispersion in the soil and therefore the vulnerability of riverbank groundwater to calamities is small.

When the river is contaminated, the infiltration of water into the soil cannot be stopped causing contaminations to enter the soil.

Therefore, the treatment setup of a riverbank groundwater plant is typically extended with activated carbon filtration (combined with UV treatment) to remove organic micro-pollutants (e.g. pesticides) from the water.

The capacity of a pumping station is related to the number of wells that can be constructed. Generally, pumping stations are small, of a size similar to that of a groundwater plant. The sites are usually located not far from the distribution area. Because of the short transport distances and the simple treatment setup (compared to surface water projects), the investment and exploitation costs are relatively low.

3.2 Surface water

Surface water is commonly available in large amounts and it is easily abstracted (rivers and lakes). In the case of rivers having a low minimum discharge, sometimes very large storage reservoirs are constructed to cover drier periods.

Drinking water production from surface water requires an extensive treatment process. Typically, it is necessary to remove suspended solids, turbidity, pathogenic micro-organisms, as well as organic and inorganic micro-pollutants (e.g. pesticides and heavy metals).

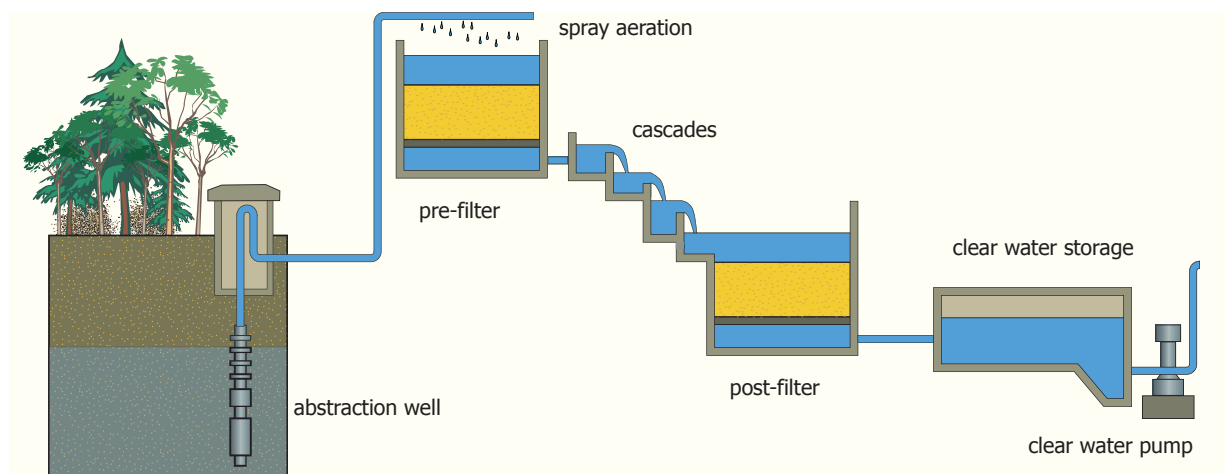

Figure 5 - Drinking water production from slightly anaerobic groundwater



Figure 6 - Modern design of Welschap pumping station (Noord-Brabant) where anaerobic groundwater is treated to produce drinking water

There are two systems for the production of drinking water from surface water:

- storage in reservoirs followed by an extensive treatment process (direct treatment)
- pre-treatment, soil aquifer recharge and abstraction followed by a limited post-treatment (surface water using soil aquifer recharge)

Figures 7 and 8 show the production sites of drinking water and the origin of drinking water, respectively.

3.2.1 Surface water using direct treatment

When abstracting river water for direct treatment to drinking water, significant variations of water discharge and quality should be considered. Besides, surface water is rather vulnerable to pollution.

For these reasons a storage reservoir is required before the treatment process itself.

The surface water that is used as a source for drinking water production is usually located at a large distance from the distribution area., requiring long transport distances (see Figure 9).

In order to prevent sedimentation and biological growth in the transport pipes, either the total treatment process is situated at the inlet site or a pre-treatment plant is constructed there. The main treatment plant is then constructed near the distribution area.

Reservoirs

In the Netherlands, the surface water used for drinking water production is mainly abstracted from the Rhine and Meuse rivers. Due to the large fluctuations of quality and quantity., water abstraction from the river is not always possible. In order to be able to supply drinking water, a storage reservoir should be available to cover periods of intake interruptions (Figure 10).

In most cases, the results of a contamination are only known a week after doing analysis. Therefore, there is usually an analysis reservoir or compartment situated before the storage reservoir..

Moreover, these reservoirs are also large to allow for a long retention time. The flow velocity in a reservoir is much slower than the flow velocity in a river, causing the settlement of suspended solids. A dampening of concentration peaks is also

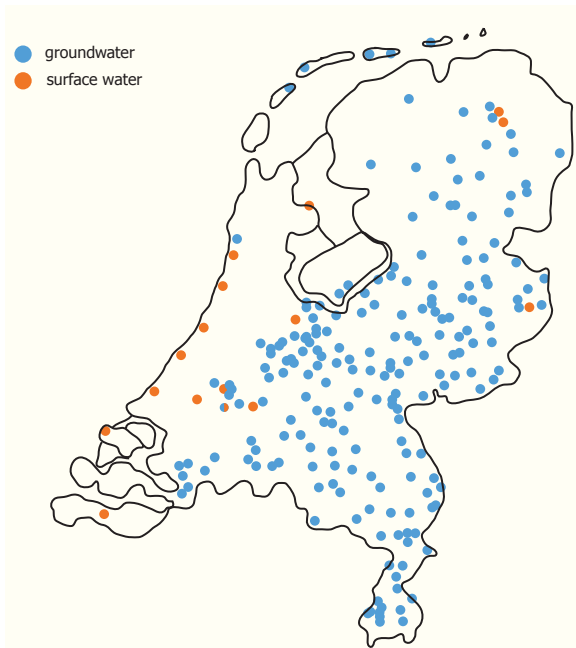

Figure 7 - Sites for the production of drinking water in the Netherlands

achieved. However, because of the mere size of the reservoirs, the processes in them are not fully controllable. Weather and wind have a substantial influence on the processes.

Because of the long retention time in the reservoirs, some suspended particles settle and are removed from the water. However, colloidal particles will not settle, because of their size and their stability.

To remove these particles, coagulation-flocculation is necessary. Coagulation is the process of adding positively charged salts to the water (iron or aluminum salts, Figure 11), to reduce the negative charges of the colloidal particles and destabilize them. Flocculation is the subsequent process where neutralized particles collide to form larger flocs..

After the flocs have formed, they need to be removed. This can be done in two ways (see Figure 12). The first method is to let the flocs, which have a density slightly higher than that of water, settle to the bottom (sedimentation). The second method is to let them collide with small air bubbles, causing the density of the flocs decrease below that of water, thus making them float (flotation).

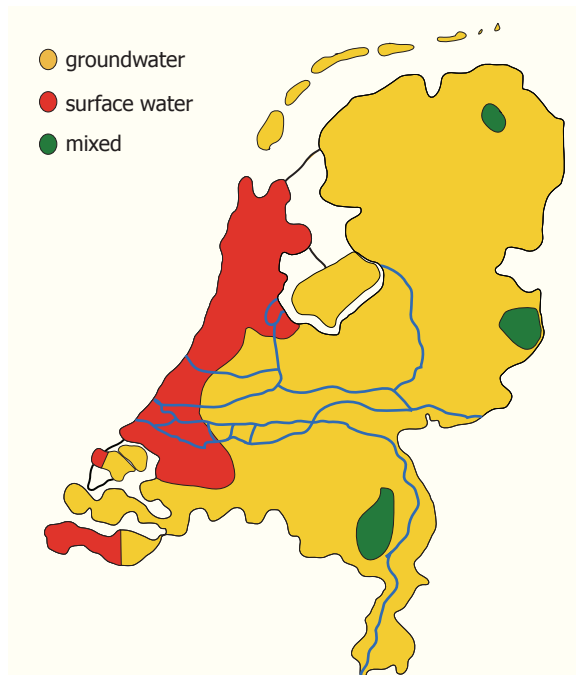

Figure 8 - Origin of drinking water in the Netherlands

The removed flocs also contain heavy metals, organic matter, and viruses.

Not all flocs are removed during sedimentation or flotation. Small flocs may remain in the water and may be removed using rapid sand filtration.

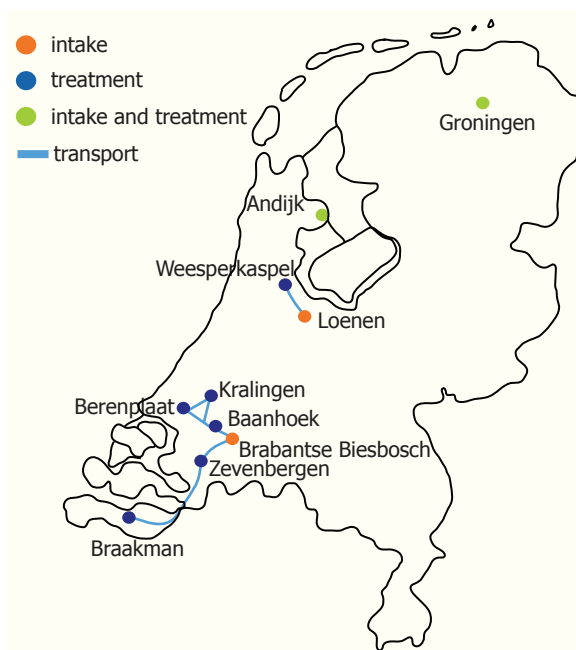

Figure 9 - Direct production of drinking water from surface water in the Netherlands



Figure 10 - The three Biesbosch reservoirs for the drinking water supply in the southwestern part of the Netherlands

In 1987 small amounts of the pesticide Bentazon were found in the drinking water of Amsterdam, the Netherlands. This pesticide was probably present in the water for a long time, but because analytical capabilities to detect these micro-pollutants were not yet well-developed, this contamination could not be proven before then. The detection of Bentazon in the drinking water initiated more extensive monitoring campaigns towards the presence of other micro-pollutants present in the surface water.

Organic micro-pollutants (e.g pesticides) can be removed from the water using activated carbon filtration, which is somewhat similar to rapid filtration, but uses activated carbon grains instead of sand. Activated carbon is able to adsorb organic micro-pollutants until it becomes saturated. At that moment the activated carbon needs to be regenerated.

Activated carbon filtration is typically used after rapid filtration, where any remaining flocs will be

retained. The activated carbon filter is therefore not loaded with suspended material, so it rarely needs to be backwashed.

Surface water also contains many pathogenic micro-organisms. These micro-organisms enter the water through sewage - mostly treated - and the drainage of pavements.

Disinfection, i.e, the removal or deactivation of pathogenic micro-organisms, is partially obtained by floc removal and rapid filtration, but this removal is not sufficient, which requires an additional treatment step.

In the past, chlorine was applied for this purpose but due to its harmful side effects, it is not used in the Netherlands anymore.

Other methods of disinfection include the use of ozonation and Ultra Violet light (UV). Ozonation applies the strong oxidizer ozone to kill pathogenic micro-organisms. However, the use of ozone is also hindered by some harmful side effects.

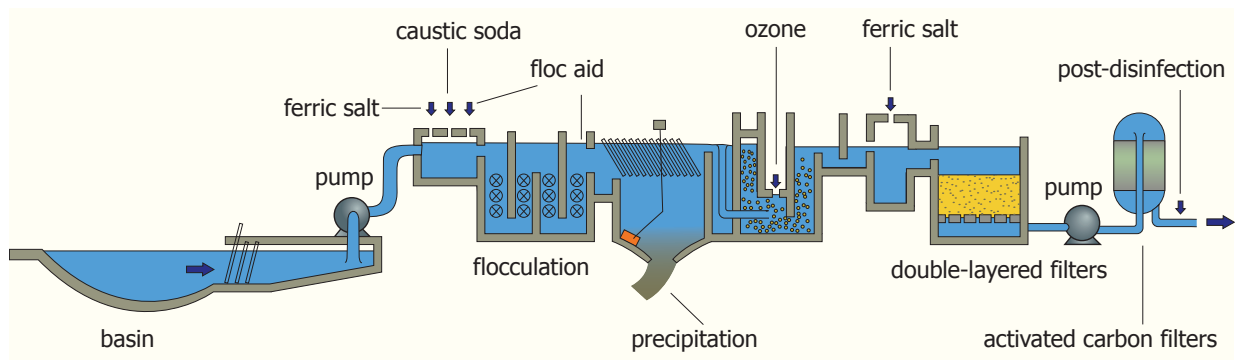

Figure 11 - The production of drinking water from surface water with direct treatment

UV disinfection treats the water with UV radiation inactivating pathogenic microorganisms.

3.2.2 Surface water using soil aquifer recharge

An example of surface water using soil aquifer recharge is found on the Dutch dune areas

The many small lakes (Figure 13) found in those areas, are often recharge facilities that have been used for quite a long time to produce drinking water.

Originally, the dunes were only fed by rainwater and dune water was only used by the local population. After 1853, the dune water supply was extended to Amsterdam as well. The amount of abstracted water increased further and further. As a consequence, some wells yielded salt water during the 1950s.

Since that time, surface water is pre-treated before being infiltrated into the dunes, in order to push

back the salt water and to maintain a fresh water barrier.

The pre-treatment prevents the clogging of the pipes and contamination of the infiltration area. The infiltrated water comes from the major rivers and lakes, in most cases, and needs to comply with the requirements of the Infiltration Regulation. Therefore, the pre-treatment of recharge water can be extensive (Figure 14).

After the water has been re-abstracted, it is post-treated, because it has become anoxic during the soil passage and therefore contains iron, manganese and ammonium. The post-treatment is thus similar to the set-up of the treatment of groundwater.

The infiltration areas act as a storage system to cover periods in which the surface water is contaminated and to reduce quality fluctuations. After the post-treatment, the water is transported to a reservoir near the distribution area, from where it is distributed.

Table 1 shows the total amounts of drinking water produced from surface water through soil aquifer recharge in The Netherlands.

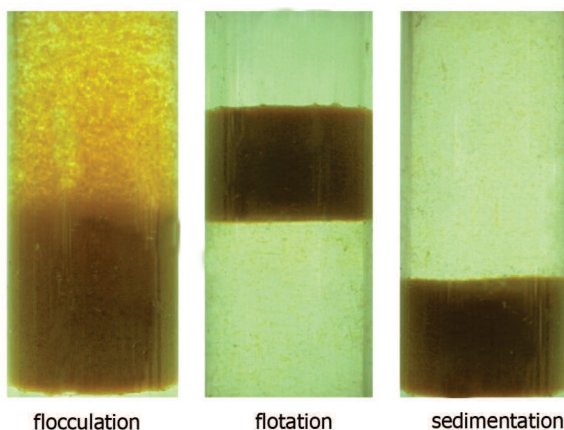

Figure 12 - Flocculation, with floc removal via flotation or sedimentation

4. Transport and Distribution

4.1 Transport

In the setup, shown in Figure 1, there is a large distance between the production plant and the supply area, which is bridged by a transport system.



Figure 13 - Infiltration area in the Dutch dunes

tem. Transport systems consist of both pipes and pumping stations, where the necessary pressure is provided (Figure 15).

The Dutch water companies have a total of about 500 kilometers of transport pipes which have diameters between 400 and 1,000 mm.

A transport system is designed based on the maximum daily use (measured once every ten years) of the supply area. The pressure in the transport system is determined by the height of the water level in the storage reservoir and by the hydraulic resistance.

4.2 Storage

The setup in Figure 1 shows that storage takes place in (drinking water) reservoirs. These reservoirs are often called “clear water tanks”. They achieve a dampening of the daily use fluctuations, so that production and transport can continue on a more or less constant level. The required capacity of clear water reservoirs is roughly 25% of the daily use (or the daily production), or the production of 6 hours.

Table 1 - Amount of infiltration at Dutch drinking water companies (VEWIN 2001)

Water balance infiltration	Amount (million m ³ /y)
Total infiltrated amount	213
Total abstracted amount	219
- abstracted from the dunes	181
- abstracted elsewhere	38
- change in storage volume	-6

At the Dutch production sites, storage of 1,500 to 10,000 m³ of drinking water is available. Because of supply uncertainty in the case of maintenance or defects, this storage capacity is subdivided across several distinct reservoirs or compartments. Clear water reservoirs are, of course, closed to maintain the quality of the drinking water. For the “respiration” of these reservoirs - when the water level changes, air will flow in or out - special air filters are employed.

In Figure 16 the clear water reservoirs and their relatively large size at the Berenplaat production plant of the Rotterdam water supply are clearly discernible.

Water towers generally contain between 250 and 1,000 m³. These towers barely play any role in the dampening of fluctuations in use. They mainly dampen the pressure, for short periods and in case of a severely fluctuating demand. In former days water towers were used as water hammer vessels for the distribution pumps. When the water level in the tower fell, an extra distribution pump was switched on. In this way, water towers could maintain a relatively constant pressure and could also guarantee some minutes of delivery even after a power failure at the distribution pumps.

4.3 Distribution network

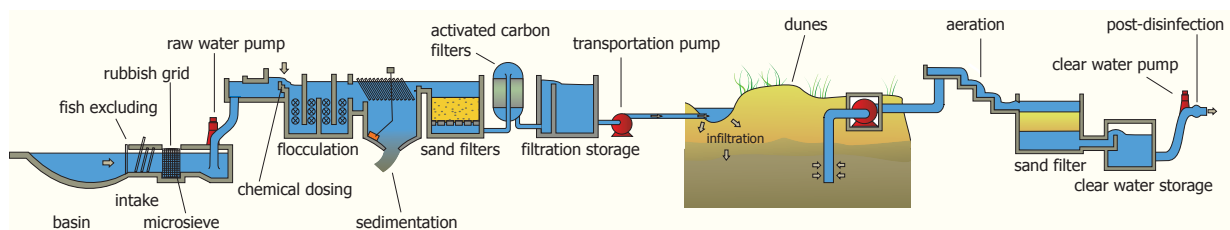

Figure 14 - Pre-treatment, infiltration and post-treatment of infiltration water



Figure 15 - Pumps used for the transportation of drinking water

From the storage reservoirs, the drinking water is pumped into the distribution network using high pressure pumps. Figure 17 shows an overview of a distribution network for a water company in a rural area. From the production site (pumping station), there are pipes going to the different villages and hamlets, where there is a water pipe in every street with houses.

In the Netherlands, there are over 100,000 km of water pipes with an external diameter over 50 mm, which amounts to about 7 m per inhabitant. The smaller branches and home connections are not included in this pipe length. Those additions will make the total pipe length per person about 10 - 13 m. In the distribution network, pipes may have a diameter up to 1,800 mm (Rotterdam), but

the majority of them have a diameter between 75 and 150 mm.

The design criterion for a distribution network is to maintain a supply pressure of 20 m above ground level (200 kPa) in the farthest branches of the network (at the home water meters). In order to achieve this, a minimum pressure of 25 m above ground level (250 kPa) in the streets is usually targeted. In rural areas with remotely situated clients, this might imply that during maximum demand there should be a pressure of 60 m above ground level at the production site. During the night, though, a pressure of slightly over 25 m will suffice, because during very low use the hydraulic resistance of the network will be very small. Near the production site, therefore, there would be large pressure differences.

Actually, the differences will not be that great in practice, because there seldom is a “maximum day” and because the difference between the normal demand and the maximum demand is relatively high (Figure 18).

To keep the pressure in the distribution network within certain boundaries, in some cases, boosters are used. These are pumps which have been constructed in the pipe to bring the water to a higher pressure.

In an area of variable topography, the distribution network is subdivided into different pressure zones. This prevents a high distribution pressure in the lower areas. When water is produced in the

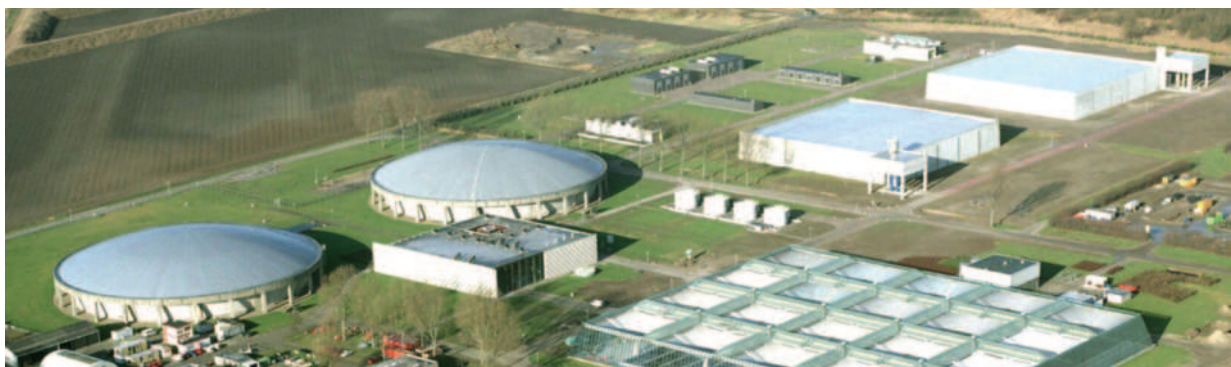

Figure 16- The round and square clear water reservoirs at the Berenplaat production site (Zuid-Holland)

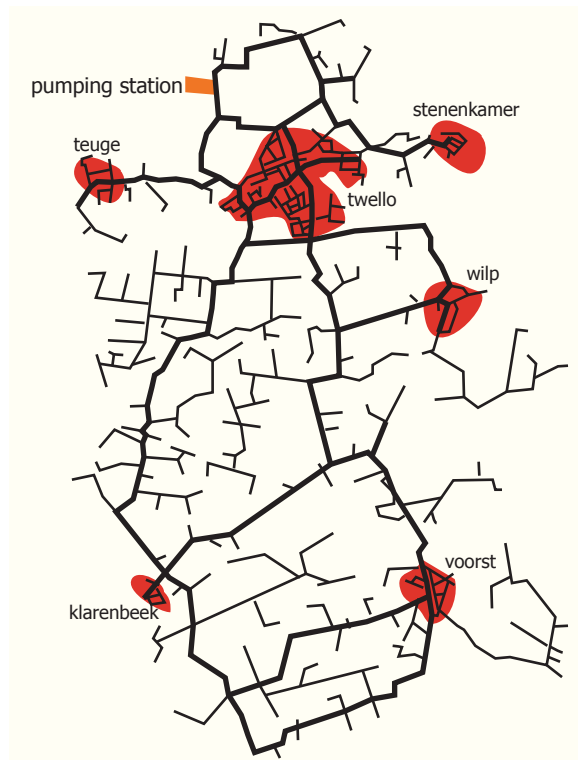

Figure 17 - A distribution network in a rural area

lower regions, pumping energy is also saved by this practice.

In apartment buildings it will be impossible to have sufficient pressure on the upper floors. Therefore, those dwellings are equipped with booster installations which consist of pumps and a pressure tank. The pressure tanks function as a water hammer vessel and for pressure smoothing.

The underground distribution of drinking water is virtually invisible. And, above ground, only the water towers can be seen (Figures 19 and 20). Today, water towers are no longer necessary. Speed-controlled pumps can deliver any desired amount of water on a continuous scale. Emergency power aggregates can provide power within 30 seconds and water hammer vessels at the distribution pumps have a sufficient capacity to cover this period.

Every dwelling is connected to the street water pipe through a home connection, which is also called a service pipe. The home connection ends

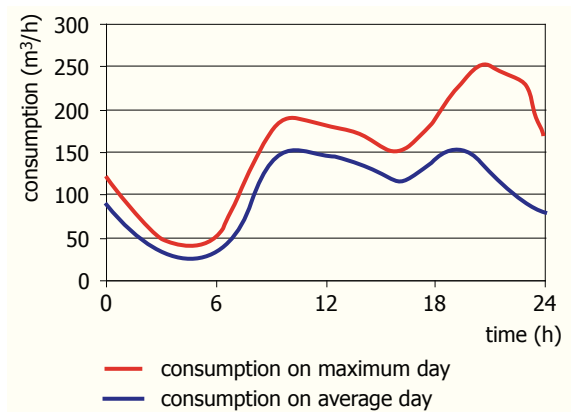

Figure 18 - Model for water consumption on an average day and on an extreme day

at the water meter, after which the client is the owner of that water.

In the Netherlands there are about 6 million technical connections to the drinking water network, of which 5.7 million are for small users. Ninety-six percent of all connections have a meter.

Table 2 indicates the lengths of the pipes of the Dutch water companies, per pipe material (service pipes excluded). The total length of over 100,000 km increases some 2.5% per year, mainly because of the development of new residential areas (new 3%; 0.5% removed). The low removal percentage suggests a pipe lifetime of 200 years. The technical and economic lifetime of pipes is shorter, which suggests that more pipes will need to be changed in the future.

Formerly, cast iron was used for pipes of smaller diameters. Nowadays, those pipes are mostly made of plastics (PVC, PE). Because of the sustainability and costs, asbestos cement, was often used for the middle-sized pipes. Due to the health risks of working with asbestos cement, its use is no longer permitted. The consequences of this for existing pipes are currently being discussed.

4.4 Drinking water installations

Before the last world war, the sanitary equipment for social housing was limited to a kitchen tap and a flushing toilet. Nowadays, a shower or a

bath is also deemed necessary. Even, more and more bedrooms are equipped with washbasins. In addition, the single tap in the kitchen or in the garden shed has been extended by connections for a washing machine and/or a dishwasher. The garden tap is no longer only used for watering the garden or cleaning the pavement, but for cleaning the car as well. This “water civilization” has made the sanitary installation quite a complex system of pipes and installations.



Figure 20 - Water tower in Dokkum

Table 2 - Lengths and (most common) diameters of the distribution pipes of Dutch water companies, excl. pipes with an inside diameter <45 mm (VEWIN 2000)

Piping material	Length (1000 km)	(%)	Diameter (mm)
PVC	50	46	100 - 400
Asbestos cement	35	32	250 - 600
Cast iron	12	11	50 - 200
PE	4	4	50 - 100
Steel	3	3	> 500
Nodulair cast iron	2	2	> 500
Concrete	1	1	> 800
Other	1	1	-
Total	108	100	

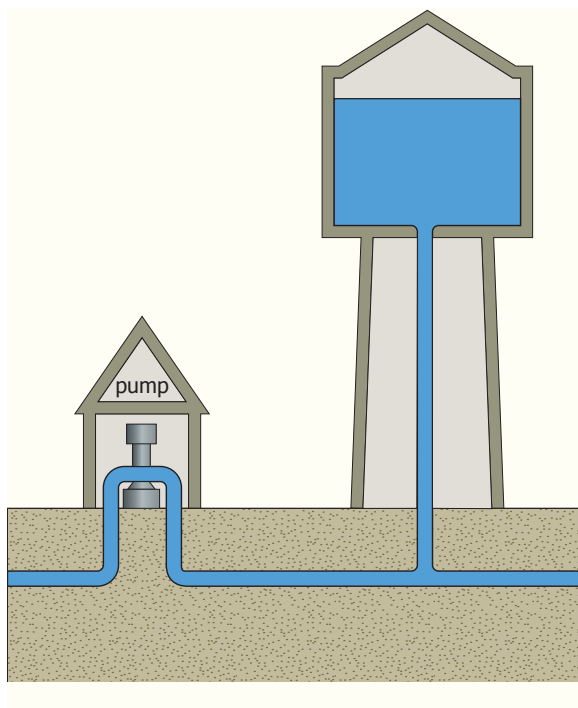

Figure 19 - Principle of a water tower

5. Planning and design process for public water supply

Extensive preparations are necessary in order to build drinking water production plants. The government plays an important role in the planning process, as public health is one of the main concerns. However, water companies are responsible for the construction and operation of the infrastructure.

Usually, it takes many years from the time the first idea for expanding water production facilities comes up, until the completion and start-up of the new plant. During this period, a highly diverse development process is carried out, involving many different specialties, such as environmental science, hydrology, hydraulics, structural engineering, electrical engineering, architecture, law, and economics.

The expansion of the infrastructure for drinking water production requires therefore a multi-disciplinary approach. A successful project requires a lot of organization. Besides, it is necessary to consider that the existing water supply must not be compromised during construction works.

The planning process for a public water supply is embedded in the general spatial planning process. The primary structure of and the hierarchy in this process in the Netherlands are summarized in Table 3. The planning process needs to comply with the legal framework, in which the Water Supply Act is especially important.

5.1 Identification

A construction project for public water supply can be initiated by different motivations. First of all, it is necessary to analyse which problem or problems must be solved with the project. Typical problems are:

- insufficient capacity due to growing demand
- decrease of production capacity due to a different source policy (i.e., reduction in groundwater abstraction)
- economic considerations: scaling up of plants
- technical obsolescence of current installations
- new requirements regarding the treatment process (more stringent quality levels or changes in raw water quality)

Within the water supply plan of the company and the multi-year investment plan, possible solutions are drawn up and provisional decisions are made. This is based on feasibility studies which compare several alternatives. Technological research leads to a general direction for the desired treatment process. Prior to the construction process, the following questions need to be answered:

- what, where, and what capacity needs to be constructed?
- when should it be completed?
- what needs to be achieved?
- what are the estimated costs?

These questions are answered in several preliminary studies, like:

- feasibility studies (technological, technical, financial, economic, environmental impact)
- location studies (possibility of land acquisition)
- literature studies
- project comparisons by site visits

Table 3 - Hierarchical planning process for the public drinking water supply in the Netherlands

Planning level	Name	Timeframe (years)	Organization
National policy plan	Policy plan for drinking and industrial water supply	20 – 30	Ministry VROM
National section plan	Ten-year plan	5 – 10	VEWIN
Provincial plan	Provincial policy plans	5 – 10	Province
	Provincial management plans	5 – 10	Province
Regional plan	Regional plans	5 – 10	Province
Municipal plan	Land use plans	5 – 10	Municipality
Company plan	Water supply plan	10 – 30	Company
	Multi-year investment plan	5 – 10	Company
	Business plan	5	Company

- specialist research (hydraulics, (soil) mechanics, ergonomics, material science, control engineering, physics, chemistry, environmental science, social aspects, etc.)
- system design studies (comparison of different treatment methods)

During these preliminary studies, the following data should be collected:

- existing plants (raw water source, process flow diagram, hydraulic scheme, drawings, operating experiences)
- surrounding area (drawings, descriptions, measurements, photographs) concerning foundations, soil conditions, groundwater levels, wires, pipes, roads, working areas, property rights, obligations, utility company connections, etc.
- necessary permits (provincial, municipal, water boards, spatial planning legislation, utility companies, public services, etc.)

The final part of the identification phase is the decision to start a new construction project.

5.2 Definition

To be able to begin a construction project, the following documents need to be drawn up::

- requirements program
- sketch design
- building scheme

Requirements program

The term “requirements program” is broadly used and has many different meanings, varying from a precise contract document to a general wish list. It is also applied to the collection of documents in the construction phase.

A requirements program is, preferably, limited to the purpose and outlines of the construction project, including:

- motivation for the project
- summary of preliminary studies
- purpose of the project
- wishes and side purposes
- future developments after construction

Based on the requirements program, a sketch design can be formulated.

Sketch design

In the sketch design, general options are considered, and the chosen one is sketched in terms of its technical and spatial outline. A sketch design can consist of the collection of relevant preliminary studies and reviews, as well as a more detailed items such as:

- treatment scheme (i.e., block diagram)
- rough hydraulic line scheme
- rough terrain arrangement
- phasing of construction
- cost estimation

A sketch design gives a good indication of the dimensions of the construction project. It includes, not only the construction phases but also the plan and terrain arrangements for future expansions. This design is important to inform all parties involved in the project’s next phases.

The building scheme can be formulated on the basis of the sketch design.

Building scheme

The building scheme is the general project plan, covering all aspects of the construction phase. It contains the full project definition and consists of:

- requirements program
- sketch design
- time schedule for design, contracting and construction
- design of the project organization (task setting between different parties involved in future studies and construction)
- estimation of investment costs (total project costs)

The building scheme is also important for internal decision making of the water company itself, including considerations such as the project mandate for organizational, technical, contractual and financial aspects.

5.3 Design

Designing a drinking water production plant is a creative process, influenced by several factors, of different importance and typically subject to personal preferences. These differences make

people to conceive different results. Thus, the design needs to be negotiated. The final design is a compromise between the parties involved (e.g., managers, economists, ecologists, PR-officers, designers, builders, etc.).

During the design process, it is important that the motivation for selecting the chosen solution is clear to third parties as well. The large number of parties involved necessitates an open planning so they have insight into the progress of the design and the effects on their own roles. A phased procedure, including a characteristic coarse-to-fine approach is necessary.

At the end of every design phase, a complete image of the construction should be presented. This will make clear not only the progress in that phase, but also the way in which the design might have been modified from prior phases. Often, besides the sketch design phase, three other design phases can be discerned:

- preliminary design
- final design
- detailed design

Changing the design

The coarse-to-fine approach is applied due to the need for design changeability. From identification to start-up, the project proceeds within smaller and smaller boundaries. This is expressed in:

- more precise estimations of costs
- more expensive design changes
- less freedom to change plans

In Table 4 some characteristic phases in the construction process have been quantified. The given values are indicative for a drinking water production plant.

Design documents

During the design process, a number of documents are prepared. It is desirable that these documents remain up to date, so they represent reliable images of the completed construction during later phases (not only during construction, but during actual operation as well). Figure 21 shows a diagram of the information flow during the construc-

Table 4 - Sketch of the construction process, upon completion of the different phases

Phase	Accuracy of costs	Changeability of design	Change in costs
Identification	± 50%	-	-
Sketch design	± 30%	100%	1%
Preliminary design	± 25%	40%	5%
Final design	± 15%	10%	10%
Detailed design	± 5%	2%	25%
Building	± 1%	-	100%

tion's life cycle. Most of the information related to the various stages of the design is recorded in the design documents.

Preliminary design

The preliminary design is intended to give a rough layout of the plant's elements, including their location, size of buildings and a description of any large mechanical or electronic devices needed by the plant during operation.

Also during this phase, the different construction forms for the desired process will be considered, possibly including a detailed preliminary design of the different options. A consideration of costs, operation, flexibility, robustness, etc. makes these details necessary.

Activities for the preliminary design include:

- processing of responses to the sketch design
- discussing the design with other stakeholders, like government agencies, suppliers, third parties

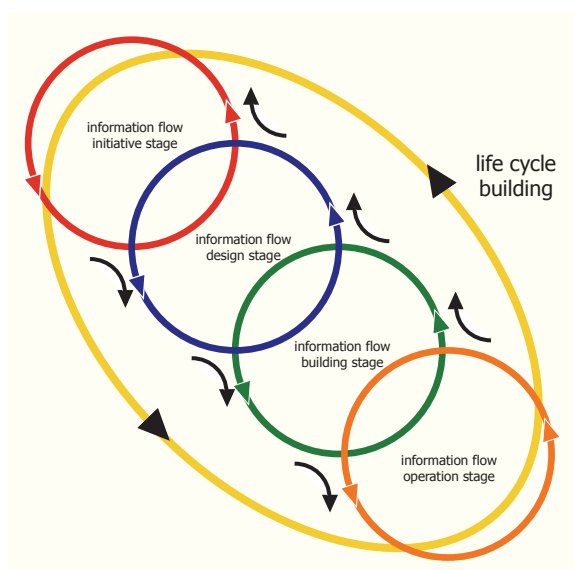

Figure 21 - Design documents provide information for the building and operation phases

-
- formulating process descriptions
 - formulating the necessary technical design drawings for the different operating conditions (minimal, maximal and normal capacity) among which are:
 - process flow diagram (PFD) (including rough balance sheets of water, energy and chemicals)
 - hydraulic line scheme
 - rough design of buildings (necessary space, building height)
 - calculating rough dimensions of buildings and determining their sizes
 - formulating construction drawings (floor plans, sections, views)
 - specifying main components of (civil) structure (foundation, materials, architecture, spatial coding)
 - specifying main components of mechanical installations (capacity, number, type, material)
 - specifying main components of electrical installations, instruments and control systems
 - formulating rough estimates of:
 - construction costs
 - operation costs
 - construction time
 - handing out documents for approval of the results of the preliminary design

Final design

The final design follows directly from the preliminary design. This design is more detailed and contains construction drawings and the calculations of those parts which were considered “black boxes” during earlier phases.

Activities for the final design consist of the following elements:

- processing responses to the preliminary design
- discussing the design with other stakeholders like government agencies, suppliers, third partners
- calculating final capacity and dimensions
- elaborating preliminary designs into final construction drawings
- formulating:
 - process flow diagrams (PFD) for mainstream and secondary flows (chemicals, energy, sludge treatment, backwash water treatment)
 - hydraulic line scheme
 - piping and instrument diagrams (P&ID)

- control schemes based on an automatization master plan
- deciding on necessary space for auxiliary facilities
 - preparing requisitions for technical details and prices of necessary installations
 - preparing requisitions for necessary permits including completing necessary documents
 - discussing financial topics and contracts
 - discussing the method of contracting
 - estimating investment costs and completion time
 - handing out documents for approval of the final design

Detailed design

The detailed design focuses on the construction part of the project. For the concrete structure, this refers to reinforcement calculations, drawings and finishing elements (façades, window frames, partition walls, roofing, etc.).

The mechanical part of the installation is elaborated upon with respect to the pipes (support constructions, division of pipeline parts, detailed design of vessels and appurtenances).

The electrical installation deals with cable calculations and control board design, for example.

The control system is concerned with the design of control and computer programs.

5.4 Contract

In almost every project, the actual building is done by contractors and suppliers.

This makes it important, then, that the principal be provided with the expected construction and goods of the required quality, at the agreed upon price, and at the pre-set time. Therefore, offers need to be requested that can serve as future contract documents, and later checked to determine whether the delivered item agrees with the negotiations and what the consequences will be for diverging from those plans.

Commonly, contracts are agreed upon with many bidders. This is because most bidders only can deliver within a very specific range or because they cannot guarantee quality for the entire project.

Though a great variety of contracts exist, both in type and in range, the following steps can always be expected:

- formulating contract documents (specifications)
- requesting bids
- granting bids

Due to the large number and variety of contracts and to the necessity of monitoring all forms of progress, a separate department is charged with contract writing.

Specifications

The specifications consist of a detailed description and drawings of the plant. The goal is to give as accurate a picture as possible of the various parts of the plant.

The specifications have the following functions:

- it is the chief source of information for describing the work to be conducted, so an accurate price can be set
- it is one of the instruments for steering, controlling and supervising the building process
- it is part of the contract, together with a description of tasks, rights and obligations of both parties

5.5 Construction, start-up and operation

After the project has been assigned, construction begins. Only seldom is a structure built on a location where no disturbance of the present production takes place (Figure 22).

Because of the hygienic nature of drinking water supply, special measures to prevent contamination of the operation's production process need to be taken.



Figure 22 - The building area is 3-6 times larger than the building

Estimating investment costs

A surface water treatment plant of 20 million m³/y (design capacity 3,200 m³/h) consists of several processes, like those below.

Process part				
Flocculation	Residence time	20 min	Volume	1,070 m ³
Flotation	Surface load	15 m / h	Surface	215 m ²
Filtration	Surface load	7 m / h	Surface	460 m ²
Activated carbon filtration	Empty bed contact time	15 min	Volume of carbon	800 m ³
Clear water storage	Volume	20,000 m ³		
Clear water pumping station	Capacity	5,760 m ³ / h		

Based on these process units, the investment costs (level of policy plan or sketch design) are estimated using the cost functions for the process units. The table below gives the result of the cost estimation.

Cost element	Costs (million €)
Construction and equipment costs for process units:	
- Flocculation	2.3
- Flotation	2.8
- Filtration	6.8
- Activated carbon filtration	6.7
- Clean water storage	3.7
- Clean water pumping station	7.3
Subtotal process units	29.6
Other (non-process related) investment costs (41% of subtotal process units)	
- Land costs (2% of subtotal process units)	12.1
- Other construction costs (5% of subtotal process units)	
- Additional costs:	
- Preparation and supervision (20% of subtotal process units)	
- Financing costs (10% of subtotal process units)	
- Other additional costs (4% of subtotal process units)	
Total investment costs	41.7

It is always necessary to work clean during the construction. A dirty building place will contaminate new parts of the plant as well. At the start-up, such contamination can be quite troublesome, making it difficult to attain the required microbiological quality of the drinking water being produced.

The main tasks for the water company during construction are:

- direction of the construction process
- supervision of the construction process
- conduction of guarantee measurements and takeover

At takeover, the water company begins the plant's operation. This includes the start-up of the production process.

Only after it has been proved that the plant truly produces reliable drinking water, can the water be supplied to the distribution network.

During this introductory phase, the operators need to become familiar with the installation.

After the start-up, the new plant will be included in the normal operation of the water company. During the production period it is not uncommon to replace whole installation components, due to technological obsolescence.

The main mechanical parts are seldom replaced. Rather, a whole new plant will be constructed.

5.6. Laws, permits and standards

Laws and permits

Building a production plant for drinking water supply is bound to normal legal obligations. Many of those regulations are carried out by permit procedures. Those require the intended activity to be specified, including the way it will comply with the relevant legislation. After the competent authority has approved the application, the legal requirement will have been fulfilled.

Typical permits for normal construction work are:

- tree cutting permit (making the area construction ready)
- building permit (for construction)
- environmental permit (for operation)
- draining permit (for discharge of drain water)
- abstraction permit for groundwater

Standards

Many permit procedures require the design to comply with specific standards. These standards

make up a rather complex system of technical directives and obligations.

Even when the permit does not necessitate it, testing the design against the standards is desirable in almost any case. On the one hand, this is because standards define several quality levels for the construction and, on the other hand, the standards create a more uniform design process. This improves the quality of the design and the efficiency of the design process.

Standards are important in regulating responsibility for the design. They also play an important role in fostering good communication between the different parties involved in a construction project, as standards define the meaning of specific concepts as well.

Estimating operational costs

A surface water treatment plant of 20 million m³/y (design capacity 3,200 m³/h) exists for several processes, like in the previous example.

The operational parameters are given below.

Process unit				
Flocculation	Energy	24 Wh / m ³	Dosing Fe	5 mg / l
Flotation	Energy	50 Wh / m ³	Suspended solids (sludge)	20 mg / l
Filtration	Energy	12 Wh / m ³	Suspended solids (sludge)	5 mg / l
Activated carbon filtration	Energy	8 Wh / m ³	Regeneration	15,000 BV
Clear water storage				
Clear water pumping station	Energy	200 Wh / m ³		

Based on this, operational costs (sketch design phase) can be estimated as given below.

Process unit	Total	Fixed costs	Consumables	Maintenance	Specific operational costs	Administrative costs
	(€ / m ³)	(€ / m ³)	(€ / m ³)	(€ / m ³)	(€ / m ³)	(€ / m ³)
Flocculation	0.047	0.017	0.017	0.002	0.006	0.005
Flotation	0.053	0.022	0.017	0.002	0.008	0.005
Filtration	0.088	0.046	0.004	0.006	0.018	0.009
Activated carbon filtration	0.116	0.051	0.030	0.005	0.018	0.010
Clear water storage	0.039	0.025	0.000	0.001	0.010	0.003
Clear water pumping station	0.108	0.058	0.012	0.007	0.020	0.010
Total	0.446	0.220	0.081	0.024	0.081	0.042

6. Costs

6.1. Investment costs

Definition

The investment costs represent the total costs of developing a project or plant. These costs are paid during the preparation and construction of the project until the moment that the project (e.g., treatment plant) is taken into operation. From that moment on, the installation generates revenues and the costs afterwards are considered to be operational costs. Usually this timing corresponds to the date the completed construction is taken over by the principal (water company).

Investment costs can also appear during the operation period of the asset. Examples include expansion of the plant and replacement of major parts.

Table 5 shows the initial cost estimations for some functions

Investment costs and capacity

To transfer the investment costs of a realized project to a future project, the following questions are important to consider:

- is the treatment scheme of the projects equal?
- is the capacity of the projects equal?
- is the complexity and/or “luxury level” of the projects equal?

To compare production plants with different treatment schemes, investment functions per treatment process can be formulated. By adding the costs of the different processes, the total investment costs can be determined.

The complexity may differ per project. Sometimes the building permit only allows a very restricted building area, which means that a complex piled up construction is needed. Therefore, the investment costs are higher.

Also, aspects like representative buildings, with facilities for excursions, influence construction costs.

Because of these variations, the investment costs differ, even when the treatment scheme and capacity are equal. Differences of ±30% are

possible, which is a factor of 2 between the most expensive and the least expensive project design.

Scale factor

Of course, the capacity of the plant determines, to an important extent, its investment costs.

For the relation between capacity and investment costs, cost functions can be formulated.

The relation between capacity and investment costs are usually well described by the general formula:

$$K = a * (\text{capacity})^b$$

where:

K = investment costs (€)

a = costs factor (-)

b = scale factor (-)

In Figure 23 this relationship is given graphically for various scale factors. In this relationship the scale factor is the most important part.

Table 5 - Examples of investment cost functions for initial cost estimations

Process / Process part	Cost factor (€ / m ³ yearly capacity)
Production from groundwater	1.5 - 3.5
Production from bank filtration	2.0 - 4.0
Production from surface water (direct)	3.0 - 5.0
Production from surface water (soil aquifer recharge)	4.0 - 8.0
Groundwater abstraction	0.10 - 0.15
Aeration	0.10 - 0.15
Degasifying	0.20 - 0.30
Rapid sand filtration	0.30 - 0.55
Filter backwash water treatment	0.05 - 0.15
Raw water pumping	0.10 - 0.15
Microstrainers	0.05 - 0.15
Flocculation	0.10 - 0.25
Floc removal (sedimentation/flotation)	0.5 - 0.25
Rapid sand filtration	0.30 - 0.55
Activated carbon filtration (GAC)	0.50 - 0.90
Softening	0.35 - 0.60
Disinfection	0.05 - 0.20
Membrane filtration	1.00 - 2.00
Slow sand filtration	0.70 - 1.50
Clear water pumping station	0.40 - 0.70
Clear water storage	0.20 - 0.35

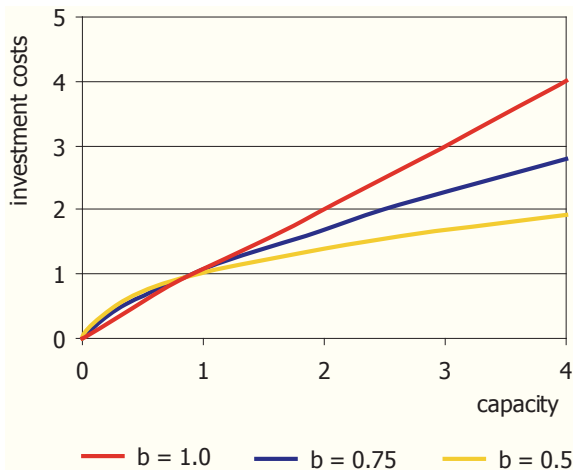

Figure 23 - Relationship between capacity and investment costs for different scale factors

The cost ratio of two different capacities depends only on the scale factor:

A scale factor of 1.0 indicates that there is a linear relationship between capacity and investment costs. This usually occurs when more of the same elements are needed for a larger plant, like in membrane filtration in which more of the relatively expensive membrane elements are necessary.

An example is rapid sand filters that, due to restrictions in backwash water facilities, are usually not larger than 30 - 50 m².

A scale factor of 0.6 - 0.7 occurs for process parts for which, at a larger capacity, the size of the elements increases. Reservoirs are a typical example. When the water height of a reservoir is selected, then with a larger volume the surface of the floor and roof will change on a linear scale with the volume (scale factor 1.0). The surface of the walls will change with the square root of the volume (scale factor 0.5).

In practice the scale factor for units of water production plants will be between 0.6 and 0.9, within the capacity range of factor 2 to 6.

6.2 Operational (exploitation) costs

The operational costs contain all costs which are made or will be made to use an object, construction or plant.

These costs are made during (parts of) the operation period of the installation or plant and after completion of the construction.

The operational costs are estimated to calculate the total cost price of the different parts of the company. This is important for the calculation of costs to the buyers, because there are different rates charged, such as to large consumers, for bulk delivery to other water supply companies, or for rate differences per part of the distribution area.

The operational costs will also be calculated when determining various alternatives during the preliminary studies. The operational costs will eventually be calculated back into consumers' rates.

A uniform and unambiguous concept definition is needed to explain and justify the operational costs.

A classification is given in Table 6. In the table a few typical cost items for drinking water supply are included.

7. The practice of designing (Heel example)

In the previous sections the basic elements of the design process have been explained. In the following, the design process will be further elaborated on using a concrete project: the construction of a new drinking water production plant, in Heel, for the Limburg Water Company.

The design is further discussed regarding the phases previously described and the necessary documents, according to the NEN/ISO 10628 "Flow diagrams for process plants."

The following items will be elucidated:

- preliminary studies
- sketch design and building scheme
- preliminary design
- final design and detailed design
- construction and start-up

Table 6 - Definition of operational costs (according to NEN 2632)

Part	Sub part	
1 Fixed costs	a1	Interest
	a2	Replacement reserve (depreciation of actual building costs)
	a3	Ground rent
	a4	Owners part real estate tax
	a5	Assurance costs (fire, glass, etc.)
	a6	Governmental contribution (taxes, levies, etc.)
	c1	Rent
	c2	Loss of rent
	c3	Environmental tax
	c4	Users part real estate tax
2 Consumables	b1	Energy costs (electricity and fuels) (maintain)
	c5	Energy costs (electricity and fuels) (use)
		Water
		Chemicals
		Other consumables (regeneration activated carbon, seeding material, etc.) Removal waste products
3 Maintenance costs	b2	Technical maintenance (maintain)
	b3	Cleaning maintenance (maintain)
	c6	Technical maintenance (use)
	c7	Cleaning maintenance (use)
4 Administrative management costs	a7	Accounting costs (property)
	b4	Accounting costs (maintain)
	b5	Rental costs
	b6	Administrative staff costs
	c8	Moving costs
	c9	Mediation costs
	c10	Accounting costs (use)
5 Specific operational costs	a8	Surveillance costs (property)
	b7	Surveillance and security (maintain)
	c11	Surveillance and security (use)
		Operation installations Quality monitoring

a – costs related to property ownership

b – costs related to ready-to-use maintenance

c – costs related to partial or complete use

7.1 Preliminary studies

Background

The water supply in Limburg fully relied on ground-water. Already in 1972, the "Drinking and industrial water supply structure scheme," suggested that for further expansion the use of surface water would be necessary.

In 1980, when desiccation became a political issue, a decrease in groundwater abstraction in Limburg was proposed. This would only be possible if the above project was completed.

Several investigations on decreasing desiccation suggested that the best solution would be to reduce all groundwater abstraction sites in

central and north Limburg by 50% of the allowed maximum - a maximum which was always used or even surpassed.

In 1993 the practical implementation was started. In 1995, the provincial government of Limburg and the Limburg Water Company agreed to construct the project, in combination with a decrease in groundwater abstraction. The construction started in 1998 and the plant started production in 2002.

Alternatives

Introducing surface water to decrease production of drinking water from groundwater plants, could be done in a threefold way.

In the first case all the groundwater would be transported to Heel, mixed there with the new plant's

production from surface water, and afterwards distributed over all north and central Limburg. An advantage of this is a uniform scheme and a constant water quality over the entire province (i.e., no local differences).

In the second case, the groundwater plants would supply the boundary locations of the distribution area, while the centrally located Heel site would supply the immediate surroundings. An advantage of this solution is that ground- and surface water systems would remain separated.

In the third case, the water produced in Heel would be transported to the different groundwater sites and mixed with the locally produced water there.

These alternatives have been thoroughly compared, by investigating the consequences for the water quality, distribution infrastructure, possibility for phasing the project, costs, reliability, etc. Of course, this needed several design activities. All three possible solutions would require extensive, extra distribution infrastructures (Figure 24).

Without describing the decision process in detail, the final decision was to add the surface water to the groundwater (Figure 25).

Water supply plan

In most cases the production capacity is not reduced drastically. Usually, the increase in the water demand leads to new production plants or capacity increase of current plants.

Figure 26 shows how such a demand coverage can be monitored. The net demand is shown, based on one of the different situations (minimum, maximum and most probable). From those figures and a reserve, a gross demand can be calculated.

New capacity is realized stepwise, making available a spare capacity. In a water supply plan, the calculations are based on yearly capacities. Based on the expected maximum peak factor, the maximum daily production can be determined.

The water supply plan describes which production plants need to be functional and when to increase



Figure 24 - For all alternatives, a considerable pipeline infrastructure was needed



Figure 25 - Surface water treatment in Heel supplies drinking water to the province of Limburg in addition to the existing groundwater plants

a plant's production capacity. The uncertainty in the predictions might lead to shifting the moment at which the additional capacity is realized.

To estimate the time when an extra facility to handle additional capacity will be required, one can calculate backwards to determine the last possible moment to start preparations for building the new plant.

7.2 Block diagram, site layout plan and sketch design

Besides the required capacity, the treatment process needs to be decided upon as well. The following research methods are used to come to this decision:

- evaluation of current experience
- investigation of new treatment techniques
- pilot research (semi-technical scale)
- full-scale research (temporary production plant)

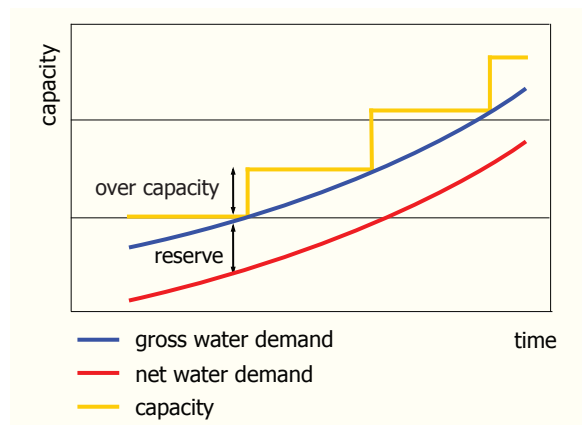

Figure 26 - Growth and coverage of water demand

Time and means do not always allow the use of all those methods. This increases the uncertainty of the process design and of the entire operation. In the plant this can be compensated for by increasing flexibility and safety in the design (larger buildings or increased possibilities for expansion) and in the operation (increased control options, increased doses). Either of these will increase the investment costs and complicate the operation. The start-up can take longer as well, because operators might not be familiar, or are less familiar, with the chosen treatment process.

Block diagram (treatment scheme)

The treatment process in this phase is represented as a block diagram (ISO 10628), which can also be used for treatment plants or other units.

The block diagram consists of named rectangular blocks, connected to each other by streamlines and it includes

the names of in- and out-flowing mass and energy flows (for the block diagram as a whole), as well as the directions of the main streams between the blocks.

Also, a block diagram may contain additional information, like the names of the flows between the blocks, the amounts of in- and out-flowing mass and energy flows, the amounts of the most important flows between the blocks, and the typical process conditions. A limited block diagram is shown in Figure 27.

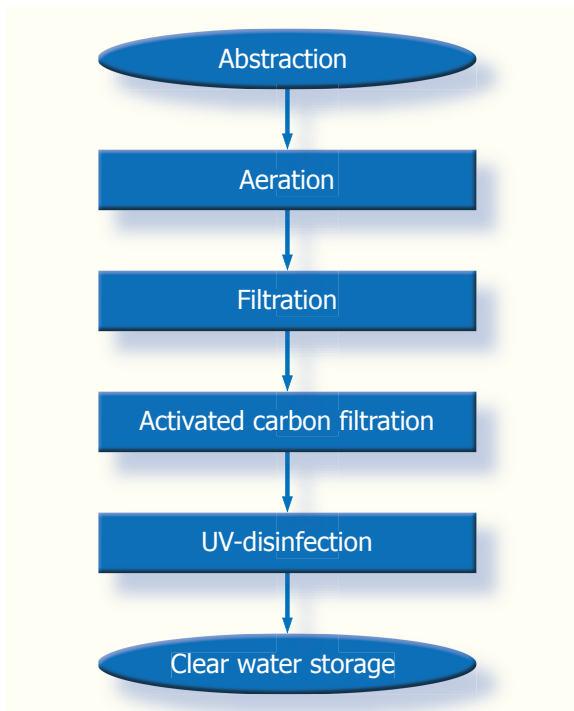

Figure 27 - Global setup of the treatment scheme

In addition to the block diagram, a more visual representation of the treatment process can be drawn. Mostly, this is a rough section of the process, including the most important pumping phases. Figure 28 shows an example.

Site layout plan

When the capacity and the treatment processes are roughly known, a provisional site layout plan can be drawn. This plan especially aims at the zoning of the plant area and at the related orientation of the buildings. Site layout plans are usually drawn at a scale of either 1:500 or 1:1000.

Typical zones within a site layout plan are:

- clean water reservoirs with high pressure pumping station
- treatment plant
- sludge and backwash water treatment units
- energy supply (including emergency power)
- additional services (e.g., workshops)
- main roads and transport routes
- space for future expansion

When formulating the site layout plan, the building boundaries are either not important or not yet known. Generally, the spatial demand per process part can be determined. The spatial demand of most processes (i.e., filtration, flocculation, sedimentation, etc.) is about 2 to 3 times as much as the actual area necessary for the process. This is because of necessary pipe galleries and control rooms. Besides, during construction a large space around the building is required.

Finally, it is desirable to consider future developments and replacements. For a replacement, the new construction should be finished before an old construction is demolished, to maintain continuity in the supply of drinking water. Figure 29 gives an artistic impression of the Heel production site.

Sketch design

In addition to the documents named above, formulating some very rough design drawings to present the intended construction to third parties may be desirable. Usually, a single floor plan and one or two sections will suffice.

The sketch design names the projected structures and their dimensions. The building scheme is formulated based on this design, including plans for the construction work (Figure 30). One should

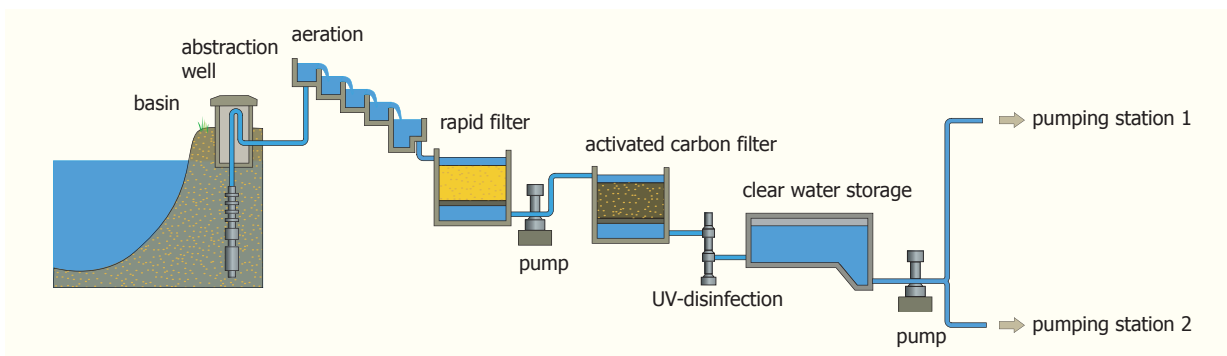

Figure 28 - Visual presentation of the treatment process



Figure 29 - Artistic impression of the Heel production site

keep in mind that this kind of planning tends to fail, for example, because of lagging permit procedures.

During preparation for the Heel production plant, it became clear that the gravel suppliers needed an extra year to develop the gravel pit and the adjacent shores. Partly because of this extra preparation time, it was possible to raise the operational level of the reservoir, which increased the groundwater level in the area and, thereby, reduced the environmental impact. The environmental impact was quantified as a part of the Environmental Impact Assessment procedure (EIA).

7.3 Preliminary design

The most important design documents in the preliminary design phase are:

- hydraulic line scheme
- process flow diagram
- design drawings

Hydraulic line scheme

The hydraulic line scheme is a typical design document for water treatment plants. Because of using open tanks, canals and processes with a free water surface (i.e., cascades), the water level in the processes becomes quite important, especially when an energy and cost-saving is desired. There are no national standards for the hydraulic line scheme. Basically, the hydraulic line scheme is a vertical section of the building, presenting the building elements schematically, and the relevant heights on an exact scale (Figure 31). In addition, ground level, roof height, passage height, and other relevant data are indicated.

During the design process, this scheme is refined and other levels (e.g., emergency overflow) are indicated.

Hydraulics plays a very important role in the design of a drinking water production plant. One reason for this is that the water will be divided over several parallel units more than once. Basically, a hydraulic division is used here, because of the robustness of hydraulic control compared to mechanical or electrical control systems (Figure 32). A hydraulic control system is often used to compensate for the increased filter resistance during the process.

Process flow diagram (PFD)

A further elaboration of the treatment process can be represented as a process flow diagram (PFD) (ISO 10628).

A PFD indicates installations, by means of standardized symbols, and the flow of mass and energy between them. At a minimum, it consists of the following blocks:

- type of equipment necessary for the process
- coding of the installation

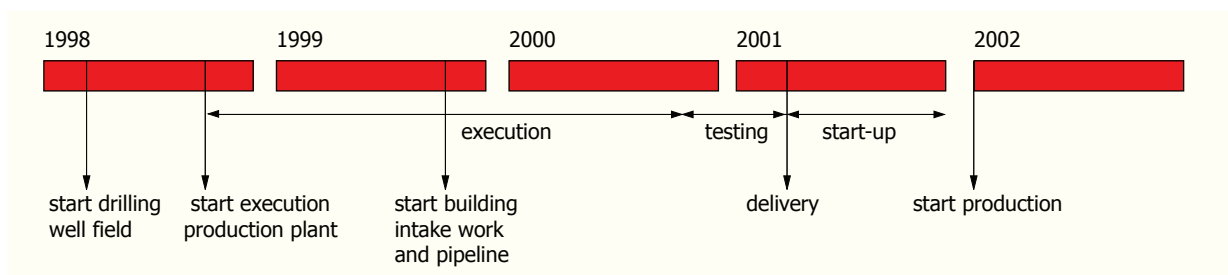

Figure 30 - Actual timeframe for construction of Heel production plant

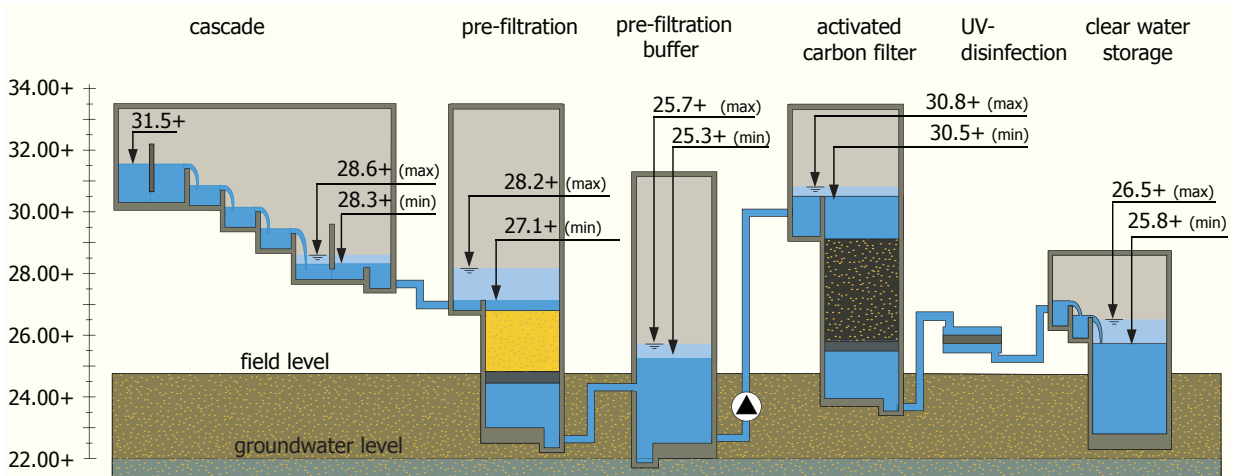

Figure 31 - Hydraulic line scheme

- direction and route of in- and outflowing mass and energy
- labelling and quantifying of in- and outflowing masses
- labelling and quantifying of in- and outflowing energy flows
- typical process conditions

Additional information can be included, such as the magnitudes of flows and amounts between process steps, major valves, functional indication of instrument and control systems in a specified position, additional process conditions, names of characteristic installation data, names and characteristic data of propulsion systems, and the elevation levels of terraces and installations.

For the design of a drinking water production plant, it is only useful to formulate a PFD in addition to the hydraulic line scheme when all parallel process

parts are presented separately. This makes the diagram correspond to the much used main water flow diagram (Figure 33).

This specification is desirable so that the PFD can be used to determine the different hydraulic loads of units and piping, both in normal and in special circumstances. For normal conditions one can describe the different process conditions with the diagram (e.g., filter during backwash, etc.). The extraordinary conditions determine the dimensions of the parts. In this way, the PFD is the basis for the detailed hydraulic calculations and the functional description of the control and operating system.

Design drawings

Design drawings represent the physical reality. During the preliminary design phase, especially the dimensions of the process units and the different rooms will be decided.

More and more, these drawings are made by 3D design systems (Figures 34 and 35).

Structural aspects

During the preliminary design phase, the dimensions of the structural elements cannot be determined accurately yet because the loads are only approximated. Nevertheless, it has proven feasible to make some realistic assumptions instead. For concrete constructions, the floor and wall sizes are mostly estimated at 0.4-0.6 m.

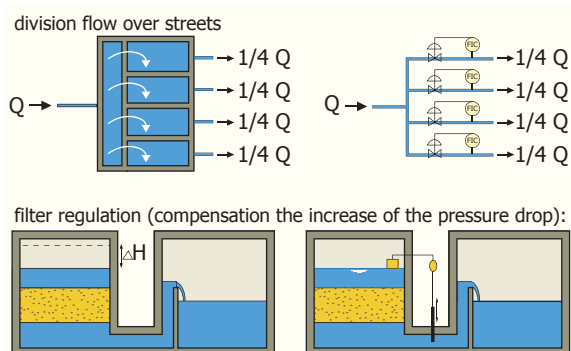

Figure 32 - Hydraulic solutions are easier and more robust

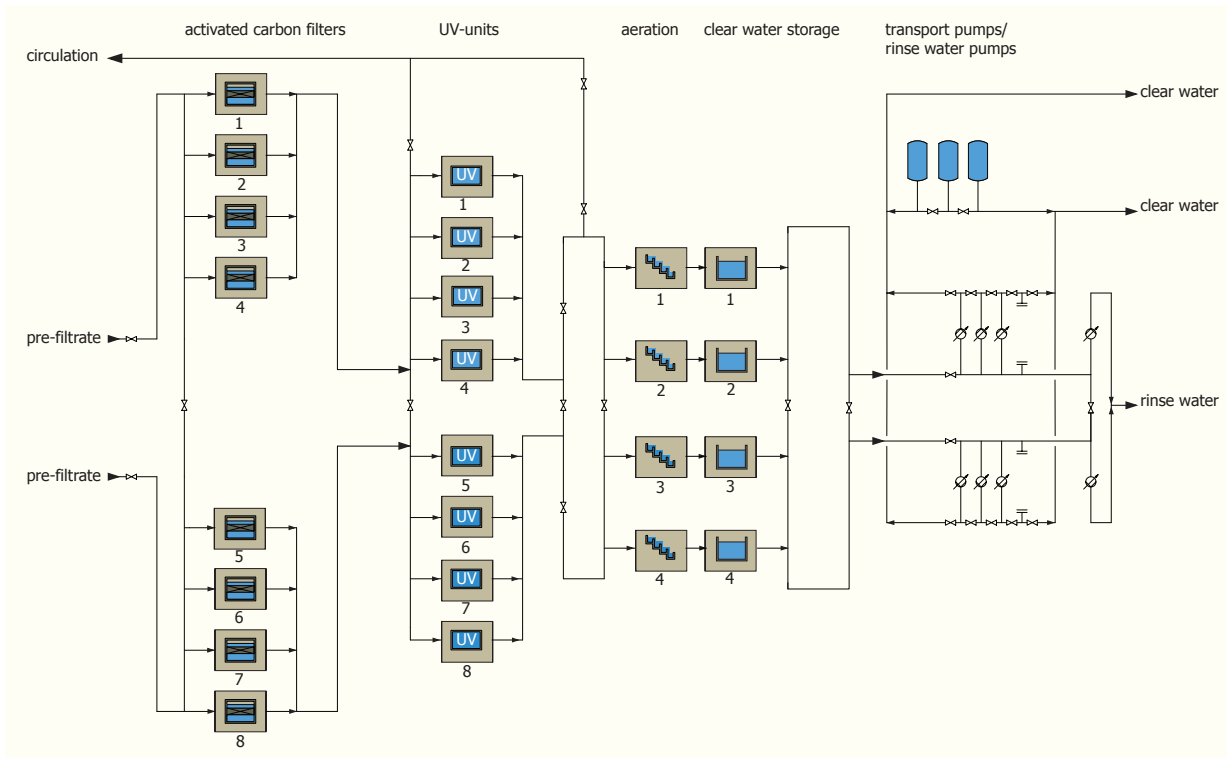

Figure 33 - A part of the process flow diagram (Main water flow diagram)

Architecture

Adjustment of the design because of architectural considerations may be desirable. Therefore, it is useful to indicate the functional relationships between the different components. This will give a better indication to the architect of the degrees of freedom and of the consequences of breaking them (Figures 36 and 37).

7.4 Final design and detailed design

During the final design and detailed design phases, many more design documents are still formulated.

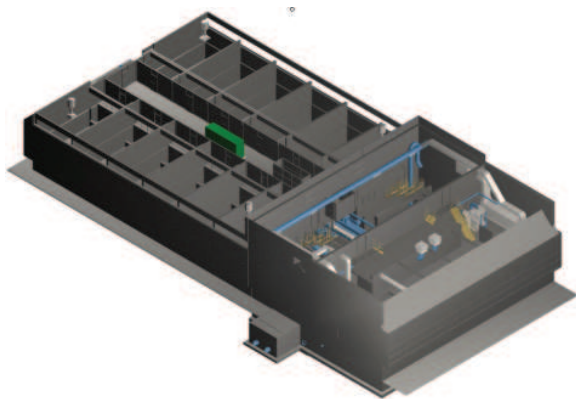

Figure 34 - Design of building

Here, only the piping and instrument diagram is considered.

Piping and instrument diagram (P&ID)

The piping and instrument diagram (P&ID) (ISO 10628) indicates the technical construction of a process through standardized symbols for installations, pipes, instruments and control systems. The minimum information in such diagram includes the following:

- function or type of apparatus, including drives and installed spare parts

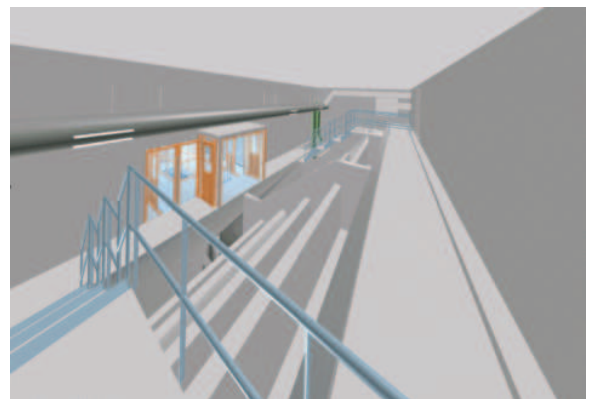

Figure 35 - Design cascade aeration

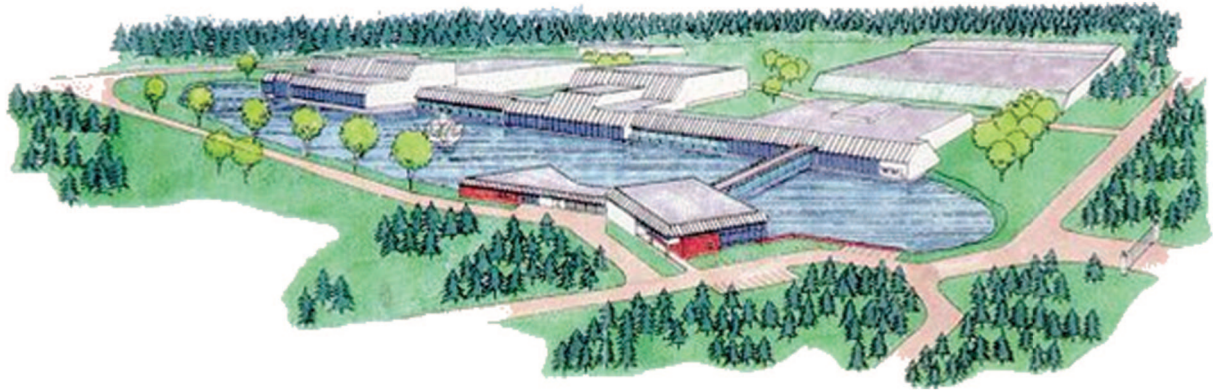

Figure 36- Architectural design drawings

- identification number of apparatus including drives and installed spare parts
- characteristic data of apparatus (on a separate list)
- identification of nominal diameter, pressure class, piping material and classification
- details of installations, pipes, gauges and junctions
- process measurement installations and control systems with identification
- characteristic data of drivers

7.5 Construction and start-up

Even during the construction phase, several design activities are performed. These may include a further detailed elaboration of the design (i.e., form and reinforcement drawings) or temporary constructions (dam walls, concrete molds).



Figure 37 - An architect's scale model

