

# EARTHING SYSTEM & PROTECTION IN LOW VOLTAGE INSTALLATIONS

**VOL.1: BASICS OF LV EARTHING SYSTEM**



**END USER: RAILWAY ELECTRICAL ENGINEERS AND TECHNICIANS DEALING WITH LV INSTALLATIONS**

**CAMTECH/ EL/ 2020-21/ Earthing-Vol.1/ 1.0**

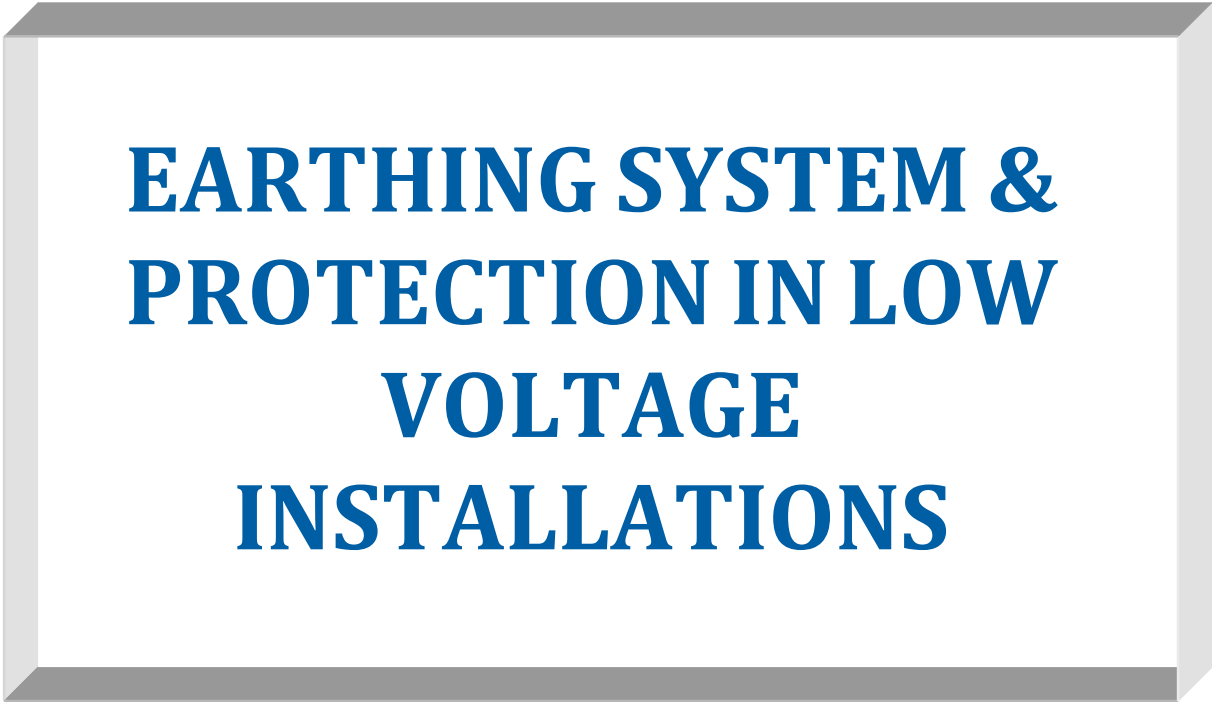
**March 2021**

**अभ्यास RDS**  
रेल अग्रदूत Transforming Railways



**Indian Railways  
Centre for Advanced Maintenance Technology**

**Maharajpura, GWALIOR - 474 005**



**EARTHING SYSTEM &  
PROTECTION IN LOW  
VOLTAGE  
INSTALLATIONS**

**VOL.1: BASICS OF LV EARTHING SYSTEM**

## **QUALITY POLICY**

“We at RDSO, Lucknow are committed to maintain and update transparent standards of services to develop safe, modern and cost effective railway technology complying with statutory and regulatory requirements, through excellence in research, designs and standards by setting quality objectives, commitment to satisfy applicable requirements and continual improvements of the quality management system to cater to growing needs, demand and expectations of passenger and freight traffic on the railways through periodic review of quality management systems to achieve continual improvement and customer appreciation. It is communicated and applied within the organization and making it available to all the relevant interested parties.”



## उच्च अनुरक्षण प्रौद्योगिकी केन्द्र

रेल मंत्रालय

डी.डी. नगर, महाराजपुर, ग्वालियर-474005

(आई.एस.ओ. 9001-2015 प्रमाणित संस्थान)



### CENTRE FOR ADVANCED MAINTENANCE TECHNOLOGY

Ministry of Railways

DD Nagar, Maharajpur, Gwalior - 474005

(ISO 9001-2015 Certified Organisation)

जितेन्द्र सिंह आई आर एस एमई

Jitendra Singh IRSME

प्रधान कार्यकारी निदेशक

Principal Executive Director

## FOREWORD

Use of electricity in day-to-day living is an integral part of everyone's life. Since unintended exposure to electricity is life threatening, provision of proper earthing is essential for any electrical wiring and installation. Most of us treat earth electrode as solution of safety from unintended exposure to electricity which is just not the case. There are also so many myths and misconception about earthing and earthing systems. To ensure safety of life and apparatus against earth faults, it is necessary to provide proper earth connection to equipotential bonding along with other suitable protection devices to disconnect the electric supply within the stipulated time. For understanding these concepts, the electrical engineers and technicians shall be familiar to correct code and practices.

To break the myths about earthing and to ensure wide dissemination of knowledge on correct practices about earthing in LT installations, this **volume-1 on "Basics of Earthing System"** under the document "**Earthing System and Protection in Low Voltage Installations**" has been prepared by CAMTECH, Gwalior.

This volume-1 covers common myths and facts along with detailed explanations. This also contains relevant terms, circuits of earthing systems (like TN, TT, IT), effect of electric shock on human body, IE/ CEAR rules/ regulations pertaining to earthing, etc.

I am sure that this booklet will be useful for electrical design and maintenance engineers and technicians for updating their knowledge, improving the reliability and safety of electrical installations as well as precious human lives. This will be also helpful in reducing the electrical failures on account of earth faults.



**Jitendra Singh**  
**Principal Executive Director**

---

### Research Design and Standard Organisation

Annexe-II Building, Ground Floor, Manak Nagar, Lucknow, India 226011  
Phone & Fax : 0522-2462445, Rly : 4070, 9752447000, edcamtech@gmail.com

## PREFACE

The “*code of practice for earthing of power supply installations for 25kV single phase traction system*” is covered in Appendix-III of ACTM Vol-II, Part-II. It is important to note that Low voltage (LT) electrical power distribution system does not come under the purview of this code. (As per para-1 of the appendix-III).

There are Indian Standards and regulations on earthing and earthing system which are neglected and misinterpreted at many places during design and commissioning of system. There is no other standard document for LT earthing on I.R..Railway Board therefore, advised CAMTECH, Gwalior to study the subject in details and address the common myths about LT earthing in the publication to disseminate the knowledge among the electrical engineers and technicians about correct practices of earthing system.

The word “earth” and “earthing” is misunderstood as an electrode in soil and similarly there are so many Myths and misconceptions related to earthing and earthing system which are deeply incorporated as wrong practices in the regular working systems. The earth connection improves service continuity and avoids damage to equipment and danger to human life. It also reduces the risk of a person in the vicinity of earthed facilities being exposed to the danger of critical electric shock. The object of earthing is to ensure safety of life and apparatus against earth faults

This volume-1 on “**Basics of LV Earthing System**” under the document “**Earthing System and Protection in Low Voltage Installations**” has been prepared by CAMTECH, Gwalior with the intention to spread awareness on myths and facts about earthing in LV installations, types of System earthing, Equipotential bonding and other terms related to LV installations to all those who are concerned with the design, installation, inspection and maintenance of electrical systems and apparatus.

Technological up-gradation & learning is a continuous process. Please feel free to write to us for any addition/ modification in this booklet. We shall highly appreciate your contribution in this direction.



Himanshu Maheshwari  
Dy. Director /Electrical

## ACKNOWLEDGEMENT

I would like to express my sincere gratitude to Shri Jitendra Singh, PED/CAMTECH for the continuous support, guidance & motivation in making of this publication.

I would like to thank Shri Manish Gupta, ED/EEM/Railway Board for his continuous encouragement, direction, support and guidance during in making of this publication.

My sincere thanks to Shri Vivek Dixit, CEGE/Central Railway for his continuous motivation, guidance, suggestions, insightful comments, and hard questions which guided us to make this publication more simpler for users to understand.

My sincere thanks to Shri S Gopa Kumar, Member in various Electrotechnical committees of BIS for his technical guidance and support throughout the process of making this publication. He has helped us in understanding the Indian and international standards, various concepts of earthings, comments and clearing our doubts which we faced during the making of this publications.

I thank my team members Shri B. C. Agrawal SSE/EL/CAMTECH & Smt. Sangeeta Shrivastava JE/IT/CAMTECH for their continuous study, hardwork, sincere efforts & dedication to make this publication.



*Himanshu Maheshwari*  
*Dy. Director /Electrical*

## CONTENTS

<i>Description</i>	<i>Page No.</i>
FOREWORD .....	iv
PREFACE .....	v
ACKNOWLEDGEMENT .....	vi
CONTENTS .....	iv
LIST OF FIGURES .....	ix
LIST OF TABLES .....	x
ISSUE OF CORRECTION SLIP .....	xi
DISCLAIMER .....	xii
OBJECTIVE OF PUBLICATION .....	xii
ABBREVIATIONS .....	xiii
1.0 MYTHS AND FACTS ABOUT EARTHING .....	1
1.1 <i>Myth-1: “Earth, Earthing and Earth Electrode, all these 3 words convey the same meaning.”</i> .....	1
1.2 <i>Myth-2: “Only Connecting exposed conductive part of an electrical equipment to the earth electrode in soil will protect against electric shock”</i> .....	1
1.3 <i>Myth-3: “When earth fault occurs the fault current goes into the earth and natural earth serves as a return path for fault current”</i> .....	2
1.4 <i>Myth-4: “Entire fault current will always flow through least resistance path”</i> .....	3
1.5 <i>Myth-5: ‘Grounding’ implies connection of current carrying parts to Earth, like transformer or generator neutral and ‘Earthing’ implies connection of non-current carrying parts to Earth, like metallic enclosures”</i> .....	3
1.6 <i>Myth-6: “The more earth electrodes in soil (Separate equipment earth electrode), the better system”</i> .....	3
1.7 <i>Myth-7: “Copper Earth Electrodes are better than GI or Steel Earth Electrodes”</i> .....	4
1.8 <i>Myth-8: “Plate Earthing is better than Pipe Earthing as it offers less resistance”</i> .....	5
1.9 <i>Myth-9: “Deeper the earth pit and longer the earth pipe/rod, lesser will be the resistance”</i> .....	6
1.10 <i>Myth-10: Adding more water will result in less resistance of earth pit.</i>	7
1.11 <i>Myth-11: Adding more salt will result in less resistance of Earth.</i> .....	7
1.12 <i>Myth 12: Only high voltage lines pose a fatal danger and low voltage i.e. 240V AC domestic supply is not fatal.</i> .....	8

1.13	<i>Myth 13: All Rubber shoes/Sleepers/gloves can protect from electric shock.</i>	9
1.14	<i>Myth 14: Wood is an insulator and wooden ladders cannot conduct electricity.</i>	9
1.15	<i>Myth 15: Neutral&amp; body of every transformer/DG and the metallic parts not intended as conductors each requires two separate and distinct connections to earth electrodes in soil.</i>	9
2.0	PURPOSE OF EARTHING	12
3.0	EARTHED AND UNEARTHED SYSTEMS	12
4.0	EQUIPMENT EARTHING	13
4.1	Earthing of Equipment using Current	13
4.2	Voltage Exposure	14
4.2.1	Avoidance of Thermal Distress	14
4.2.2	Preservation of System Performance	14
4.2.3	Earthing & Protective Conductor	14
5.0	SYSTEMEARTHING	15
6.0	TYPES OF SYSTEM EARTHING	16
6.1	TN System	17
6.1.1	TN-S System	17
6.1.2	TN-C System	18
6.1.3	TN-C-S System	19
6.2	TT System	20
6.3	IT System	21
7.0	EQUIPOTENTIAL BONDING	22
7.1	Protective Equipotential Bonding	23
7.2	Supplementary Equipotential Bonding	23
7.3	Main Earthing Terminal (MET)	24
7.4	Typical Schematic of Earthing and Protective Conductors	25
7.5	Extraneous Conductive Parts	26
	(Ref IS 3043:2018 para 23.2.3 )	26
7.6	Exposed Conductive Parts	26
	(Ref IS 3043:2018 para 23.2.4)	26
7.6.1	Exposed conductive parts not required to be earthed	26
8.0	EARTH FAULT PROTECTION IN LV INSTALLATIONS	27
8.1	Protection against Indirect Contact	28
8.2	Earthed Equipotential Bonding and Automatic Disconnection of the Supply	29
8.2.1	Disconnecting Times for Different Touch Voltages	30
8.3	Requirement for Automatic disconnection in TN System	30



8.4	Requirement for Automatic disconnection in TT System .....	31
8.5	Requirement for Automatic disconnection in IT System .....	31
9.0	EARTH FAULT LOOP IMPEDANCE .....	31
9.1	Fault Loop in TN-S System.....	32
9.2	Fault Loop in TN-C System .....	32
9.3	Fault Loop in TN-C-S System.....	33
9.4	For TT System .....	33
10.0	EARTHING OF INSTALLATIONS .....	34
10.1	Earthing in Standby Generating Plants (Ref - IS 3043:2018 para 29) .....	34
10.1.1	Unearthed Generators (Rating Below 10 kW) Supplying a Fixed Installation .....	34
10.2	Unearthed Generators Supplying a Mobile or Transportable Unit.....	35
10.3	Earthing in Building .....	36
11.0	EARTH ELECTRODES .....	38
11.1	Effect of Shape on Electrode Resistance .....	38
11.2	Multiple Earth Electrodes .....	38
11.3	Common Types of Earth Electrodes.....	39
11.3.1	Plate electrode .....	39
11.3.2	Pipes or Rods electrode .....	39
11.3.3	Artificial treatment of soil .....	42
11.3.4	Strip or Conductor Electrodes .....	42
11.4	Other Means of Earthing .....	43
11.4.1	Cable Sheaths .....	43
11.4.2	Structural Steelwork as Earth Electrodes .....	43
11.4.3	Reinforcement of Piles .....	44
11.4.4	Water Pipes.....	44
11.5	Connections to Earth Electrodes.....	44
12.0	EARTHING SYMBOLS .....	45
13.0	VOLTAGE GRADIENT AROUND EARTH ELECTRODES .....	46
14.0	CURRENT DENSITY AT THE SURFACE OF EARTH ELECTRODE .....	46
15.0	BASICS OF ELECTRIC CIRCUIT .....	47
15.1	Simple Open and Closed Circuit .....	47
15.2	Open and Closed Circuit with Earth.....	47
16.0	ELECTRIC SHOCK .....	48
16.1	Range of Tolerable Current .....	48
16.2	Effect of Frequency .....	49
16.3	Effect of Magnitude and Duration of Current Passing through Body .....	49

16.4 Resistance of Human Body .....	49
ANNEXURE-I.....	51
EARTHING TERMINOLOGY .....	51
(Ref IS 3043:2018 & IS 732:2019).....	51
i. Arc-Suppression Coil (Peterson Coil) .....	51
ii. Bonding Conductor .....	51
iii. Class 0 Equipment .....	51
iv. Class I Equipment.....	51
v. Class II Equipment .....	51
vi. Class III Equipment .....	51
vii. Principal Characteristics of Equipment and Precautions for Safety.....	51
viii. Dead	52
ix. Double Insulation .....	52
x. Reference Earth .....	52
xi. Earthing System.....	52
xii. Global Earthing System.....	52
xiii. Earth Electrode .....	52
xiv. Earth Grid .....	52
xv. Earth Electrode Resistance .....	52
xvi. Earth Fault Loop Impedance .....	52
xvii. Earth Leakage Current.....	52
xviii. Earthed Concentric Wiring.....	53
xix. Earthing Conductor .....	53
xx. Electrically Independent Earth Electrodes .....	53
xxi. Equipotential Bonding .....	53
xxii. Exposed Conductive Part .....	53
xxiii. Extraneous Conductive Part .....	53
xxiv. Final Circuit.....	53
xxv. Functional Earthing .....	53
xxvi. Live Part .....	53
xxvii. Main Earthing Terminal .....	53
xxviii. Neutral Conductor .....	54
xxix. PEN Conductor.....	54
xxx. Portable Equipment .....	54
xxxi. Potential Gradient (At a Point).....	54
xxxii. Earth Potential .....	54
xxxiii. Earth Potential Rise .....	54

xxxiv. Hot Site .....	54
xxxv. Transferred Potential .....	54
xxxvi. Protective Conductor .....	54
xxxvii. Reinforced Insulation .....	55
xxxviii. Residual Current Device.....	55
xxxix. Residual Operating Current.....	55
xl. Resistance Area (for an Earth Electrode only) .....	55
xli. Simultaneously Accessible Parts .....	55
xlii. Supplementary Insulation .....	55
xliii. Switchgear .....	55
xliv. Voltage, Nominal .....	55
xlv. Touch Voltage .....	55
xlvi. Prospective Touch Voltage.....	56
xlvii. Step Voltage .....	57
xlviii. Equipotential Line or Contour .....	57
xlix. Mutual Resistance of Earthing Electrodes .....	57
l. Earth Grid .....	57
li. Earth Mat .....	57
REFERENCES .....	58

## LIST OF FIGURES

<i>Description</i>	<i>Page No.</i>
Figure 1: Effect of Length of Pipe Electrode on Calculated Resistance for Soil Resistivity of 100Ωm (Assumed uniform).....	6
Figure 2: Variation of Soil Resistivity with Moisture Content .....	7
Figure 3: Variation of Soil Resistivity with Salt (NaCl) Content, Clay Soil Having 3 Percent Moisture.....	8
Figure 4: Wrong practice of connecting every appliance to two separate earth electrodes. ....	9
Figure 5: Wrong practices of separate earth electrodes in soil .....	11
Figure 6: Right practice of Earthing.....	11
Figure 7: Marking of Earth Conductors .....	15
Figure 8: Indicative supply system based on system earthing .....	16
Figure 9: TN-S System.....	17
Figure 10: TN-S System for 230V Single Phase .....	17
Figure 11: TN-S System for 415 V three-phase domestic commercial supply.....	18
Figure 12: TN-C System .....	18
Figure 13: Neutral breakage in TN-C System.....	19
Figure 14: TN-C-S System.....	19
Figure 15: Multiple Earthing of PEN Conductor in TN-C-S System .....	20
Figure 16: TT System.....	21
Figure 17: IT System.....	21
Figure 18: Equipotential bonding with all exposed/extraneous conductive parts.....	22
Figure 19: Equipotential Bonding with all exposed/extraneous conductive parts.....	23
Figure 20: Equipotential Bonding with Supplementary Bonding.....	24
Figure 21: Main Earthing Terminal (MET) .....	24
Figure 22: Earthing Arrangements and Protective Conductors .....	25
Figure 23: Indirect Contact in case of earth fault.....	27
Figure 24: A Non Conductive Location.....	28
Figure 25: Fault loop impedance circuit in TN-S system .....	32
Figure 26: Fault loop impedance circuit in TN-C system.....	32
Figure 27: Fault loop impedance circuit in TN-C-S system .....	33
Figure 28: Fault loop impedance circuit in TT system .....	33
Figure 29: Single Low Voltage Standby Generator (Without paralleling Facility).....	34
Figure 30: Small low voltage generator supplying a fixed installation .....	35
Figure 31: Small unearthed generator supplying a mobile or transportable unit.....	36
Figure 32: Example of Earthing Arrangements and Protective Conductors.....	37

Figure 33:	Sphere of Influence Earth Electrode.....	38
Figure 34:	Spheres of Multiple Earth Electrodes.....	38
Figure 35:	Copper Plate Electrode.....	39
Figure 36:	Pipe Electrode.....	40
Figure 37:	Copper Bonded Steel rod Electrode.....	40
Figure 38:	Typical arrangement of pipe electrode (Ref fig 25 of IS 3043:2018).....	41
Figure 39:	Effect of Length of Strip or Conductor Electrodes In Calculated Resistance For Soil Resistivity Of 100 $\Omega$ M (Assumed Uniform).....	43
Figure 40:	Earthing of Foundation Reinforcement.....	44
Figure 41:	Incomplete circuit or open circuit, no current will flow in above condition. ....	47
Figure 42:	Complete circuit or close circuit, current will flow in this condition according to the source voltage and load resistance.....	47
Figure 43:	Incomplete circuit or open circuit, no current will flow in above condition. ....	48
Figure 44:	Complete circuit or close circuit, current will flow in this condition according to the source voltage and circuit resistance. ....	48
Figure 45:	Illustration of body resistance for different part.....	50
Figure 46:	Step and Touch Voltages.....	56

## LIST OF TABLES

<i>Description</i>	<i>Page No.</i>
Table 1: Comparison between Earthed and Unearthed System.....	12
Table 2: Disconnecting Times for Different Touch Voltages.....	30
Table 3 : Effect of Magnitude and Duration of Current Passing through Body.....	49
Table 4: Equipment Characteristics and Safety Precautions.....	51



## DISCLAIMER

*It is clarified that the information given in this booklet does not supersede any existing provisions of Indian Standards (IS) on the subject, related matters, and other existing provisions laid down by the Railway Board, RDSO. This is not a statutory document and instructions given are for the purpose of guidance only. If at any point contradiction is observed, then Indian Standards, regulations issued by Government bodies, Railway Board/RDSO guidelines shall be referred.*

## OBJECTIVE OF PUBLICATION

*To prepare guidelines which can educate the IR engineers and Technicians dealing with Low voltage electrical installations and other IR officials about various provisions given in IS standards pertaining to IS 3043-2018, IS 732:2019.*

## ABBREVIATIONS

<i>Abbreviation</i>	<i>Full Form</i>
<b>AC</b>	Alternating Current
<b>CEA</b>	Central Electricity Authority
<b>CEAR</b>	Central Electricity Authority Regulations
<b>CNE</b>	Combined Neutral and Earth
<b>DB</b>	Distribution Board
<b>DC</b>	Direct Current
<b>EE</b>	Earth electrode
<b>ELCB</b>	Earth leakage Circuit Breaker
<b>IE</b>	Indian Electricity
<b>IEC</b>	International Electro-technical Commission
<b>IS</b>	Indian Standard
<b>LPS</b>	Lightning Protection System
<b>MDB</b>	Main Distribution Board
<b>MET</b>	Main Earthing Terminal
<b>N</b>	Neutral
<b>OCPD</b>	Over Current Protective Device
<b>PEN</b>	Neutral and Protective conductor combined
<b>PME</b>	Protective Multiple Earthed
<b>PNB</b>	Protective Neutral Bonding
<b>RCD</b>	Residual Current Device
<b>SEBT</b>	Supplementary Equipotential Bonding Terminal
<b>SPD</b>	Surge Protection Device
<b>T</b>	Terre (French word for earth)



## 1.0 MYTHS AND FACTS ABOUT EARTHING

It is generally observed that there are several myths and perceptions about earthing in the minds of IR personnel dealing with low voltage electrical installations, which are either not true or partially true. Therefore, some of the commonly noticed myths have been enumerated below these myths have then been discussed with the facts in a summarised way. The other pertaining points have been covered in various other chapters.

### 1.1 **Myth-1: “Earth, Earthing and Earth Electrode, all these 3 words convey the same meaning.**

#### **Fact: Not True**

The earth, earthing and earth electrodes convey different meaning, earth is general mass of mother earth while earth electrode is an independent system provided to give electrical connection to mother earth (soil). The Earthing is an elaborate network to connect all exposed conductive parts of any equipment/installation to earth potential through MET (Main Earthing Terminal). Incidentally, definitions given in Indian Standard (IS) are summarized below:

*“Earth means the conductive mass of the earth, whose electric potential at any point is conventionally taken as zero”.*(Ref.: Para no. 3.60 of IS 732:2019)

*“Earthing means connection of the exposed conductive parts of an installation to the Main Earthing Terminal (MET) of that installation”.*(Ref.: Para no. 3.66 of IS 732:2019)

*“Earth Electrode means a conductor or group of conductors in intimate contact with and providing an electrical connection to earth.* (Ref.: Para no. 3.7 of IS 3043:2018)

They can include rods, plate, strip, steel reinforcing bars, sheaths of cables etc.”.

**MET**(Main Earthing Terminal):- *The terminal or bar (which is the equipotential bonding conductor) provided for the connection of protective conductors and the conductors of functional earthing, if any, to the means of earthing.* (Ref.: Para no. 3.21 of IS 3043:2018).

**Exposed conductive part:-** *A conductive part of equipment which can be touched and which is not alive part but which may become live under fault conditions. Like panel Body.* (Ref.: Para no. 3.16 of IS 3043:2018).

### 1.2 **Myth-2: “Only Connecting exposed conductive part of an electrical equipment to the earth electrode in soil will protect against electric shock”.**

**Myth Explanation:** - In general household/commercial wiring the earth wire is also running along with phase and neutral wires. The conductive exposed part/body of electrical equipment which is connected to earth through the earth wire and further earth wire is connected to the earth electrode. It is pre-assumed that if there is any earth fault happens through contact of phase/live conductor to the conductive exposed part/body of the equipment/installation, the earth fault current will flow through the earth wire to earth electrode then to earth mass/back to the source (Transformer/Generator) and this way protective device (Fuse, MCB, etc.) will operate and protect person from the electric shock.

**Fact: Not true****Protective equipotential bonding and automatic disconnection of supply with in permissible time can only prevent electric shock.**

It is a very common myth that system is healthy if connected to earth electrode with least earth pit resistance but this may not be true in practical condition every time to have a low resistance earth pits such that fault current magnitude can cause tripping of OCPD (Over Current Protective Device) within permissible time. Because of this reason only connection of exposed conductive parts of electrical equipment to earth electrode in soil will not protect from an electric shock.

Protective **equipotential bonding**<sup>1</sup> that is connecting of the exposed conductive parts and extraneous conductive parts with Main Earthing Terminal. Whenever earth faults occur a voltage will appear between the exposed conductive parts and extraneous conductive parts in the location served by the installation concerned, but the application of protective equipotential bonding minimizes these touch voltage reaches a harmful value.

In case of earth fault if the fault current is less than the rated breaking current of protective device (OCPD like MCB), then it will not trip. The automatic disconnection of supply system should be designed considering **fault loop impedance**<sup>2</sup>, which is the impedance/resistance encountered by current under fault condition i.e. impedance/resistance from fault point to neutral point of the source (Transformer/generator) shall be such that it will disconnect the supply to faulty equipment by detection of fault current and leakage current through use of suitably rated OCPD (Over Current Protective Device like fuse, MCB, etc.) and RCD (Residual Current Device like RCCB) within stipulated time.

### 1.3 **Myth-3: “When earth fault occurs the fault current goes into the earth and natural earth serves as a return path for fault current”.**

**Fact: Partially True**

As a Fact, **Current will always return back to its source (Transformer/generator).** In any electrical system, during earth fault, the fault current will not get absorbed into the earth and it will go back to the source only either via return conductor or through mother earth.

In case of earth fault, the fault current will flow back to the source through the return conductor (protective earth & neutral conductor) in case of TN-C-S system. As IS 3043:2018 stipulates several types of earthing systems like TN(TN-S, TN-C, TN-C-S) TT, & IT in which TN-C-S is most common earthing system used in India for LV installations as mandated under statutory provisions in para-4 of IS 3043:2018, other than some specialized requirements. **Types of earthing systems**<sup>3</sup> are further explained in detail in this booklet.

As per IS 3043-2018 para 4 of foreword, “*the earth now rarely serves as a part of the return circuit but is being used mainly for fixing the voltage of system neutrals*”. It is important to note that natural earth is a very poor conductor of electric current. The

---

<sup>1</sup>Refer to para 7.0 of this booklet

<sup>2</sup>Refer to para 9.0 of this booklet

<sup>3</sup>Refer to para 6.0 of this booklet

typical resistivity of the general mass of earth is about 100 Ohm-m. Compare this with the resistivity of Copper, which is,  $1.7 \times 10^{-8}$  Ohm-m ( $0.017 \text{ Ohm-mm}^2/\text{m}$ ) and that of GI, which is,  $1 \times 10^{-7}$  Ohm-m ( $0.1 \text{ Ohm-mm}^2/\text{m}$ ). **This shows that, natural earth is much more resistive than Copper or GI.**

The purpose of earth connection is to improve service continuity and to avoid damage to equipment and danger to human life.

**1.4 Myth-4: “Entire fault current will always flow through least resistance path”.**

**Fact: Partially true**

Current does not only take the path of least resistance. Current will flow through all possible closed paths back to its source, only the magnitude of current will depend on the impedance of that particular closed path. For a lower impedance path, current will be higher compared to a higher impedance path.

**1.5 Myth-5: ‘Grounding’ implies connection of current carrying parts to Earth, like transformer or generator neutral and ‘Earthing’ implies connection of non-current carrying parts to Earth, like metallic enclosures”.**

**Fact: Not true.**

**Earthing and Grounding are synonym to each other.**

- The terms ‘earthing’ and ‘grounding’ are used synonymously. This is also mentioned in para8 of ‘Foreword’ of IS 3043-2018.
- The different nomenclature is due to the usual conflicting usage of English language between the Americans & the British.
- British termed it as ‘earthing’, while the Americans termed it as ‘grounding’. IEC & IS Standards referring as ‘earthing’, while IEEE & ANSI Standards referring as ‘grounding’.

**1.6 Myth-6: “The more earth electrodes in soil (Separate equipment earth electrode), the better system”.**

**Fact: Not true.**

**More earth electrodes in soil i.e. separate earth electrode for each equipment, can cause more problems than it solves.** Adding more earth electrodes in soil can actually expose the equipment/building to current from nearby lightning strikes or fault in Electrical power system of utilities and this may cause equipment failure by providing a path for that high magnitude current spike to travel through electrical and electronics equipment. Separate earth electrode for individual equipment is a misconception which is explained **in detail in 1.15.**

When lightning strike happens, there is rise in earth potential near an electrode in that area, and that may provide an additional path between earth electrodes and earth conductors for lightening/fault current to travel through the equipment which may damage equipment. This may be avoided by connecting earthing of all equipment

through protective earth conductor to Main Earthing Terminal. which is further connected to the earth electrode/return conductor depending on type of earthing system.

### 1.7 **Myth-7:“Copper Earth Electrodes are better than GI or Steel Earth Electrodes”.**

**Fact: Not true.**

**The type of Metal used has no significance on the earth electrode resistance.**

- If we, consider a **plate electrode**, according to Cl. 14.2.1 of IS3043-2018, the approximate resistance to earth of a plate can be calculated from:

$$R = \frac{\rho}{4} \sqrt{\frac{\pi}{A}} \Omega$$

where

$\rho$  = resistivity of the soil in  $\Omega$ -m (assumed uniform), and  
 $A$  = area of both sides of the plate (in  $m^2$ ).

- Similarly, for **Rod or Pipe Electrodes**, according to Cl. 14.2.2 of IS3043-2018, the resistance of a pipe or rod electrode is given by:

$$R = \frac{100\rho}{2\pi l} \log_e \frac{2l}{d} \Omega$$

Where,

$\rho$  = resistivity of the soil, in  $\Omega$ -m (assumed uniform).

$l$  = length of rod or pipe, in cm,

$d$  = diameter of rod or pipe, in cm, and

- And, for **Strip or Conductor Electrodes**, according to Cl. 14.2.3 of IS3043-2018, the resistance of a strip or conductor electrode is given by:

$$R = \frac{100\rho}{2\pi l} \log_e \frac{4l}{d} \Omega$$

where,

$\rho$  = resistivity of the soil, in  $\Omega$ -m (assumed uniform),

$l$  = length of the Strip in cm, and

$d$  = width (strip) or twice the diameter (conductors) in cm.

As can be seen from the above formulae, only the resistivity of the soil and the physical dimensions of the electrode play a major role in determining the electrode resistance to earth. The material resistivity is not considered anywhere in the above formulae. Hence, irrespective of the material of construction of the earth electrode, any material of given dimensions would offer the same resistance to earth.

However, in highly corrosive areas, it is recommended to use Cu or Cu coated electrodes which have better resistance to corrosion as compared to GI/Steel electrode.

### 1.8 **Myth-8:“Plate Earthing is better than Pipe Earthing as it offers less resistance”.**

**Fact: Not true.**

**A pipe, rod or strip has a much lower resistance than a plate of equal surface area.**

- It is common believe that plate earthing is better over Pipe or Rod or Strip Earthing because more surface area means less resistance.

$$R = \frac{\rho L}{A}$$

where,

- $\rho$  = resistivity of the conductor material in  $\Omega$ -m,
- $l$  = length in m, and
- $A$  = cross sectional area  $m^2$ .

But this is not correct formula to calculate earth electrode resistance.

To examine this, let us consider a **plate** electrode of size **60 cm x 60 cm x 3.15mm thick**. Assuming a soil resistivity of 100 Ohm-m, the resistance of this electrode to earth as per following formula,

$$R = \frac{\rho}{4} \sqrt{\frac{\pi}{A}} \Omega$$

$$R = \frac{100}{4} \times \sqrt{\frac{3.14}{0.6 \times 0.6 + 0.6 \times 0.6}}$$

$$R = 52.21 \Omega$$

Now, consider a **Pipe Electrode** of **50 mm Diameter** and **400 cm Long**. Assuming a soil resistivity of 100 Ohm-m, the resistance of this electrode as per following formula to earth:

$$R = \frac{100\rho}{2\pi l} \log_e \frac{2l}{d} \Omega$$

$$R = \frac{100 \times 100}{2 \times 3.14 \times 400} \log_e \frac{2 \times 400}{5}$$

$$R = 20.20 \Omega$$

As can be seen from the above calculation the **Pipe electrode (surface area 0.63 m<sup>2</sup>)** offers a much lesser resistance than even a **plate electrode of more surface area (0.72 m<sup>2</sup>)**.

*IS 3043-2018 also acknowledges this fact vide Cl. 14.1, wherein it states that ‘a pipe, rod or strip has a much lower resistance than a plate of equal surface area. The resistance is not, however, inversely proportional to the surface area of the electrode.*

However for higher current density requirements plate earthing may be preferred over pipe/rod earthing.

**1.9 Myth-9: “Deeper the earth pit and longer the earth pipe/rod, lesser will be the resistance”.**

**Fact: Partially True**

As stated in Cl. No. 14.2.2 of IS 3043-2018, “that the resistance to earth of a pipe or rod electrode diminishes rapidly with the first few feet of driving, but less so at depths greater than 2 to 3 m in soil of uniform resistivity”.

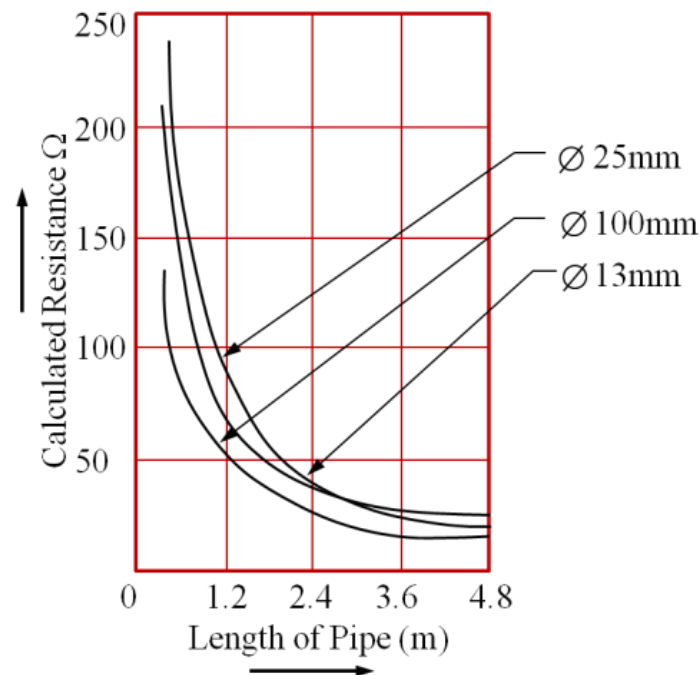


Figure 1: Effect of Length of Pipe Electrode on Calculated Resistance for Soil Resistivity of  $100\Omega\text{m}$  (Assumed uniform)

As can be seen from the graph given above (Cl. No. 14.2.2 of IS 3043-2018), after about 4m depth, there is no appreciable change in resistance to earth of the electrode.

Number of rods/ pipes in parallel are to be preferred to a single long rod/pipe. When a number of rods/ pipes are connected in parallel, the resistance is practically proportional to the reciprocal of the number of electrode connected, provided each electrode is situated outside the resistance area of any other electrode.

Deeply driven rods are, however, effective where the soil resistivity decreases with depth or where substrata of low resistivity occur at depths greater than those with rods, for economic reasons, are normally driven.



☞ The earth electrode resistance value from a 4 meters long earth electrode cannot be replaced by using two electrodes connected in parallel each of 2 meters length (considering uniform soil resistivity)

### 1.10 **Myth-10: Adding more water will result in less resistance of earth pit.**

#### **Fact: Partially true**

The resistance to earth of a given earth electrode depends upon the electrical resistivity of the soil in which it is installed. Moisture content is one of the controlling factors of earth resistivity.

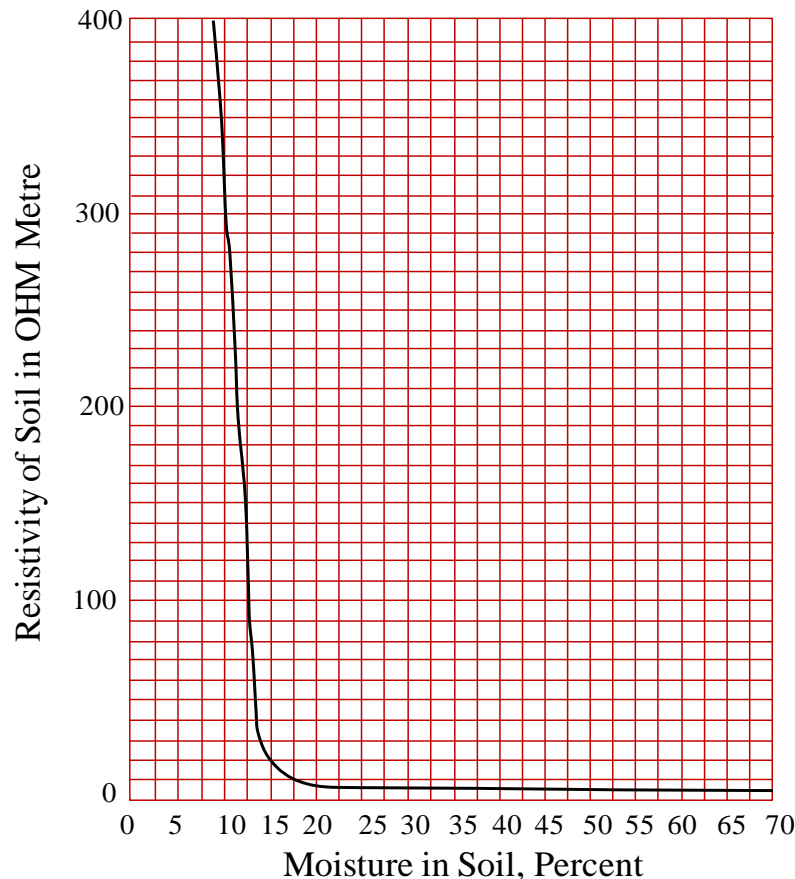


Figure 2: Variation of Soil Resistivity with Moisture Content

As can be seen from the above graph (Cl. No. 13.6, fig 19 of IS 3043-2018), that above 20 percent moisture content, the resistivity is very little affected. Below 20 percent, the resistivity increases abruptly with the decrease in moisture content. If the moisture content is already above 20 percent, there is no point in adding barrels of water into the earth pit as this may not help in change in resistance of earth electrode.

### 1.11 **Myth-11: Adding more salt will result in less resistance of Earth.**

#### **Fact: Partially True**

As a traditional practice whenever an earth pit is commissioned a homogenous layer of coke/charcoal, salt is added surrounding the electrode as per figure 14 of IS 3043:1987. But now As per latest guidelines of IS 3043:2018 figure no. 25 (Figure 38 of this booklet), only homogenous layer of common earth is to be used. However earth enhancing material may be used where soil resistivity is high.

As a common practice, during maintenance of earth pits in order to reduce the earth electrode resistance more salt is added in the pit in a belief that it will reduce the earth electrode resistance drastically.

The reduction in soil resistivity effected by the salt content is shown in the curve given below (Cl. No. 13.8.3 fig-20 of IS 3043-2018)

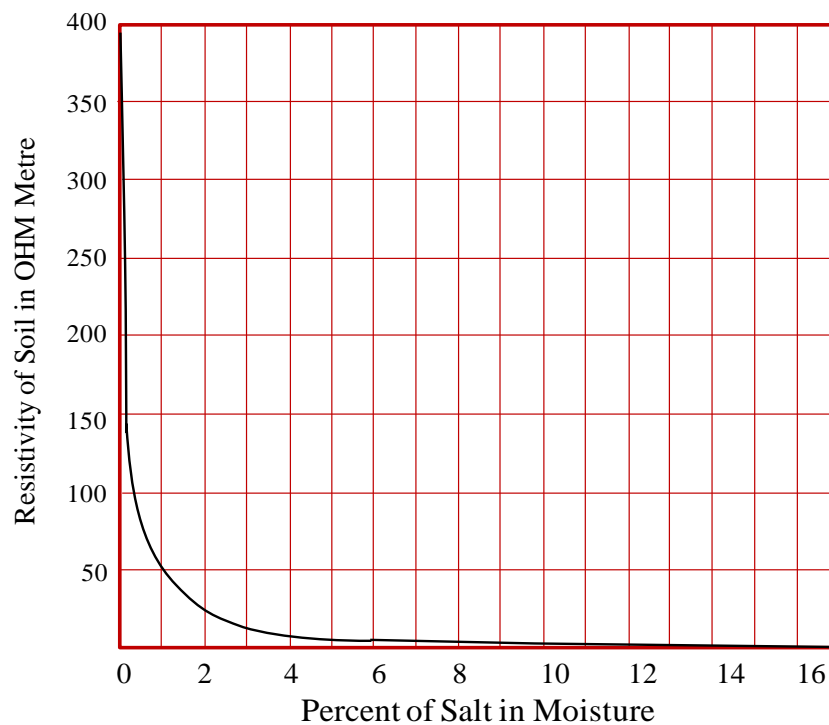


Figure 3: Variation of Soil Resistivity with Salt (NaCl) Content, Clay Soil Having 3 Percent Moisture

The salt content is expressed in percent by weight of the moisture content in the soil. As can be seen from the above, the curve flattens off at about **5 percent**. A further increase in salt content will give a very little decrease in soil resistivity. **So, there is no point again, in just filling up the pit with salt.**

For example, if we consider volume of soil is  $1\text{M}^3$  (1440kg.), the moisture content at 10 percent will be about 144 kg. (10 percent of 1440 kg). The salt content shall be 5% of this (i.e.) 5% of 144kg, that is, about **7.2kg**. So, water addition should be about 144 kg and salt addition shall be about 7.2 kg per cubic metre of dry soil. Any further additions will not give appreciable benefits.

Further discussion on artificial treatment of soil is given in para



☞ The possible corrosive effect of the salt should be considered which may also reduce the life of the earth electrodes and connections.



☞ Bentonite or similar earth enhancing material may be advantageous in rocky terrain. Bentonite packing will increase the contact efficiency with the general mass of ground.

**1.12 Myth 12: Only high voltage lines pose a fatal danger and low voltage i.e. 240V AC domestic supply is not fatal.**

**Fact: “Not true”.**



Voltage creates the current flow through the body depending upon the body resistance. Any voltage above 50 Volt AC can be fatal to human being. As per para 31.1.1.1 of IS 3043:2018 conventional touch voltage limit is 50V AC. Details of various effects of current on human body are explained further in this book.

**1.13 *Myth 13: All Rubber shoes/Sleepers/gloves can protect from electric shock.***

***Fact: Partially true***

Not all rubber shoes/sleepers/gloves provide full protection from electric shock. Proper voltage-rated rubber gloves and shoes that are certified as electrically safe for that rated voltage can only protect against electric shock.

**1.14 *Myth 14: Wood is an insulator and wooden ladders cannot conduct electricity.***

***Fact: Partially True***

Wood is a poor conductor but it can conduct electricity, especially when wet or when it has metal brackets. Using a wooden ladder when working with live electrical wiring is not a guarantee of safety. Additional guidelines, such as equipotential bonding of all metal parts including live wires and body of equipment, wearing voltage insulated gloves, shoes and working with de-energized circuits can only give protection against electric shock.

**1.15 *Myth 15: Neutral& body of every transformer/DG and the metallic parts not intended as conductors each requires two separate and distinct connections to earth electrodes in soil.***

**Myth Explanation**

There is a practice of connecting transformer (or DG) neutral terminal by two separate earth electrodes in soil. Body of transformer (or DG) is also connected by two separate earth electrodes in soil as per the interpretation of rule no 41 of CEAR (MEASURES RELATING TO SAFETY AND ELECTRIC SUPPLY)-2010 as figure given below.

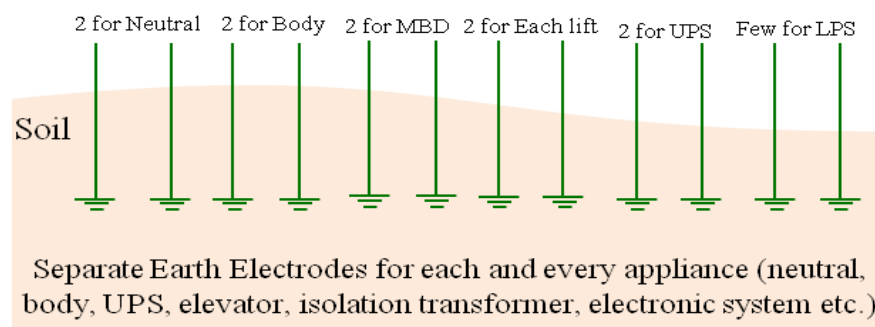


Figure 4: Wrong practice of connecting every appliance to two separate earth electrodes.

***Fact: Not True***

Due to this misinterpretation every electrical apparatus is connected to earth electrode in soil by 2 separate earth pits. This misinterpretation is probably the biggest threat for

electrical safety in India. Neither CEAR-2010 nor IS standards recommend these practices.

Before going further make sure you have read **myth-1**. The distinction between earth, earthing and earth electrode has already been elaborated at Myth-1.

Selective part of CEAR 2010, Regulation 41 are reproduced below to understand this myth:

*“The following conditions shall apply to the connection with earth of systems at voltage normally exceeding 125 V but not exceeding 650 V, namely:”*

- (i) *Neutral conductor of a 3-phase, 4-wire system and the middle conductor of a 2-phase, 3-wire system shall be earthed by not less than two separate and distinct connections with a minimum of two different **earth electrodes** or such large number as may be necessary to bring the earth resistance to a satisfactory value both at the generating station and at the sub-station.*

**Interpretation:-** It is the Neutral conductor (not neutral point) which is required to be connected by not less than two separate and distinct connections with a minimum of two different **earth electrodes**.

- (iii) *In the case of a system comprising electric supply lines having concentric cables, the external conductor of such cables, shall be **earthed** by two separate and distinct connections with **earth**.*

**Interpretation:-** It says the armour and/or sheath of such cables shall be **earthed** by two separate and distinct connections with **earth, not with the two** separate and distinct **earth electrodes**.

- (iv) *The frame of every generator, stationary motor, portable motor, and the metallic parts, not intended as conductors, of all transformers and any other apparatus used for regulating or controlling electricity, and all electricity consuming apparatus, of voltage exceeding 250 V but not exceeding 650 V shall be **earthed** by the owner by two separate and distinct **connections** with earth.*

**Interpretation:-** It says the metallic frame of every generator and the metallic parts, not intended as conductors, shall be **earthed** by two separate and distinct connections with **earth, not with the two** separate and distinct **earth electrodes**.

- (v) *Neutral point of every generator and transformer shall be earthed by connecting it to the earthing system by not less than two separate and distinct **connections**.*

**Interpretation:-** It is Neutral point not neutral conductor which is required to be connected by not less than two separate and distinct connections with earthing system, **not with the two** separate and distinct **earth electrodes**.

As per above, the Transformer (or DG) body need to be connected to earth and not to specifically separate earth electrodes in soil. The regulation never recommended to connect Transformer (or DG) Neutral and body to separate earth pits. This wrong practice followed is merely a misinterpretation of the regulation.

However, wrong practices create accidents during fault. Following figures explain the above discussion for better understanding.

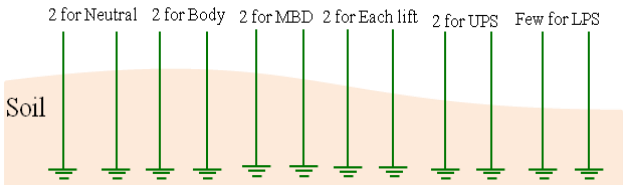
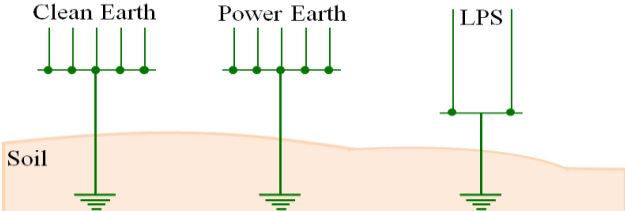
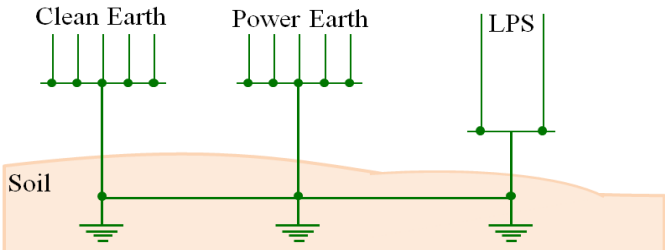
 <p>Soil</p> <p>Separate Earth Electrodes for each and every appliance (neutral, body, UPS, elevator, isolation transformer, electronic system etc.)</p>	<p><b>WRONG CONCEPT</b></p> <p>Typical Indian practice. This wrong practice may lead to accidents, deterioration of insulation, reduced life, malfunctioning of electronics.</p>
 <p>Soil</p> <p>Independent (separate) earth electrode in soil. Separate for instrumentation, Separate for electrical, Separate for LPS</p>	<p><b>WRONG CONCEPT</b></p> <p>Independent earth electrodes resulting accidents, deterioration of insulation, reduced life, malfunctioning of electronics.</p>
 <p>Soil</p> <p>All earth electrodes in soil interconnected as a grid under soil. Separate for electronics, Separate for electrical, Separate for LPS</p>	<p><b>WRONG CONCEPT</b></p> <p>Separate earth electrodes connected as a grid under soil, resulting accidents, deterioration of insulation, reduced life, malfunctioning of electronics, additional problems due to circulating currents.</p>

Figure 5: Wrong practices of separate earth electrodes in soil

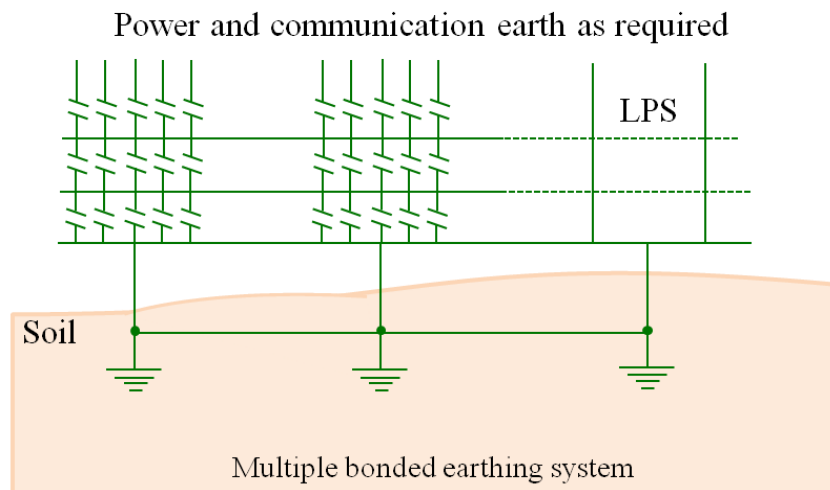


Figure 6: Right practice of Earthing

**GOOD PRACTICE**

- ✓ This is correct practice to connect all earthing conductors and earth electrodes to create an equipotential bonding among all for safe and maximum life of electrical and electronic system.

## 2.0 PURPOSE OF EARTHING

(Ref: IS 3043:2018, 11.1.3)

- Earthing of an electrical system or installation is provided for the reasons of safety. The earth connection improves service continuity, avoids damage to equipment and danger to human life.
- Earthing also reduces the risk of a person in the vicinity of earthed facilities being exposed to the danger of critical electric shock.
- Earthing in a substation is done to provide as nearly as possible a surface at a uniform potential and as nearly as zero or absolute earth potential. The purpose of this is to ensure that all parts (metal parts/exposed conductive parts) of apparatus/equipment other than live parts shall be at uniform/earth potential. This will also ensure that user/operator will always remain at earth potential at all times.
- Earthing also provides stable platform for operation of sensitive electronic equipment i.e., to maintain the voltage at any part of an electrical system at a known value so as to prevent over current or excessive voltage on the appliances or equipment.
- Earthing also provides a low earth fault loop impedance to facilitate automatic disconnection of supply in the event of a fault to exposed conductive parts of equipment/ apparatus.
- Earthing will also help to limit the rise in potential (touch voltage) of non-current carrying metal parts with respect to earth under earth-fault conditions to a value which is not harmful for the safety of persons/animals in contact/proximity to such metal parts.
- Earthing also provides safe path to dissipate lightning current to earth.

## 3.0 EARTHED AND UNEARTHED SYSTEMS

(Cl. No.5 of IS 3043-2018)

Table 1: Comparison between Earthed and Unearthed System

<b>Earthed systems</b>	<b>Unearthed system</b>
Earthed systems are designed and installed so that the protective devices provided in the circuit will operate and remove the faulty circuit from the system in case of any earth fault. In this way the faulty circuit can be isolated from rest of the system even in case of first earth fault before any damage.	In case of un-earthed system, on occurring first earth fault, neither circuit performance will be affected nor there will be any indication and in general there will also be no service interruption. The occurrence of a second earth fault on a different phase before the first fault is cleared, does result in an outage.
It is experienced that multiple earth faults are rarely, if ever, experienced on earthed neutral systems.	The longer a earth fault is allowed to remain on an unearthed system, greater is the probability of a second one occurring in another phase, causing failure and repairs are required to restore service.
In earthed system, any earth fault is detected and isolated by automatic disconnection of supply.	For unearthed system, an organized maintenance programme is extremely necessary so that earth fault if any is traced and removed soon after

Earthed systems	Unearthed system
	detection.
<p>In earthed system, the protection of personnel and property from hazards are ensured thorough earthing of equipment and structures.</p> <p>Proper earthing results in less chance of accidents/electrocution to personnel.</p>	<p>In unearthed system also, the protection of personnel and property from hazards are required thorough earthing of equipment and structures.</p> <p>An earth fault does not open the circuit in an unearthed system, some means of detecting the presence of an earth fault requires to be installed like Insulation monitoring, leakage current monitoring etc.</p>

#### 4.0 EQUIPMENT EARTHING

(Ref: IS 3043:2018, Para 12.0)

Earthing of non-current carrying metal work & conductor which is essential to the safety of human life, animals and property is known as **Equipment Earthing or Protective Earthing**. (Ref IS 3043:2018 Forward para 6)

“Equipment earthing or protective earthing of low voltage installation as per IS732:2019 is provided to limit the potential with respect to the general mass of earth of non-current carrying metal works associated with equipment, apparatus and appliance connected to the system”.( Ref IS 3043:2018 1.1 (a))

The basic objectives of equipment earthing are:

- a) “To ensure freedom from dangerous electric shock/voltages exposure to persons in the area”.
- b) “To provide adequate earth fault current carrying capability, both in magnitude and duration, permitted by the protective system without creating a fire or explosive hazard to building/equipment”.

#### 4.1 Earthing of Equipment using Current

(Ref: IS 3043-2018, para 11.1.4)

Class I appliances are usually made of metal, have three cables, it has a metal Earth pin (Earth wire of the equipment which comes to the earth pin of 3 pin plug top). Appliances under Class I have two levels of protection, the basic insulation and the earth connection. Accessible/exposed metal parts of Class-I equipment/appliances that may become live in the event of an insulation failure, shall be permanently and reliably connected to an earthing terminal within the appliance or to the earthing contact of the appliance inlet. Ex. Iron, refrigerators, microwaves etc.

**Class I Equipment (Ref IS 9049:1980)**

Equipment in which protection against electric shock does not rely on basic insulation only, but which, includes an additional safety, precaution in such a way that means are provided for the connection of accessible conductive parts to the protective (earthing) conductor in the fixed wiring of the installation in such a way that accessible conductive parts may not become live in, the event of a failure of the basic insulation.



⚡ Do not connect Earthing terminal and earthing contact of the equipment to the neutral terminal.

A Class II (double insulated) electrical appliance is one which has been designed in such a way that it does not require a safety connection to electrical earth. Class II equipment, may not have provision for connection of exposed metal work of the equipment to a protective/earth conductor. Ex Mobile chargers, Hand Dryers, TV etc.

#### **Class II Equipment (Ref IS 9049:1980)**

Equipment in which protection against electric shock does not rely on basic insulation only but in which additional safety precautions such as double insulation or reinforced insulation are provided, there being no provision for protective earthing or reliance upon installation conditions.

## **4.2 Voltage Exposure**

(Ref: IS 3043-2018, para 12.0.2)

When there is unintentional contact between an energized electric conductor (live conductor) and the metal frame (body) or enclosure/ structure, the frame or structure tends to become energized to the same voltage level as exists on the energized conductor.

In such cases, to avoid the dangerous voltage on exposed metal frame (body) the equipment earthing conductor provides a low impedance path from the metal frame to the zero potential earth junction (MET).

Impedance/Resistance of Protective conductor from point of installation (Equipment) to MET should be sufficiently low enough to avoid creation of dangerous voltage on equipment.

### **4.2.1 Avoidance of Thermal Distress**

The earthing conductor also functions to carry the full earth fault current without excessively raising the temperature of the earthing conductor or causing the expulsion of arcs and sparks that could initiate a fire or explosion.

### **4.2.2 Preservation of System Performance**

The earthing conductor must return the earth fault current back to the source without introducing additional resistance/impedance to such an extent that would affect the operation of OCPD.

### **4.2.3 Earthing & Protective Conductor**

**Earthing Conductor:** - A protective conductor connecting the main earthing terminal (or the equipotential bonding conductor of an installation when there is no earth bus) to an earth electrode or to other means of earthing. (Ref: IS 3043-2018, para 3.13)

In general earthing conductor is the conductor connecting the MET to electrode. The earth conductor designated as 'E' shall not be coloured i.e. it shall have the original **colour of bare conductor.** (Ref: IS 3043-2018, para 11.2)



☞ No switching device shall be inserted in the protective conductor, but joints which can be disconnected for test purposes by use of a tool may be provided.

### **Protective conductor**

(Ref: IS 3043-2018, para 3.26)

*Protective Conductor* — A conductor used as a measure of protection against electric shock and intended for connecting any of the following parts:

- a) Exposed conductive parts,
- b) Extraneous conductive parts,
- c) Main earthing terminal, and
- d) Earthed point of the source or an artificial neutral.

The protective conductor designated as 'PE' shall have bi-colour combination, **green and yellow** (green/ yellow), for identification as protective conductor and for no other purpose. (Ref: IS 3043-2018, para 11.2)



Figure 7: Marking of Earth Conductors

Bare conductors or bus bars, used as protective conductors, shall be coloured by equally **broad green and yellow stripes**, each 15 mm up to 100 mm wide, close together, either throughout the length of each conductor or in each compartment or unit or at each accessible position. If adhesive tape is used, only bicoloured tape shall be applied.

For insulated conductors, the combination of the colours, green and yellow, shall be such that, on any 15 mm length of insulated conductor, one of these colours covers 30-70% of the surface of the conductor & other colour cover the remaining surface.

## **5.0 SYSTEMEARTHING**

(Ref: IS 3043:2018, para 11.0)

*Earthing associated with current-carrying conductor which is normally essential to the security of the system is known as **System Earthing**.* (Ref IS 3043:2018,foreword para 6)

System earthing of low voltage installation is carried out to limit the potential of current carrying conductor forming part of the electrical system with respect to general mass of earth. Earthing of system is designed primarily to preserve the security of the system by ensuring that the potential on each conductor is restricted to such a value as is consistent with the level of insulation applied.

The basic objective of system earthing is to ensure efficient and fast operation of protective device in the case of earth faults. The system earth fault loop impedance should be such that, when any earth fault occurs, the protective device (circuit-breakers or fuses etc.) will operate to isolate the faulty main or equipment.

In system earthing only one point (i.e. Neutral in TN & TT systems) is earthed to prevent the passage of current through the earth under normal conditions and thus to avoid the accompanying risks of electrolysis and interference with communication circuits. (In case more than one point is earthed it will lead to creation of local loops in the system there by flowing of circulating current which may cause electromagnetic induction).

## 6.0 TYPES OF SYSTEM EARTHING

Any system comprises mainly two portions, first the source of energy (transformer/ DG) and second is installation. The source includes supply cables/ conductor connecting to the installation. The supply system is generally denoted by two letters as shown below:

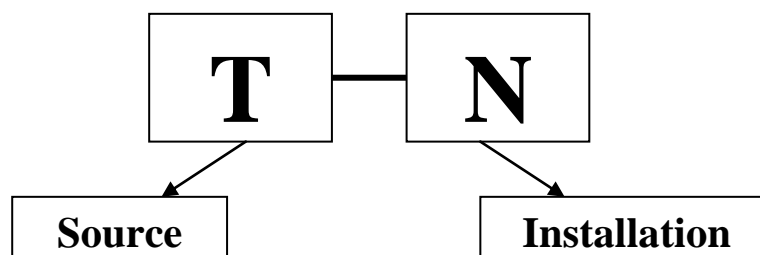


Figure 8: Indicative supply system based on system earthing

### Description of letters:

<b>The first letter refers to the relationship of the power system (source) to earth.</b>	
T	'Direct connection of one point to earth'.
I	'All the live parts isolated from earth, or one point connected to earth though a high impedance'.
<b>Second letter refers to the relationship of the exposed-conductive-parts of the installation to earth'.</b>	
T	'Direct electrical connection of exposed conductive parts to earth, independently of the earthing any point of the power system'.
N	'Direct electrical connection of exposed conductive parts to the earthed point of the power system'. (in ac systems, the earthed point of the power system is normally the neutral point or, if a neutral point is not available, a line conductor).
<b>Subsequent letters if any,</b>	
S	Separate neutral and protective earth functions provided by separate conductors i.e. PE & N conductor.
C	Combined neutral and protective earth functions provided by same conductor i.e. PEN/CNE conductor.

### The letters used in European Standards are derived from the French language:

- T - Terre which represents Earth
- N – Neutre which represents Neutral
- S – Separe which represents Separate
- C – Combine which represents Combined
- I – Isole which represents Insulated

Electrical supply systems are further classified as TN system, TT system and IT system based on system earthing. They are as given under.



### 6.1 TN System

TN system has one or more points of the source of energy(preferably Neutral point of Transformer or DG)directly earthed at source end. The exposed and extraneous conductive parts of **the consumer installation are connected by means of protective conductors to the earthed point(s) of the source.** In this way, there is a metallic return path for earth fault currents to flow from the installation to the earthed point(s) of the source. TN systems are further sub-divided into TN-S,TN-C and TN-C-S systems.



Every supply neutral conductor of electrical network of voltage 650 V and below is required to be connected with earth generally at the source of voltage. (Ref- IS 3043-2018 para 4.1 Note 2)

#### 6.1.1 TN-S System

In the system where **separate conductors each for neutral and protective functions are provided throughout the system** is called as **TN-S system** (as shown blow in figure).

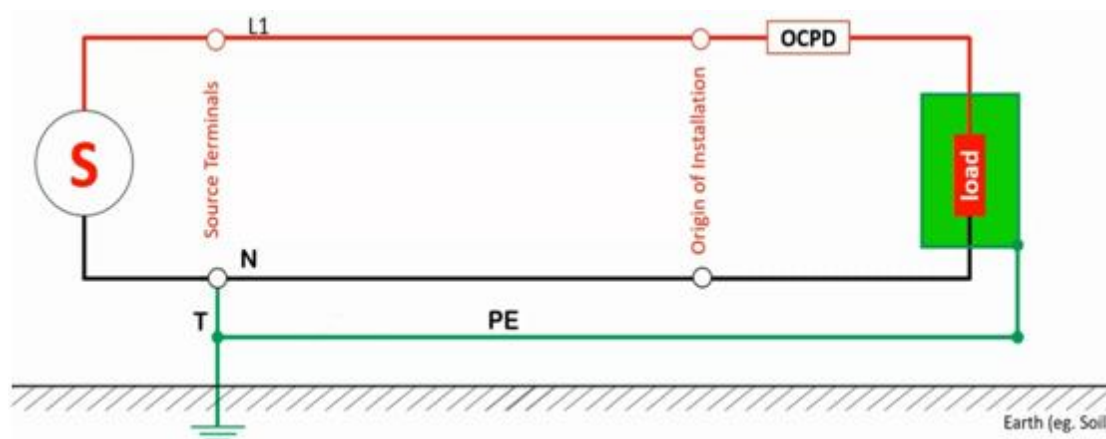


Figure 9: TN-S System

##### 6.1.1.1 For 230 V single phase domestic/commercial supply

(Ref: Fig. 12 of IS 3043-2018).

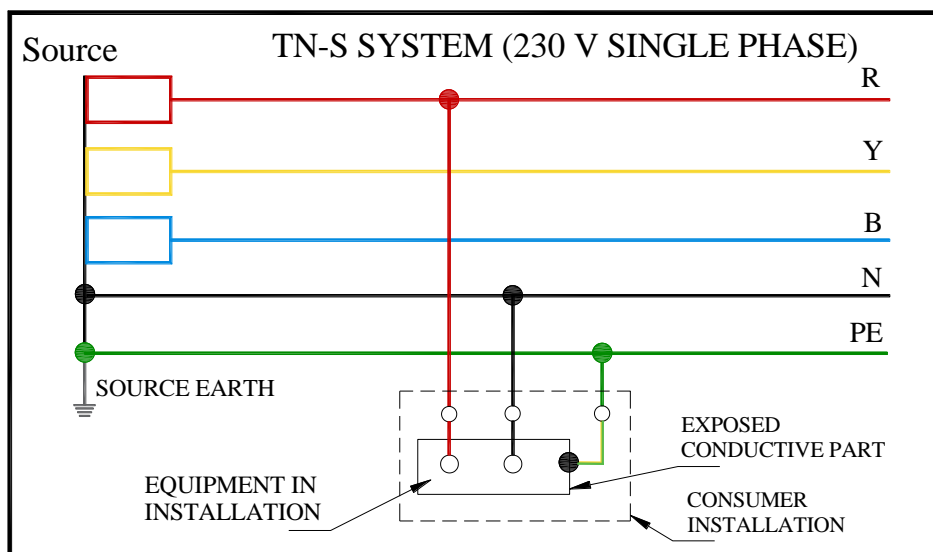


Figure 10: TN-S System for 230V Single Phase

- The protective conductor (PE) is the metallic covering (armour or sheath of the cable supplying the installation) or a separate conductor.
- All exposed conductive parts of an installation are connected to this protective conductor **via main earthing terminal** of the installation.

### 6.1.1.2 For 415 V three-phase domestic/commercial supply

- 415 V three phase domestic/ commercial supply having three phase and single phase loads, all exposed conductive parts of the installation are connected to protective conductor via the **main earthing terminal** of the installation.
- It is necessary to install an independent **earth electrode** within the consumer's premises and same to be connected as shown in the figure given below (Ref: Fig. 13 of IS 3043-2018).

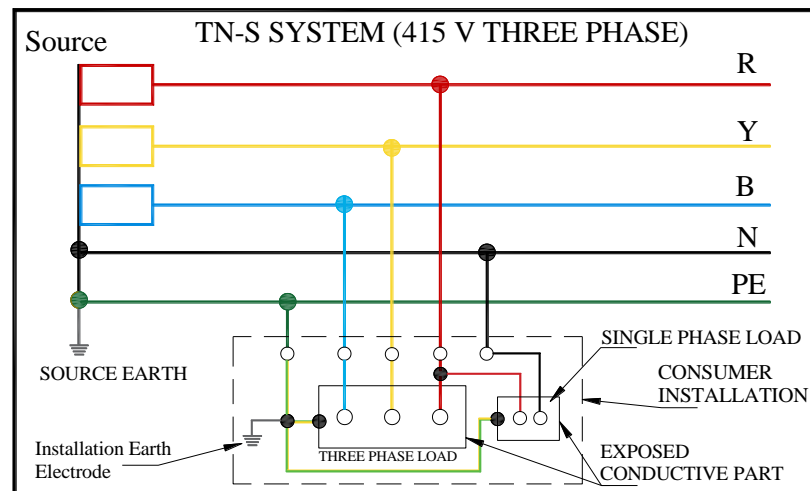


Figure 11: TN-S System for 415 V three-phase domestic commercial supply



⚡ TN-S system requires 5 conductors (three lines, one neutral and one protective conductor), due to this, cost of installation is high as compared to other systems.

### 6.1.2 TN-C System

In TN-C system, neutral and protective functions are combined in a single conductor throughout the system (Ref: Fig. 14 of IS 3043-2018).

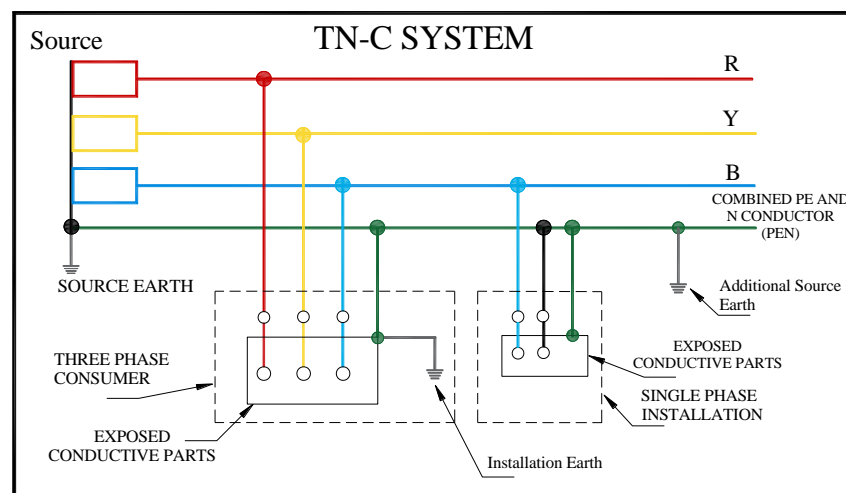


Figure 12: TN-C System

- All exposed conductive parts are connected to the PEN conductor.
- For three phase consumer, local earth electrode has to be provided in addition.

**TN-C systems are not suitable for modern installations with electronic equipment.**

**As the protective function and neutral function are combined in one conductor, in case of PEN conductor breaks/ disconnects due to any reason (neutral breakage), the exposed conductive parts in an installation becomes live, which may lead to shock hazards.**



Figure 13: Neutral breakage in TN-C System

### 6.1.3 TN-C-S System

In TN-C-S system, neutral and protective functions are combined in a single conductor (PEN conductor) only in part of the system. Usually, the neutral and protective functions are combined in a single conductor up-to consumer's premises and separate at installation side as shown in the figure below.

All exposed conductive parts of an installation are connected through protective conductors. All the protective conductors/connections run separately inside consumer's premises and connected to main earthing terminal (MET) and then to the PEN conductor. (Ref: Fig. 15 of IS 3043-2018).

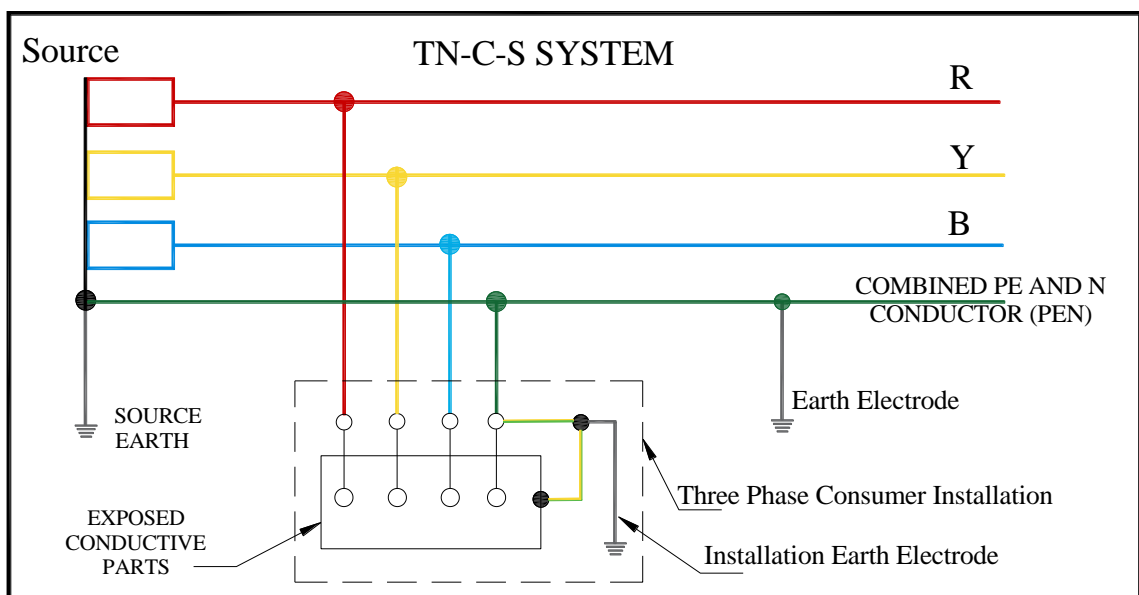


Figure 14: TN-C-S System

**This system requires only four conductors in public distribution (i.e. up-to incoming supply at consumer's premises). This saves the cost of 5<sup>th</sup> conductor in public distribution.**

- The supply system PEN conductor is earthed at several points. Therefore, this type of distribution is known also as Protective Multiple Earthing(PME) and the **PEN conductor is also referred to as the Combined Neutral and Earth (CNE) conductor.**
- An earth electrode may be necessary at or near a consumer's installation.
- Multiple earthing of the PEN/CNE conductor ensures that if the conductor becomes open circuit for any reason (probably cut or snapped), exposed-conductor parts remain connected to earth, under such conditions the supply voltage between the installation line and neutral conductor is substantially reduced and consumer will experience unacceptable voltage variations.

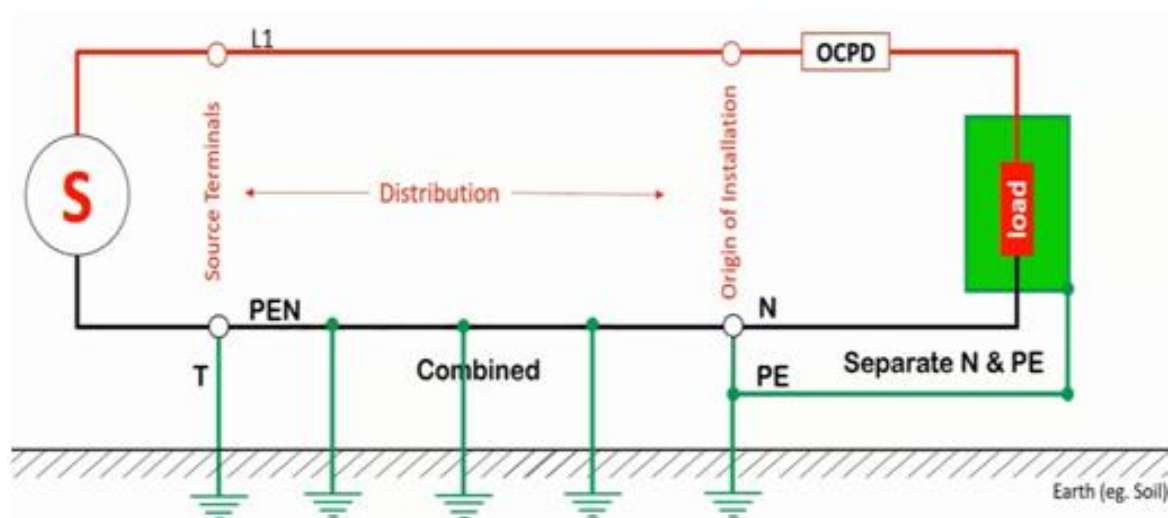


Figure 15: Multiple Earthing of PEN Conductor in TN-C-S System

- If PME is not provided to PEN conductor any breakage of it may cause dangerous rise in potential of exposed-conductor parts and which may lead to shock hazards.



As per statutory provisions for earthing mentioned in Cl. No. 4 of IS 3043-2018. The TN-C-S is the most common system adopted by Electrical supply undertakings. TN-C-S system is also called as Protective Multiple Earthed (PME) system

## 6.2 TT System

**TT system** has one or more points of the source of energy directly earthed and the exposed and extraneous conductive parts of the installation are connected to a local earth electrode. Source and installation earth electrodes are electrically independent. (Ref: Fig. 17 of IS 3043-2018).

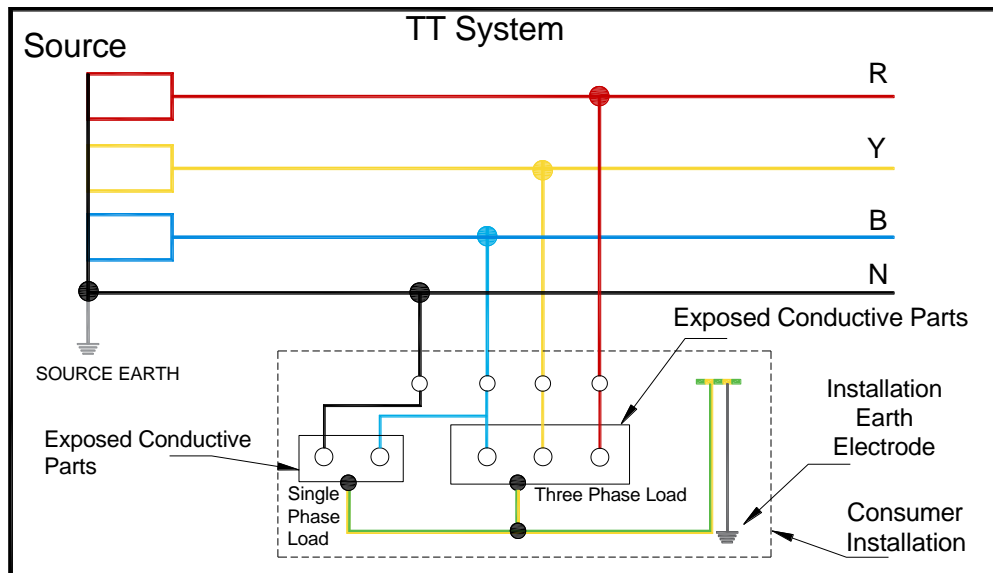


Figure 16: TT System

- All exposed conductive parts of an installation are connected to an independent earth electrode.
- Single phase TT system is not present in India.

### 6.3 IT System

**IT system** has the source either unearthed or earthed through a **high impedance** and the exposed conductive parts of the installation are connected to electrically independent earth electrodes. (Ref: Fig. 18 of IS 3043-2018).

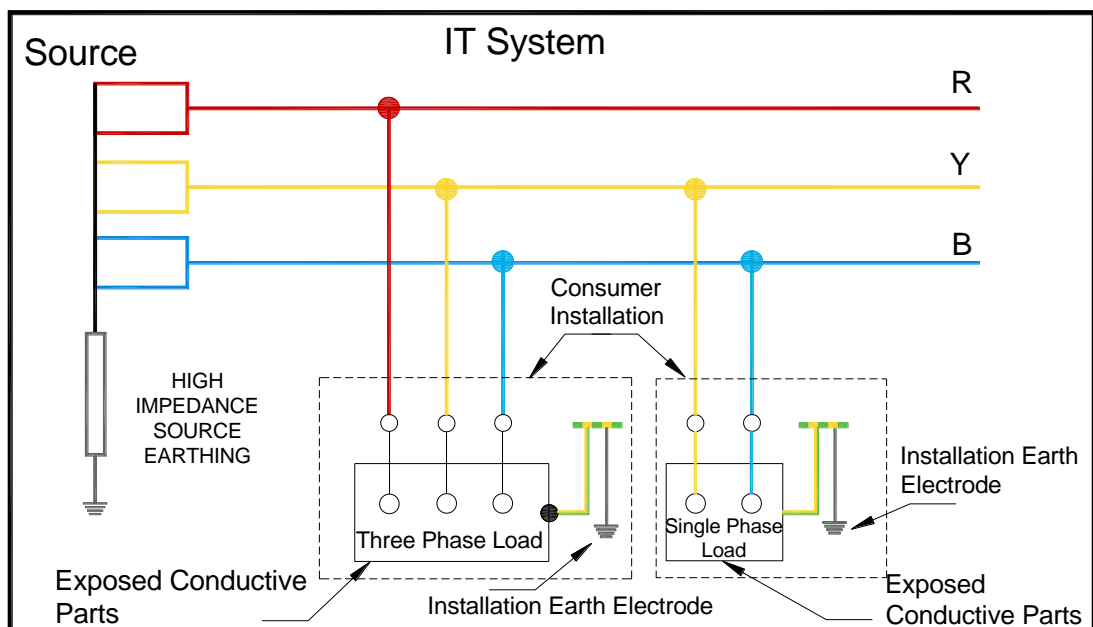


Figure 17: IT System

- All exposed conductive parts of an installation are connected to an earth electrode.
- The source is either connected to earth through deliberately introduced earthing impedance or is isolated from earth.
- IT system is used where continuity of supply is desired.

## 7.0 EQUIPOTENTIAL BONDING

“Electrical connection putting various exposed conductive parts and **extraneous conductive parts** at a substantially equal potential is termed as equipotential bonding”. (ref: IS:3043-2018 para no. 3.15)

Equipotential is derived from Equal potential between two points. In a system, connections of all non-current carrying (exposed conductive parts) parts of a current using equipment like metal body of equipment, etc. & connections of all non-electrical metallic items embedded in building structure(extraneous conductive parts) for ex Reinforced steel in concrete, Metallic pipe lines, etc. to main earthing terminal in order to bring all at same potential (Equipotential) in event of an earth fault is called Equipotential bonding.

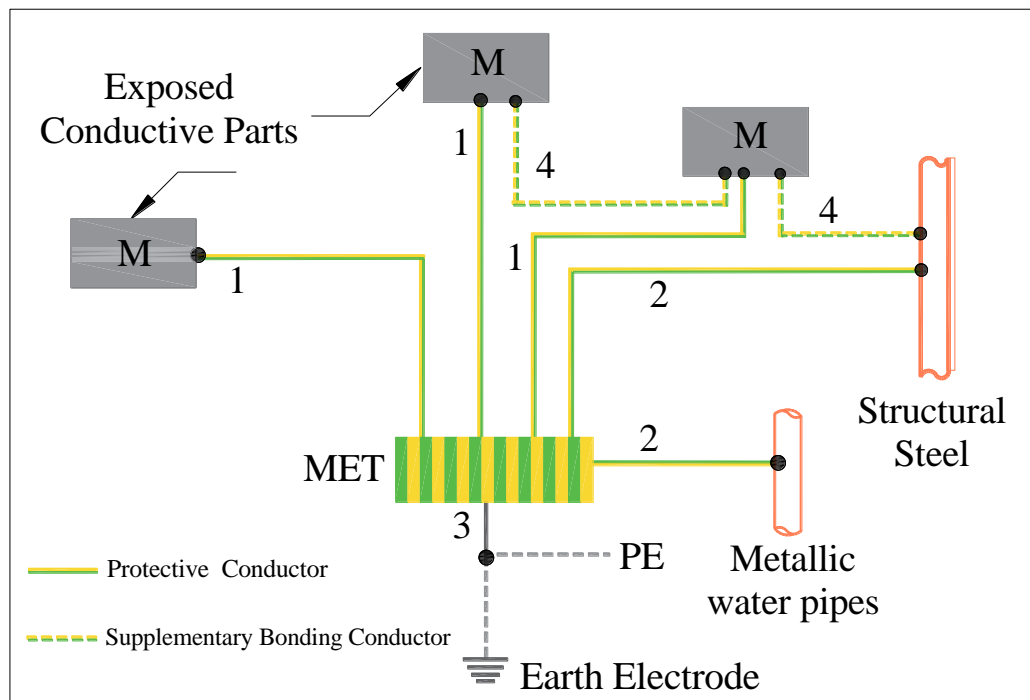


Figure 18: Equipotential bonding with all exposed/extraneous conductive parts

	Structural steel (extraneous-conductive-part)
	Metallic water pipe (extraneous-conductive-part)
	Earth electrode (TT and IT system)
	PE (TN systems)
1	Circuit protective conductor
2	Main protective bonding conductor
3	Earthing conductor
4	Supplementary protective bonding conductor (if required)
1,2,3,4	Protective conductors

Common equipotential bonding system has both protective equipotential bonding and functional equipotential bonding.

## 7.1 Protective Equipotential Bonding

(Ref: IS 732:2019 para 3.150, 4.2.11.3.1.2)

Equipotential bonding done for the purpose of safety is termed as “Protective Equipotential bonding”. In this protection is achieved by automatic disconnection of supply.

In each building the earthing conductor, the main earthing terminal and the following conductive parts shall be connected to the protective equipotential bonding:

- i. Metallic pipes supplying services into the building, for example, gas, water, fire fighting, sewage etc.
- ii. Structural extraneous conductive parts, if accessible in normal use, metallic central heating and air-conditioning systems; and
- iii. Metallic reinforcements of constructional reinforced concrete, if reasonably practicable.

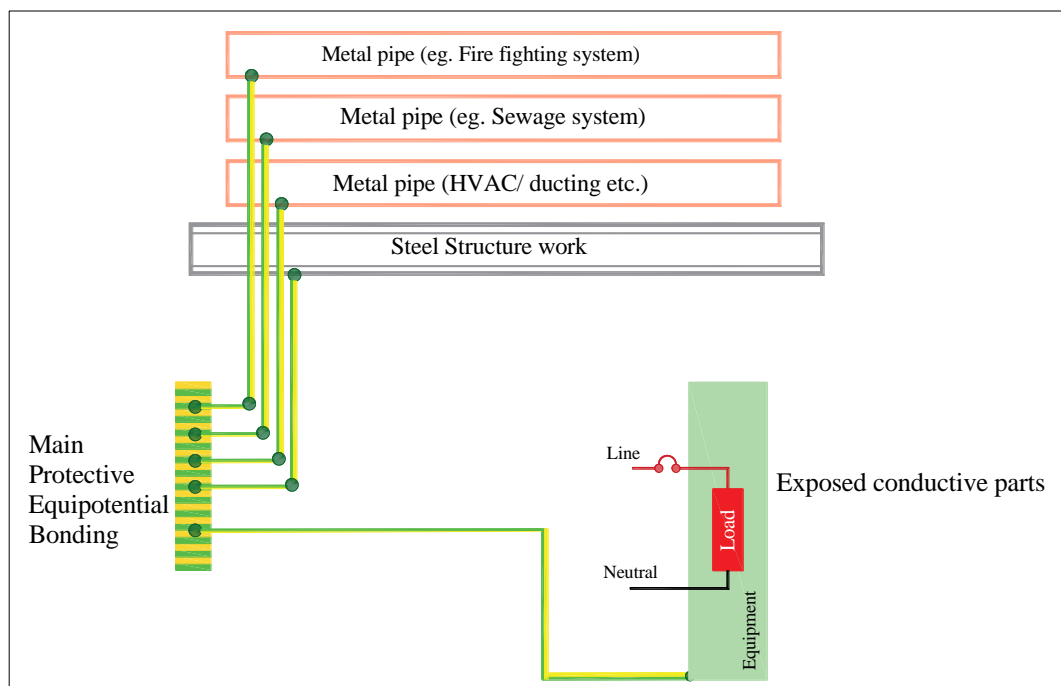


Figure 19: Equipotential Bonding with all exposed/extraneous conductive parts

Note :- Where such conductive parts originate outside the building, they shall be bonded as close as practicable to their point of entry within the building.

## 7.2 Supplementary Equipotential Bonding

Supplementary Equipotential Bonding is also called as local equipotential bonding. This is done to achieve high degree of safety against electric shock, Supplementary equipotential bonding is considered as an addition to fault protection. This will also reduce the voltages occurring in the event of an earth fault still further.

During design of an electrical system if the fault loop impedance which is required for automatic disconnection of supply is not achieved through equipotential bonding, then it is necessary to provide supplementary equipotential bonding.(Ref: IS 3043: 2018 para 11.1.3)

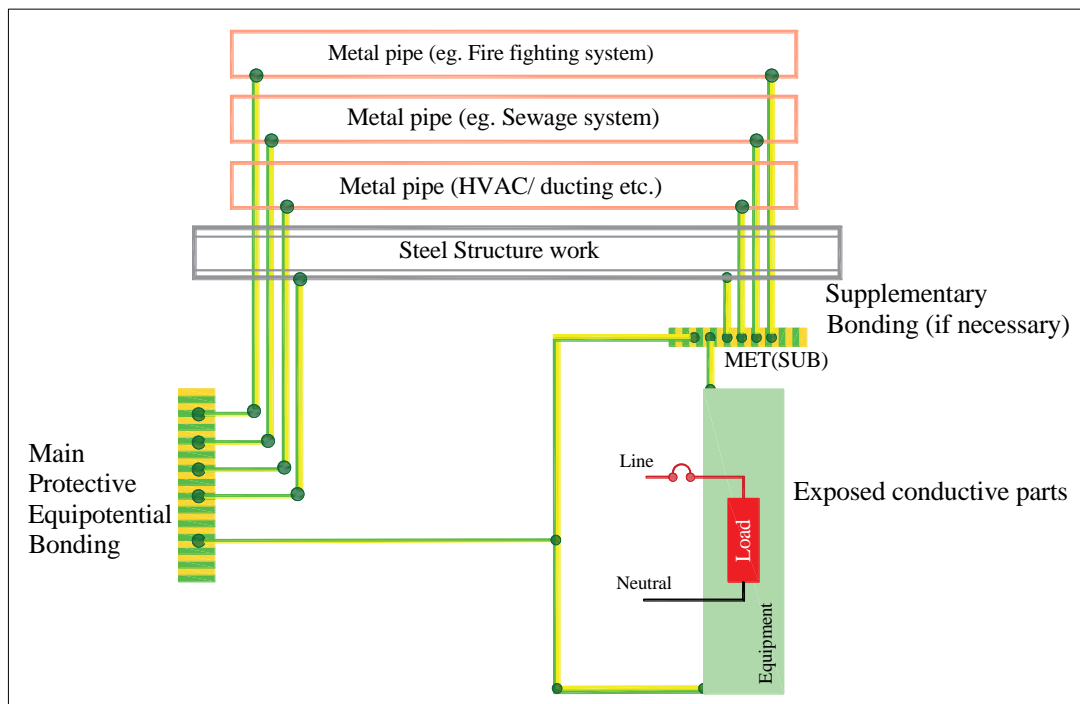


Figure 20: Equipotential Bonding with Supplementary Bonding

### 7.3 Main Earthing Terminal (MET)

*“The terminal or bar (which is the equipotential bonding conductor) provided for the connection of protective conductors and the conductors of functional earthing, if any, to the means of earthing. (Ref: IS 3043:2018, para no. 3.21)*

- The **function of MET is to provide a reference point for the installation**, it consists of a terminal or bar provided for the connection of protective conductors and conductors for functional earthing.
- MET is connected to earth but it remains rarely at zero potential because of the potential difference caused by leakage and other current flowing to earth.



Figure 21: Main Earthing Terminal (MET)





☞ In the case of TT and IT system, the MET should be earthed by an independent earth electrode only.



☞ All connections shall be carefully made on MET if they are poorly made or inadequate for the purpose for which they are intended, loss of life or serious personal injury may result.

#### 7.4 Typical Schematic of Earthing and Protective Conductors

A typical schematic of earthing and protective conductors is shown in given below figure. In the installation, all protective conductors of exposed conductive parts are connected to main earthing terminal at distribution boards. Further the METs of all distribution boards are connected to main MET. All extraneous conductive parts, incoming metallic service pipes, are also connected to main MET. Further this main MET is connected to earth electrodes by Earth conductor or PEN conductor as per design of the supply system.

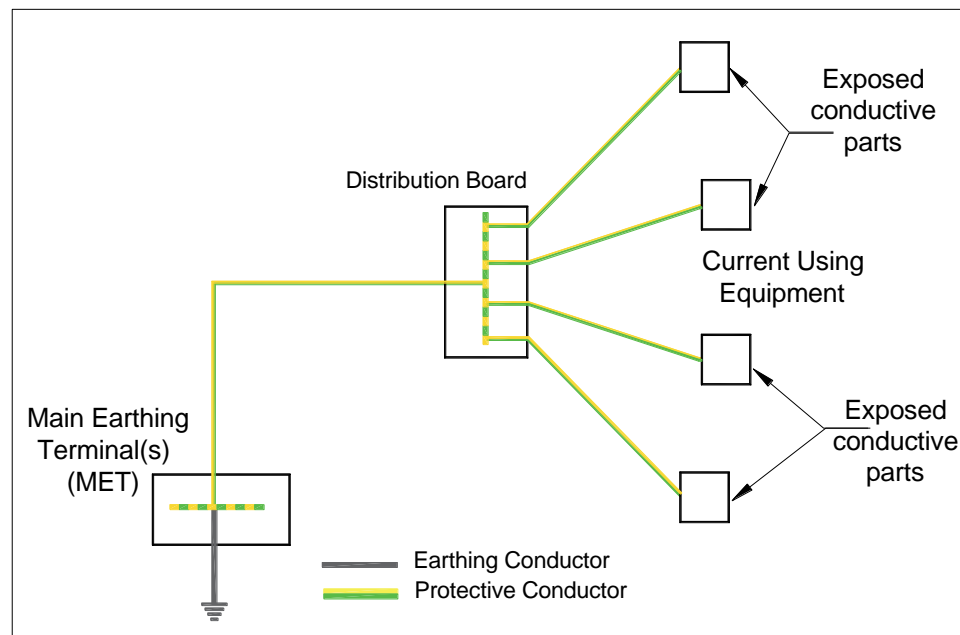


Figure 22: Earthing Arrangements and Protective Conductors



☞ No switching device shall be inserted in the protective conductor, but joints which can be disconnected for test purposes by use of a tool may be provided.



☞ During designing of a system, earthing conductors are also protective conductors and should be sized in the same way as other protective conductors.

## 7.5 Extraneous Conductive Parts (Ref IS 3043:2018 para 23.2.3 )

The extraneous conductive parts that are required to be bonded to the main earthing terminal of the installation (or to the earth electrode of the installation) include:

- a) Gas pipes,
- b) Other service pipes and ducting,
- c) Risers and pipes of fire protection equipment,
- d) Exposed metallic parts of the building structure, and
- e) Lightning conductors.

## 7.6 Exposed Conductive Parts (Ref IS 3043:2018 para 23.2.4)

Exposed conductive parts that are required to be connected by means of protective conductors to the **main earthing terminal** of the installation are as follows:

- a) All metal structure associated with wiring system (other than current-carrying parts) including cable metal sheaths and armour, conduit, ducting, trunking, boxes and catenary wires.
- b) The exposed metal structure of all Class I equipment fixed and portable current-using equipment. All fixed wiring accessories should incorporate an earthing terminal that is connected to the main earthing terminal by means of the protective conductors of the circuits concerned.
- c) The exposed metal structure of transformers used in the installation other than those that are an integral part of equipment.

### 7.6.1 Exposed conductive parts not required to be earthed

Exposed conductive parts that (because of their small dimensions or disposition) cannot be gripped or contacted by a major surface of the human body (that is, a human body surface not exceeding 50 mm x 50 mm) need not be earthed if the connection of those parts to a protective conductor cannot readily be made and reliably maintained.

Typical examples of such parts are:-

- a) Screws and nameplate, cable clips and lamp caps.
- b) Fixing screws for non-metallic accessories need not be earthed provided there is no appreciable risk of the screws coming into contact with live parts.

Other exposed conductive parts not required to be earthed

- c) Overhead line insulator brackets and metal parts connected to them if such parts are not within arm's reach.
- d) Short lengths of metal conduit or other metal enclosures used give mechanical protection to equipment of Class II or equivalent construction.

## 8.0 EARTH FAULT PROTECTION IN LV INSTALLATIONS

### Direct Contact

Contact of persons or livestock with live parts of electric supply/ installation/ equipment which may result in electric shock is termed as direct contact.

#### Protection against direct contact (Basic protection)

(Ref: IS 732-2019 para 4.1.2.1)

Protection against direct contact is also termed as basic protection in low voltage installations, systems and equipment. This type of protection is provided against dangers that may arise from direct contact and can be achieved by one of the following methods:

- Preventing a current from passing through the body of any person or any livestock; and
- Limiting the current which can pass through a body to a non-hazardous value.

#### Measures for Protection against direct contact:

(Ref- IS732:2019 Annex A&B)

- By provision of insulation on live parts:** Live parts shall be completely covered with insulation which can only be removed by destruction.
- By provision of Barriers or enclosures:** Live parts shall be inside enclosures or behind barriers.



The occurrence of an earth fault in an installation creates two possible hazards. Firstly, voltages appear between exposed conductive parts and extraneous conductive parts, and if these parts are simultaneously accessible, these voltages (potential difference) constitute a shock hazard, this condition being known as **Indirect contact**.

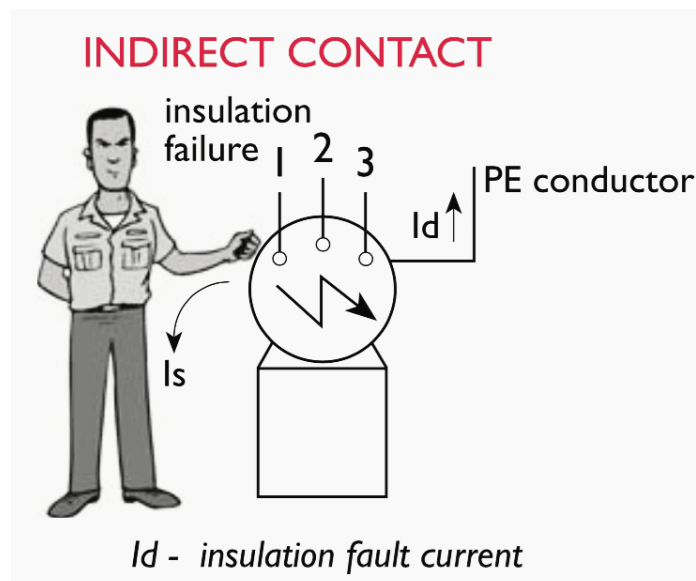


Figure 23: Indirect Contact in case of earth fault

Secondly, the fault current that flows in the phase and protective conductors of the circuit feeding the faulty equipment may be of such a magnitude as to cause an excessive temperature rise in those conductors, thereby creating a fire hazard.

## 8.1 Protection against Indirect Contact

Protection against indirect contact is achieved by the adoption of one of the following protective measures:

### 1) Safety extra low voltage (IS 9409:1980 para no 2.6)

A voltage which does not exceed 50 V ac rms between conductors or between any conductor and earth in a circuit which is isolated from the supply mains by means of a safety isolating transformer or converter with separate windings.

### 2) The use of Class II equipment or by equivalent insulation (*The detail of classes of equipment are explained in annexure*)

### 3) A non-conducting location (IS 732:2019 Para C-1)

The non-conducting location is a special arrangement where there is no earthing or protective system provided because there is nothing which needs to be earthed. In this non-conducting location all exposed conductive parts are so arranged that it is impossible to touch two of them, or an exposed conducting part and an extraneous conductive part, at the same time. This measure can only be applied in a dry location.

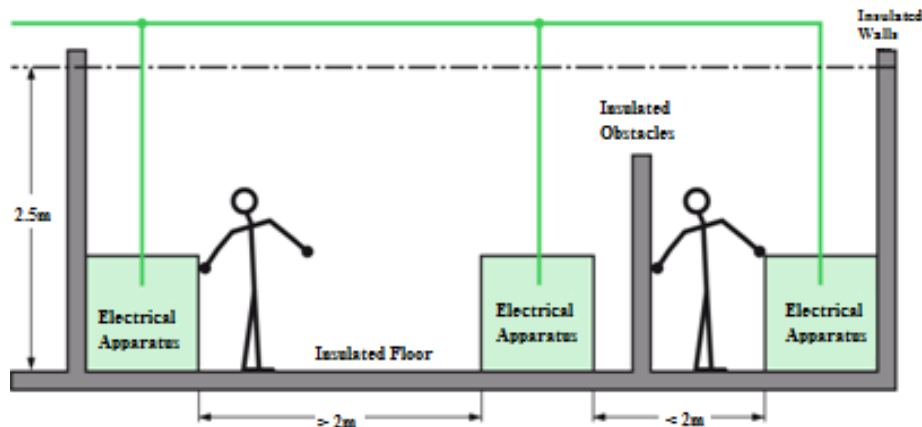


Figure 24: A Non Conductive Location

### 4) Earth free local equipotential bonding (IS 732:2019 Para C-2)

Earth-free local equipotential bonding is provided to prevent the appearance of a dangerous touch voltage by connecting equipotential bonding conductors with all simultaneously accessible exposed conductive parts and extraneous conductive parts without electrical connection to the earth directly and indirectly (i.e through exposed conductive- parts and extraneous-conductive-parts)

### 5) Electrical separation

Electrical separation is a protective measure in which, basic protection is provided by basic insulation of live parts or by barriers/enclosures and fault protection is provided by simple separation of the separated circuit from other circuits and from earth.

### 6) Earthed equipotential bonding and automatic disconnection of the supply

In order to achieve a high degree of protection against both shock and fire hazards the earthed equipotential bonding and automatic disconnection of the supply is used. Further it is explained in detailed below.

## 8.2 Earthed Equipotential Bonding and Automatic Disconnection of the Supply

The two aims of this protective measure are to:

- a) Ensure that when an earth fault occurs, the voltages appearing between exposed conductive parts and extraneous conductive parts in the location served by the installation concerned are minimized; and
- b) Ensure rapid disconnection of the circuit in which that earth fault occurs.

In order to meet (a), a zone is created by connecting all extraneous & exposed conductive parts by means of **equipotential bonding conductors** to the MET and earth electrode of the installation is called equipotential zone as explained earlier in para 7.0 in this booklet.

This does not mean that voltages cannot exist between conductive parts in that zone when an earth fault occurs a voltage will appear between the exposed conductive parts and extraneous conductive parts in the location served by the installation concerned, but the application of protective equipotential bonding minimizes these touch voltage reaches a harmful value.

An installation may consist of a number of zones; for instance, when an installation supplies a number of buildings, equipotential bonding is necessary in each building so that each constitutes a zone having a reference point to which the exposed conductive parts of the circuits and current-using equipment in that building are connected. (Ref: IS 3043:2018 para 23.2.2.1)

The second aim of this protective measure is to disconnect the supply to the faulty equipment within the prescribed time by limiting the upper value of the earth **fault loop impedance** of each circuit. On the occurrence of an earth fault (assumed to be of negligible impedance), disconnection will occur before the prospective touch voltage reaches a harmful value.

The choice of protective device used to give disconnection is influenced by the type of system of which the installation is part, because either:

- 1) The **earth fault loop impedance** has to be low enough to allow adequate earth fault current flow in order to cause operation of an over current protective device (for example, a fuse or MCB, MCCB) in a sufficiently short time.
- 2) Where it is not possible to achieve a low enough earth fault loop impedance, disconnection may be initiated by fitting a Residual Current Device (RCD) of 30 mA rating. (Ref- IS 732:2019 para 4.2.11.1).

Protection against shock in case of a fault (protection against indirect contact) is provided by automatic disconnection of supply and this is to prevent a touch voltage persisting for such long time that may be dangerous.

Automatic disconnection of supply following an insulation fault relies on the association of two conditions given below:

- a) The existence of a conducting path (fault loop) to provide for circulation of fault current (this depends on type of system earthing); and
- b) The disconnection of this current by an appropriate device in a given time.

The determination of this time depends on various parameters, such as probability of fault, probability of a person touching the equipment during the fault and the touch voltage to which a person might thereby be subjected.

### 8.2.1 Disconnecting Times for Different Touch Voltages

Limits of touch voltage are based on studies on the effects of current on human body (Ref IS/IEC 60479:2005). Table 2 shows the values disconnection time limits (t) for different touch voltages for two most common conditions (dry and wet conditions) for safety of human beings. If the system has to protect the human, it should trip with in the stipulated time limits. During the designing of system, the selection of protective devices can be done based on the tripping time w.r.t the prospective fault current. This fault current can be calculated with the help of System voltage and Fault loop impedance.

Table 2: Disconnecting Times for Different Touch Voltages  
(Ref- IS 3043:2018, Table 13)

Prospective Touch Voltage $U_c$	Condition 1 Dry or moist locations, dry skin and significant floor resistance			Condition 2 Wet locations, wet skin and low floor resistance		
	$Z_1$	I	t	$Z_2$	I	t
(V)	( $\Omega$ )	(mA)	(s)	( $\Omega$ )	(mA)	(s)
(1)	(2)	(3)	(4)	(5)	(6)	(7)
25	--	--	--	075	23	5
50	1725	29	5	925	54	0.47
75	1625	46	0.60	825	91	0.30
90	1600	56	0.45	780	115	0.25
110	1535	72	0.36	730	151	0.18
150	1475	102	0.27	660	227	0.10
220	1375	160	0.17	575	383	0.035
280	1370	204	0.12	570	491	0.020
350	1365	256	0.08	565	620	--
500	1360	368	0.04	560	893	--

Z1- Total Impedance of human body in Dry condition (IS 60479:2005 part 1)  
Z2- Total Impedance of human body in wet condition (IS 60479:2005 part 1)  
I – Current that will flow through the human body  
t- Disconnecting time limit which will not result in harmful physiological effects on Human body.

### 8.3 Requirement for Automatic disconnection in TN System

(Ref IS 3043:2018 para 23.0.7)

In TN system the characteristics of the protective devices and the cross-sectional area of conductors shall be so chosen that if a fault of negligible impedance occurs anywhere between a phase conductor and a protective conductor or exposed conductive part, automatic disconnection of the supply will occur within the minimum possible safe time. The time of operation would depend on the magnitude of the contact potential.

This requirement is met if:

$$Z_s \times I_a \leq U_o \dots \dots \dots (1)$$

where

$Z_s$  = fault loop impedance,

$I_a$  = current ensuring the automatic operation of disconnecting device, and

$U_o$  = conventional voltage limits.

➤  $Z_s$  may be calculated or measured.

- The duration of  $I_a$  permitted depends on the prospective touch voltage (please refer table 2 for prospective touch voltage and corresponding timings). Higher touch voltages should be cleared in shorter times.
- If this condition cannot be fulfilled, **supplementary bonding** may be necessary.

#### 8.4 Requirement for Automatic disconnection in TT System

(Ref IS 3043:2018 para 23.0.8)

In TT system the characteristics of the protective devices and the cross-sectional area of conductors shall be so chosen that if a fault of negligible resistance occurs any where between a phase conductor and a protective conductor or exposed conductive parts, automatic disconnection of the supply will occur within the minimum possible safe time. The time of operation would depend on the magnitude of the contact potential.

This requirement is met if:

$$R_A \times I_a \leq U_c \dots \dots \dots (2)$$

where

- $R_A$  = resistance of the earthed system for exposed conductive parts,
- $I_a$  = operating currents of the disconnecting series device or settings of shunt relays, and
- $U_c$  = conventional voltage limit

#### 8.5 Requirement for Automatic disconnection in IT System

(Ref IS 3043:2018 para 23.0.9)

The impedance of the power system earth shall be such that on the occurrence of a single fault to exposed conductive parts or to earth, the fault current is of low value. Disconnection of the supply is not essential on the occurrence of the first fault. Protective measures must, however, prevent danger on the occurrence of two simultaneous faults involving different live conductors.

The following condition shall be fulfilled:

$$R_A \times I_d \leq U_c \dots \dots \dots (3)$$

where

- $R_A$  = resistance of the earthed system for exposed conductive parts,
- $I_d$  = operating currents of the disconnecting series device, and
- $U_c$  = conventional voltage limit.

### 9.0 EARTH FAULT LOOP IMPEDANCE

Impedance/resistance encountered by fault current under earth fault condition is called “**Earth fault loop impedance**” i.e. *the impedance of the earth fault current loop (phase to earth loop) starting and ending at the point of earth fault.* (Ref: IS:3043:2018 para 3.10). This impedance is denoted by the symbol  $Z_s$ .

The earth fault loop comprises the following, starting from the point of fault (Ref: IS:732:2019 para 3.64)

- a) The circuit protective conductor,
- b) The consumer’s earthing terminal and earthing conductor, and for TN systems, the metallic return path,
- c) For TT and IT systems, the earth return path,
- d) The path through the earth neutral point of the transformer,

- e) The transformer winding, and
- f) The line conductor from the transformer to the point of fault.



☞ Whenever fault occurs the current will flow through this fault loop and protection system will be designed accordingly with prospective fault current. This fault current can be calculated with the help of System voltage and Fault loop impedance.

### 9.1 Fault Loop in TN-S System

In TN-S system, the earth fault loop impedance comprises the impedance starting from the point of fault, protective conductor up to source, neutral point of the transformer, transformer winding (involved in faulty circuit) and phase (line) conductor from the transformer to the point of fault. A sample schematic is shown below:

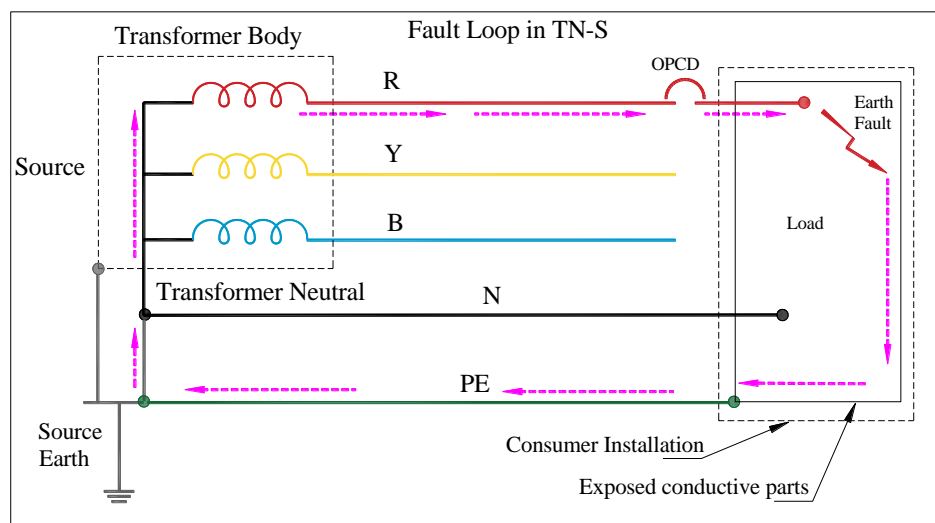


Figure 25: Fault loop impedance circuit in TN-S system

### 9.2 Fault Loop in TN-C System

In TN-C system, the earth fault loop impedance comprises the impedance starting from the point of fault, protective & neutral conductor (PEN) up to source, neutral point of the transformer, transformer winding (involved in faulty circuit) and phase (line) conductor from the transformer to the point of fault. A sample schematic is shown below:

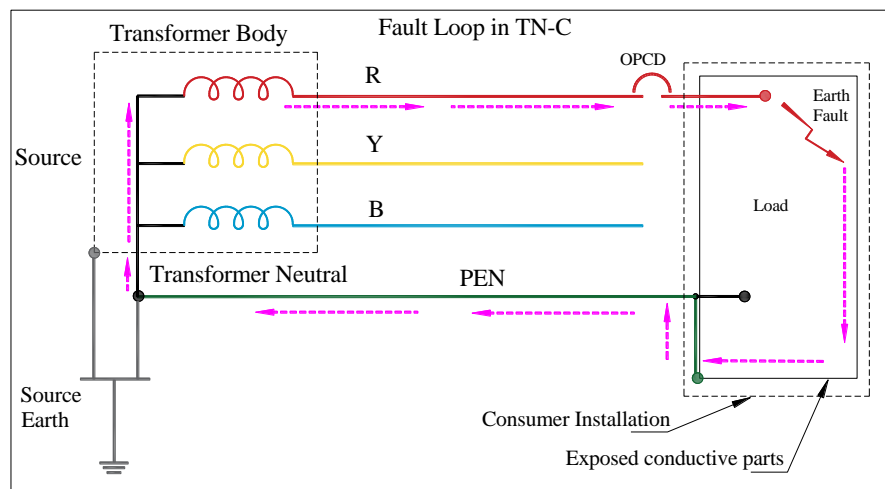


Figure 26: Fault loop impedance circuit in TN-C system



### 9.3 Fault Loop in TN-C-S System

In TN-C-S system, there will be two loops for flow of fault currents, first through the metallic return path i.e PEN conductor & second through the earth (Soil). The magnitude of fault current flowing through the each path will depend on its impedance. Practically the major portion of fault current through the first path i.e PEN conductor. This fault loop impedance in this path comprises the impedance starting from the point of fault, protective conductor (PE) up to MET (Neutral link at main incoming supply), protective & neutral conductor (PEN) up to source, neutral point of the transformer, transformer winding (involved in faulty circuit) and phase (line) conductor from the transformer to the point of fault. The other earth fault loop through installation earth electrode, soil back to source earth electrode. A sample schematic is shown below:

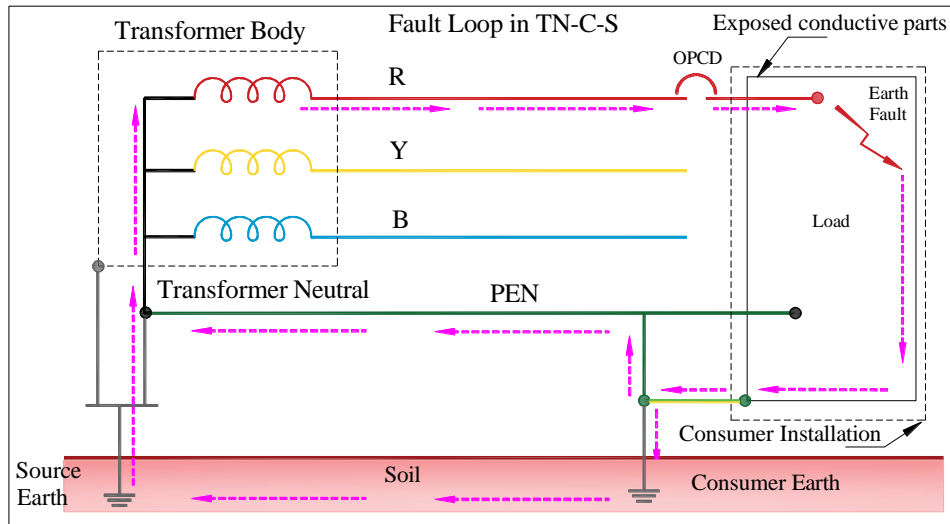


Figure 27: Fault loop impedance circuit in TN-C-S system

### 9.4 For TT System

In TT system, the earth fault loop impedance comprises the impedance starting from the point of fault, circuit protective conductor up to MET, earthing link to installation earth electrode conductor, installation earth electrode, soil path resistance from installation earth electrode to source earth electrode, source earth electrode conductor from source earth electrode to neutral point of the transformer, transformer winding (involved in faulty circuit) and phase (line) conductor from the transformer to the point of fault. A sample schematic is shown below:

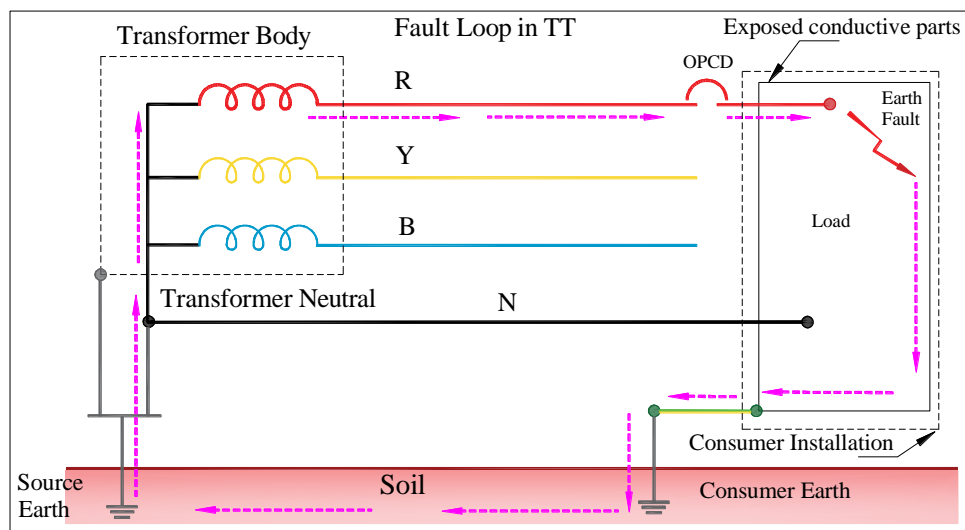


Figure 28: Fault loop impedance circuit in TT system



Earth fault loop impedance tester is used for measurement of earth Fault loop impedance. It is very useful for testing of electrical installations for ensuring the safety.

## 10.0 EARTHING OF INSTALLATIONS

### 10.1 Earthing in Standby Generating Plants (Ref - IS 3043:2018 para 29)

In any low voltage installation where, regular supply is coming from state electricity board and standby supply is being provided by Diesel Generator/ Alternator (DG/ DA) set, earthing of standby generator set is necessary to protect against indirect contact.

The protective earthing conductors are connected as shown in below figure. Generating set metal body, alternator metal frame, neutral point of alternator, metallic cable sheaths and armoring, and all exposed conductive parts of installation (load) are connected by earthing conductors to main earthing terminal (bar) and MET is further connected to earth (normally at one point only). Neutral earthing of DG, earth link of electricity board incoming supply are also connected to **MET** by protective conductors as shown below:

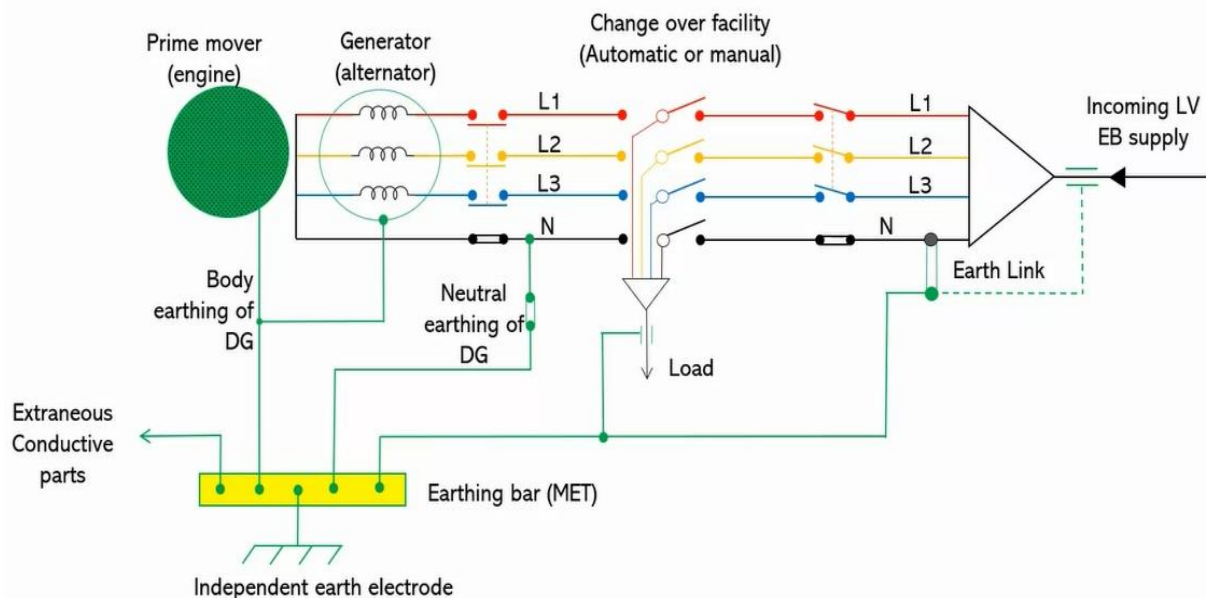


Figure 29: Single Low Voltage Standby Generator (Without paralleling Facility)

- Four-pole changeover switching between the mains and standby, supplies should be used to provide isolation of the generator and electricity board neutral earths. (Ref - IS 3043:2018 para 29.2.2.2)

#### 10.1.1 Unearthed Generators (Rating Below 10 kW) Supplying a Fixed Installation (Ref - IS 3043:2018 para 28.2)

Where an unearthed generator is to supply a fixed installation, for the purpose of protection against indirect contact in case of any earth fault occurs following measure are recommended which will initiate automatic disconnection of supply and isolation of faulty equipment/circuit.

- One pole of a single phase generator should be connected to the installation main earthing terminal.

- b. The installation should be protected by RCDs.
- c. The main earthing terminal should be connected to an earth electrode. The resistance of electrode to earth should sufficiently low to operate the RCDs.
- d. All exposed-conductive parts and all extraneous-conductive-parts in the installation are to be connected to the main earthing terminal.

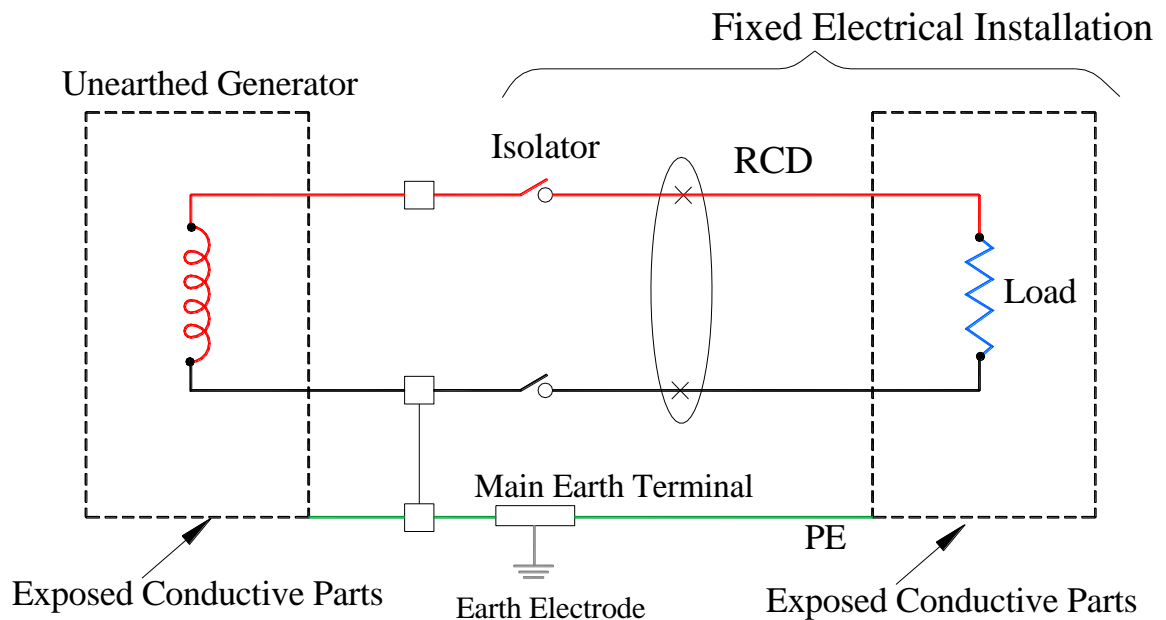


Figure 30: Small low voltage generator supplying a fixed installation

## 10.2 Unearthed Generators Supplying a Mobile or Transportable Unit

(Ref - IS 3043:2018 para 28.3)

Where an unearthed generator is to supply a mobile installation, for the purpose of protection against indirect contact in case of any earth fault occurs following measure are recommended which will initiate automatic disconnection of supply and isolation of faulty equipment/circuit.

- a. One pole of a single phase generator should be connected to the installation main earthing terminal.
- b. All exposed-conductive parts and all extraneous-conductive-parts are to be connected to the main earthing terminal.
- c. The installation should be protected by RCDs.
- d. If the unit supplies equipment or socket outlets outside the unit these circuits should be protected by RCDs with a rated residual operating current not exceeding 30 mA and an operating time not exceeding 40 ms at a residual current of 5 times rated current I.

**If practicable, an earth electrode should be connected to the main earthing terminal of the unit with a resistance to earth sufficiently low to operate the RCDs.**

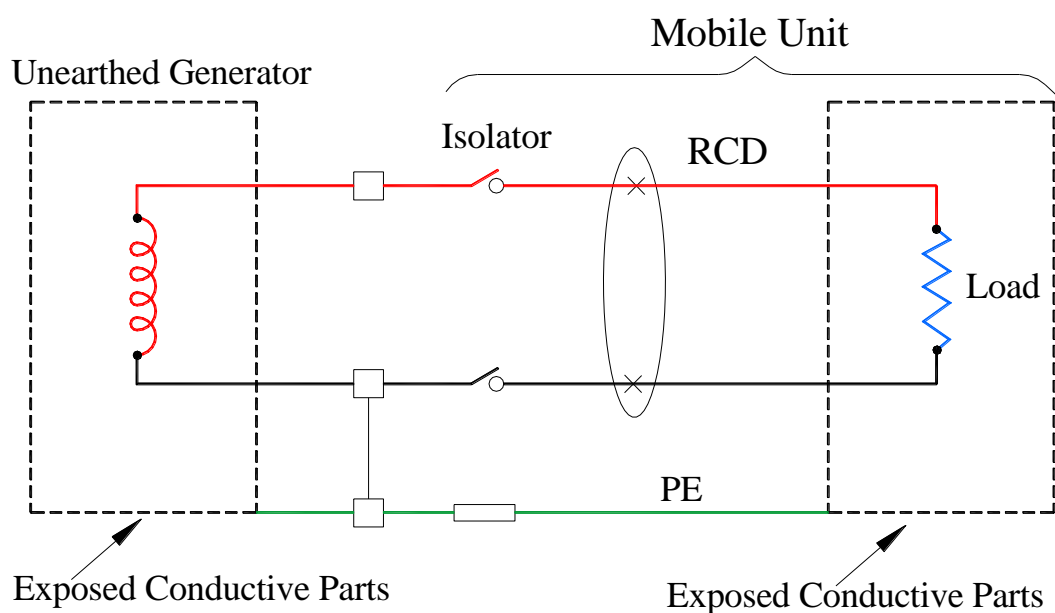


Figure 31: Small unearthed generator supplying a mobile or transportable unit



⚡ The RCD will not provide protection for faults on the generator side of the RCD, and consequently precautions should be taken.

### 10.3 Earthing in Building

(Ref - IS 732:2019 Annex FF)

In any building installation, using LT supply for lighting, air conditioning, heating etc., the entire installation metallic components shall be connected to each other for creating equipotential zone to prevent personnel from shock hazard in case of indirect contact during any earth fault.

All exposed conductive parts of all current using equipment shall be connected to MET via protective earthing conductors through sub distribution boards and main distribution board. All metallic water and waste pipe lines in the bathrooms/ toilet shall be connected through supplementary equipotential bonding terminal (SEBT) by protective bonding conductors and this SEBT is to be connected to MET by protective earthing conductors. All metallic fittings to heating and air-conditioning system (ducts, grills etc.) shall also be connected to MET by protective bonding conductors. Other metallic pipe lines coming to installation and other metallic structures within the building shall be connected to MET by protective bonding conductors.

All protective conductors of sub distribution boards shall be connected to MET through main distribution board. Main distribution board protective conductor may be connected to PE/PEN conductor as per requirement of the system (in case of TN-S to PE or in case of TN-C, TN-C-S to PEN conductor of supply system).

The MET shall be connected to Concrete-embedded foundation earth electrode or soil-embedded foundation earth electrode by earthing conductor.

The down conductor of lightning protection system (LPS) if provided shall be connected to Concrete-embedded foundation earth electrode or soil-embedded foundation earth electrode as well as to earth electrode provided for LPS. An example of earthing arrangements and protective conductors is shown below:

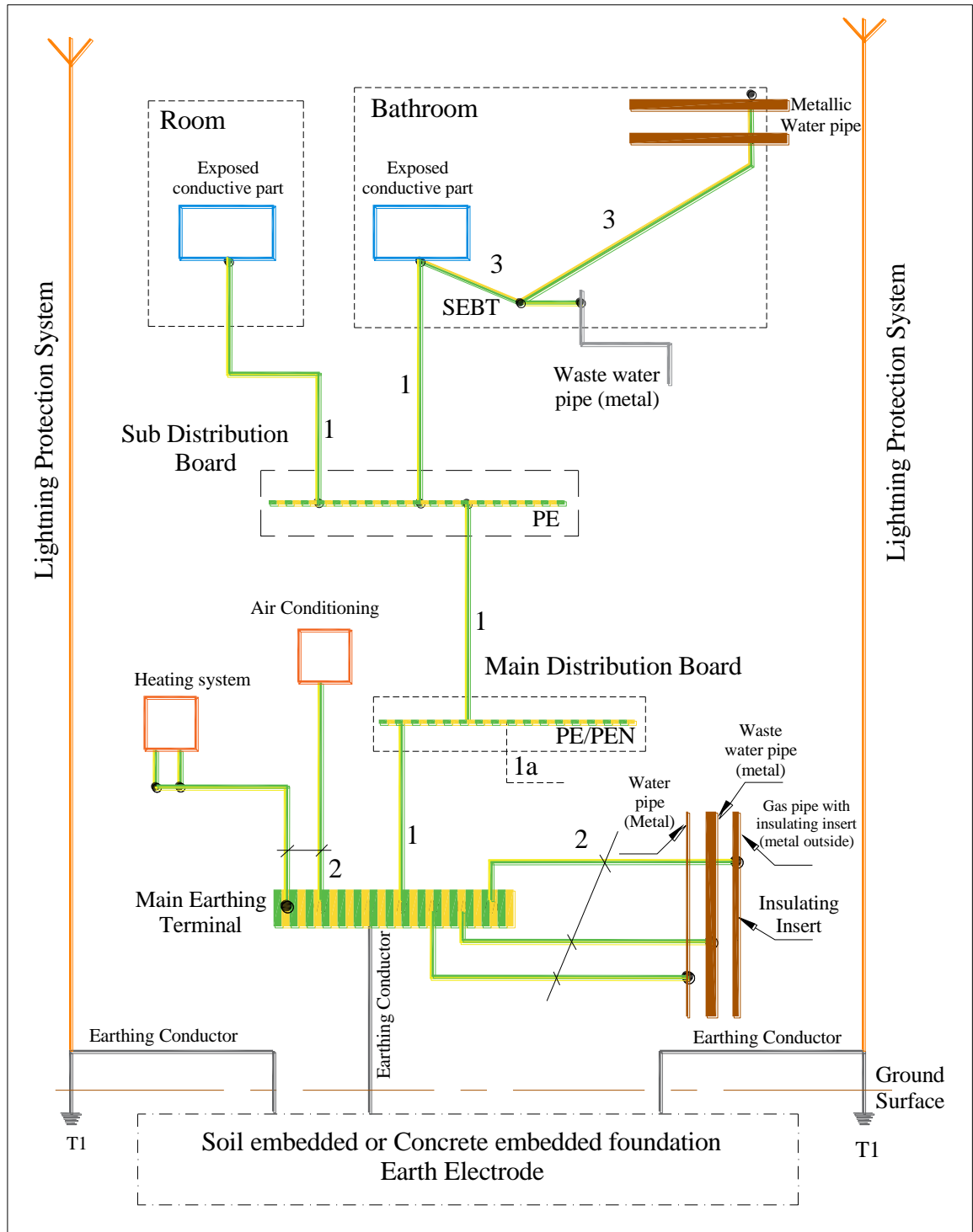


Figure 32: Example of Earthing Arrangements and Protective Conductors

Symbol	Name	Symbol	Name
1	Protective earthing conductor (PE)	T1	Earth electrode for LPS if necessary.
1a	Protective conductor, or PEN conductor, if any, from supplying network	PE	PE terminal(s) in the main distribution board
2	Protective bonding conductor for connection to main earthing terminal.	PE/PEN	PE/ PEN terminal(s) in the main distribution board

3	Protective bonding conductor for supplementary bonding	Extraneous-conductive part (Water pipe, metal from outside, Waste water pipe, metal from outside, Gas pipe with insulating insert, metal from outside)
4	Down conductor of a lightning protection system (LPS) if any.	
5	Earthing conductor	

## 11.0 EARTH ELECTRODES

*“A conductor or group of conductors in intimate contact with and providing an electrical connection to earth”.*(Ref: IS3043:2018 para3.7)

### 11.1 Effect of Shape on Electrode Resistance

(Ref: IS3043:2018 para 14.1)

The greater part of the fall in potential occurs in the soil within a few feet of the electrode surface, since it is here that the current density is highest. To obtain a low overall resistance of the earth the current density should be as low as possible in the medium adjacent to the electrode & it should be so designed as to cause the current density to decrease rapidly with distance from the electrode.

To achieve the above requirement the dimensions (i.e Length, width & thickness) of earth electrode is made large in **one direction** compared with other 2 directions (), thus a **pipe, rod or strip has a much lower resistance than a plate of equal surface area**. However, resistance is not inversely proportional to the surface area of the electrode.

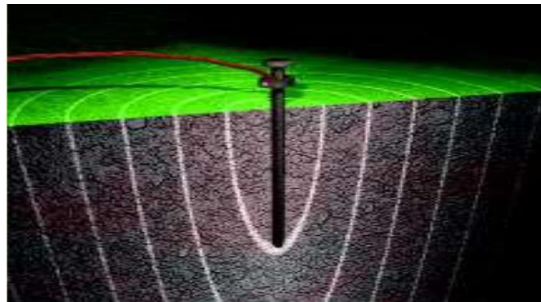


Figure 33: Sphere of Influence Earth Electrode

### 11.2 Multiple Earth Electrodes

In this system more than one electrode is driven into the ground and connected in parallel to lower the resistance. Each earth electrode has its own sphere of influence and for additional electrodes to be effective the spacing of additional rods needs to be at least equal to the depth of the driven rod. Without proper spacing of earth electrodes, the spheres of influence will intersect and the lowering of the resistance will be minimal and of little value.



Figure 34: Spheres of Multiple Earth Electrodes



It is recommended that a drawing showing the main earth connection and earth electrodes be prepared for each installation.

### 11.3 Common Types of Earth Electrodes

#### 11.3.1 Plate electrode

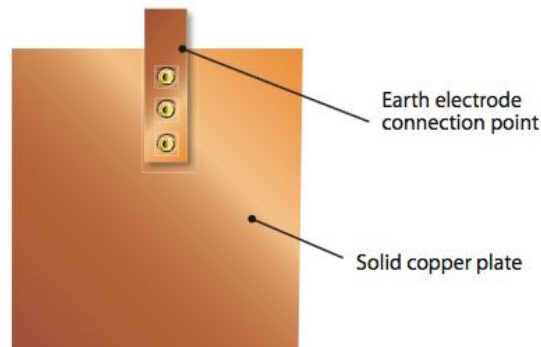


Figure 35: Copper Plate Electrode

According to Cl. 14.2.1 of IS3043-2018, the approximate resistance to earth of a plate can be calculated from:

$$R = \frac{\rho}{4} \sqrt{\frac{\pi}{A}} \Omega$$

where

$\rho$  = resistivity of the soil in  $\Omega$ -m (assumed uniform), and  
 $A$  = area of both sides of the plate (in  $m^2$ ).

Plate electrodes shall be of the size at least 60 cm  $\times$  60 cm. Plates are generally of cast iron not less than 12 mm thick and preferably ribbed. The earth connection should be joined to the plate at not less than two separate points. Plate electrodes, when made of GI or steel, shall be not less than 6.3 mm in thickness. Plate electrodes of Cu shall be not less than 3.15 mm in thickness. Plate electrodes shall be buried such that its top edge is at a depth not less than 1.5 m from the surface of the ground.



The use of coke breeze as an infill is not recommended as it may result in rapid corrosion not only of the electrode itself but also of cable sheaths, etc, to which it may be bonded.

#### 11.3.2 Pipes or Rods electrode

According to Cl. 14.2.2 of IS3043-2018, the resistance of a pipe or rod electrode is given by:

$$R = \frac{100\rho}{2\pi l} \log_e \frac{2l}{d} \Omega$$

Where,

$\rho$  = resistivity of the soil, in  $\Omega$ -m (assumed uniform).

$l$  = length of rod or pipe, in cm,

$d$  = diameter of rod or pipe, in cm,

The earth resistance diminishes rapidly with the first few feet of driving, but less so at depths greater than 2 to 3 m in soil of uniform resistivity. If required to achieve less resistance a number of rods or pipes may be connected in parallel than to increase the length of earth electrode.



Figure 36: Pipe Electrode



Figure 37: Copper Bonded Steel rod Electrode

### 11.3.2.1 Erection of pipe Earth electrode

Construction of pipe electrode along with earth pit shall be as per figure shown below (Fig 25 of IS 3043:2018) all dimensions are in millimetre. The earth fill shall be of homogenous layers of common earth soil (In Earlier version of IS 3043:1987 with amendments the earth fill was a homogenous layer of coke/charcoal, salt). Where soil resistivity is high, earth resistivity enhancement material may be used. Bentonite or similar earth enhancing material may be advantageous in rocky terrain. Bentonite packing will increase the contact efficiency with the general mass of ground.



☞ Copper clad mild steel rods can be used in place of normal mild steel rods where the soil is corrosive.



☞ Mutual separation between multiple earth electrodes of Length (L) should be between L to 2L. In case of mutual separation is not possible between L to 2L, a substantial gain is effected even at 2 m separation.





In case of rocky area where it is difficult to drive the electrode upto required depth or high resistivity soil occur at relatively small depths, considerable advantage may result from driving rods at an angle of about 30° to the horizontal, thus increasing the installed length of electrode for a given depth.

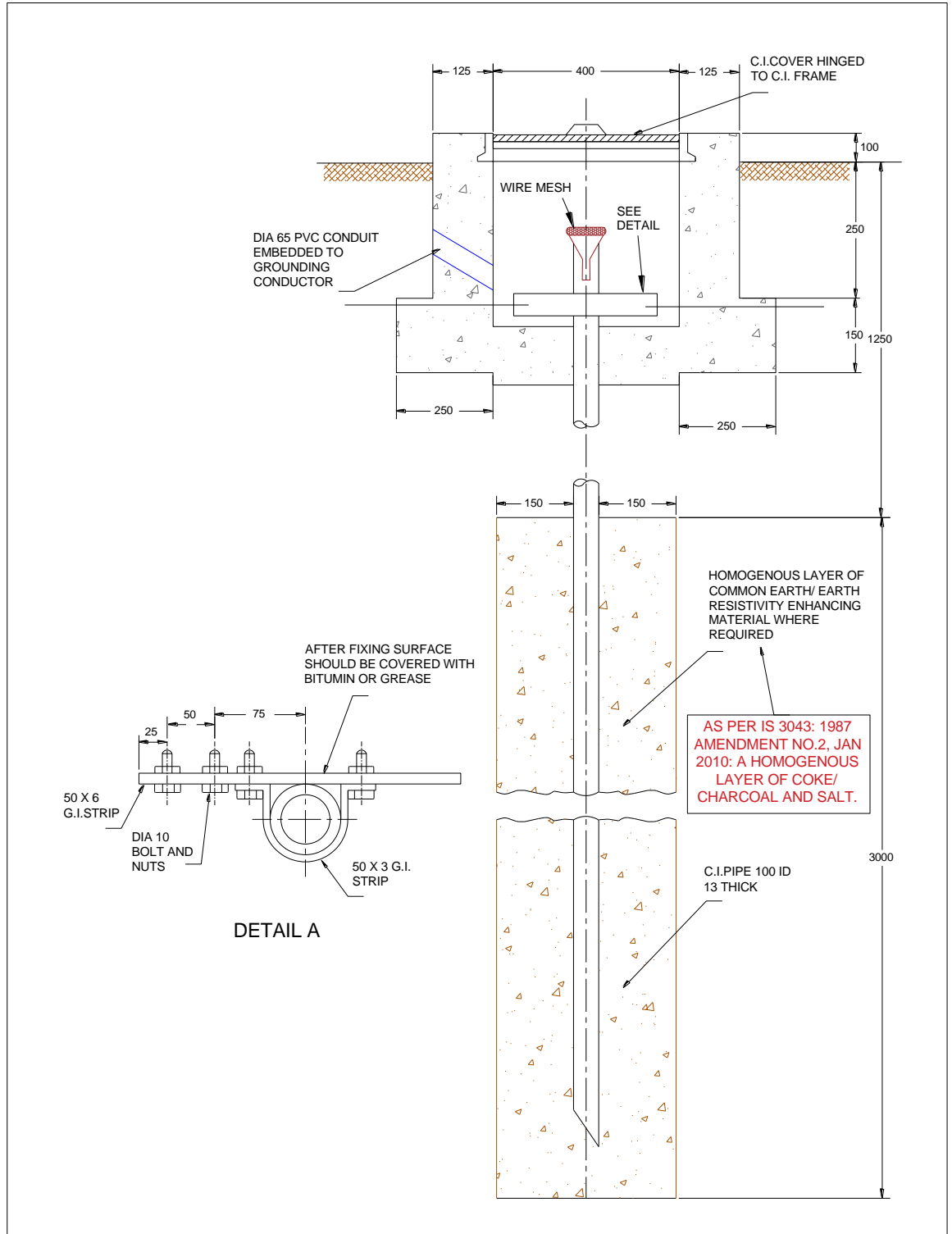


Figure 38: Typical arrangement of pipe electrode (Ref fig 25 of IS 3043:2018)

### 11.3.3 Artificial treatment of soil

(Ref – IS 3043:2018 para 13.8)

In areas of high soil resistivity, and where it is difficult to achieve low resistance to earth even after providing multiple earth electrodes, for such types of locations artificial treatment of soil by adding earth enhancing material can be done.

Such installation requires constant monitoring and replacement of the additives as migration and leaching of applied chemicals over a period of time reduces the efficiency of the system. Chemical treatment of soil also has environmental effects and should not be considered as a long term solution in order to meet a specified level of resistance.

To reduce the soil resistivity of the soil immediately surrounding the earth electrode, alternative earth enhancing material which are easily dissolvable in the moisture (contained in the soil), and are highly conductive may be used. These alternative substances are common salt (sodium chloride = NaCl), calcium chloride (CaCl<sub>2</sub>), sodium carbonate (Na<sub>2</sub>CO<sub>3</sub>), copper sulphate (CuSO<sub>4</sub>), salt & soft coke, and salt & charcoal in suitable proportions. These agents form a conducting electrolyte throughout a wide region surrounding the earth electrode. In using artificial treatment, the possible corrosive effect of the earth enhancing material salt on the driven rods and connections should be considered.

#### 11.3.3.1 Procedure for Artificial treatment

In general when artificial treatment of earth electrode pit is done, it is done by dissolving salt in water and further pouring this solution inside the hollow earth electrode pipe considering that the solution will disperse around the electrode through the perforated earth electrode but this is not the correct practice.

As per IS 3043:2018 para 13.8.1 approximately 90 percent of the resistance between a driven rod and earth lies within a radius of about 2 m from the rod. This should be kept in mind when applying the agents for artificial treatment of soil. The correct & simplest application is by excavating a shallow basin around the top of the rod, 1 m in diameter and about 30 cm deep, and applying the artificial agent in this basin. The basin should subsequently be filled several times with water, which should be allowed each time to soak into the ground, thus carrying the artificial treatment, in electrolyte form, to considerable depths and allowing the artificial agent to become diffused throughout the greater part of the effective cylinder of earth surrounding the driven rod.

#### 11.3.4 Strip or Conductor Electrodes

According to Cl. 14.2.3 of IS3043-2018, the resistance of a strip or conductor electrode is given by:

$$R = \frac{100\rho}{2\pi l} \log_e \frac{4l}{d} \Omega$$

where,

$\rho$  = resistivity of the soil, in  $\Omega$ -m (assumed uniform),

$l$  = length of the Strip in cm, and

$d$  = width (strip) or twice the diameter (conductors) in cm.

Strip or conductor electrode has special advantages where low resistivity soil is at shallow depth and high resistivity soil below surface layers of low resistivity soil. In such cases Plate/pipe/rod electrode will not give satisfactory results. As seen from the graph below, the earth resistance of electrode reduces substantially upto certain length, further increase in length of electrode will not have any significant reduction in earth resistance.

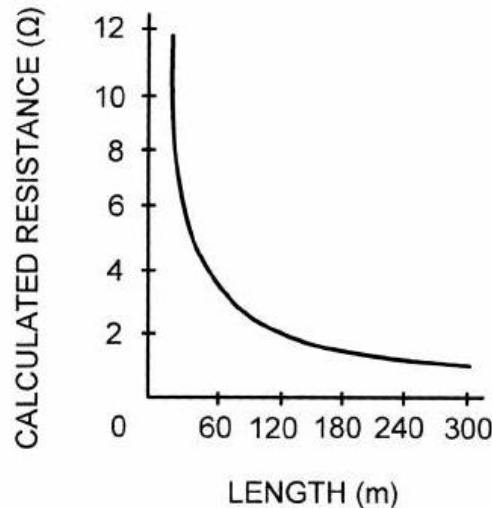


Figure 39: Effect of Length of Strip or Conductor Electrodes In Calculated Resistance For Soil Resistivity Of 100  $\Omega\text{M}$  (Assumed Uniform)

To reduce resistance further strip or conductor electrode may be connected in parallel or they may radiate from a point. In case of parallel connections of two strips at a separation of 2.4 m, the total resistance ( $R_t$ ) will be less than 65% of the individual resistance ( $R$ ) (i.e  $R_t < 0.65R$ )



☞ The care should be taken in positioning of these electrodes so as to avoid damages during civil or agriculture work/operations.

## 11.4 Other Means of Earthing

### 11.4.1 Cable Sheaths

Where an extensive underground cable system is available, the sheath and armour form a most effective earth-electrode. In the majority of cases, the resistance to earth of such a system is less than 1  $\Omega$ . Cable sheaths are more commonly used to provide a metallic path to the fault current returning to the neutral.

### 11.4.2 Structural Steelwork as Earth Electrodes

The resistance to earth of steel frames or reinforced concrete buildings will vary considerably according to the type of soil and its moisture content, and the design of the stanchion bases. For this reason, it is essential to measure the resistance to earth of any structural steelwork that it is employing and at frequent intervals thereafter. These are called as foundation earth electrodes, which is a recommended practice in modern electro-technical standards.

### 11.4.3 Reinforcement of Piles

At power stations and large substations, it is often possible to secure an effective earth-electrode by making use of the reinforcement in concrete piles. The earth strap should be bonded to a minimum of four piles and all the piles between the bonds should be bonded together. Each set of four piles should be connected to the main earthing-strap of the substation.

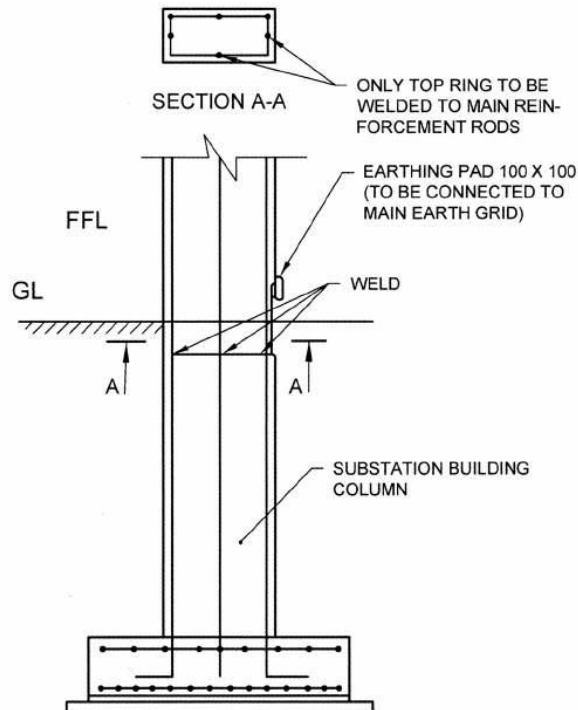


Figure 40: Earthing of Foundation Reinforcement

- Top ring should be half the size of main vertical reinforcement rod and to be welded to main reinforcement rods.
- Earthing Pads should be welded to reinforcement rods and shall be connected to main earth grid.
- Inserts other than earthing pads may or may not be welded to reinforcement.

### 11.4.4 Water Pipes

All Metallic pipe systems of services like water service, flammable liquids or gases, heating systems, etc. **shall not be used as earth electrodes for protective purposes.** For existing installations in which a water pipe is used as a sole earth electrode; an independent means of earthing should be provided at the first practicable opportunity.



Water pipes shall not be used as consumer earth electrodes.

## 11.5 Connections to Earth Electrodes

The materials used for making connections have to be compatible with the earth rod and the copper earthing conductor so that galvanic corrosion is minimized. In all cases, the connections have to be mechanically strong.

For large earthing installations, such as at major substations, it is common to make provision for the testing of earth electrodes. This is achieved by connecting a group of

rod driven electrodes to the main earth grid through a bolted link adjacent to the electrodes in a sunken concrete box. Simpler disconnecting arrangements (or none at all) may be acceptable for small earthing installations.

The connection of an earthing conductor to an earth electrode shall be soundly made and electrically satisfactory. Where a clamp is used, it shall not damage the electrode or the earthing conductor.

A consumer's electrical installation of voltage 250 V but not exceeding 650 V supplied from TN (TN-S, TN-C-S, TN-C) distributor network should have a main earthing terminal (MET) that is connected to the protective conductor of the source and via this to earth electrode installed in the electricity distributor supply system.








As far as possible, all earth connections shall be visible for inspection.




Aluminium or copper clad aluminium conductors should not be used for final connection to earth electrode

## 12.0 EARTHING SYMBOLS

(Ref- IEC 60417)

 5017	<p><b>No.5017 Earth (ground):</b> To identify an earth terminal in cases where neither the symbol 5018 nor 5019 is explicitly stated.</p>
 5018	<p><b>No.5018 Functional Earth:</b> To identify a noiseless (clean) earth terminal, of a specially designed earthing system to avoid causing malfunction of the equipment. (e.g. connection of sensitive electrical equipment of circuits directly to the PE conductor or to a functional earthing conductor (FE), to minimize common mode distribution).</p>
 5019	<p><b>No.5019 Protective Earth:</b> To identify any terminal which is intended for connection to an external conductor for protection against electrical shock in case of a fault, or the terminal of a protective earth electrode. (e.g. protective conductor connecting point to an electrical equipment).</p>
 5020	<p><b>No.5020 Frame or Chassis:</b> To identify a frame or chassis terminal. (e.g. it is a measure to enhance the immunity of the equipment against conducted and radiated RF disturbance. The connection of sensitive electrical circuits to the chassis).</p>
 5021	<p><b>No.5021 Frame or chassis Equipotentiality:</b> To identify the terminals when connected, bring the various parts of an equipment or of a system to the same potential, not necessarily being the earth potential, e.g. for local Equipotential bonding.</p>

	<p><b>No 5173 Signal low terminal:</b> To indicate the signal terminal the potential of which is closest to the earth or chassis potential.</p>
---	---

### 13.0 VOLTAGE GRADIENT AROUND EARTH ELECTRODES

During earth fault conditions, the earth electrode is raised to a potential with respect to the general mass of the earth. This potential can be calculated by the magnitude of fault current and the earth resistance of the electrode (Potential rise = Fault current  $\times$  Earth electrode resistance). This results in the existence of voltages in the soil around the electrode that may be dangerous to livestock.

An effective remedy is **to earth the neutral conductor at some point(PME)** on the system inaccessible to animals rather than earthing the neutral at the transformer itself.

Alternatively, an effective method is for pipe or rod electrodes to be buried with their tops below the surface of the soil and connection made to them by means of insulated leads. The maximum voltage gradient over a span of 2 m adjacent (for a 25 mm diameter pipe electrode) is reduced from 85 percent of the total electrode potential at ground level to 20 and 5 percent when the top of the electrode is buried below 0.3 m and 1.0 m respectively.

Earth electrodes, other than those used for the earthing of the fence itself, should not be installed in proximity to a metal fence, to avoid the possibility of the fence becoming live and thus dangerous at points remote from the substation or alternatively giving rise to danger within the resistance area of the electrode by introducing a good connection with the general mass of the earth.

### 14.0 CURRENT DENSITY AT THE SURFACE OF EARTH ELECTRODE

An earth electrode should be designed to have a current carrying capacity adequate for the system of which it forms a part, that is, it should be capable of dissipating energy without failure. Failure of earth electrode is mainly due to excessive temperature rise at the surface of the electrode and is thus a function of current density and duration as well as electrical and thermal properties of the soil. In general, soils have a negative temperature coefficient of resistance so that sustained current loading results in an initial decrease in electrode resistance and a consequent rise in the earth fault current for a given applied voltage.

Based on experimental studies on the subject by experts at the international level has led to the following conclusions:

- a) Long-duration loading due to normal unbalance of the system will not cause failure of earth-electrodes provided that the current density at the electrode surface does not exceed 40A/m<sup>2</sup>. Limitation to values below this would generally be imposed by the necessity to secure a low-resistance earth.
- b) Time to failure on short-time overload is inversely proportional to the specific loading, which is given by the  $i^2$ , where  $i$  is the current density at the electrode surface. For the soils investigated, the maximum permissible current density,  $i$  is given by:

$$i = \frac{(7.57 \times 10^3)}{\sqrt{\rho t}} \text{ A/m}^2$$

where

$t$  = duration of the earth fault (in s); and

$\rho$  = resistivity of the soil (in  $\Omega \cdot \text{m}$ ).

Experience indicates that this formula is appropriate for plate electrodes.

## 15.0 BASICS OF ELECTRIC CIRCUIT

Let us revise some basics of electrical circuit which will be helpful for understanding better.

### 15.1 Simple Open and Closed Circuit

Current leaves the source and returns to the source. That is called a circuit. If you take a battery (power supply source), the circuit is complete ONLY if you have one part of the circuit connected to the positive and the other side to the negative.



Figure 41: Incomplete circuit or open circuit, no current will flow in above condition.

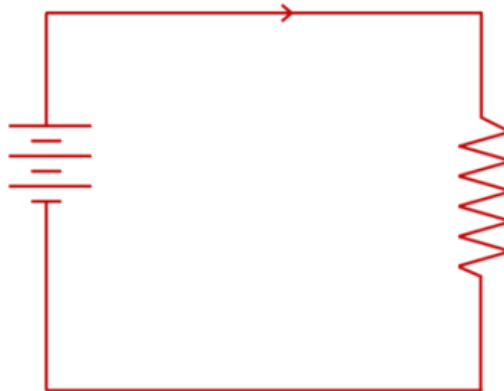


Figure 42: Complete circuit or close circuit, current will flow in this condition according to the source voltage and load resistance.

### 15.2 Open and Closed Circuit with Earth

There is NO circuit if you connect one side to the positive and the other side to ground. Try it. Take a battery and connect positive to the one terminal of the light bulb and connect the other terminal to earth. It will not go on. (Do this with a battery, not a 220 V power supply).

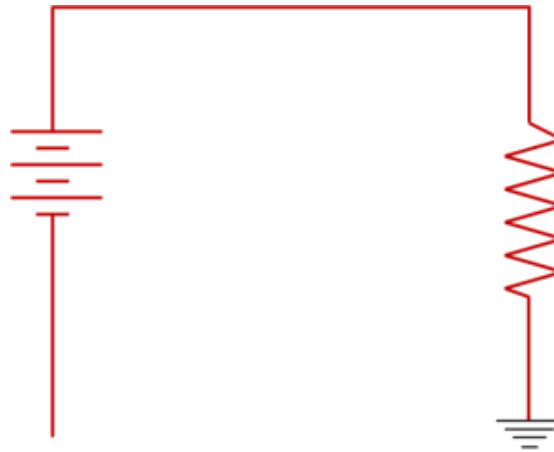


Figure 43: Incomplete circuit or open circuit, no current will flow in above condition.

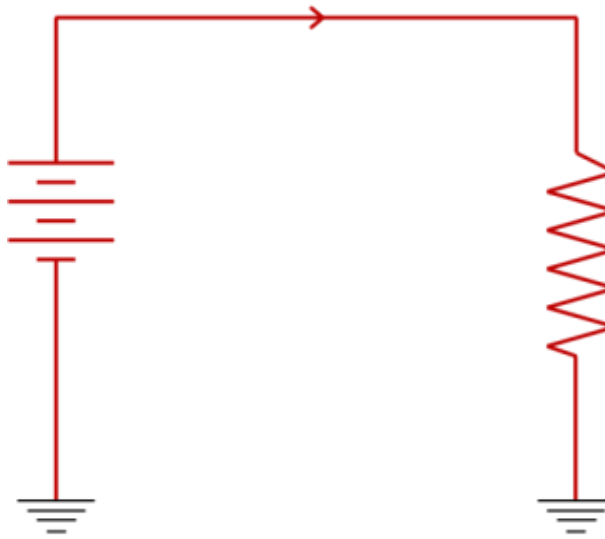


Figure 44: Complete circuit or close circuit, current will flow in this condition according to the source voltage and circuit resistance.



☞ Current does not go to Earth. Current is always trying to make it back to the source.

## 16.0 ELECTRIC SHOCK

(Cl. No. 7 of IS 3043-2018)

### 16.1 Range of Tolerable Current

Effects of an electric current passing through the vital parts of a human body depend on the duration, magnitude, and frequency. The most dangerous consequence of such an exposure is a heart condition known as ventricular fibrillation, resulting in immediate arrest of blood circulation.

A circuit connected to the earthing arrangement (protective equipotential bonding) will protect us from an electrical shock if the supply is disconnected within the recommended time. Connection to earth electrode (plate/pipe/rod) will not protect us from electric shocks. The **ONLY** way to prevent or stop an electric shock is to turn off the circuit before it creates a shock.



## 16.2 Effect of Frequency

Humans are very vulnerable to the effects of electric current at frequencies of 50 Hz. Currents of approximately 100 mA can be lethal. Research indicates that the human body can tolerate a slightly higher 25 Hz current and approximately five times higher direct current.

## 16.3 Effect of Magnitude and Duration of Current Passing through Body

Table 3 : Effect of Magnitude and Duration of Current Passing through Body

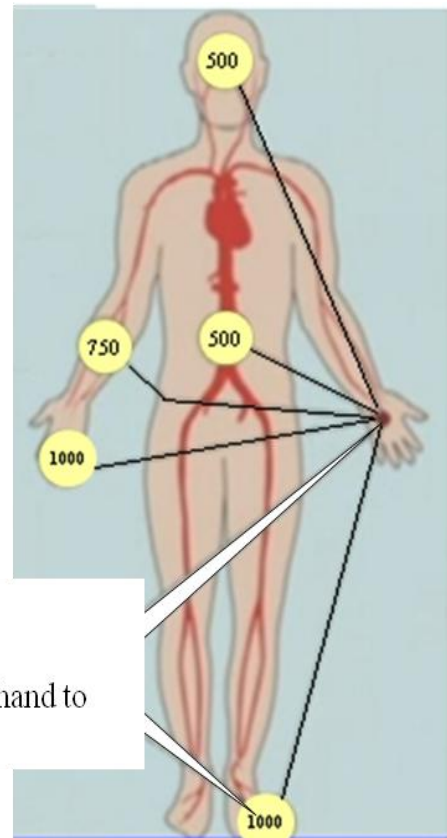
<i>S.no</i>	<i>Current Range</i>	<i>Repercussion on Body</i>
1	1 mA	Threshold of perception; that is, the current magnitude at which a person is just able to detect a slight tingling sensation in his hands or fingertips.
2	1 mA to 6 mA	Let-go currents, though unpleasant to sustain, generally do not impair the ability of a person holding an energized object to control his muscles and release it.
3	9 mA to 25 mA	This currents range may be painful and can make it difficult or impossible to release energized objects grasped by the hand.
4	25mA to 60mA	This currents range could lead to muscular contractions which can make breathing difficult. These effects are not permanent and disappear when the current is interrupted, unless the contraction is very severe and breathing is stopped for minutes rather than seconds.
5	60mA to 100 mA	This currents range may cause ventricular fibrillation, stoppage of the heart, or inhibition of respiration might occur and cause injury or death.

If shock currents can be kept below this value by a carefully designed earthing system by reducing the shock voltage (shock voltage can be reduced by protective equipotential bonding) and duration, injury or death may be avoided. The magnitude and duration of the current conducted through a human body at 50 Hz should be less than the value that can cause ventricular fibrillation of the heart.

## 16.4 Resistance of Human Body

For D.C and 50 Hz A.C currents, the human body can be approximated by a resistance. The current path typically considered is from one hand to both feet, or from one foot to the other one. The internal resistance of the body is approximately  $300\Omega$ , whereas values of body resistance including skin range from  $500\Omega$  to  $3000\Omega$ . The value of resistance of a human body ( $R_B$ ) from hand-to-feet and also from hand-to-hand, or from one foot to the other foot is to be taken as  $1000\Omega$  as per IS 3043-2018.

**The severity of electric shock is dependent on the path through the body it follows and the magnitude of the current flow.**



**Body Impedance  
CEI – 1984**

Resistance in ohms from one hand to various points.

Figure 45: Illustration of body resistance for different part.

**ANNEXURE-I****EARTHING TERMINOLOGY**

(Ref IS 3043:2018 &amp; IS 732:2019)

**i. Arc-Suppression Coil (Peterson Coil)**

An earthing reactor so designed that its reactance is such that the reactive current to earth under fault conditions balances the capacitance current to earth flowing from the lines so that the earth current at the fault is limited to practically zero.

**ii. Bonding Conductor**

A protective conductor providing equipotential bonding.

**iii. Class 0 Equipment**

Equipment in which protection against electric shock relies upon basic insulation; this implies that there are no means for the connection of accessible conductive parts, if any, to the protective conductor in the fixed wiring of the installation, reliance in the event of a failure of the basic insulation being placed upon the environment.

**iv. Class I Equipment**

Equipment in which protection against electric shock does not rely on basic insulation only, but which, includes an additional safety, precaution in such a way that means are provided for the connection of accessible conductive parts to the protective (earthing) conductor in the fixed wiring of the installation in such a way that accessible conductive parts may not become live in, the event of a failure of the basic insulation.

**v. Class II Equipment**

Equipment in which protection against electric shock does not rely on basic insulation only but in which additional safety precautions such as double insulation or reinforced insulation are provided, there being no provision for protective earthing or reliance upon installation conditions.

**vi. Class III Equipment**

Equipment in which protection against electric shock relies on supply at safety extra-low voltage (SELV) and in which voltages higher than those of SELV are not generated.

**vii. Principal Characteristics of Equipment and Precautions for Safety**

Table below gives the principal characteristics of equipment according to this classification and indicates the precautions necessary for safety in the event of a failure of the basic insulation.

Table 4: Equipment Characteristics and Safety Precautions

	<b>Class 0</b>	<b>Class I</b>	<b>Class II</b>	<b>Class III</b>
Principal characteristics of the equipment	No. means for protective earthing	Protective earthing means are provided	Additional insulation and no means for protective earthing	Designed for supply at safety extra low voltage.
Precautions for safety	Earth-free environment	Connection to the protective earthing	None necessary	Connection to safety extra-low voltage

**viii. Dead**

The term used to describe a device or circuit to indicate that a voltage is not applied.

**ix. Double Insulation**

Insulation comprising both basic and supplementary insulation.

**x. Reference Earth**

The conductive mass of the earth, whose electric potential at any point of this mass of earth is taken as zero with reference to an earthing system of electrical power system or electrical installations in a building.

**xi. Earthing System**

Arrangement of connections and devices necessary to earth equipment or a system separately or jointly.

**xii. Global Earthing System**

Equipment earthing system created by the interconnection of local earthing system that ensures, by the proximity of the earthing system, that there is no dangerous touch voltage.

**NOTES**

- 1 Such system permits the devices of the earth fault current in a way that results in a reduction of the earth potential rise at the local earthing system. Such a system could be said to form a quasi-equipotential surface.
- 2 The existence of global earthing system may be determined by simple measurement or calculation for such system. Typical examples of global earthing systems are in city centre, urban or industrial areas with distributed low and high voltage earthing.

**xiii. Earth Electrode**

A conductor or group of conductors in intimate contact with and providing an electrical connection to earth.

**xiv. Earth Grid**

Earth electrode in the form of two overlapping groups of buried, parallel, horizontal electrodes usually laid approximately at right angle to each other with the electrodes bonded at each inter section. Earth grid provides common earth for electrical devices and metallic structures.

**xv. Earth Electrode Resistance**

The resistance to earth of an earth electrode or earth grid.

**xvi. Earth Fault Loop Impedance**

The impedance of the earth fault current loop (phase-to-earth loop) starting and ending at the point of earth fault.

**xvii. Earth Leakage Current**

A current which flows to earth or to extraneous conductive parts in a circuit which is electrically sound.

NOTE — This current may have a capacitive component including that resulting from the deliberate use of capacitors.

**xviii. Earthed Concentric Wiring**

A wiring system in which one or more insulated conductors are completely surrounded throughout their length by a conductor, for example, a sheath which acts as a PEN conductor.

**xix. Earthing Conductor**

A protective conductor connecting the main earthing terminal (or the equipotential bonding conductor of an installation when there is no earth bus) to an earth electrode or to other means of earthing.

**xx. Electrically Independent Earth Electrodes**

Earth electrodes located at such a distance from one another that the maximum current likely to flow through one of them does not significantly affect the potential of the other(s).

**xxi. Equipotential Bonding**

Electrical connection putting various exposed conductive parts and extraneous conductive parts at a substantially equal potential.

NOTE — In a building installation, equipotential bonding conductors shall interconnect the following conductive parts:

- a. Protective conductor;
- b. Earth continuity conductor; and
- c. Risers of air-conditioning systems and heating systems, if any.

**xxii. Exposed Conductive Part**

A conductive part of equipment which can be touched and which is not alive part but which may become live under fault conditions.

**xxiii. Extraneous Conductive Part**

A conductive part liable to transmit a potential including earth potential and not forming part of the electrical installation.

**xxiv. Final Circuit**

A circuit connected directly to current-using equipment or to a socket outlet or socket outlets or other outlet points for the connection of such equipment.

**xxv. Functional Earthing**

Connection to earth necessary for proper functioning of electrical equipment.

**xxvi. Live Part**

A conductor or conductive part intended to be energized in normal use including a neutral conductor but, by convention, not a PEN conductor.

**xxvii. Main Earthing Terminal**

The terminal or bar (which is the equipotential bonding conductor) provided for the connection of protective conductors and the conductors of functional earthing, if any, to the means of earthing.

NOTE —The conductors of the functional earthing may be connected to main earthing terminal (which is the equipotential bonding conductor) only if the same is recommended by original electrical equipment manufacturer.

**xxviii. Neutral Conductor**

A conductor connected to the neutral point of a system and capable of contributing to the transmission of electrical energy.

**xxix. PEN Conductor**

A conductor combining the functions of both protective conductor and neutral conductor.

**xxx. Portable Equipment**

Equipment which is moved while in operation or which can easily be moved from one place to another while connected to the supply.

**xxxi. Potential Gradient (At a Point)**

The potential difference per unit length measured in the direction in which it is maximum.

NOTES

1 When an electric force is due to potential difference, it is equal to the potential gradient.

2 Potential gradient is expressed in volts per unit length.

**xxxii. Earth Potential**

Electric potential with respect to general mass of earth which occurs in, or on the surface of the earth around an earth electrode when an electric current flows from the electrode to earth.

**xxxiii. Earth Potential Rise**

Voltage between an earthing system and reference earth.

**xxxiv. Hot Site**

Substation where the rise of earth potential under maximum earth fault condition can exceed the value either 430V or 650 V depending upon the fault clearance time.

**xxxv. Transferred Potential**

Potential rise of an earthing system caused by a current to earth transferred by means of a connected conductor (for example a metallic cable sheath, PEN conductor, pipeline, rail) into areas with low or no potential rise related to reference earth resulting in a potential difference occurring between the conductor and its surroundings.

NOTES

1 The definition also applies where a conductor which is connected to reference earth, leads into the area of the potential rise.

2 Transferred potential can result in electrocution path through the human body other than the 'touch voltage' path that is hand to hand.

**xxxvi. Protective Conductor**

A conductor used as a measure of protection against electric shock and intended for connecting any of the following parts:

a) Exposed conductive parts,

- b) Extraneous conductive parts,
- c) Main earthing terminal, and
- d) Earthed point of the source or an artificial neutral.

**xxxvii. Reinforced Insulation**

Single insulation applied to live parts, which provides a degree of protection against electric shock equivalent to double insulation under the conditions specified in the relevant standard.

NOTE —The term ‘single insulation’ does not imply that the insulation has to be one homogeneous piece. It may comprise several layers that cannot be tested singly as supplementary or basic insulation.

**xxxviii. Residual Current Device**

A mechanical switching device or association of devices intended to cause the opening of the contacts when the residual current attains a given value under specified conditions.

**xxxix. Residual Operating Current**

Residual current which causes the residual current device to operate under specified conditions.

**xl. Resistance Area (for an Earth Electrode only)**

The surface area of earth (around an earth electrode) on which a significant voltage gradient may exist.

**xli. Simultaneously Accessible Parts**

Conductors or conductive parts which can be touched simultaneously by a person or, where applicable, by livestock.

NOTES

1 Simultaneously accessible parts may be:

- a) live parts,
- b) exposed conductive parts,
- c) extraneous conductive parts,
- d) protective conductors, and
- e) Earth electrodes.

2 This term applies for livestock in locations specifically intended for these animals.

**xlii. Supplementary Insulation**

Independent insulation applied in addition to basic insulation, in order to provide protection against electric shock in the event of a failure of basic insulation.

**xliii. Switchgear**

An assembly of main and auxiliary switching apparatus for operation, regulation, protection or other control of electrical installations.

**xliv. Voltage, Nominal**

Voltage by which an installation (or part of an installation) is designated.

**xliv. Touch Voltage**

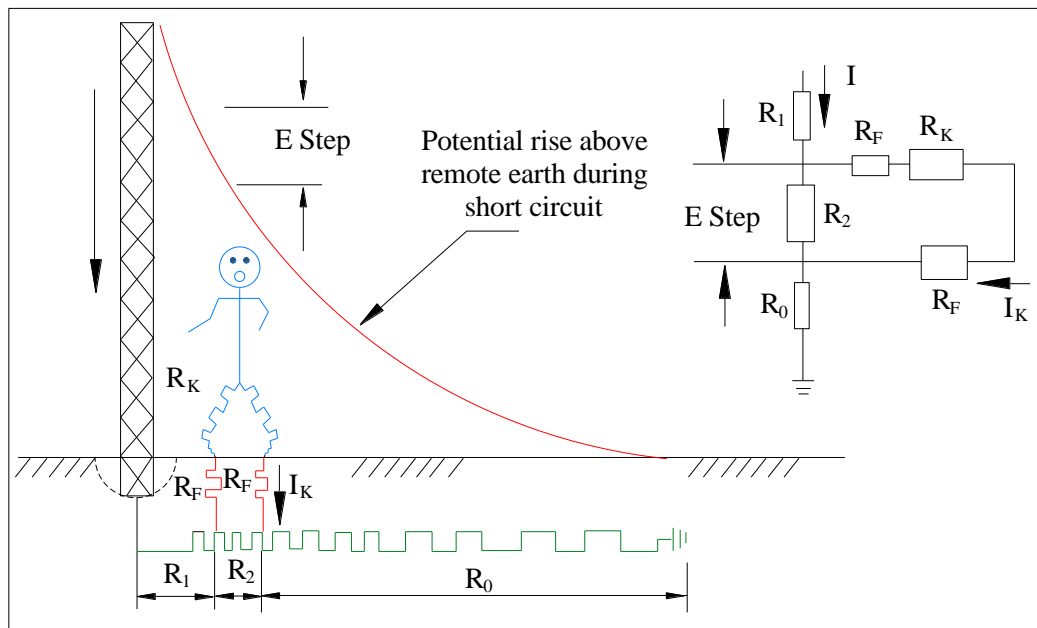
Voltage between conductive parts when touched simultaneously that is the potential difference between an earthed conductor part of equipment, (that is exposed conductive

part) which can be touched and which is not a live part but which may become live under fault condition and a point on a conductive part (that is extraneous conductive part) liable to transmit a potential including earth potential and not forming part of the electrical installation or a point on earth's surface separated by a distance equal to the maximum normal reach (hand to hand or hand to foot) approximately one metre (see Fig. 25).

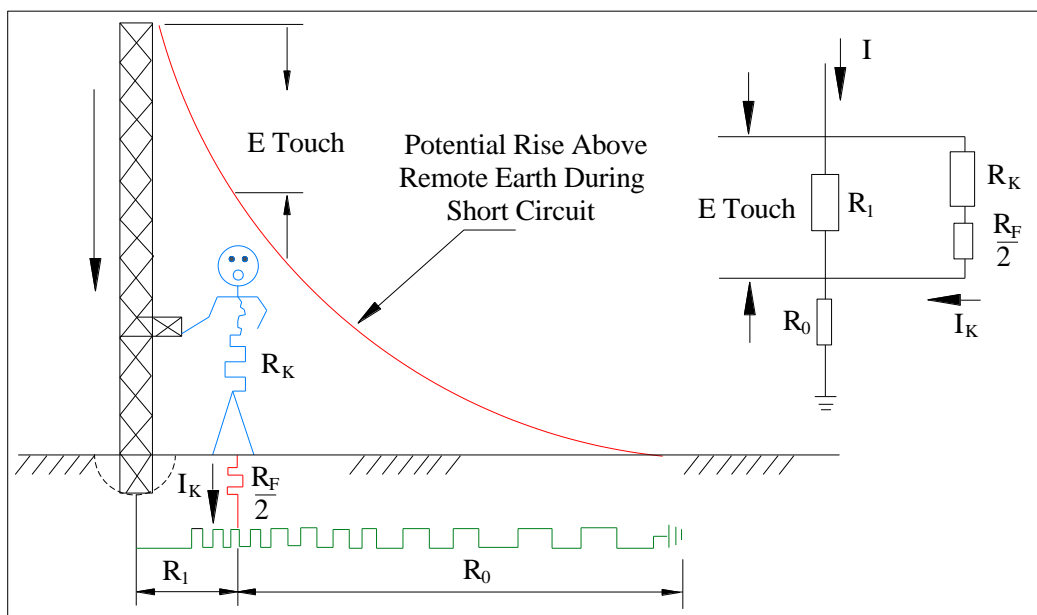
NOTE — The value of the effective touch voltage may be greatly influenced by the impedance of the person in electrical contact with these conductive parts.

**xlvi. Prospective Touch Voltage**

Voltage between simultaneously accessible conductive parts (exposed conductive parts when energised under fault condition and extraneous conductive parts or mass of earth) when those conductive parts are not touched simultaneously by a person.



**Step Voltage at an Earthed Structure**



**Touch Voltage at a Grounded Structure**

Figure 46: Step and Touch Voltages



**xlvi. Step Voltage**

The potential difference between two points on the earth's surface, separated by distance of one pace, that will be assumed to be 1 m in the direction of maximum potential gradient see fig. 25.

**xlviii. Equipotential Line or Contour**

The locus of points having the same potential at a given time.

**xlix. Mutual Resistance of Earthing Electrodes**

Equal to the voltage change in one of them produced by a change of one ampere of direct current in the other and is expressed in ohms.

**i. Earth Grid**

A system of earthing electrodes consisting of inter-connected connectors buried in the earth to provide a common earth for electrical devices and metallic structures.

NOTE — The term 'earth grid' does not include 'earth mat'.

**ii. Earth Mat**

A earthing system formed by a grid of horizontally buried conductors and which serves to dissipate the earth fault current to earth and also as an equipotential bonding conductor system.

## REFERENCES

1. IS 3043-2018: Code of Practice for Earthing (Second Revision).
2. IS 732-2019: Code of Practice for Electrical Wiring Installations (Fourth Revision)
3. IS 9409-1980: Classification of Electrical And Electronic Equipment with Regard to Protection Against Electric Shock
4. Central Electricity Authority (Measures Relating to Safety and Electric Supply), Regulations -2010.
5. IEEMA Journals August, 2020 and October, 2020.
6. “The Missing Link-Guide on Electrical Safety in LV Installation”.

 **NOTE** 



CAMTECH is continuing its efforts in the documentation and up-gradation of information on maintenance practices of electrical assets. Over the years a large number of publications on electrical assets have been prepared in the form of handbooks, pockets books, pamphlets & video films etc. These publications have been uploaded on the internet as well as rail net.

For downloading these publications please do following:

1. On internet visit : [www.rdso.indianrailways.gov.in](http://www.rdso.indianrailways.gov.in)

Go to Directorates → CAMTECH → Other important links  
→ Publications for download → Electrical Engineering

2. On Railnet visit RDSO website at 10.100.2.19

Go to Directorates → CAMTECH → Publications for download  
→ Electrical Engineering

*For any further information regarding publications please contact:*

Dy. Director (Elect.) BSNL:	0751- 2470740 (O)
Rly. :	03747202
	: 9752447030 (CUG)
SSE/Electrical :	9755549297 (CUG)
E-mail :	direlcamtech@gmail.com
Fax :	0751- 2470841
Write at :	Dy. Director (Electrical) Indian Railways Centre for Advanced Maintenance Technology, In front of Hotel Adityaz, Airport Road, Maharajpura, Gwalior, Pin code – 474 005