

Principles and Use of Gears, Shaft & Bearings, Course #600

Presented by:

PDH Enterprises, LLC

PO Box 942

Morrisville, NC 27560

www.pdhsite.com

Gears, shafts, and bearings are the backbone of equipment used in the field of Mechanical Power Transmission. They are the primary components in such things as transmissions, drive trains, and gear boxes. Transmissions and drive trains deliver power from the engine to the wheels of a variety of vehicles ranging from automobiles to earth moving equipment. Gear boxes of a variety of sizes and shapes power the many machines and equipment found in our factories and in our homes.

This course takes the student through the various steps needed to gain valuable insight into the subject matter. The steps include design, types, material/manufacture, load and stress analysis, sample problems, and sketches of actual industrial applications with expert analysis. It is written in an easily understood style with as many images as there are pages of text. Hopefully, the information will aid in encouraging individuals to strive to make innovative improvements in making this planet a better place to live.

This course is written for Mechanical Engineers, Automotive Engineers, Plant Engineers, Civil Engineers, Environmental Engineers, and any other discipline with an interest in Mechanical Power Transmission.

To receive credit for this course, each student must pass an online quiz consisting of twenty (20) questions. A passing score is 70% or better. Completion of this course and successfully passing the quiz will qualify the student for **four (4)** hours of continuing education credit.

Course Author:

Robert Tata, BSME, PE

**Principles and Use of
Gears, Shafts, & Bearings**

**Copyright 2011
Robert P. Tata, B.S.M.E., P.E.
All Rights Reserved**

Introduction

Gears, shafts, and bearings are the backbone of equipment used in the field of Mechanical Power Transmission. They are the primary components in such things as transmissions, drive trains, and gear boxes. Transmissions and drive trains deliver power from engines to the wheels of a variety of vehicles ranging from automobiles to earth moving equipment. Gear boxes of a variety of sizes and shapes power the many machines and equipment that are found in our factories and in our homes.

This course takes the reader through the various steps needed to better understand the function and use of gears, shafts, and bearings and how they work together in the field of Mechanical Power Transmission. The steps include description/design, material/manufacture, load/stress analysis, sample problems, and application in various pieces of industrial equipment with expert analysis. It is written in an easy step-by-step style with as many images as there are pages of text in an effort to be as informative and educational as possible.

Contents

Gears:

Description	4
Terminology	4
Types	7
Material	12
Manufacture	12
Tooth Bending	14
Tooth Pitting	16
Upgrades	16

Shafts:

Description	19
Rim Thickness	19
Design	21

Bearings:

Background	22
Description	22
Loading	22
Material	27
Types	27
Sizes	32
Life	35
Sample Problem	35
Lubrication	36
Closures	37

Applications

Bearings	40
Gears	40

Gears

Description: Gears are one of the most important elements in the field of *Mechanical Power Transmission*. They are round wheel-like shaped components that have teeth equally spaced around the outer periphery. They are used in pairs and are a very valuable design tool. They are mounted on rotatable shafts with the teeth on one gear meshing (engaging) with the teeth on another gear. They are used to transmit rotary motion (rpm) and force (torque) from one part of a machine to another. They have been in existence for thousands of years and are used in everything from watches to wind turbines. Much scientific study, research, and development has been completed on gears. Formulas have been developed and standards established to make gear design and application as easy an endeavor as possible. The gear tooth has been so successfully perfected that, when two gears mesh, almost perfect rolling takes place. Most gears operate in the high 90% efficiency range similar to anti-friction bearings where virtual pure rolling does take place. By changing the diameter of one gear with respect to another, they can be designed to regulate rpm and torque. A gear that is driven by a smaller gear $\frac{3}{4}$ its own size will rotate at $\frac{3}{4}$ the speed of the smaller gear and deliver $\frac{4}{3}$ the torque as seen on Figure 1 between the drive and idler gears. The idler gear, having the same number of teeth as the driven gear, serves only to change the direction of rotation between the drive gear and the driven gear. Precaution has to be taken when using idler gears because the teeth undergo reverse bending which shortens their lives compared to the drive and driven gears where only single-direction bending takes place. The advantageous use of gears is exhibited in the transmission of an automobile where they are used to power the vehicle in a very smooth and efficient manner.

Terminology: The gear is one component of mechanical power transmission systems that does not lack for descriptive terminology: (See Figure 2.)

- *Pinion* is the smaller of two gears in mesh. The larger is called the *gear* regardless of which one is doing the driving.
- *Ratio* is the number of teeth on the gear divided by the number of teeth on the pinion.
- *Pitch Diameter* is the basic diameter of the pinion and the gear which when divided by each other equals the ratio.

Figure 1

Gears Delivering
Motion and Force

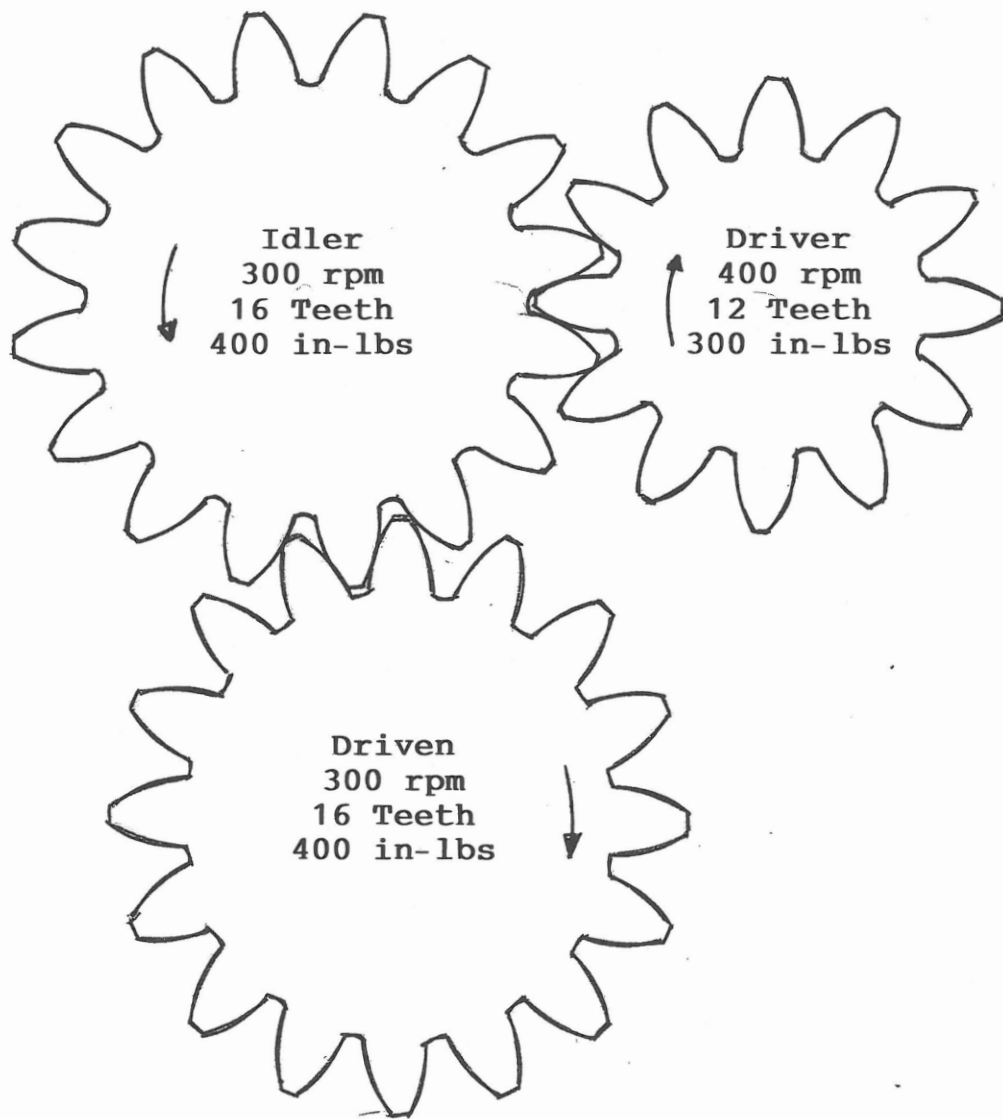
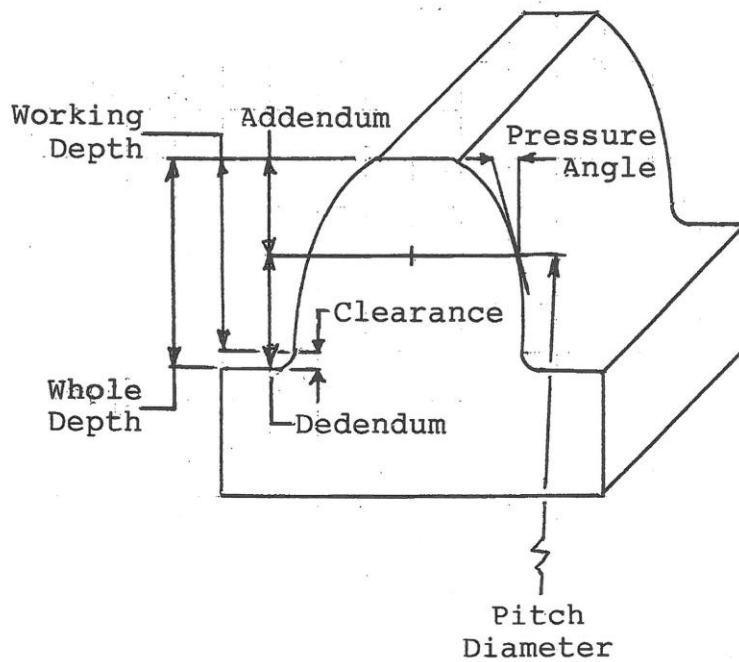

Figure 2

Gear Tooth Terminology



Dimensions For a 2 Diametral Pitch Tooth:

- Addendum = $1.00/2 = 0.500$ inches
- Dedendum = $1.25/2 = 0.625$ inches
- Clearance = $0.25/2 = 0.125$ inches
- Whole Depth = $2.25/2 = 1.125$ inches
- Working Depth = $2.00/2 = 1.000$ inches

- *Diametral Pitch* is a measure of tooth size and equals the number of teeth on a gear divided by the pitch diameter in inches. Diametral pitch can range from $\frac{1}{2}$ to 200 with the smaller number indicating a larger tooth. (See Figure 3.)
- *Module* is a measure of tooth size in the metric system. It equals the pitch diameter in millimeters divided by the number of teeth on a gear. Module equals 25.4 divided by the Diametral pitch. Module can range from 0.2 to 50 with the smaller number indicating a smaller tooth.
- *Pitch Circle* is the circumference at the pitch diameter.
- *Circular Pitch* is the distance along the pitch circle from a point on one gear tooth to a similar point on an adjacent gear tooth.
- *Addendum* of a tooth is its radial height above the pitch circle. The addendum of a standard proportion tooth equals 1.000 divided by the diametral pitch. The addendum of a pinion and mating gear are equal except for the long addendum design where the pinion addendum is increased while the gear addendum is decreased by the same amount.
- *Dedendum* of a tooth is its radial depth below the pitch circle. The dedendum of a standard proportion tooth equals 1.250 divided by the diametral pitch. The dedendum of a mating pinion and gear are equal except in the long addendum design where the pinion dedendum is decreased while the gear dedendum is increased by the same amount.
- *Whole Depth* or total depth of a gear tooth equals the addendum plus the dedendum. The whole depth equals 2.250 divided by the diametral pitch.
- *Working Depth* of a tooth equals the whole depth minus the height of the radius at the base of the tooth. The working depth equals 2.000 divided by the diametral pitch.
- *Clearance* equals the whole depth minus the working depth. The clearance equals the height of the radius at the base of the tooth.
- *Pressure Angle* is the slope of the tooth at the pitch circle.

Types: Four basic types of gears commonly used are: *spur*, *helical*, *bevel*, and *spiral bevel*. (See Figure 4.) A spur gear has teeth that are uniformly spaced around the outer surface. The teeth are aligned in a direction that is parallel to the gear axis. They are designed to mesh with another spur gear on a parallel shaft. They impose radial loads only (perpendicular to the gear axis) on the shaft. They are the most common type of gear used today. There are a number of different ways to machine and finish spur gears making them the most economical choice.

Figure 3

Gear Tooth Sizes
14.5° Pressure Angle

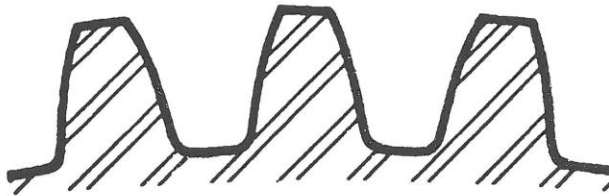

Three Diametral Pitch

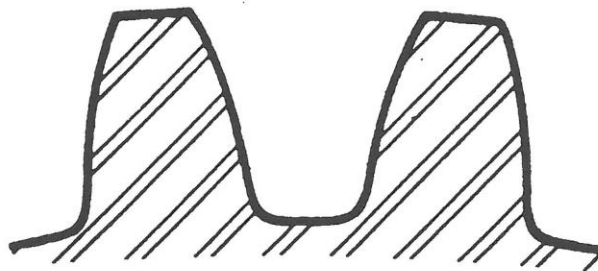

Two Diametral Pitch

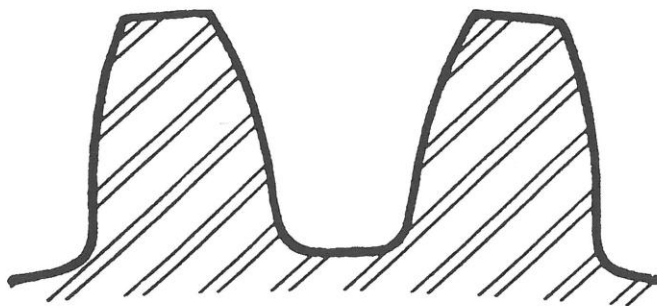

One & Three-Fourths Diametral Pitch

Figure 4
Types of Gears

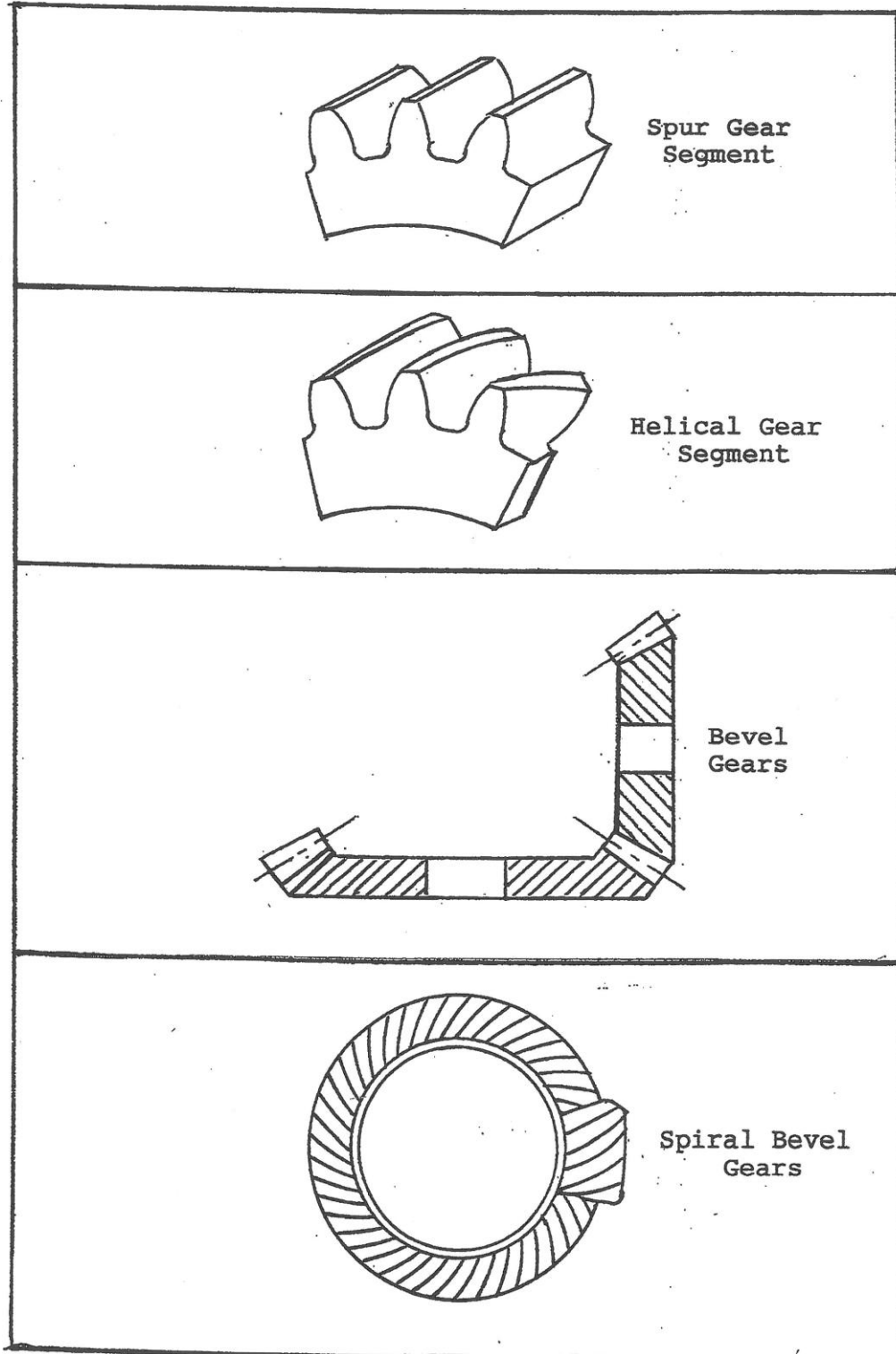

The cross-sectional (normal) shape of each of the two faces of a spur gear is in the form of an *involute* curve. An involute curve is the shape generated by the end of a string that is unwound from a cylinder as shown by the sketch at the top of Figure 5. The sketch at the bottom of Figure 5 indicates the *line of action* of two engaging teeth. The line of action is the path taken by the mating point between two teeth from the start of contact to the end of contact. The line of action is tangent to the *base circle* (cylinder) of each gear. Contact is first made at the base of the driving gear tooth and near the tip of the driven gear tooth. As the contact progresses along the line of action, it moves to the top of the driving tooth and to the base of the driven tooth. This action is in the direction of unwinding the end of the string of the driving gear from around the base cylinder (base circle) and, at the same time, winding the end of the string around the base cylinder of the driven gear. It results in more rolling and less sliding between engaging teeth and produces a constant angular velocity. The efficiency of mating spur gears is in the high 90% range which approaches that of anti-friction bearings. In most cases, at the beginning and end of contact, there are two sets of teeth sharing the load while, near the center of the line of contact, there is only one set of teeth carrying the load. If there were only one set of teeth in engagement over the entire line of contact, full load would be taken near the tips of both the driving and driven gears shortening the life of the gearset. The average number of teeth in engagement at any one time is called the *contact ratio*. A contact ratio of 1.5 does not infer that there are one and one-half teeth in engagement at all times. It indicates that, on the average, there are between one and two teeth in engagement at any one time.

Helical gears are like spur gears except that, instead of the teeth being parallel to the gear axis, they are aligned at an angle across the outer surface of the gear. The angle is called the helix angle and normally runs from 10° to 30° . They are usually made with the involute profile in the transverse section (perpendicular to gear axis). With spur gears, the mating teeth mesh along their entire width. With helical gears, the contact begins at one end of the tooth and then traverses diagonally across the width of the tooth to the other end. Because of this, helical gears run smoother and quieter than spur gears and can carry a higher load but at a lower efficiency. Because the teeth mesh across a diagonal line, helical gears impose both radial and thrust loads on the shaft. This can be eliminated by mounting two helical gears together with the teeth opposing each other. This arrangement is called *double helical* or *herringbone*.

Figure 5

Shape of Gear Teeth

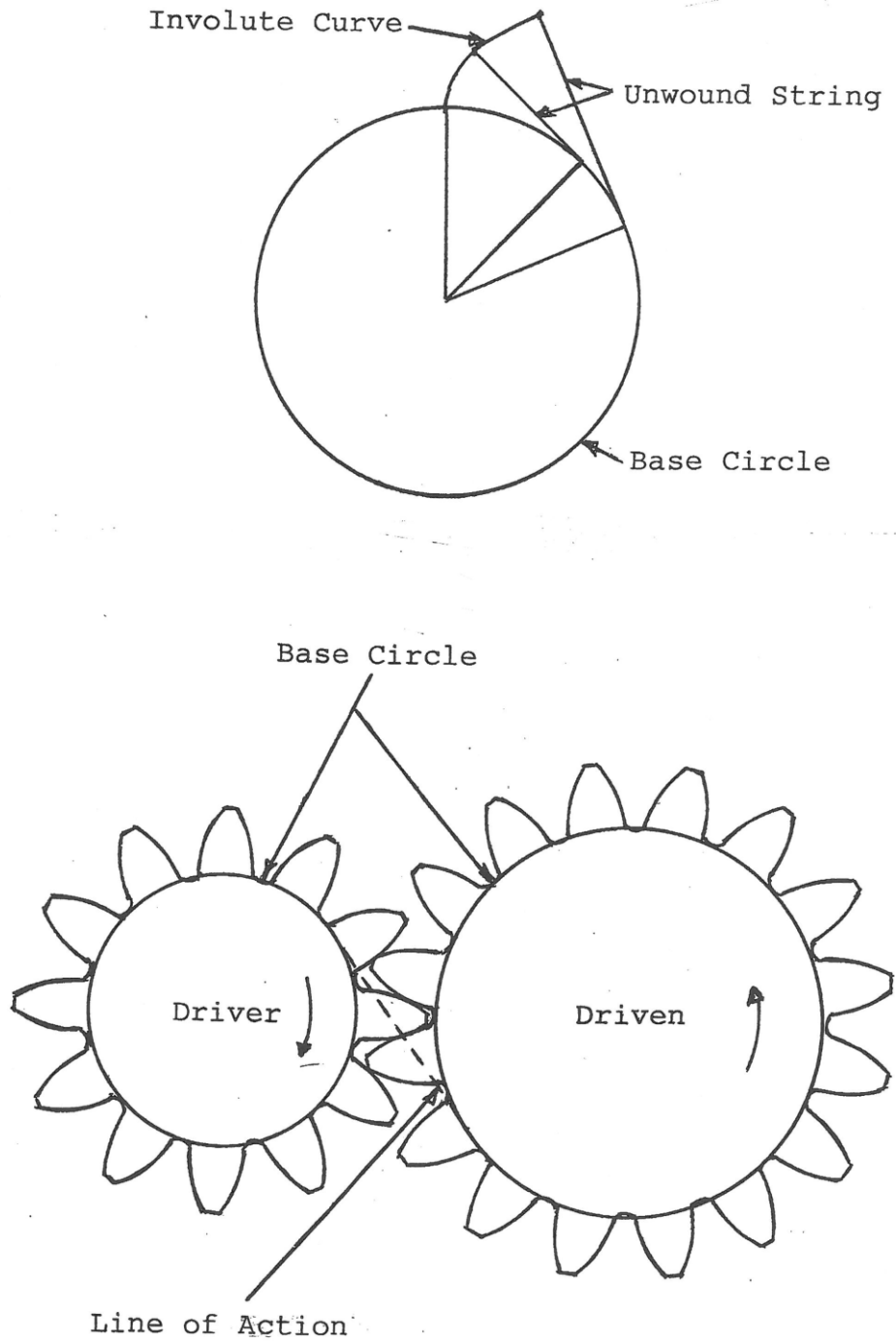

Bevel gears are used to transmit speed and torque between two shafts that are not parallel but are at an angle to each other such as 90°. Bevel gear teeth are smaller at one end than at the other, and, like spur gears, operate in the high 90° efficiency range. Bevel gears with angled teeth are called spiral bevel gears. Spiral bevel gears are similar to bevel gears as helical gears are to spur gears. Spiral bevel gears whose axes do not intersect are called hypoid gears. Hypoid gears are used in the drive axles of automobiles to lower the drive shaft and allow more passenger space.

Material: Gears can be manufactured out of steel, iron, bronze, and plastic. Steel is the most widely used gear material. Iron is sometimes used and has good castability properties. Bronze is good when friction is a concern. Plastic gears have good moldability properties but have limited load carrying capacity. Many different alloys of steel can be used for gears. They range from low carbon, low alloy to high carbon, high alloy. Low carbon, low alloy steel gears cost less but do not perform as well as high carbon, high alloy steel. Gear steel is available in grades 1, 2, and 3 as classified by the American Gear Manufacturers Association (AGMA) in Standard ANSI/AGMA 2001-D04. Higher grade numbers represent higher quality steels for higher performing gears.

Steel gears can be heat treated to improve performance by increasing strength and wear properties. Some alloys are thru-hardened to the Rockwell C42 level, while others are carburized and hardened to the Rockwell C60 level on the outer case while leaving the inner core softer. This hardening technique called *case-hardening* gives good strength and wear properties to the outer layer while the softer inner core gives good shock absorbing characteristics.

Manufacture: Machining processes for most gears can be classified as either *generating* or *forming*. The generating method involves moving the tool over the work piece in such a way as to create the desired shape. In the forming process, the shape of the tool is imparted on the work piece. A generating method of cutting gear teeth that is commonly used is called *hobbing*. A hob is a thread-like cutting tool that has a series of notches machined across it to provide cutting surfaces. A hob can be fed across, tangentially, or radially into the gear blank developing several teeth at the same time. Forming methods of gear cutting include *shaping* and *milling*.

Shaping uses a gear-like tool that is reciprocated up and down to impart its tooth form on the gear blank. Milling uses a shaped tool that is rotated to remove metal between the gear teeth.

After cutting, some gears are heat treated to increase strength and durability. This process causes a small amount of distortion. In order to restore good tooth accuracy and surface finish, heat treating is followed by a *finishing* operation. For gears that are heat-treated to a hardness level of RC42, a finishing operation called *shaving* is performed. Shaving is similar to shaping except that the tool teeth are grooved to provide additional cutting edges to remove only a small amount of material. For gears that are heat treated to a hardness level over RC42, *grinding* is used as the finishing operation. Grinding can be either a generating or forming method of finishing gears. The generating method passes an abrasive wheel over the gear teeth in a prescribed manner to true up the teeth and produce a fine surface finish. The forming method feeds a shaped wheel between the gear teeth similar to milling.

Gears can be manufactured over a very large size range. They can be from a fraction of an inch in diameter to many feet in diameter. Gear tooth height can range from .001 inch (200 diametral pitch) to 4.31 inch ($\frac{1}{2}$ diametral pitch). Metric tooth height ranges from .431 millimeters (0.2 module) to 107.85 millimeters (50 module).

Popular pressure angles for gear teeth are 14.5° , 20° , and 25° . As the pressure angle increases, the teeth become wider at the base and narrower at the tip. This makes the tooth stronger in bending and able to carry more load but more apt to chip at the tip if not properly designed. Pinions with higher pressure angles can be made with fewer teeth because of there being less danger of undercutting. Undercutting is an undesirable narrowing of the base of teeth when being manufactured because of inadequate tool clearance. Lower pressure angle teeth have a narrower base thus carry less load than higher pressure angle teeth but the teeth are wider at the tip and less apt to chip. Finally, lower pressure angle teeth run smoother and quieter than higher pressure angle teeth because of having higher contact ratios.

Gear Tooth Bending: *Wilfred Lewis* calculated gear tooth bending strength in 1892. He was the first to treat the gear tooth as a cantilever beam. He conceived the idea of inscribing the largest parabola that would fit inside a gear tooth. Using the appropriate cantilever beam equation, he then calculated the stress which is constant all along the contour of the parabola. The weakest part of the tooth is where the parabola is tangent to the surface of the gear tooth. This point occurs near the base of the tooth where the involute curve meets the fillet radius. (See Figure 6.) The magnitude and location of the maximum bending stress on the tooth are now known. AGMA base their gear tooth bending stress power rating formula on the work of Lewis in Standard ANSI/AGMA 2001-D04. As a sample problem, the bending strength power rating formula found in this Standard will be used to evaluate an industrial gearset with the pinion having 35 teeth and the gear having 55 teeth. The diametral pitch will be 7 and the pressure angle will be 14.5°. For the sake of brevity, the formula modifying factors such as for overload and temperature will be assumed to be 1. In actual practice, they must all be used. The formula transposed down to one line is as follows:

$$P_{at} = (\pi n_p d F J s_{at}) / (396,000 P_d)$$

P_{at} is the tooth bending strength allowable transmitted horsepower for 10 million cycles of operation at 99% reliability. π (pi) is a constant and equals 3.142. n_p is the pinion speed which will be assumed to be 1000 rpm. d is the pinion pitch diameter which equals 5.000 inches (35/7). F is the face width and, as a general rule of thumb for industrial gearing, equals d . J is the tooth geometry factor and from AGMA Standard ANSI/AGMA 908-B89 equals .30 for the pinion and .31 for the gear. The .30 value for the pinion will be used since it will yield the more conservative number. The tooth geometry factor takes into account the shape of the tooth, the worst load position, and stress concentration which is dependent upon the size of the fillet radius at the base of the tooth. s_{at} is the allowable bending stress and will be assumed to be 55,000 psi for case-hardened grade 1 steel material as found in the reference mentioned above. P_d is the diametral pitch and, as stated above, equals 7. Inserting these values into the above formula reveals that the sample gearset has a tooth bending strength allowable transmitted rating of 468 horsepower.

Figure 6

Gear Tooth Bending Stress

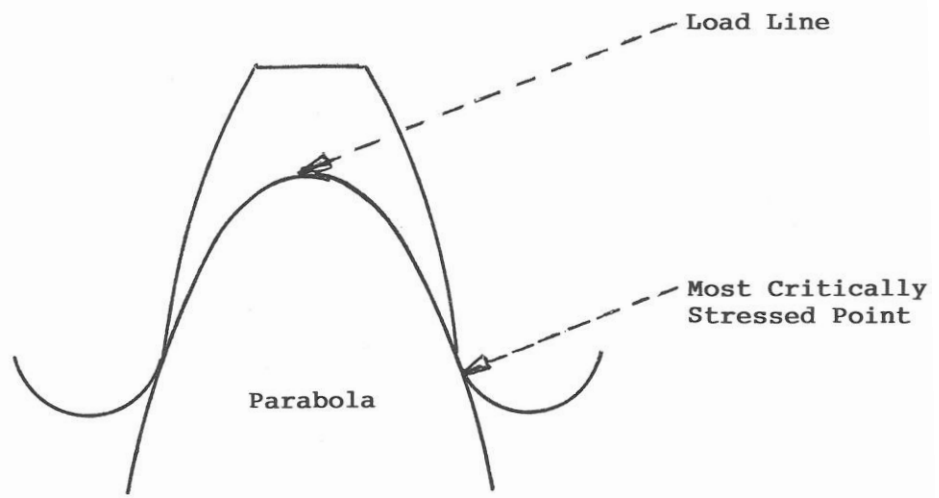

Lewis Method for Calculating
Gear Tooth Bending Stress

Gear Tooth Pitting: The stress on the contact area of gear teeth is based on the work of German physicist Heinrich Hertz. He determined the stress and shape of the contact pattern between various geometric figures. Of interest for gear work is the stress and contact pattern between two parallel cylinders which simulates the condition existing between two mating gear teeth. AGMA bases their gear pitting resistance power rating formula on the work of Hertz, which is also found in Standard ANSI/AGMA 2001-D04. As a comparison, this pitting resistance power rating formula will be used to compare the results to the tooth bending formula. The formula follows:

$$P_{ac} = (\pi n_p F I / 396,000) (d s_{ac} / C_p)^2$$

P_{ac} is the pitting resistance allowable transmitted horsepower for ten million cycles of 99% reliability. π (pi) is a constant and equals 3.142. F is the face width of the gears and equals 5.000 inches. I is the geometry factor for pitting which from AGMA equals .074. I is dependent on the radius of curvature of the two contacting surfaces and load sharing. d is the pinion pitch diameter and also equals 5.000 inches. s_{ac} equals the allowable contact stress from AGMA and equals 180,000 psi for case-hardened grade 1 steel. C_p is the elastic coefficient and from AGMA equals 2300 psi⁵ for a steel pinion and gear. Inserting these values into the above formula reveals that the sample gearset has a pitting resistance allowable transmitted rating of 450 horsepower. Since the pitting horsepower number is lower than the bending number, the pitting number is used to rate the gearset.

Performance Upgrades: As previously mentioned, higher pressure angle teeth are wider at the base making them stronger in bending strength than lower pressure angle teeth. In addition, higher pressure angle teeth have a larger radius of curvature at the contact area reducing the compressive pitting stress. The previous bending and pitting formulas were calculated using 14.5° teeth. Now the same calculations will be made using a 25° pressure angle gearset. When this is done, the only items that change in the two horsepower equations are the tooth geometry factors for bending and for pitting. The new geometry factors for 25° pressure angle teeth are .47 for tooth bending and .112 for tooth pitting which increases the bending allowable rating to 733 horsepower and the pitting allowable rating to 681 horsepower, an increase of 57% and 51% respectively. Higher pressure angle teeth show significant gains in horsepower with the gains being slightly higher in bending than in pitting.

Normally in a gearset, the pinion is weaker than the gear. In order to equalize the strength of the two, a tooth modification factor called *long addendum* is used. In the long addendum design, the pinion addendum is increased while the gear addendum is decreased by the same amount. This increases the pinion bending strength and also reduces the compressive stress that cause pitting failures. In the sample problem, the gearset incorporated the 100% standard length pinion and gear addenda. Now the same formulas will be used for a 150% long pinion addendum design. Again, the only item that changes in the formulas is the tooth geometry factor for both bending and pitting. The new factors are .39 for bending and .078 for pitting increasing the bending rating to 608 horsepower and the pitting rating to 474 horsepower, an increase of 30% and 5% respectively. It can be seen that the long addendum horsepower increases are much higher for bending then for pitting. Since the long addendum design is easy to accommodate in manufacturing, it is a convenient engineering design tool to use especially when increases in bending horsepower are needed more than increases in pitting horsepower. Although it can be used in this gearset, it cannot be used in all applications because of the teeth becoming too pointed and prone to chipping especially with higher pressure angle pinions with a lower number of teeth.

The preceding examples were calculated using grade 1 steel. Now the formulas will be used for evaluation of higher grade 3 steel. The items that change are the allowable bending stress which increases from 55,000 psi for case-hardened grade 1 steel to 75,000 psi for case-hardened grade 3 steel and the allowable pitting contact stress which increases from 180,000 psi for case-hardened grade 1 steel to 275,000 psi for case-hardened grade 3 steel. Grade 3 steel yields gains of 36% (638 hp) for bending and 133% (1050 hp) for pitting. The high pitting gains are attributed to the large increase in the allowable contact stress numbers listed above which are taken to the second power in the formula.

The three gearset performance upgrades can be combined for an overall increase of 154% (1190 hp total) for bending and 272% (1674 hp total) for pitting. The gearset would then be rated at 1190 horsepower since it is the more conservative number. The above examples demonstrate the options that the designer has available to increase the horsepower output of gearsets should the need arise.

Another consideration in the design of gearsets is the *hunting ratio*. The hunting ratio is the ratio that insures that any tooth in one gear will contact, in time, all the teeth in the mating gear. This tends to equalize wear and improve tooth spacing especially with lower hardness steel. The test for a hunting ratio is that the number of teeth in the pinion and, separately, the number of teeth in the gear, cannot be divided by the same number, excluding one. The number of teeth in the sample problem of 35 and 55 is not a hunting ratio because both numbers can be divided by 5. A hunting ratio can be attained with just a minor adjustment by changing the ratio to 34/55, 36/55, or 35/54. The ratio 35/56 is not a hunting ratio because both numbers can be divided by 7. The same principal holds true for the ratio of the number of teeth in a mesh-like action gear cutter to the number of teeth in the piece being machined.

Gear Shafts

Description: A *shaft* is a rotating member that transmits power as opposed to an *axle* which is similar to a shaft but is loaded chiefly in bending and carries rotating parts such as a wheel. Shafts can be made from low carbon, low alloy steel with a tensile strength of 63,000 psi to a tensile strength of 152,000 psi for a higher grade of steel. Shafting known as *turned and ground* can be furnished to very exacting incremental sizes for a minimum of in-plant processing before use.

Rim Thickness: Before the gear shaft can be designed, the gear rim must be sized. The gear rim is the ring of material that lies under and serves to hold and support gear teeth. The gear rim must be of sufficient radial thickness to prevent fatigue cracks from propagating through the rim rather than through the gear teeth. AGMA Standard ANSI/AGMA 2001-D04 states that gear rim radial thickness must be at least 1.2 times tooth whole depth. In Figure 7, the whole depth of the 3 diametral pitch teeth is .75 inch. Multiplying .75 by 1.2 equals .90 inch which is the minimum rim thickness for that size tooth. If the design includes a keyway or spline, rim thickness must be increased an amount sufficient enough to accommodate the keyway or spline itself and any deleterious stress concentration effects that it may have on the rim. Tooth whole depth for the 7 diametral pitch gear teeth in the sample problem equals .321 inch ($2.250/7$). Minimum rim thickness for the sample gears equals .385 inch ($.321 \times 1.2$) assuming there are no keyways. This is a valid assumption since it is common practice to press or shrink fit gears on shafts to the extent that there is no need for a locking device such as a keyway or spline. The pitch diameter of the pinion gear in the sample problem is 5 inches ($35/7$). Five inches minus two times the tooth Dedendum ($2 \cdot 1.25/7$) equals 4.643 inches minus two times the minimum rim thickness ($2 \cdot .385$) equals 3.873 inches which is the maximum diameter that the shaft can be without intruding into minimum rim thickness space.

Figure 7

Gear Rim Thickness

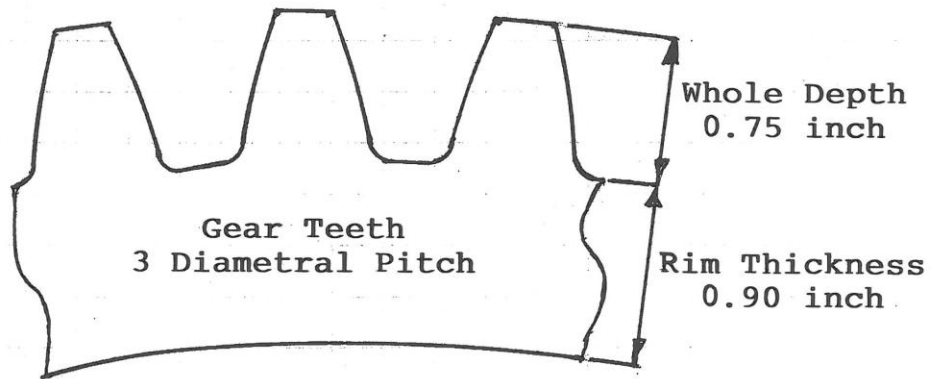

Minimum Rim Thickness
 $1.2 \times \text{Tooth Whole Depth} = 0.90$

Shaft Design: An article courtesy of the American Society of Mechanical Engineers (ASME) Mechanical Engineering magazine Vol.49/No.5, May, 1927 474-476; copyright Mechanical Engineering magazine gives the following formula to calculate gear shaft diameter:

$$D = \{ 16 / \pi p_t [(K_m M)^2 + (K_t T)^2]^{1/2} \}^{1/3}$$

D is the shaft diameter in inches to support the given load. π (pi) is a constant which equals 3.142. p_t is the maximum allowable shaft shear stress in psi which for commercial grade shaft material is 8,000 psi. K_m and K_t are shock and fatigue rating factors explained in the ASME document given above and equal 1.500 and 1.000 respectively for rotating shafts with gradually applied or steady loads. M is the maximum bending moment on the shaft and equals 9103 inch-pounds using a beam formula. T is the transmitted torque and equals 75,000 inch-pounds for 1190 horsepower which is the highest amount of power that the sample gearset can safely deliver. Inserting the above values into the above formula reveals that the minimum shaft diameter equals 3.643 inches. This is less than the 3.873 inches calculated above for minimum rim thickness and therefore assures an acceptable design. The difference of .230 inch (3.873-3.643) can then be added to either the gear rim thickness, the shaft diameter, or proportionately to both, whatever is deemed to be of more benefit to the design.

Rolling Contact Bearings

Background: *Rolling contact bearings* are comprised of *ball bearings* and *roller bearings*. Ball bearings, as the name suggests, utilize balls or spherical shaped rolling elements that are contained between an inner and outer ring. Most roller bearings use either cylindrical or tapered rolling elements. Both are used primarily to support rotating shafts in mechanical equipment. They can be found in everything from personal computers to passenger cars. They are of simple design and can be precision made in mass production quantities. They can support heavy loads over a wide speed range and do it virtually friction free. They come in many different sizes and shapes, are relatively inexpensive, and require little or no maintenance. They have predictable design lives and operating characteristics and are truly a valuable asset to the field of Mechanical Power Transmission.

Description: Rolling contact bearings consist of an inner ring (IR), an outer ring (OR), a complement of rolling elements, and a member to contain the rolling elements as shown on Figures 8,9,&10. The outside diameter of the inner ring (IROD) and the inside diameter of the outer ring (ORID) have a central located track in which the rolling elements revolve in. This track is commonly called the *pathway*. The raised surfaces on each side of the track are called the *shoulders* on ball bearings and *ribs* on roller bearings. The rolling elements are held equally spaced around the annulus of the bearing by the *separator*. The basic dimensions of the bearing are the inside diameter or the bore (B), the outside diameter (OD), and the width (W).

Loading: In most cases, there are two bearings supporting a rotating shaft. The bearing inner ring is a press fit on the shaft to prevent any slippage while the shaft is rotating. The outer ring is a loose fit in the housing for assembly reasons and also to allow slight axial movement to accommodate manufacturing tolerances and differential thermal expansion between the shaft and housing. Forces are imposed on a bearing by the member that is driving the shaft. The force can be separated into a radial load and a thrust load. The sketch at the top of Figure 11 shows radial loads acting perpendicular to the bearing axis of rotation and thrust loads acting parallel to the axis of rotation. In many instances, there are two radial loads acting 90° apart as shown by the second sketch of Figure 11. The Pythagorean Theorem is then used to calculate the resultant radial load on the bearing. The radial load can sometimes be straddle mounted between two bearings as shown on the third sketch of Figure 11. Simple beam calculations will show

Figure 8

Ball Bearing Terminology

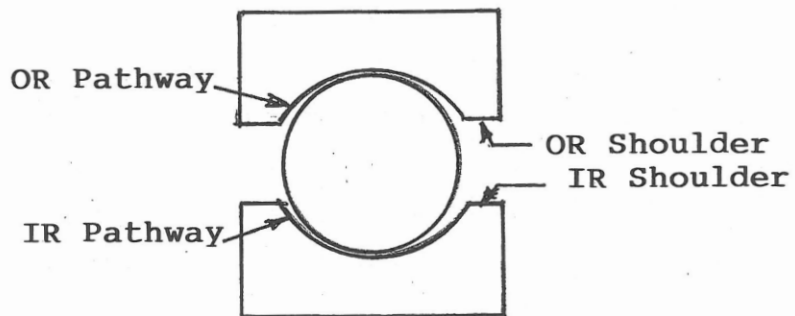
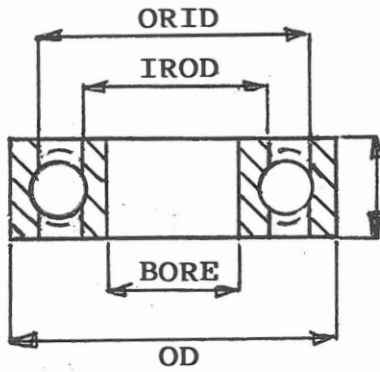
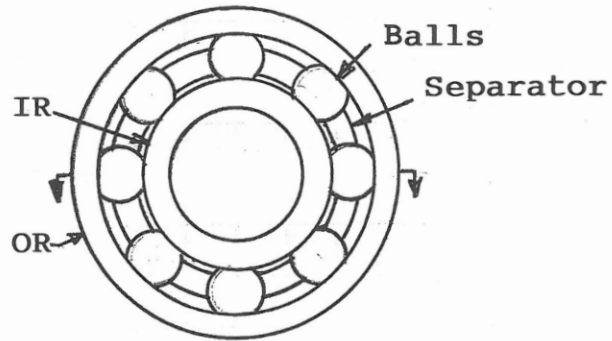

(Exaggerated View)

Figure 9

Cylindrical Roller Bearing

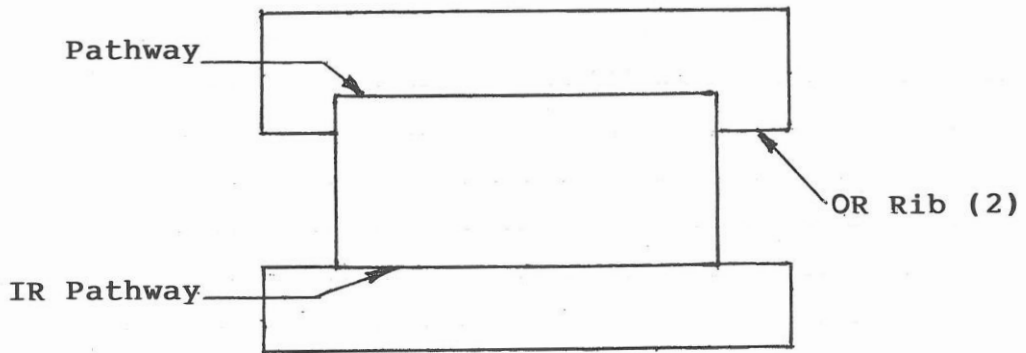
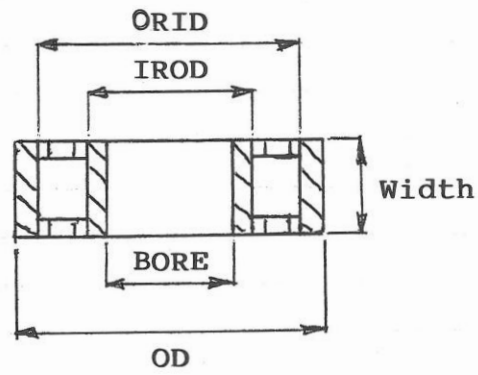
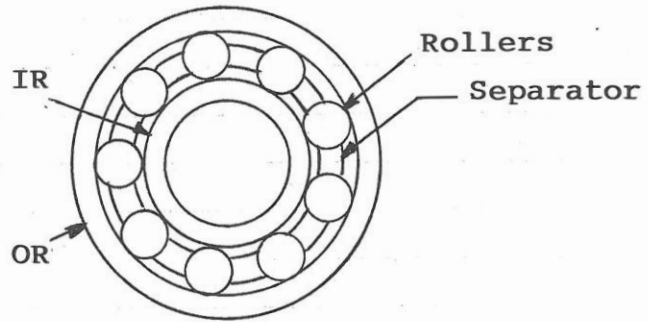

(Enlarged Section)

Figure 10

Tapered Roller Bearing

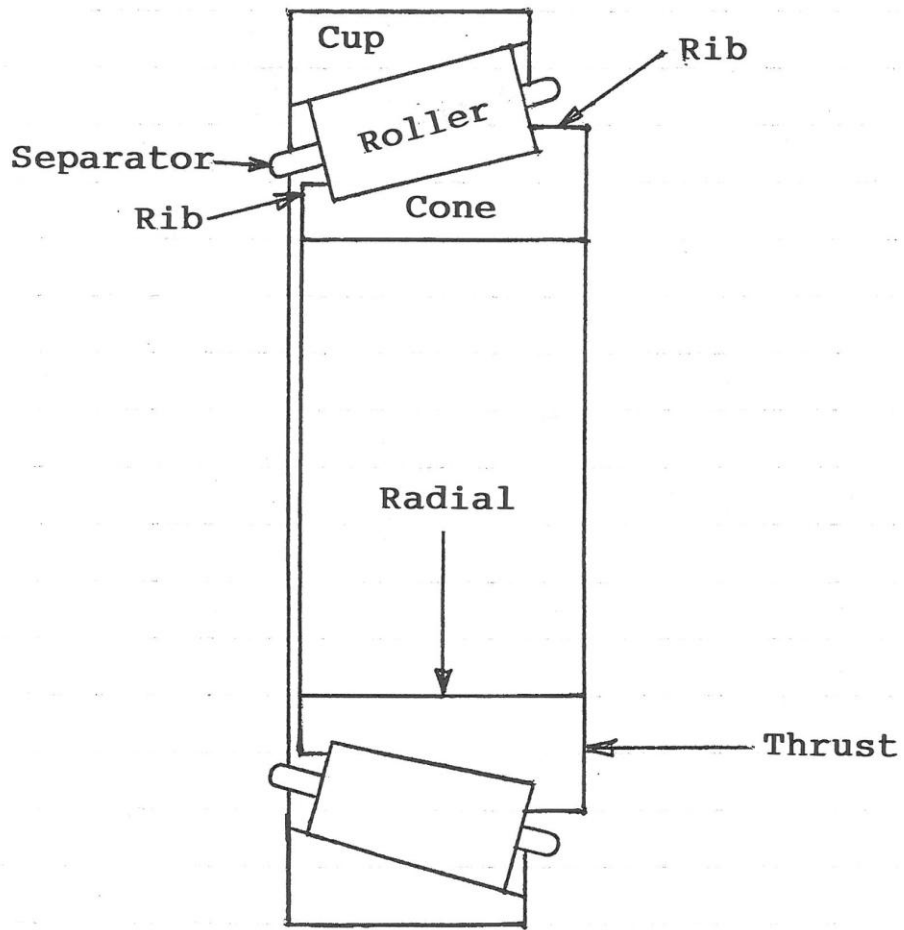
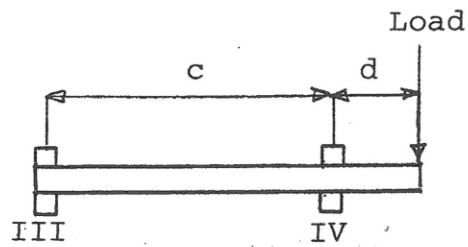
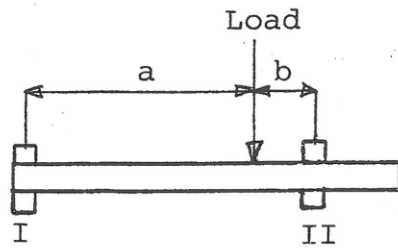
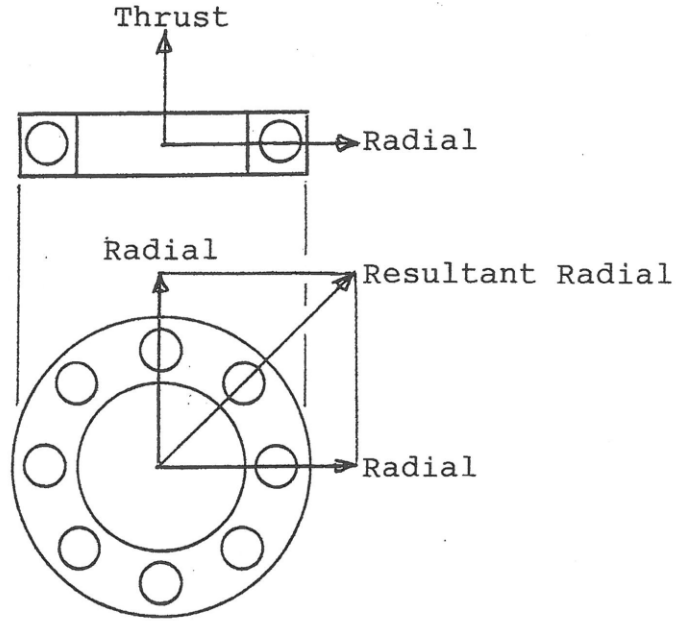

Figure 11

Forces Acting on Bearings



that the bearing located closer to the load supports the greater portion of the load. The fourth sketch of Figure 11 has the load overhanging the two bearings. Beam calculations show that the bearing closer to the overhanging load supports a force that is actually greater than the load itself. Bearing loads, along with speed of rotation, are then inserted into an equation that predicts bearing hours of operating life in an application.

Material: The standard grade steel used for ball bearing rings and rolling elements is high carbon, high chromium, and vacuum degassed AISI/SAE 52100 steel. The steel is heat treated to the Rockwell C60 level throughout. The high carbon content of 1% gives steel excellent response to heat treatment resulting in very high strength after *thru-hardening* to the Rockwell C60 range for both balls and rings. High chromium content of 1.35% further increases response to heat treatment and adds depth to hardness penetration. Vacuum degassing removes impurities making the steel extra clean. Impurities in steel, called inclusions, if occurring in the bearing highly stressed load zone area, can cause premature failure. For extremely critical applications, consumable electrode vacuum degassed steel is available for an even higher degree of cleanliness. The best steel for roller bearing is AISI/SAE 8620 steel. The .55% nickel content in the steel increases strength and toughness. The .50% chromium content increases response to heat treatment. The .20% molybdenum adds greatly to the penetration of hardness and increases toughness. The rings and rollers are heated in a carbon enriched atmosphere significantly raising the carbon content in the steel outer layers (*case*). They are then quenched raising the case to the RC60 hardness level giving roller bearings good load carrying capacity. The inner layer (*core*) is held to a significantly lower hardness level giving roller bearings, which react much stiffer to load than ball bearings, good impact resistance.

Types: The three most commonly used types of ball bearings are the radial bearing, the angular contact bearing, and the double row bearing as shown on Figure 12. The radial ball bearing is designed to accommodate primarily radial loads although some will support bidirectional thrust loads up to 35% of the radial load before operational life becomes progressively shorter. The assembled radial bearing is inseparable and may be equipped with seals, shields, and/or snap rings for mounting purposes (discussed later). For radial ball bearings under radial load only, the line of contact between balls and rings is perpendicular to the bearing axis of rotation. For angular contact ball bearings, this line is at an angle to the perpendicular and is

Figure 12

Ball Bearing Types



Radial Ball Bearing

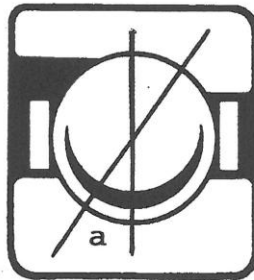

Angular Contact Ball Bearing

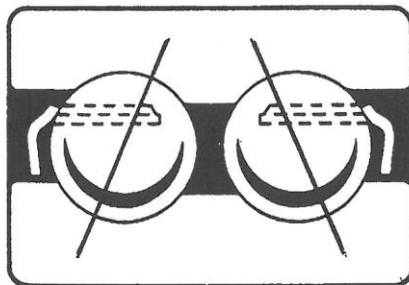

Double Row Ball Bearing

called the contact angle as indicated by the letter “a” on the second sketch of Figure 12. In angular contact ball bearing design, one of the pathway shoulders is removed to allow assembly of a maximum complement of balls for increased load carrying capacity. Angular contact ball bearings support both radial and high one-direction thrust loading.

The upper sketch of Figure 13 has two angular contact ball bearings mounted *back-to-back*. This type of mounting has good radial and axial rigidity and provides resistance to shaft overturning moments and angular deflection.

The second sketch of Figure 13 shows two angular contact ball bearings mounted *face-to-face*. This type of mounting has the same radial and axial rigidity as the back-to-back mounting, but offers less resistance to overturning moments and more compliance to misalignment and bending of the shaft.

The third sketch on Figure 13 portrays two angular contact ball bearings mounted in *tandem* (face-to-back). This mounting arrangement provides resistance to high one-direction thrust loading. The total thrust capacity of the pair is approximately 1.62 times the thrust capacity of one of the bearings. For even higher thrust capacity, three or more angular contact ball bearings can be mounted in tandem.

Double row ball bearings support heavy radial loads, thrust loads from either direction, or combined radial and thrust loads. They are used in positions where radial loads exceed the capacity of a single row ball bearing with a comparable bore and OD. Double row bearings are designed with the inside and outside diameters the same as single row bearings but are narrower than two adjacent single row bearings. The top sketch of Figure 14 shows a double row ball bearing with contact lines “internally divergent”. This is similar to two angular contact ball bearings mounted back-to-back. This double row configuration can be designed internally preloaded giving it rigidity high enough to resist axial, radial, and overturning moments making it ideal for single bearing mounting such as gears, wheels, and pulleys. The lower sketch depicts a double row ball bearing with the contact lines “internally convergent”. This type has the same resistance to radial and axial loading as their single row counterparts but lack the resistance to angular loading.

Figure 13

Angular Contact Bearing Pairs

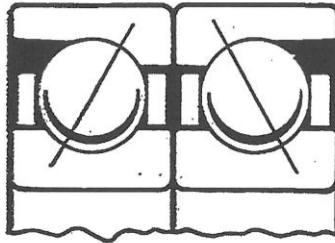

Back-to-Back Mounting

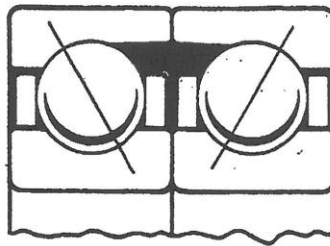

Face-to-Face Mounting

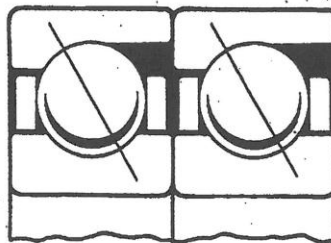

Tandem Mounting

Figure 14

Double Row Ball Bearing

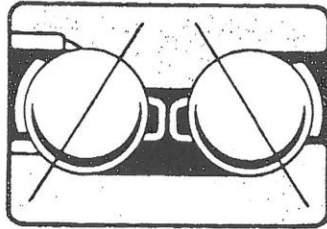

Internally Divergent

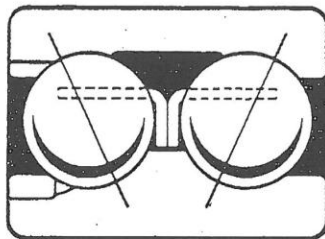

Internally Convergent

The two most common types of roller bearings, as mentioned, are the cylindrical roller bearing and the tapered roller bearing. Cylindrical roller bearings can support heavy radial loads but are limited in thrust loads up to 10% of the radial load. Cylindrical roller bearings can be manufactured in a number of different configurations as shown and explained on Figure 15. They range from inner and outer rings without shoulders to designs with one or two shoulders. Shown are cylindrical roller bearings that can have inner rings removed and run directly on hardened shafts and others with outer rings removed and run directly inside housing bores. Tapered roller bearings can support both radial and thrust loads. Tapered roller bearings can be manufactured in either single or double row as shown on Figure 16.

Sizes: Most rolling contact bearings fall into three series of categories based on their cross sectional area with the larger sizes able to support heavier loads. The three most commonly used series are: extra-light, light, and medium. (See Figures 17.) Bearing envelope dimensions are generally dimensioned in millimeters, although inch sizes are also available. A common range of sizes offered by industry is from a 3 mm bore, 16 mm OD, 130 lb radial capacity ball bearing to a 240 mm bore, 440 mm OD, 120,000 lb capacity cylindrical roller bearing. Bearing envelope and bearing mounting surfaces are established by an industry wide standard so that product from various manufacturers can be used interchangeably. As previously mentioned, it is standard practice to have the bearing rotating ring be a press fit on its mounting surface and the non-rotating ring be a loose fit on its mounting surface. The Annular Bearing Engineers Committee (ABEC) has established five industry-wide classifications for inner and outer ring bearing fits. They are referred to as ABEC 1, 3, 5, 7 & 9. Higher numbered classifications refer to tighter tolerances on inner and outer ring fits. For instance, the ABEC 1 tolerance for the fit of a rotating inner ring press fit on its shaft is .0009 inch tight to .0001 inch loose while the non-rotating outer ring fit is .0001 inch tight to .0010 inch loose. The ABEC 9 tolerances for the same conditions are .0001 inch tight to .0001 inch loose for the inner ring and .0000 inch to .0003 inch loose for the outer ring. ABEC 1 is the standard grade of mounting fit precision and is generally adequate for most ball bearing applications. ABEC 3 & 5 grades are specified where narrower tolerances are required to give desired refinements in mounting and running accuracy. ABEC 7 & 9 are available for applications where extreme accuracy and true running are necessary. These super precision grades are used in aircraft, machine tool, and fine instrument service.

Figure 15

Cylindrical Roller Bearing
Design Configurations

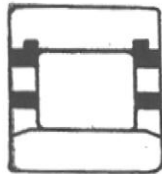

Low cost two-part bearing. Inner ring can be removed and bearing run directly on shaft.

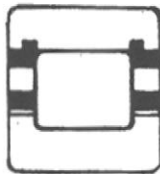

Non-separable bearing design for ease of shipping, handling, and assembly.

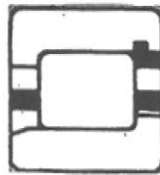

Ribs on opposite sides of bearing allow for supporting one-directional thrust.

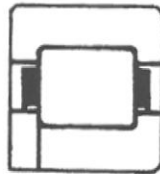

Inner ring plate allows two-direction thrust. Has formed bar and side ring high speed separator.

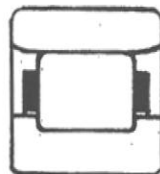

Outer ring can be removed and bearing run directly in housing. Has high speed separator.

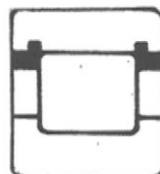

No separator allows full complement of rollers and maximum load capacity. Speed limited.

Figure 16

Tapered Roller Bearing Types

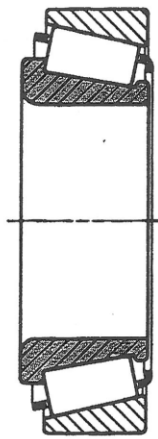

Single Row

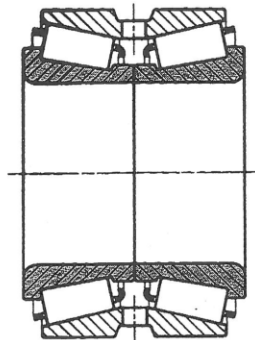

Double Row

Figure 17

Bearing Series

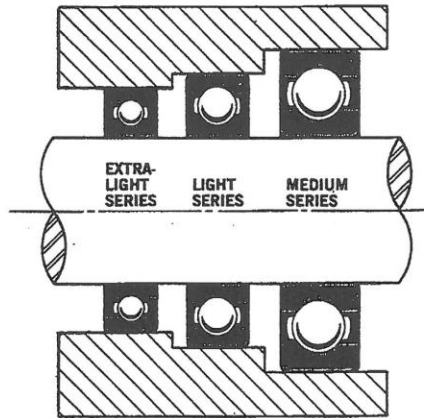

RELATIVE PROPORTIONS OF BEARINGS WITH SAME BORE DIMENSION.

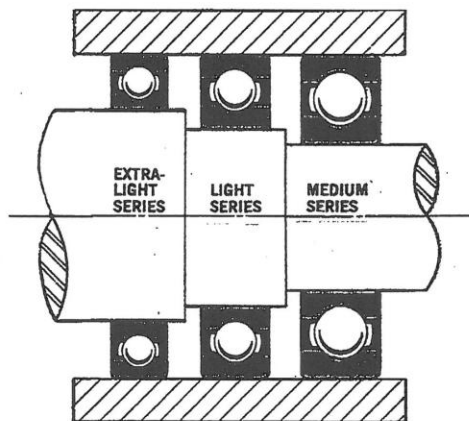

RELATIVE PROPORTIONS OF BEARINGS WITH SAME OUTSIDE DIAMETER.

Life: B10 life is a calculated number of hours that 90% of bearings are expected to achieve in their lifetime under a specified load and speed without failure. Rolling contact bearing B10 life can be expressed as follows:

$$L_{10}=3000(C/P)^{10/3}(500/S)$$

L_{10} is the bearing B10 life in hours. C is the capacity of the bearing and is found in industry catalogs and is the number of pounds that the bearing can support for 3000 hours of operation at 500 revolutions per minute (rpm). P is the equivalent radial load in pounds which takes into account both radial and thrust loads and is also found in industry catalogs. S is the application speed in rpm. It can be seen that because of the 10/3 power, bearing life is especially dependent on bearing load and not as dependent on speed which has no exponent.

Sample Problem: A shaft supported by two single row radial ball bearings has a gear at the center driving a tool at 2000 rpm. One bearing supports a 100 lb radial load while the other supports a 100 lb radial load and a 100 lb thrust load. The capacity of each bearing is 570 lb. The calculated life of each bearing using the previously mentioned equation is as follows:

$$L_{10}=3000(570/100)^{10/3}(500/2000) = 247,966 \text{ hr (R=100\#, T=000\#)}$$

$$L_{10}=3000(570/172)^{10/3}(500/2000) = 40,680 \text{ hr (R=100\#, T=100\#)}$$

The B10 life of the first bearing is very high. A smaller bearing could be used; however, using the same bearing at each end of the shaft can sometimes be justified for reasons of standardization and also to simplify shaft and housing design and manufacture. The B10 life of the second bearing represents 4.8 years of continuous operation.

Suppose that the machine tool in the previous example experienced severe vibration and corrective action had to be taken. One approach in solving the problem would be to preload the bearings. Preloading is accomplished by applying a thrust load to one of the bearings and having it reacted by the other on the same shaft. This has the effect of stiffening the bearings and making the shaft less prone to vibration. Assume that, after preloading, the thrust increases from 0 to 100 lb on the first bearing and from 100 to 200 lb on the second. The radial load remains the same. Using the existing radial bearings, the calculated lives are as follows:

$$L_{10}=3000(570/172)^{10/3}(500/2000) = 40,480 \text{ hr (R=100\#, T=100\#)}$$

$$L_{10}=3000(570/284)^{10/3}(500/2000) = 7,647 \text{ hr (R=100\#, T=200\#)}$$

It can be seen that the lives of the two bearings have decreased significantly from the 247,966 and 40,680 numbers obtained before preloading. Now let us repeat the above calculations using angular contact ball bearings with the same basic overall dimensions:

$$L_{10}=3000(475/103)^{10/3}(500/2000) = 122,376 \text{ hr (R=100\#, T=200\#)}$$

$$L_{10}=3000(475/169)^{10/3}(500/2000) = 23,493 \text{ hr (R=100\#, T=200\#)}$$

The use of angular contact bearings, as seen from the above calculations, has increased predicted life by more than threefold. This exercise has shown how angular contact ball bearings can improve design life when higher thrust loads are present. Replacing ball bearings with tapered roller bearings will show even significantly higher bearing lives in both positions.

Lubrication: Highly refined mineral oils are among the best lubricants for rolling contact bearings. Synthetics have been developed that are good but some do not form lubricating films as well as mineral oils. Commonly used means for delivering oil to bearings include jet, bath, mist, and wick feed. The best overall system is oil jet combined with a recirculating system. This method directs a pressurized stream of oil into the bearing load zone. The oil is then drained back to a sump where it is filtered, cooled, and returned. This system is good for a variety of bearing loads and speeds. The oil bath method is commonly used in gear boxes. The housing is filled with oil until it just touches the lowest rotating component distributing the oil throughout the gearbox internals. Mist systems use pressurized air to atomize oil. The mixture is then sprayed onto the bearing where it lubricates and cools. Air-oil mist systems are used primarily for high speed applications. Wick systems use an absorbent material to store oil and slowly deliver it to a bearing in a controlled manner. Wick systems are used in electric motors. A simple method of lubricating bearings is by using grease. A carefully measured quantity of grease is evenly distributed throughout the bearing where it is contained by seals or shields. This configuration can run for the life of the bearing. Grease consistency is important. Grease too soft will cause excessive churning losses in a bearing while grease too firm will not lubricate properly. Following is a list of important greases:

- Mineral oil grease for general purpose operation from -30°F to +300°F
- Ester based grease for operation from -100°F to +350°F
- Silicone based grease for operation from -100°F to +450°F but lacks good load carrying ability

Closures: Ball bearing closures are sealing devices that are installed on one or both sides of the bearing to contain grease lubricant, to protect against moisture or foreign substance entry, or to control the flow of lubricant into the bearing when exposed to an oil sump. Grease lubrication and double seals can offer maintenance free performance for the life of a ball bearing although they do limit the speed of operation somewhat.

The top sketch of Figure 18 is of a ball bearing with a rubber lip seal. Lip seals can be installed on both sides of a standard width ball bearing without going outside the bearing envelope and offer a lifetime of operation. This offers a distinct advantage to the designer in packaging mechanical systems in not having to provide a means to lubricate the bearing or not having to provide extra space to accommodate an extra wide sealed bearing.

The second sketch on Figure 18 is a triple lip seal with an outer steel shell to protect against hard particle intrusion. This seal is called *land riding* because the three lips ride on the inner ring outer diameter rather than on a notch such as the single lip seal of above. Besides having three lips for triple sealing, grease can be packed between the lips to further impede contaminant and moisture entry and to lubricate the lips. This concept is the ultimate in lip seal design for heavy duty applications although the drag of the seals does limit the speed of operation somewhat. It is commonly used on farm equipment, construction equipment, and automotive engine coolant pumps.

The bottom closure on Figure 18 is a one-piece all metal design called a shield. It is crimped permanently into a groove in the bearing outer ring. It does not contact the inner ring so it does not limit bearing speed. It is used to contain grease or control the amount of oil ingested into the bearing when exposed to an oil sump. Excessive oil in a bearing can cause high running torque and subsequent failure. Generally seals are not incorporated on roller bearings. If needed, they are mounted in the bearing housing.

Figure 18

Ball Bearing Closures

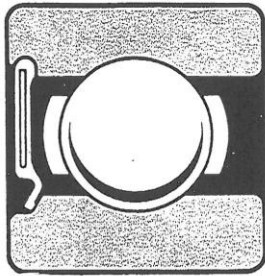

Rubber Lip Seal

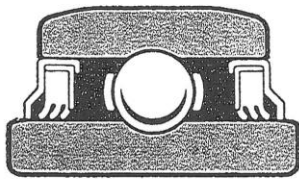

Triple Lip Seal With Guard

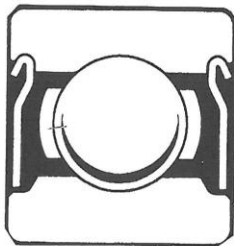

Shields

Application

Bearings: Figure 19 has a flexible shaft handpiece and drive unit utilizing single row radial ball bearings. The handpiece must be small enough to fit inside a clasped hand and support loads from a variety of different tools that are attached at the left end. The handpiece right ball bearing is clamped both on the shaft and in the housing to locate the shaft and support thrust loads. The smaller bearing on the left is free to float in the housing and is used only for radial support. The clamped spacer between the two bearings adds rigidity to the relatively small shaft. The drive unit has single row ball bearings supporting both shafts. Three of the bearings have a seal at the exposed end to retain lubricant and protect against contaminant entry.

A machine tool workpiece-centering support spindle is shown on Figure 20. A double row ball bearing with contact angle lines internally diverging supports the front end of the spindle and two angular contact ball bearing mounted in tandem support the rear. The double row front bearing is manufactured preloaded and supports radial and bending loads while all the thrust load is supported by the two angular contact bearings in the rear. The inner rings are clamped tight while the outer rings are free to move against the compression member supporting the rear bearing.

Gears: Figure 21 has the output shaft of a multi-speed transmission. The compound gear is moved axially on the splined output shaft by the shifter lever at the bottom to separately engage one of three gears at the top. The output shaft is supported by one double row and two single row ball bearings. The two single row bearings, being of different series, have the same OD which allows thru-boring the housing for improved bearing alignment. The different bore dimensions of the two single row bearings allows for easy mounting on the stepped shaft. The right hand bearing is clamped while the other two bearings are allowed to float in the housing to accommodate shaft thermal expansion and accumulated machining tolerances.

A spur gearset supported by cylindrical roller bearings is shown on Figure 22. The roller bearings with double ribbed outer ring and single ribbed inner ring are designed to provide good bearing axial positioning and excellent radial load support. Bearing inner and outer rings can both be assembled with press fits on their respective mounting surfaces easing assembly. The right hand side of the drawing shows an alternate method of bearing

Figure 19

Radial Ball Bearing Application

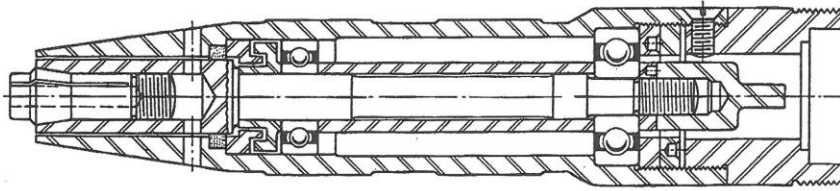

Flexible Shaft Handpiece

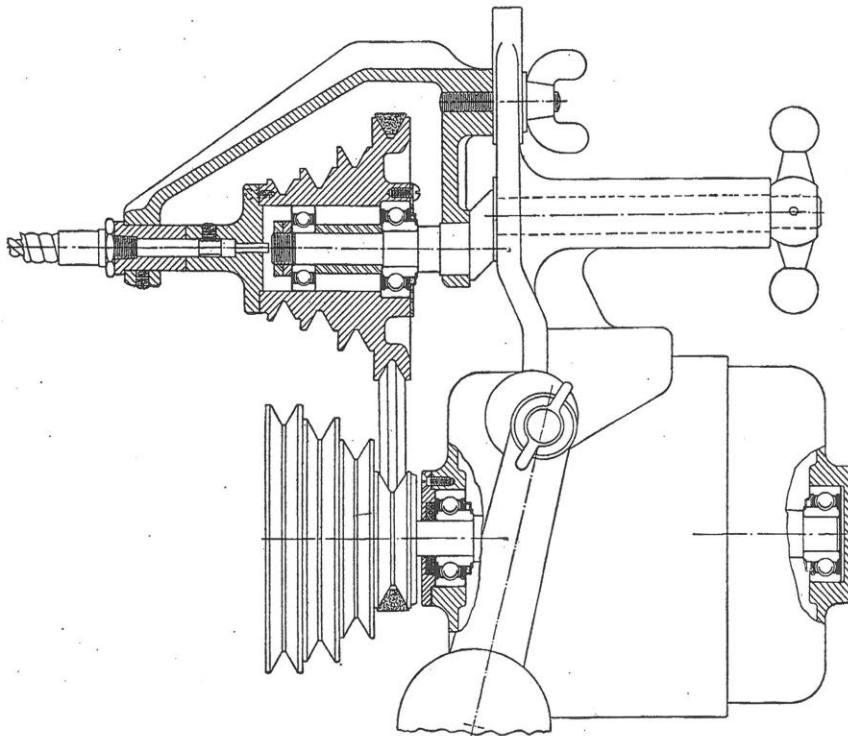

Flexible Shaft Drive Unit

Figure 20

Machine Tool Workpiece Center Support

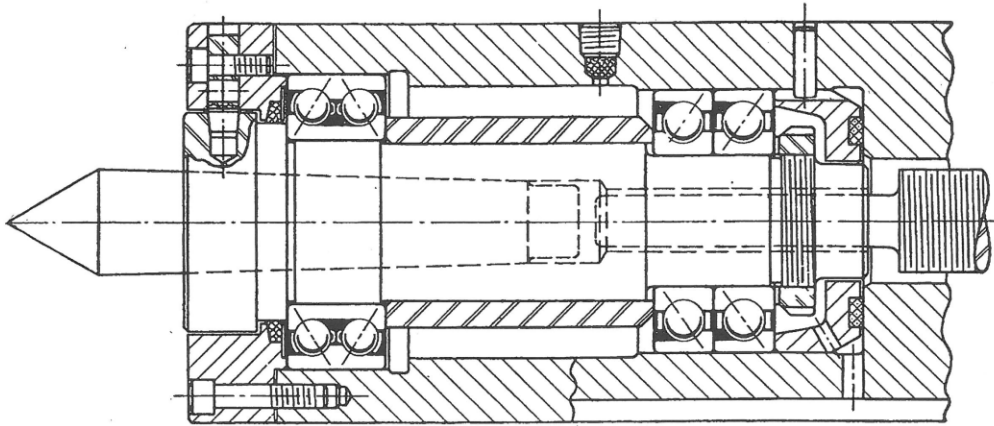

Double Row and Angular Contact Ball Bearings

Figure 21

Multi-Speed Transmission Output Shaft

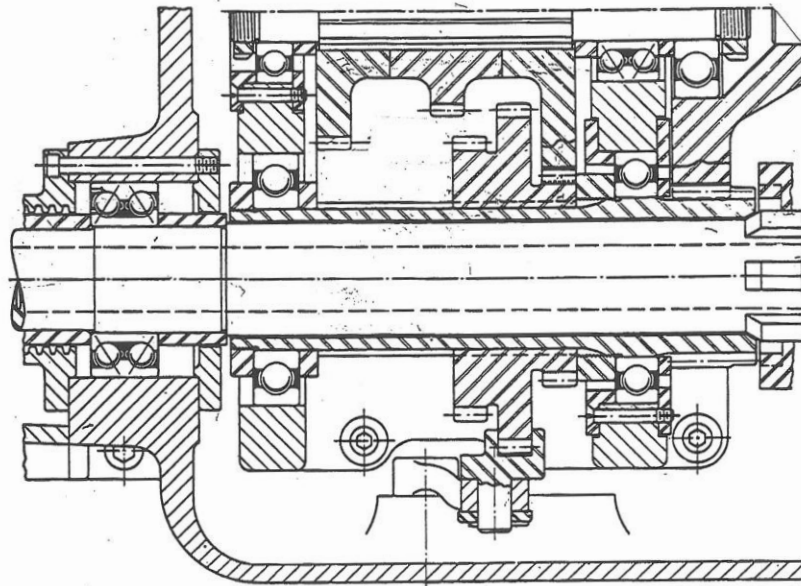

Double Row and Single Row Ball Bearings

Figure 22

Spur Gearset With Roller Bearings

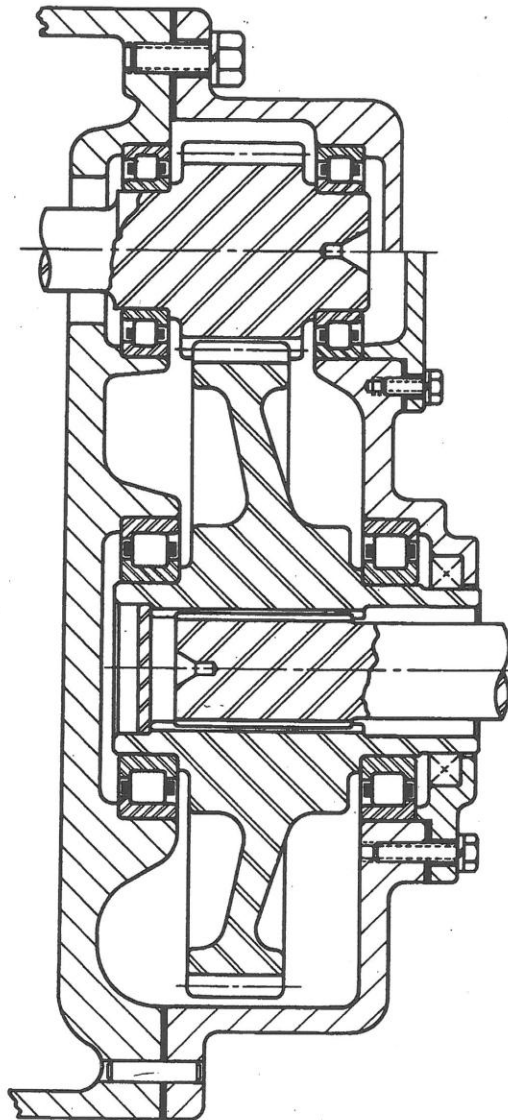

Optional Bearing Mounting Shown on Right

mounting below the centerline using end caps. This method allows thru-boring the housing for better bearing and gear alignment. It also allows replacement of the pinion gear without separating the main housing.

Figure 23 has the center section of an automotive drive axle. Engine power is delivered to the bevel pinion gear shaft on the right to the ring gear. The ring gear delivers power through the two output shafts to the vehicle wheels. The center differential unit allows power to be delivered to both wheels even though one may be rotating faster than the other such as when rounding a corner. The input gearshaft and the output shafts are both supported by tapered roller bearings. The pinion gearshaft is preloaded by tightening the nut until the desired preload is reached. The output shaft tapered roller bearings are preloaded using shims. The center differential unit incorporates two sets of tapered roller bearings that rotate on sleeve bearings.

A right angle commercially available gearbox is shown on Figure 24. It features spiral bevel gears with tapered roller bearings and dual output shafts. The cast iron housing is thru-bored for excellent gear and bearing alignment. Double lip seals ride on hardened and plunge ground shafts for leak proof operation. (Thru-feed grinding can generate a lead on the shaft OD which sometimes acts to pump lubricant out the seal lip.)

Figure 25 has a single input shaft, single output shaft double reduction gearbox. It uses helical gears for improved load carrying capacity and quietness of operation.

Figure 23

Automotive Drive Axle

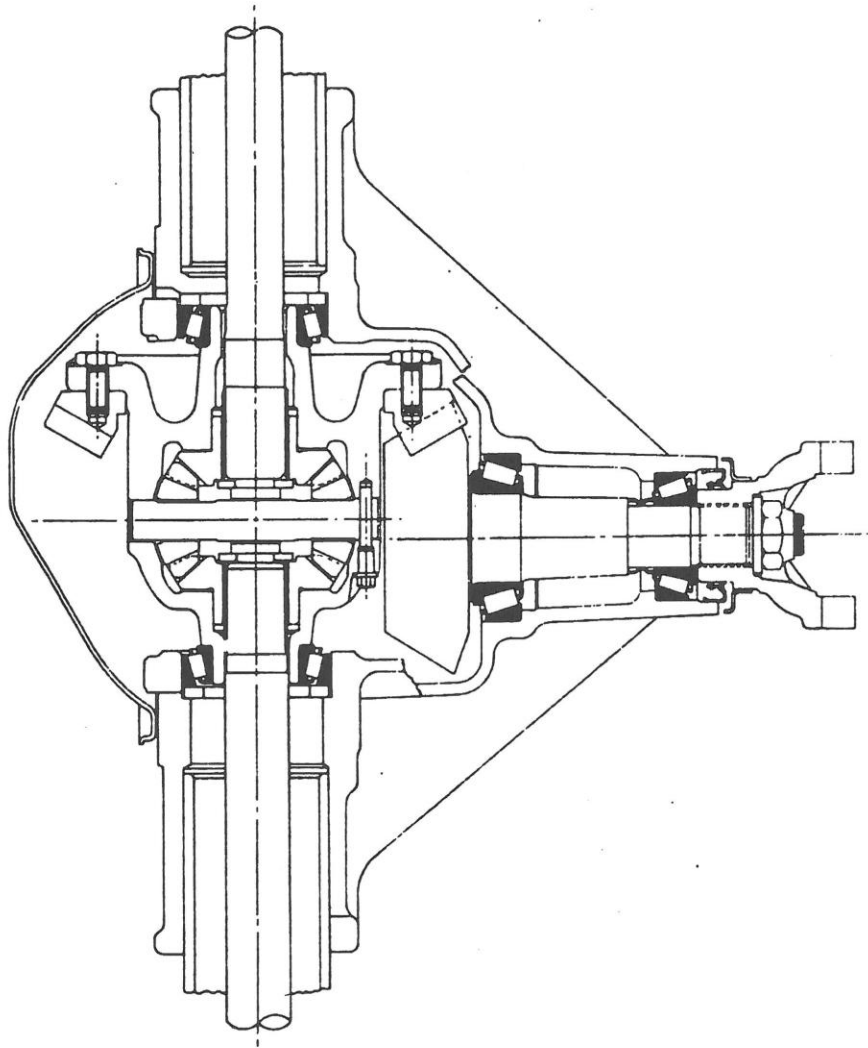

Axle Center Section

Figure 24

Commercial Gearbox

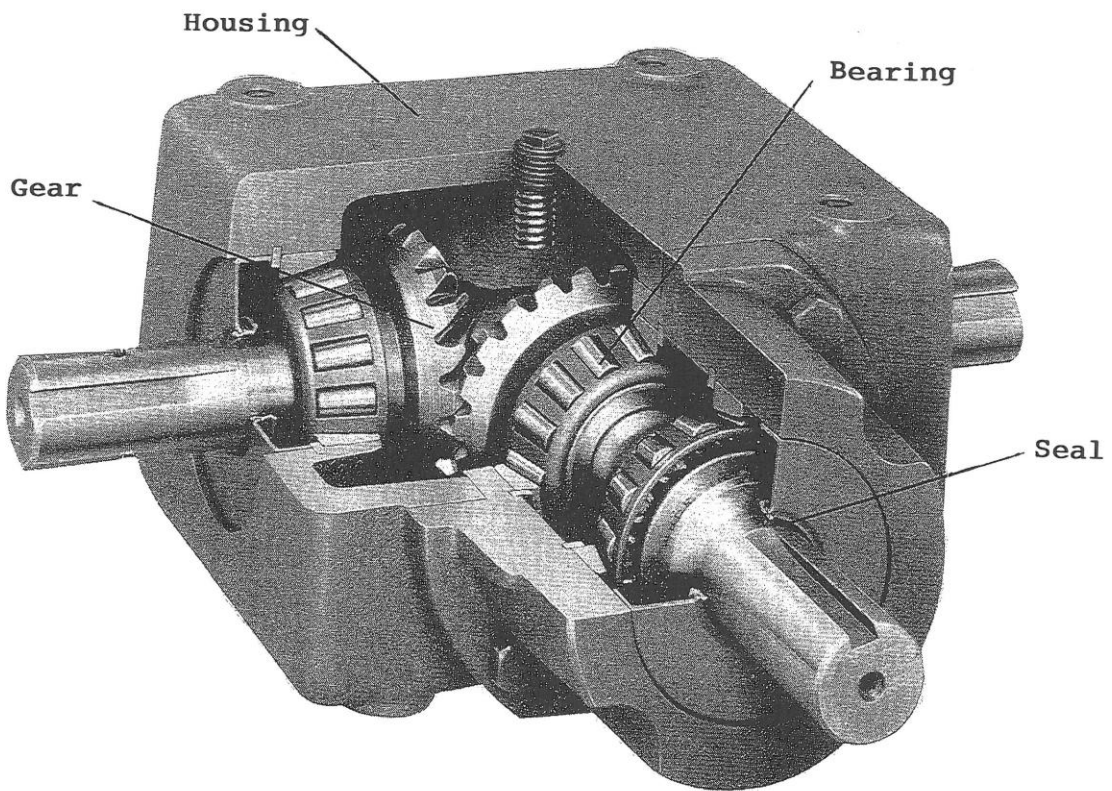

Image courtesy of Emerson Power Transmission

Figure 25

Double Reduction Gearbox

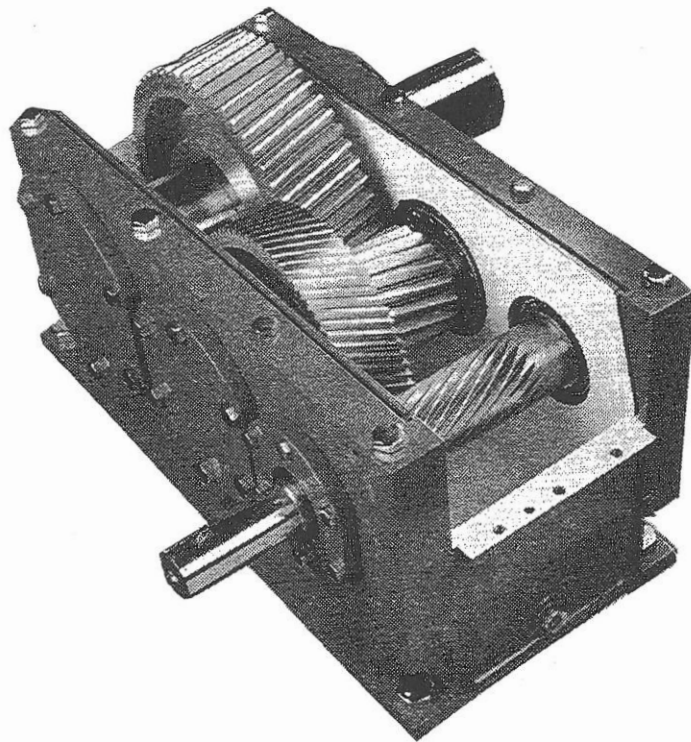

Image courtesy of Emerson Power Transmission