

# Functions of a Pump

- ❖ Transfer fluid between two points.
- ❖ Produce required flow rate.
- ❖ Produce required pressure.

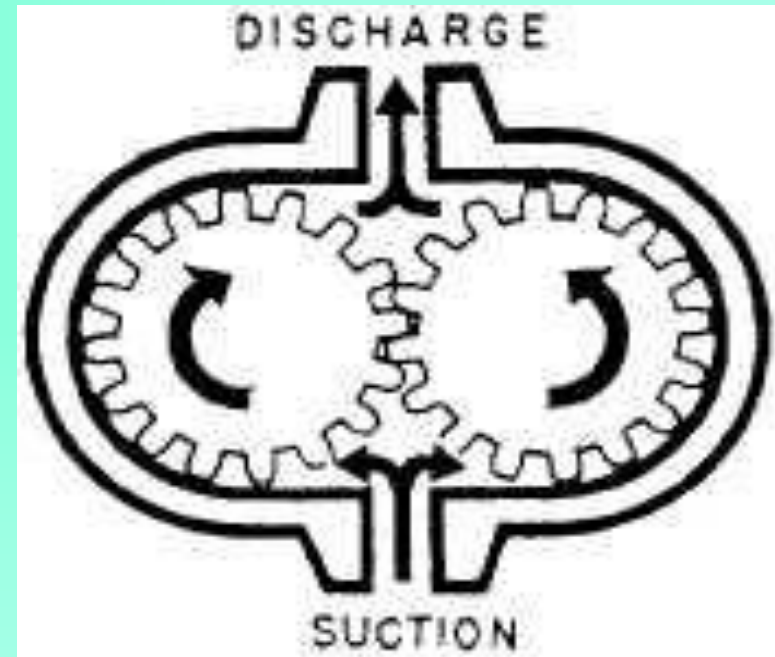

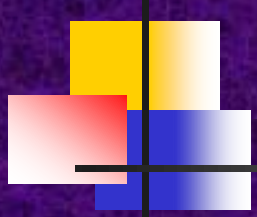

PUMPS- Are used to move liquids , known technically as non-compressible fluids, around or through a pumping system.



# Pump - Facts

---

- Pump changes both velocity and pressure of the fluid.
- Pump only adds to the system energy.



# Pump - Facts

---

- Power supplied to the pump is to transfer fluid at specified flow rate and pressure by overcoming resistance in the pump and the system.
- A pump does not create pressure, it only provides flow. Pressure is just an indication of the amount of resistance to the flow.

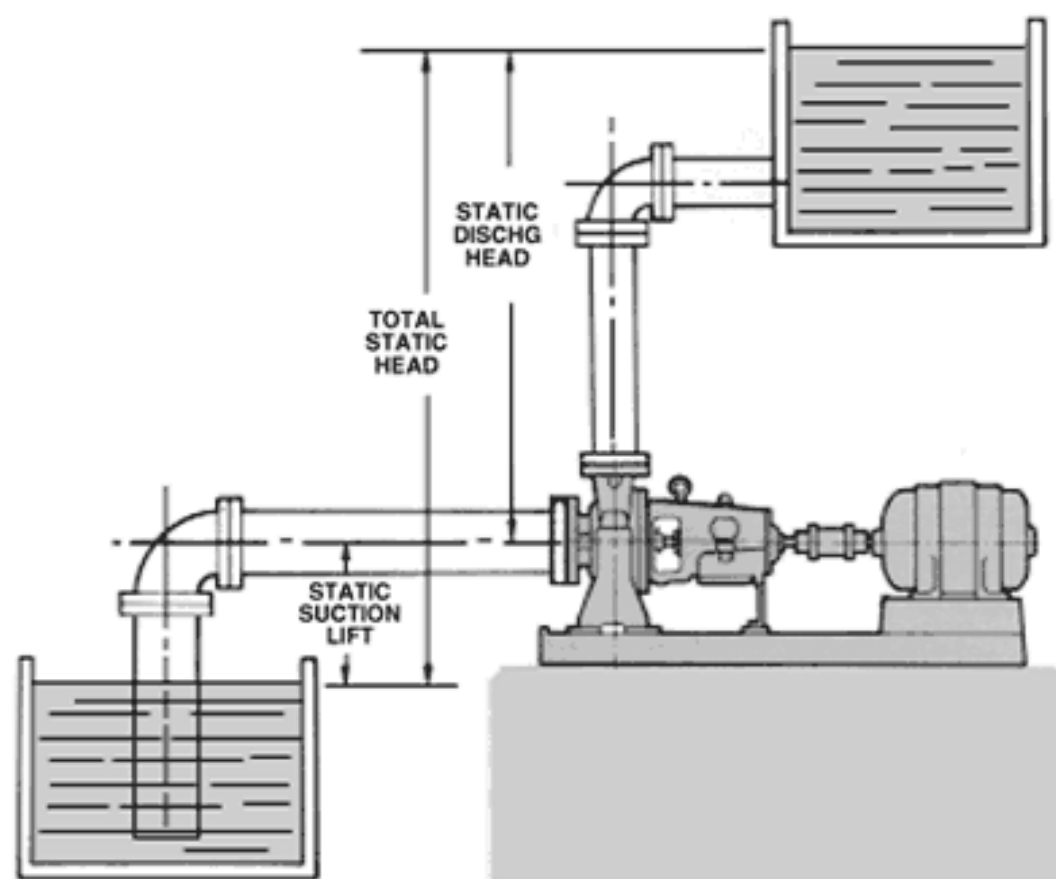
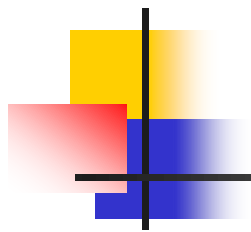

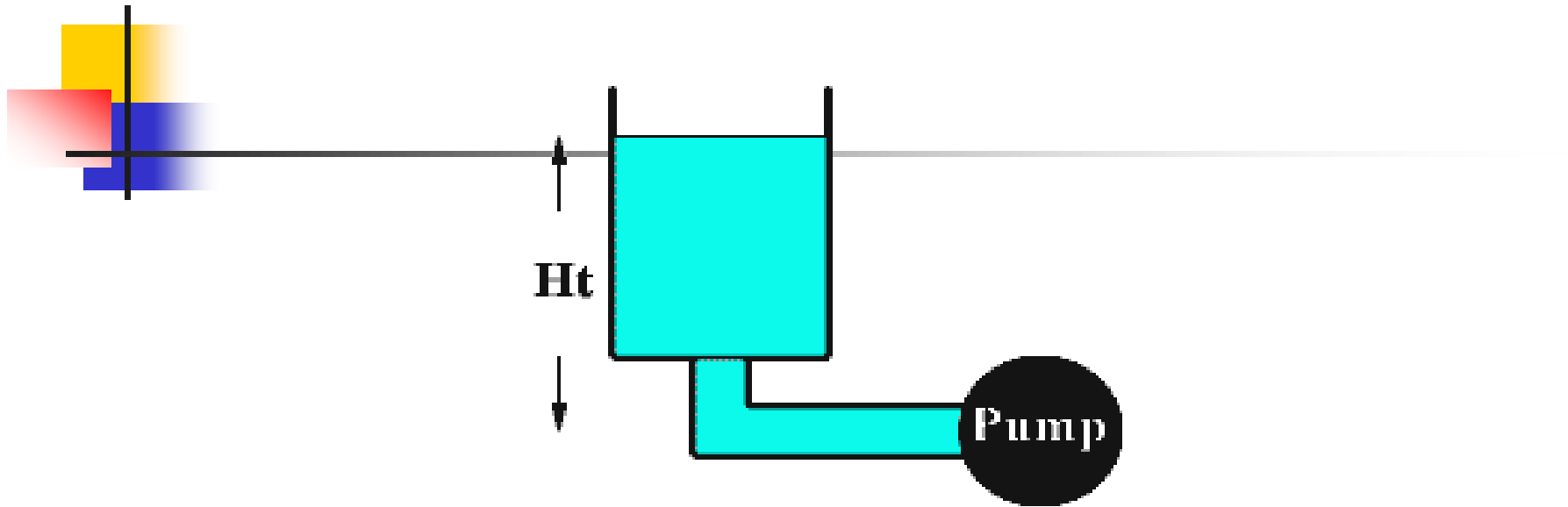

**A Suction Head exists when the liquid is taken from an open to atmosphere tank where the liquid level is above the centerline of the pump suction, commonly known as a Flooded Suction.**

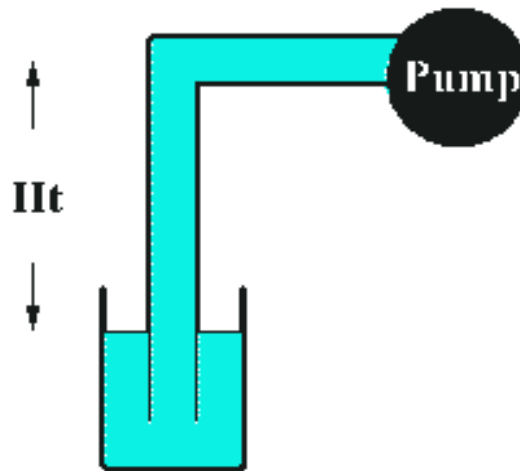

**A Suction Lift exists when the liquid is taken from an open to atmosphere tank where the liquid level is below the centerline of the pump suction**



# Pumps and Viscosity of Fluid Handled.

---

- ❖ Viscosity of the fluid pumped must be within the range specified in the pump design.
- ❖ Reciprocating Displacement pumps can handle any required viscosity.
- ❖ Rotary Positive Displacement Pumps ( Common- Gear and Screw ) are used for intermediate range of viscosities.
- ❖ Centrifugal Pumps are used for Medium to Low range of viscosities.
- ❖ Onboard ships, permission should be obtained before any fluids are moved, which might affect the stability of the ship.



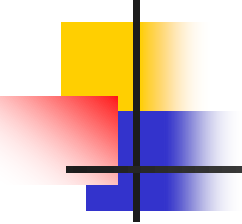

---

**The performance of centrifugal pumps is affected when pumping viscous liquids. A dramatic increase in Brake Horsepower and a reduction of Flow and Head occurs.**

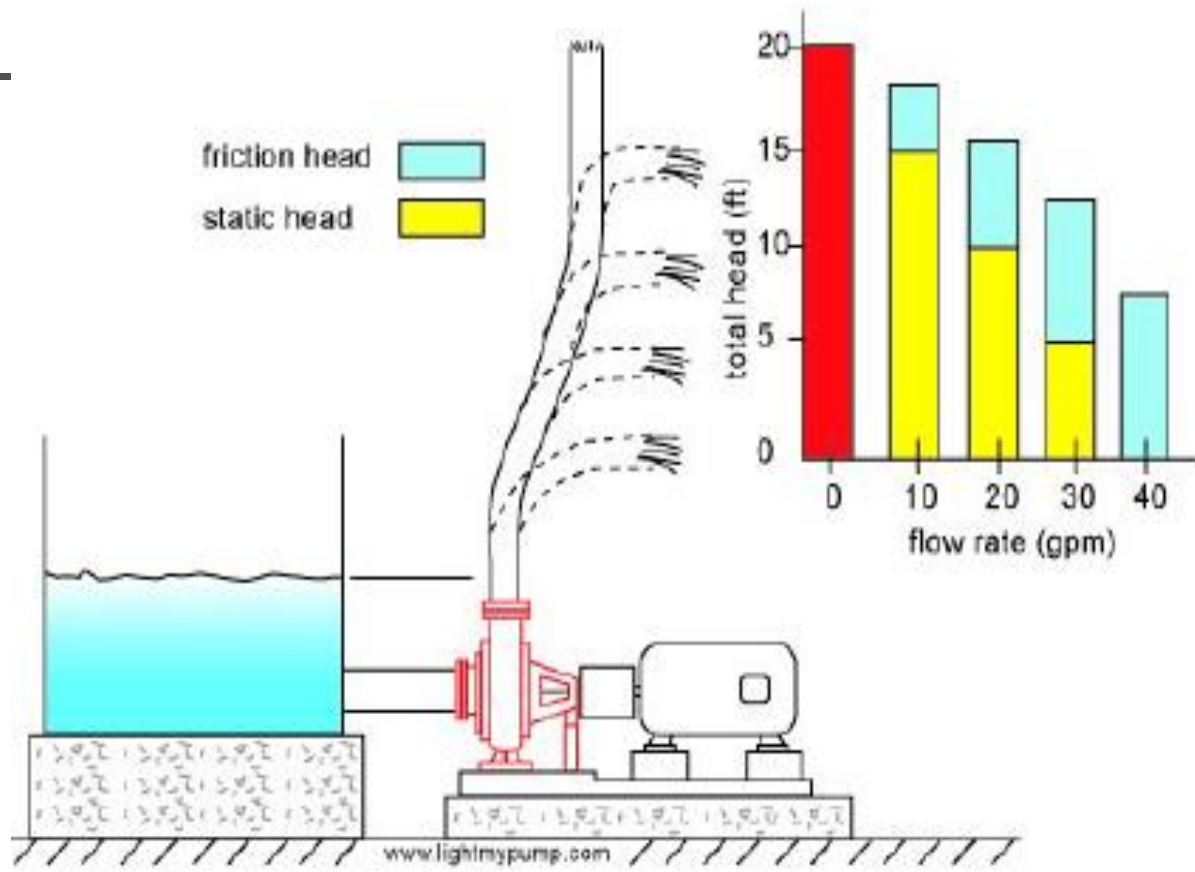
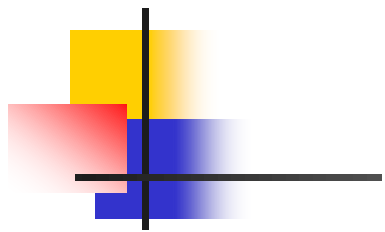

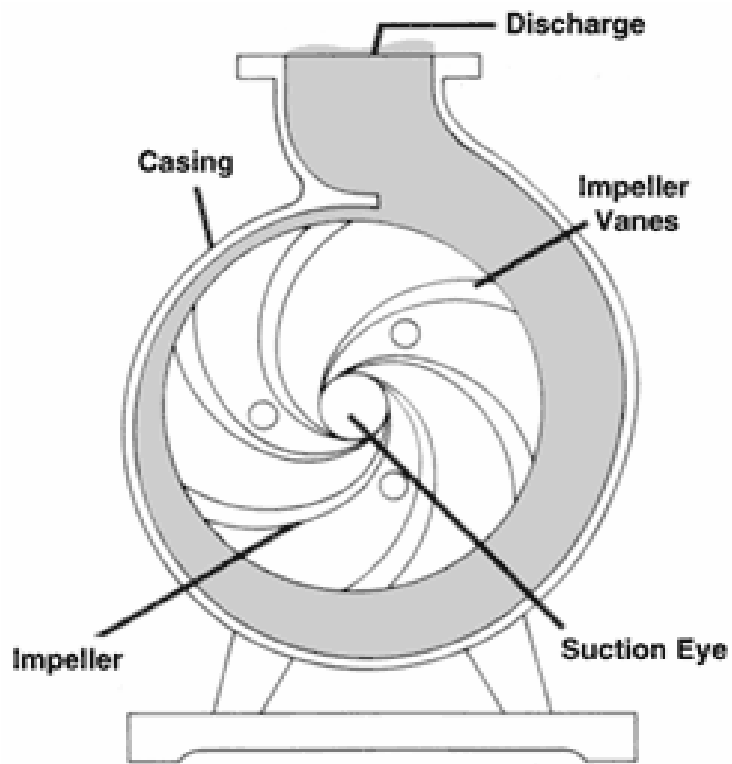
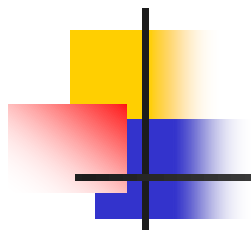

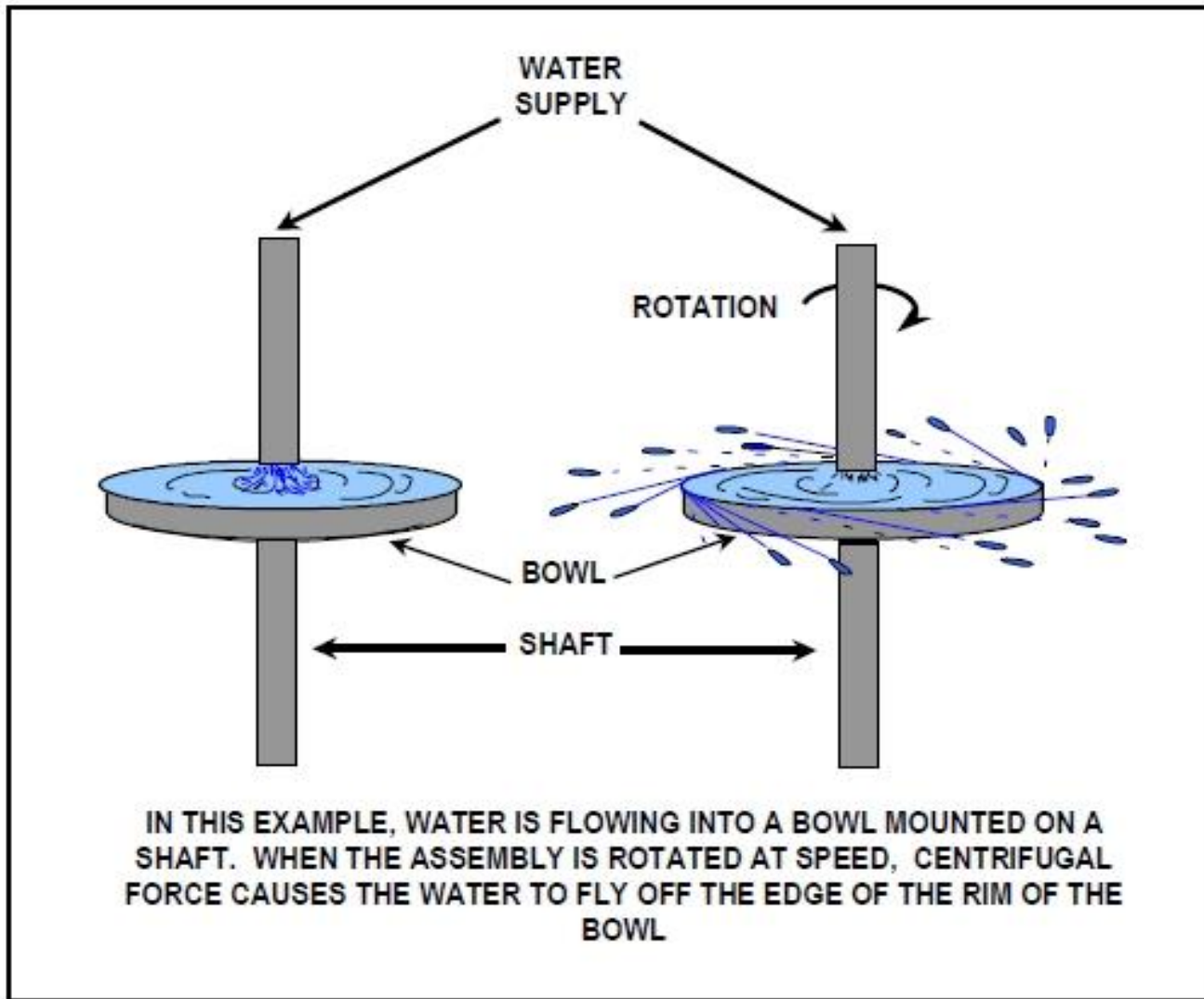

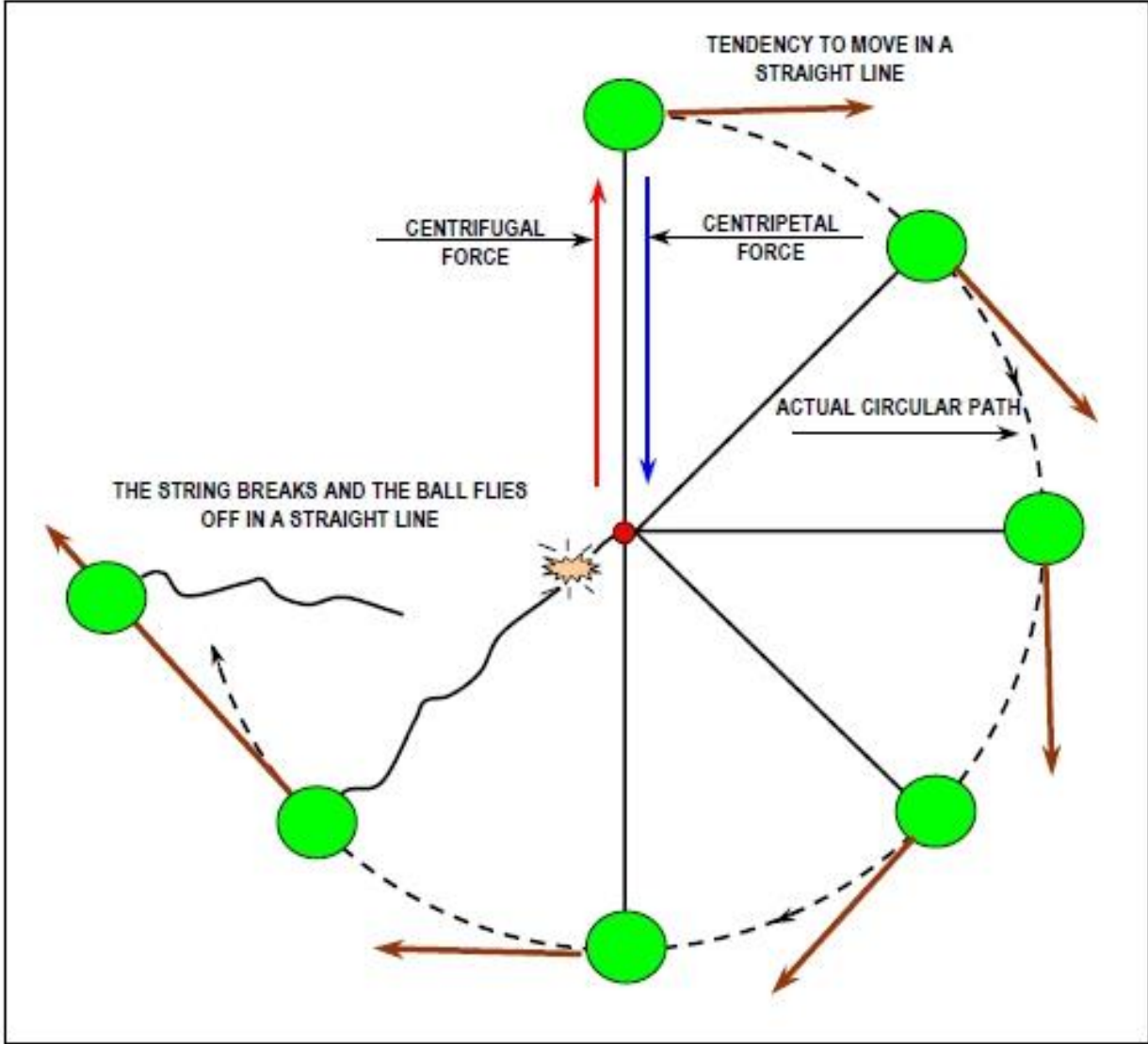
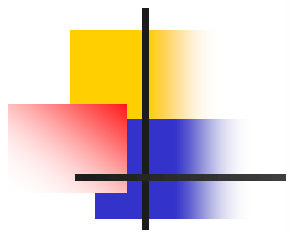

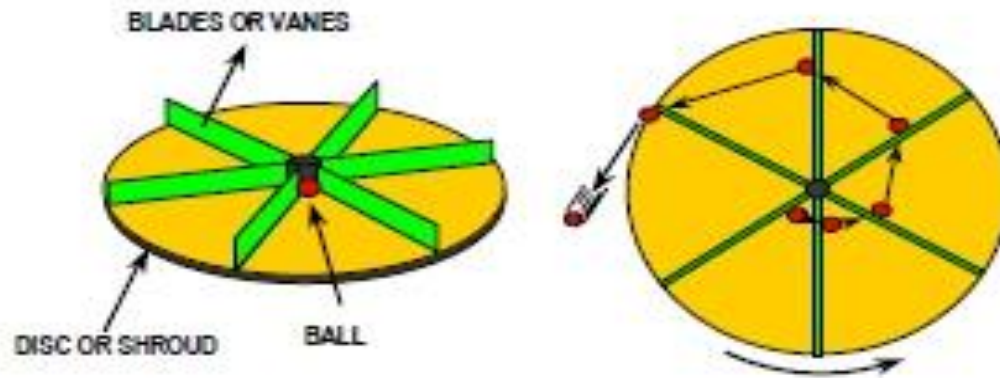

THE DIAGRAM ABOVE SHOWS THE TENDENCY OF AN UNATTACHED BALL TO TRAVEL IN STRAIGHT LINES TOWARD THE OUTER EDGE OF THE DISC AND FLY OFF IN A STRAIGHT LINE AT HIGH VELOCITY, DUE TO THE CENTRIFUGAL FORCE. (NO COUNTER-ACTING CENTRIPETAL FORCE)

IF WE TAKE THE DISC ON THE RIGHT, ABOVE, AND COVER IT WITH ANOTHER SHROUD WE HAVE A CLOSED UNIT CALLED AN 'IMPELLER'.

THE SECOND SHROUD HAS A HOLE IN THE CENTRE WHICH IS REFERRED TO AS THE 'EYE' OF THE IMPELLER. NOW, IF WE REPLACE THE BALL WITH A FLOW OF LIQUID INTO THE EYE AND ROTATE IT AT HIGH SPEED, THE LIQUID WILL FLY AWAY FROM THE RIM OF THE IMPELLER AT HIGH VELOCITY.

WE NOW HAVE THE BEGINNINGS OF THE CONSTRUCTION OF A CENTRIFUGAL PUMP.

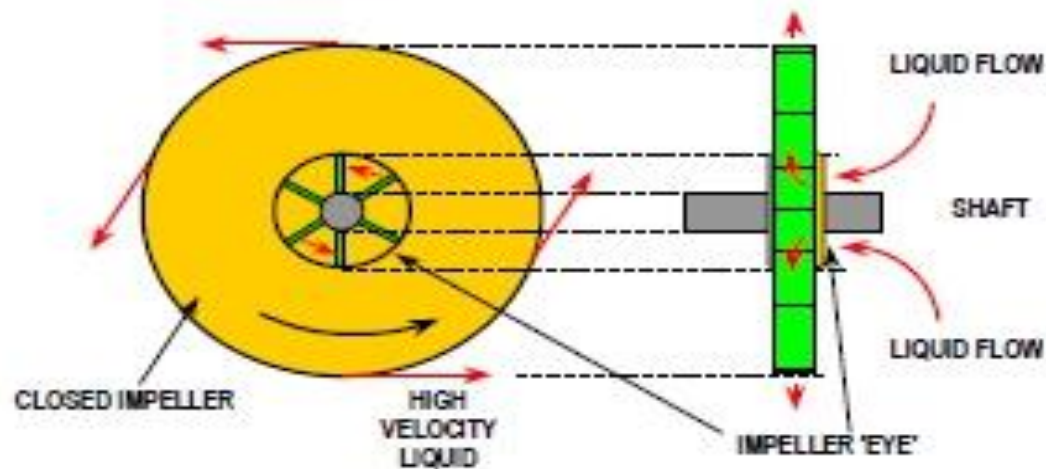

Open Impeller



Semi - Open



Closed

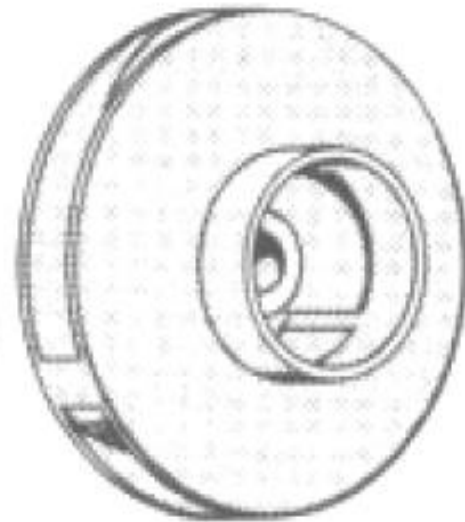

Curved Vanes , Single Shroud and Double Shroud

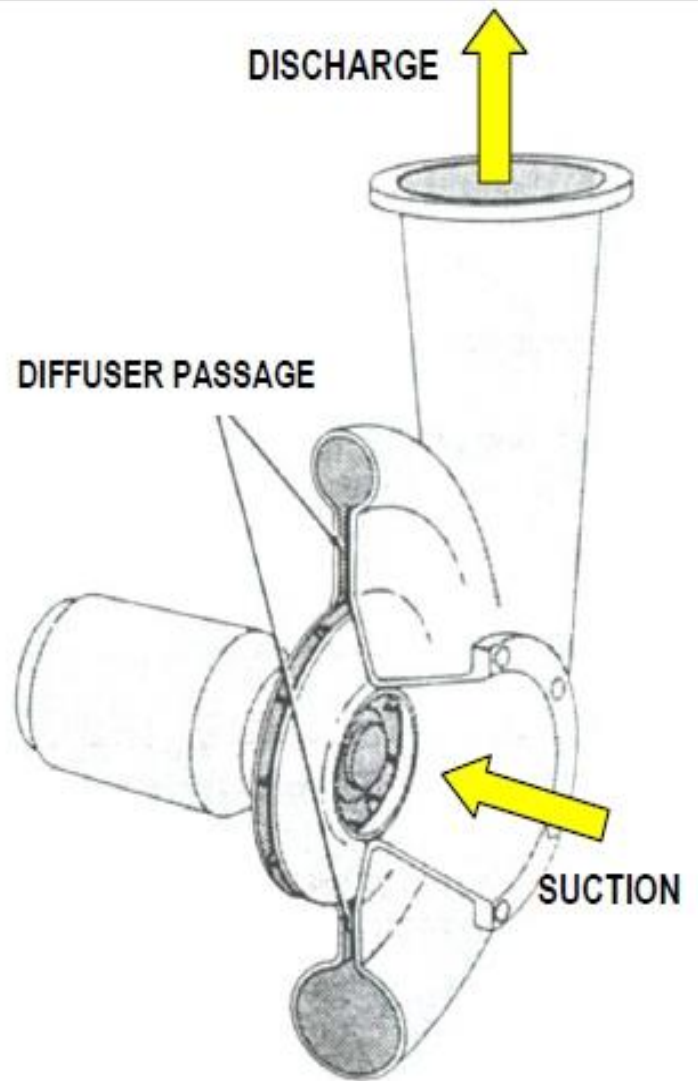
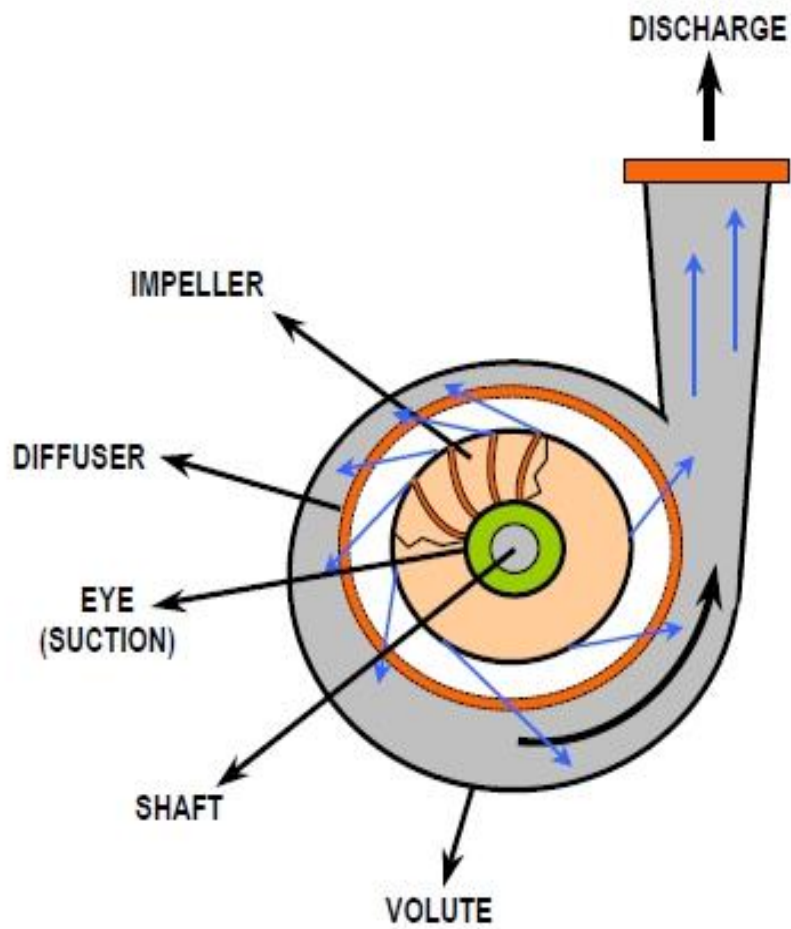



# Centrifugal Impellers

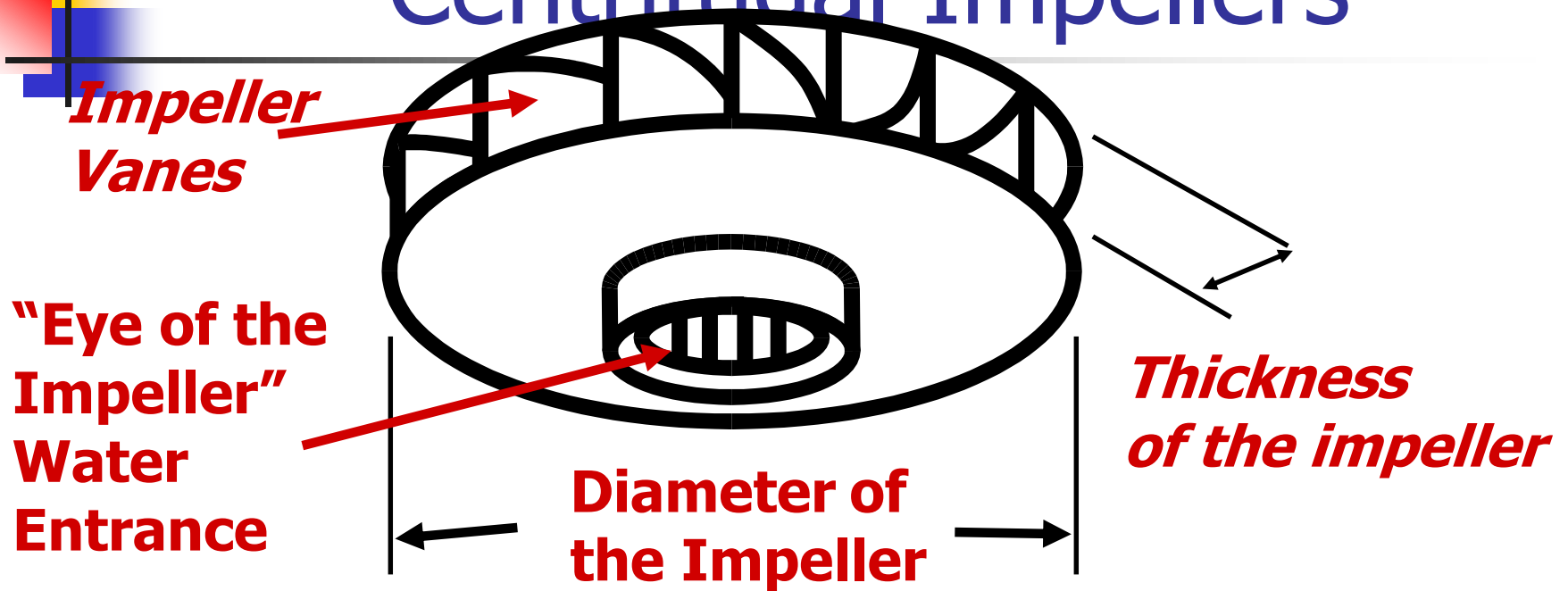

- Thicker the Impeller- More Water
- Larger the DIAMETER - More Pressure
- Increase the Speed - More Water and Pressure

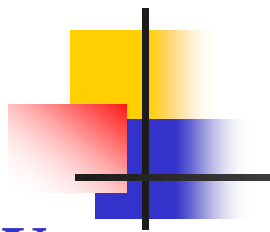

---

**Vapor pressure** (also known as *equilibrium vapor pressure*), is the pressure of a vapor in equilibrium with its non-vapor phases. All liquids and solids have a tendency to evaporate to a gaseous form, and all gases have a tendency to condense back into their original form (either liquid or solid). At any given temperature, for a particular substance, there is a pressure at which the gas of that substance is in dynamic equilibrium with its liquid or solid forms. This is the vapor pressure of that substance at that temperature. The equilibrium vapor pressure is an indication of a liquid's evaporation rate. It relates to the tendency of molecules and atoms to escape from a liquid or a solid. A substance with a high vapor pressure at normal temperatures is often referred to as volatile.

# Centrifugal Pump - Vapour Pressure

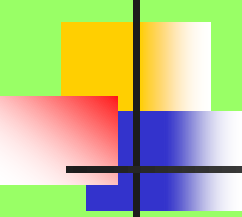

---

**Vapor pressure is the pressure at which a liquid and its vapor co-exist in equilibrium, at a given temperature. Vaporization begins when the vapor pressure of the liquid at the operating temperature equals the external system pressure, which in an open system always equal to the atmospheric pressure. Any decrease in external pressure or rise in operating temperature can induce vaporization and the pump stops pumping.**

# Centrifugal Pump (Rotodynamic)

**Centrifugal pump distinguished from  
Positive displacement pump -----**

- Requirement of relative velocity between the fluid and the impeller.
- Shaped casing or diverging nozzle converts kinetic energy into pressure energy.
- Liquid in the impeller and casing essential for pump operation.

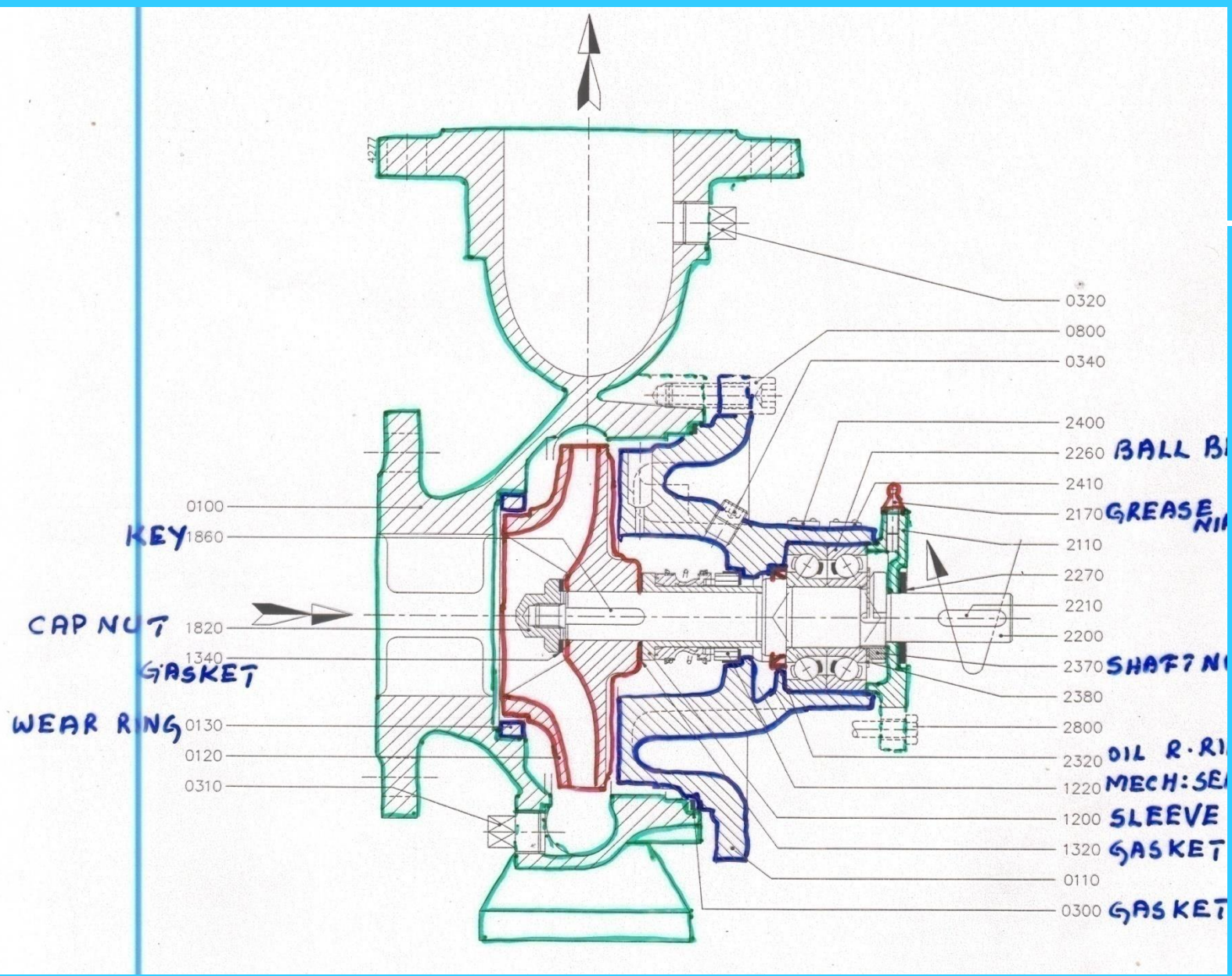
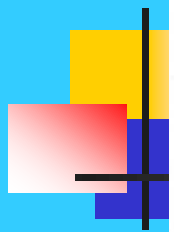

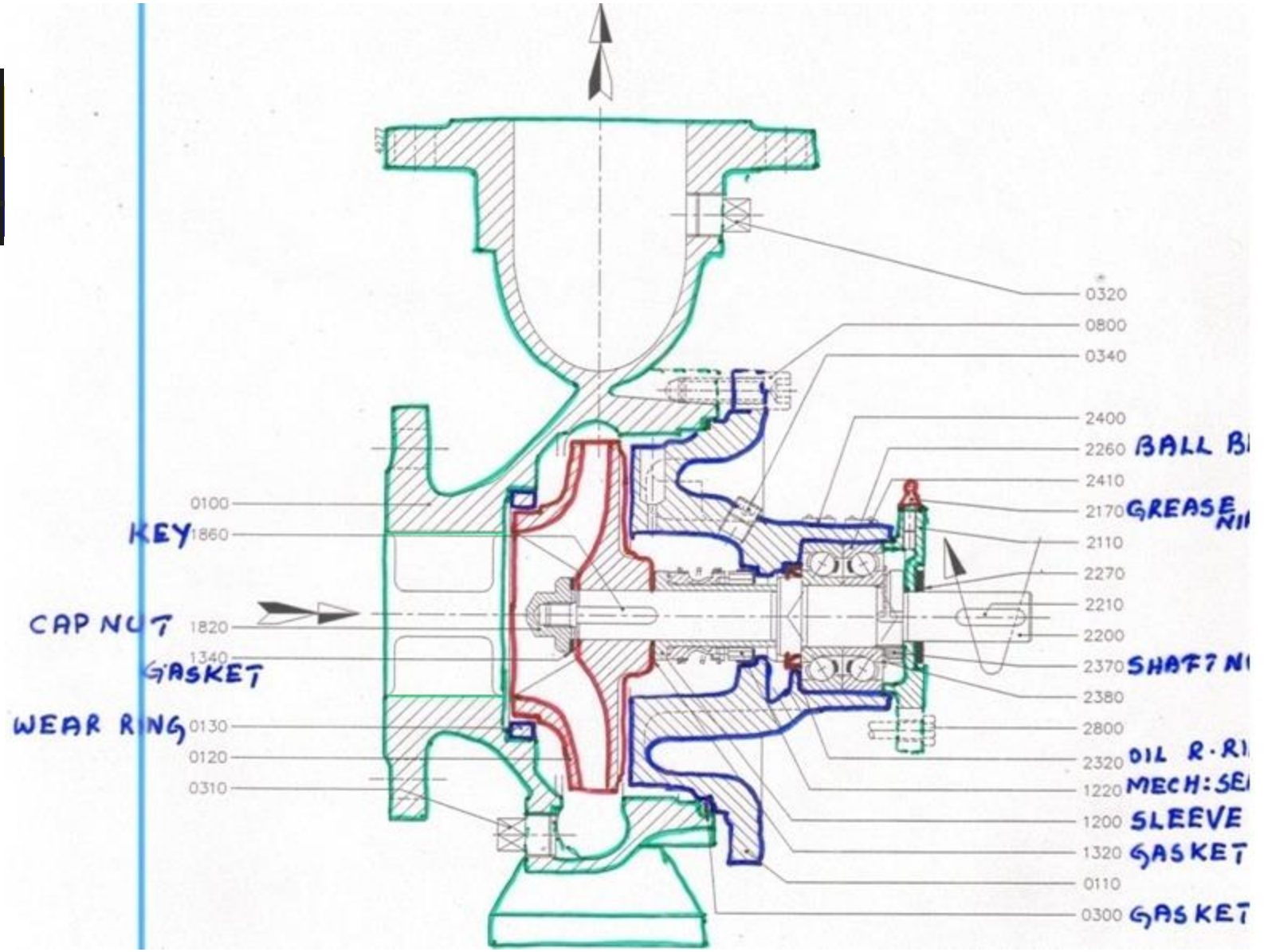

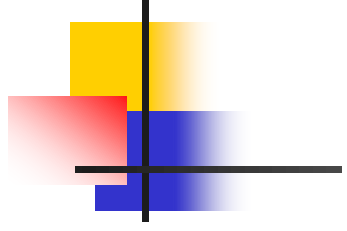
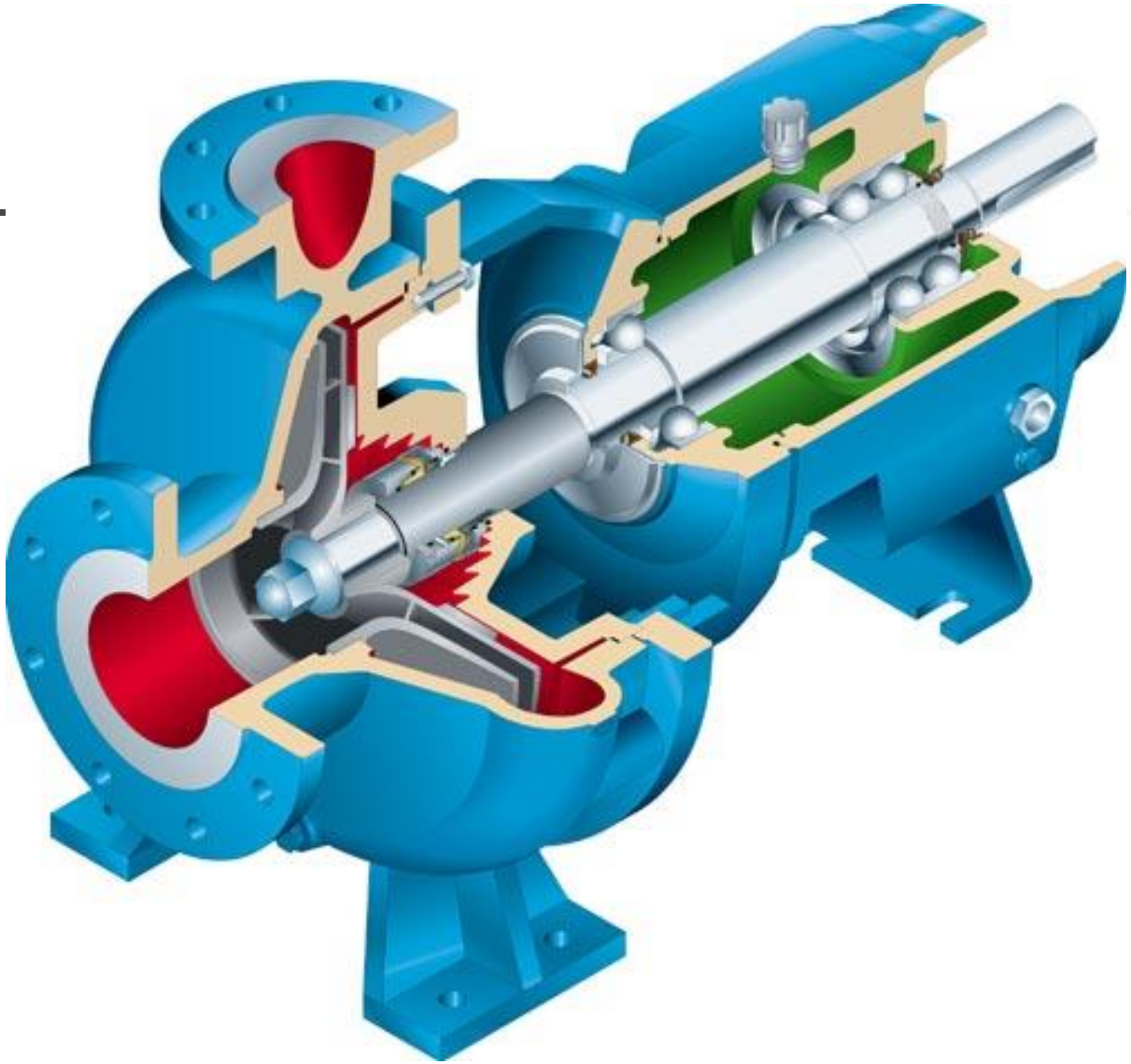

# CENTRIFUGAL P/P

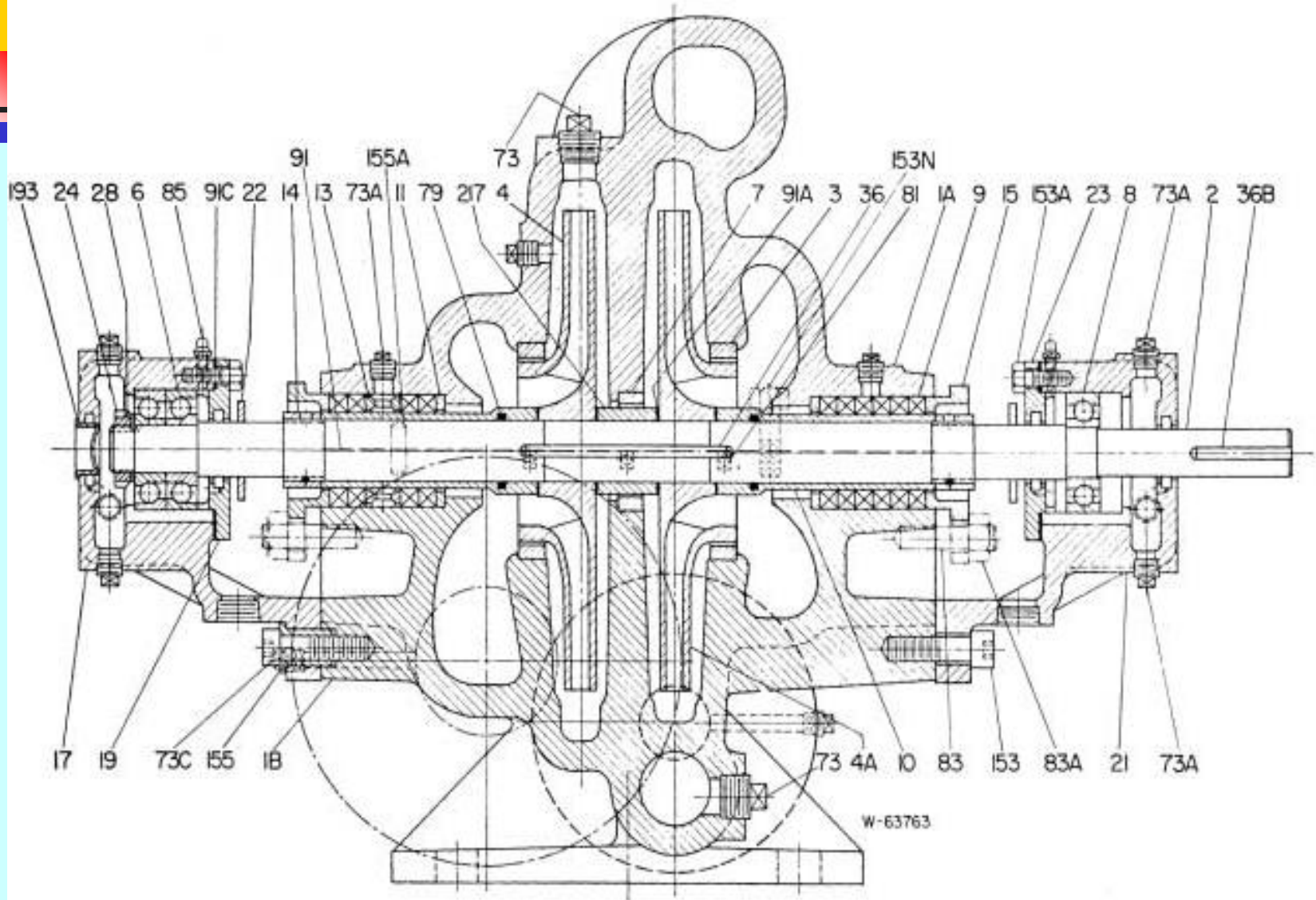





# Pump

As a special feature the spacer model is equipped with a coupling which is a combined distance and flexible coupling making it possible to remove the complete bearing housing with shaft, bearings, shaft seal, and impeller without dismantling or loosening the motor or piping.



# Base Mounted Centrifugal End Suction Fire Pump

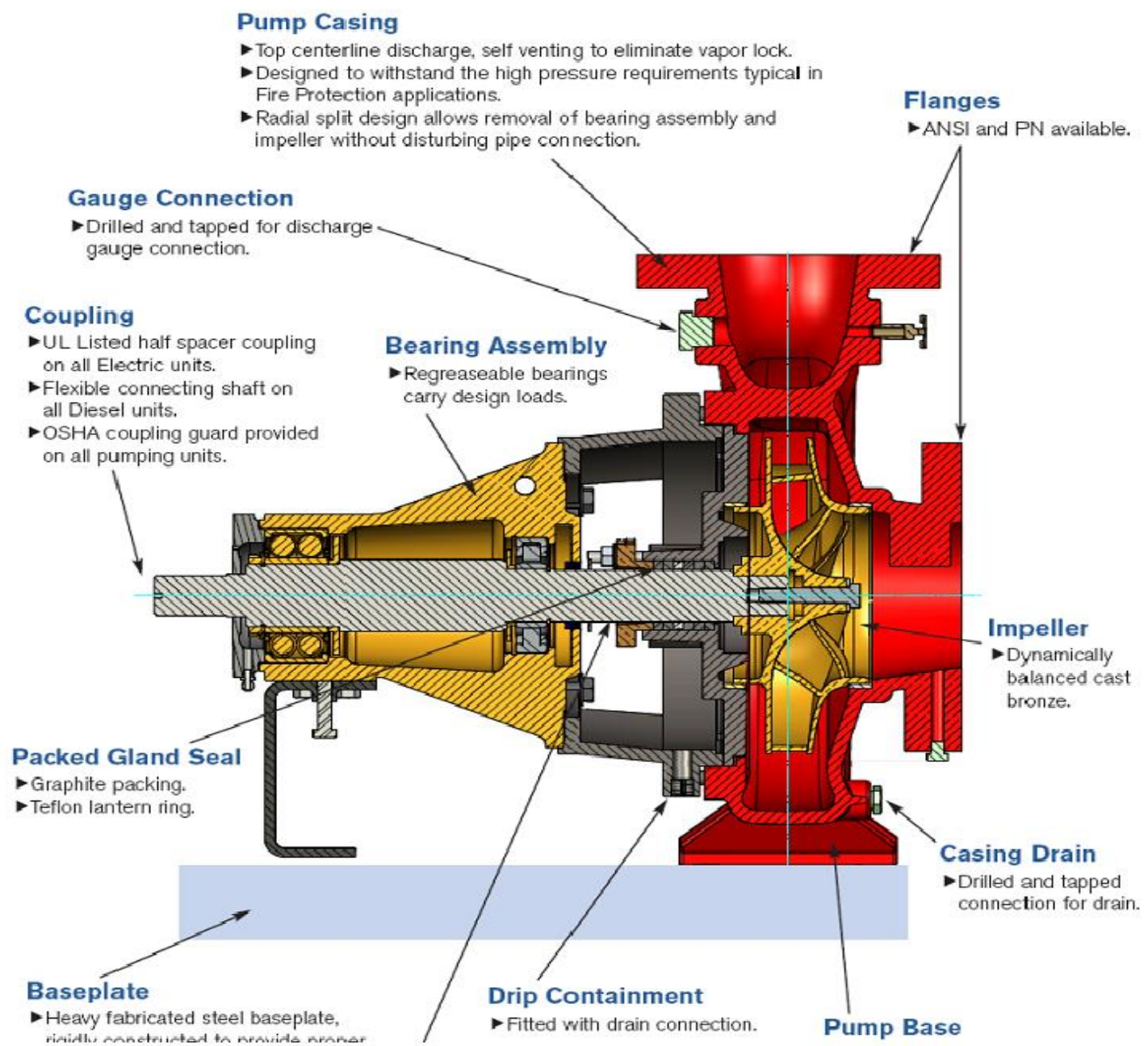
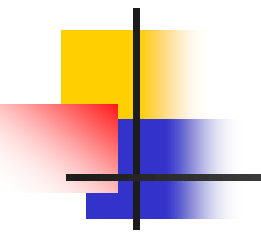

# Centrifugal Pump- Theory

- ❑ The energy changes occur in a centrifugal pump by virtue of two main parts of the pump.
- ❑ The Impeller – The rotating part that converts driver energy into kinetic energy.
- ❑ The volute or Diffuser – The stationary part that converts the kinetic energy into pressure energy.
- ❑ The process liquid enters the suction nozzle and then into the eye of the impeller. Impeller spins the liquid sitting in the cavities between the vanes, outwards and provides centrifugal acceleration. As liquid leaves the eye of the impeller, a low pressure area is created, causing more liquid to flow towards the inlet. Because the impeller blades are curved, the fluid is pushed in a tangential and radial direction by the centrifugal forces.

# Centrifugal Pump - Theory

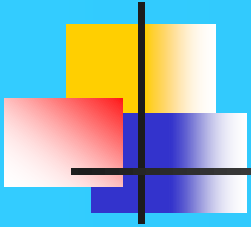

**The amount of energy given to the liquid is proportional to the velocity at the edge or vane tip of the impeller. The faster the impeller revolves or bigger the impeller is, then higher will be the velocity of the liquid at the vane tip and greater the energy imparted to the liquid.**

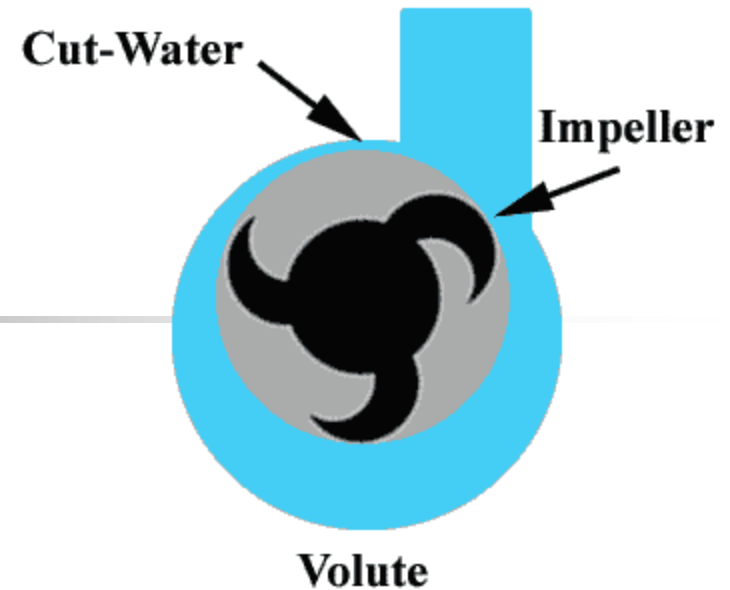
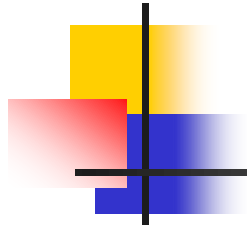

### **Centrifugal Pump Components**

**The two main components of a centrifugal pump are the impeller and the volute. The impeller produces liquid velocity and the volute forces the liquid to discharge from the pump converting velocity to pressure. This is accomplished by offsetting the impeller in the volute and by maintaining a close clearance between the impeller and the volute at the cut-water. Please note the impeller rotation. A centrifugal pump impeller slings the liquid out of the volute. It does not cup the liquid.**



# Centrifugal Pump - Head

---

**The pressure at any point in a liquid can be thought of as being caused by a vertical column of the liquid due to its weight. The height of this column is called the static head and is expressed in terms of meters of liquid. Head is a measurement of height of a liquid column that a pump could create from kinetic energy imparted to the liquid. Imagine a pipe shooting a jet of water straight up into the air, the height the water goes up would be the head.**

# Centrifugal Pump – Velocity Head

---

Velocity Head refers to the energy of a liquid as a result of its motion at some velocity,  $V$ . It is the equivalent head in meters through which the water would have to fall to acquire the same velocity or the head necessary to accelerate the water.

Velocity head is insignificant in most high head systems, but it can be large in low head systems.





# Factors Affecting Suction Lift

---

- Temperature and volatility of the fluid**
- Pressure exerted on the free side of the liquid.**
- Friction Losses at entrances, bends and pipes in the suction system.**

# FACTORS AFFECTING P/P CAPACITY

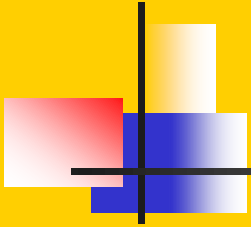

- PROCESS LIQUID CHARACTERISTICS – DENSITY, VISCOSITY
- SIZE OF THE PUMP AND ITS INLET AND OUTLET SECTIONS
- IMPELLER SIZE
- IMPELLER ROTATIONAL SPEED
- SIZE AND SHAPE OF CAVITIES BETWEEN THE VANES
- PUMP SUCTION AND DISCHARGE PRESSURE AND TEMPERATURE CONDITIONS



# Priming of Centrifugal Pump.

---

Priming is the process of removing Air/Vapour and filling the suction piping, impeller and pump casing with the fluid.

## **METHODS OF PRIMING**

- ✓ Liquid ring air-pump.
- ✓ Ejector.
- ✓ Reciprocating Pump. – Obsolete.

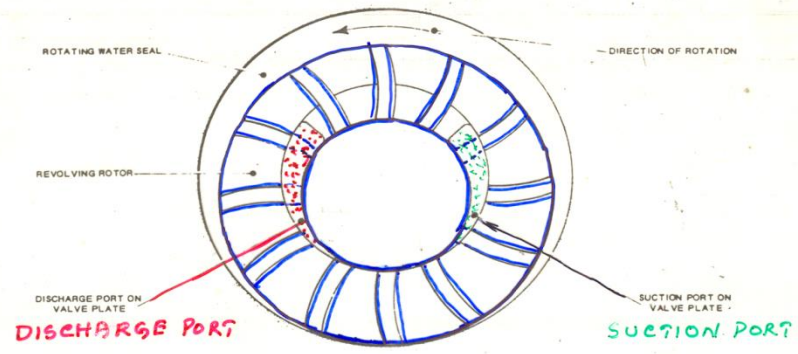

SINGLE THROW AIR PUMP

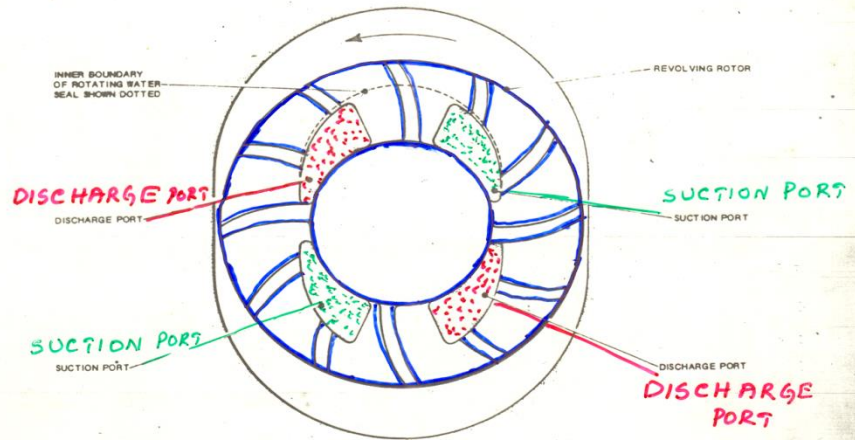

DOUBLE THROW AIR PUMP

LIQUID RING PRIMER

FIG. I AIR PUMPS - PRINCIPLE OF OPERATION

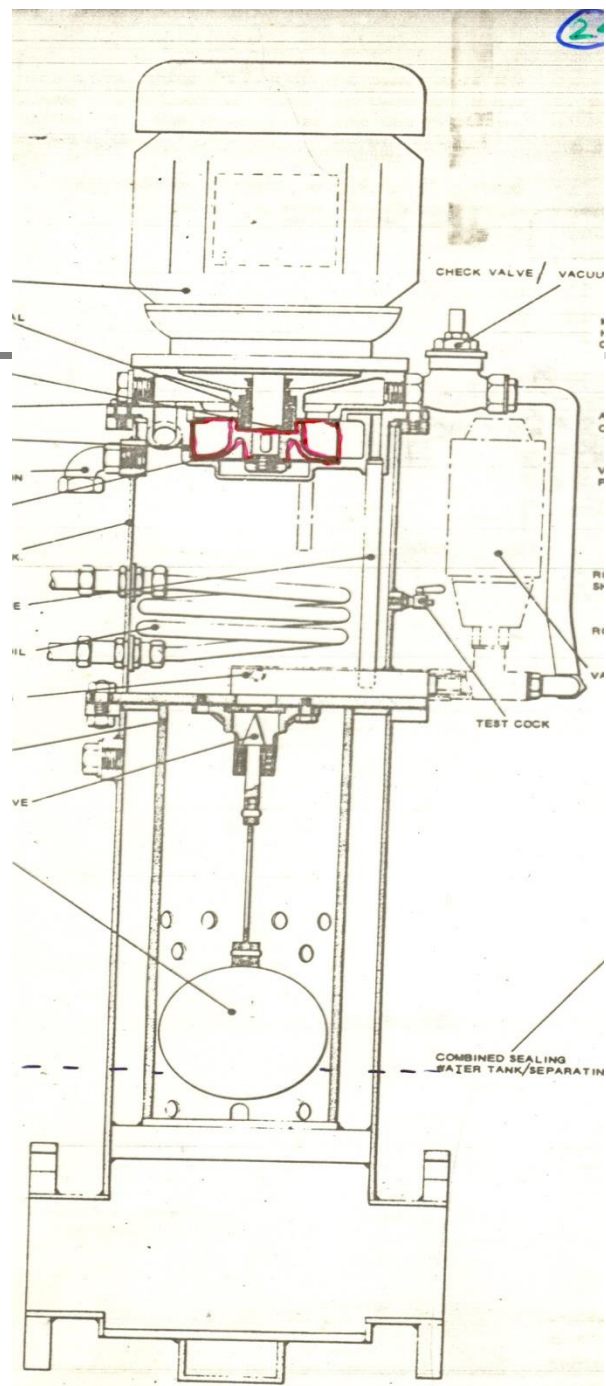
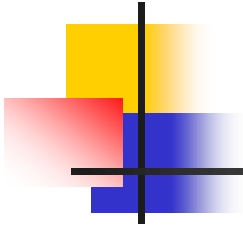

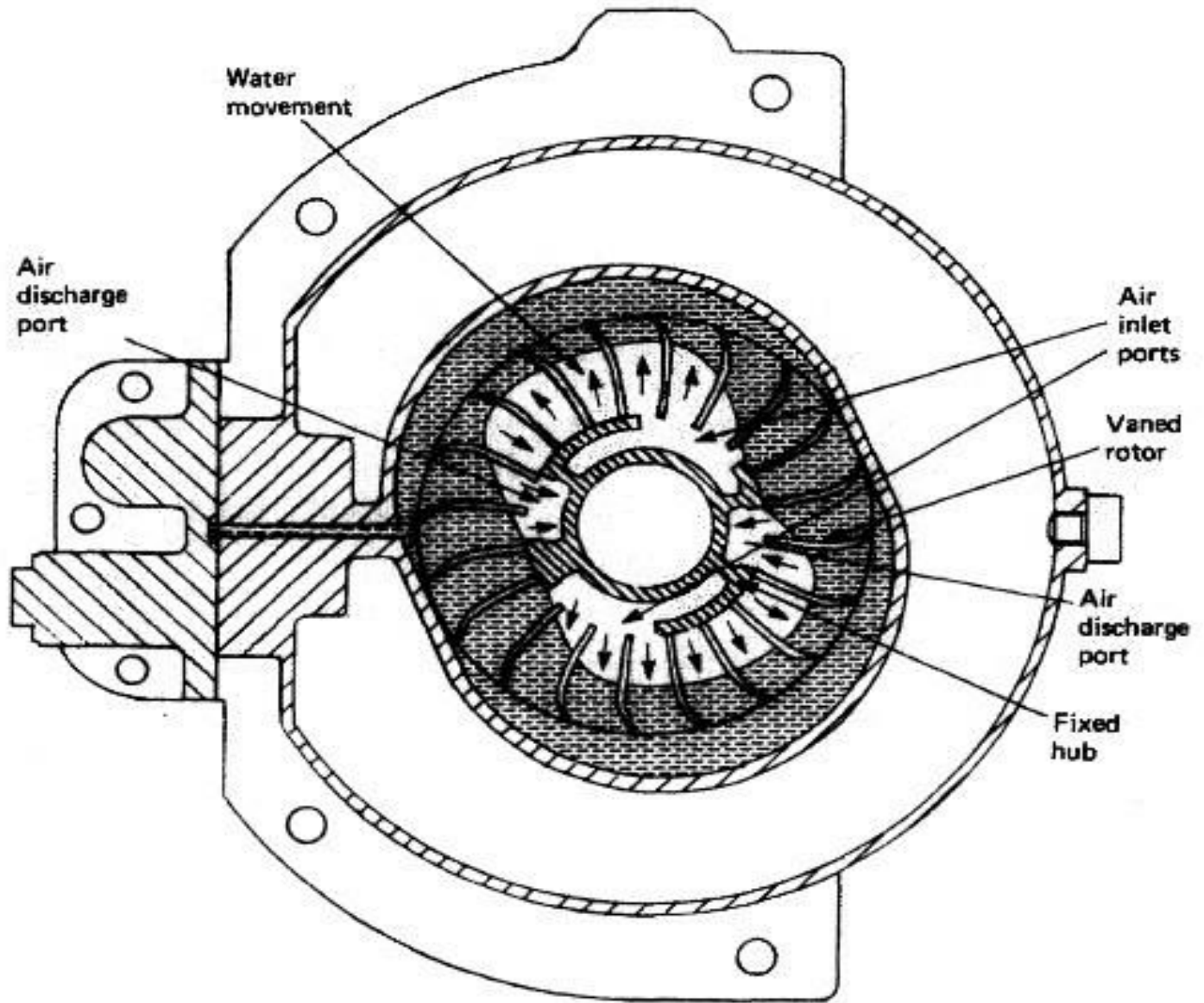

On pumps in essential services, the fitting of a non-return valve in the pump priming line is recommended to prevent air being drawn into the pump through the vacuum tank priming line due to malfunctioning of the central priming system

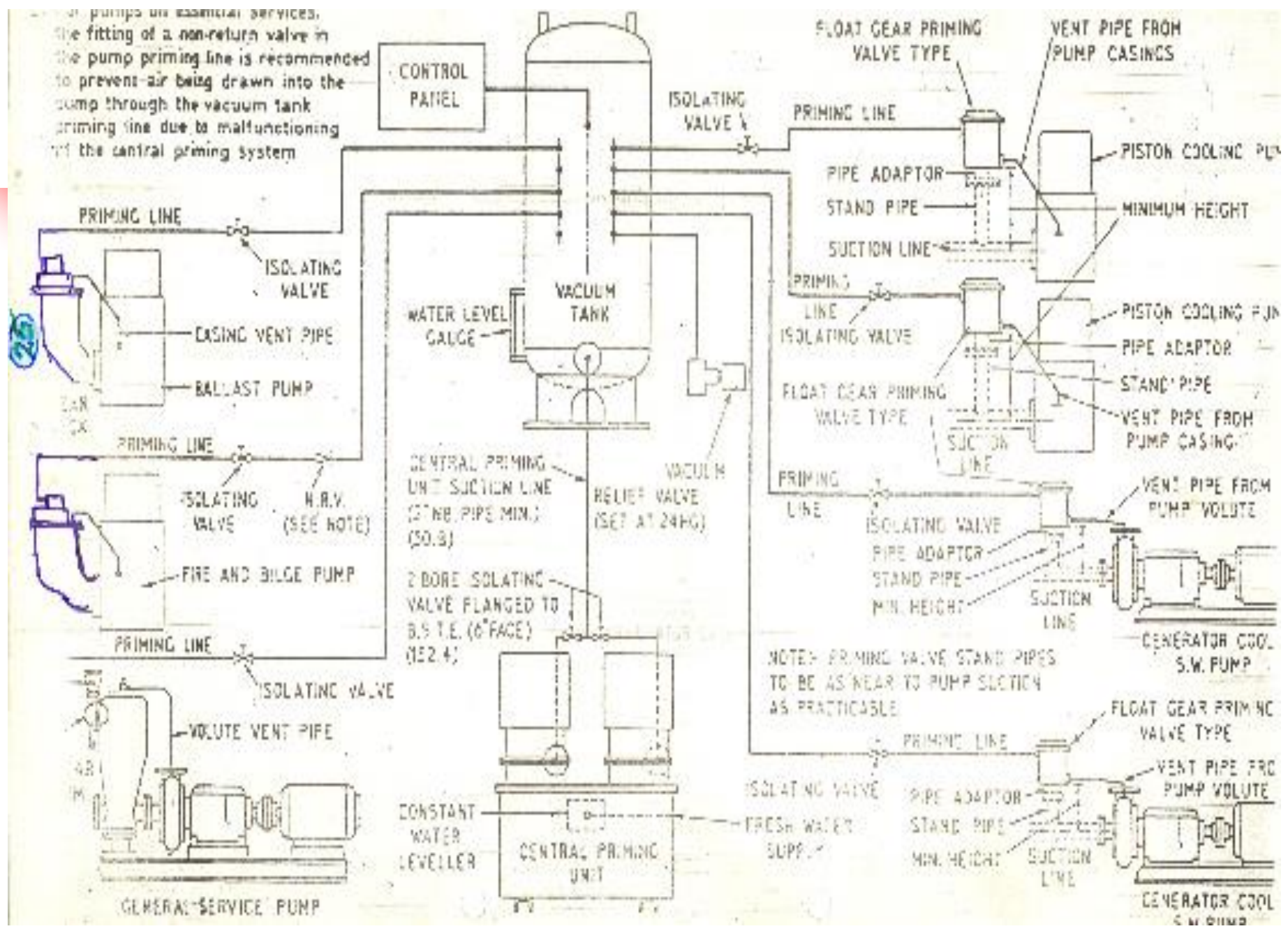

Déchargement des citernes latérales & lavages au brut des citernes centrales (disch -wings tanks & COW to cent-tks)

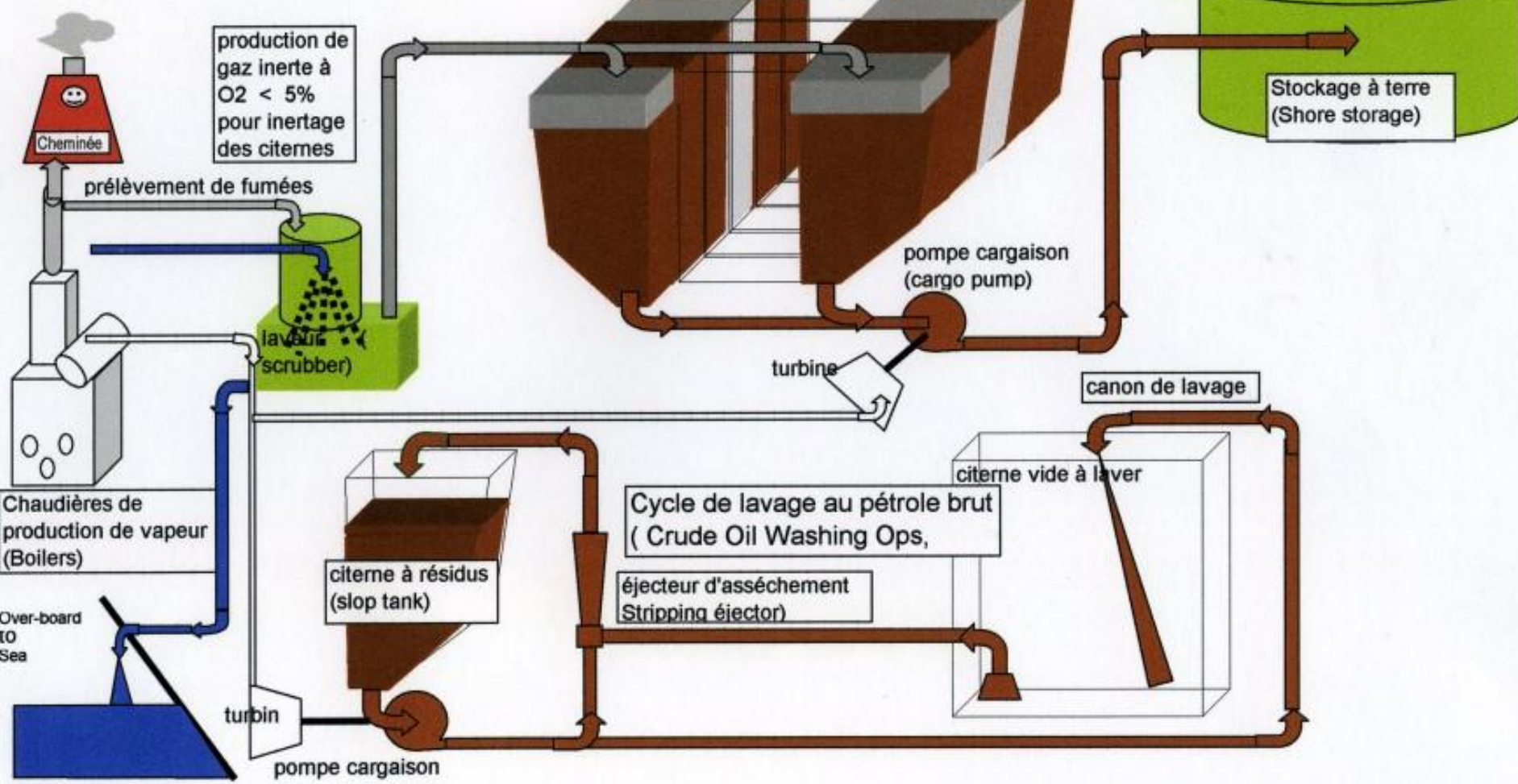



# AUTOMATIC UNLOADING SYSTEM

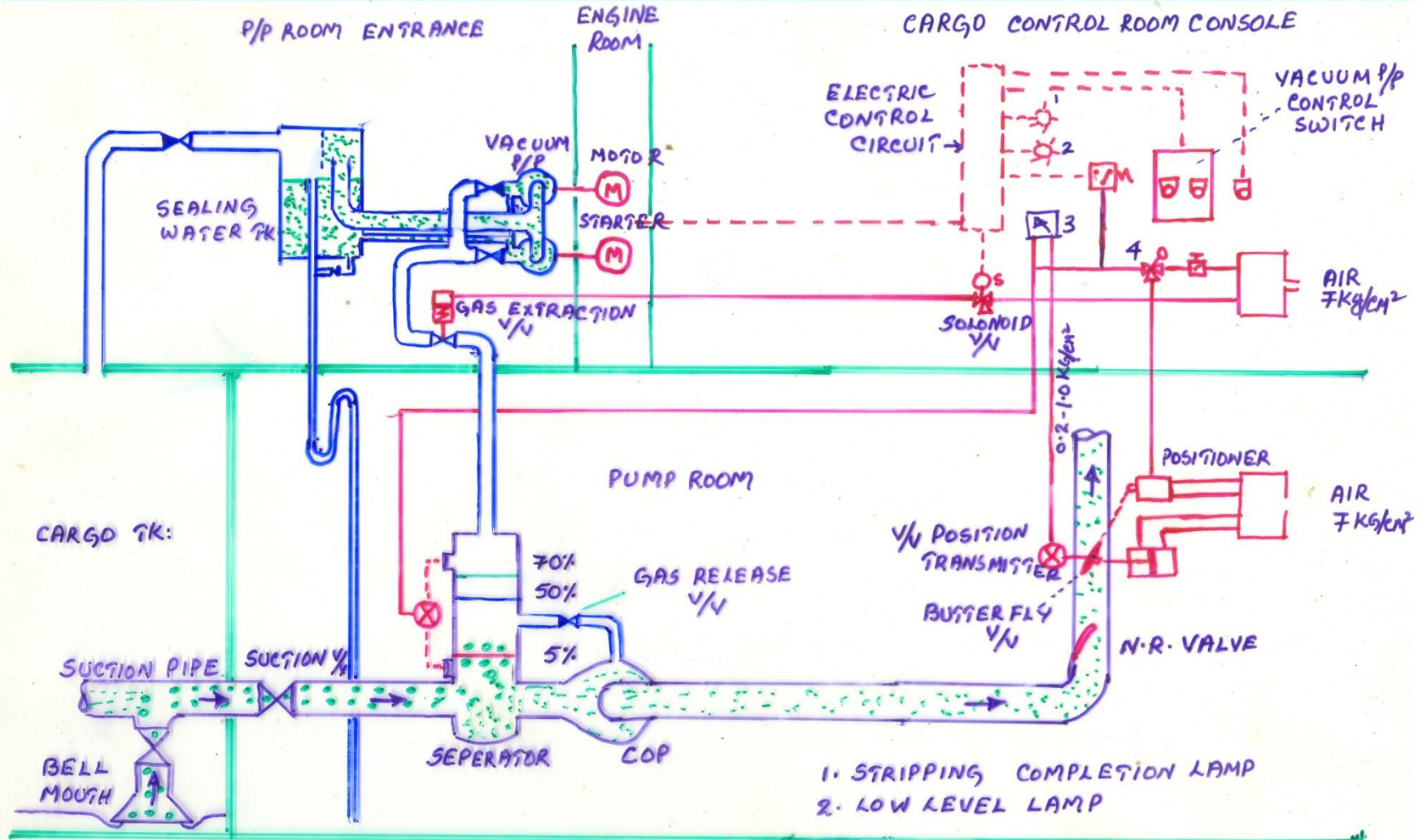

1. STRIPPING COMPLETION LAMP
2. LOW LEVEL LAMP
3. SEPERATOR LEVEL & V/V POSITION GAUGE
4. DISCHARGE CV AM SELECTOR

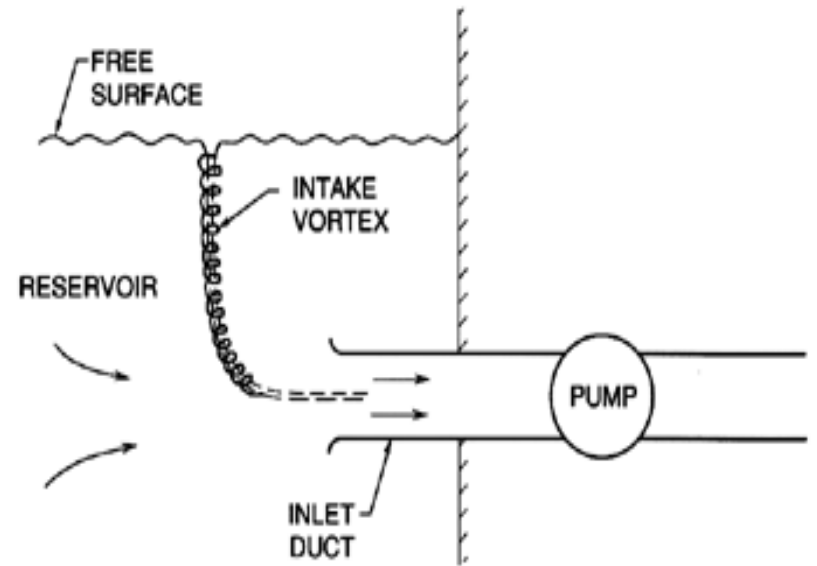
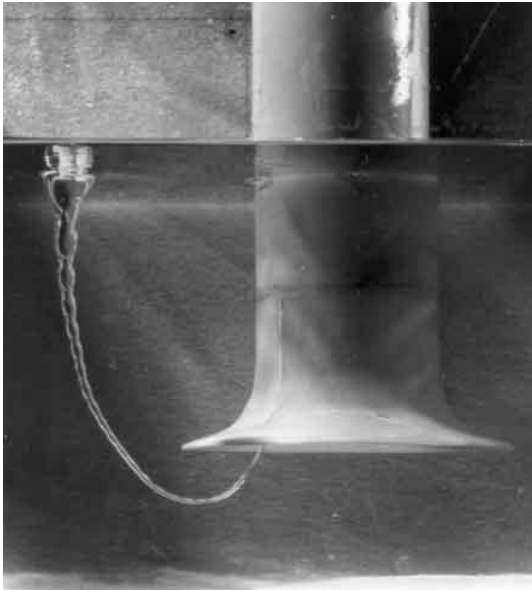

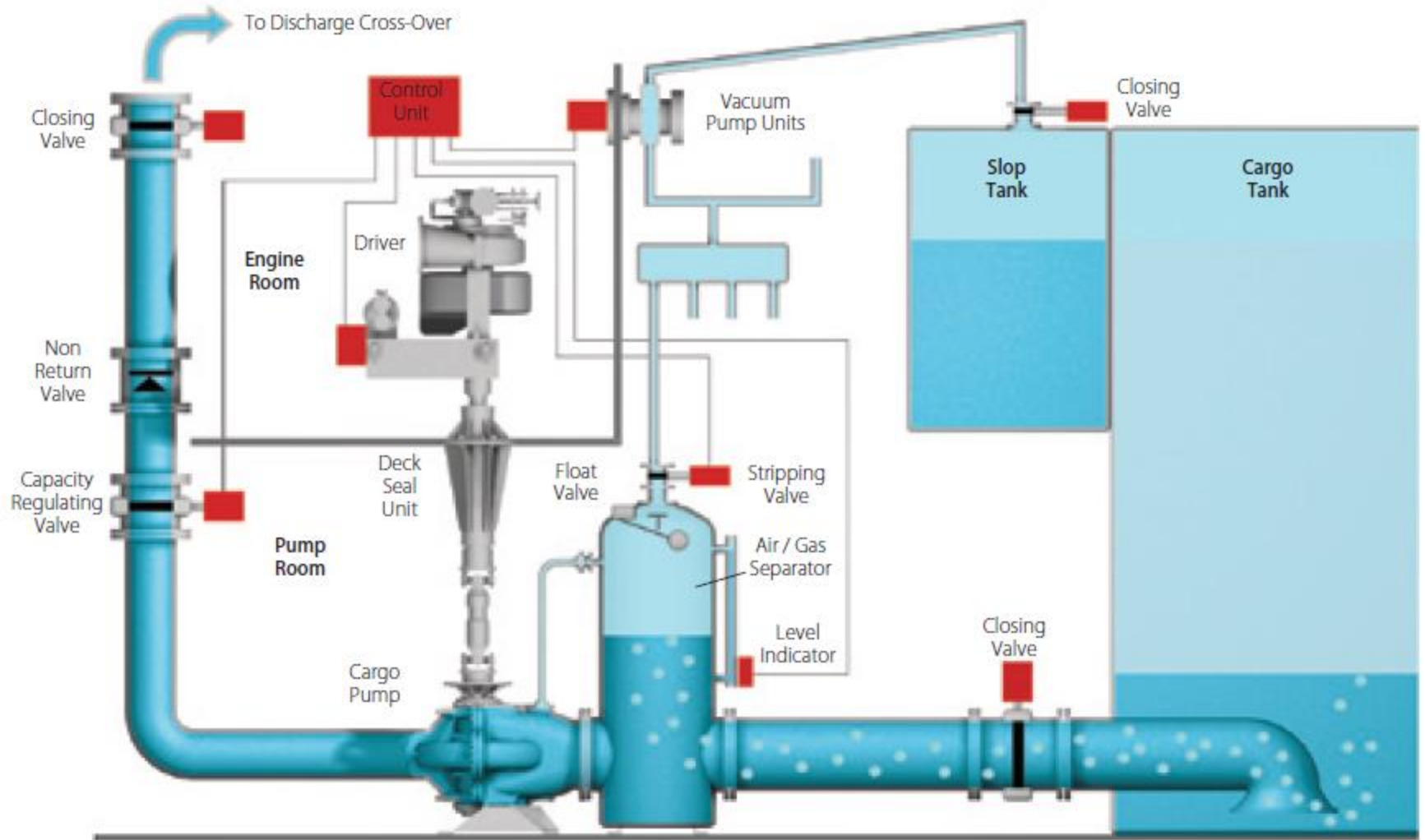

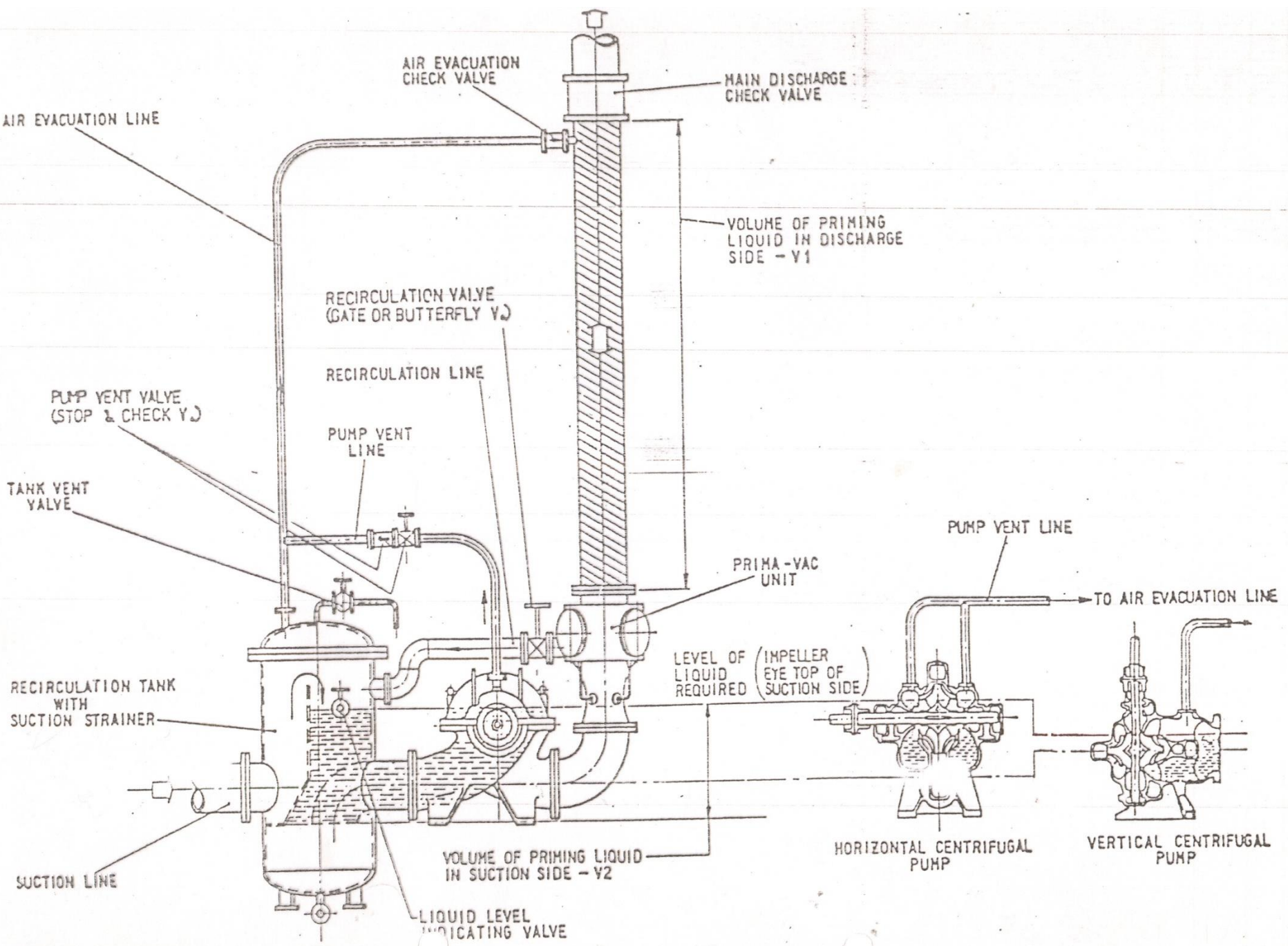

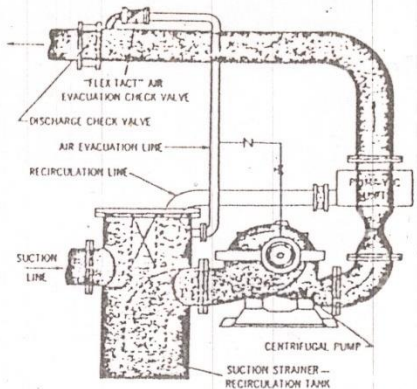

Fig. 3 - NORMAL OPERATION

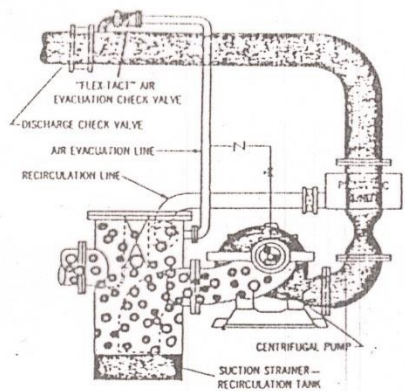

Fig. 4 - LOSS OF SUCTION

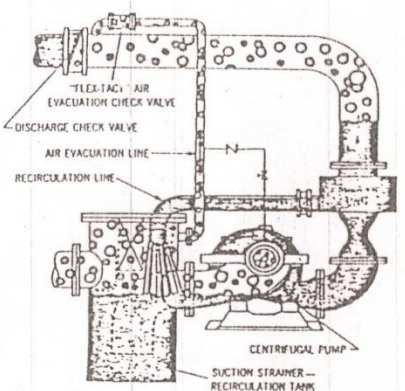

Fig. 5 - RECIRCULATION

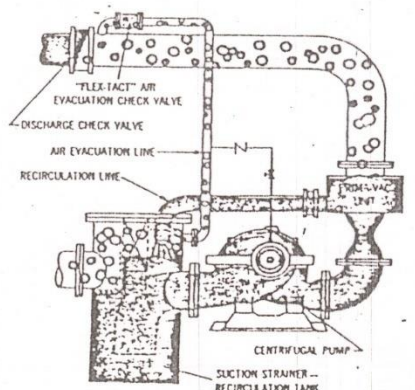

Fig. 6 - REPRIMING COMPLETE

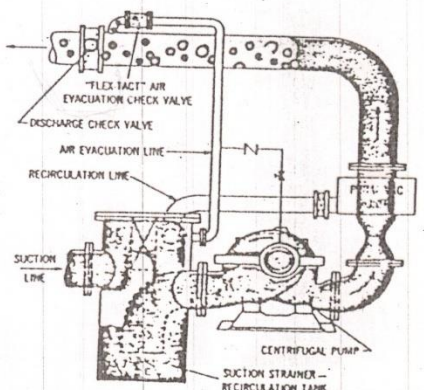
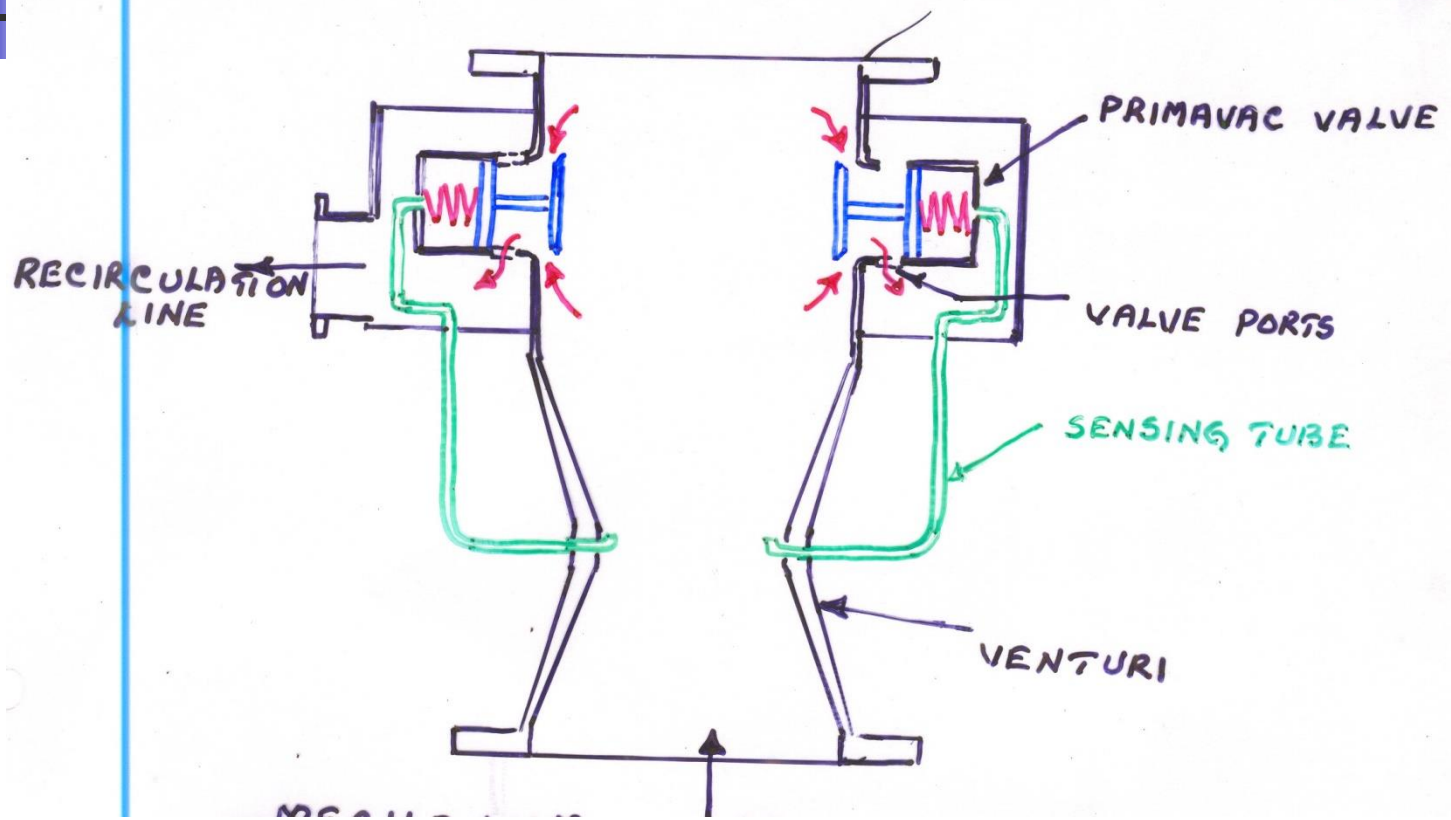
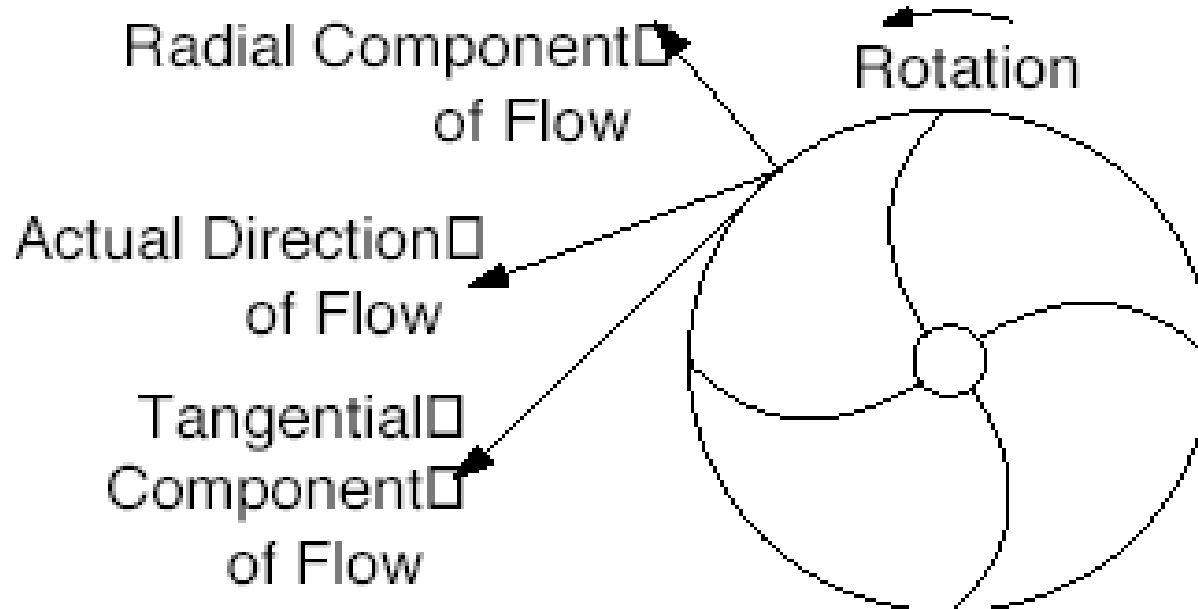

Fig. 7 - PUMPING RESUMED

— PRIMAVAC SYSTEM —



# Impeller of Centrifugal Pump



**FIGURE 25. Liquid Flow Direction**

# Types of Impellers, With Respect to Flow.

- Radial flow.
- Axial flow.
- Mixed flow.

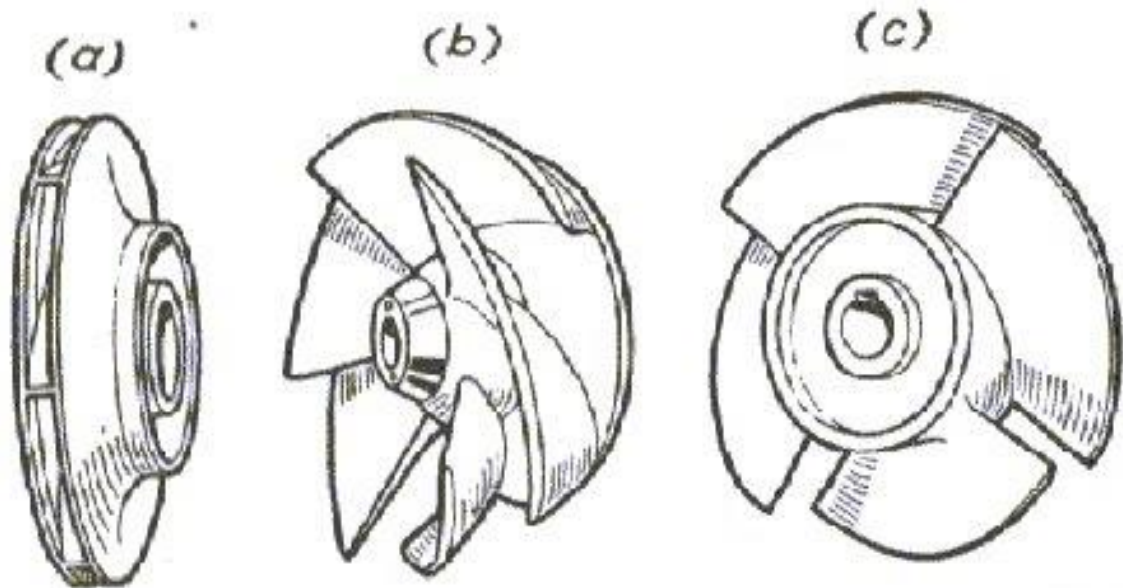

Rotors for rotodynamic pumps: (a) radial-flow for centrifugal pump; (b) mixed-flow; (c) axial-flow



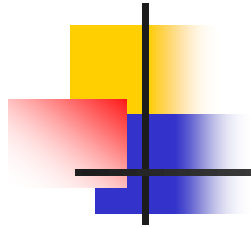

**Radial Flow - a centrifugal pump in which the pressure is developed wholly by centrifugal force.**

**Mixed Flow - a centrifugal pump in which the pressure is developed partly by centrifugal force and partly by the lift of the vanes of the impeller on the liquid.**

**Axial Flow - a centrifugal pump in which the pressure is developed by the propelling or lifting action of the vanes of the impeller on the liquid.**



# Axial Flow Pump

---

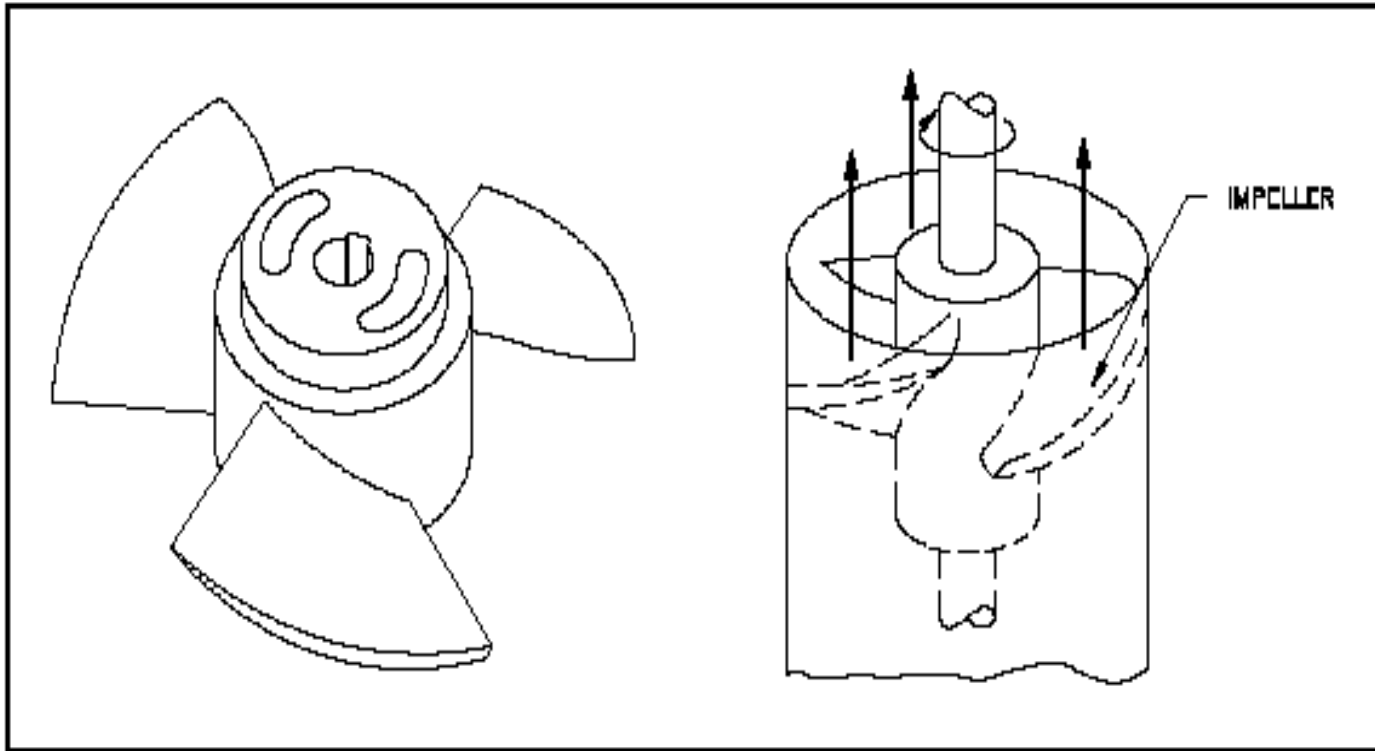



# Mixed Flow Pump

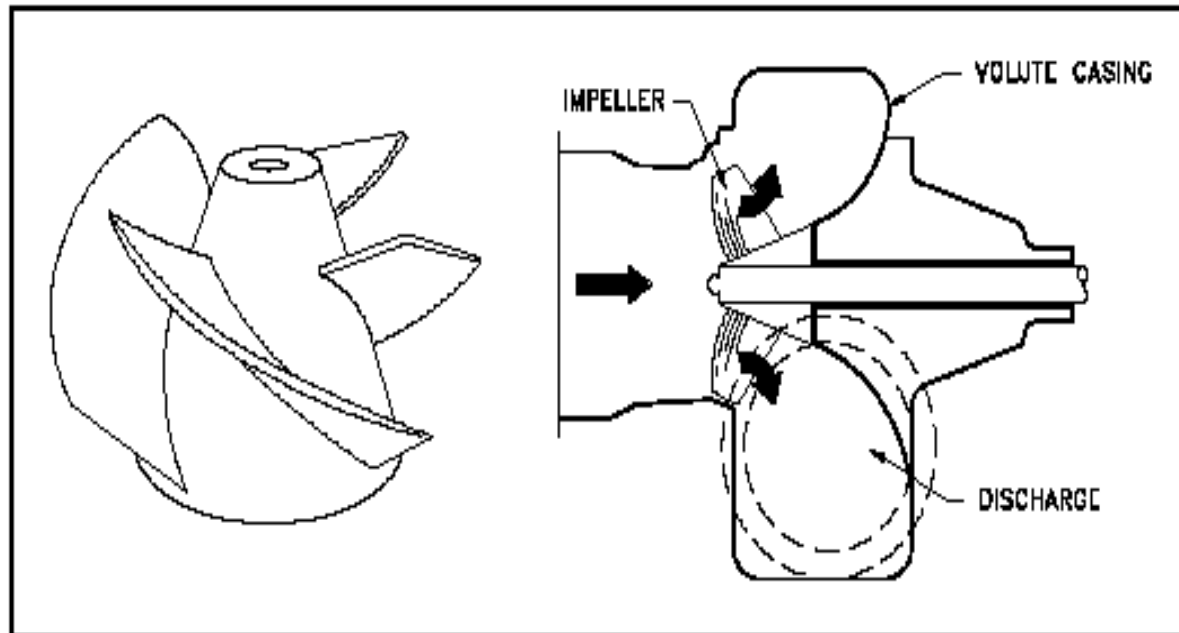

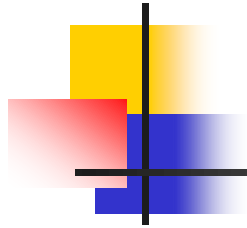

For low flows and high pressures, the action of the impeller is largely radial. For higher flows and lower discharge pressures, the direction of the flow within the pump is more nearly parallel to the axis of the shaft, and the pump is said to have an axial flow. The impeller in this case acts as a propeller. The transition from one set of flow conditions to the other is gradual, and for intermediate conditions, the device is called a mixed-flow pump. Conical designs also featured in the transition from radial to axial flow conditions.

<b>Specific Speed Range</b>	<b>Pump Type</b>
Below 5,000	Radial Flow Pumps
4,000 - 10,000	Mixed Flow Pumps
9,000 - 15,000	Axial Flow Pumps

# Types of Impellers With Respect to Construction.

- **Open** (with partial shrouds for strength. -  
- For abrasive liquids with suspended solids.
- **Semi-Open** - - For viscous liquids.
- **Enclosed** - - For clear liquids.

# Centrifugal Pump - Impellers



13 **Shroud** - The front and /or back of an impeller.

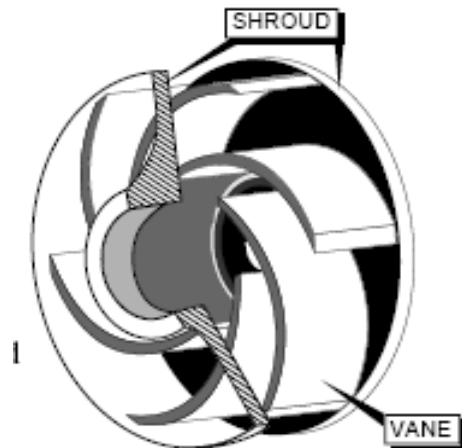

# Open, Semi-open and enclosed Impellers

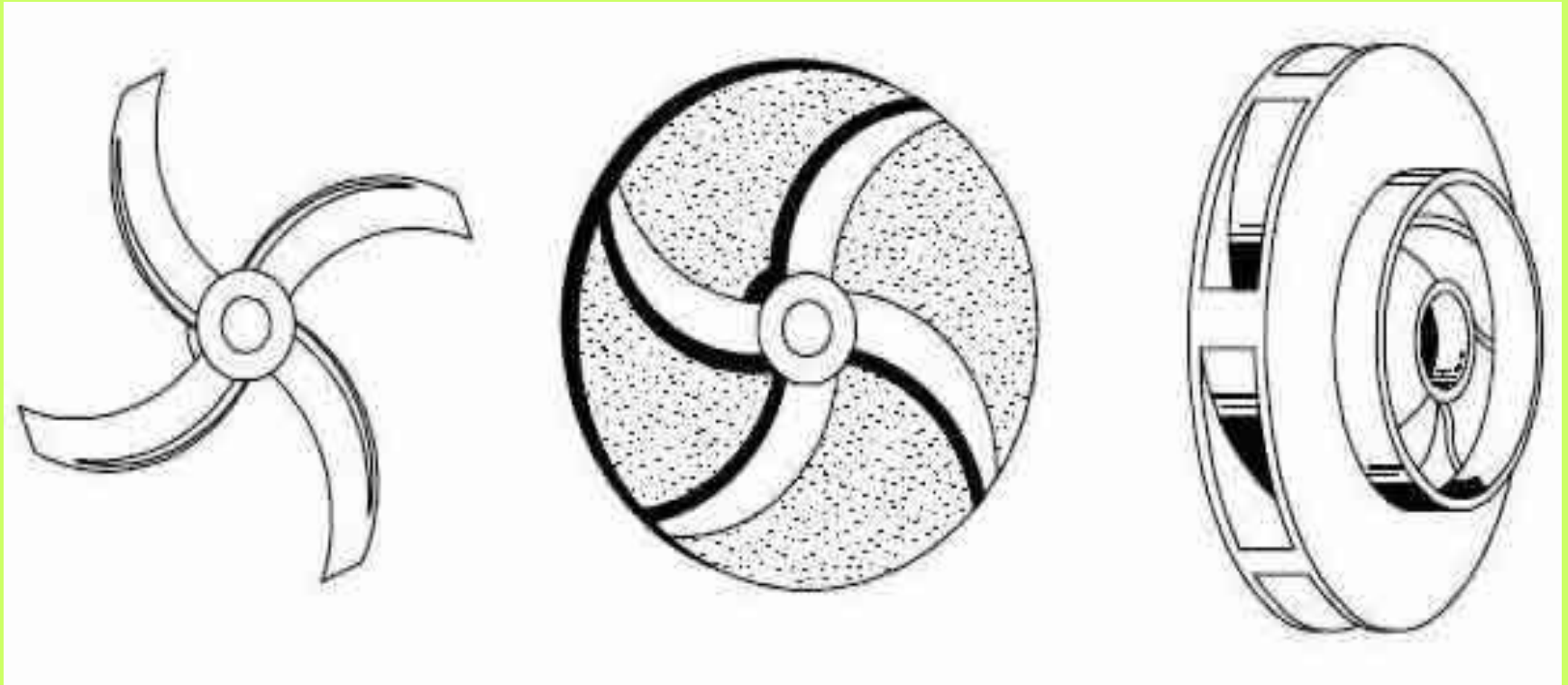
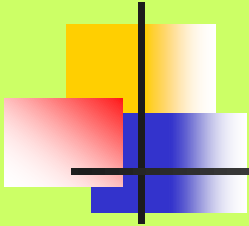



# Open, Semi-open, Enclosed

---

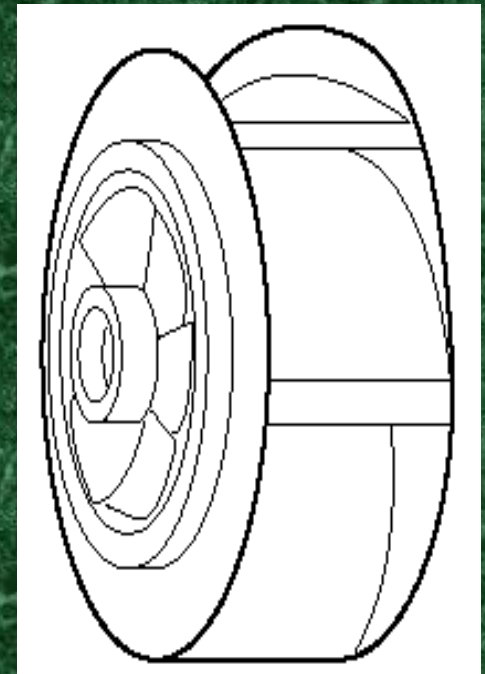
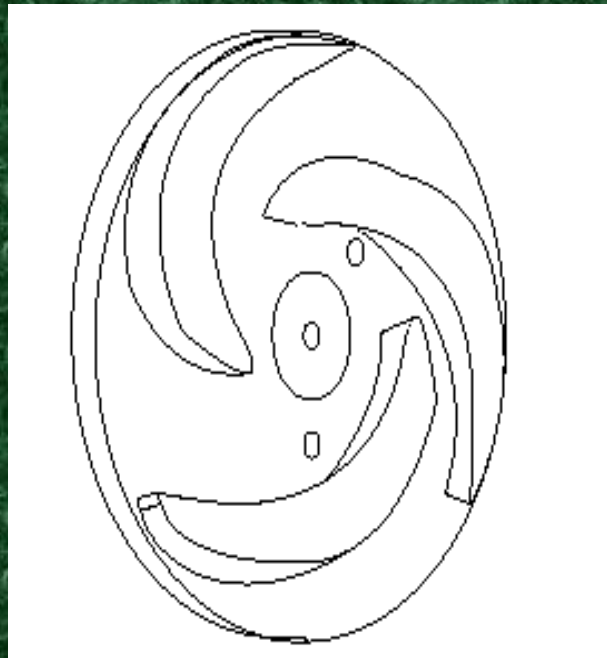
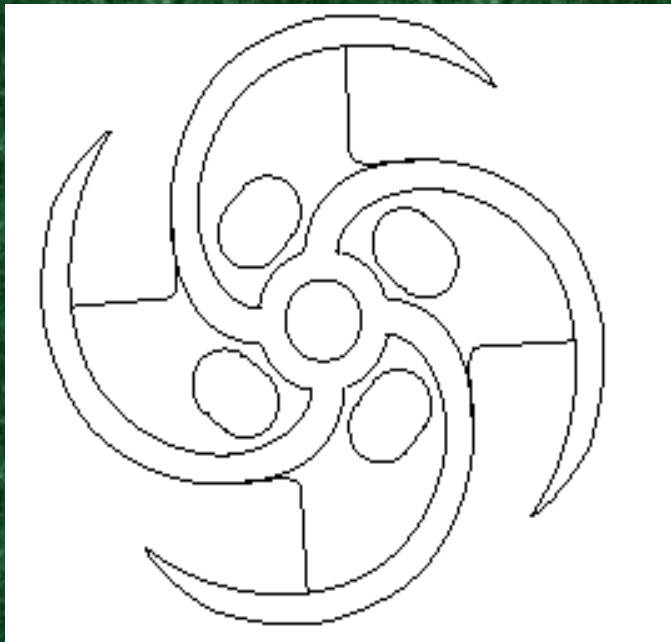



# Single and Double Entry Impellers

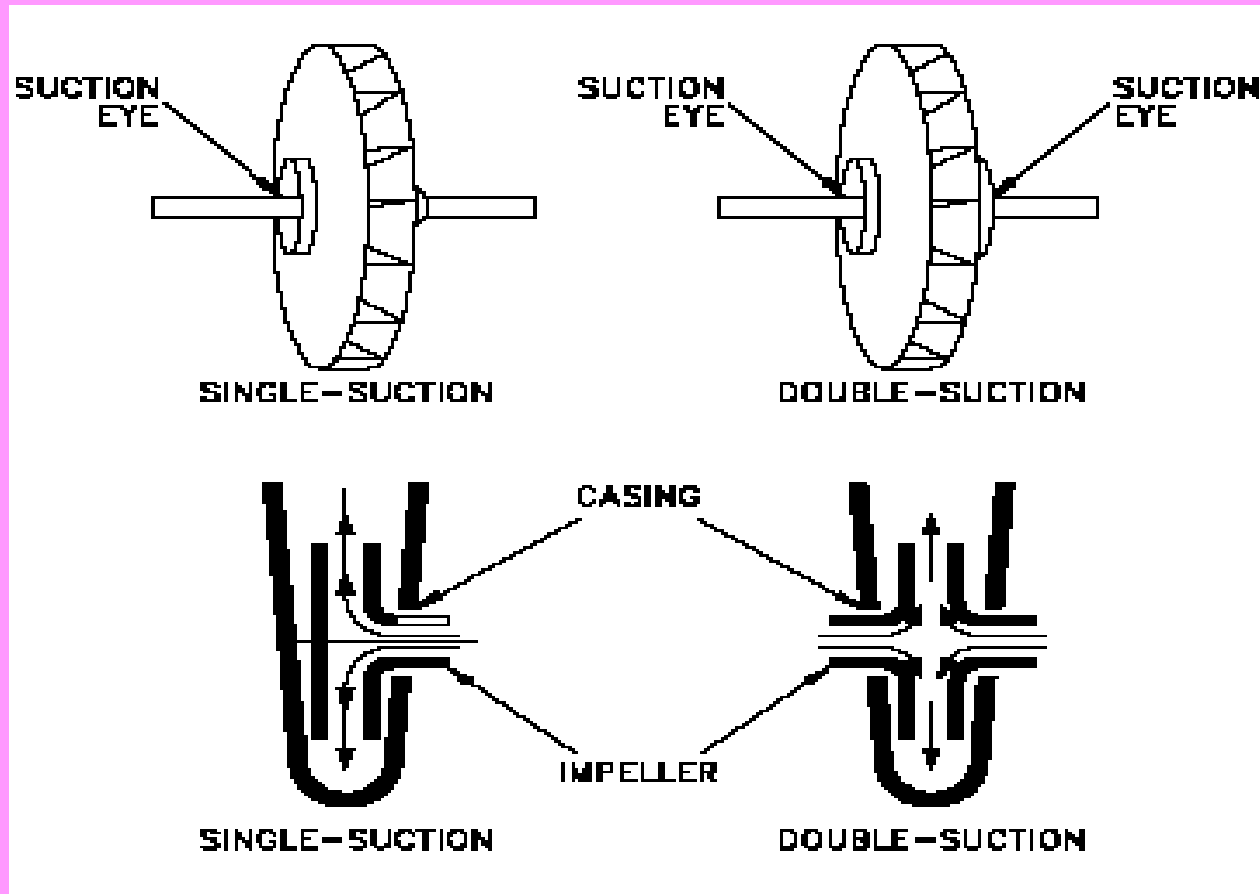



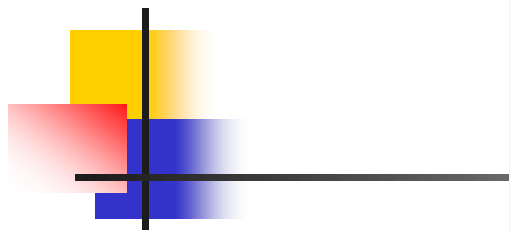

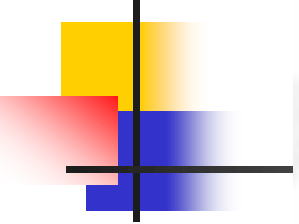

As a special feature the spacer model is equipped with a coupling which is a combined distance and flexible coupling making it possible to remove the complete bearing housing with shaft, bearings, shaft seal, and impeller without dismantling or loosening the motor or piping.



# Centrifugal P/P- Double Entry

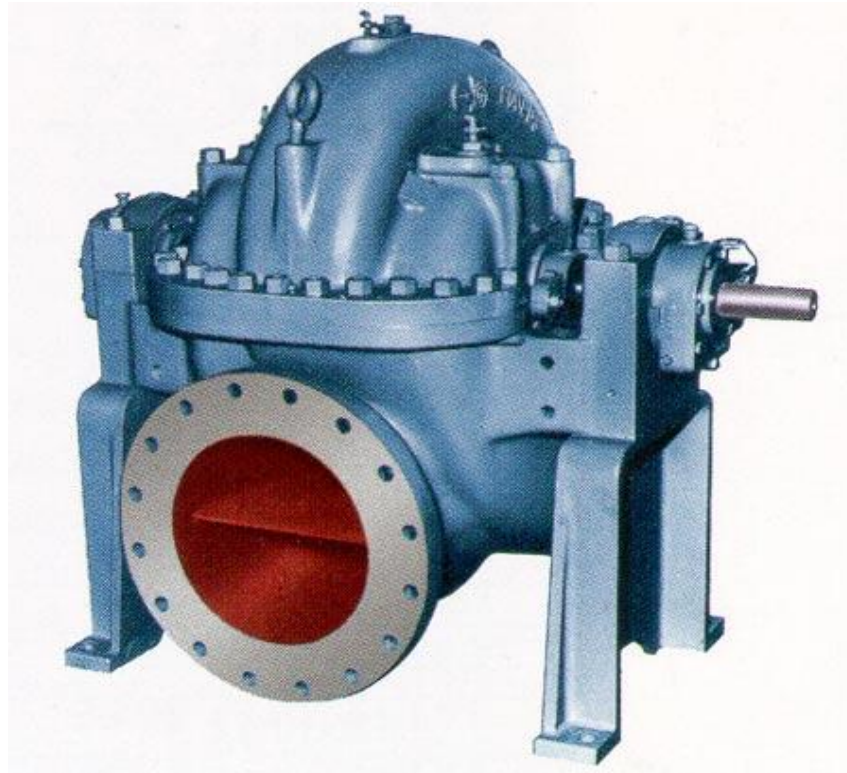

# Types of Centrifugal Pumps With Respect to the Construction of the Casing.

❖ **Volute**

❖ **Diffuser**

❖ **Regenerative**

# Volute Casing

❖ It is like a curved funnel increasing in area to the discharge port, which converts velocity energy into pressure energy. Also it helps to balance the hydraulic pressure on the shaft of the pump- occurs at the recommended capacity. Running at lower capacity can put lateral stress on pump shaft, increase wear-and-tear on the seals, bearings and on the shaft itself.

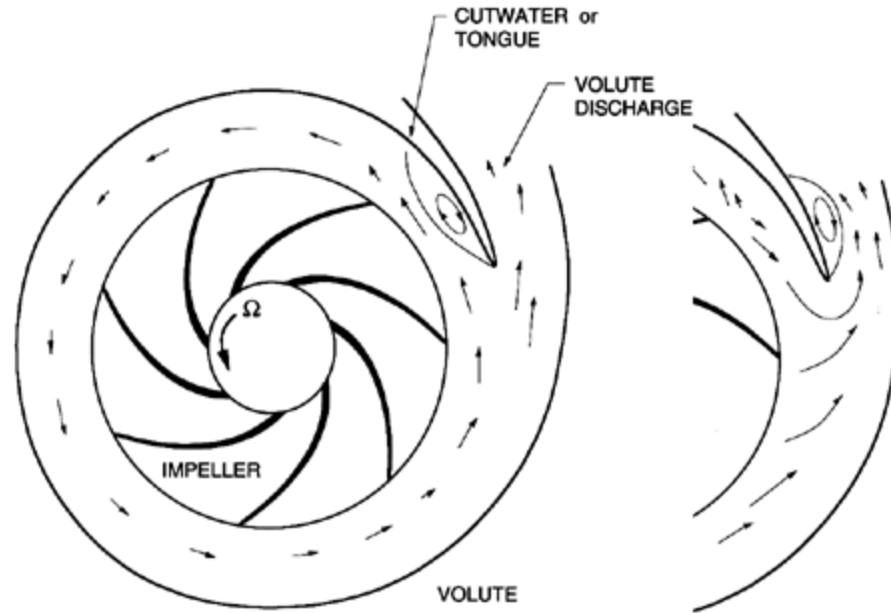
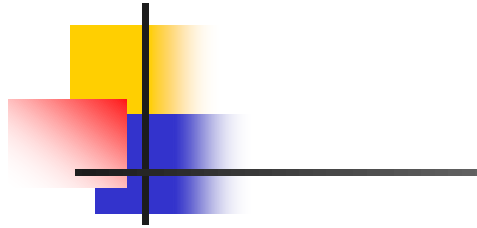

*Figure 4.12 Schematic of a centrifugal pump with a single, vaneless volute indicating the disturbed and separated flows which can occur in the volute below (left) and above (right) the design flow rate.*



# Double Volute Pump

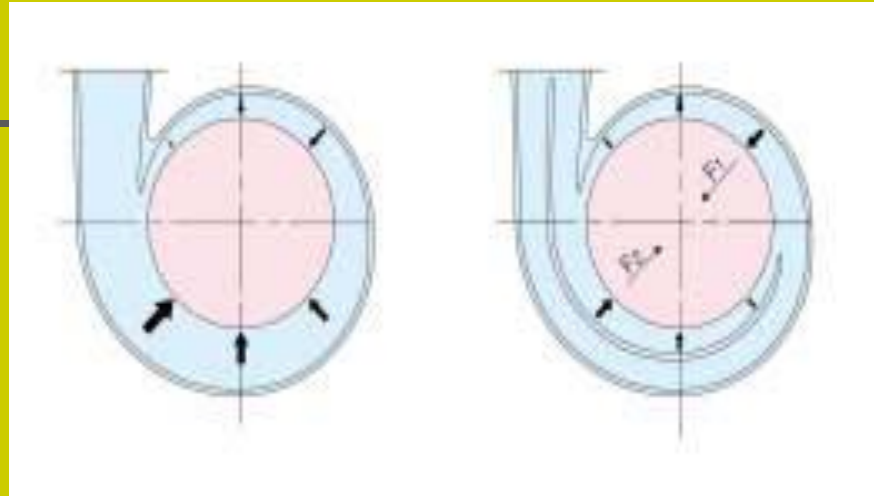

**Double volute minimizes radial thrust. While in a double volute pump, the pressures are not uniform at part-capacity operation, the resulting forces  $F_1$  and  $F_2$  for each 180° volute section oppose and essentially balance each other results in low shaft deflection at all operating points. Low deflection reduces packing wear, ring wear and bearing loading, which ultimately results in sustained efficiency and economy of operation.**

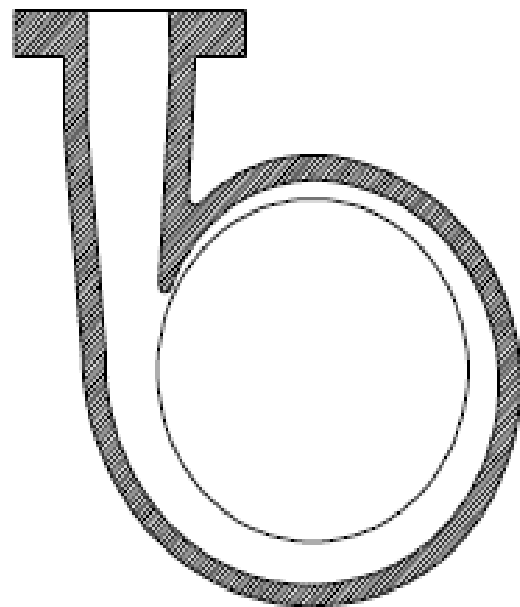
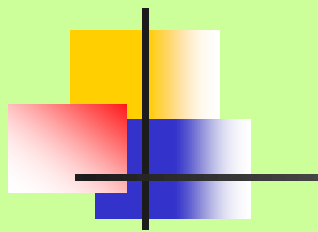

SINGLE

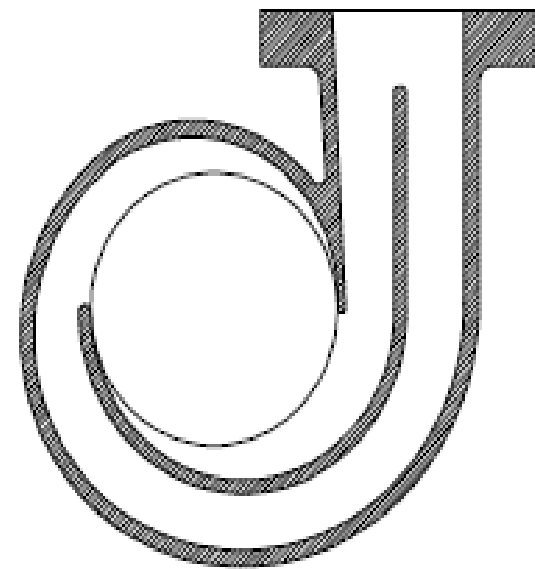

DOUBLE

Figure 2 Single and Double Volutes

# Diffuser or Circular Casing

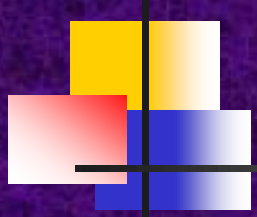

- It has stationary diffusion vanes, surrounding the impeller periphery that convert velocity energy into pressure energy.
- Conventionally the diffusers are applied to multistage pumps.

# Diffuser Casing

U.S. Patent

Aug. 26, 2003

Sheet 1 of 3

US 6,609,890 B2

FIG. 1  
(PRIOR ART)

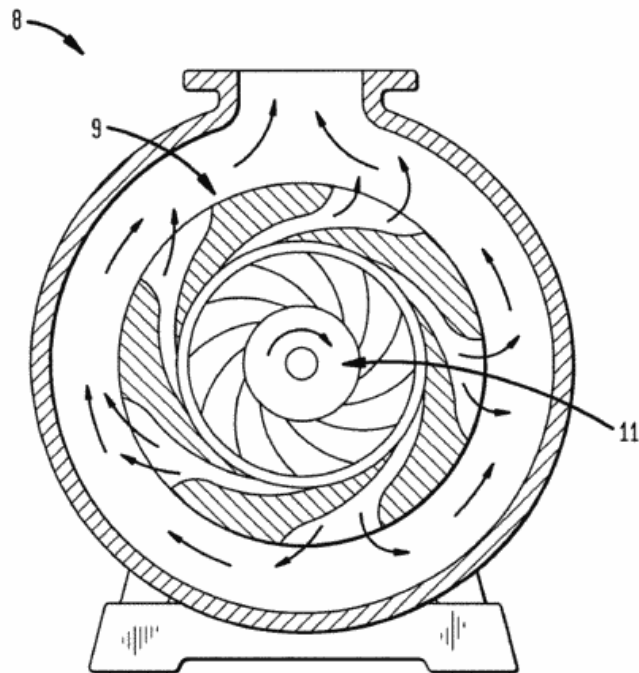

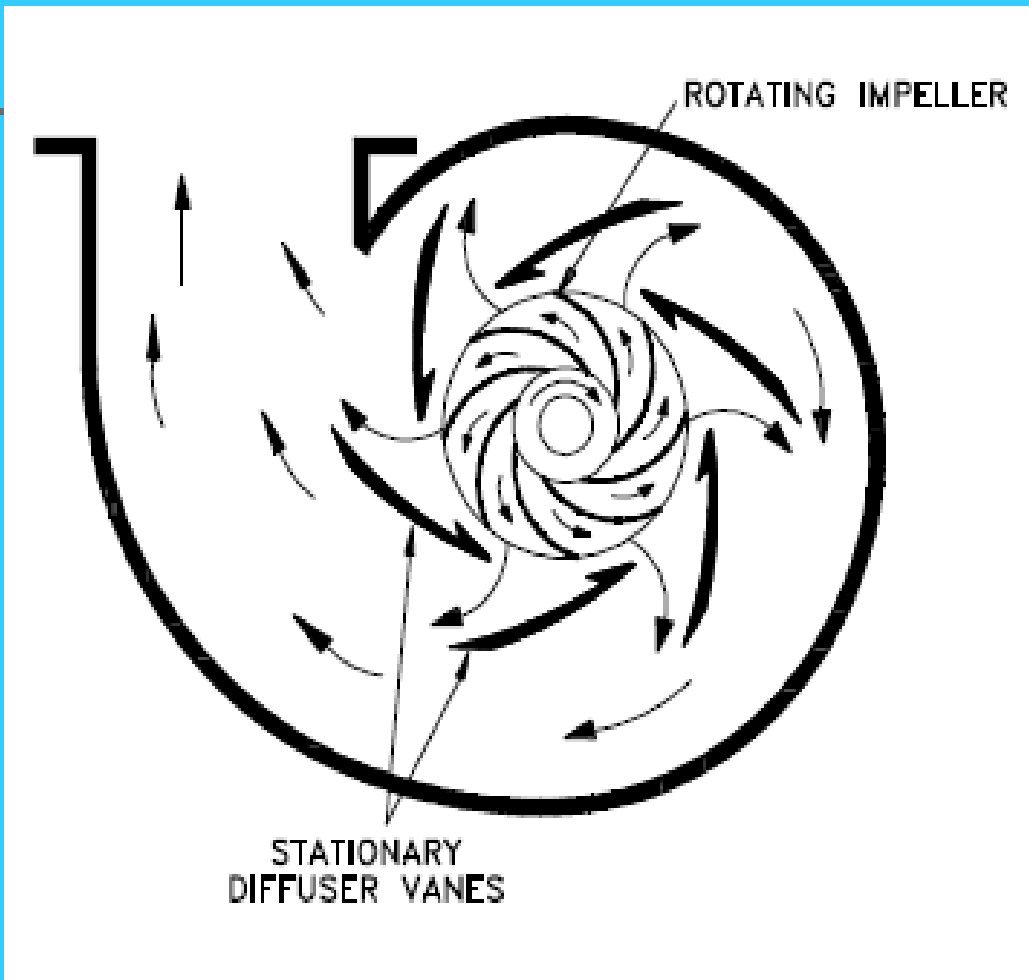
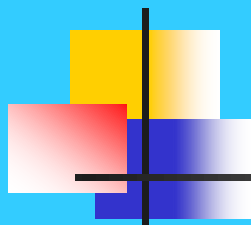
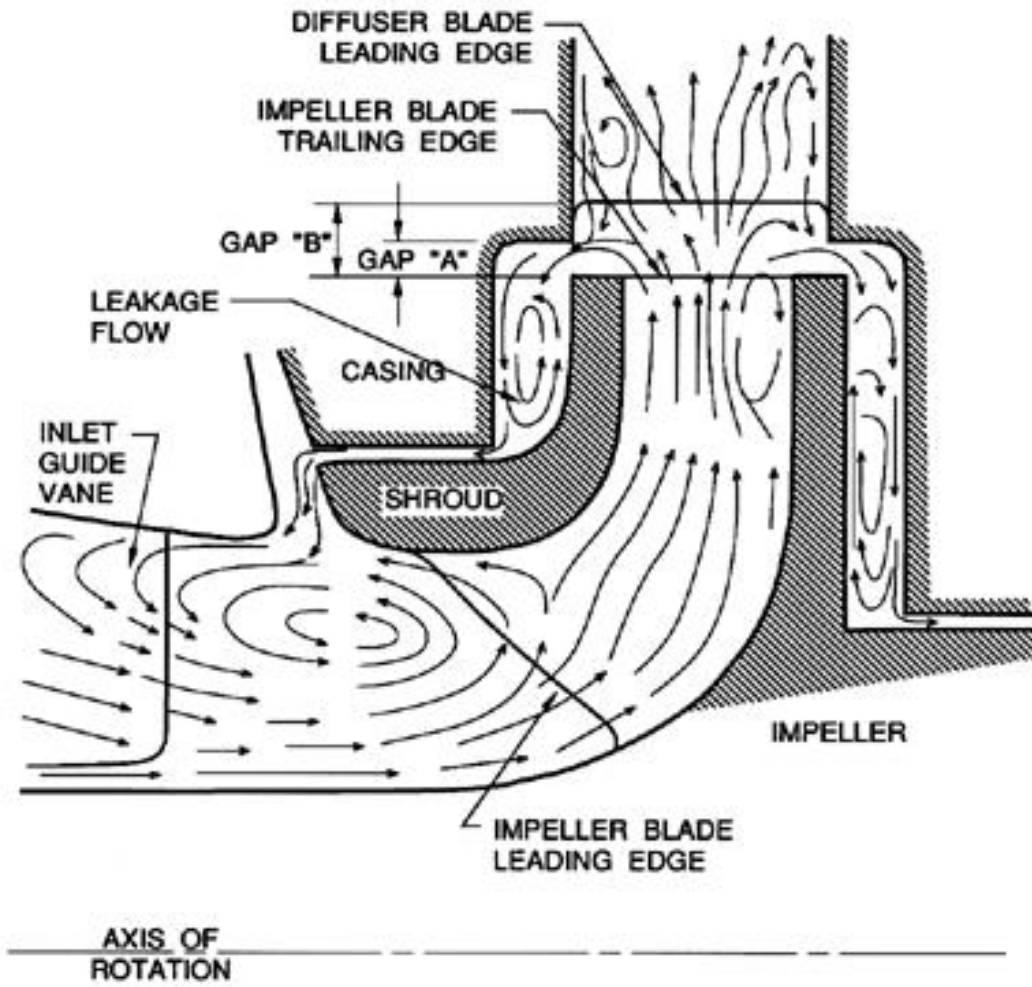
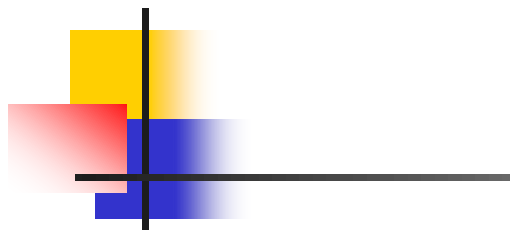

Figure 3 Centrifugal Pump Diffuser





# Regenerative(turbine Pump)

---

❖ **The impeller , which has very tight axial clearance and uses pump channel rings. Liquid entering the channel from the inlet is picked up immediately by the vanes on both sides of the impeller and pumped through the channel by shearing action. The process is repeated over and over with each pass imparting more energy until the liquid is discharged.**

# Turbine Pump

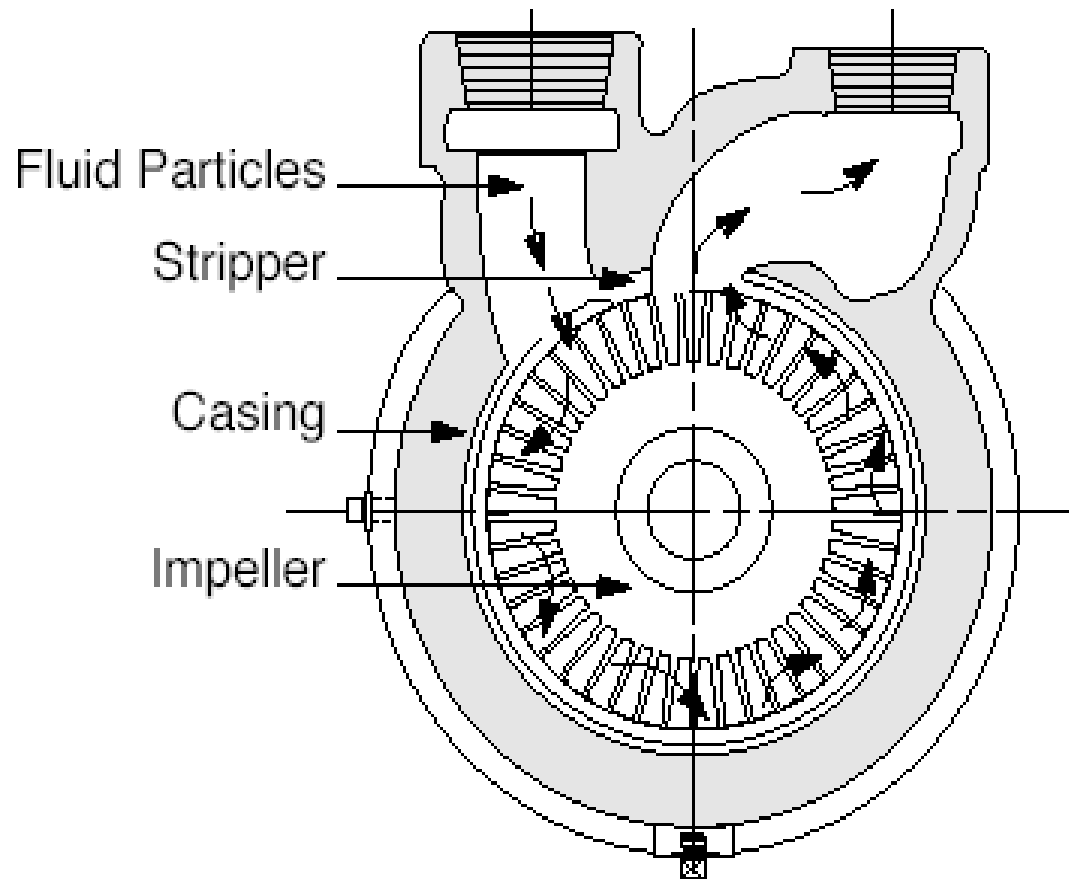
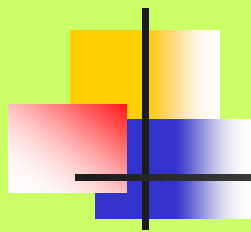



# Turbine Pump

## **TURBINE PUMPS (REGENERATIVE)**

- Turbine pumps obtain their name from the many vanes machined into the periphery of the rotating impeller. Heads over 900 feet are readily developed in a two-stage pump.
- The impeller, which has very tight axial clearance and uses pump channel rings, displays minimal recirculation losses. The channel rings provide a circular channel around the blades of the impeller from the inlet to the outlet.
- Liquid entering the channel from the inlet is picked up immediately by the vanes on both sides of the impeller and pumped through the channel by the shearing action. The process is repeated over and over with each pass imparting more energy until the liquid is discharged (Figure 7).

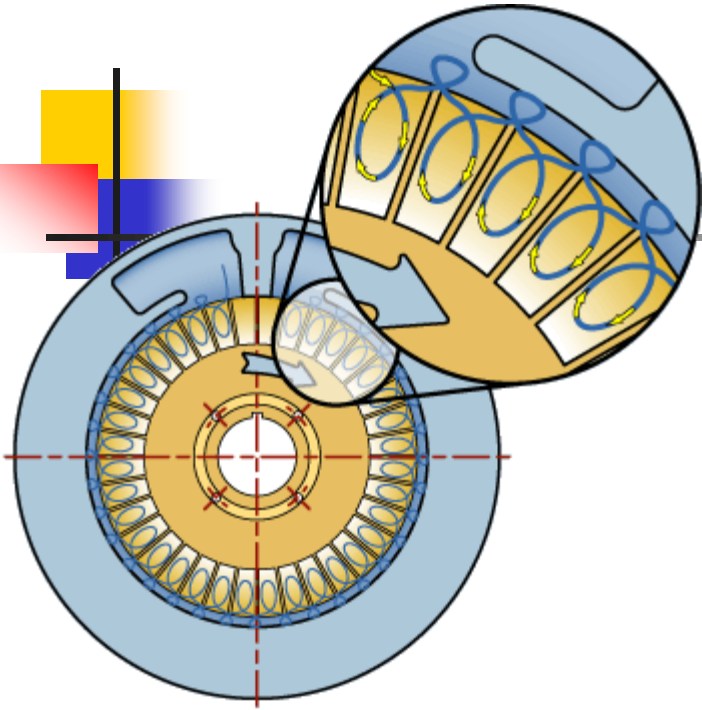

The primary difference between a centrifugal and a regenerative turbine pump is that fluid only travels through a centrifugal impeller once, while in a turbine, it takes many trips through the vanes. Referring to the cross-section diagram, the impeller vanes move within the flow-through area of the water channel passageway. Once the liquid enters the pump, it is directed into the vanes, which push the fluid forward and impart a centrifugal force outward to the impeller periphery. An orderly circulatory flow is therefore imposed by the impeller vane, which creates fluid velocity. Fluid velocity (or kinetic energy) is then available for conversion to flow and pressure depending on the external system's flow resistance as diagrammed by a system curve.

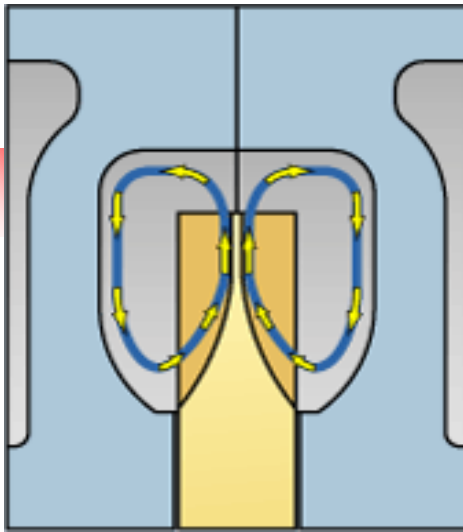

It is useful to note at this point, that in order to prevent the internal loss of the pressure building capability of an MTH regenerative turbine, close internal clearances are required. In many cases, depending on the size of the pump, impeller to casing clearances may be as little as one-thousandth of an inch on each side. Therefore, these pumps are suitable for use only on applications with clean fluids and systems. In some cases, a suction strainer can be used successfully to protect the pump.

Next, as the circulatory flow is imposed on the fluid and it reaches the fluid channel periphery, it is then redirected by the specially shaped fluid channels, around the side of the impeller, and back into the I.D. of the turbine impeller vanes, where the process begins again. This cycle occurs many times as the fluid passes through the pump. Each trip through the vanes generates more fluid velocity, which can then be converted into more pressure. The multiple cycles through the turbine vanes are called regeneration, hence the name regenerative turbine. The overall result of this process is a pump with pressure building capability ten or more times that of a centrifugal pump with the same impeller diameter and speed.

In some competitive designs, you will find that only a single-sided impeller is used. That design suffers from a thrust load in the direction of the motor that must be carried by the motor bearings. MTH turbines use a two-sided floating impeller design that builds pressure equally on both sides. This has the advantage of allowing the pump pressure to hydraulically self-center the impeller in the close clearance impeller cavity, while not burdening the motor bearings with excessive thrust loads.

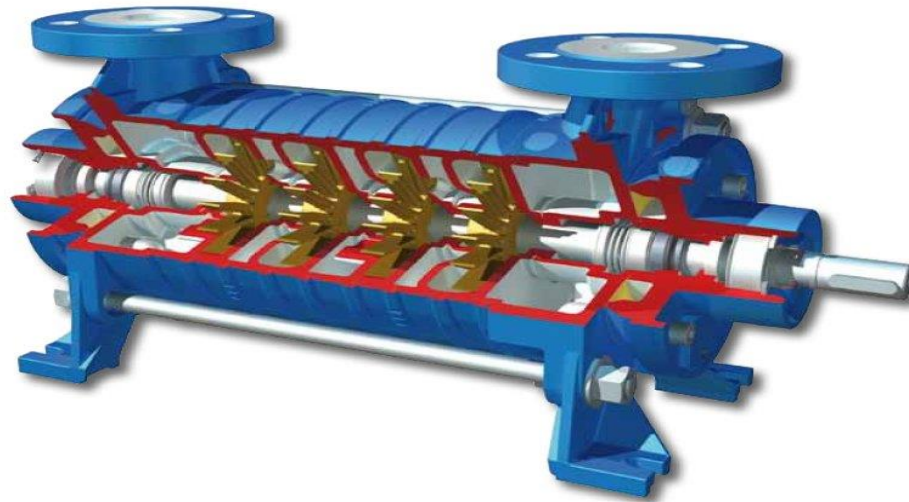

bare shaft version  
*versione ad asse nudo*



star shaped impeller  
*girante stellare*



vertical version  
*versione verticale*



coupling and baseplate version  
*versione con giunto e basamento*

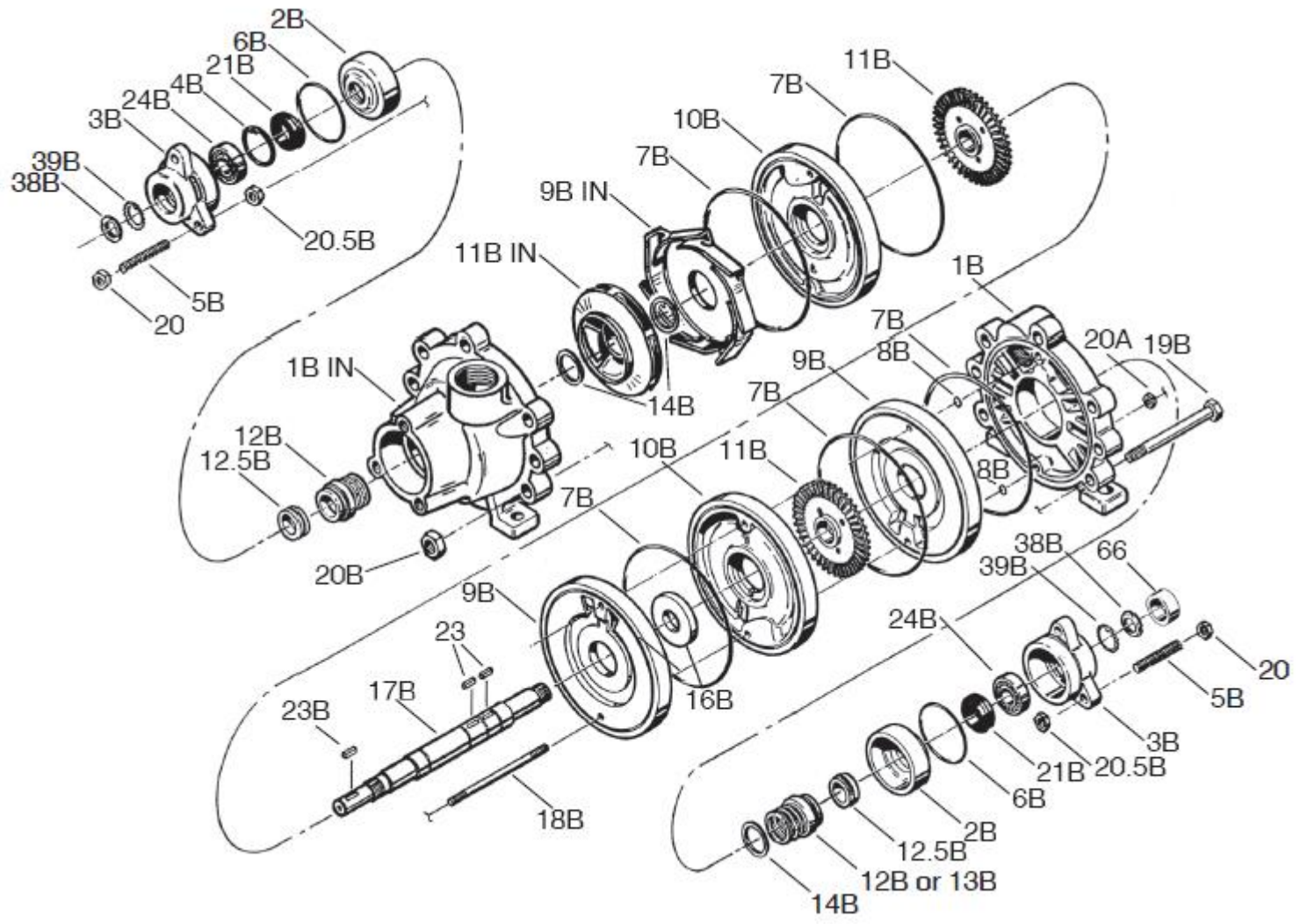

# Axially/Radially Split Casing

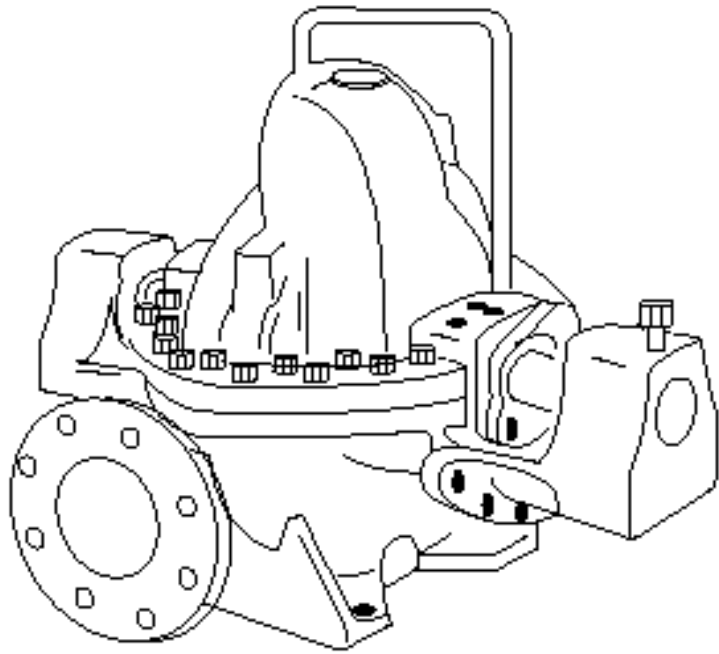
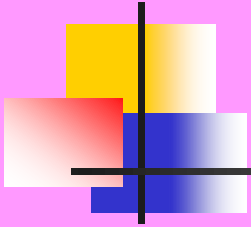

**FIGURE 29. Axially Split Casing**

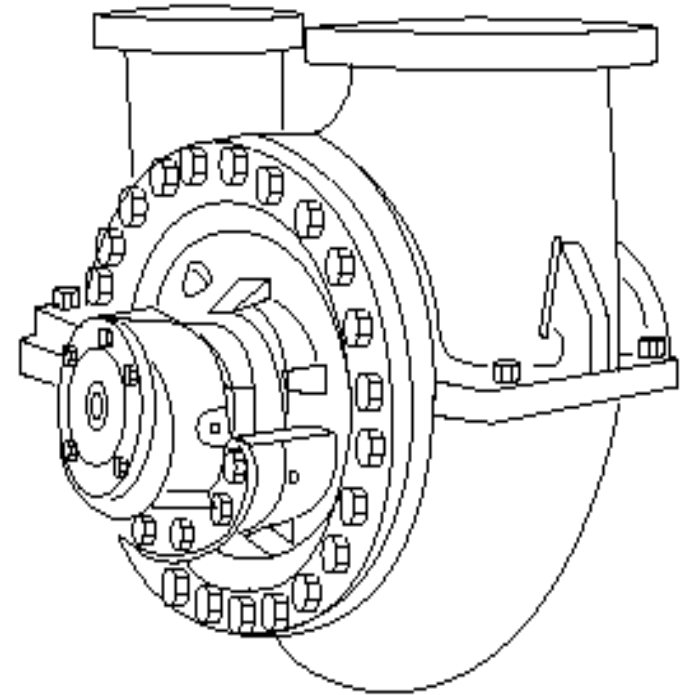

**FIGURE 30. Radially Split Casing**

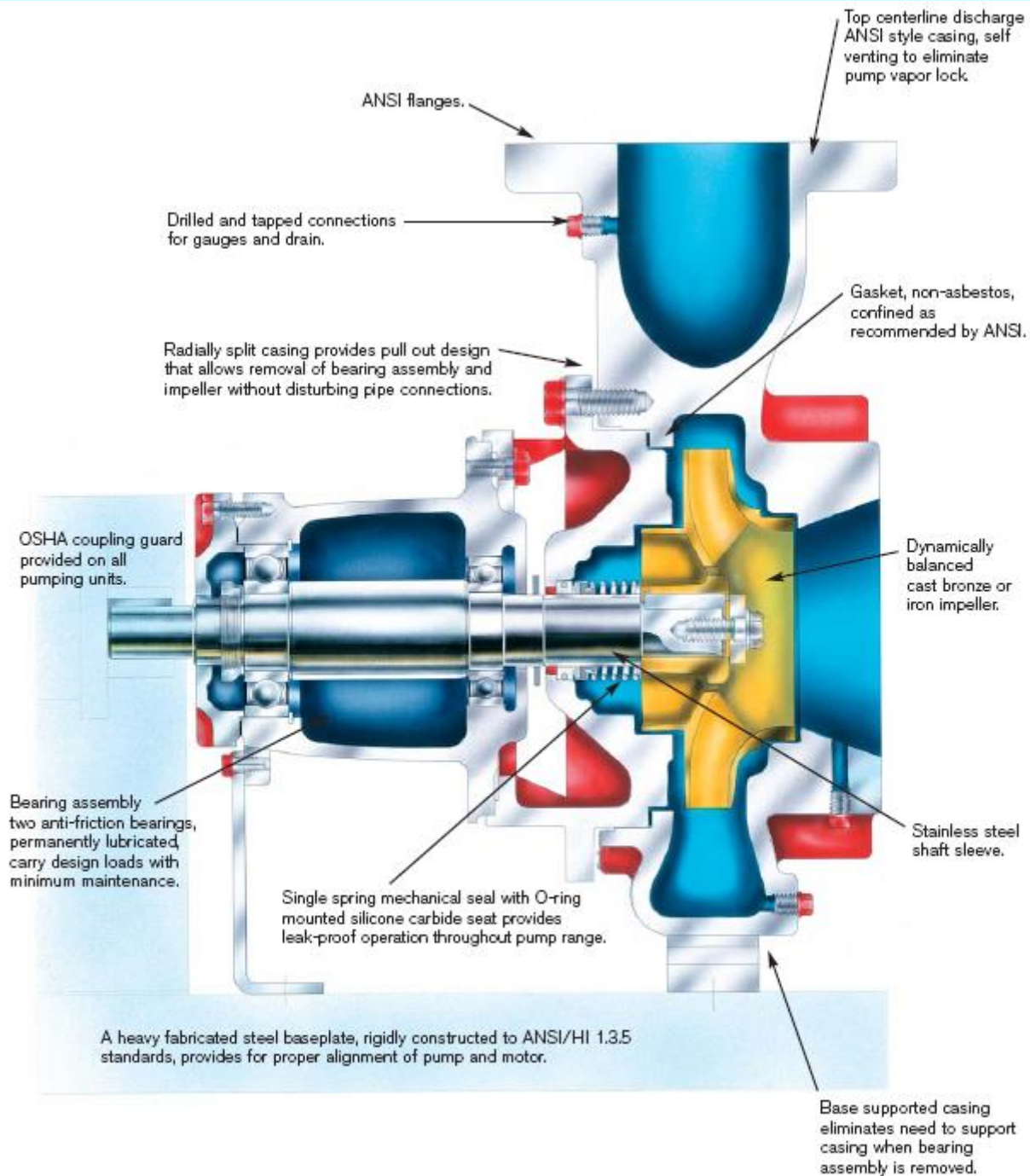

# Gland Packing- Stuffing Box

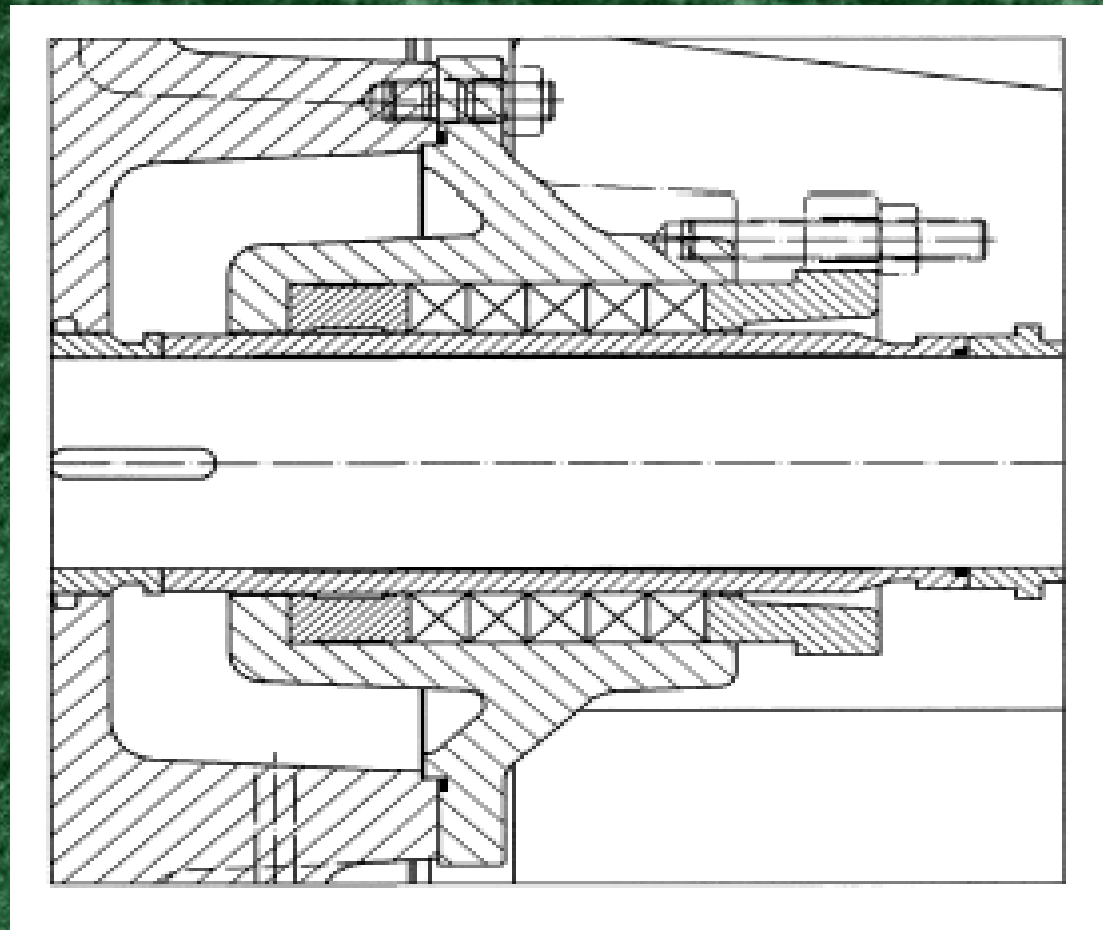



# Stuffing Box

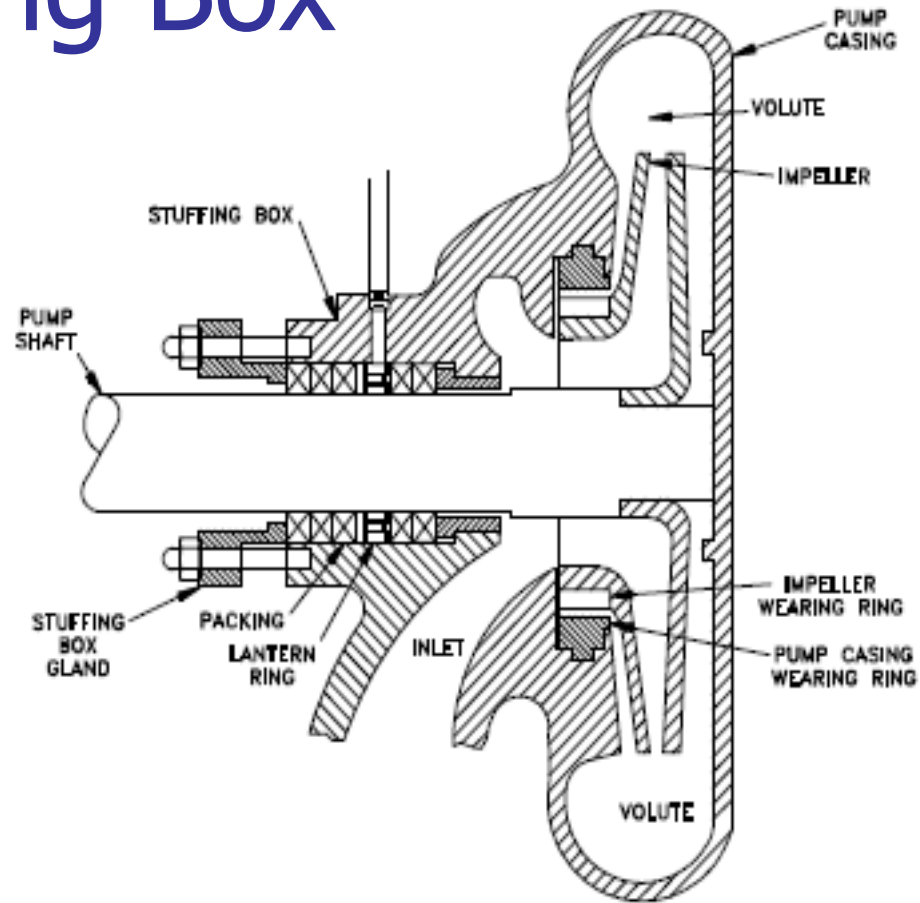
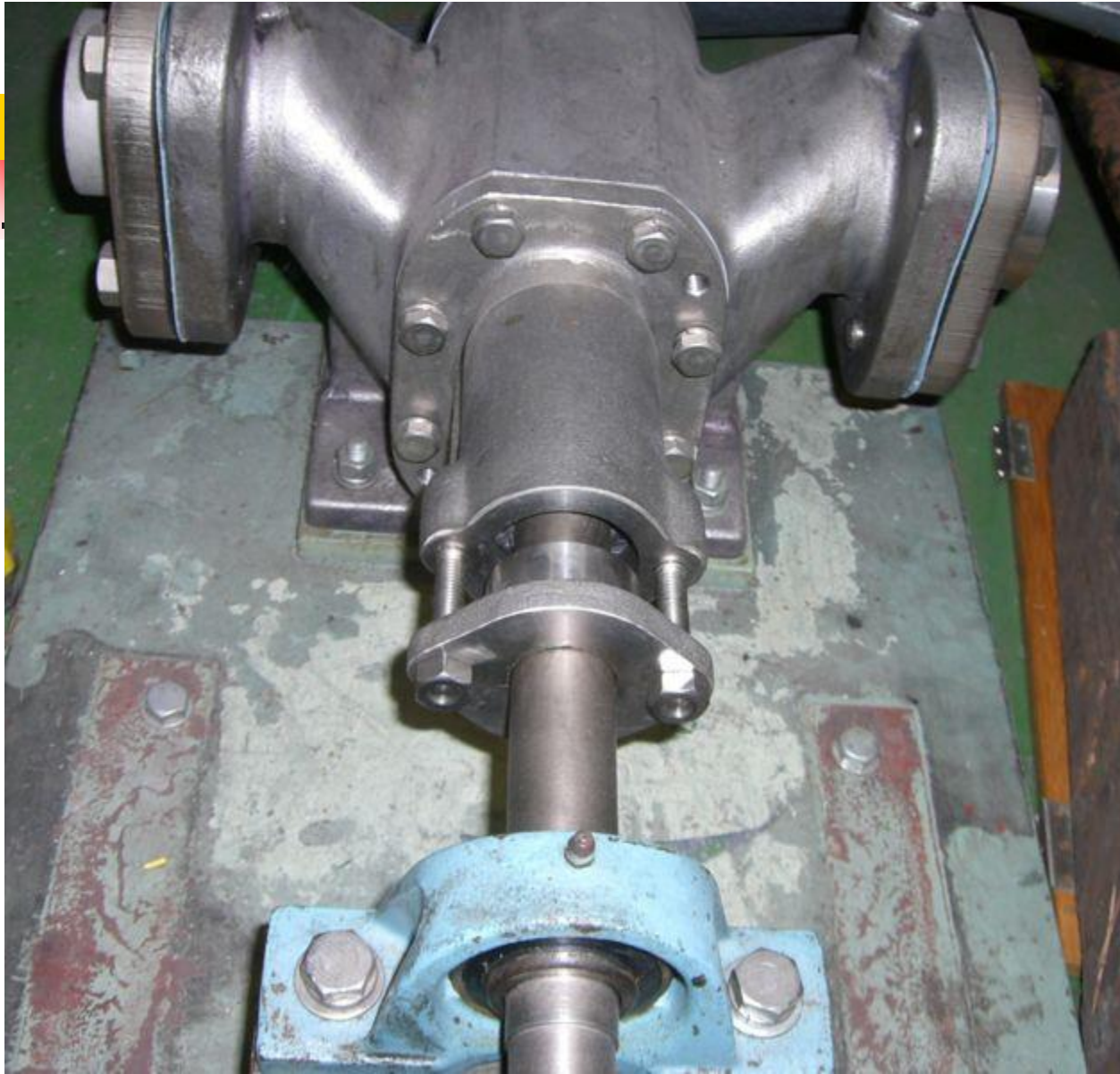
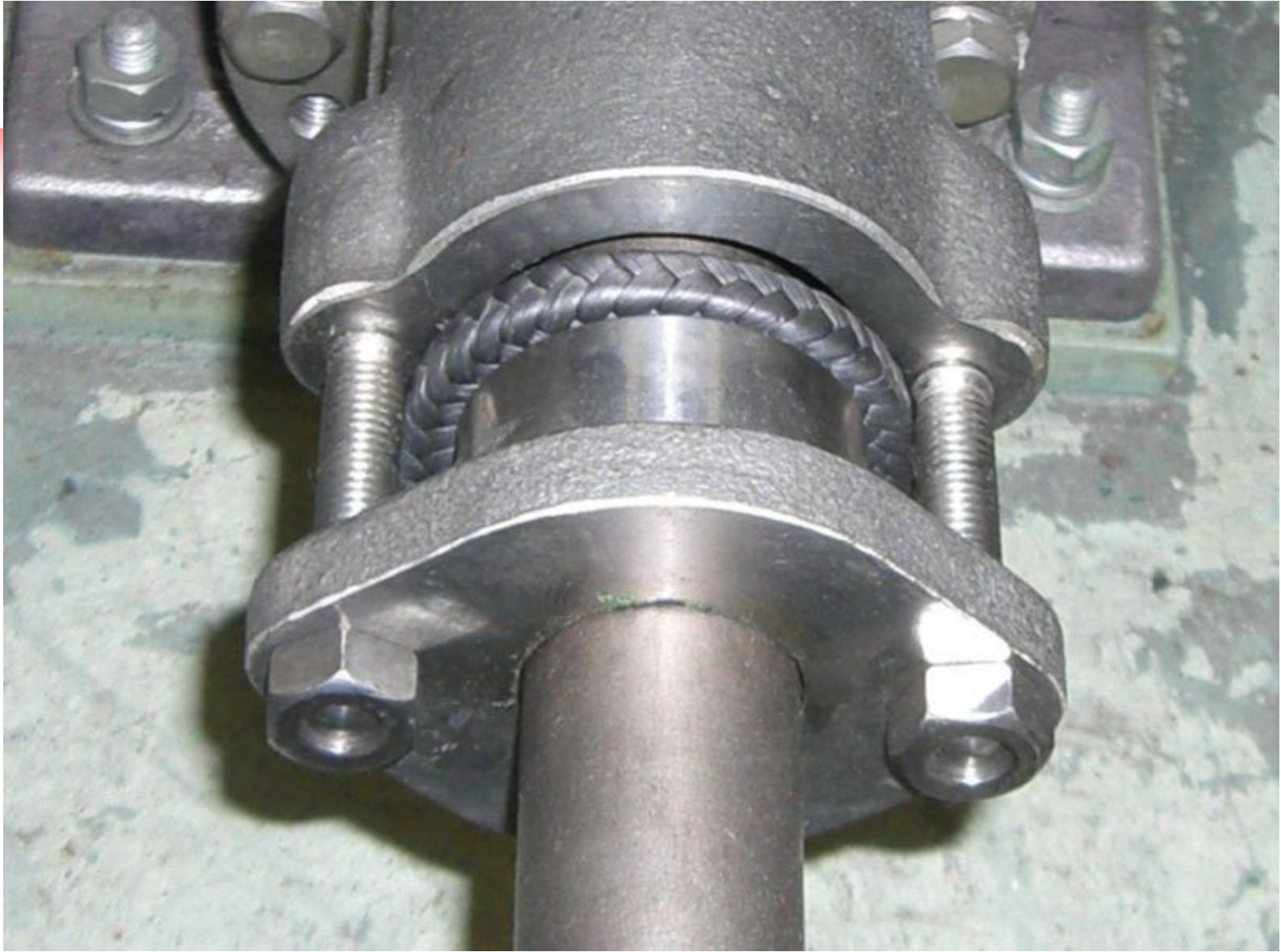
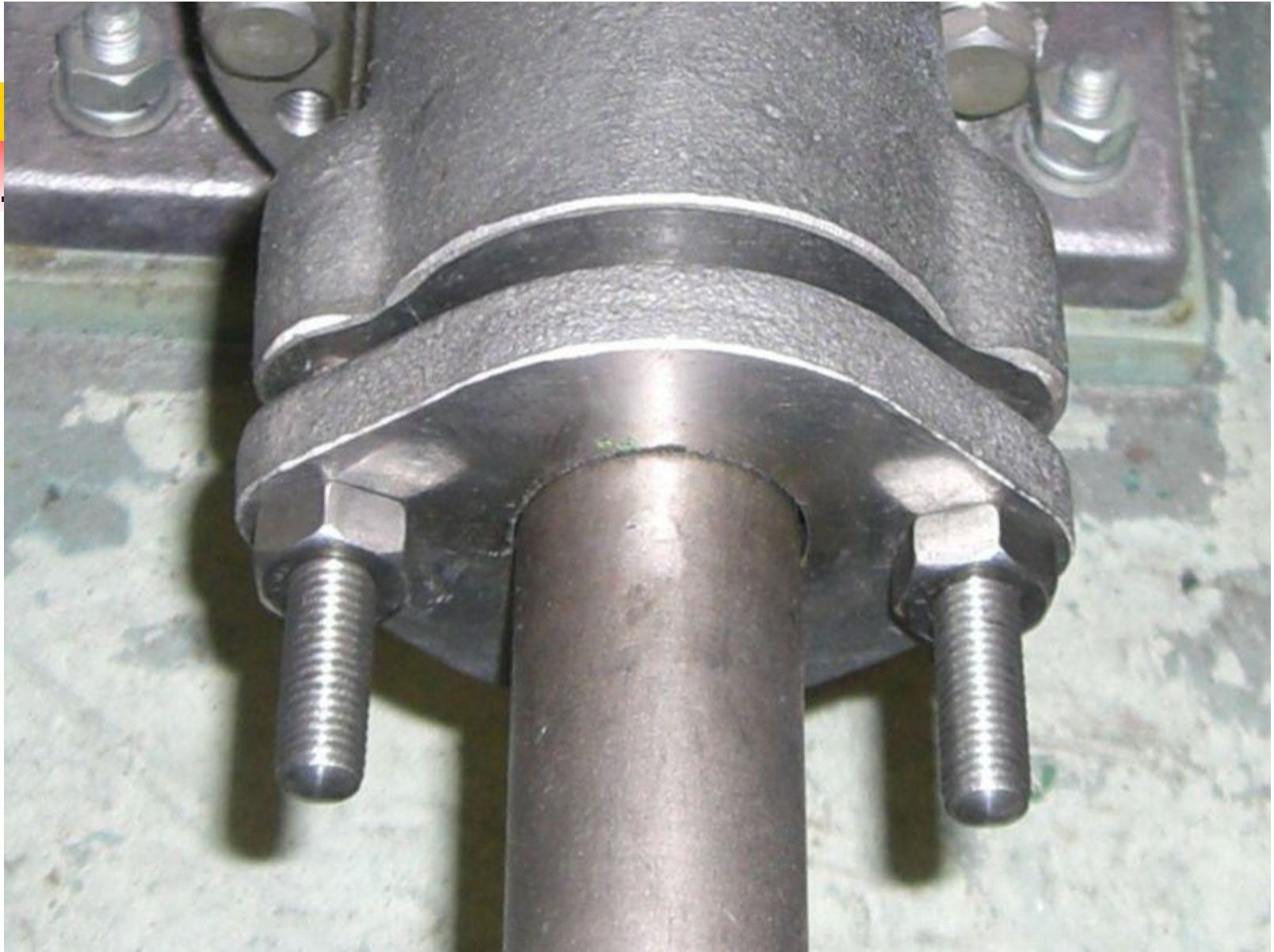

Figure 10 Centrifugal Pump Components









Using a packing puller to  
remove old packing

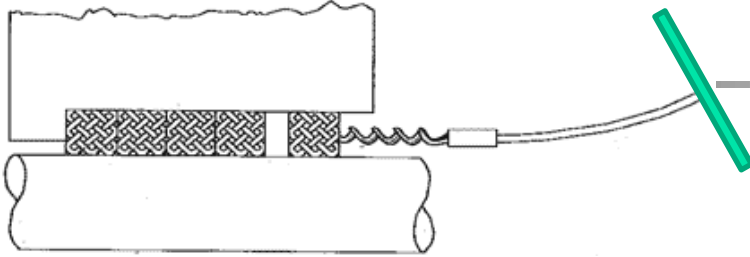

A split ring might be  
used to install the new  
packing.

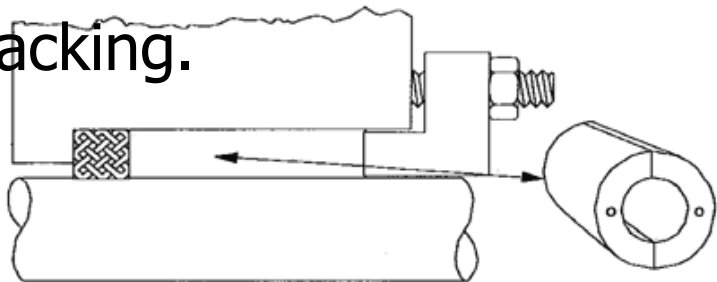

The gland follower  
should fit into the  
gland at least  $1/8''$   
but no more than  
 $3/16''$

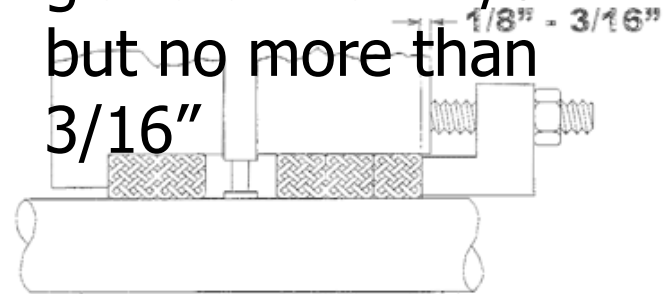

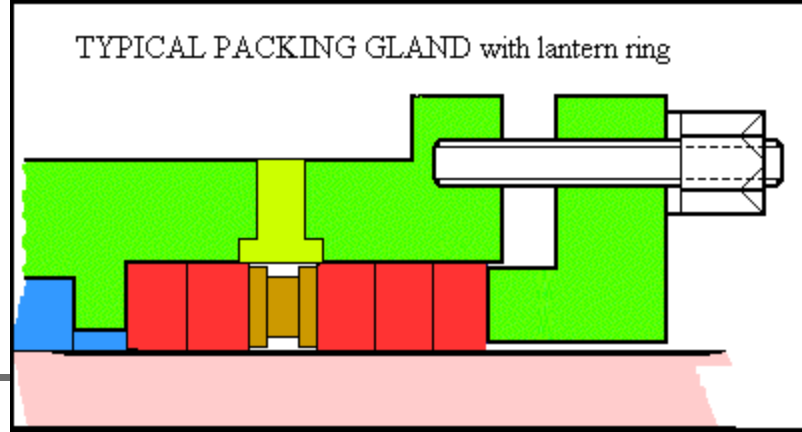

**Cut to size, the packing pieces are eased down the shaft to the neck ring. The cut ends are staggered to prevent leakage through them, the lantern ring is placed in position, the final three pieces of packing tamped in place by the gland plate and the work is done.**

**The next stage is to adjust the gland to ensure that it leaks. The leakage rate is controlled by the pressure exerted by the gland plate on the end of the packing set and the leak is allowed to develop along the shaft / packing interface to provide a cooling medium, removing the friction heat generated by the rotation of the shaft in the packing set. Two further things happen here. The grease in the packing melts slightly and is washed away by the flow of liquid along the shaft, and wear at the surface of the packing begins. A cycle is beginning which leads to the destruction of the packed gland as an effective leakage control device. The packing volume decreases as the lubricant is lost. Inevitably this causes the leakage rate to increase. As the rate increases more material is lost until the gland is tightened to reduce the leak to a minimum.**

TYPICAL PACKING GLAND with lantern ring

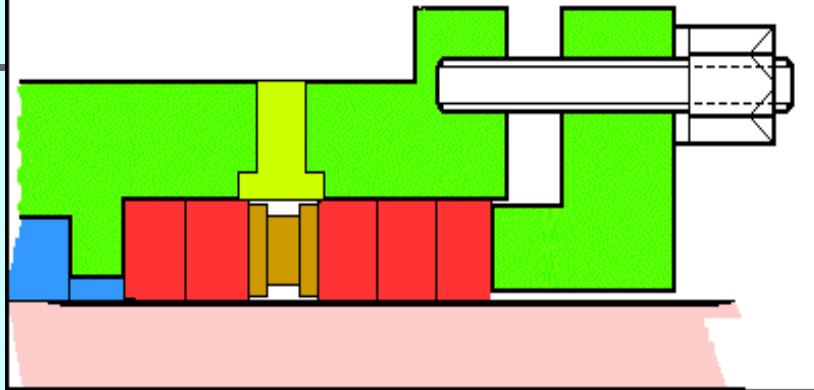

TYPICAL DAMAGE ON A WORN SHAFT SLEEVE

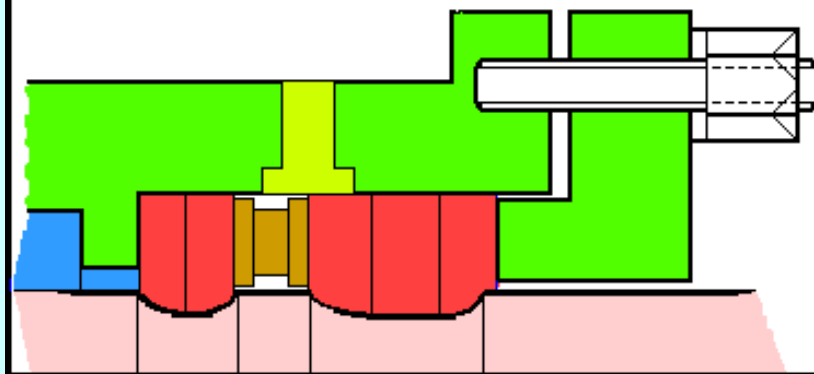



# Pump – Lantern Ring

## Lantern Ring

It is often desirable to lubricate and cool the packing with external water or oil. When water is used it is called seal water<sup>17</sup> or flush water. The seal water is distributed into the stuffing box through the lantern ring. The lantern ring is commonly a brass ring with holes that allow the water to easily pass.

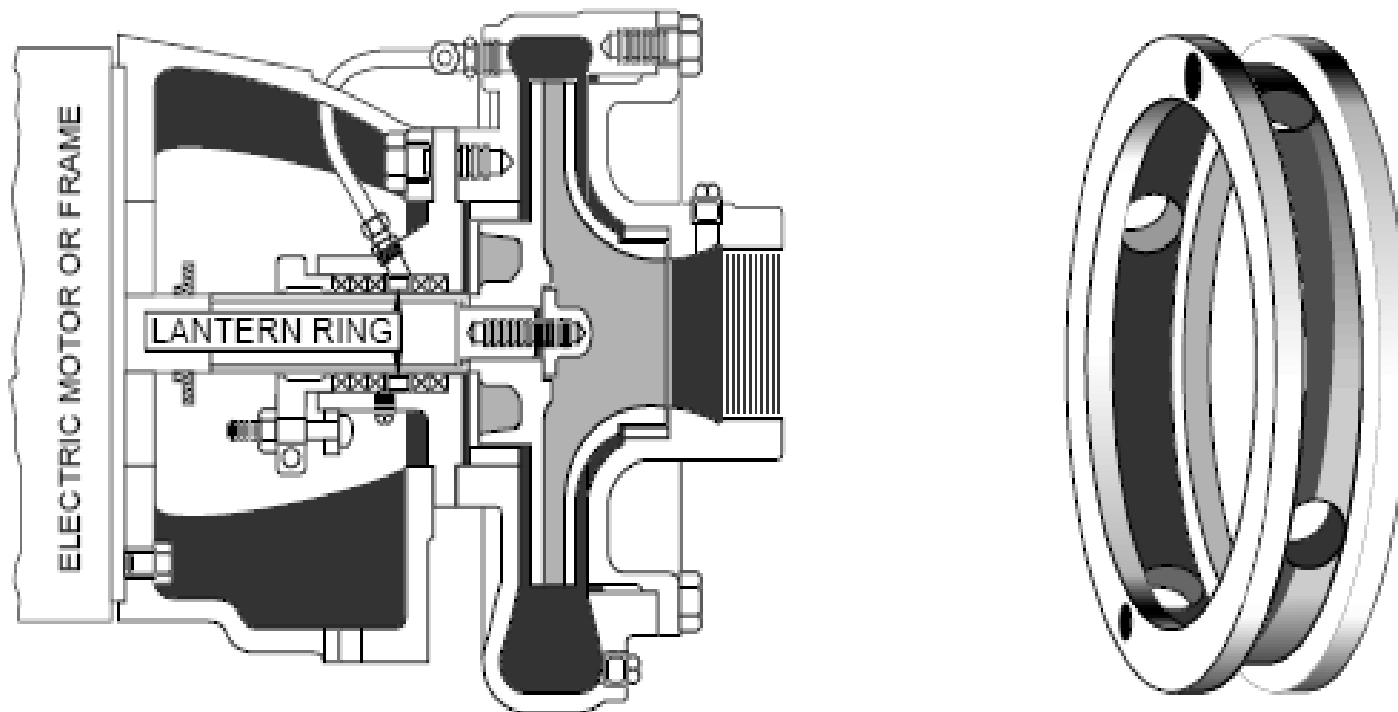

# Impeller, wear rings



IMPELLER  
WITH IMPELLER  
WEARING RING



IMPELLER AND  
CASING WEARING  
RING

# Pump wear ring

## Wear Rings

With closed impellers the impeller fits very close to the case. As a result, the case is worn by material passing from the high pressure side of the impeller to the low pressure side. To protect the case brass or stainless steel wear rings are inserted into the case.

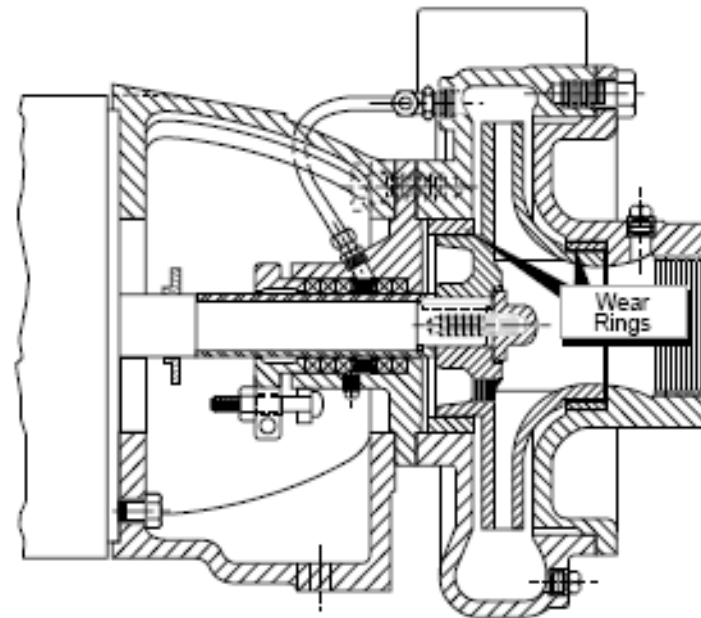



# Pump – shaft sleeve

---

## Shaft Sleeve

To protect the shaft from damage due to the packing, a shaft sleeve is installed. A shaft sleeve is a brass or stainless steel sleeve that fits tightly over the shaft.

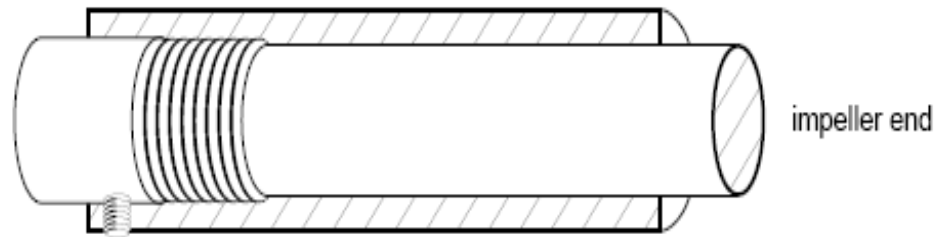

# Pump – Mechanical Seal

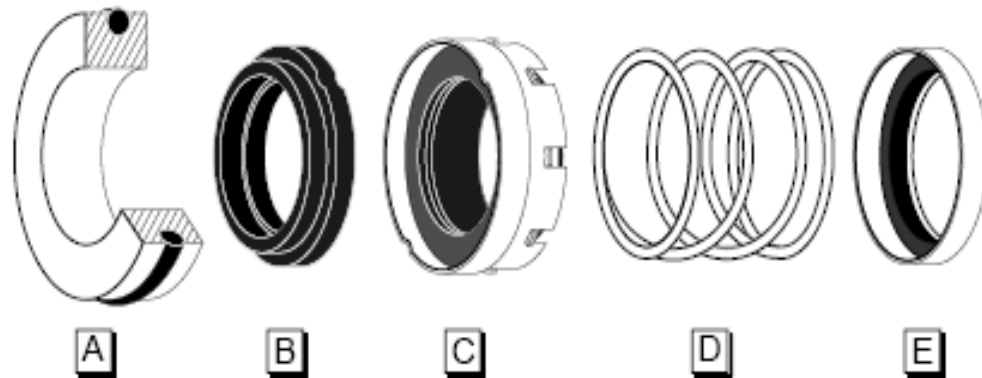
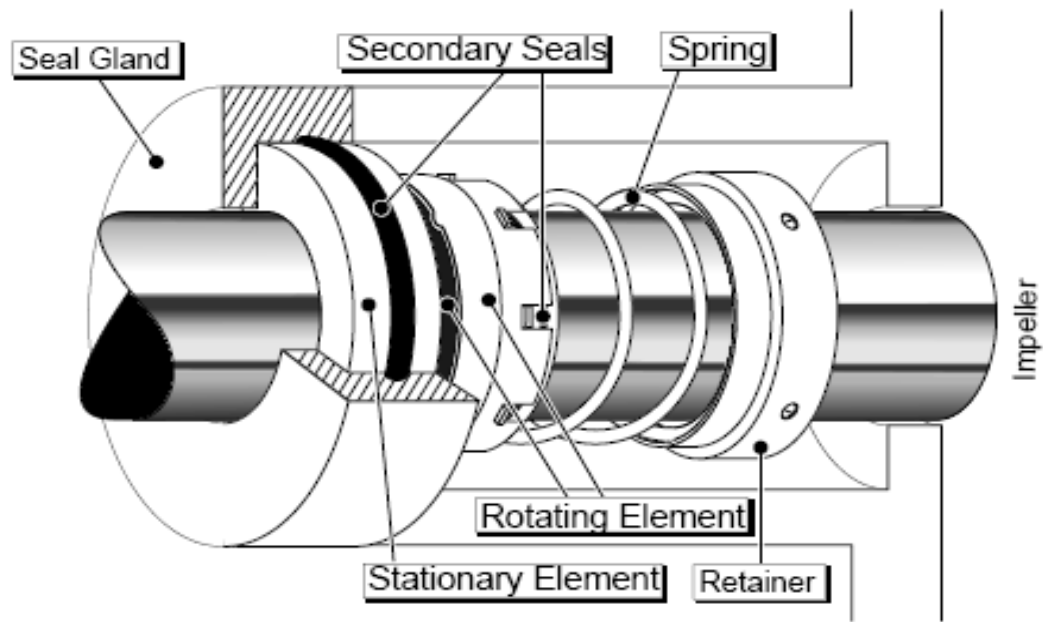

37

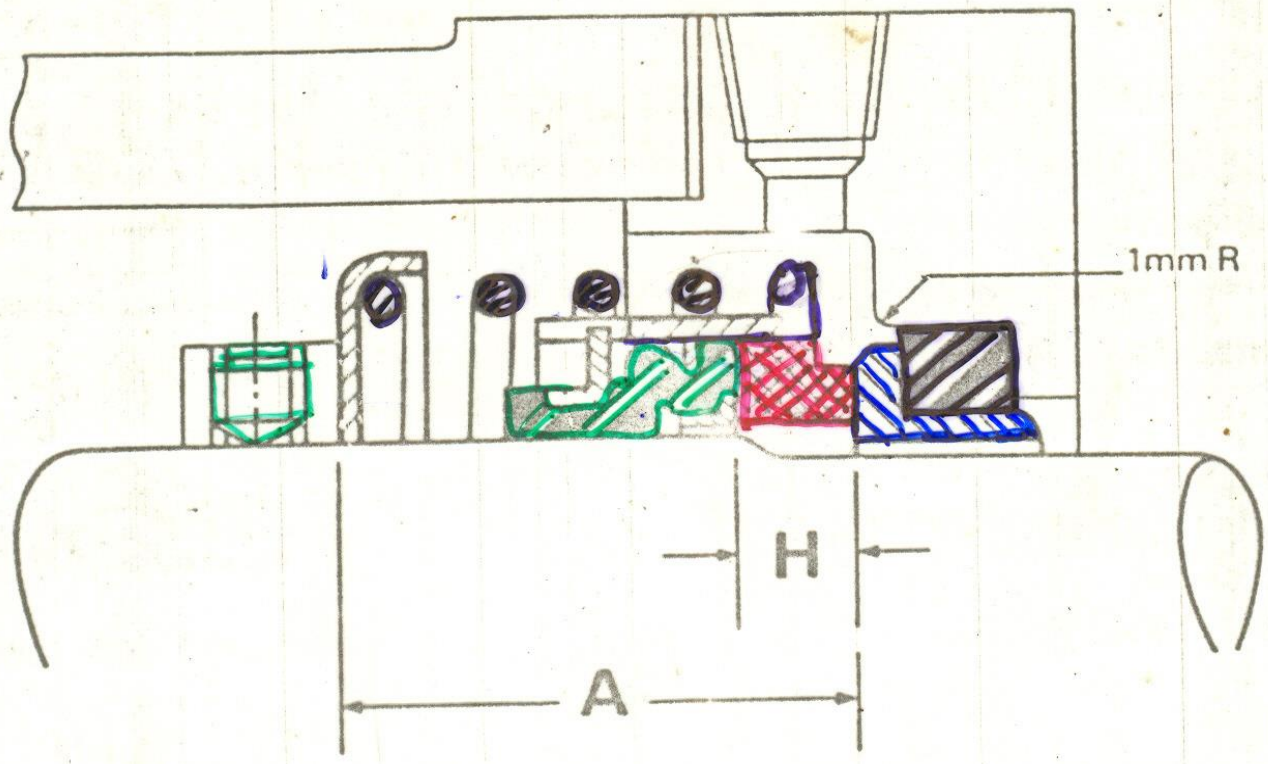

18 431

IRON A/S  
GENERATORVEJ 10  
HERLEV - DENMARK

CRANE  
TYPE 2

MECH. SEAL — GLEITRINGDICHTUNG — GARNITURE MEC. — MEK. AKSELTÆT.

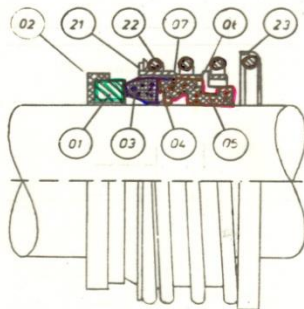

Pos. no.	MATERIALS
01	CERAMIC
02 05	SYNT RUBBER
03	KUL CARBON GREPHIT
04 06 07 21 22 23	RUSTFRIT STÅL STAINLESS STEEL RUSTFREI STAHL



02

Sæde  
Seat  
Sitz  
Siège



01

Sædering  
Seat Ring  
Sitzring  
Anneau de siége



03

Glidering  
Face  
Gletring  
Surface



04

L-Ring  
Ferrule  
L-Ring  
Anneau de protection



05

Bælg  
Bellows  
Fattenbalg  
Soufflets



06

Medbringer  
Drive Ring  
Mitnahmering  
Anneau d'entrainement



07

Trykring  
Thrust Ring  
Druckring  
Anneau de pression

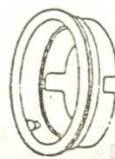

21

Medbringer  
bøsning  
Drive sleeve  
Mitnahme-  
hülse  
Douille



23

Fjederstyr  
Adapter  
Federteller

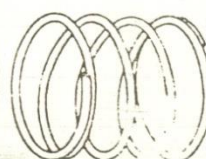

22

Fjeder  
Spring  
Feder  
Ressort

# Cavitation

## Steps in Cavitation

Formation of bubbles inside the liquid



Growth of bubbles



Collapse of bubbles



***Cavitation***

*Fig. 2*



# SUCTION CHARACTERISTICS

## CAVITATION, NPSH

*Basically, if there is not enough pressure –  
liquid boils!*

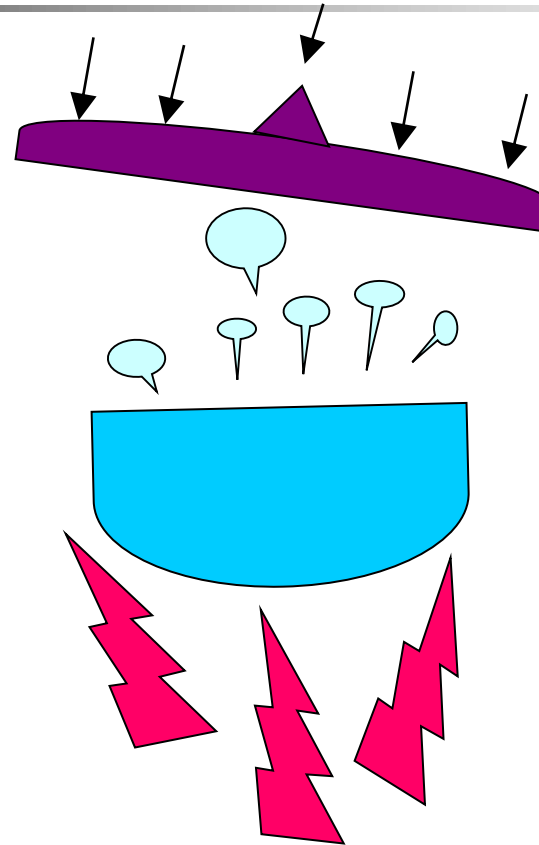



---

## **Suction Cavitation**

**Suction Cavitation occurs when the pump suction is under a low pressure/high vacuum condition where the liquid turns into a vapor at the eye of the pump impeller. This vapor is carried over to the discharge side of the pump where it no longer sees vacuum and is compressed back into a liquid by the discharge pressure. This imploding action occurs violently and attacks the face of the impeller. An impeller that has been operating under a suction cavitation condition has large chunks of material removed from its face causing premature failure of the pump.**

# Impeller inlet – blades cavitation on a suction side

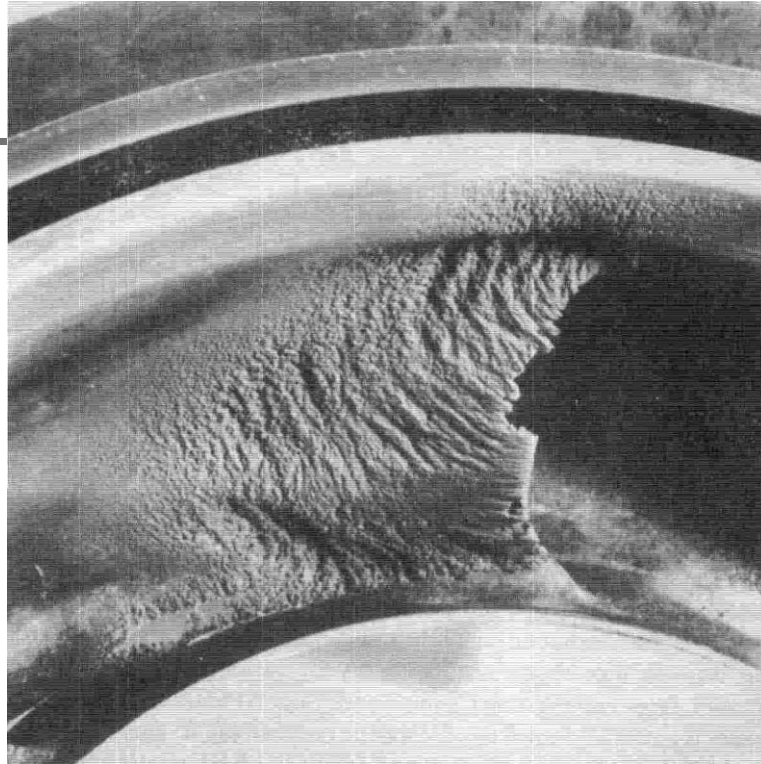

*As bubbles flow from low pressure to higher, they implode against metal surfaces. These micro-hammer-like impacts erode the material, creating cavities – thus "cavitation"*

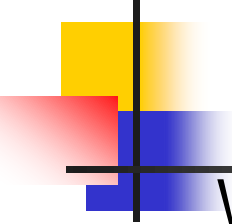

While pumping liquids containing dissolved gases, if the load static pressure should fall below the gas release pressure, then the gas will come out of solution forming gas bubbles. For air dissolved in water at 20°C this occurs at an absolute pressure of about 250mbar. Similarly if the pressure should drop to the liquid vapour pressure, then the liquid will start to vaporise or boil. For water the vapour pressure at various temperatures is shown in the table below.

Temperature °C	0	10	20	40	60	80	100
Vapour pressure mbar abs	6.15	12.3	23.4	74	200	474	1015



# Centrifugal Pump – Operational Summary

---

- **THREE INDICATIONS IF A PUMP IS CAVITATING**
- **Noise.**
- **Fluctuating discharge pressure and flow.**
- **Fluctuating pump motor current.**

# Steps to Stop cavitation of a Pump

- ❖ **Increase pressure at the suction of the pump.**
- ❖ **Reduce the temperature of the liquid being pumped.**
- ❖ **Reduce head losses in the suction piping.**
- ❖ **Reduce the flow rate through the pump.**
- ❖ **Reduce the speed of the pump impeller.**

# Effects of cavitation.



---

- **Degraded pump performance.**
- **Metal gets corroded seen as small pittings.**
- **Audiable rattling or crackling sounds which can reach a pitch of dangerous vibrations.**
- **Damage to pump impeller, bearings, wear rings and seals.**

# Pump Operation - Facts

- ❖ To avoid pump cavitation, NPSH available must be greater than NPSH required.
- ❖ NPSH available is the difference between the pump suction pressure and the saturation pressure of the liquid being pumped.
- ❖ Cavitation is the process of the formation and subsequent collapse of vapor bubbles in a pump.
- ❖ Gas binding of a centrifugal pump is a condition where the pump casing is filled with gases or vapors to the point where the impeller is no longer able to contact enough fluid to function correctly.



# Pump Operation - Facts

- **Shut off head is the maximum head that can be developed by a centrifugal pump operating at a set speed.**
- **Pump run out is the maximum flow that can be developed by a centrifugal pump without damaging the pump.**
- **The greater the head against which a pump operates, the lower the flow rate through the pump.**
- **Centrifugal pumps are protected from run-out by placing orifice or throttle valve immediately downstream of the pump discharge and through proper piping system design.**
- **The centrifugal pump can be protected from dead-heading by providing a recirculation from the pump discharge back to the supply source of the pump.**

# Centrifugal Pump Operation - Facts

- ❖ Discharge Pressure – Minimum throughput when head is maximum.
- ❖ Power – Minimum power consumed when no flow and the discharge head is at the highest.
- ❖ Losses –
  - 1) Shock and eddy losses caused by impeller blade thickness and other mechanical considerations.
  - 2) Frictional losses due to fluid contact with the pump casing etc.
  - 3) Inlet and Impact losses.



# Characteristics of Variable Speed Centrifugal Pump.

---

- ❖ Head varies as the square of the speed.
- ❖ Capacity varies directly as the speed.
- ❖ Power varies as cube of the speed.



# Characteristics of Constant Speed Centrifugal Pump

---

- ❖ Head varies as square of the diameter.
- ❖ Capacity varies as the diameter.
- ❖ Power varies as the cube of the diameter.



# System Performance Curves

---

- System Performance Curve is a mapping of the head required to produce flow in a given system
- A system includes all the pipe, fittings and devices the fluid must flow through, and represents the friction loss the fluid experiences

H ↑

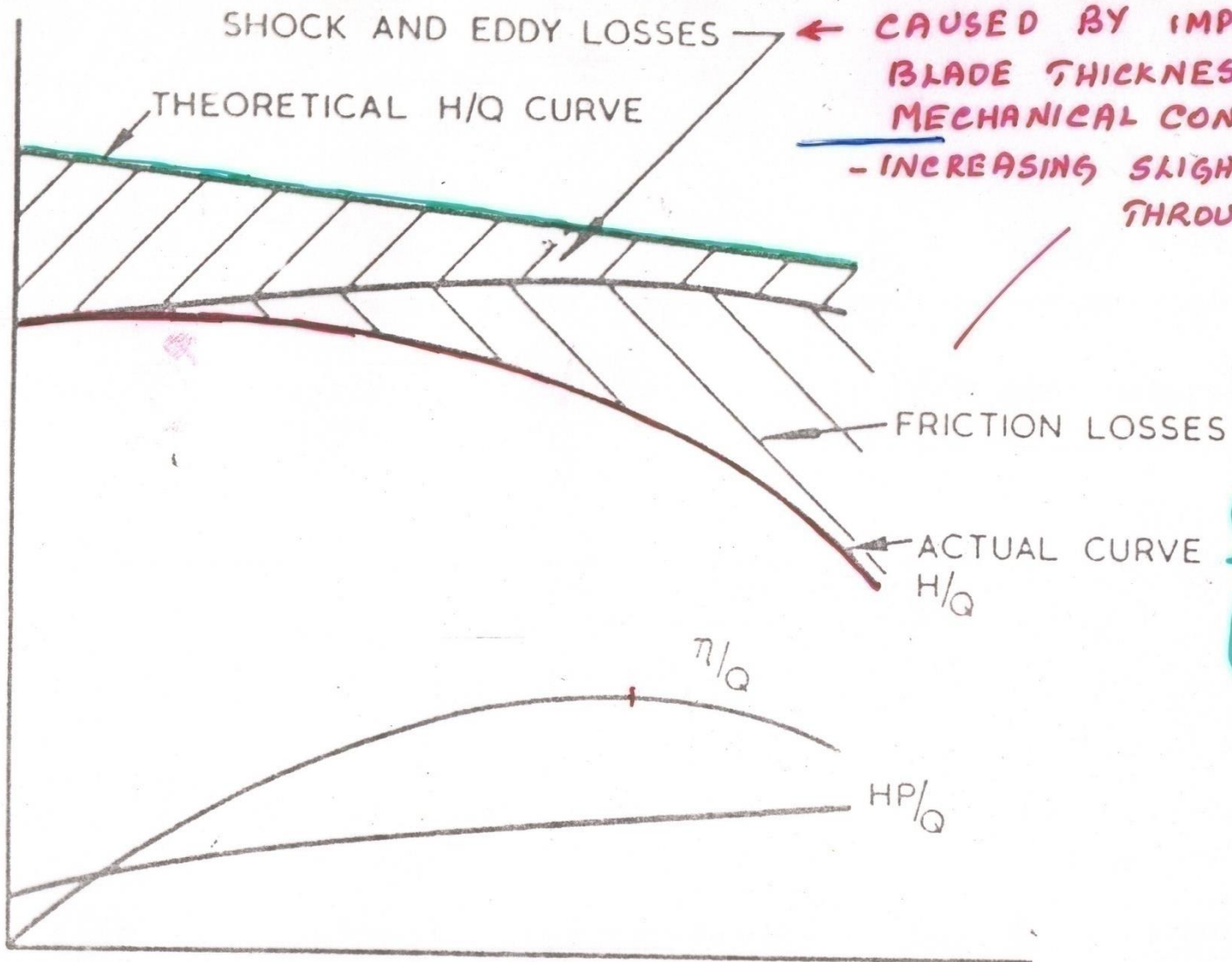

← CAUSED BY IMPELLER BLADE THICKNESS AND OTHER MECHANICAL CONSIDERATIONS - INCREASING SLIGHTLY WITH THROUGHPUT

{ VARIES WITH THE DESIGN & FEATURES OF A PARTICULAR PUMP

Q →

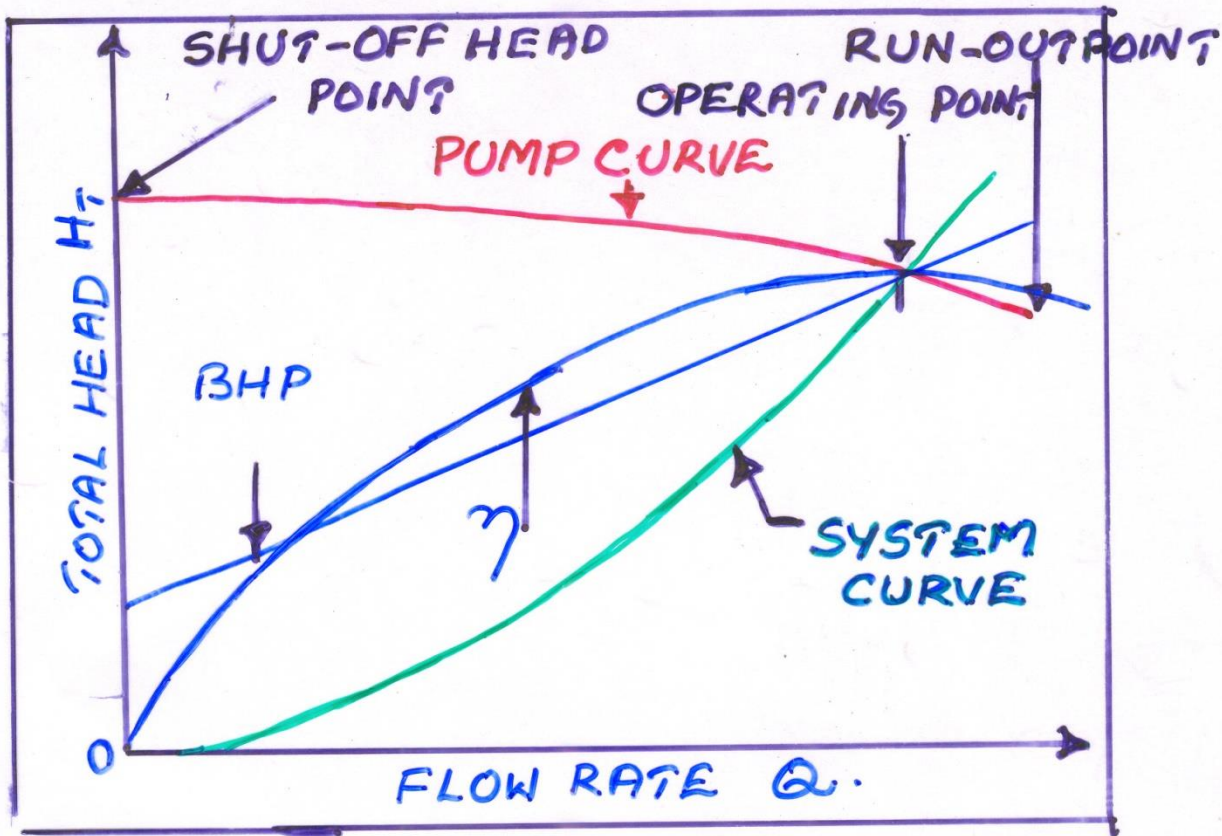

TYPICAL SYSTEM AND P/P PERFORMANCE CURVES  
(CENTRIFUGAL PUMP)

# System Performance Curve

## Step #3, Curve Mapping

- The friction loss is mapped onto the graph
- The amount of friction loss varies with flow through the system



**Head**

***Friction Loss***

***Pump Flow Rate***





The point on the system curve that intersects the pump curve is known as the operating point.

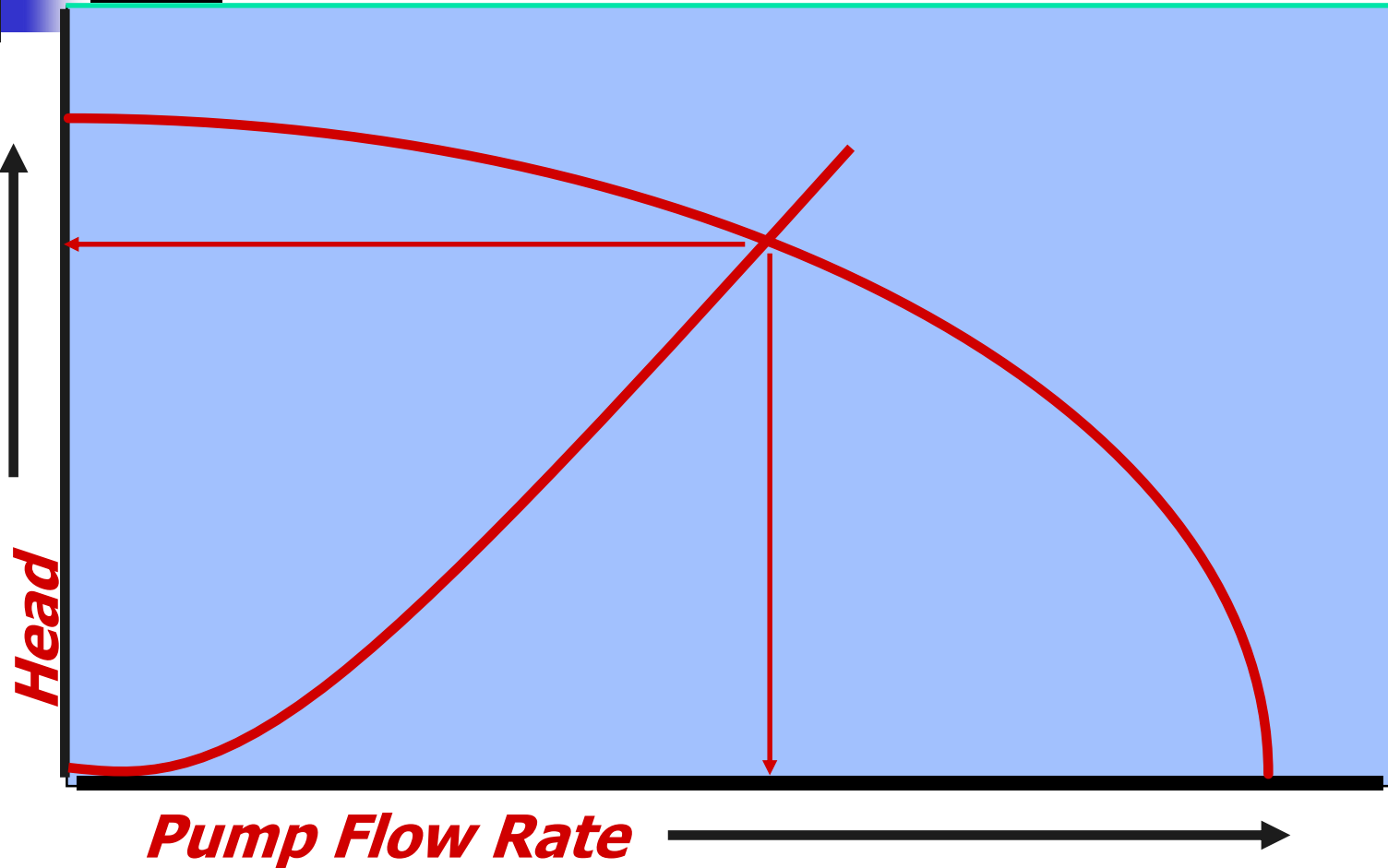

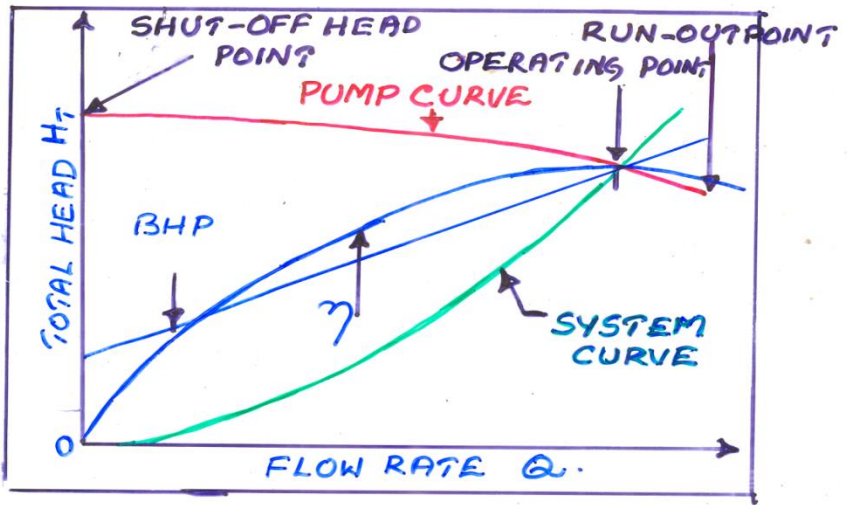

TYPICAL SYSTEM AND P/P PERFORMANCE CURVES (CENTRIFUGAL PUMP)

- \* SYSTEM RESISTANCE OR SYSTEM HEAD CURVE :— CHANGE IN FLOW WITH RESPECT TO HEAD OF THE SYSTEM. (THIS INCLUDES - PHYSICAL LAYOUT, PROCESS CONDITIONS, AND FLUID CHARACTERISTICS). IT REPRESENTS THE RELATIONSHIP BETWEEN FLOW AND HYDRAULIC LOSSES IN A SYSTEM. SINCE FRICTION LOSSES VARY AS SQUARE OF THE FLOW RATE, THE CURVE IS PARABOLIC.
- HYDRAULIC LOSSES IN PIPING SYSTEMS → PIPE FRICTION LOSSES, VALVES, ELBOWS AND OTHER FITTINGS, ENTRANCE AND EXIT LOSSES, AND LOSSES FROM CHANGES IN PIPE SIZE BY ENLARGEMENT OR REDUCTION IN DIAMETER.
- \* PUMP PERFORMANCE CURVE → GENERATED BY TESTS PERFORMED BY MANUFACTURER; BASED ON SPECIFIC GRAVITY 1.0. THE CURVE IS PLOTTED FOR A CONSTANT SPEED AND A GIVEN IMPELLER DIAMETER (OR SERIES OF DIAMETERS).

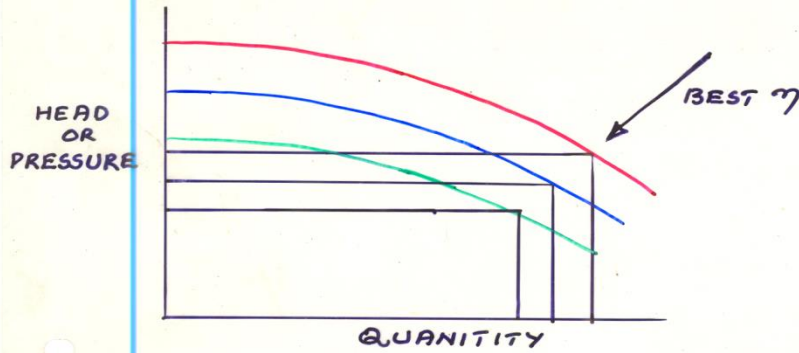

PERFORMANCE CURVES FOR CENTRIFUGAL PUMP IMPELLERS OF DIFFERENT DIAMETERS, SAME SPEED.

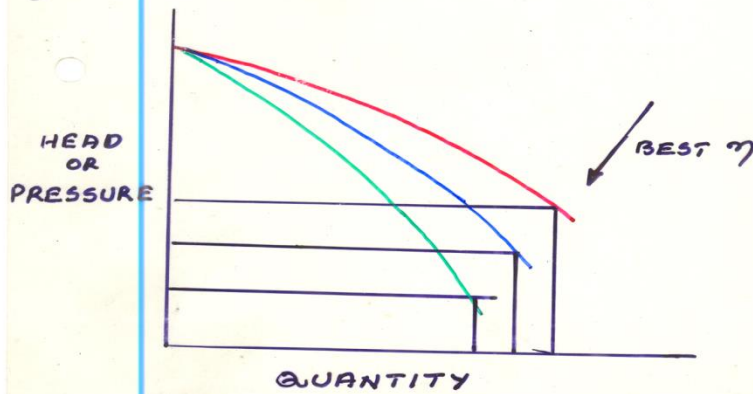

• PERFORMANCE CURVES FOR DIFFERENT WIDTH IMPELLERS OF THE SAME DIAMETER AND CONSTANT SPEED

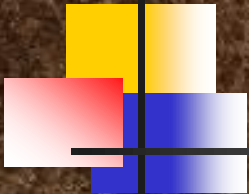
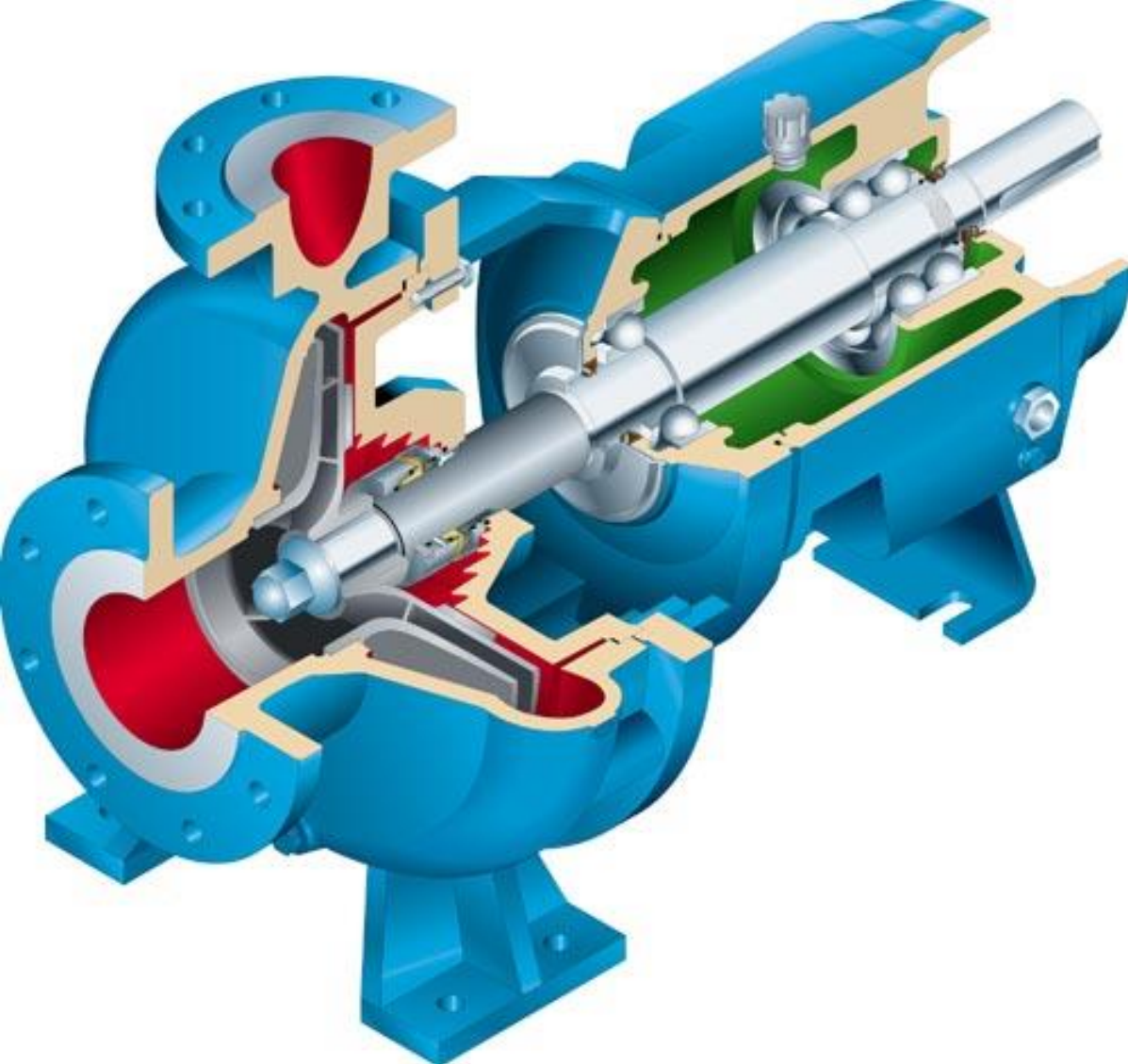

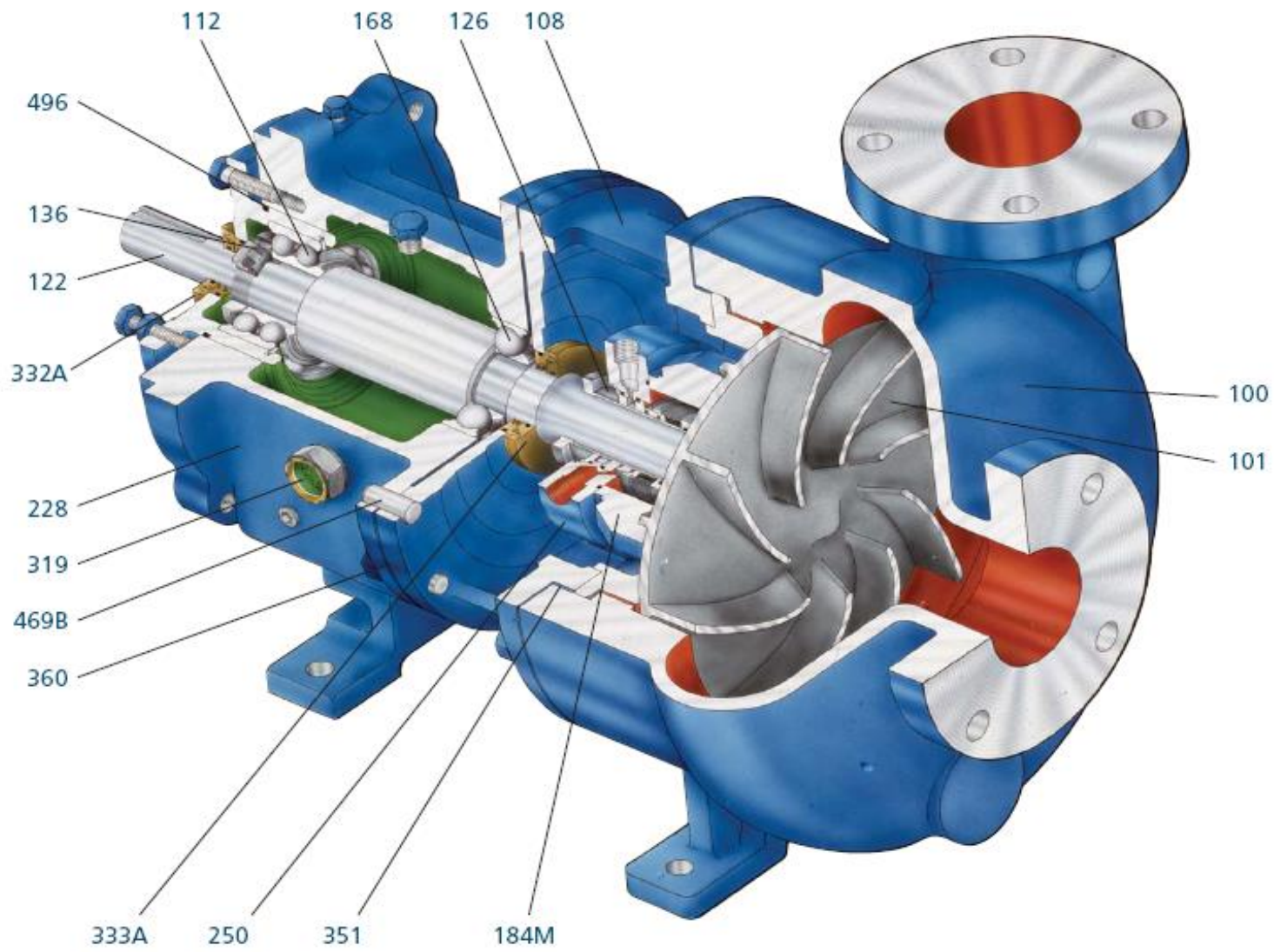

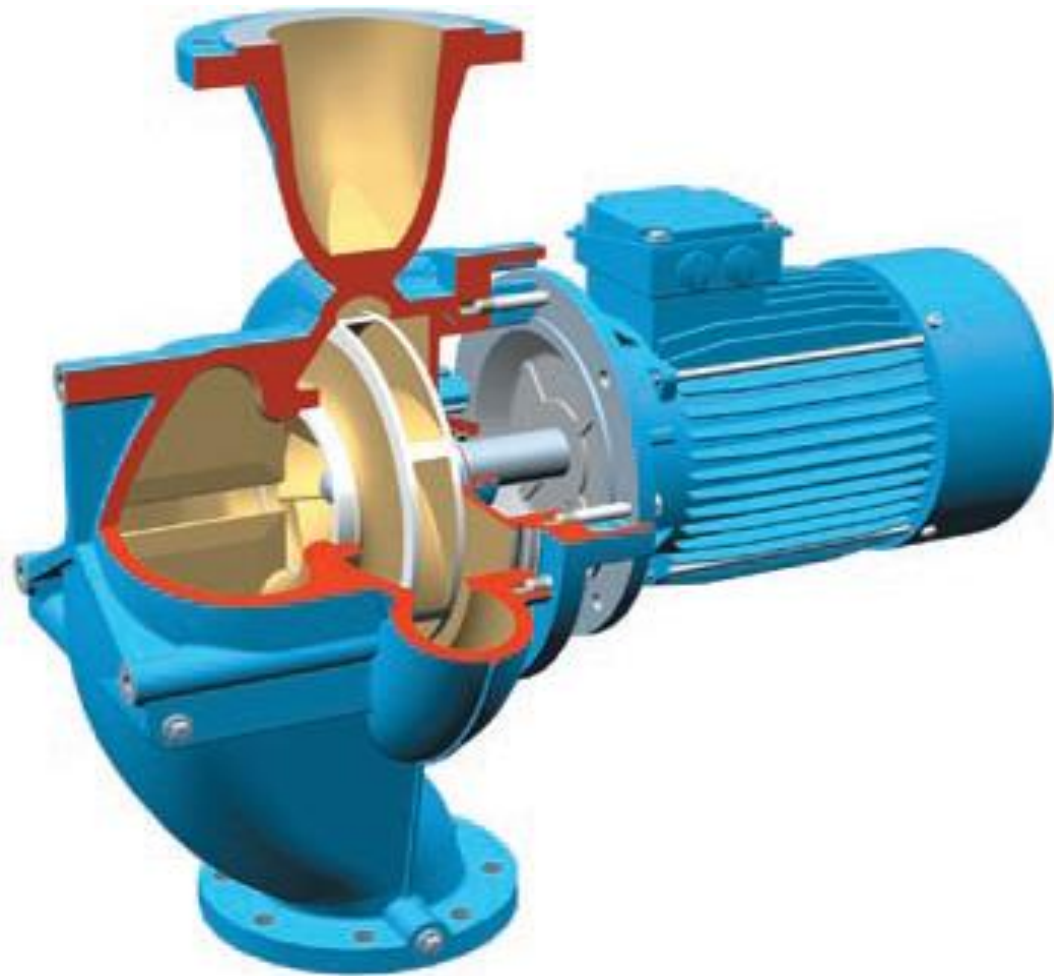
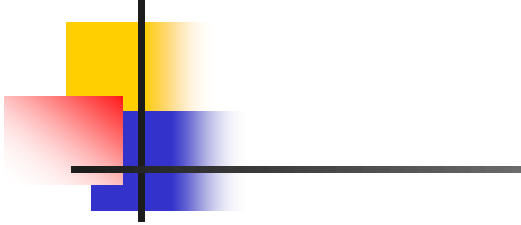

# Coupling

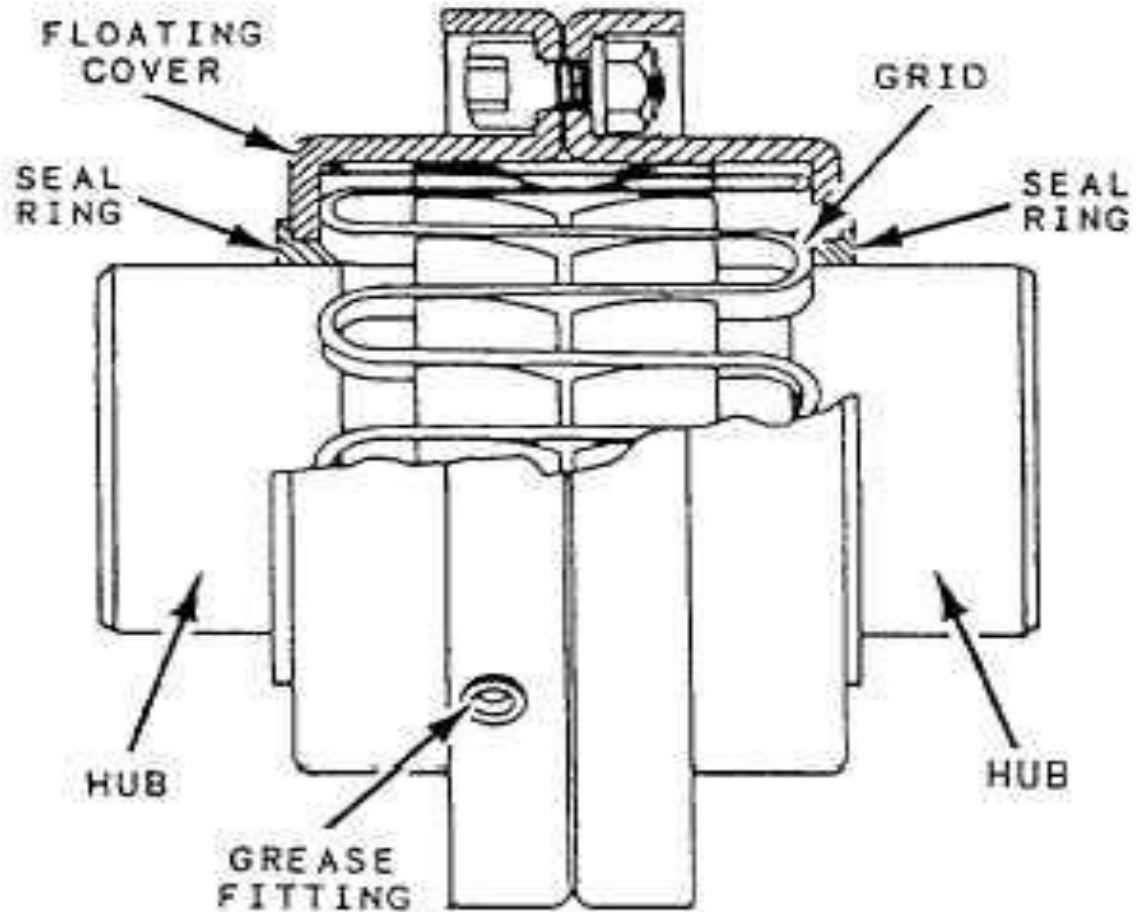

# Coupling Alignment

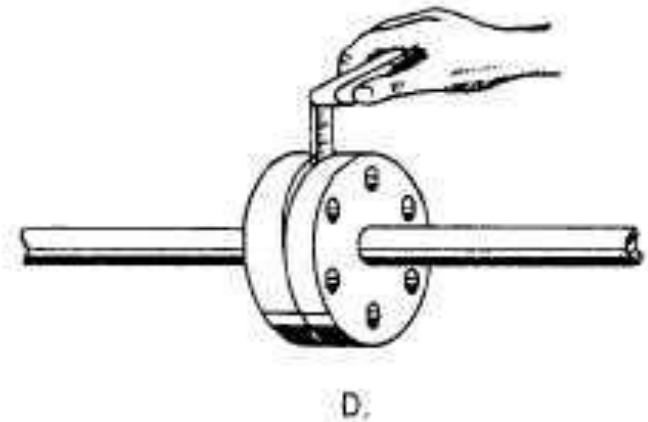
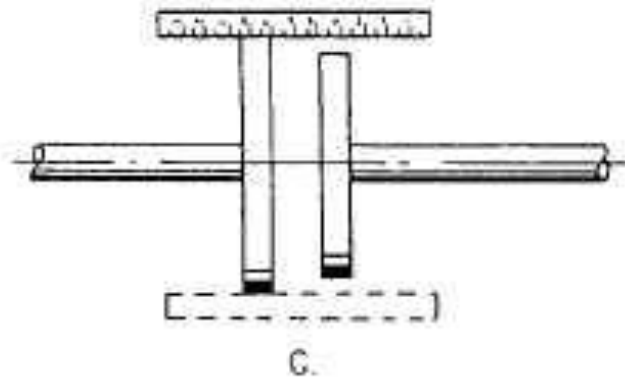
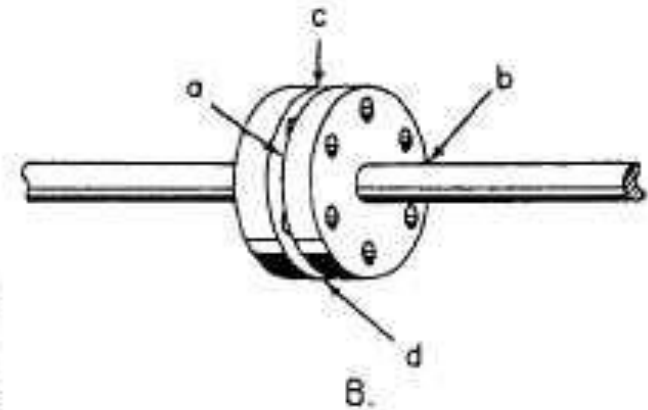
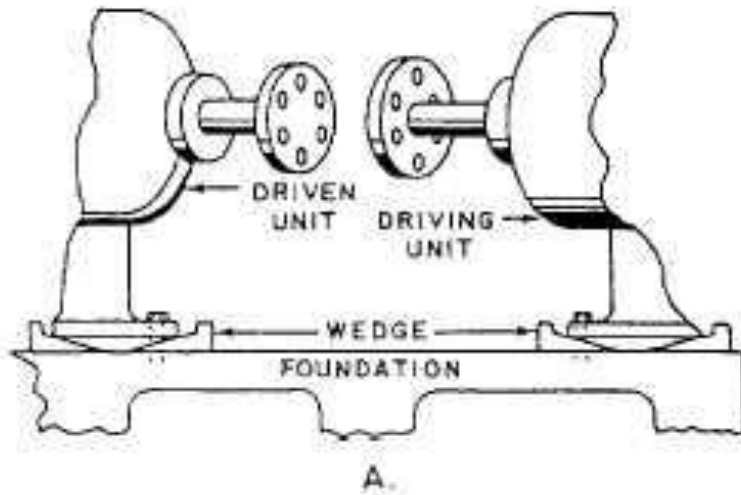



# Alignment

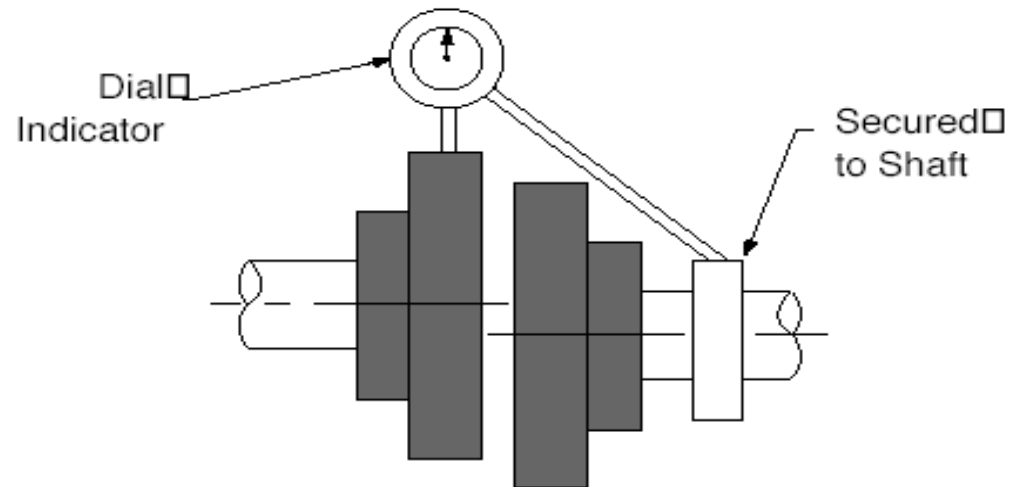
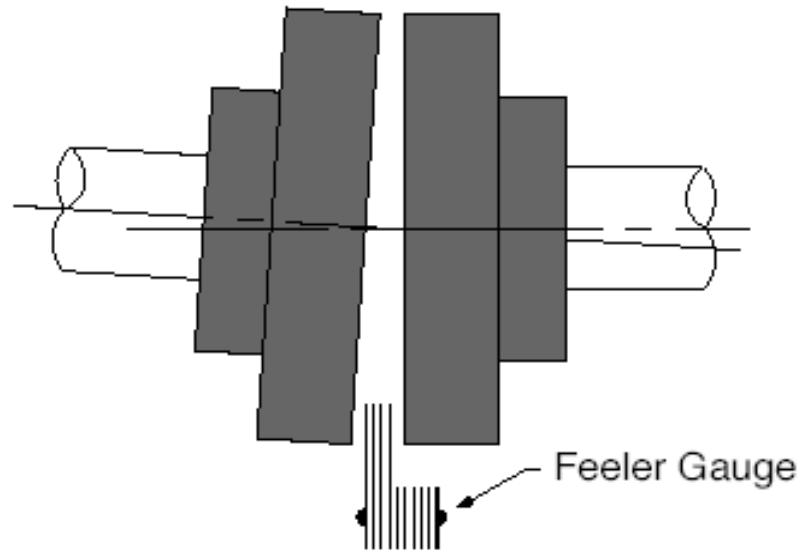

**FIGURE 79. Dial Indicator Method of Checking Parallel Alignment**

Amount of parallel misalignment

Straight edge

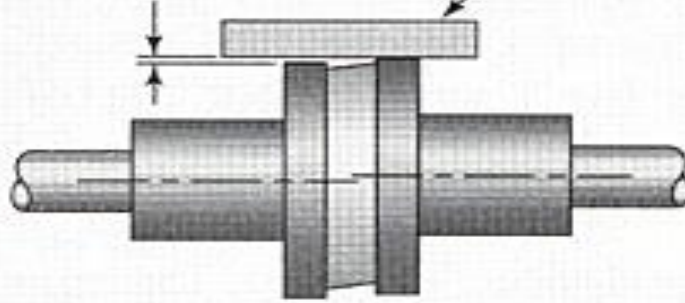

Parallel alignment check

Figure 2

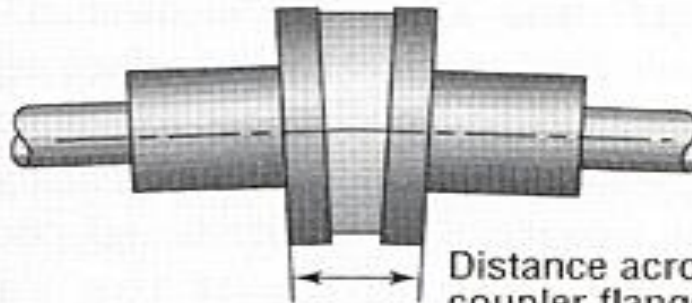

Distance across coupler flanges should be equal (check 4 places)

Figure 3



# Centrifugal P/P, O'hauling

---

## Basic Types of Parts:-

Rotating Parts – Impeller, Shaft, wearing rings, shaft sleeves, bearings, Mechanical seal etc

Stationary Parts – Casing, bearing housing, suction and discharge flanges, packing, leak-off tubing, base plate etc

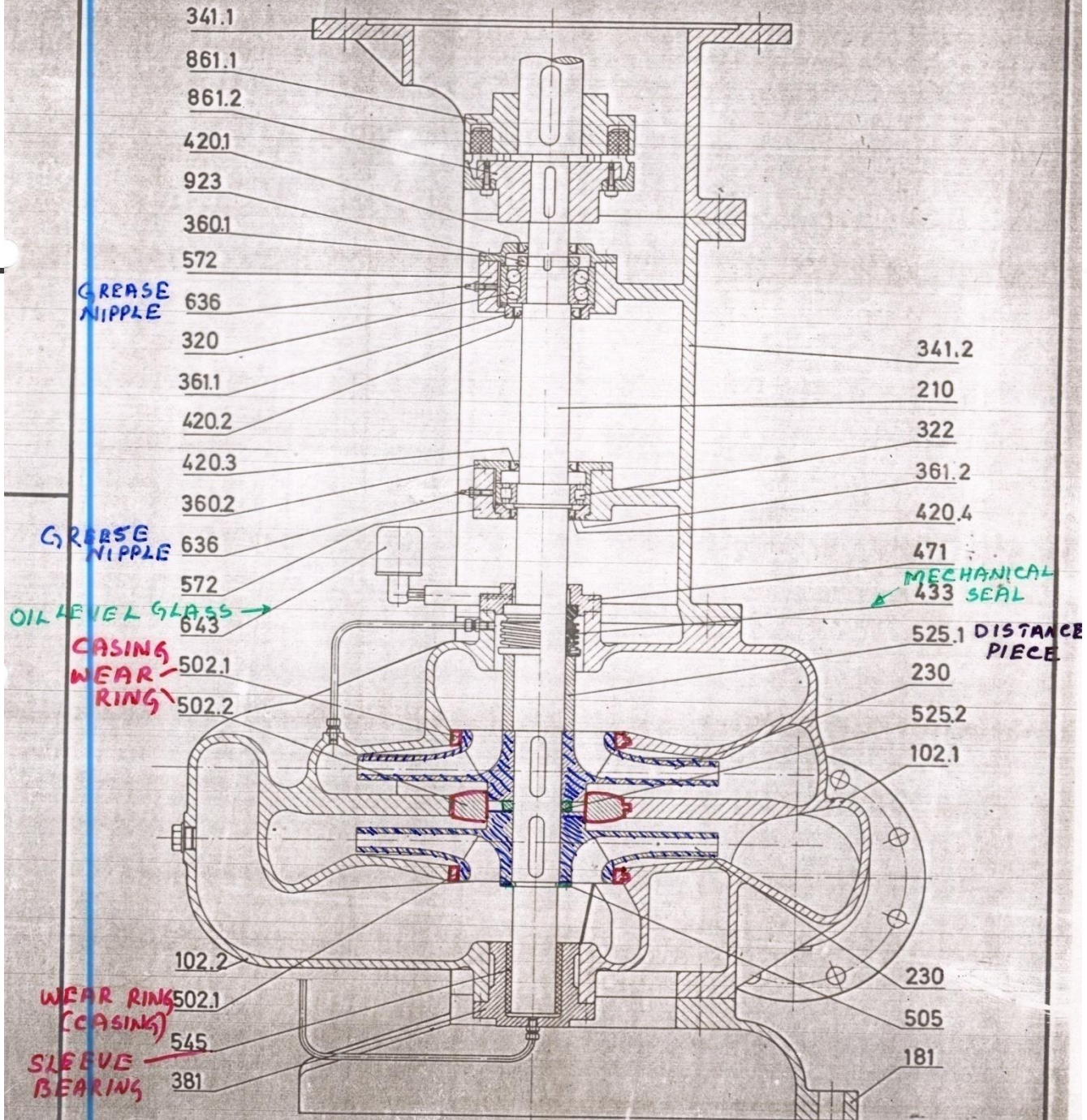



# Cent: P/P, O'hauling- Impeller

Inspect eyes, vanes, shrouds, wearing rings, passages, hubs and other parts.

Corrosion, Cavitation, and Erosion are generally accompanied by a wasting away of the impeller and vane surfaces. Where attack is severe, the thinned sections may have holes through them or may warp and deflect.

Badly worn or corroded impellers may vibrate excessively. Balancing is required. Check on a lathe. Metal to be removed on heavier side. If required take a cut on the shroud, deepest at the rim.

Compare with a spare Impeller.

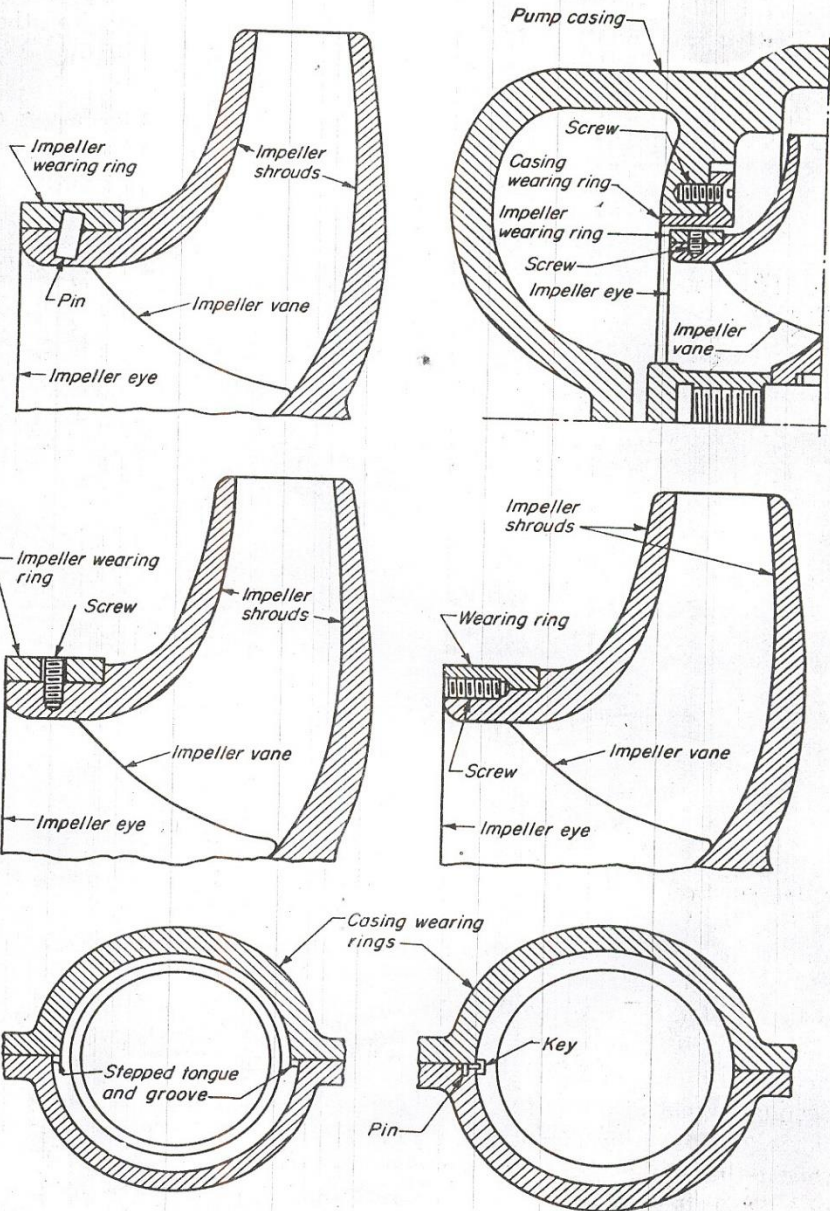

FIG. 6-21. Typical wearing rings. (Courtesy of Allis-Chalmers Mfg. Co.)

# Cent: P/P, O'hauling- shaft

- ❖ **Check for bent shaft; out of square, dirty or burred impeller end of the shaft or spacer sleeve.**
- ❖ **Check – Lock nut washer is burred or the faces of it and other parts are not parallel.**
- ❖ **Check for bent shaft by means of a dial gauge, swinging between lathe or other centers.**
- ❖ **Tap and check impeller shaft key to see it is tight. Twist of shaft under load, Expansion or corrosion will progressively loosen the impeller..**



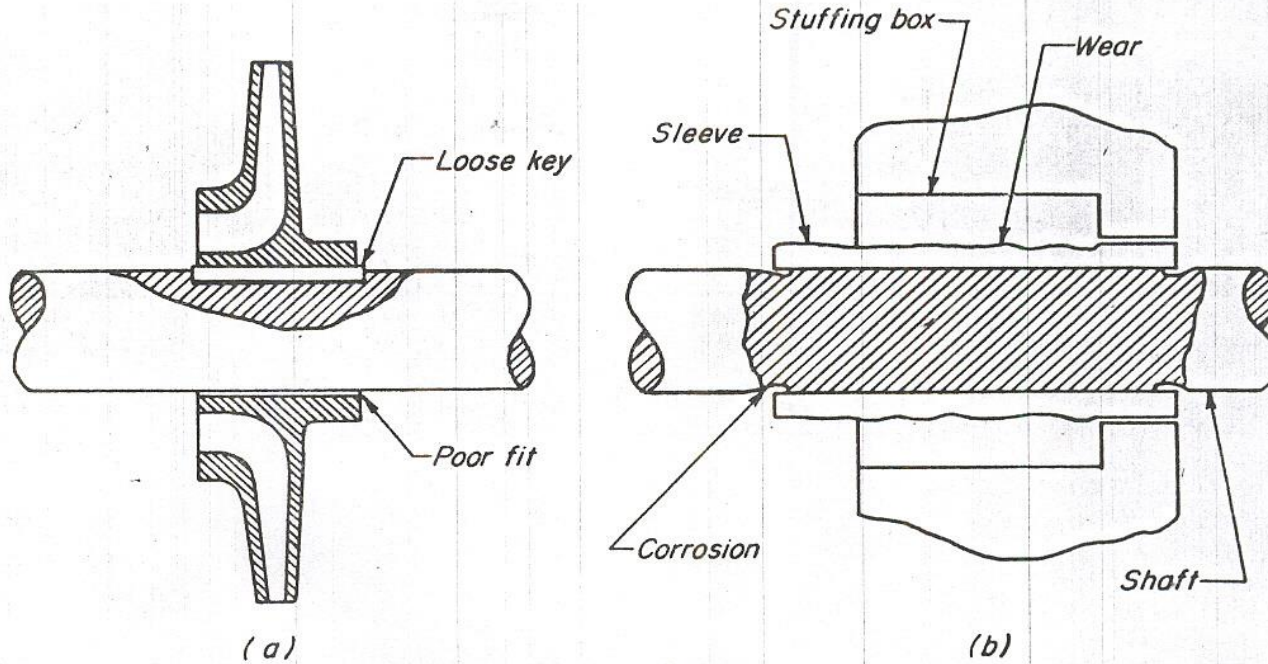



FIG. 6-13. (a) Impeller-fit troubles. (b) Worn shaft and sleeve. (Courtesy of Power.)

# Cent:P/P O'hauling- wear ring

- 
- ✓ Wear rings are installed in the casing or impeller or both. It will run as bearings while lubricated by the fluid being pumped. Check the clearances to make sure it is within limits. If not replace the wear rings.
  - ✓ Wear rings are usually made out of non-galling materials. EX: Bronze with dissimilar bronze.
  - ✓ Make sure that the wear rings are fitted correctly.



# Cent:P/P- O'hauling- Bearings

---

- Ball bearings etc. – Keep all rolling-contact bearings clean at all times. Use clean tools and clean surroundings. Use clean solvents and flushing oils. Clean inside of housing before replacing the bearings. Install new bearings as removed from their package, without washing. To remove a bearing, press or pull only on the rings which is tight press; pull straight.
- Sleeve/Bush bearings – Check clearances, if over the limit value, replace the same.

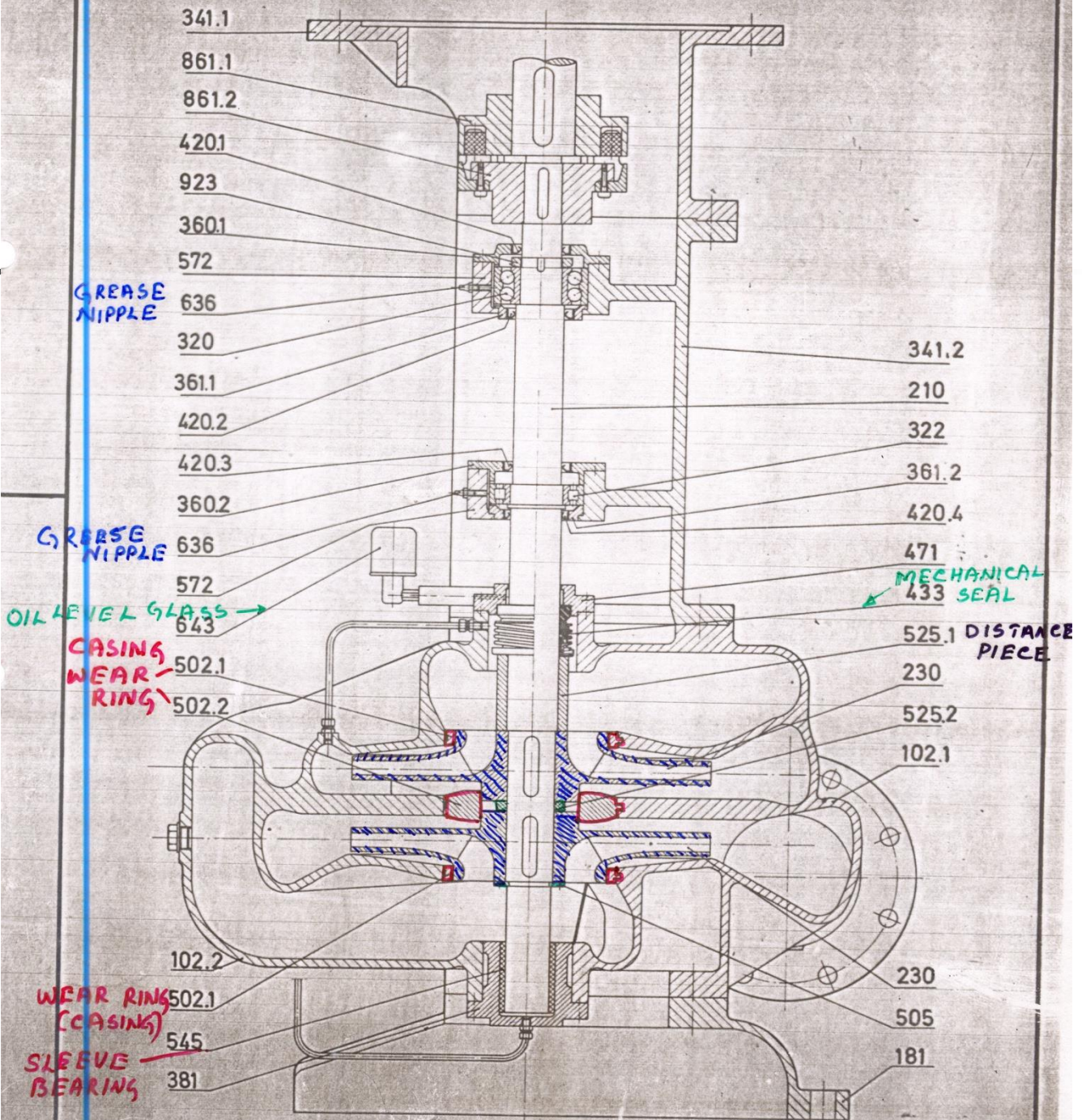
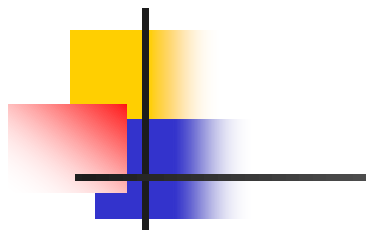

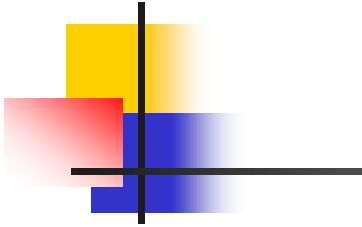

# Cent:P/P,O'hauling-Mechanical seal.

- o Normally only faces require repair.
- o If stationary face is slightly scored, lap it on a lapping plate. If dirt or scale is imbedded, take a cut in lathe, to remove material to below the imbedded element.
- o Remove spring assembly for cleaning and inspection.
- o For replacement, choose the correct type.
- o Good Practice – To rotate pumps equipped with mechanical seals, once a day, when stopped.

# Cent:P/P, O'hauling, Shaft Sleeve, Gland Packings.

---

- Check for worn shaft and shaft sleeve. Machine it and use it if groove/wear is not deep. Otherwise replace the sleeve. Check and replace the sealing ring of the sleeve.
- Remove and replace all gland packings with correct type and size packings. Clean the housing thoroughly before inserting the packings.
- Do not over-tight the gland. Check by rotating the shaft by hand.

# Cent:p/p,O'hauling, Stationary Parts

---

- ✓ **Casing:- Examine for corrosion or erosion. May be repaired by welding, brazing and machining or metal spraying; depending on the material.**
- ✓ **Gaskets:- To be renewed with correct thickness and type. Surface of gasket seating has to be clean. Do not use oil, grease or varnish. Use proper tightening sequence for casing bolts and studs.**
- ✓ **Bedplate and Foundation:- Keep clean, Check for irregularity, keep drain lines clear. Check foundation bolts for tightness.**
- ✓ **Piping:- Check for leaks, damaged insulation, water hammer, defective valves, improper alignment etc.**



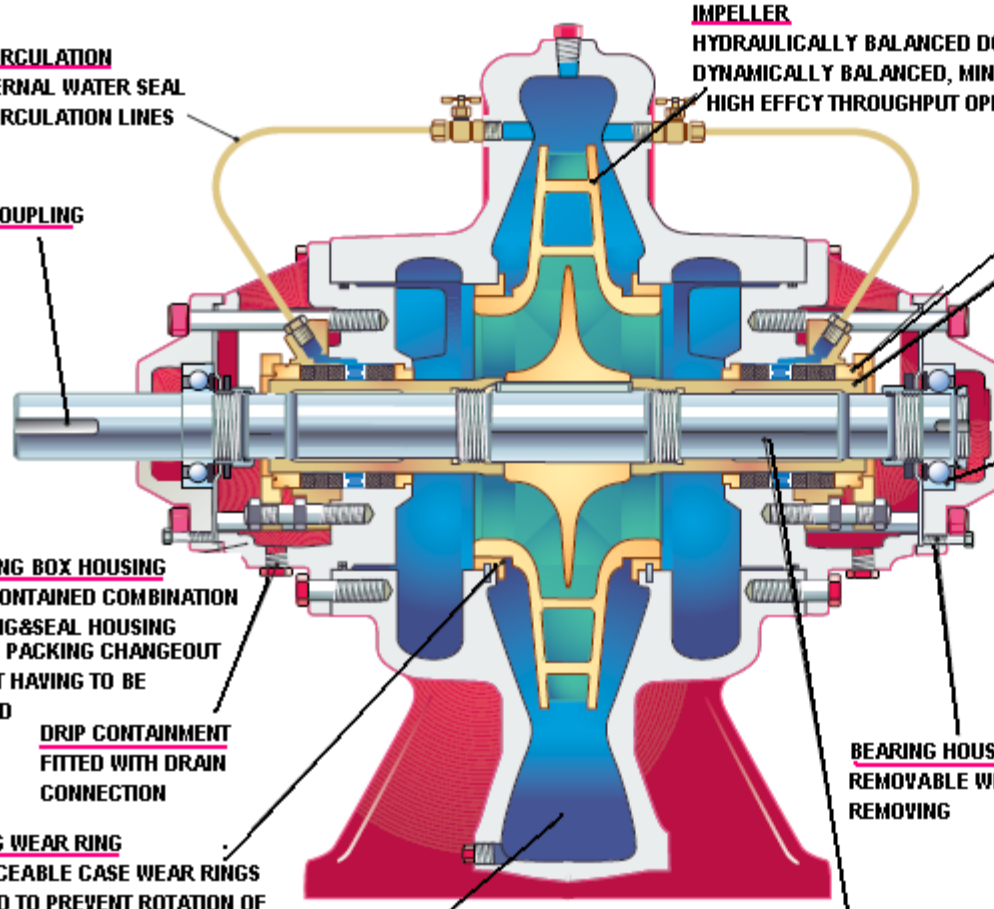

**RECIRCULATION**  
EXTERNAL WATER SEAL  
RECIRCULATION LINES

**COUPLING**

**STUFFING BOX HOUSING**  
SELF CONTAINED COMBINATION  
BEARING&SEAL HOUSING  
PERMITS PACKING CHANGEOUT  
WITHOUT HAVING TO BE  
REMOVED

**DRIP CONTAINMENT**  
FITTED WITH DRAIN  
CONNECTION

**CASING WEAR RING**  
REPLACEABLE CASE WEAR RINGS  
LOCKED TO PREVENT ROTATION OF  
AXIAL DISPLACEMENT

**PUMP CASING**  
DESIGNED TO WITHSTAND THE HIGH  
PRESSURE REQUIREMENT TYPICAL IN  
FIRE PROTECTION

**IMPELLER**  
HYDRAULICALLY BALANCED DOUBLE SUCTION  
DYNAMICALLY BALANCED, MIN AXIAL THRUST  
HIGH EFFCY THROUGHPUT OPERATING RANGE

**SHAFT SEALING WITH PACKING**  
3 PIECE SPLIT GLAND STANDARD  
PACKING REPLACEABLE WITHOUT  
DISTURBING WETTED PARTS

**SHAFT SLEEVES**  
\*REPLACEABLE  
BRONZE SLEEVES  
\*PROTECTS SHAFT  
THROUGHOUT ST. BOX  
**BEARINGS**  
EASY REMOVAL WITH BEARING NUT  
SEALED, PERMANENTLY GREASED BRG'S  
LOW FRICTION LOSS BRG  
MAINTENANCE FREE

**TILTED PARTING DESIGN CASING**  
PERMITS LAMINAR APPROACH TO EYE OF IMPELLER  
LOWER NPSH REQUIRED , LOWER P/P PROFILE  
MIN P/P FOOTPRINT , REMOVABLE ROTATING  
ELEMENT WITHOUT DISTURBING PIPING , LOW FOOT  
MOUNTED CASING TO REDUCE VIBRATION

**BEARING HOUSING**  
REMOVABLE WITHOUT  
REMOVING

**SHAFT**  
MINIMUM DEFLECTION FOR LONG  
BEARING LIFE , MINIMUM  
VIBRATION  
IDENTICAL SHAFT FOR LEFT&RIGHT  
HAND DRIVES

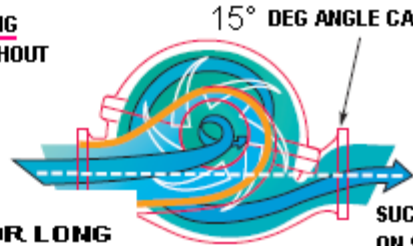

**SUC & DISCH**  
ON SAME CALINE

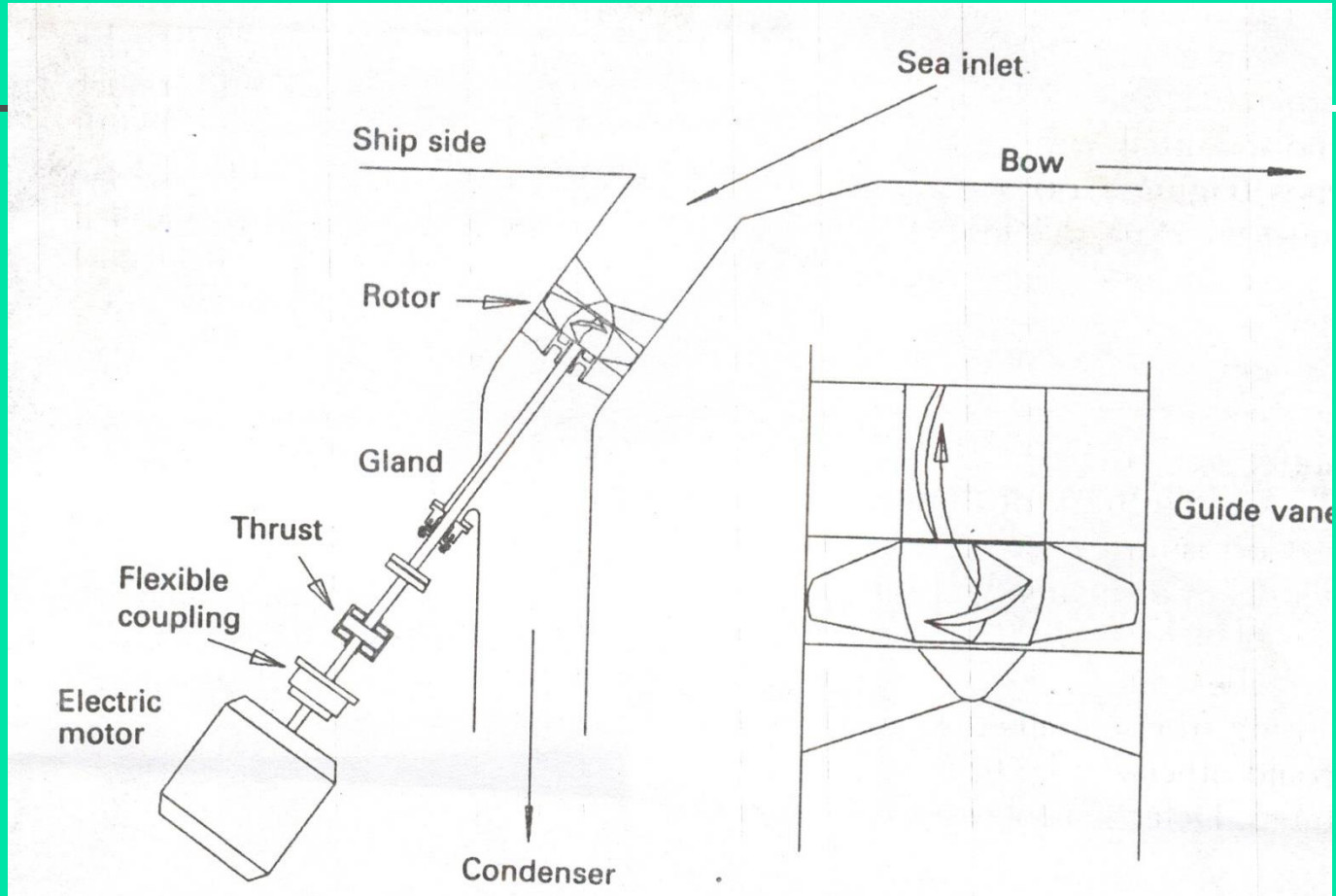

**Figure 1.12** Scoop system for steamship with axial flow pump

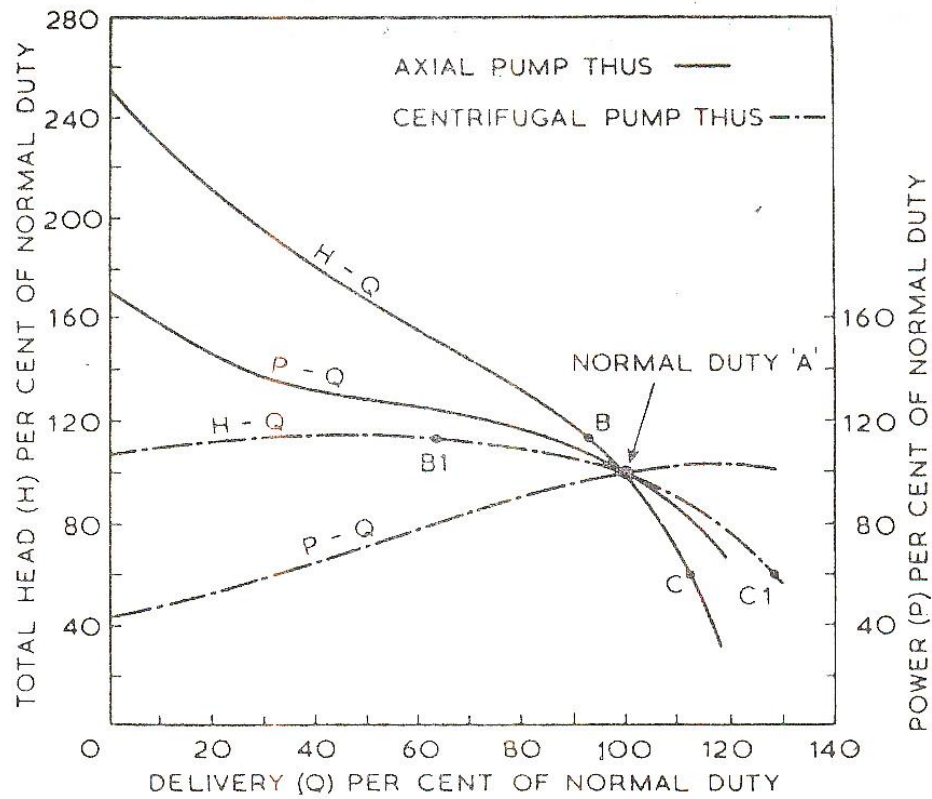

**Figure 5.20** Head/quantity curves, at constant speed, of axial-flow and centrifugal pumps

# Axial Pump

- 
- 
- ❖ Under low head ( 2.5 to 6.2 m), High throughput (2800- 9500 m<sup>3</sup>/hr )- conditions required by main condensers in steam ships.
  - ❖ Pump is reversible.
  - ❖ Pump will idle and offer little resistance when flow is induced through it by external means.
  - ❖ Ideal for condenser circulating duties in steam ships and for heeling and trimming duties.

# Axial Flow Pump

- A screw propeller by causing an axial acceleration of liquid within its blades, creates a pressure increase.
- Incidental rotation imparted to the liquid is converted to axial movement by suitably shaped outlet guide vanes.
- Throttling of the discharge valve causes a rise in pressure and power. With discharge valve closed and zero discharge, the head will be three times and power doubled. Causes water hammer.

# Axial Flow Pump

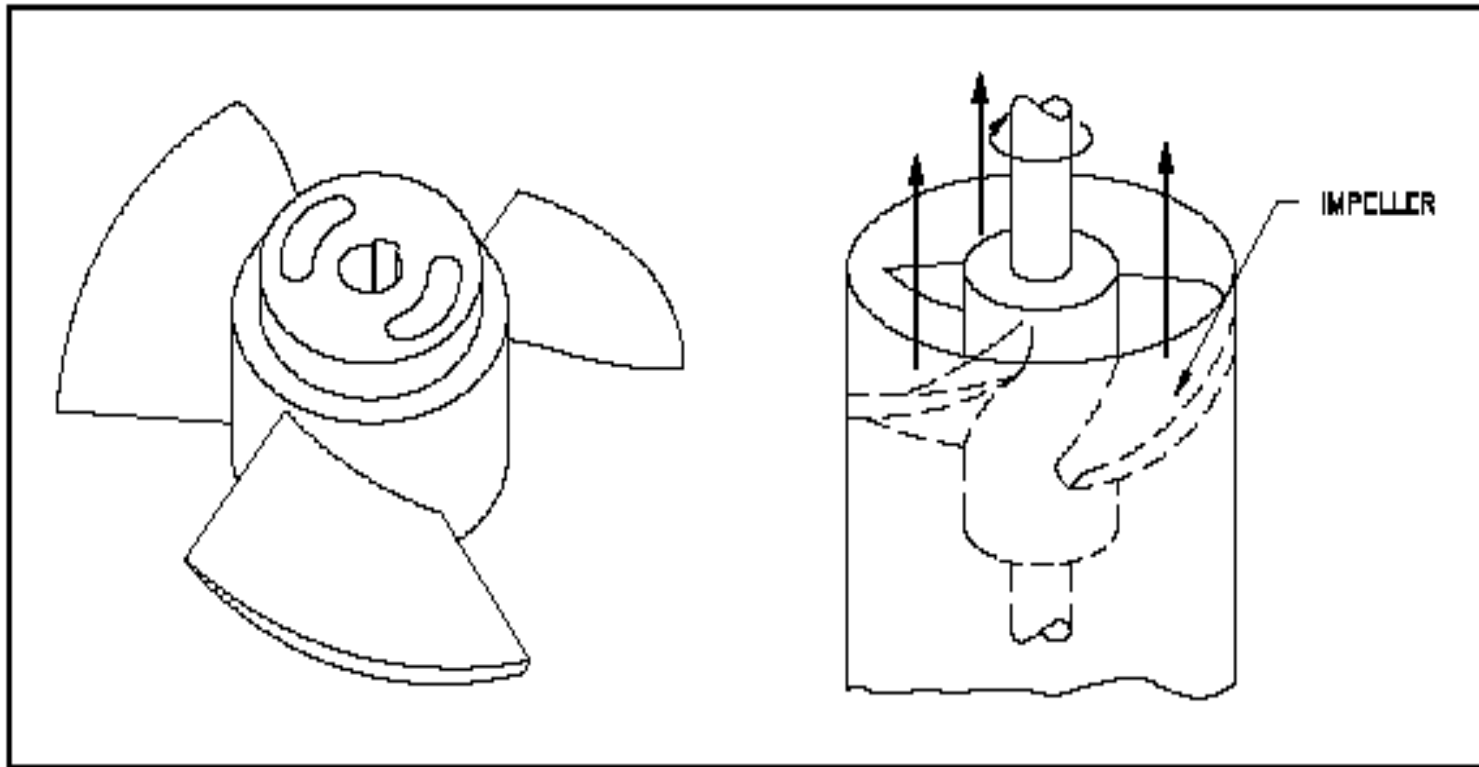



# Ejector

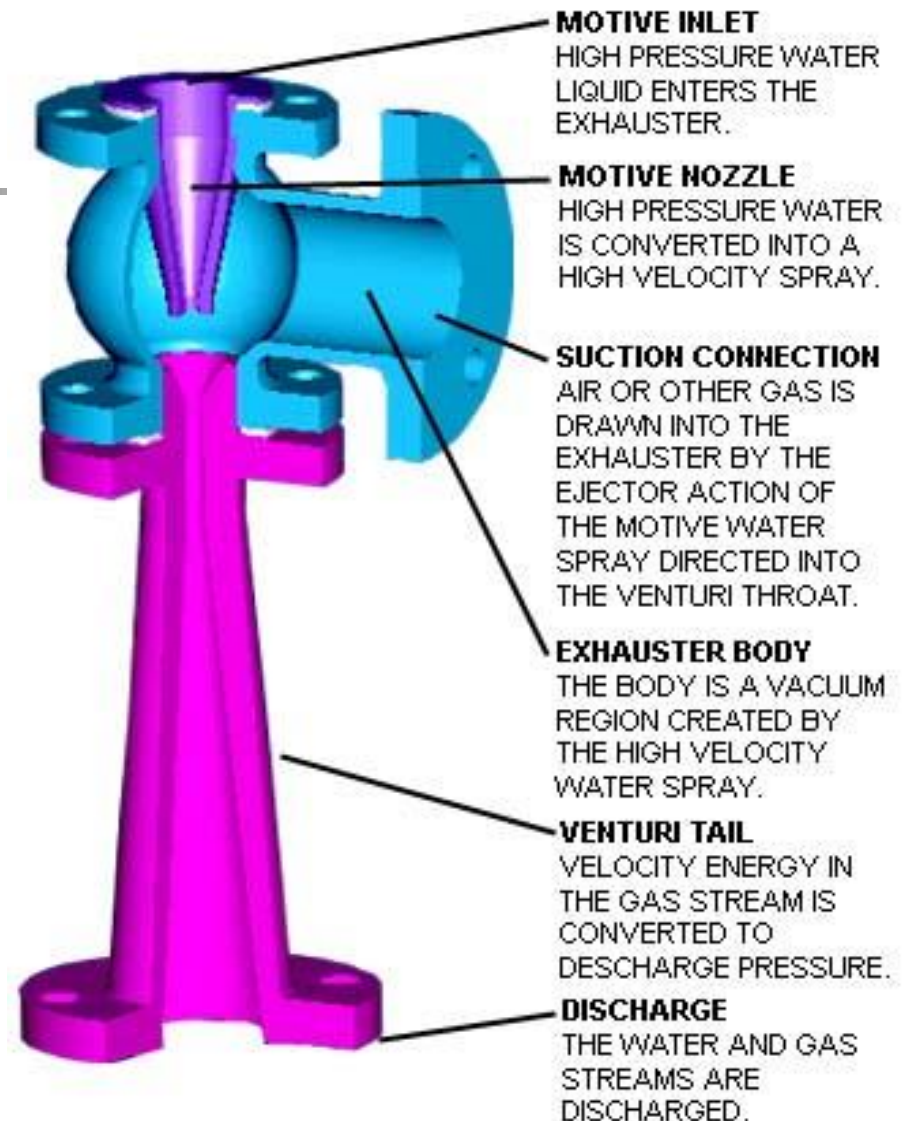

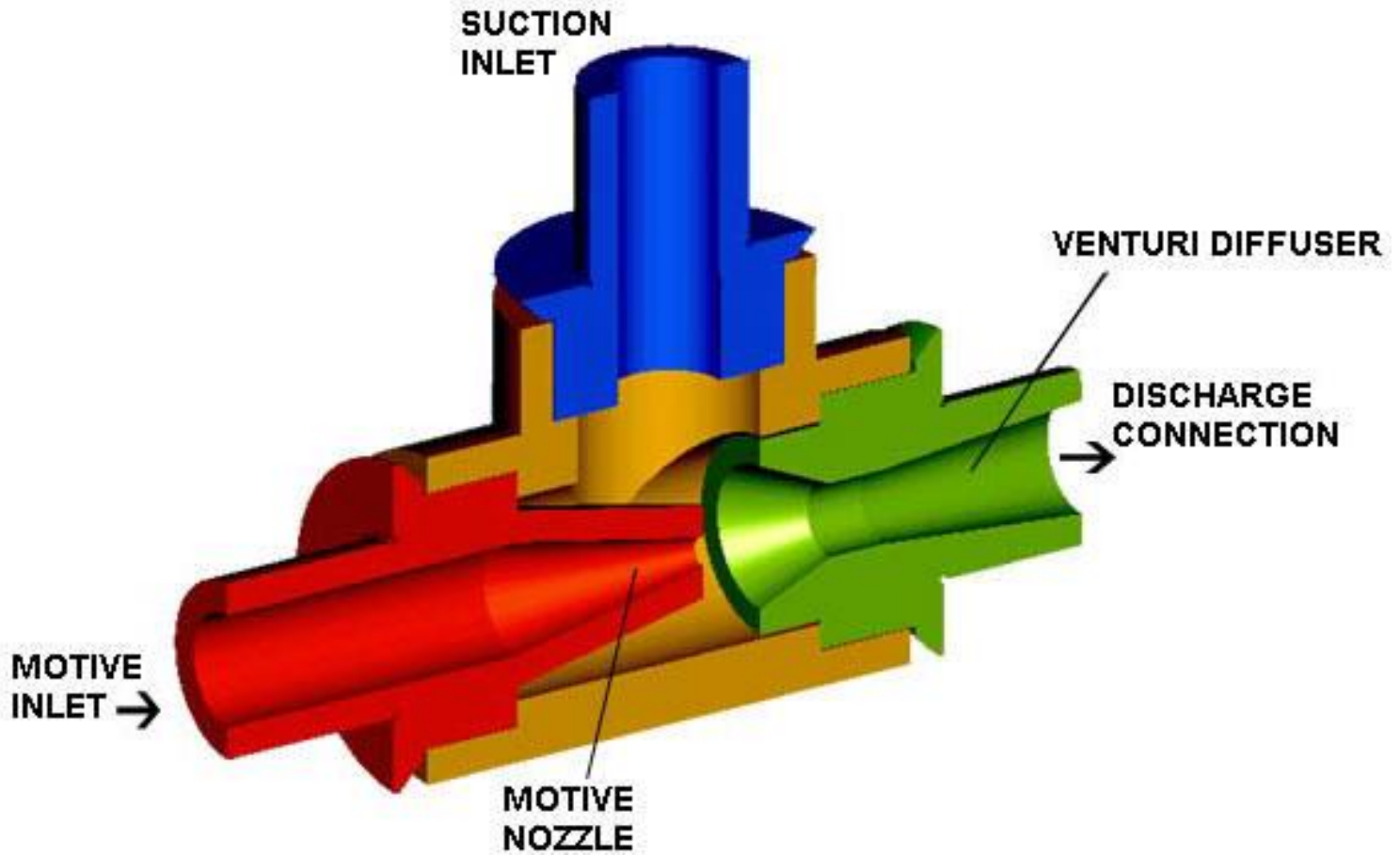
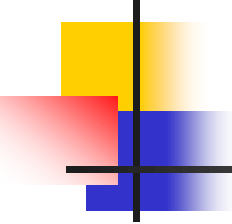



16

EM-2				
EM-1	FLANGE	SS41	1"	
DI-4	BOLT & NUT	STEEL	25C	16" M30

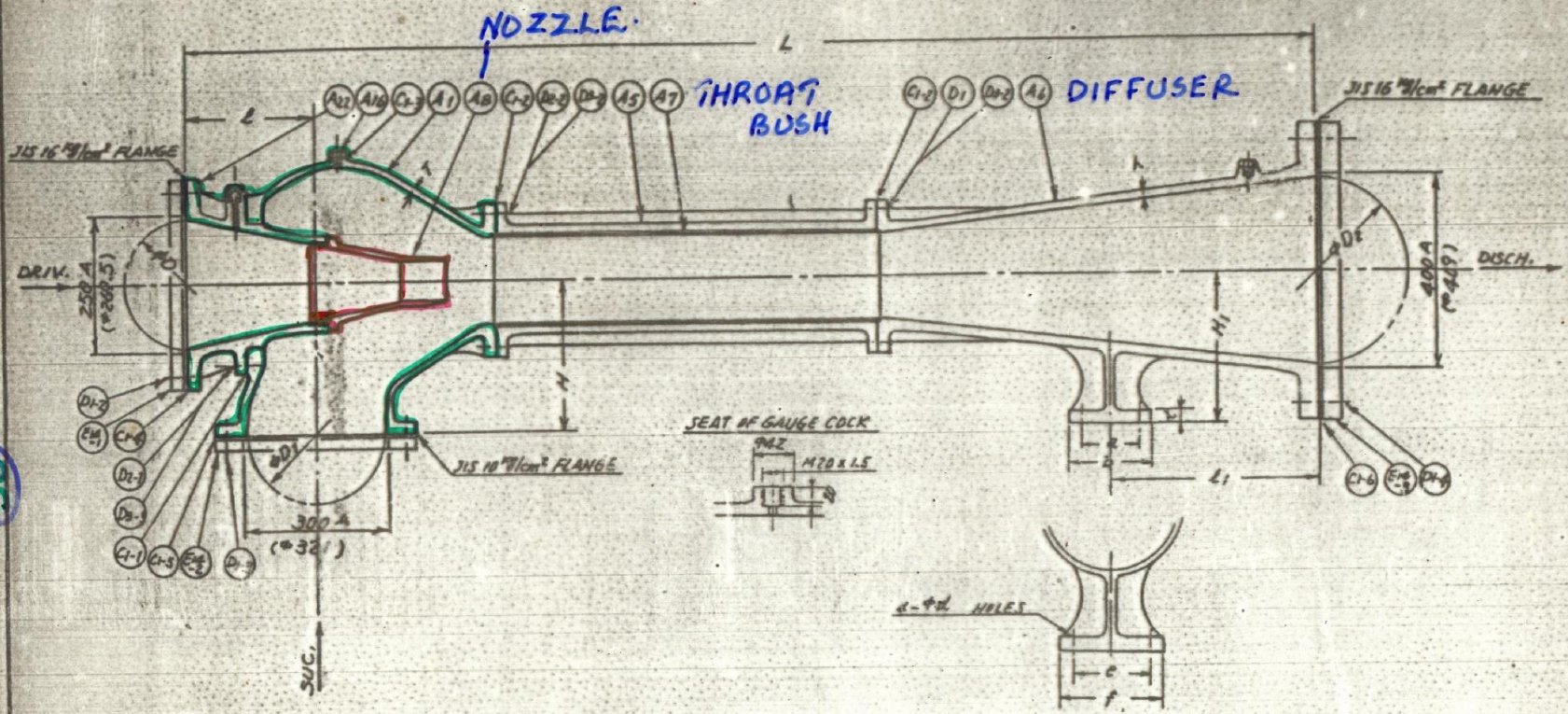

38



# Positive Displacement Pumps.

---

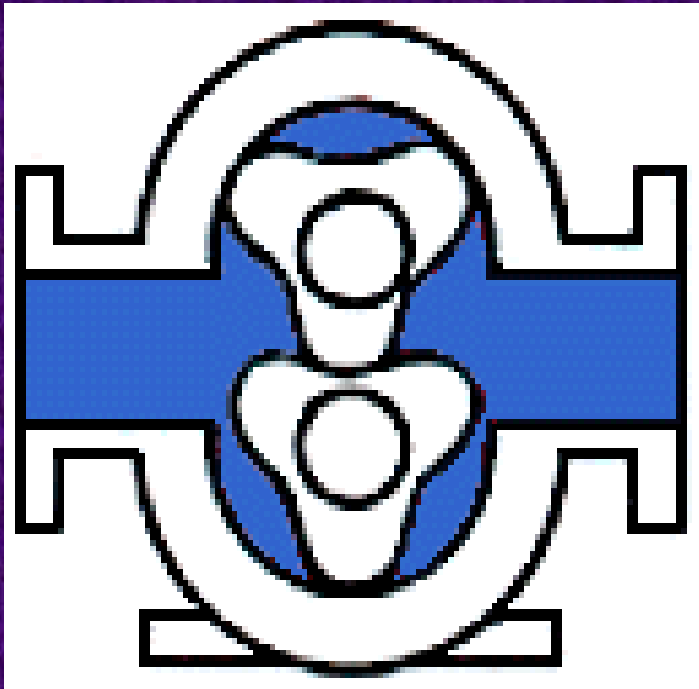

- ❖ Liquid or gas displaced from suction to discharge by mechanical variation of the volume of a chamber or chambers.



# Types of Positive Displacement Pumps.

---

- ❖ RECIPROCATING – Plunger or Piston mechanically reciprocated.
- ❖ ROTARY – Liquid forced through the pump cylinder or casing by means of screws or gears etc.



# **Necessity of Relief Valve in Positive Displacement Pumps.**

---

- ❖ **Positive Displacement Pumps will produce increasing pressure until rupture or drive failure.**
- ❖ **Hazardous material discharge from Relief Valve must be contained within the pumping system.**

# Types of Positive displacement Pumps.

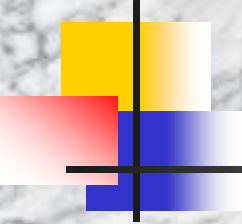
- 
- 
- ❖ **Reciprocating piston pump.**
  - ❖ **Gear type rotary pump.**
  - ❖ **Lobe type rotary pump.**
  - ❖ **Screw type rotary pump.**
  - ❖ **Moving vane type pump.**
  - ❖ **Diaphragm pump.**
  - ❖ **Flexible vane pump.**

# Types of P D Pumps

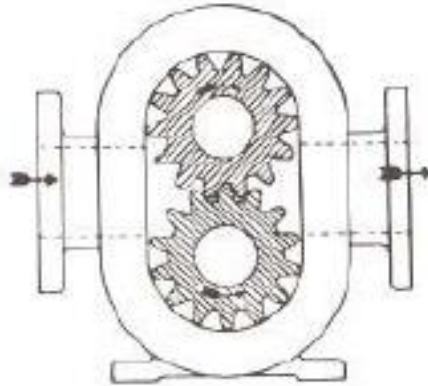

Fig. 1 External Gear Pump

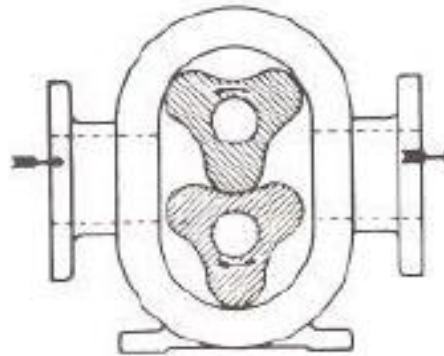

Fig. 2 Three Lobe Pump

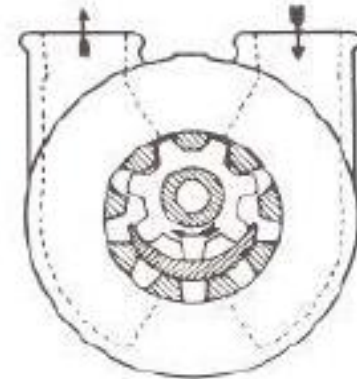

Fig. 3 Internal Gear Pump

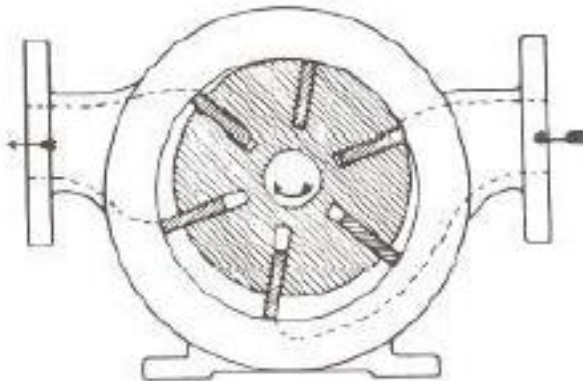

Fig. 4 Sliding Vane Pump

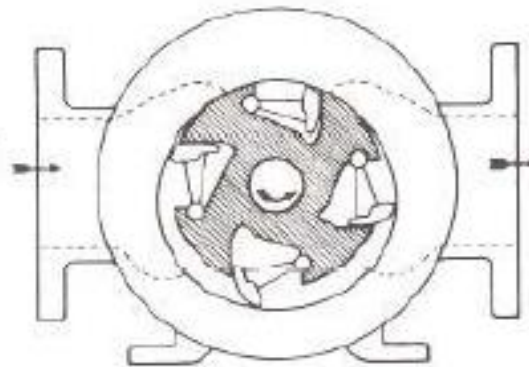

Fig. 5 Swinging Vane Pump

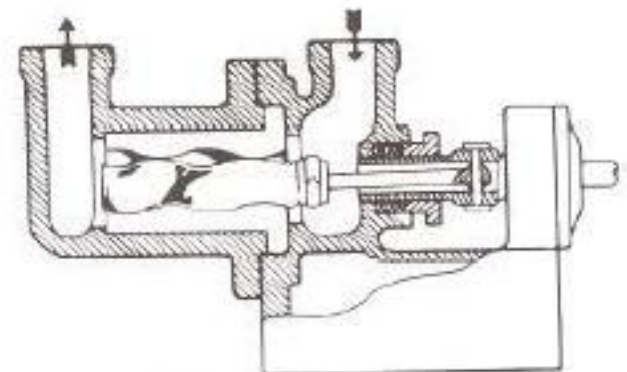
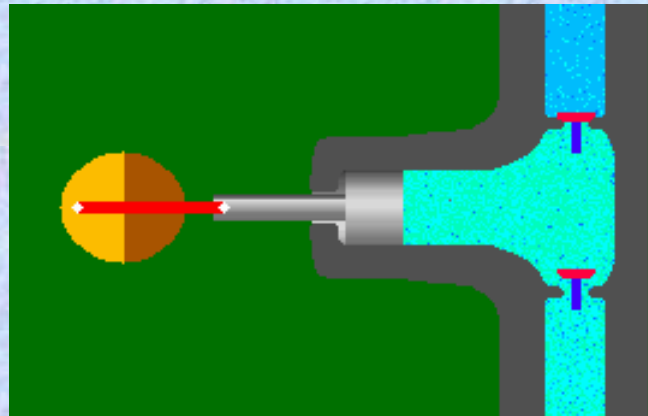

Fig. 6 Single Screw Pump



# Piston Pump

---



# **Direct Acting Reciprocating pump classified as**

- ❖ Horizontal or Vertical ( H or V )**
- ❖ Single or Duplex ( S or D )**
- ❖ Single or Double Acting ( SA or DA )**



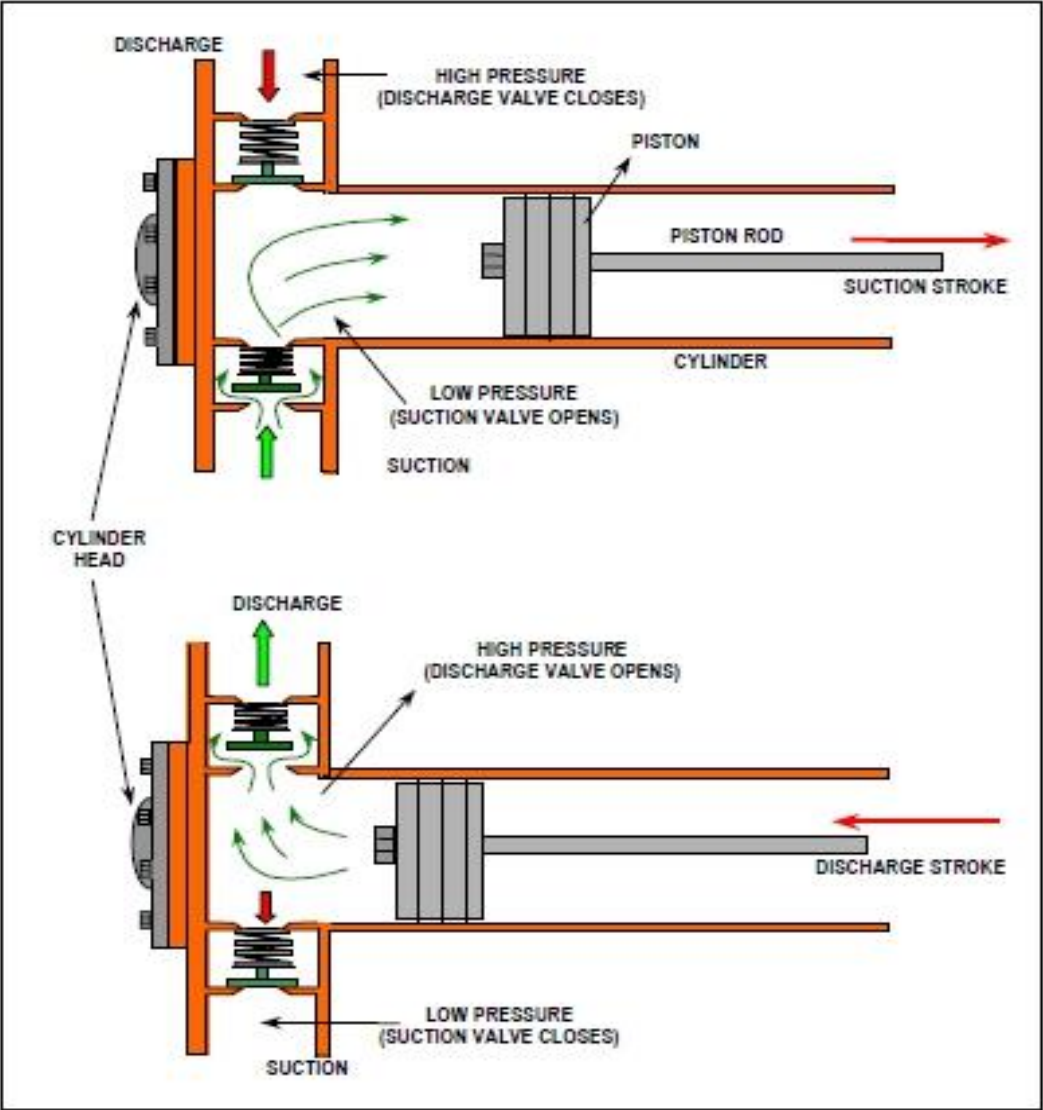

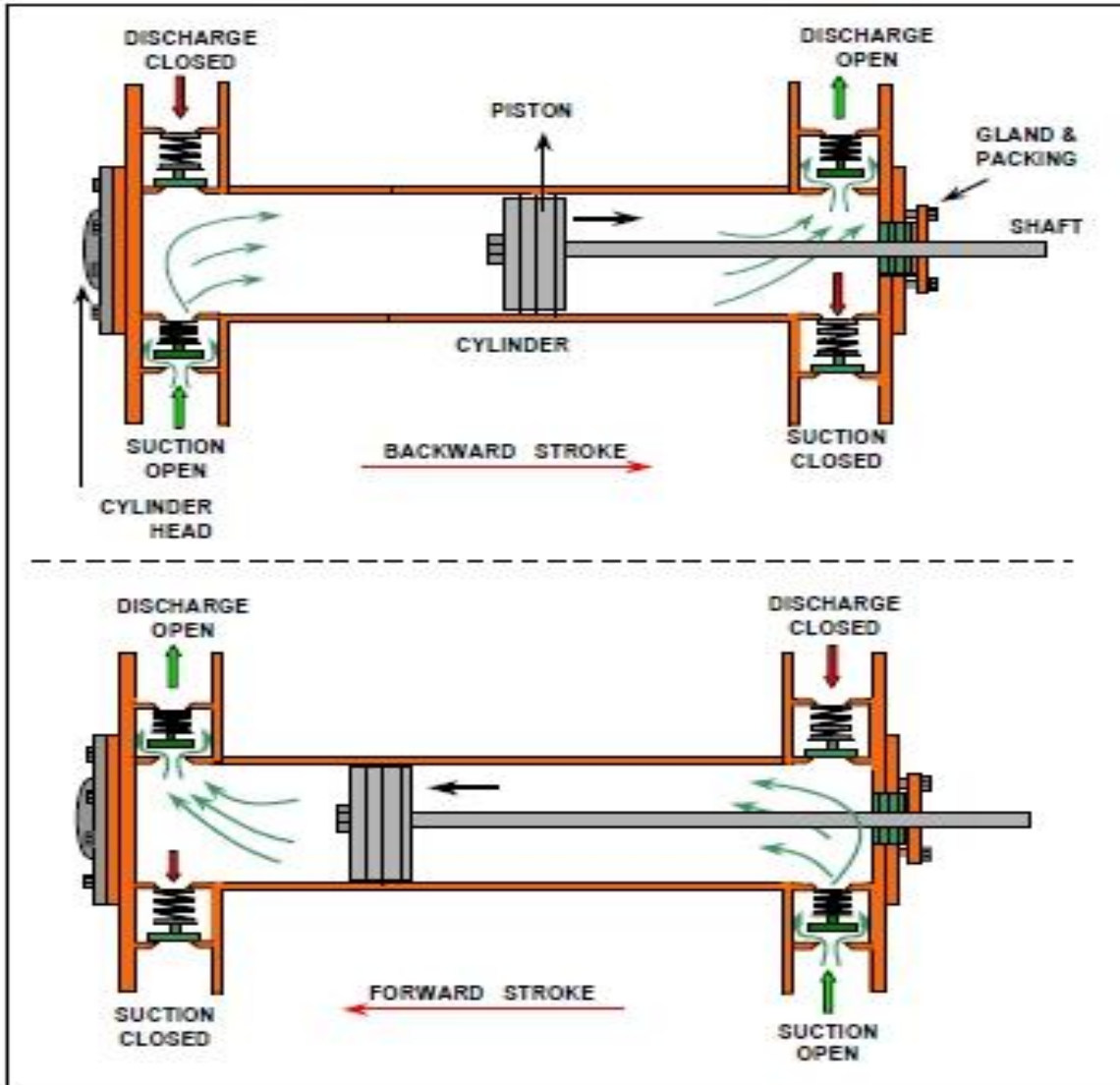

PISTON ROD TO  
PUMP/COMPRESSOR

CROSSHEAD GUIDES

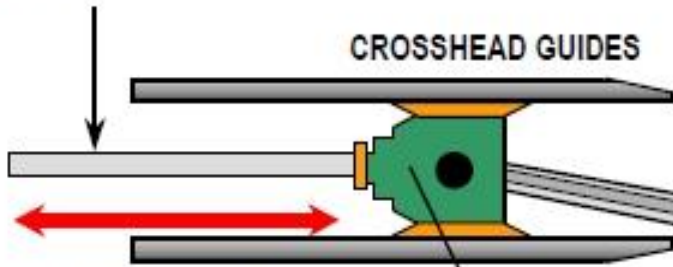

RECIPROICATION

CROSSHEAD



CONNECTING ROD

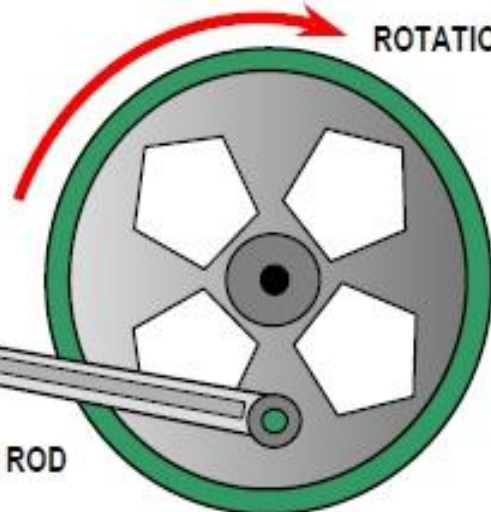

ROTATION

WHEEL & CAM

# Plunger Pump

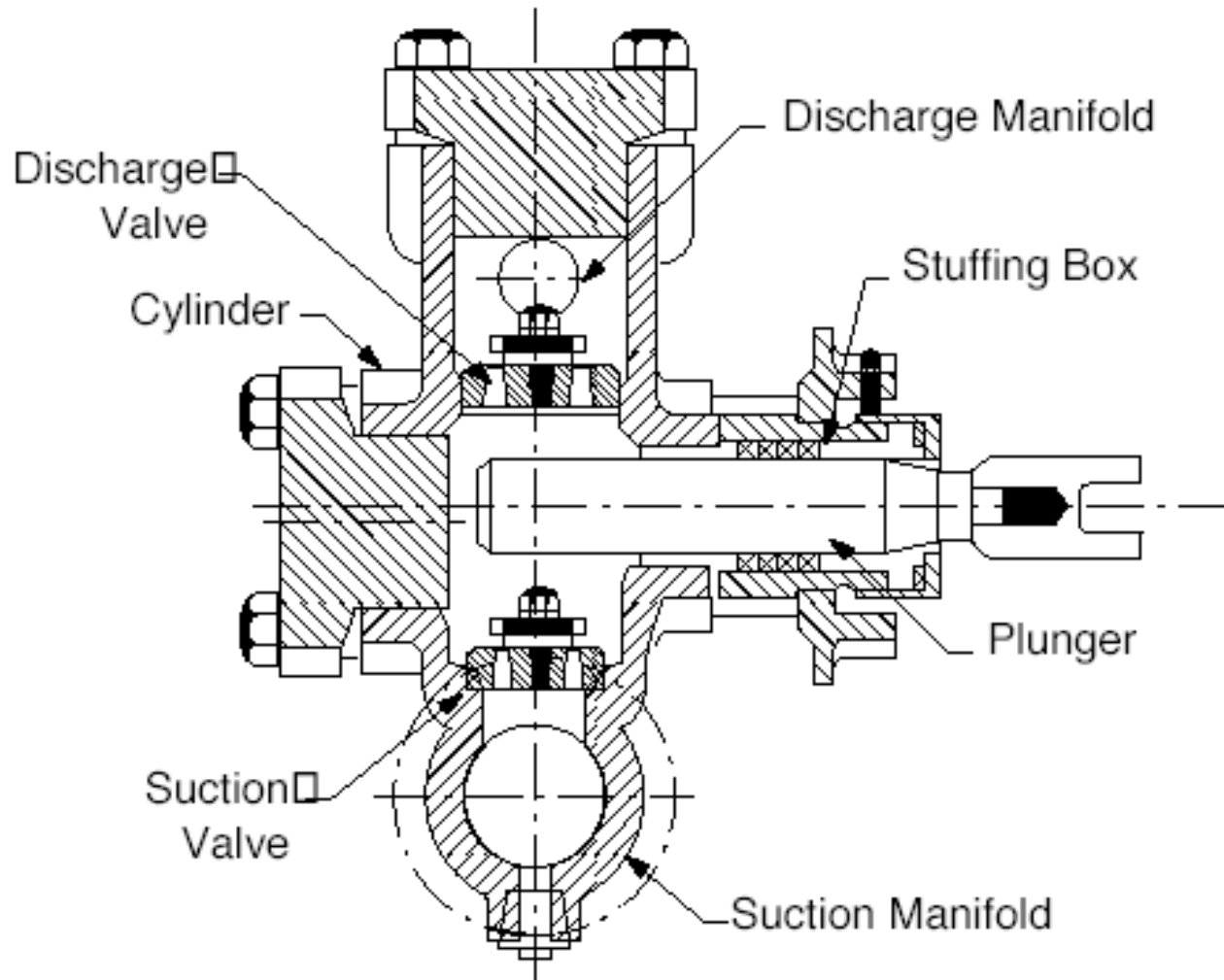

# Piston Pump

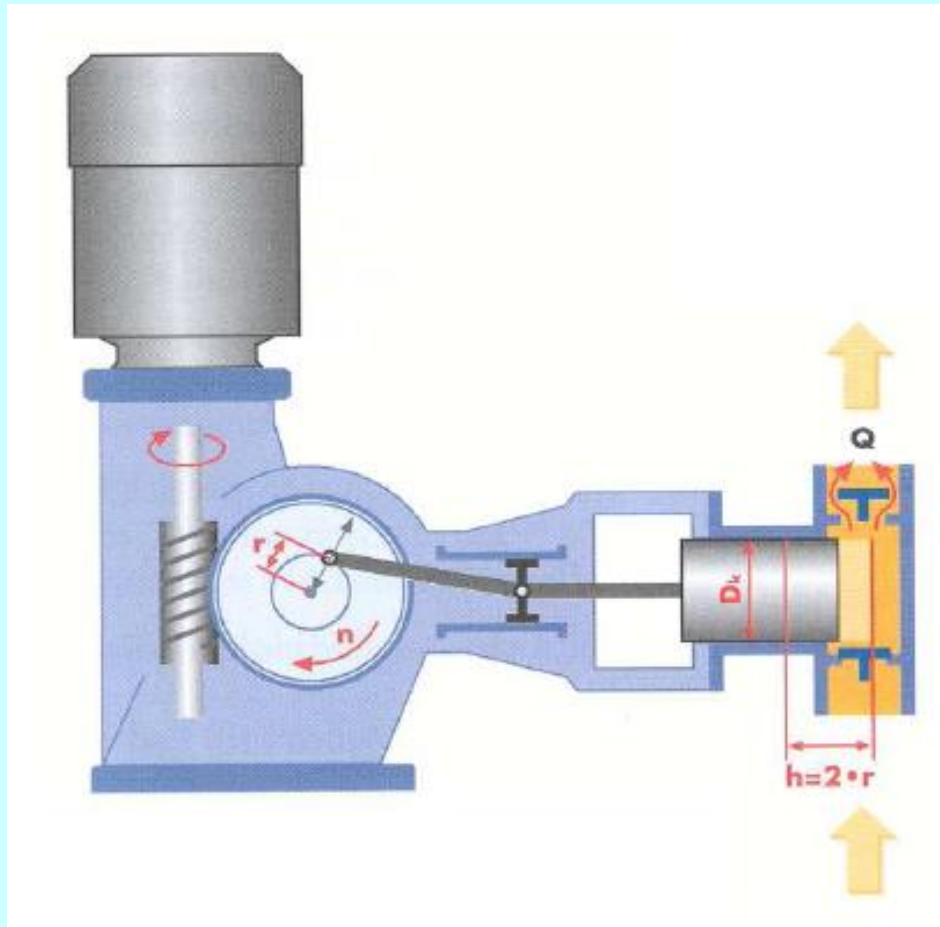

# SHINKO RECIPROCATING STRIPPER PUMP

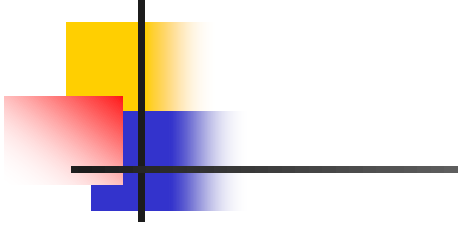
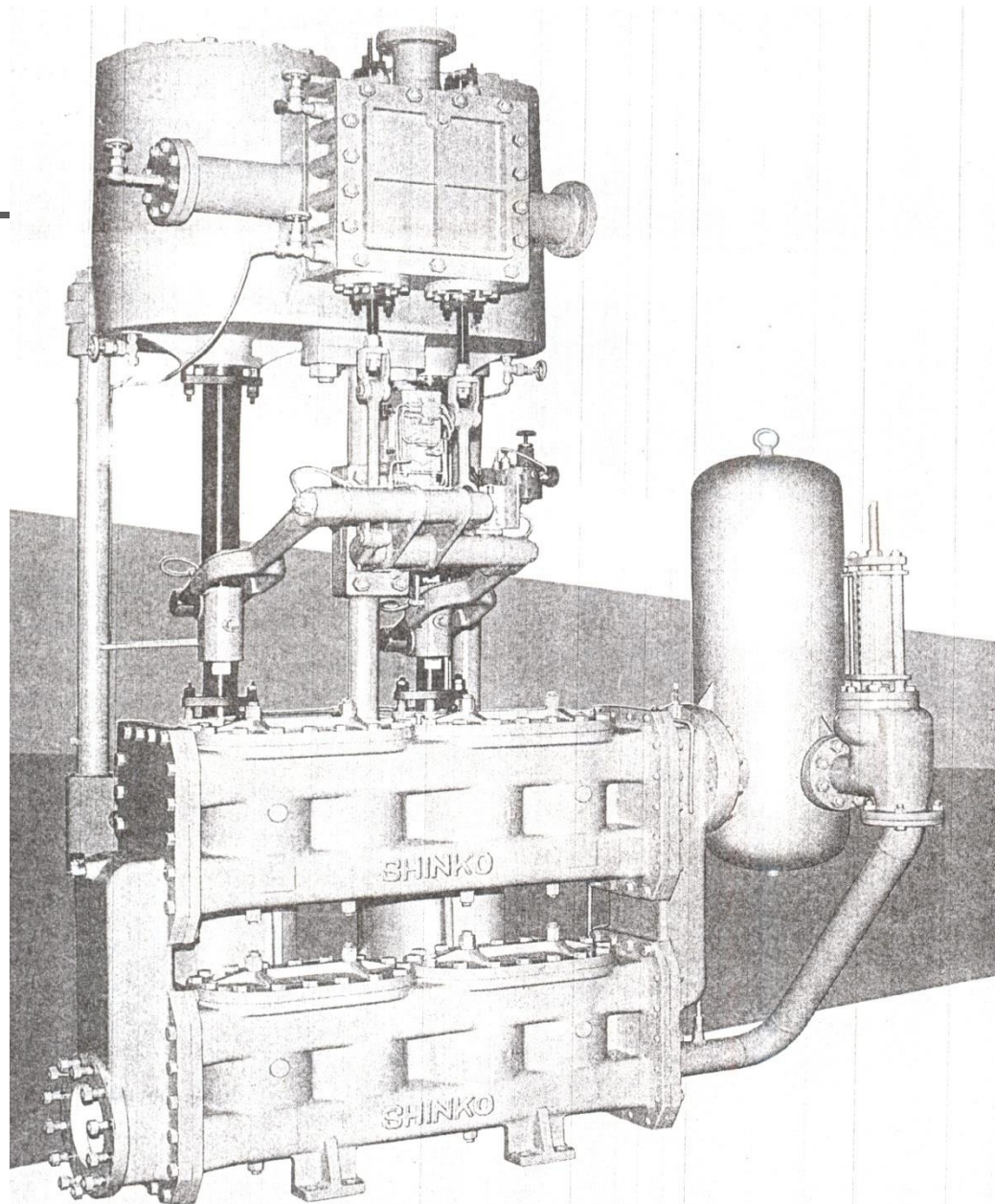

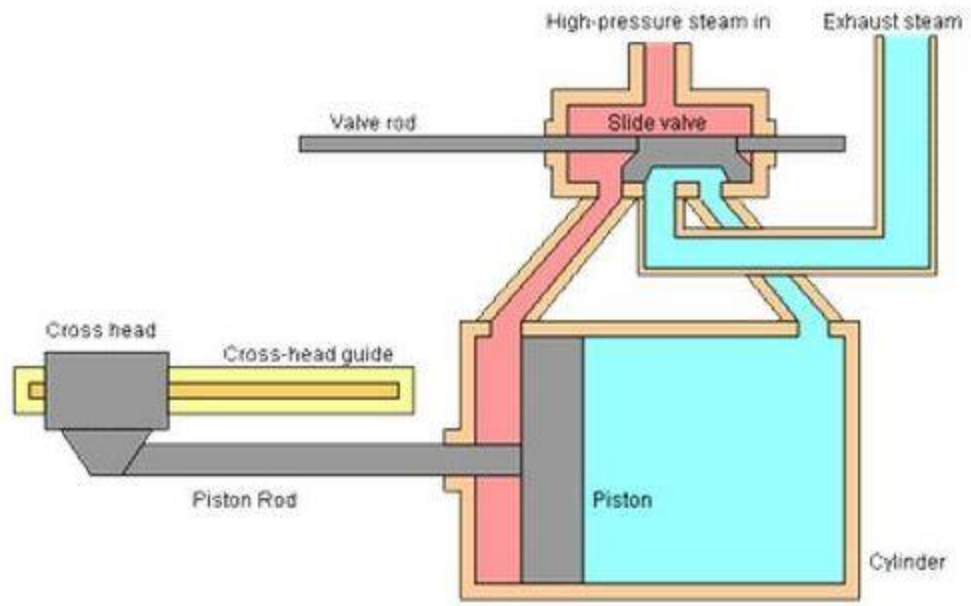
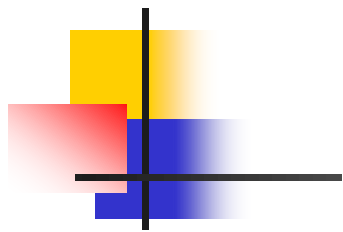

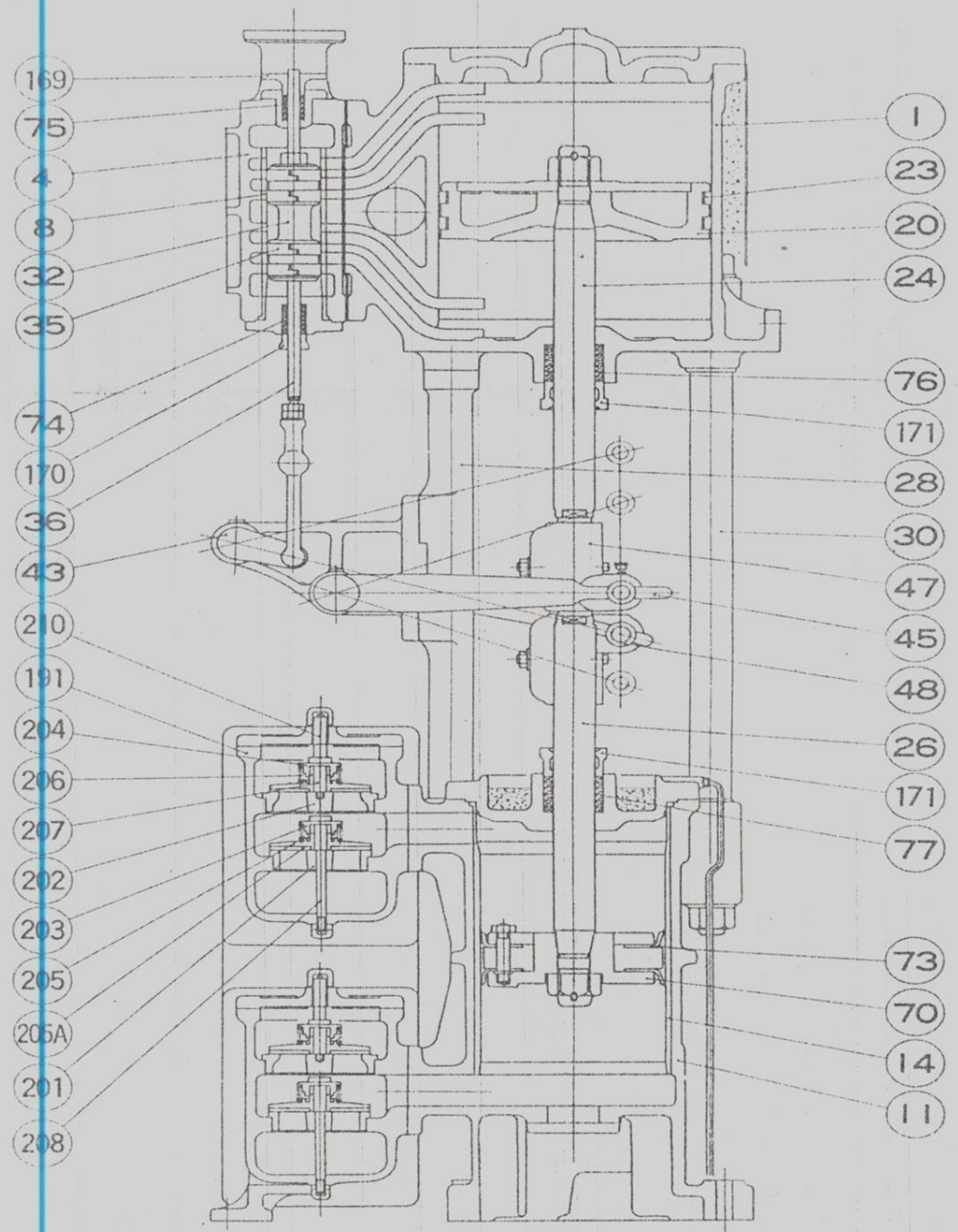
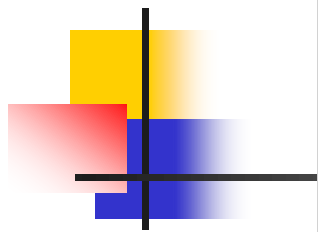



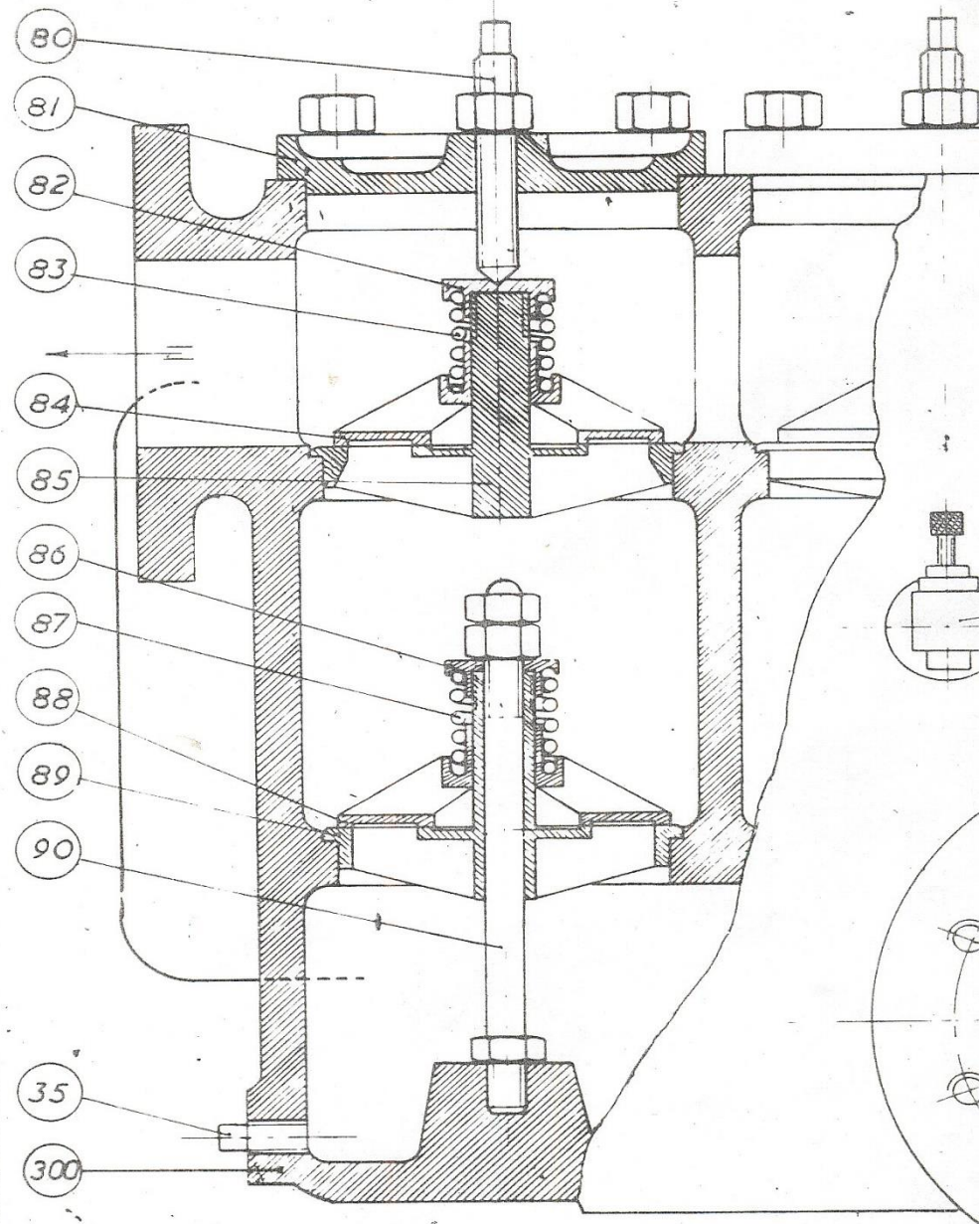

# Various Check V/Vs

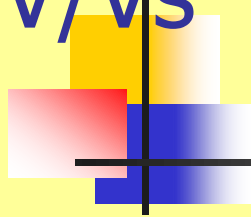

TYPE	SKETCH	PRESSURE	APPLICATION
Plate	<p>A=Seat Area B=Spill Area</p>	5,000	Clean fluid. Plate is metal or plastic.
Wing		10,000	Clean fluids, Chemicals
Ball		30,000	Fluids with particles. Clear, clean fluid at high pressure. Ball is chrome plated.
Plug		6,000	Chemicals
Slurry		2,5000	Mud, slurry. Pot dimensions to API-12. Polyurethane or Buna-N insert

# Axial Piston Pump

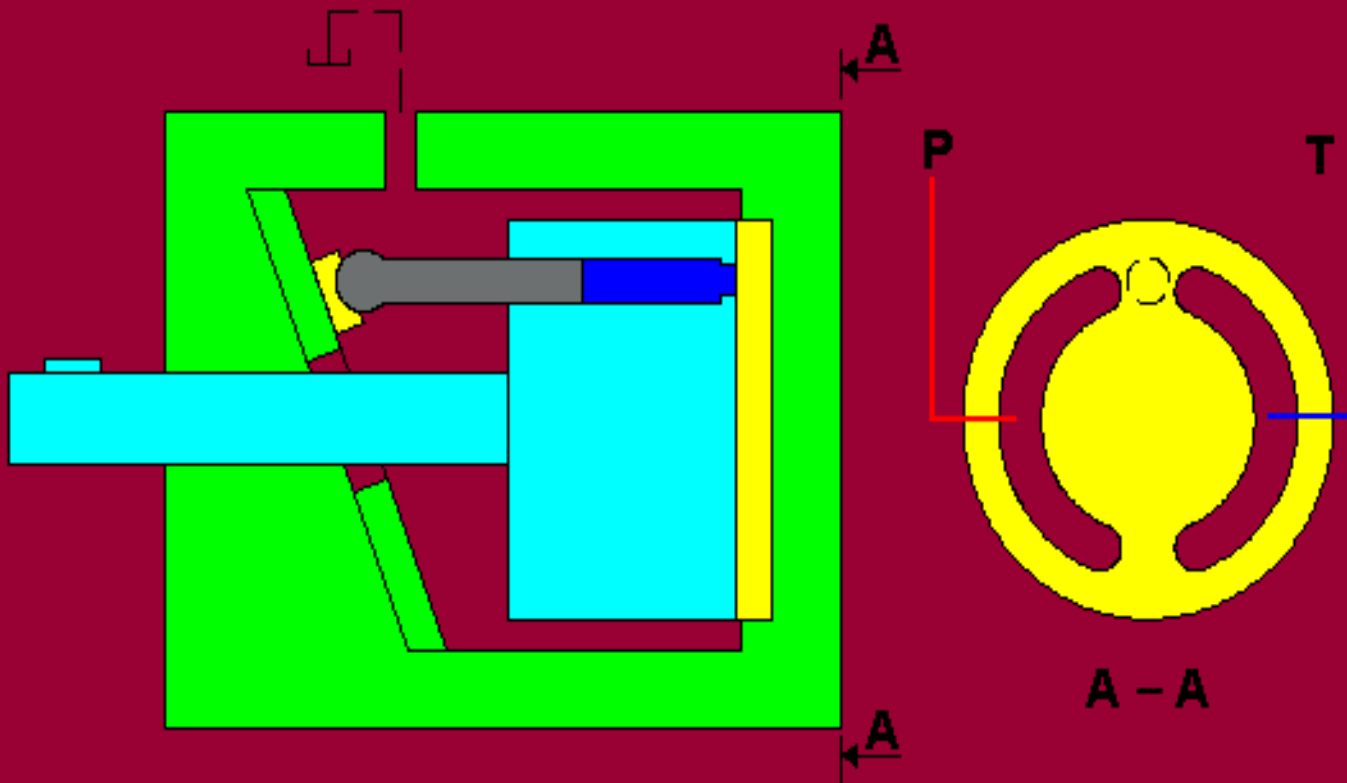
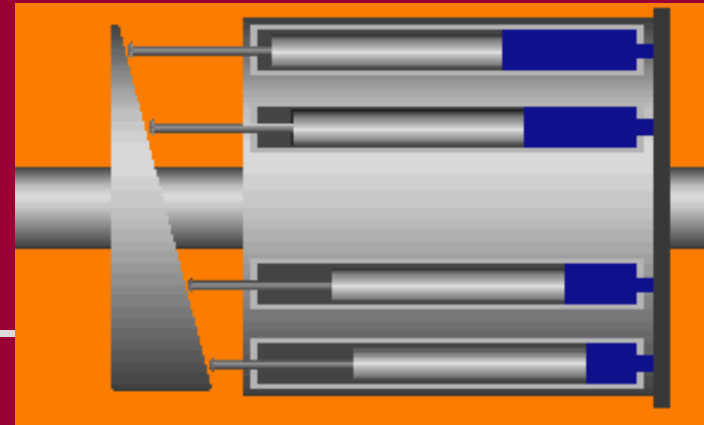

JANNY P/P

64

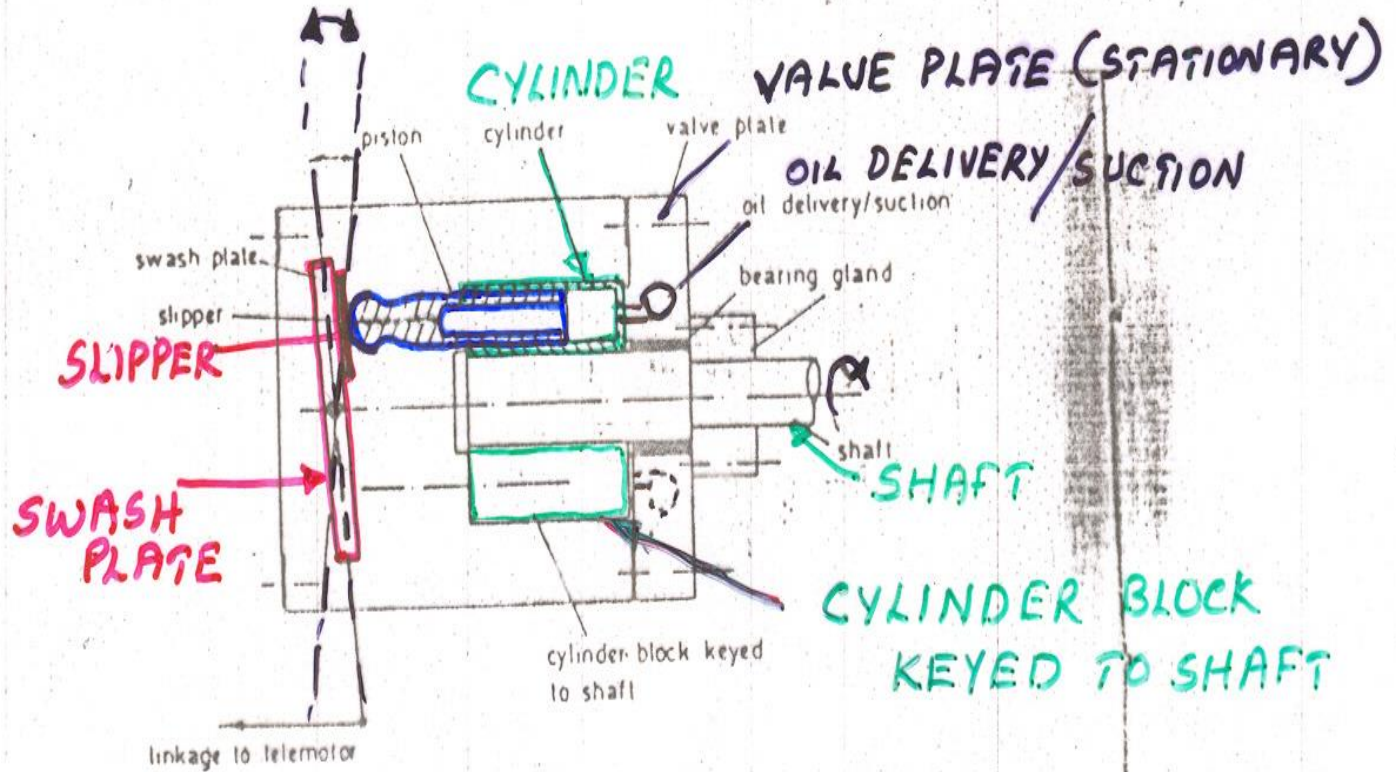

VARIABLE DELIVERY PUMP  
Fig. 5.8

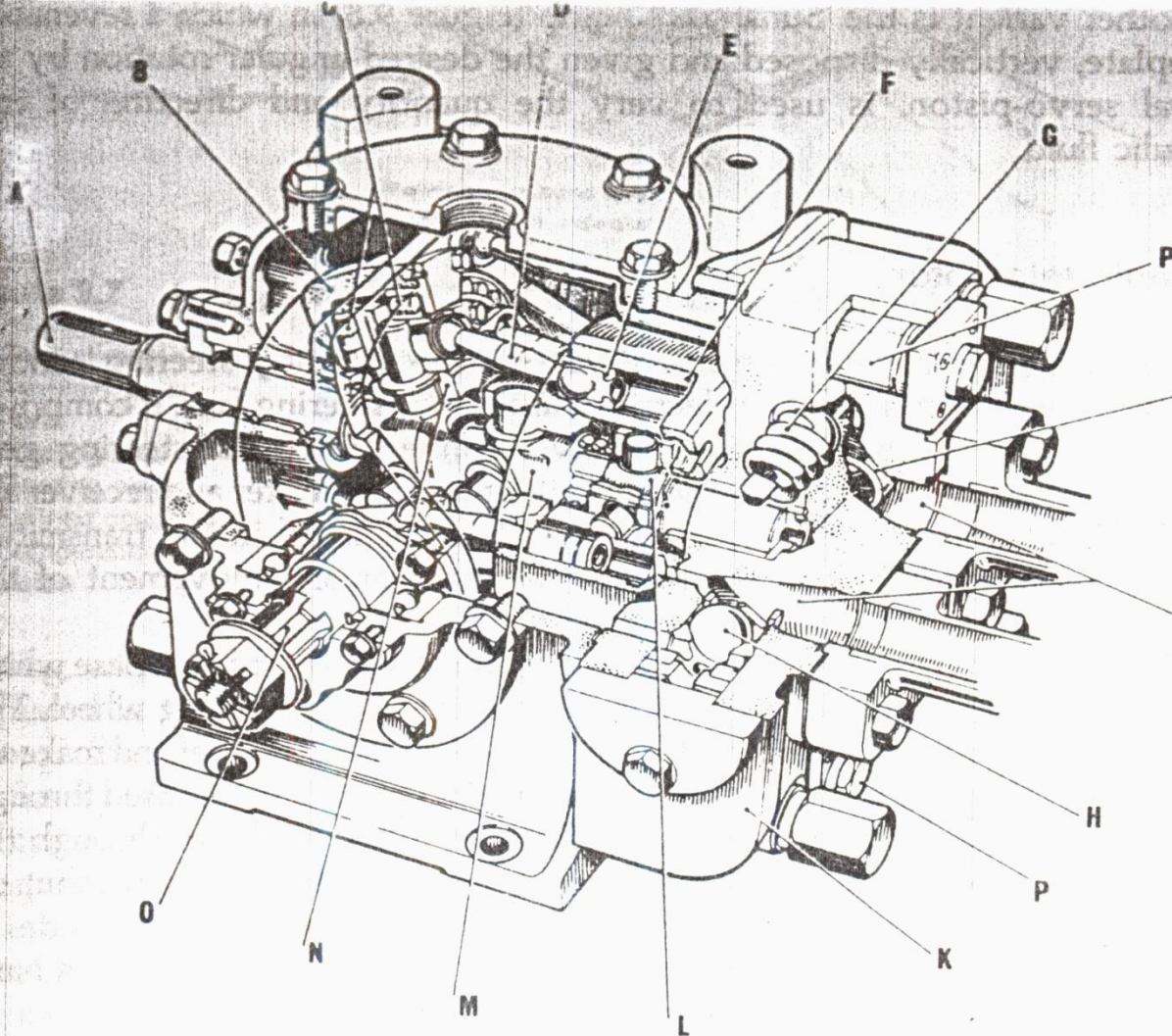

**Figure 9.6** Arrangement of 'VSG' Mark III pump (Vickers Ltd)

A. Input shaft  
 B. Tilting box  
 C. Roller bearings  
 D. Connecting rod  
 E. Piston

F. Cylinder barrel  
 G. Relief valve  
 H. Replenishing valve  
 J. Ports  
 K. Valve plate

L. Barrel joint  
 M. University joint  
 N. Socket ring  
 O. Control trunnion  
 P. Control cylinder

# HELE - SHAW PUMP

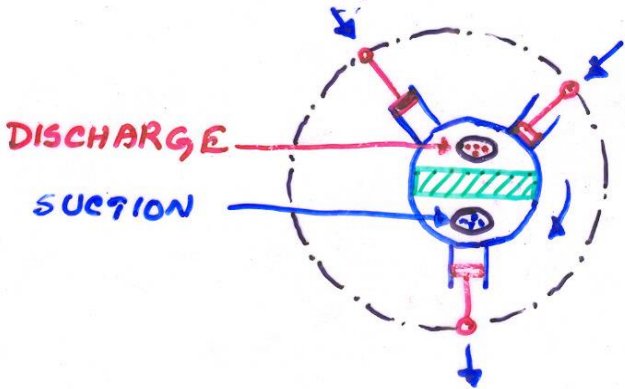
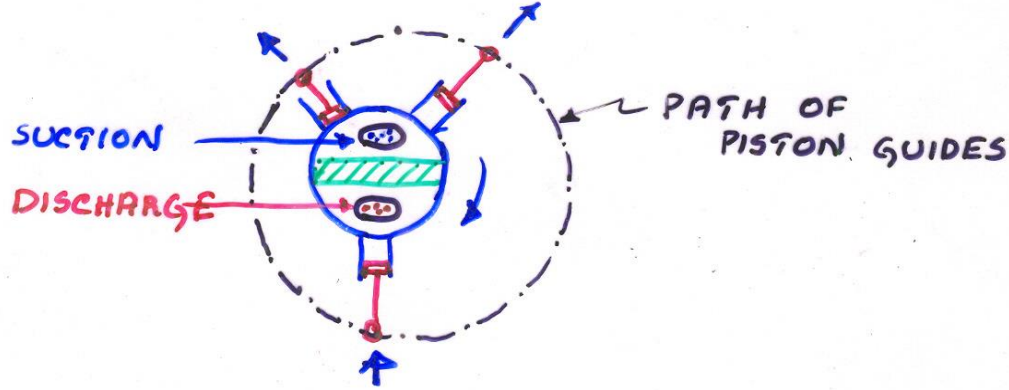
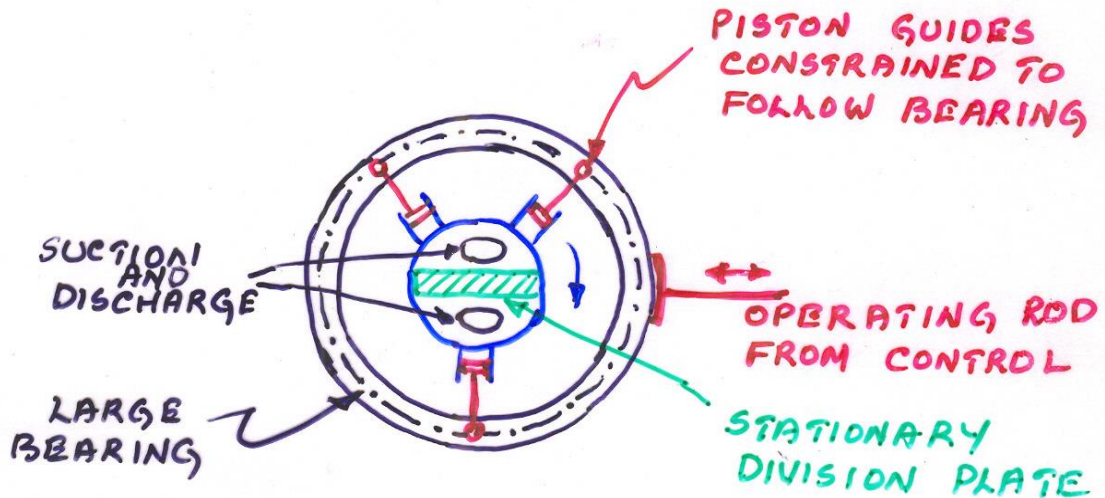

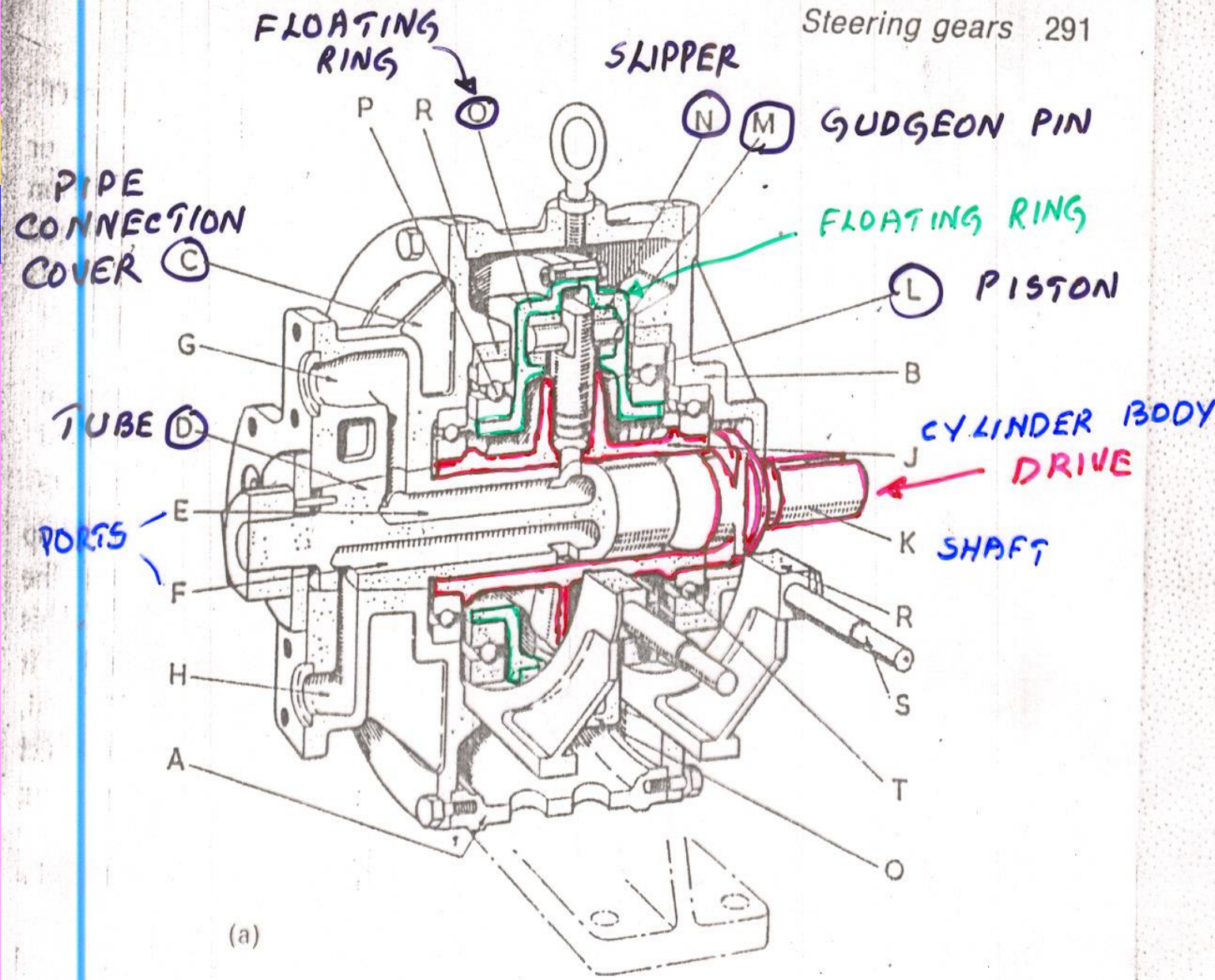

(a)

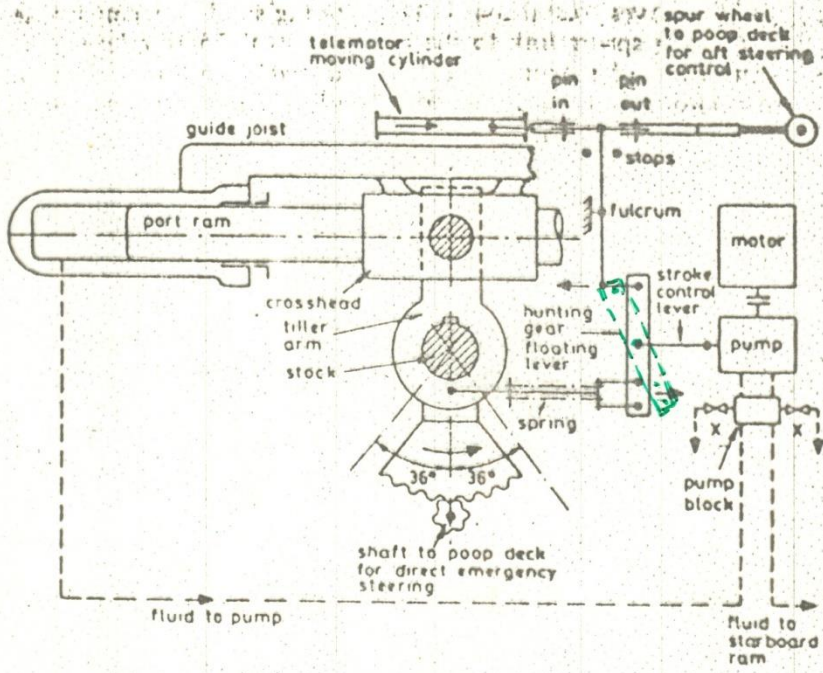

ELECTRO-HYDRAULIC STEERING GEAR  
Fig. 5.9

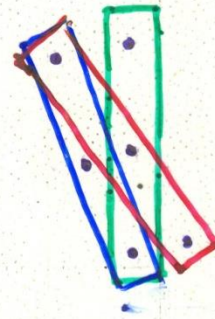



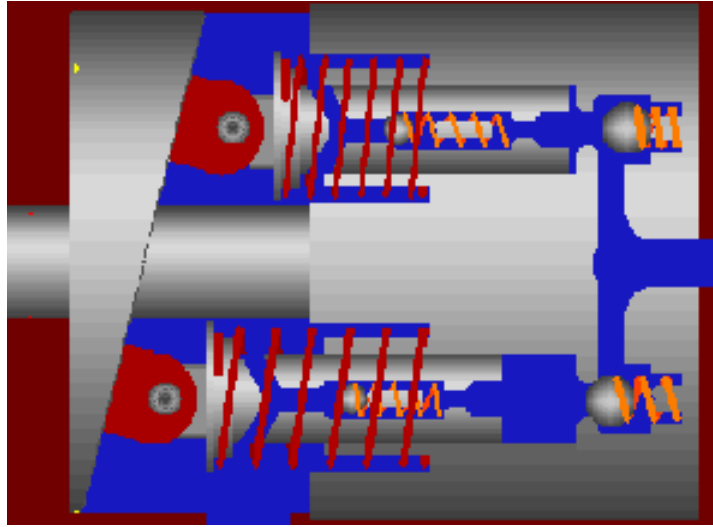
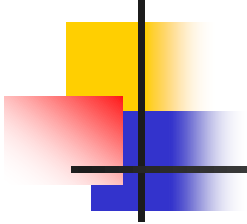

# Swash Plate Pump

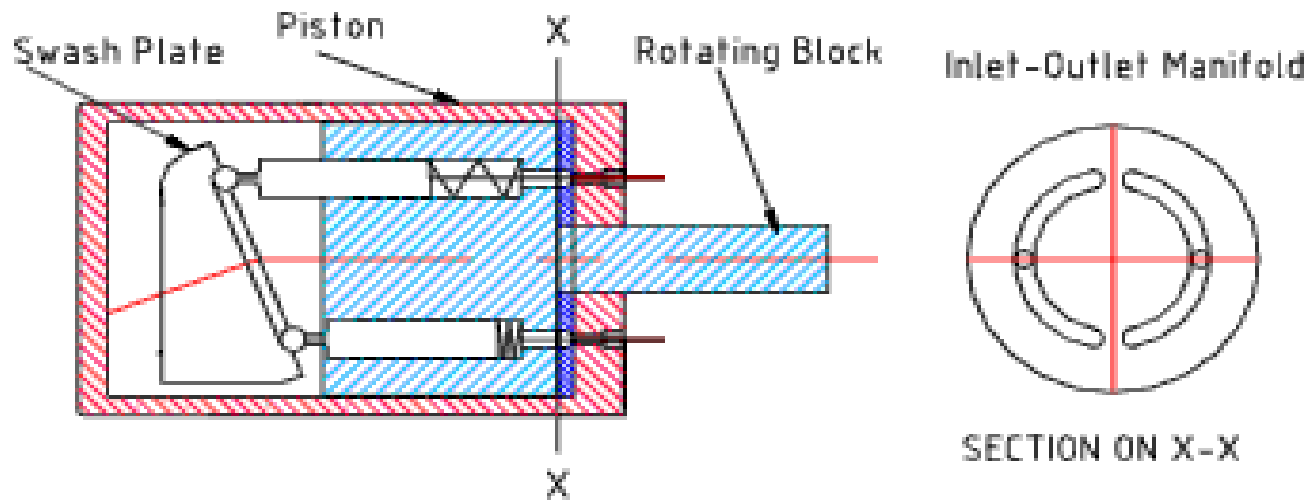

Swashplate Pump

# Axial Piston Pump

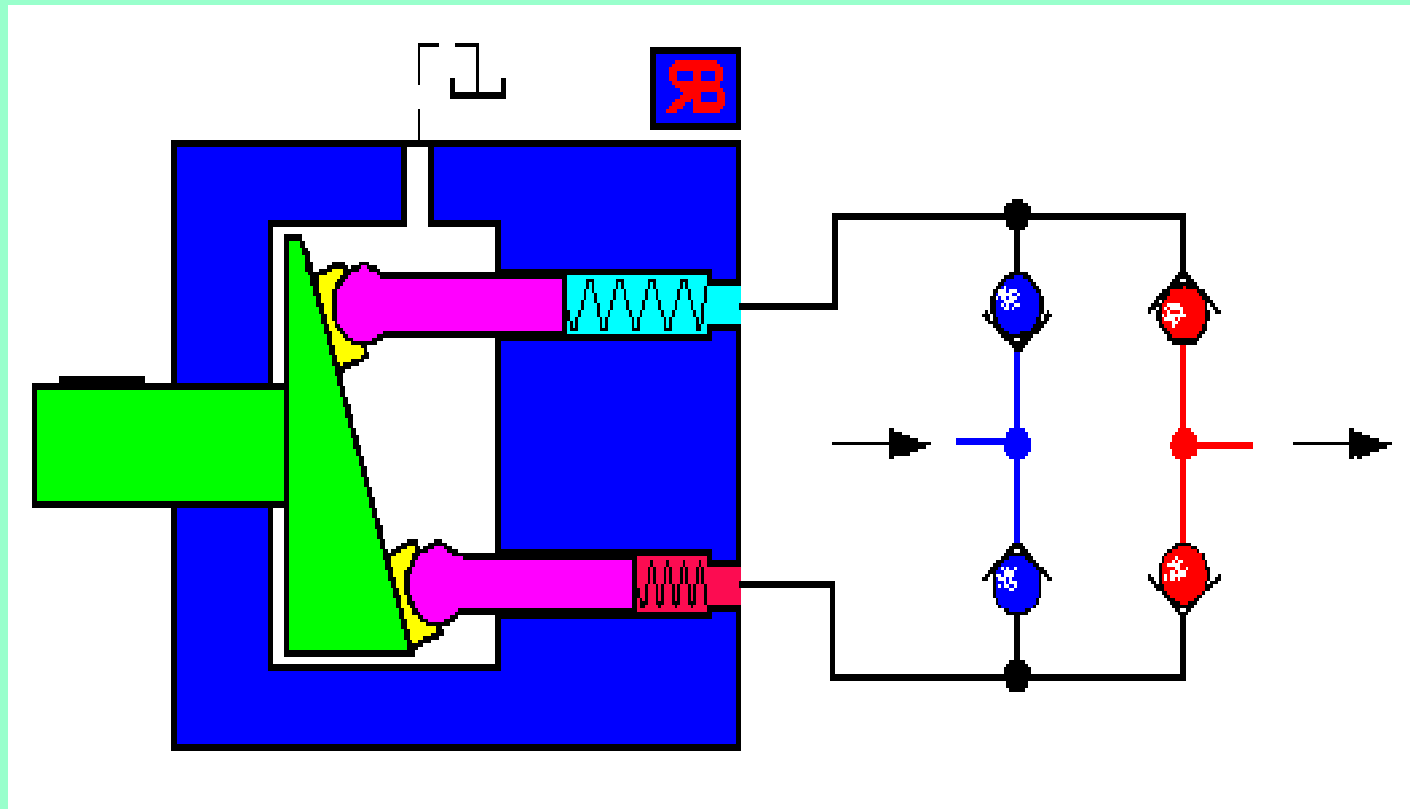

# Radial Piston Pump

---

